



Test report No:  
**NIE: 53453RAN.002**

**Test report**  
**REFERENCE STANDARDS:**  
**FCC 47 CFR Part 2.1093**  
**ISED RSS -102 Issue 5:2015**

Identification of item tested.....:	Bike Navigation Computer
Trademark .....	SIGMA-ELEKTRO GmbH
Model and /or type reference .....	ROX GPS 12.0
Other identification of the product .....	FCC ID: M5LROX-12-0 IC ID: 7580A-ROX120
Final HW version .....	B1
Final SW version .....	Titan_0.17.140_product
Features .....	802.11 b/g/n, Bluetooth, Bluetooth LE and ANT+
Manufacturer .....	SIGMA-ELEKTRO GmbH Dr.-Julius-Leber-Str. 15, 67433 Neustadt a. d. Weinstraße
Test method requested, standard.....:	1. FCC 47 CFR Part 2.1093. (10-1-15 Edition) Radiofrequency radiation exposure evaluation: portable devices. 2. ISED RSS-102 Issue 5 (2015-03) – Radio Frequency Exposure Compliance of Radiocommunication Apparatus (All Frequency Bands)
Summary .....	Considering the results of the performed test according to FCC 47CFR Part 2.1093 and ISED RSS-102 Issue 5, the item under test is <b>IN COMPLIANCE</b> with the requested specifications specified in the standards.  The maximum 1g volume averaged SAR found during this test into the body exposure condition has been 0.638 W/kg, for 802.11b mode.  NOTE: The results presented in this Test Report apply only to the particular item under test established in page 1 of this document, as presented for test on the date(s) shown in section, “USAGE OF SAMPLES, TESTING PERIOD AND ENVIRONMENTAL CONDITIONS”.

Approved by (name / position & signature) .....	Miguel Lacave Antennas Lab Manager	MIGUEL LACAVE GARCÍA 2017.09.18 11:28:42 +02'00'
Date of issue .....	2017-09-18	
Report template No.....	FDT08_20	

# Index

Competences and guarantees.....	4
General conditions.....	4
Uncertainty .....	4
Usage of samples.....	4
Test sample description .....	4
Identification of the client .....	5
Testing period.....	5
Environmental conditions.....	5
Testing verdicts .....	5
Remarks and comments.....	5
Used instrumentation.....	6
Testing verdicts .....	7
Appendix A – Test configuration .....	8
Appendix B – Test results .....	18
Appendix C – Measurement report .....	26
Appendix D – System Validation Reports .....	29
Appendix E – Calibration data .....	31
Appendix F – Photographs .....	83

## Competences and guarantees

DEKRA Testing and Certification S.A.U. is a testing laboratory accredited by the National Accreditation Body (ENAC - Entidad Nacional de Acreditación), to perform the tests indicated in the Certificate No. 51/LE 147

In order to assure the traceability to other national and international laboratories, DEKRA has a calibration and maintenance program for its measurement equipment.

DEKRA guarantees the reliability of the data presented in this report, which is the result of the measurements and the tests performed to the item under test on the date and under the conditions stated on the report and, it is based on the knowledge and technical facilities available at DEKRA at the time of performance of the test.

DEKRA is liable to the client for the maintenance of the confidentiality of all information related to the item under test and the results of the test.

The results presented in this Test Report apply only to the particular item under test established in this document.

**IMPORTANT:** No parts of this report may be reproduced or quoted out of context, in any form or by any means, except in full, without the previous written permission of DEKRA.

## General conditions

1. This report is only referred to the item that has undergone the test.
2. This report does not constitute or imply on its own an approval of the product by the Certification Bodies or competent Authorities.
3. This document is only valid if complete; no partial reproduction can be made without previous written permission of DEKRA.
4. This test report cannot be used partially or in full for publicity and/or promotional purposes without previous written permission of DEKRA and the Accreditation Bodies.

## Uncertainty

Uncertainty (factor  $k=2$ ) was calculated according to the following documents:

1. FCC OET KDB 865664 D01 - SAR Measurement Requirements for 100 MHz to 6 GHz v01r04 (August 2015).

## Usage of samples

Samples undergoing test have been selected by: the client

Sample M/01 is composed of the following elements:

Control N°	Description	Model	Serial N°	Date of reception
54353/01	Bicycle Navigation Computer	ROX GPS 12.0	S/N:12517J00160	2017-06-20

Sample M/02 is composed of the following elements:

Control N°	Description	Model	Serial N°	Date of reception
54353/03	Bicycle Navigation computer	ROX GPS 12.0	S/N:12517J00074	2017-06-20

1. Sample M/01 has undergone the test(s) specified in subclause "Test method requested": Conducted average output power.
2. Sample M/02 has undergone the test(s) specified in subclause "Test method requested": SAR evaluation for 802.11 modes.

## Test sample description

The test sample consists of a bicycle navigation computer.

## Identification of the client

SIGMA-ELEKTRO GmbH

Dr.-Julius-Leber-Str. 15, 67433 Neustadt a. d. Weinstraße

## Testing period

The performed test started on 2017-07-04 and finished on 2017-07-06.

The tests have been performed at DEKRA Testing and Certification, S.A.U.

## Environmental conditions

In the laboratory for measurements, the following limits were not exceeded during the test:

<b>Temperature</b>	Min. = 21.81 °C Max. = 23.88 °C
<b>Relative humidity</b>	Min. = 45.58 % Max. = 63.20 %

## Testing verdicts

The tests documented in this report were performed in accordance with FCC 47 CFR § 2.1093, IC RSS-102 Issue 5 (2015-03) – Radio Frequency Exposure Compliance of Radiocommunication Apparatus (All Frequency Bands) and the following FCC Published RF exposure KDB procedures:

1. FCC OET KDB 447498 D01 General RF Exposure Guidance v06 (October 2015)
2. FCC OET KDB 865664 D01 SAR Measurement Requirements for 100 MHz to 6 GHz v01r04 (August 2015).
3. FCC OET KDB 865664 D02 RF Exposure Reporting v01r02 (October 2015)
4. FCC OET KDB 248227 D01 802.11 Wi-Fi SAR v02r02 (October 2015).

## Remarks and comments

1: Zoom scan is not required according to FCC OET KDB 447498 D01 General RF Exposure Guidance v06, paragraph “4.4.2. Area scan based 1-g estimation”

2: Only the plots of the highest reported SAR for each test position and mode/band are included in appendix C.

## Used instrumentation

1. Dosimetric E-field probe SPEAG EX3DV4
2. Data acquisition device SPEAG DAE4
3. Electro-optical converter SPEAG EOC3
4. 2450 MHz dipole validation kit SPEAG D2450V2
5. Robot Stäubli RX60BL
6. Robot controller Stäubli CM7MB
7. SAR measurement software SPEAG DASY52 V52.8.8.1222
8. SAR post processing software SPEAG SEMCAD X
9. Measurement server SPEAG DASY5 SE UMS 011 BS
10. Oval flat phantom SPEAG ELI 4
11. Head Tissue Equivalent Liquids for 2450MHz band
12. Vector network analyzer Agilent FieldFox N9923A
13. Dielectric probe kit SPEAG DAK-3.5
14. Power sensor DC 50 MHz to 18 GHz R&S model NRP-Z81
15. Power meter Agilent E4419B
16. RF Generator R&S SMU200A
17. DC Power supply Agilent U8002A
18. Dual directional coupler NARDA FSCM 99899
19. Power amplifier MITEQ AMF-4D-00400600-50-30P
20. 6 dB attenuator Weinschel 75 A-6-11
21. 20 dB attenuator Weinschel 75 A-20-11
22. SPEAG Mounting Device for Hand-Held Transmitters.
23. Digital thermometer LKM Electronics model DTM300-Spezial
24. Temperature and humidity probe HUMIDIROBE Pico Technology.
25. Anritsu MT8852A Bluetooth testing unit.

## Testing verdicts

<b>Not applicable</b> .....	:	N/A
<b>Pass</b> .....	:	P
<b>Fail</b> .....	:	F
<b>Not measured</b> .....	:	N/M

### - 2450 MHz Band

FCC 47CFR Part 2.1093 & ISED RSS-102 Issue 5	VERDICT			
	NA	P	F	NM
802.11 b/g/n20/n40	P			
Bluetooth	P			
ANT+	P			

# Appendix A – Test configuration



## INDEX

1.	GENERAL INTRODUCTION .....	10
1.1.	Application Standard.....	10
1.2.	General requirements .....	10
1.3.	Measurement system requirements .....	10
1.4.	Phantom requirements.....	10
1.5.	Measurement Liquids requirements.....	10
2.	MEASUREMENT SYSTEM.....	11
2.1.	Measurement System .....	11
2.2.	Test Positions of device relative to body .....	14
2.3.	Test to be performed .....	15
2.4.	Description of interpolation/extrapolation scheme .....	15
2.5.	Determination of the largest peak spatial-average SAR .....	15
2.6.	System Validation .....	15
3.	UNCERTAINTY .....	16
4.	SAR LIMIT .....	17
5.	DEVICE UNDER TEST .....	17
5.1.	Dimensions.....	17
5.2.	Wireless Technology.....	17
5.3.	Simultaneous Transmission.....	17
5.4.	DUT Antenna Location.....	17

## 1. GENERAL INTRODUCTION

### 1.1. Application Standard

The Federal Communications Commission (FCC) sets the limits for General Population/Uncontrolled exposure to radio frequency electromagnetic fields for transmitting devices designed to be used within 20 centimetres of the body of the user under FCC 47 CFR Part 2.1093 - “Radiofrequency radiation exposure evaluation: portable devices”, paragraph (d)(2).

Industry of Canada (ISED) sets the limits for General Population/Uncontrolled environment when the exposure occurs at a distance of 0.2 m or less into the RSS-102 Issue 5, paragraph 4 “Exposure Limits”, Table 3.

### 1.2. General requirements

The SAR measurement has been performed continuing the following considerations and environment conditions:

- The ambient temperature shall be in the range of 18°C to 25°C and the variation shall not exceed +/- 2°C during the test.
- The ambient humidity shall be in the range of and 30% - 70%.
- The device battery shall be fully charged before each measurement.

### 1.3. Measurement system requirements

The measurement system used for SAR tests fulfils the procedural and technical requirements described at the reference standards used.

### 1.4. Phantom requirements

The phantom model for body measurements is an elliptical open-top container with a flat bottom, with the following shape and dimensions:

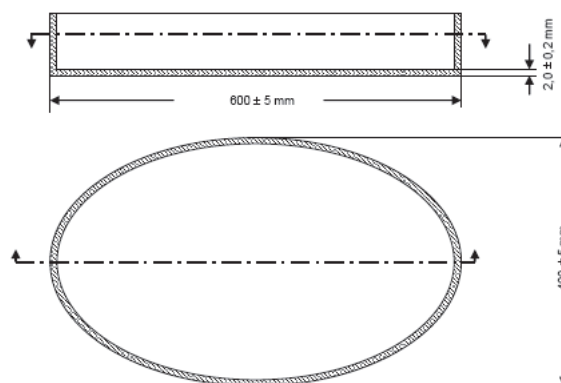

Figure 1: Proportions and shape of Phantom shell

### 1.5. Measurement Liquids requirements.

The liquids used to simulate the human tissues, must fulfil the requirements of the dielectric properties required. These target dielectric properties per FCC OET KDB 865664 D01 instructions come from the dipole and probe calibration data which are included in Appendix B, Section 3, of this document.

To minimize the effect of reflections on peak spatial-average SAR values, from the upper surface of the tissue-equivalent liquid, the depth of the liquid should be at least 15 cm.

## 2. MEASUREMENT SYSTEM

### 2.1. Measurement System

The DASY5 system for performing compliance tests consists of the following items:

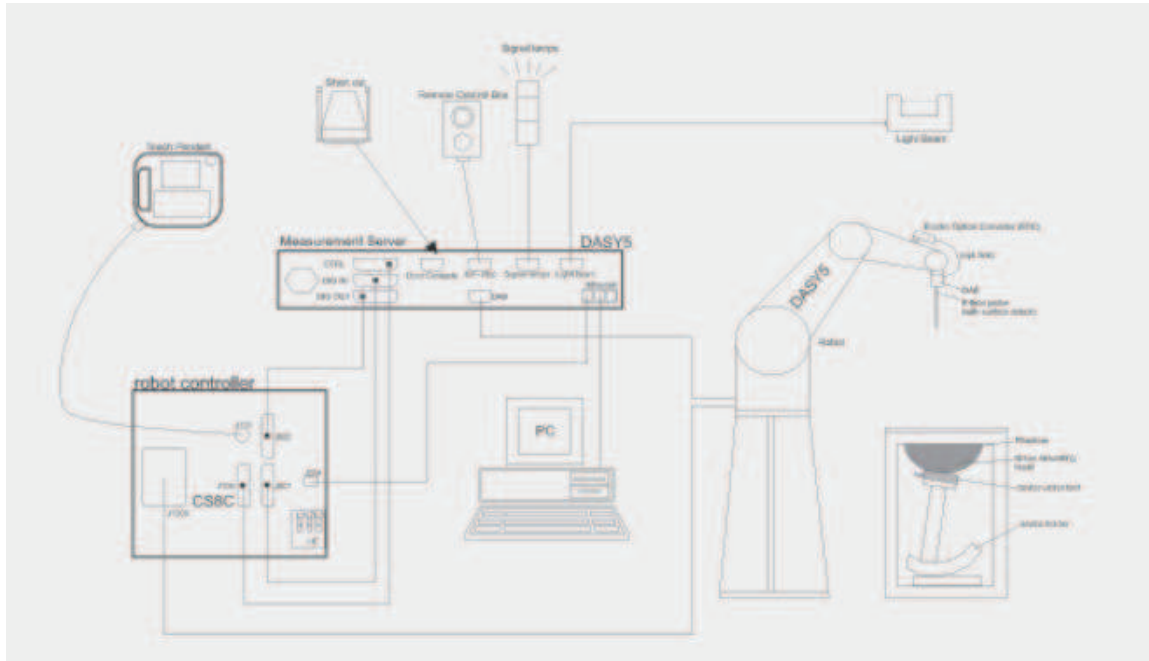



**Figure 2:** SAR Measurement system

- A standard high precision 6-axis robot (Stäubli TX=RX family) with controller, teach pendant and software. An arm extension for accommodating the data acquisition electronics (DAE).
- An isotropic field probe optimized and calibrated for the targeted measurement.
- A data acquisition electronics (DAE) which performs the signal amplification, signal multiplexing, AD-conversion, offset measurements, mechanical surface detection, collision detection, etc. The unit is battery powered with standard or rechargeable batteries. The signal is optically transmitted to the EOC.
- The Electro-optical converter (EOC) performs the conversion from optical to electrical signals for the digital communication to the DAE. To use optical surface detection, a special version of the EOC is required. The EOC signal is transmitted to the measurement server.
- The function of the measurement server is to perform the time critical tasks such as signal filtering, control of the robot operation and fast movement interrupts.
- The Light Beam used is for probe alignment. This improves the (absolute) accuracy of the probe positioning.
- A computer running Win7 professional operating system and the DASY5 software.
- Remote control and teach pendant as well as additional circuitry for robot safety such as warning lamps, etc.
- The phantom, the device holder and other accessories according to the targeted measurement.

Manufacturer	Device	Type
Schmid & Partner Engineering AG	Dosimetric E-Field Probe	EX3DV4
Schmid & Partner Engineering AG	Data Acquisition Electronics	DAE4
Schmid & Partner Engineering AG	Electro-Optical Converter	EOC3
Stäubli	Robot	RX60BL
Stäubli	Robot controller	CS7MB
Schmid & Partner Engineering AG	Measurement Server	DASY5 SE UMS 011 BS
Schmid & Partner Engineering AG	Oval flat phantom	SPEAG ELI 4
Schmid & Partner Engineering AG	Mounting Device for Laptops/body-worn	SM LH1 001 AC
Schmid & Partner Engineering AG	Measurement Software	DASY52 V52.8.8.1222
Schmid & Partner Engineering AG	Postprocessing Software	SEMCAD X
Schmid & Partner Engineering AG	2450 MHz System Validation Dipole	D2450V2
Agilent	Vector Network Analyser	FieldFox N9923A
Schmid & Partner Engineering AG	Dielectric Probe Kit	DAK-3.5

**Table 1:** Measurement Equipment

	<b>Model</b>	<b>EX3DV4</b>
	<b>Construction</b>	Symmetrical design with triangular core. Built-in shielding against static charges. PEEK enclosure material (resistant to organic solvents, e.g., DGBE).
	<b>Frequency</b>	10 MHz to > 6 GHz; Linearity: $\pm 0.2$ dB (30 MHz to 6 GHz)
	<b>Directivity</b>	$\pm 0.3$ dB in TSL (rotation around probe axis) $\pm 0.5$ dB in TSL (rotation normal to probe axis)
	<b>Dynamic Range</b>	10 $\mu$ W/g to > 100 mW/g Linearity: $\pm 0.2$ dB (noise: typically < 1 $\mu$ W/g)
	<b>Dimensions</b>	Overall length: 337 mm (Tip: 20 mm) Tip diameter: 2.5 mm (Body: 12 mm) Typical distance from probe tip to dipole centers: 1.0 mm

	<b>Model</b>	<b>DAE4</b>
	<b>Construction</b>	Signal amplifier, multiplexer, A/D converter, and control logic. Serial optical link communication with DASY4/5 embedded system (fully remote controlled). Two-step probe touch detector for mechanical surface detection and emergency robot stop.
	<b>Measurement Range</b>	-100 to +300 mV (16 bit resolution and two range settings: 4mV, 400mV)
	<b>Input Offset Voltage</b>	< 5 $\mu$ V (with auto zero)
	<b>Input Resistance</b>	200 MOhm
	<b>Input Bias Current</b>	< 50 fA

	<b>Model</b>	<b>ELI</b>
	<b>Construction</b>	Phantom for compliance testing of handheld and body-mounted wireless devices in the frequency range of 30 MHz to 6 GHz. ELI is fully compatible with the IEC 62209-2 standard and all known tissue simulating liquids. ELI has been optimized regarding its performance and can be integrated into our standard phantom tables. A cover prevents evaporation of the liquid. Reference markings on the phantom allow installation of the complete setup, including all predefined phantom positions and measurement grids, by teaching three points. The phantom is compatible with all SPEAG dosimetric probes and dipoles.
	<b>Material</b>	Vinylester, glass fiber reinforced (VE-GF)
	<b>Liquid Compatibility</b>	Compatible with all SPEAG tissue simulating liquids (incl. DGBE type)
	<b>Shell Thickness</b>	2 $\pm$ 0.2 mm (bottom plate)
	<b>Dimensions</b>	Major axis: 600 mm Minor axis: 400 mm
	<b>Filling Volume</b>	Approx. 30 liters
	<b>Wooden Support</b>	SPEAG standard phantom table

	<b>Model</b>	<b>Mounting Device for Hand-Held Transmitters</b>
	<b>Construction</b>	In combination with the Twin SAM V5.0/V5.0c or ELI Phantoms, the Mounting Device for Hand-Held Transmitters enables rotation of the mounted transmitter device to specified spherical coordinates. At the heads, the rotation axis is at the ear opening. Transmitter devices can be easily and accurately positioned according to IEC 62209-1, IEEE 1528, FCC, or other specifications. The device holder can be locked for positioning at different phantom sections (left head, right head, flat).
	<b>Material</b>	Polyoxymethylene (POM)

	<b>Model</b>	<b>System Validations Kits 450 MHz – 6 GHz</b>			
	<b>Construction</b>	Symmetrical dipole with I/4 balun. Enables measurement of feedpoint impedance with NWA. Matched for use near flat phantoms filled with tissue simulating solutions.			
	<b>Frequency</b>	450 MHz to 5800 MHz			
	<b>Return Loss</b>	20 dB at specified validation position			
	<b>Dimensions (length and overall height in mm)</b>	<b>Product</b>	<b>Dipole length</b>	<b>Overall height</b>	
		D450V3	290.0	330.0	
D750V3		179.0	330.0		
D900V2		148.5	340.0		
D1800V2		72.5	300.0		
D2000V2		65.0	300.0		
D2450V2		52.0	290.0		
D2600V2	49.2	290.0			
D5GHzV2	20.6	300.0			

## 2.2. Test Positions of device relative to body

The device under test is a bicycle computer that will be normally used installed into the bicycle's handlebar. As the device can be dismounted of the bicycle's handlebar, it also would be able to transmit while mounted on a person's body while being carried it into a pocket. According to 447498 D01 General RF Exposure Guidance v06, as the device can operate on the body of users without requiring additional body-worn accessories, SAR compliance has been tested using a conservative minimum test separation distance of 5 mm.

The device has been tested in the following test positions to be in compliance with this possible body-worn device operation:

- *Back Face*: back side of the device against the flat phantom surface.
- *Front Face*: front side of the device against the flat phantom surface.

### 2.3. Test to be performed

DUT will be placed at the center of flat phantom. The DUT position used during the body SAR tests will be the one where the maximum peak SAR was found. Each data mode, wireless technology and frequency band supported by the device must be tested. Low and high channels for each band should be tested at this position.

If the DUT is also designed to transmit with other configurations (antenna fully extended/retracted, keypad cover opened/closed...), all tests described above shall be performed for each configuration. When considering multi-mode and multi-band mobile phones, all of the tests shall be performed at each transmitting mode/band with the corresponding maximum peak power level.

### 2.4. Description of interpolation/extrapolation scheme

The local SAR inside the Phantom is measured using small dipole sensing elements inside a probe element. The probe tip must not be in contact with the Phantom's surface in order to minimize measurement errors, but the highest local SAR is obtained from measurements at a certain distance from the shell through extrapolation. The accurate assessment of the maximum SAR averaged over 1 gr and 10 gr. requires a very fine resolution in the three-dimensional scanned data array. Since the measurements have to be performed over a limited time, the measured data have to be interpolated to provide an array of sufficient resolution.

The interpolation of 2D area scan is used after the initial area scan, at a fixed distance from the Phantom shell wall. The initial scan data is collected with approx. 15 mm spatial resolution and this interpolation is used to find the location of the local maximum for positioning the subsequent 3D scanning within a 1 mm resolution.

For the 3D scan, data is collected on a spatially regular 3D grid having 5 mm steps in both directions. After the data collection by the SAR probe, the data are extrapolated in the depth direction to assign values to points in the 3D array closer to the shell wall. A notional extrapolation value is also assigned to the first point outside the shell wall so that subsequent interpolation schemes will be applicable right up to the shell wall boundary.

### 2.5. Determination of the largest peak spatial-average SAR

To determine the maximum value of the peak spatial-average SAR of a DUT, all device positions, configurations and operational modes should be tested for each frequency band.

The averaging volume shall be chosen as 1 gr. of contiguous tissue. The cubic volumes, over which the SAR measurements are averaged after extrapolation and interpolation, are chosen in order to include the highest values of local SAR.

The maximum SAR level for the DUT will be the maximum level obtained of the performed measurements, and indicated in the previous points.

### 2.6. System Validation

Prior to the SAR measurements, system verification is done to verify the system accuracy. A complete SAR evaluation is done using a half-wavelength dipole as source with the frequency of the mid-band channel of the operating band, or within 10% of this channel.

The measured 1 gr. and 10 gr. SAR should be within 10% of the expected target values specified in the calibration certificate of the dipole, for the specific tissue and frequency used.

### 3. UNCERTAINTY

According to FCC OET KDB 865664 D01 - SAR Measurement Requirements for 100 MHz to 6 GHz v01r04 (August 2015), as the highest measured 1-g SAR has been < 1.5 W/kg, SAR measurement uncertainty analysis described in IEEE Std 1528-2013 is not required in the actual SAR report, but it has been included for ISO 17025 accreditation.

#### Uncertainty for 300 MHz – 6 GHz

ERROR SOURCES	Uncertainty value (± %)	Probability distribution	Divisor	(c) 1g	(c) 10g	Standard uncertainty (1g) (± %)	Standard uncertainty (10g) (± %)
<b>Measurement Equipment</b>							
Probe Calibration	6.550	N	1	1	1	6.550	6.550
Axial Isotropy	4.700	R	√3	0.7	0.7	1.899	1.899
Hemispherical Isotropy	9.600	R	√3	0.7	0.7	3.880	3.880
Boundary effect	2.000	R	√3	1	1	1.155	1.155
Linearity	4.700	R	√3	1	1	2.714	2.714
System Detection limits	1.000	R	√3	1	1	0.577	0.577
Probe modulation response	6.100	R	√3	1	1	3.522	3.522
Readout electronics	0.300	N	1	1	1	0.300	0.300
Response time	0.800	R	√3	1	1	0.462	0.462
Integration time	2.600	R	√3	1	1	1.501	1.501
RF Ambient noise	3.000	R	√3	1	1	1.732	1.732
RF Ambient reflections	3.000	R	√3	1	1	1.732	1.732
Probe positioner mech. restrictions	0.800	R	√3	1	1	0.462	0.462
Probe positioning with respect to phantom shell	6.700	R	√3	1	1	3.868	3.868
Max. SAR Eval.	4.000	R	√3	1	1	2.309	2.309
<b>Test Sample Related</b>							
Device holder uncertainty	2.900	N	1	1	1	2.900	2.900
Test sample positioning	3.600	N	1	1	1	3.600	3.600
Drift of output power	5.000	R	√3	1	1	2.887	2.887
<b>Phantom and Setup</b>							
Phantom uncertainty (shape and thickness tolerances)	6.600	R	√3	1	1	3.811	3.811
Algorithm for correcting SAR for deviations in permittivity and conductivity	1.900	R	√3	1	0.84	1.097	0.921
Liquid conductivity (meas.)	2.454	N	1	0.78	0.71	1.914	1.742
Liquid permittivity (meas.)	2.454	N	1	0.26	0.26	0.638	0.638
Liquid conductivity – temperature uncertainty	3.400	R	√3	0.78	0.71	1.531	1.394
Liquid permittivity – temperature uncertainty	0.400	R	√3	0.23	0.26	0.053	0.060
<b>Combined standard uncertainty</b>	$u_c = \sqrt{\sum_{i=1}^m c_i^2 \cdot u_i^2}$					<b>12.82</b>	<b>12.76</b>
<b>Expanded uncertainty (confidence interval of 95%)</b>	$ue = 2.00 u_c$					<b>25.64</b>	<b>25.53</b>

**Table 2:** Uncertainty Assessment for 300 MHz - 6 GHz



#### 4. SAR LIMIT

Having a worst case measurement, the SAR limit is valid for general population/uncontrolled exposure.

The SAR values have to be averaged over a mass of 1 gr. (SAR 1 gr.) with the shape of a cube and averaged over a mass of 10 gr (Extremity SAR 10 gr). These levels couldn't exceed the values indicated in the application Standard:

Standard	Exposure	SAR	SAR Limit (W/kg)
FCC 47 CFR Part 2.1093, Paragraph (d)(2) RSS-102 Issue 5 (2015-03), Paragraph 4	General population/Uncontrolled	SAR <sub>1 gr.</sub>	1.6

**Table 3:** SAR limit

#### 5. DEVICE UNDER TEST

##### 5.1. Dimensions

Dimensions	Millimetres
Height x Width x Depth	115.0 x 59.0 x 15.0
Overall Diagonal:	120.0
Display Diagonal:	75.0

**Table 4:** Dimensions

##### 5.2. Wireless Technology

Wireless Technology	Frequency Bands	Modes
Wi-Fi	2.4 GHz	- 802.11b/g/n(20MHz & 40MHz)
Bluetooth		- Bluetooth BR, EDR2, EDR3 and Low Energy
ANT+		- ANT+

**Table 5:** DUT supported modes

##### 5.3. Simultaneous Transmission

The device under test doesn't support simultaneous transmission.

##### 5.4. DUT Antenna Location

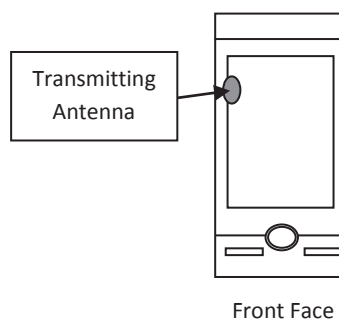

**Figure 3:** DUT Antenna diagram location

## Appendix B – Test results

## INDEX

1.	TEST CONDITIONS .....	20
1.1.	Power supply (V): .....	20
1.2.	Temperature (°C):.....	20
1.3.	Test signal, Output Power and Frequencies .....	20
1.4.	DUT and test-site configurations .....	20
2.	CONDUCTED AVERAGE POWER MEASUREMENTS.....	21
2.1.	Wi-Fi & Bluetooth .....	21
3.	TISSUE PARAMETERS MEASUREMENTS .....	23
4.	SYSTEM CHECK MEASUREMENTS.....	23
4.1.	Validation results for Body TSL .....	23
5.	MEASUREMENT RESULTS FOR SAR (SPECIFIC ABSORPTION RATE) .....	24
5.1.	Summary maximum results for 1-g body SAR measurements .....	24
5.2.	Results for Wi-Fi 2450 MHz Band.....	24
5.3.	Results for Bluetooth BR 2450MHz Band.....	25
5.4.	Variability results .....	25

## 1. TEST CONDITIONS

### 1.1. Power supply (V):

$V_n = 3.7$  Li-Ion polymer rechargeable battery

Type of power supply = DC Voltage from rechargeable Li-Ion 3.7 V battery.

### 1.2. Temperature (°C):

$T_n = +20.00$  to  $+25.00$

The subscript n indicates normal test conditions.

### 1.3. Test signal, Output Power and Frequencies

For the 802.11a/b/g/n, Bluetooth LE and ANT+ modes, the device was put into operation by using a manufacturer proprietary test mode, setting the maximum output power for each mode. For Bluetooth normal modes, the device was put into operation by using an Anritsu MT8852A Bluetooth testing unit.

The actual SAR sample does not have accessible antenna connectors for conducted measurements, so the conducted average output power was measured using others identical samples (M/01) provided by the manufacturer with auxiliary external connectors that makes the measurements representative and applicable for all the tested samples. See 'usage of samples' paragraph of this report.

The maximum conducted time-averaged power of the device for each mode was measured with a power sensor R&S NRP-Z81.

A fully charged battery was used for every test sequence. In all operating bands and test positions, the measurements were performed on the middle channel. In each band, for those positions where the maximum averaged SAR was found, measurements were performed on the remaining required channels except those with applicable test reductions <sup>2</sup>.

2: See remarks and comments

The target power alignments for RF components declared by the manufacturer for each supported technology are:

Band	Maximum Output Power (dBm)			
	802.11b	802.11g	802.11n20	802.11n40
2.45 GHz	17.7	15.2	14.0	13.8

Band	Maximum Output Power (dBm)		
	Bluetooth	Bluetooth LE	ANT+
2.45 GHz	8.5	2.0	-7.5

### 1.4. DUT and test-site configurations

The DUT was placed with each face position against the flat phantom surface, the separation distance between DUT and flat phantom surface was 5 mm for body-worn exposure testing.

## 2. CONDUCTED AVERAGE POWER MEASUREMENTS

### 2.1. Wi-Fi & Bluetooth

#### - 2.4 GHz Band:

Band	Mode	Channel / Freq (MHz)	Average Output Power (dBm)
2.4 GHz	802.11b	1/2412	16.76
		6/2437	16.84
		11/247	16.88
	802.11g	1/2412	12.39
		6/2437	13.65
		11/247	12.83
	802.11n20	1/2412	12.20
		6/2437	13.43
		11/247	12.62
	802.11n40	3/2422	7.95
7/2442		12.97	
9/2452		8.49	

Band	Mode	Channel / Freq (MHz)	Average Output Power (dBm)
2.4 GHz	Bluetooth BR (GFSK)	0 / 2402	8.15
		39 / 2441	8.23
		78 / 2480	8.45
	Bluetooth EDR2 ( $\pi/4$ -DQPSK)	0 / 2402	7.14
		39 / 2441	7.27
		78 / 2480	7.69
	Bluetooth EDR3 (8-DPSK)	0 / 2402	7.09
		39 / 2441	7.24
		78 / 2480	7.66
	Bluetooth LE	0 / 2402	1.0
		19 / 2440	0.9
		39 / 2480	0.48

Band	Mode	Channel / Freq (MHz)	Average Output Power (dBm)
2.4 GHz	ANT+	0 / 2402	-7.66
		39 / 2441	-7.64
		78 / 2480	-7.67

Based on paragraph “4.3.1 Standalone SAR test exclusion considerations” of the KDB 447498 D01 - General RF Exposure Guidance:

$$\left[ \frac{\text{(max. power of channel, including tune-up tolerance, mW)}}{\text{(min. test separation distance, mm)}} \right] \cdot [\sqrt{f(\text{GHz})}]$$

$\leq 3.0$  for 1-g SAR and  $\leq 7.5$  for 10-g extremity SAR

Protocol	Max. Conducted Output Power		Max. Declared Output Power		Min. Test Distance (mm)	Freq. (GHz)	Result	Test Exclusion
	(dBm)	(mW)	(dBm)	(mW)				
Bluetooth	8.45	6.99	8.5	7.08	5	2.480	2.23	√
Bluetooth LE	1.0	1.27	2.0	1.58	5	2.402	0.49	√
ANT+	-7.64	0.17	-7.5	0.18	5	2.441	0.06	√

The computed value is < 3.0 for the Bluetooth and ANT+ modes; therefore these transmission modes qualify for Standalone SAR test exclusion for 1-g SAR and 10-g SAR.

According to ISED RSS-102 Issue 5 (2015-03) – Radio Frequency Exposure Compliance of Radiocommunication Apparatus (All Frequency Bands), paragraph 2.5.1 Exemption Limits for Routine Evaluation – SAR Evaluation, if the device operates below the applicable output power level (adjusted for tune-up tolerance), for the specified separation distance defined in Table 1, SAR evaluation is not required. Output power level shall be the higher of the maximum conducted or equivalent isotropically radiated power (e.i.r.p.) source-based, time-averaged output power.

Protocol	Freq. (GHz)	Min. Test Distance (mm)	Max. Declared output power (dBm)	Max. Antenna gain (dBi)	Max. E.I.R.P. (dBm)	Max. E.I.R.P. (mW)	ISED RSS-102 Exemption limit (mW)	Test Exclusion
Bluetooth	2.45	5.0	8.5	1.1	9.6	9.12	4.0	X
Bluetooth LE			2	1.1	3.1	2.04		√
ANT+			-7.5	1.1	-6.4	0.23		√

As Bluetooth technology does not meet the ISED RSS-102 Exemption limit, SAR testing will be needed for this mode.

### 3. TISSUE PARAMETERS MEASUREMENTS

Frequency (MHz)	Target Body Tissue		Measured Body Tissue		Deviation %		Measured Date
	Permittivity $\epsilon$	Conductivity $\sigma$ [S/m]	Permittivity $\epsilon$	Conductivity $\sigma$ [S/m]	Permittivity $\epsilon$	Conductivity $\sigma$ [S/m]	
2450	52.7	1.95	51.17	2.01	-2.90	2.85	2017/07/05

Note: The dielectric properties have been measured by the contact probe method at 22° C.

#### - Composition / Information on ingredients

##### Head and Muscle Tissue Simulation Liquids HBBL1900-3800V3/M HBBL1900-3800V3

Water	50 – 73 %
Non-ionic detergents	27 – 50 % polyoxyethylenesorbitan monolaurate
NaCl	0 – 2 %
Preservative	0.05 – 0.1% Preventol-D7
Safety relevant ingredients:	
CAS-No. 55965-84-9	< 0.1 % aqueous preparation, containing 5-chloro-2-methyl-3(2H)-isothiazolone and 2-methyl-3(2H)-isothiazolone
CAS-No. 9005-64-5	<50 % polyoxyethylenesorbitan monolaurate

### 4. SYSTEM CHECK MEASUREMENTS

#### 4.1. Validation results for Body TSL

Date	Frequency (MHz)	SAR over	Estimated SAR (W/kg)	SAR W/kg)	$\Delta$ SAR - Estimated SAR	1 W Target SAR (W/kg)	1 W Norm. SAR (W/kg)	Drift (%)
2017/07/05	2450	1 gr.	12.60	12.40	< $\pm$ 3%	52.1	49.37	-5.24
		10 gr.	5.68	5.71	< $\pm$ 7%	24.4	22.74	-6.82

## 5. MEASUREMENT RESULTS FOR SAR (SPECIFIC ABSORPTION RATE)

### 5.1. Summary maximum results for 1-g body SAR measurements.

Band	Mode	Position/ Distance	Channel (Frequency)	Reported SAR SAR 1-g (W/kg)	SAR limit SAR 1-g (W/kg)
2450 MHz	802.11b	Back Face / 5 mm	CH 6 (2437 MHz)	0.638	1.6

### 5.2. Results for Wi-Fi 2450 MHz Band.

Side / Position	Dist (mm)	Mode	Channel	Freq (MHz)	Estimated SAR 1-g (W/kg)	SAR 1-g (W/kg)	Power Drift (%)	Scale factor	Reported SAR 1-g (W/kg)	Plot No.
Front face	5	802.11b	6	2437	0.261	NM <sup>1</sup>	0.35	1.219	0.318	
Back face	5	802.11b	6	2437	0.453	0.522	-0.12	1.219	0.638	1
Back face	5	802.11b	1	2412	0.315	0.37	0.69	1.242	0.459	
Back face	5	802.11b	11	2462	0.291	0.327	0.12	1.208	0.395	

1: See remarks and comments.

#### - 2.4 GHz 802.11g/n OFDM modes

The highest reported SAR for 802.11b mode and worst case exposure condition is 0.638 W/Kg.

802.11 b Max declared Power = 17.7 dBm → 58.88 mW

802.11 g Max declared Power = 15.2 dBm → 33.11 mW

802.11 n20 Max declared Power = 14.0 dBm → 25.12 mW

802.11 n40 Max declared Power = 13.8 dBm → 23.99 mW

Adjusted SAR for 802.11g:  $0.638 \text{ W/Kg} \times (33.11/58.88) = 0.36 \text{ W/Kg}$

Adjusted SAR for 802.11n20:  $0.638 \text{ W/Kg} \times (25.12/58.88) = 0.27 \text{ W/Kg}$

Adjusted SAR for 802.11n40:  $0.638 \text{ W/Kg} \times (23.99/58.88) = 0.26 \text{ W/Kg}$

As Adjusted SAR value for all 2.4 GHz 802.11g/n OFDM modes is  $\leq 1.2 \text{ W/Kg}$ , SAR measurements are not required for these 802.11 g/n OFDM modes.



### 5.3. Results for Bluetooth BR 2450MHz Band

Side / Position	Dist (mm)	Mode	Channel	Freq (MHz)	Estimated SAR 1-g (W/kg)	SAR 1-g (W/kg)	Power Drift (%)	Scale factor	Reported SAR 1-g (W/kg)	Plot No.
Front face	5	BR	40	2441	0.0283	NM <sup>1</sup>	1.04	1.012	0.029	
Back face	5	BR	40	2441	0.0305	0.033	1.27	1.012	0.033	
Back face	5	BR	0	2402	0.0291	0.027	0.93	1.012	0.027	
Back face	5	BR	79	2480	0.0625	0.057	2.57	1.012	0.058	2

1: See remarks and comments.

### 5.4. Variability results.

According to KDB 865664 D01 SAR Measurement 100 MHz to 6 GHz, paragraph “2.8.1. SAR measurement variability”, repeated measurements are required only when the measured SAR is  $\geq 0.80$  W/kg.

## Appendix C – Measurement report

## 802.11b – 2.4 GHz – Body – Back Face, d=5mm – Middle Channel – Plot N° 1

Test Laboratory: DEKRA Testing and Certification, S.A.U; Date: 2017-07-05

DUT: Sigma Rox 12.0; Type: Bicycle Computer; Serial: S/N:12517J00074

Communication System: UID 10012 - CAB, IEEE 802.11b WiFi 2.4 GHz (DSSS, 1 Mbps); Frequency: 2437 MHz; Duty Cycle: 1:1.53815

Medium parameters used (interpolated):  $f = 2437$  MHz;  $\sigma = 1.997$  S/m;  $\epsilon_r = 51.29$ ;  $\rho = 1000$  kg/m<sup>3</sup>

Phantom section: Flat Section

DASY5 Configuration:

- Probe: EX3DV4 - SN7461; ConvF(7.99, 7.99, 7.99); Calibrated: 2017-05-26;
- Sensor-Surface: 3mm (Mechanical Surface Detection (Locations From Previous Scan Used)), Sensor-Surface: 4mm (Mechanical Surface Detection)
- Electronics: DAE4 Sn669; Calibrated: 2016-07-18
- Phantom: Flat Phantom ELI4.0; Type: QDOVA001BA; Serial: SN:1060
- Measurement SW: DASY52, Version 52.8 (8); SEMCAD X Version 14.6.10 (7331)

### Faces, d=5mm/Back Face, 802.11b, Mid CH/Area Scan (81x121x1):

Interpolated grid: dx=1.200 mm, dy=1.200 mm

Info: [Interpolated medium parameters used for SAR evaluation.](#)

Maximum value of SAR (interpolated) = 0.593 W/kg

### Faces, d=5mm/Back Face, 802.11b, Mid CH/Zoom Scan (7x7x7)/Cube 0:

Measurement grid: dx=5mm, dy=5mm, dz=5mm

Reference Value = 10.61 V/m; Power Drift = -0.01 dB

Peak SAR (extrapolated) = 1.09 W/kg

**SAR(1 g) = 0.522 W/kg; SAR(10 g) = 0.237 W/kg** (SAR corrected for target medium)

Info: [Interpolated medium parameters used for SAR evaluation.](#)

Maximum value of SAR (measured) = 0.605 W/kg

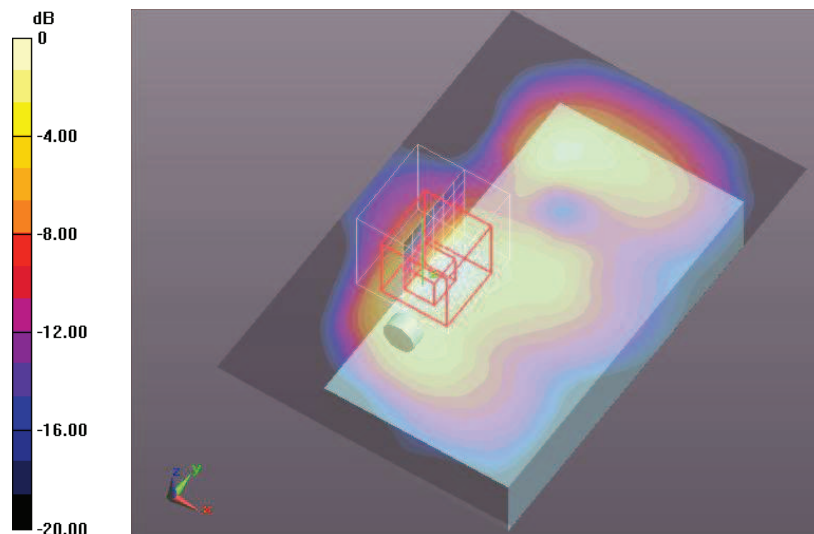

0 dB = 0.605 W/kg = -2.18 dBW/kg

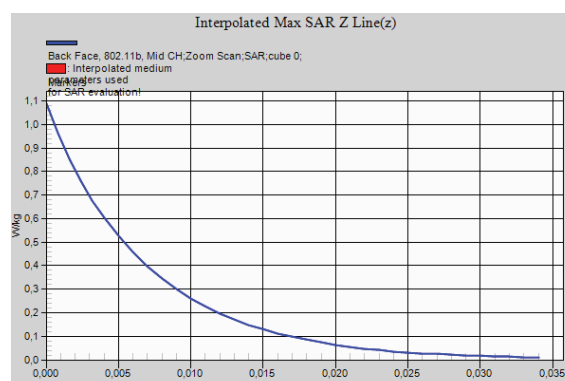

**Bluetooth BR – 2.4 GHz – Body – Back Face, d=5mm – Highest Channel – Plot N° 2**

**Test Laboratory: DEKRA Testing and Certification, S.A.U; Date: 2017-07-06**

**DUT: Sigma Rox 12.0; Type: Bicycle Computer; Serial: S/N:12517J00074**

Communication System: UID 10032 - CAA, IEEE 802.15.1 Bluetooth (GFSK, DH5); Frequency: 2480 MHz; Duty Cycle: 1:1.30617

Medium parameters used:  $f = 2480$  MHz;  $\sigma = 2.06$  S/m;  $\epsilon_r = 51.04$ ;  $\rho = 1000$  kg/m<sup>3</sup>

Phantom section: Flat Section

DASY5 Configuration:

- Probe: EX3DV4 - SN7461; ConvF(7.99, 7.99, 7.99); Calibrated: 2017-05-26;
- Sensor-Surface: 3mm (Mechanical Surface Detection (Locations From Previous Scan Used)), Sensor-Surface: 4mm (Mechanical Surface Detection)
- Electronics: DAE4 Sn669; Calibrated: 2016-07-18
- Phantom: Flat Phantom ELI4.0; Type: QDOVA001BA; Serial: SN:1060
- Measurement SW: DASY52, Version 52.8 (8); SEMCAD X Version 14.6.10 (7331)

**Faces, d=5mm/Back Face, 802.15.1, GFSK, High/Area Scan (81x121x1):**

Interpolated grid:  $dx=1.200$  mm,  $dy=1.200$  mm

Maximum value of SAR (interpolated) = 0.100 W/kg

**Faces, d=5mm/Back Face, 802.15.1, GFSK, High/Zoom Scan (7x7x7)/Cube 0:**

Measurement grid:  $dx=5$ mm,  $dy=5$ mm,  $dz=5$ mm

Reference Value = 3.317 V/m; Power Drift = 0.22 dB

Peak SAR (extrapolated) = 0.150 W/kg

**SAR(1 g) = 0.057 W/kg; SAR(10 g) = 0.025 W/kg** (SAR corrected for target medium)

Maximum value of SAR (measured) = 0.0674 W/kg

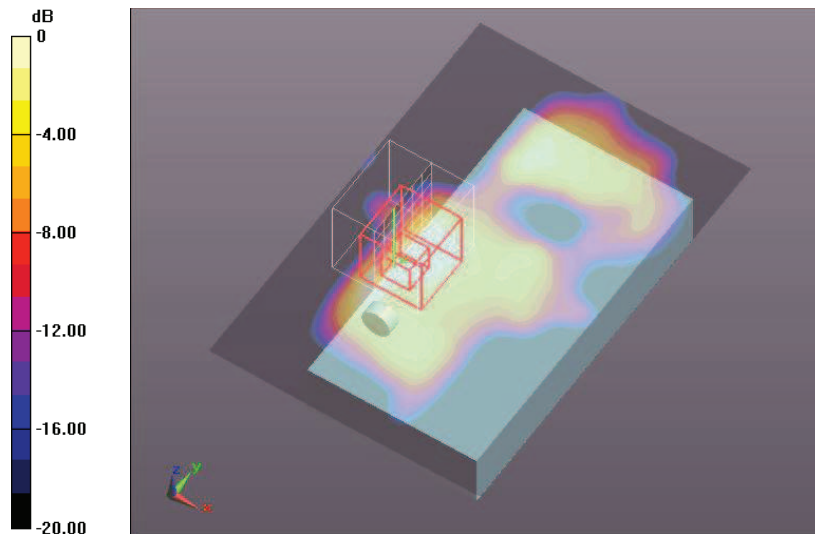

0 dB = 0.0674 W/kg = -11.71 dBW/kg

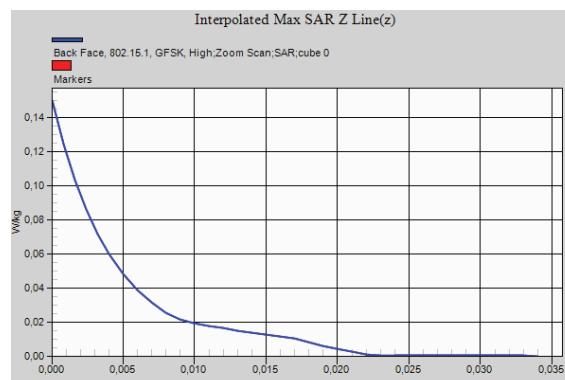

## Appendix D – System Validation Reports

**Validation results in 2450 MHz Band for Body TSL**

**Test Laboratory: DEKRA Testing and Certification, S.A.U; Date: 2017-07-05**

**DUT: Dipole 2450 MHz D2450V2; Type: D2450V2; Serial: D2450V2 - SN:756**

Communication System: UID 0, CW (0); Frequency: 2450 MHz; Duty Cycle: 1:1

Medium parameters used:  $f = 2450$  MHz;  $\sigma = 2.01$  S/m;  $\epsilon_r = 51.17$ ;  $\rho = 1000$  kg/m<sup>3</sup>

Phantom section: Flat Section

DASY5 Configuration:

- Probe: EX3DV4 - SN7461; ConvF(7.99, 7.99, 7.99); Calibrated: 2017-05-26;
- Sensor-Surface: 3mm (Mechanical Surface Detection)
- Electronics: DAE4 Sn669; Calibrated: 2016-07-18
- Phantom: Flat Phantom ELI4.0; Type: QDOVA001BA; Serial: SN:1060
- Measurement SW: DASY52, Version 52.8 (8); SEMCAD X Version 14.6.10 (7331)

**Configuration 2450 MHz, 2017-07-05/d=10mm, Pin=250 mW/Area Scan (101x101x1):**

Interpolated grid: dx=1.000 mm, dy=1.000 mm

Maximum value of SAR (interpolated) = 16.6 W/kg

**Configuration 2450 MHz, 2017-07-05/d=10mm, Pin=250 mW/Zoom Scan (7x7x7)/Cube 0:**

Measurement grid: dx=5mm, dy=5mm, dz=5mm

Reference Value = 87.37 V/m; Power Drift = 0.09 dB

Peak SAR (extrapolated) = 25.5 W/kg

**SAR(1 g) = 12.4 W/kg; SAR(10 g) = 5.71 W/kg** (SAR corrected for target medium)

Maximum value of SAR (measured) = 16.4 W/kg

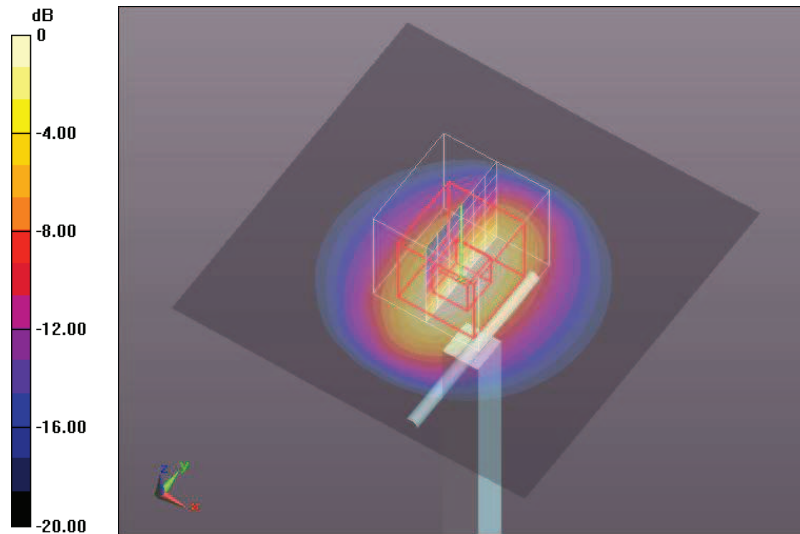

0 dB = 16.4 W/kg = 12.15 dBW/kg

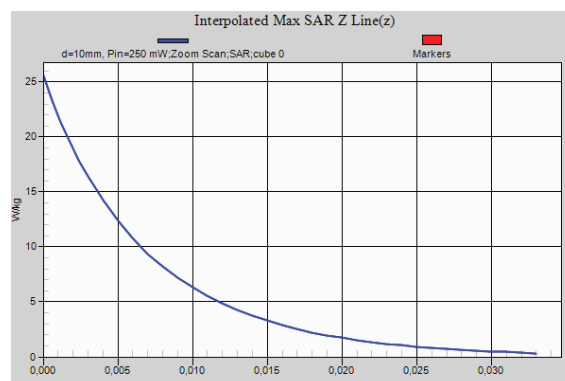

## Appendix E – Calibration data

**Calibration Laboratory of  
 Schmid & Partner  
 Engineering AG**  
 Zaugghausstrasse 43, 8004 Zurich, Switzerland



**S** Schweizerischer Kalibrierdienst  
**S** Service suisse d'étalonnage  
**C** Servizio svizzero di taratura  
**S** Swiss Calibration Service

Accredited by the Swiss Accreditation Service (SAS)  
 The Swiss Accreditation Service is one of the signatories to the EA  
 Multilateral Agreement for the recognition of calibration certificates

Accreditation No.: **SCS 0108**

Client **AT4 Wireless**

Certificate No: **DAE4-669\_Jul16**

### CALIBRATION CERTIFICATE

Object: **DAE4 - SD 000 D04 BM - SN: 669**

Calibration procedure(s): **QA CAL-06 v29  
 Calibration procedure for the data acquisition electronics (DAE)**

Calibration date: **July 18, 2016**

This calibration certificate documents the traceability to national standards, which realize the physical units of measurements (SI).  
 The measurements and the uncertainties with confidence probability are given on the following pages and are part of the certificate.

All calibrations have been conducted in the closed laboratory facility: environment temperature (22 ± 3)°C and humidity < 70%.

Calibration Equipment used (M&E critical for calibration)

Primary Standards	ID #	Cal Date (Certificate No.)	Scheduled Calibration
Ketley Multimeter Type 2001	SN: 0810276	09-Sep-15 (No.17153)	Sep-16
Secondary Standards	ID #	Check Date (in house)	Scheduled Check
Auto DAE Calibration Unit	SE LWS 063 AA 1001	06-Jan-16 (in house check)	in house check: Jan-17
Calibrator Box V2.1	SE UMS 006 AA 1002	05-Jan-16 (in house check)	in house check: Jan-17

Calibrated by:	Name Domingue Steffen	Function Technician	Signature 
Approved by:	Fr. Bortolt	Deputy Technical Manager	

Issued: July 18, 2016

This calibration certificate shall not be reproduced except in full without written approval of the laboratory.



Calibration Laboratory of  
Schmid & Partner  
Engineering AG  
Zeughausstrasse 43, 8004 Zurich, Switzerland



S Schweizerischer Kalibrierdienst  
C Service suisse d'étalonnage  
S Servizio svizzero di taratura  
S Swiss Calibration Service

Accredited by the Swiss Accreditation Service (SAS)  
The Swiss Accreditation Service is one of the signatories to the EA  
Multilateral Agreement for the recognition of calibration certificates

Accreditation No.: SCS 0108

## Glossary

DAE data acquisition electronics  
Connector angle information used in DASY system to align probe sensor X to the robot coordinate system.

## Methods Applied and Interpretation of Parameters

- *DC Voltage Measurement:* Calibration Factor assessed for use in DASY system by comparison with a calibrated instrument traceable to national standards. The figure given corresponds to the full scale range of the voltmeter in the respective range.
- *Connector angle:* The angle of the connector is assessed measuring the angle mechanically by a tool inserted. Uncertainty is not required.
- The following parameters as documented in the Appendix contain technical information as a result from the performance test and require no uncertainty.
  - *DC Voltage Measurement Linearity:* Verification of the Linearity at +10% and -10% of the nominal calibration voltage. Influence of offset voltage is included in this measurement.
  - *Common mode sensitivity:* Influence of a positive or negative common mode voltage on the differential measurement.
  - *Channel separation:* Influence of a voltage on the neighbor channels not subject to an input voltage.
  - *AD Converter Values with inputs shorted:* Values on the internal AD converter corresponding to zero input voltage
  - *Input Offset Measurement:* Output voltage and statistical results over a large number of zero voltage measurements.
  - *Input Offset Current:* Typical value for information; Maximum channel input offset current, not considering the input resistance.
  - *Input resistance:* Typical value for information: DAE input resistance at the connector, during internal auto-zeroing and during measurement.
  - *Low Battery Alarm Voltage:* Typical value for information. Below this voltage, a battery alarm signal is generated.
  - *Power consumption:* Typical value for information. Supply currents in various operating modes.

### DC Voltage Measurement

A/D - Converter Resolution nominal

High Range: 1LSB = 6.1 $\mu$ V, full range = -100...+300 mV

Low Range: 1LSB = 61nV, full range = -1.....+3mV

DASY measurement parameters: Auto Zero Time: 3 sec; Measuring time: 3 sec

Calibration Factors	X	Y	Z
High Range	403.329 $\pm$ 0.02% (k=2)	403.860 $\pm$ 0.02% (k=2)	404.240 $\pm$ 0.02% (k=2)
Low Range	3.95541 $\pm$ 1.50% (k=2)	3.97473 $\pm$ 1.50% (k=2)	3.97419 $\pm$ 1.50% (k=2)

### Connector Angle

Connector Angle to be used in DASY system	192,0° $\pm$ 1°
---	-----------------

**Appendix (Additional assessments outside the scope of SCS0108)**

**1. DC Voltage Linearity**

High Range		Reading ( $\mu$ V)	Difference ( $\mu$ V)	Error (%)
Channel X	+ Input	200036.84	-0.47	-0.00
Channel X	+ Input	20009.62	4.22	0.02
Channel X	- Input	-20001.84	3.36	-0.02
Channel Y	+ Input	200035.95	-1.37	-0.00
Channel Y	+ Input	20008.11	2.95	0.01
Channel Y	- Input	-20003.03	2.32	-0.01
Channel Z	+ Input	200036.35	-2.70	-0.00
Channel Z	+ Input	20008.67	3.78	0.02
Channel Z	- Input	-20003.08	2.25	-0.01

Low Range		Reading ( $\mu$ V)	Difference ( $\mu$ V)	Error (%)
Channel X	+ Input	2001.08	-0.33	-0.02
Channel X	+ Input	201.62	0.14	0.07
Channel X	- Input	-198.88	-0.36	0.18
Channel Y	+ Input	2001.32	0.23	0.01
Channel Y	+ Input	200.95	-0.29	-0.14
Channel Y	- Input	-199.87	-1.04	0.52
Channel Z	+ Input	2001.30	0.12	0.01
Channel Z	+ Input	200.62	-0.62	-0.31
Channel Z	- Input	-200.16	-1.41	0.71

**2. Common mode sensitivity**

DASY measurement parameters: Auto Zero Time: 3 sec; Measuring time: 3 sec

	Common mode Input Voltage (mV)	High Range Average Reading ( $\mu$ V)	Low Range Average Reading ( $\mu$ V)
Channel X	200	2.15	0.63
	-200	0.50	-1.00
Channel Y	200	10.89	10.66
	-200	-13.07	-13.28
Channel Z	200	-10.00	-10.04
	-200	7.66	7.47

**3. Channel separation**

DASY measurement parameters: Auto Zero Time: 3 sec; Measuring time: 3 sec

	Input Voltage (mV)	Channel X ( $\mu$ V)	Channel Y ( $\mu$ V)	Channel Z ( $\mu$ V)
Channel X	200	-	-2.46	-2.83
Channel Y	200	8.89	-	-1.72
Channel Z	200	2.97	6.84	-

#### 4. AD-Converter Values with inputs shorted

DASY measurement parameters: Auto Zero Time: 3 sec; Measuring time: 3 sec

	High Range (LSB)	Low Range (LSB)
Channel X	16074	15743
Channel Y	15795	15269
Channel Z	15996	15139

#### 5. Input Offset Measurement

DASY measurement parameters: Auto Zero Time: 3 sec; Measuring time: 3 sec

Input 10M $\Omega$

	Average ( $\mu$ V)	min. Offset ( $\mu$ V)	max. Offset ( $\mu$ V)	Std. Deviation ( $\mu$ V)
Channel X	0.25	-1.07	2.29	0.53
Channel Y	0.36	-0.99	1.48	0.38
Channel Z	0.05	-1.09	2.02	0.46

#### 6. Input Offset Current

Nominal input circuitry offset current on all channels: <25fA

#### 7. Input Resistance (Typical values for information)

	Zeroing (k $\Omega$ m)	Measuring (M $\Omega$ m)
Channel X	200	200
Channel Y	200	200
Channel Z	200	200

#### 8. Low Battery Alarm Voltage (Typical values for information)

Typical values	Alarm Level (VDC)
Supply (+ Vcc)	+7.9
Supply (- Vcc)	-7.6

#### 9. Power Consumption (Typical values for information)

Typical values	Switched off (mA)	Stand by (mA)	Transmitting (mA)
Supply (+ Vcc)	+0.01	+6	+14
Supply (- Vcc)	-0.01	-8	-9

**Calibration Laboratory of  
 Schmid & Partner  
 Engineering AG**  
 Zeughausstrasse 43, 8004 Zurich, Switzerland



**S** Schweizerischer Kalibrierdienst  
**S** Service suisse d'étalonnage  
**S** Servizio svizzero di taratura  
**S** Swiss Calibration Service

Accredited by the Swiss Accreditation Service (SAS)  
 The Swiss Accreditation Service is one of the signatories to the EA  
 Multilateral Agreement for the recognition of calibration certificates

Accreditation No.: **SCS 0108**

Client **DEKRA**

Certificate No: **EX3-7461\_May17**

### CALIBRATION CERTIFICATE

Object: **EX3DV4 - SN:7461**

Calibration procedure(s): **QA CAL-01.v9, QA CAL-12.v9, QA CAL-14.v4, QA CAL-23.v5,  
 QA CAL-25.v6  
 Calibration procedure for dosimetric E-field probes**

Calibration date: **May 26, 2017**

This calibration certificate documents the traceability to national standards, which realize the physical units of measurements (SI).  
 The measurements and the uncertainties with confidence probability are given on the following pages and are part of the certificate.

All calibrations have been conducted in the closed laboratory facility; environment temperature (22 ± 3)°C and humidity < 70%.

Calibration Equipment used (M&TE critical for calibration)

Primary Standards	ID	Cal Date (Certificate No.)	Scheduled Calibration
Power meter NRP	SN: 104778	04-Apr-17 (No. 217-02521/02522)	Apr-18
Power sensor NRP-Z91	SN: 103244	04-Apr-17 (No. 217-02521)	Apr-18
Power sensor NRP-Z91	SN: 103245	04-Apr-17 (No. 217-02525)	Apr-18
Reference 20 dB Attenuator	SN: 55277 (20x)	07-Apr-17 (No. 217-02528)	Apr-18
Reference Probe ES3DV2	SN: 3013	31-Dec-16 (No. ES3-3013_Dec16)	Dec-17
DAE4	SN: 660	7-Dec-16 (No. DAE4-660_Dec16)	Dec-17
Secondary Standards	ID	Check Date (in house)	Scheduled Check
Power meter E4419B	SN: GB41293674	06-Apr-16 (in house check Jun-16)	in house check: Jun-18
Power sensor E4412A	SN: MY41499087	05-Apr-16 (in house check Jun-16)	in house check: Jun-18
Power sensor E4412A	SN: 000110210	06-Apr-16 (in house check Jun-16)	in house check: Jun-18
RF generator HP 8648C	SN: US3642UD1700	04-Aug-99 (in house check Jun-16)	in house check: Jun-18
Network Analyzer HP 8753E	SN: US37390565	18-Oct-01 (in house check Oct-16)	in house check: Oct-17

Calibrated by: **Name: Michael Weber, Function: Laboratory Technician, Signature: [Signature]**

Approved by: **Name: Katja Pokovic, Function: Technical Manager, Signature: [Signature]**

Issued: **May 31, 2017**

This calibration certificate shall not be reproduced except in full without written approval of the laboratory.

Certificate No: **EX3-7461\_May17**

Page 1 of 38

**Calibration Laboratory of  
Schmid & Partner  
Engineering AG**  
Zeughausstrasse 43, 8004 Zurich, Switzerland



**S** Schweizerischer Kalibrierdienst  
**C** Service suisse d'étalonnage  
**S** Servizio svizzero di taratura  
**S** Swiss Calibration Service

Accredited by the Swiss Accreditation Service (SAS)

Accreditation No.: **SCS 0108**

The Swiss Accreditation Service is one of the signatories to the EA  
Multilateral Agreement for the recognition of calibration certificates

**Glossary:**

TSL	tissue simulating liquid
NORM <sub>x,y,z</sub>	sensitivity in free space
ConvF	sensitivity in TSL / NORM <sub>x,y,z</sub>
DCP	diode compression point
CF	crest factor (1/duty_cycle) of the RF signal
A, B, C, D	modulation dependent linearization parameters
Polarization $\varphi$	$\varphi$ rotation around probe axis
Polarization $\theta$	$\theta$ rotation around an axis that is in the plane normal to probe axis (at measurement center), i.e., $\theta = 0$ is normal to probe axis
Connector Angle	information used in DASY system to align probe sensor X to the robot coordinate system

**Calibration is Performed According to the Following Standards:**

- IEEE Std 1526-2013, "IEEE Recommended Practice for Determining the Peak Spatial-Averaged Specific Absorption Rate (SAR) in the Human Head from Wireless Communications Devices: Measurement Techniques", June 2013
- IEC 62209-1, "Procedure to measure the Specific Absorption Rate (SAR) for hand-held devices used in close proximity to the ear (frequency range of 300 MHz to 3 GHz)", February 2005
- IEC 62209-2, "Procedure to determine the Specific Absorption Rate (SAR) for wireless communication devices used in close proximity to the human body (frequency range of 30 MHz to 6 GHz)", March 2010
- KDB 865664, "SAR Measurement Requirements for 100 MHz to 6 GHz"

**Methods Applied and Interpretation of Parameters:**

- NORM<sub>x,y,z</sub>:** Assessed for E-field polarization  $\theta = 0$  ( $f \leq 900$  MHz in TEM-cell;  $f > 1800$  MHz: R22 waveguide). NORM<sub>x,y,z</sub> are only intermediate values, i.e., the uncertainties of NORM<sub>x,y,z</sub> does not affect the E<sup>2</sup>-field uncertainty inside TSL (see below ConvF).
- NORM(f)<sub>x,y,z</sub> = NORM<sub>x,y,z</sub> \* frequency\_response** (see Frequency Response Chart). This linearization is implemented in DASY4 software versions later than 4.2. The uncertainty of the frequency response is included in the stated uncertainty of ConvF.
- DCP<sub>x,y,z</sub>:** DCP are numerical linearization parameters assessed based on the data of power sweep with CW signal (no uncertainty required). DCP does not depend on frequency nor media.
- PAR:** PAR is the Peak to Average Ratio that is not calibrated but determined based on the signal characteristics
- A<sub>x,y,z</sub>; B<sub>x,y,z</sub>; C<sub>x,y,z</sub>; D<sub>x,y,z</sub>; VR<sub>x,y,z</sub>:** A, B, C, D are numerical linearization parameters assessed based on the data of power sweep for specific modulation signal. The parameters do not depend on frequency nor media. VR is the maximum calibration range expressed in RMS voltage across the diode.
- ConvF and Boundary Effect Parameters:** Assessed in flat phantom using E-field (or Temperature Transfer Standard for  $f \leq 800$  MHz) and inside waveguide using analytical field distributions based on power measurements for  $f > 800$  MHz. The same setups are used for assessment of the parameters applied for boundary compensation (alpha, depth) of which typical uncertainty values are given. These parameters are used in DASY4 software to improve probe accuracy close to the boundary. The sensitivity in TSL corresponds to NORM<sub>x,y,z</sub> \* ConvF whereby the uncertainty corresponds to that given for ConvF. A frequency dependent ConvF is used in DASY version 4.4 and higher which allows extending the validity from  $\pm 50$  MHz to  $\pm 100$  MHz.
- Spherical isotropy (3D deviation from isotropy):** in a field of low gradients realized using a flat phantom exposed by a patch antenna.
- Sensor Offset:** The sensor offset corresponds to the offset of virtual measurement center from the probe tip (on probe axis). No tolerance required.
- Connector Angle:** The angle is assessed using the information gained by determining the NORM<sub>x</sub> (no uncertainty required).

EX3DV4 – SN:7461

May 26, 2017

# Probe EX3DV4

## SN:7461

Manufactured: September 6, 2016  
Calibrated: May 26, 2017

Calibrated for DASY/EASY Systems  
(Note: non-compatible with DASY2 system!)

---

Certificate No: EX3-7461\_May17

Page 3 of 38

EX3DV4- SN:7461

May 28, 2017

## DASY/EASY - Parameters of Probe: EX3DV4 - SN:7461

### Basic Calibration Parameters

	Sensor X	Sensor Y	Sensor Z	Unc (k=2)
Norm ( $\mu\text{V}/(\text{V}/\text{m})^2$ ) <sup>A</sup>	0.45	0.40	0.45	$\pm 10.1\%$
DCP ( $\text{mV}^3$ )	97.0	98.5	96.3	

### Modulation Calibration Parameters

UID	Communication System Name		A dB	B dB $\sqrt{\mu\text{V}}$	C	D dB	VR mV	Unc <sup>C</sup> (k=2)
0	CW	X	0.0	0.0	1.0	0.00	134.0	$\pm 3.5\%$
		Y	0.0	0.0	1.0		139.2	
		Z	0.0	0.0	1.0		129.1	

Note: For details on UID parameters see Appendix.

### Sensor Model Parameters

	C1 fF	C2 fF	$\alpha$ $\text{V}^{-1}$	T1 $\text{ms}\cdot\text{V}^{-2}$	T2 $\text{ms}\cdot\text{V}^{-1}$	T3 ms	T4 $\text{V}^{-2}$	T5 $\text{V}^{-1}$	T6
X	54.48	406.8	35.75	8.114	0.821	4.932	1.556	0.228	1.002
Y	49.37	369.4	35.91	6.613	0.788	4.929	0.534	0.284	1.001
Z	46.73	348.8	35.68	6.950	0.794	4.941	1.603	0.180	1.002

The reported uncertainty of measurement is stated as the standard uncertainty of measurement multiplied by the coverage factor  $k=2$ , which for a normal distribution corresponds to a coverage probability of approximately 95%.

<sup>A</sup> The uncertainties of Norm X,Y,Z do not affect the E<sup>2</sup>-field uncertainty inside TSL (see Pages 5 and 6).

<sup>B</sup> Numerical linearization parameter: uncertainty not required.

<sup>C</sup> Uncertainty is determined using the max. deviation from linear response applying rectangular distribution and is expressed for the square of the field value.



EX3DV4- SN:7461

May 28, 2017

## DASY/EASY - Parameters of Probe: EX3DV4 - SN:7461

### Calibration Parameter Determined in Head Tissue Simulating Media

f (MHz) <sup>c</sup>	Relative Permittivity <sup>e</sup>	Conductivity (S/m) <sup>e</sup>	ConvF X	ConvF Y	ConvF Z	Alpha <sup>d</sup>	Depth (mm) <sup>d</sup>	Unc (k=2)
450	43.5	0.87	11.11	11.11	11.11	0.14	1.20	± 13.3 %
750	41.9	0.89	10.37	10.37	10.37	0.43	0.91	± 12.0 %
835	41.5	0.90	10.04	10.04	10.04	0.51	0.82	± 12.0 %
900	41.5	0.97	9.83	9.83	9.83	0.33	1.01	± 12.0 %
1640	40.2	1.31	8.62	8.62	8.62	0.36	0.80	± 12.0 %
1750	40.1	1.37	8.57	8.57	8.57	0.33	0.83	± 12.0 %
1900	40.0	1.40	8.34	8.34	8.34	0.31	0.80	± 12.0 %
2000	40.0	1.40	8.16	8.16	8.16	0.33	0.80	± 12.0 %
2100	39.8	1.49	8.39	8.39	8.39	0.32	0.85	± 12.0 %
2300	39.5	1.67	8.02	8.02	8.02	0.38	0.80	± 12.0 %
2450	39.2	1.80	7.91	7.91	7.91	0.39	0.80	± 12.0 %
2600	39.0	1.96	7.52	7.52	7.52	0.36	0.80	± 12.0 %
5200	36.0	4.66	6.04	6.04	6.04	0.35	1.80	± 13.1 %
5500	35.9	4.76	5.84	5.84	5.84	0.35	1.80	± 13.1 %
5600	35.5	5.07	5.16	5.16	5.16	0.40	1.80	± 13.1 %
5800	35.3	5.27	5.38	5.38	5.38	0.40	1.80	± 13.1 %

<sup>c</sup> Frequency validity above 300 MHz of ± 100 MHz only applies for DASY v4.4 and higher (see Page 2), else it is restricted to ± 50 MHz. The uncertainty is the RSS of the ConvF uncertainty at calibration frequency and the uncertainty for the indicated frequency band. Frequency validity below 300 MHz is ± 10, 25, 40, 50 and 70 MHz for ConvF assessments at 30, 64, 128, 150 and 220 MHz respectively. Above 5 GHz frequency validity can be extended to ± 110 MHz.

<sup>e</sup> At frequencies below 3 GHz, the validity of tissue parameters ( $\epsilon$  and  $\sigma$ ) can be relaxed to ± 10% if liquid compensation formula is applied to measured SAR values. At frequencies above 3 GHz, the validity of tissue parameters ( $\epsilon$  and  $\sigma$ ) is restricted to ± 5%. The uncertainty is the RSS of the ConvF uncertainty for indicated target tissue parameters.

<sup>d</sup> Alpha/Depth are determined during calibration. SPEAG warrants that the remaining deviation due to the boundary effect after compensation is always less than ± 1% for frequencies below 3 GHz and below ± 2% for frequencies between 3-6 GHz at any distance larger than half the probe tip diameter from the boundary.

EX3DV4- SN:7461

May 26, 2017

## DASY/EASY - Parameters of Probe: EX3DV4 - SN:7461

### Calibration Parameter Determined in Body Tissue Simulating Media

f (MHz) <sup>c</sup>	Relative Permittivity <sup>e</sup>	Conductivity (S/m) <sup>e</sup>	ConvF X	ConvF Y	ConvF Z	Alpha <sup>g</sup>	Depth (mm) <sup>g</sup>	Unc (k=2)
450	56.7	0.94	11.35	11.35	11.35	0.09	1.20	± 13.3 %
750	55.5	0.96	10.27	10.27	10.27	0.49	0.80	± 12.0 %
835	55.2	0.97	10.01	10.01	10.01	0.34	1.04	± 12.0 %
900	55.0	1.05	9.91	9.91	9.91	0.44	0.83	± 12.0 %
1640	53.7	1.42	8.69	8.69	8.69	0.38	0.84	± 12.0 %
1750	53.4	1.49	8.45	8.45	8.45	0.46	0.80	± 12.0 %
1900	53.3	1.52	8.14	8.14	8.14	0.42	0.86	± 12.0 %
2000	53.3	1.52	8.11	8.11	8.11	0.38	0.89	± 12.0 %
2450	52.7	1.95	7.99	7.99	7.99	0.34	0.85	± 12.0 %
2800	52.5	2.16	7.65	7.65	7.65	0.28	0.99	± 12.0 %
5200	49.0	5.30	5.33	5.33	5.33	0.35	1.90	± 13.1 %
5300	48.9	5.42	5.09	5.09	5.09	0.35	1.90	± 13.1 %
5800	48.5	5.77	4.49	4.49	4.49	0.40	1.90	± 13.1 %
5800	48.2	6.00	4.58	4.58	4.58	0.45	1.90	± 13.1 %

<sup>c</sup> Frequency validity above 300 MHz of ± 100 MHz only applies for DASY v4.4 and higher (see Page 2), else it is restricted to ± 50 MHz. The uncertainty is the RSS of the ConvF uncertainty at calibration frequency and the uncertainty for the indicated frequency band. Frequency validity below 300 MHz is ± 10, 25, 40, 50 and 70 MHz for ConvF assessments at 30, 64, 128, 150 and 220 MHz respectively. Above 5 GHz frequency validity can be extended to ± 110 MHz.

<sup>e</sup> At frequencies below 3 GHz, the validity of tissue parameters ( $\epsilon$  and  $\sigma$ ) can be relaxed to ± 10% if liquid compensation formula is applied to measured SAR values. At frequencies above 3 GHz, the validity of tissue parameters ( $\epsilon$  and  $\sigma$ ) is restricted to ± 5%. The uncertainty is the RSS of the ConvF uncertainty for indicated target tissue parameters.

<sup>g</sup> Alpha/Depth are determined during calibration. SPEAG warrants that the remaining deviation due to the boundary effect after compensation is always less than ± 1% for frequencies below 3 GHz and below ± 2% for frequencies between 3-6 GHz at any distance larger than half the probe tip diameter from the boundary.

EX3DV4-SN:7461

May 26, 2017

### Frequency Response of E-Field (TEM-Cell: ifi110 EXX, Waveguide: R22)

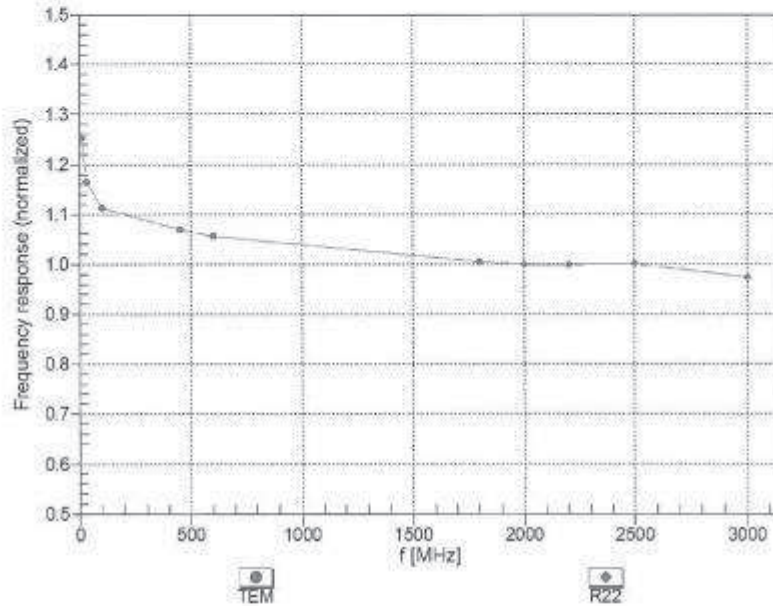

Uncertainty of Frequency Response of E-field:  $\pm 6.3\%$  (k=2)

EX3DV4- SN:7461

May 26, 2017

### Receiving Pattern ( $\phi$ ), $\theta = 0^\circ$

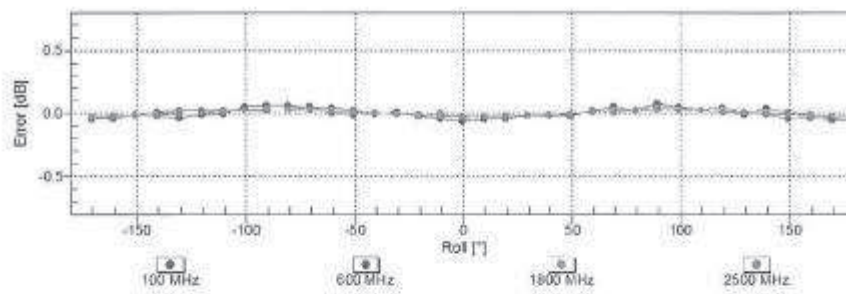
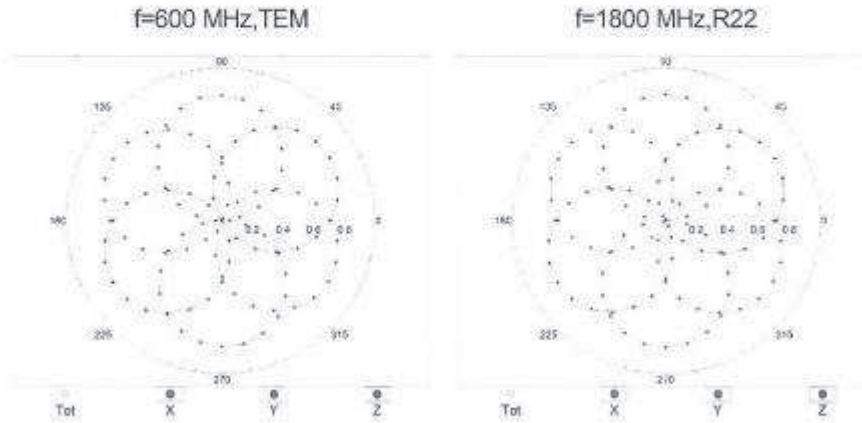

Uncertainty of Axial Isotropy Assessment:  $\pm 0.5\%$  ( $k=2$ )

EX3DV4- SN:7461

May 26, 2017

### Dynamic Range f(SAR<sub>head</sub>) (TEM cell , f<sub>eval</sub>= 1900 MHz)

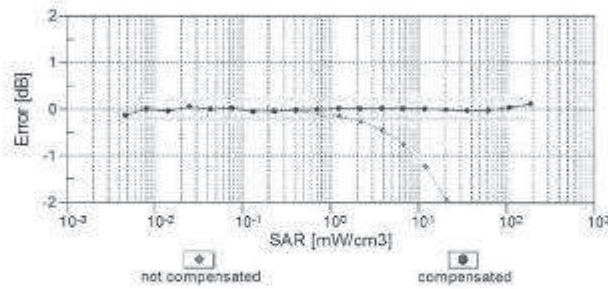
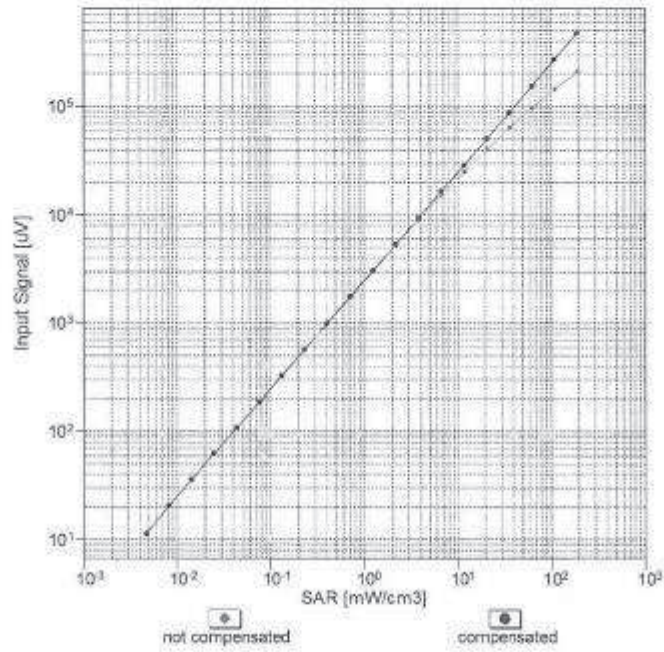

Uncertainty of Linearity Assessment: ± 0.6% (k=2)

EX3DV4-SN:7461

May 26, 2017

### Conversion Factor Assessment

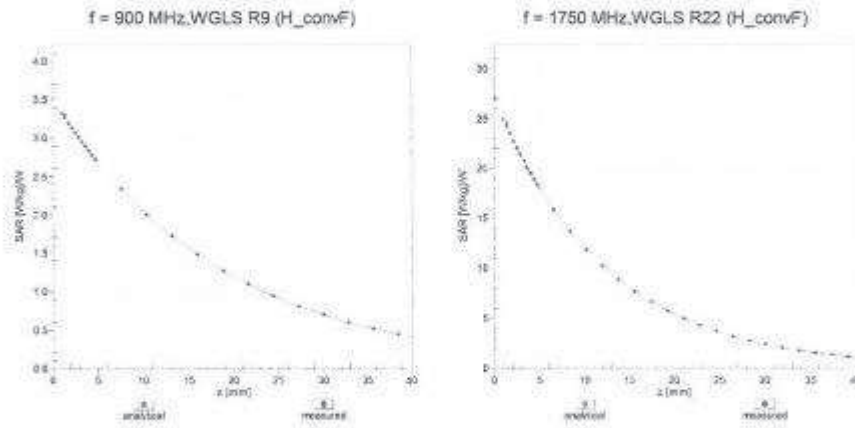

### Deviation from Isotropy in Liquid Error ( $\theta$ , $\vartheta$ ), f = 900 MHz

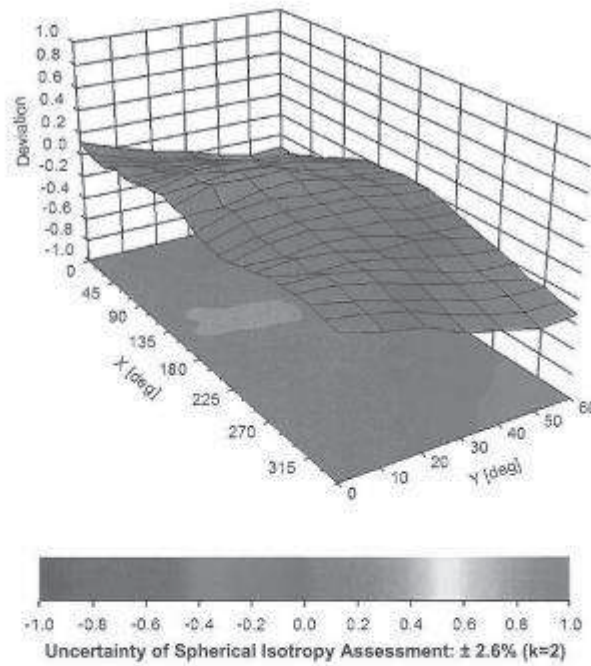

EX3DV4-SN:7461

May 26, 2017

## DASY/EASY - Parameters of Probe: EX3DV4 - SN:7461

### Other Probe Parameters

Sensor Arrangement	Triangular
Connector Angle (°)	99,2
Mechanical Surface Detection Mode	enabled
Optical Surface Detection Mode	disabled
Probe Overall Length	337 mm
Probe Body Diameter	10 mm
Tip Length	9 mm
Tip Diameter	2.5 mm
Probe Tip to Sensor X Calibration Point	1 mm
Probe Tip to Sensor Y Calibration Point	1 mm
Probe Tip to Sensor Z Calibration Point	1 mm
Recommended Measurement Distance from Surface	1.4 mm

EX3DV4-SN:7461

May 26, 2017

**Appendix: Modulation Calibration Parameters**

UID	Communication System Name		A dB	B dB·µV	C	D dB	VR mV	Max Unc <sup>E</sup> (k=2)
0	CW	X	0.00	0.00	1.00	0.00	134.0	± 3.5 %
		Y	0.00	0.00	1.00		139.2	
		Z	0.00	0.00	1.00		129.1	
10010- CAA	SAR Validation (Square, 100ms, 10ms)	X	2.01	63.06	8.51	10.00	20.0	± 9.6 %
		Y	2.02	63.14	8.54		20.0	
		Z	2.06	63.42	8.77		20.0	
10011- CAB	UMTS-FDD (WCDMA)	X	1.18	69.94	16.90	0.00	150.0	± 9.6 %
		Y	1.27	71.49	17.77		150.0	
		Z	1.09	68.68	16.12		150.0	
10012- CAB	IEEE 802.11b WiFi 2.4 GHz (DSSS, 1 Mbps)	X	1.15	63.93	15.45	0.41	150.0	± 9.6 %
		Y	1.16	64.23	15.75		150.0	
		Z	1.13	63.64	15.16		150.0	
10013- CAB	IEEE 802.11g WiFi 2.4 GHz (DSSS-OFDM, 6 Mbps)	X	4.84	66.29	16.78	1.46	150.0	± 9.6 %
		Y	4.80	66.40	16.87		150.0	
		Z	4.77	66.34	16.75		150.0	
10021- DAC	GSM-FDD (TDMA, GMSK)	X	3.65	69.24	12.37	9.39	50.0	± 9.6 %
		Y	3.67	69.37	12.40		50.0	
		Z	4.11	70.87	13.19		50.0	
10023- DAC	GPRS-FDD (TDMA, GMSK, TN 0)	X	3.62	68.95	12.28	9.57	50.0	± 9.6 %
		Y	3.53	69.01	12.27		50.0	
		Z	3.99	70.28	12.97		50.0	
10024- DAC	GPRS-FDD (TDMA, GMSK, TN 0-1)	X	2.20	67.14	10.46	6.56	60.0	± 9.6 %
		Y	2.17	67.33	10.51		60.0	
		Z	2.59	69.12	11.43		60.0	
10025- DAC	EDGE-FDD (TDMA, 8PSK, TN 0)	X	4.80	71.62	25.40	12.57	50.0	± 9.6 %
		Y	6.74	83.11	31.27		50.0	
		Z	4.57	71.51	25.46		50.0	
10026- DAC	EDGE-FDD (TDMA, 8PSK, TN 0-1)	X	7.74	85.99	29.11	9.56	60.0	± 9.6 %
		Y	7.96	87.71	30.14		60.0	
		Z	7.04	84.41	28.69		60.0	
10027- DAC	GPRS-FDD (TDMA, GMSK, TN 0-1-2)	X	1.67	66.94	9.77	4.80	80.0	± 9.6 %
		Y	1.71	67.56	10.00		80.0	
		Z	2.28	70.14	11.20		80.0	
10028- DAC	GPRS-FDD (TDMA, GMSK, TN 0-1-2-3)	X	1.66	66.75	10.03	3.55	100.0	± 9.6 %
		Y	2.27	71.59	11.01		100.0	
		Z	4.00	76.27	12.74		100.0	
10029- DAC	EDGE-FDD (TDMA, 8PSK, TN 0-1-2)	X	5.02	77.39	24.74	7.60	90.0	± 9.6 %
		Y	4.86	77.49	25.08		80.0	
		Z	4.80	75.91	24.26		80.0	
10030- CAA	IEEE 802.15.1 Bluetooth (GFSK, DH1)	X	1.63	65.62	9.34	5.30	70.0	± 9.6 %
		Y	1.56	65.63	9.29		70.0	
		Z	1.82	67.04	10.07		70.0	
10031- CAA	IEEE 802.15.1 Bluetooth (GFSK, DH3)	X	0.62	64.71	7.40	1.88	100.0	± 9.6 %
		Y	1.14	66.92	8.89		100.0	
		Z	1.45	70.56	9.63		100.0	



EX3DV4- SN:7461

May 26, 2017

10032-CAA	IEEE 802.15.1 Bluetooth (GFSK, DH5)	X	100.00	95.46	14.85	1.17	100.0	± 9.6 %
		Y	100.00	98.47	15.90		100.0	
		Z	100.00	98.48	15.97		100.0	
10033-CAA	IEEE 802.15.1 Bluetooth (PI4-QPSK, DH1)	X	3.62	75.28	17.76	5.30	70.0	± 9.6 %
		Y	3.53	75.17	17.59		70.0	
		Z	3.32	74.05	17.05		70.0	
10034-CAA	IEEE 802.15.1 Bluetooth (PI4-QPSK, DH3)	X	1.84	70.69	15.51	1.86	100.0	± 9.6 %
		Y	1.85	71.09	15.50		100.0	
		Z	1.68	69.47	14.51		100.0	
10035-CAA	IEEE 802.15.1 Bluetooth (PI4-QPSK, DH5)	X	1.56	69.85	15.19	1.17	100.0	± 9.6 %
		Y	1.61	70.62	15.34		100.0	
		Z	1.43	68.71	14.16		100.0	
10036-CAA	IEEE 802.15.1 Bluetooth (8-DPSK, DH1)	X	4.07	77.13	18.54	5.30	70.0	± 9.6 %
		Y	3.98	77.04	18.38		70.0	
		Z	3.69	75.71	17.77		70.0	
10037-CAA	IEEE 802.15.1 Bluetooth (8-DPSK, DH3)	X	1.76	70.24	15.28	1.86	100.0	± 9.6 %
		Y	1.75	70.53	15.23		100.0	
		Z	1.60	68.97	14.26		100.0	
10038-CAA	IEEE 802.15.1 Bluetooth (8-DPSK, DH5)	X	1.59	70.17	15.44	1.17	100.0	± 9.6 %
		Y	1.62	70.97	15.61		100.0	
		Z	1.44	68.97	14.39		100.0	
10039-CAB	CDMA2000 (1xRTT, RC1)	X	2.87	78.58	19.00	0.00	150.0	± 9.6 %
		Y	3.71	82.60	20.20		150.0	
		Z	2.39	76.09	17.40		150.0	
10042-CAB	IS-54 / IS-136 FDD (TDMA/FDM, PI4-QPSK, Halfrate)	X	2.27	66.07	10.11	7.78	50.0	± 9.6 %
		Y	2.25	66.15	10.12		50.0	
		Z	2.49	67.26	10.76		50.0	
10044-CAA	IS-91/EIA/TIA-553 FDD (FDMA, FM)	X	0.00	108.33	3.35	0.00	150.0	± 9.6 %
		Y	0.00	107.17	0.50		150.0	
		Z	0.00	104.36	3.50		150.0	
10048-CAA	DECT (TDD, TDMA/FDM, GFSK, Full Slot, 24)	X	4.18	66.31	12.89	13.80	25.0	± 9.6 %
		Y	4.27	66.33	12.65		25.0	
		Z	4.47	67.13	13.13		25.0	
10049-CAA	DECT (TDD, TDMA/FDM, GFSK, Double Slot, 12)	X	3.94	68.52	12.38	10.79	40.0	± 9.6 %
		Y	3.97	68.53	12.34		40.0	
		Z	4.20	69.41	12.86		40.0	
10056-CAA	UMTS-TDD (TD-SCDMA, 1.28 Mcps)	X	6.52	77.45	18.41	9.03	50.0	± 9.6 %
		Y	6.69	77.82	18.41		50.0	
		Z	6.54	77.56	18.34		50.0	
10058-DAC	EDGE-FDD (TDMA, 8PSK, TN 0-1-2-3)	X	3.95	73.29	22.37	6.55	100.0	± 9.6 %
		Y	3.78	73.00	22.50		100.0	
		Z	3.66	72.04	21.93		100.0	
10059-CAB	IEEE 802.11b WiFi 2.4 GHz (DSSS, 2 Mcps)	X	1.15	64.60	15.72	0.61	110.0	± 9.6 %
		Y	1.16	64.89	16.01		110.0	
		Z	1.14	64.23	15.40		110.0	
10060-CAB	IEEE 802.11b WiFi 2.4 GHz (DSSS, 5.5 Mcps)	X	3.47	87.60	22.22	1.30	110.0	± 9.6 %
		Y	4.98	94.17	24.64		110.0	
		Z	2.37	82.46	20.63		110.0	

Certificate No: EX3-7461\_May17

Page 13 of 38

EX3DV4-- SN-7461

May 26, 2017

10061-CAB	IEEE 802.11b WiFi 2.4 GHz (DSSS, 11 Mbps)	X	1.83	72.83	18.50	2.04	110.0	± 9.6 %
		Y	1.83	73.42	18.96		110.0	
		Z	1.68	71.61	18.01		110.0	
10062-CAB	IEEE 802.11a/h WiFi 5 GHz (OFDM, 6 Mbps)	X	4.70	66.54	16.45	0.49	100.0	± 9.6 %
		Y	4.67	66.64	16.54		100.0	
		Z	4.62	66.55	16.40		100.0	
10063-CAB	IEEE 802.11a/h WiFi 5 GHz (OFDM, 9 Mbps)	X	4.70	66.57	16.49	0.72	100.0	± 9.6 %
		Y	4.66	66.67	16.57		100.0	
		Z	4.62	66.57	16.44		100.0	
10064-CAB	IEEE 802.11a/h WiFi 5 GHz (OFDM, 12 Mbps)	X	5.01	66.84	16.70	0.86	100.0	± 9.6 %
		Y	4.95	66.91	16.77		100.0	
		Z	4.90	66.81	16.64		100.0	
10065-CAB	IEEE 802.11a/h WiFi 5 GHz (OFDM, 18 Mbps)	X	4.84	66.64	16.70	1.21	100.0	± 9.6 %
		Y	4.79	66.70	16.77		100.0	
		Z	4.75	66.61	16.65		100.0	
10066-CAB	IEEE 802.11a/h WiFi 5 GHz (OFDM, 24 Mbps)	X	4.84	66.58	16.80	1.46	100.0	± 9.6 %
		Y	4.79	66.65	16.87		100.0	
		Z	4.75	66.55	16.74		100.0	
10067-CAB	IEEE 802.11a/h WiFi 5 GHz (OFDM, 36 Mbps)	X	5.11	66.60	17.12	2.04	100.0	± 9.6 %
		Y	5.05	66.71	17.21		100.0	
		Z	5.02	66.66	17.10		100.0	
10068-CAB	IEEE 802.11a/h WiFi 5 GHz (OFDM, 48 Mbps)	X	5.15	66.66	17.29	2.55	100.0	± 9.6 %
		Y	5.09	66.71	17.36		100.0	
		Z	5.04	66.62	17.24		100.0	
10069-CAB	IEEE 802.11a/h WiFi 5 GHz (OFDM, 54 Mbps)	X	5.22	66.59	17.44	2.67	100.0	± 9.6 %
		Y	5.16	66.69	17.53		100.0	
		Z	5.12	66.61	17.42		100.0	
10071-CAB	IEEE 802.11g WiFi 2.4 GHz (DSSS/OFDM, 9 Mbps)	X	4.91	66.28	16.98	1.99	100.0	± 9.6 %
		Y	4.87	66.39	17.07		100.0	
		Z	4.84	66.34	16.97		100.0	
10072-CAB	IEEE 802.11g WiFi 2.4 GHz (DSSS/OFDM, 12 Mbps)	X	4.87	66.54	17.12	2.30	100.0	± 9.6 %
		Y	4.83	66.62	17.20		100.0	
		Z	4.80	66.56	17.09		100.0	
10073-CAB	IEEE 802.11g WiFi 2.4 GHz (DSSS/OFDM, 18 Mbps)	X	4.90	66.56	17.32	2.83	100.0	± 9.6 %
		Y	4.86	66.67	17.42		100.0	
		Z	4.83	66.61	17.32		100.0	
10074-CAB	IEEE 802.11g WiFi 2.4 GHz (DSSS/OFDM, 24 Mbps)	X	4.86	66.36	17.41	3.30	100.0	± 9.6 %
		Y	4.82	66.49	17.50		100.0	
		Z	4.80	66.45	17.40		100.0	
10075-CAB	IEEE 802.11g WiFi 2.4 GHz (DSSS/OFDM, 36 Mbps)	X	4.89	66.49	17.67	3.82	90.0	± 9.6 %
		Y	4.85	66.57	17.75		90.0	
		Z	4.83	66.51	17.65		90.0	
10076-CAB	IEEE 802.11g WiFi 2.4 GHz (DSSS/OFDM, 48 Mbps)	X	4.88	66.20	17.72	4.15	90.0	± 9.6 %
		Y	4.85	66.33	17.83		90.0	
		Z	4.84	66.29	17.74		90.0	
10077-CAB	IEEE 802.11g WiFi 2.4 GHz (DSSS/OFDM, 54 Mbps)	X	4.89	66.22	17.78	4.30	90.0	± 9.6 %
		Y	4.87	66.36	17.89		90.0	
		Z	4.86	66.33	17.81		90.0	

EX3DV4- SN:7461

May 26, 2017

10081-CAB	CDMA2000 (1xRTT, RC3)	X	1.10	69.78	15.08	0.00	150.0	± 9.6 %	
		Y	1.25	71.97	15.86			150.0	
		Z	0.94	67.86	13.56			150.0	
10082-CAB	IS-94 / IS-136 FDD (TDMA/FDM, PI/4-DQPSK, Fullrate)	X	6.89	68.16	6.48	4.77	80.0	± 9.6 %	
		Y	9.03	68.75	6.44			80.0	
		Z	2.14	64.48	5.56			80.0	
10090-DAC	GPRS-FDD (TDMA, GMSK, TN 0-4)	X	2.20	67.11	10.46	6.56	60.0	± 9.6 %	
		Y	2.18	67.26	10.50			60.0	
		Z	2.58	69.06	11.42			60.0	
10097-CAB	UMTS-FDD (HSDPA)	X	1.96	68.95	16.65	0.00	150.0	± 9.6 %	
		Y	2.03	69.78	17.08			150.0	
		Z	1.90	68.63	16.26			150.0	
10098-CAB	UMTS-FDD (HSUPA, Subtest 2)	X	1.92	68.92	16.62	0.00	150.0	± 9.6 %	
		Y	1.99	69.76	17.05			150.0	
		Z	1.86	68.58	16.23			150.0	
10099-DAC	EDGE-FDD (TDMA, 8PSK, TN 0-4)	X	7.77	86.05	29.12	9.56	60.0	± 9.6 %	
		Y	8.00	87.79	30.15			60.0	
		Z	7.07	84.48	28.71			60.0	
10100-CAC	LTE-FDD (SC-FDMA, 100% RB, 20 MHz, QPSK)	X	3.41	71.75	17.46	0.00	150.0	± 9.6 %	
		Y	3.44	72.14	17.75			150.0	
		Z	3.23	71.03	17.13			150.0	
10101-CAC	LTE-FDD (SC-FDMA, 100% RB, 20 MHz, 16-QAM)	X	3.37	68.15	16.36	0.00	150.0	± 9.6 %	
		Y	3.36	68.31	16.52			150.0	
		Z	3.27	67.82	16.16			150.0	
10102-CAC	LTE-FDD (SC-FDMA, 100% RB, 20 MHz, 64-QAM)	X	3.47	68.09	16.45	0.00	150.0	± 9.6 %	
		Y	3.46	68.22	16.58			150.0	
		Z	3.37	67.79	16.26			150.0	
10103-CAC	LTE-TDD (SC-FDMA, 100% RB, 20 MHz, QPSK)	X	5.32	72.31	18.48	3.98	65.0	± 9.6 %	
		Y	5.38	72.93	18.87			65.0	
		Z	5.19	72.32	18.58			65.0	
10104-CAC	LTE-TDD (SC-FDMA, 100% RB, 20 MHz, 16-QAM)	X	5.66	71.49	19.00	3.98	65.0	± 9.6 %	
		Y	5.50	71.39	19.07			65.0	
		Z	5.43	71.12	18.88			65.0	
10105-CAC	LTE-TDD (SC-FDMA, 100% RB, 20 MHz, 64-QAM)	X	5.38	70.43	18.85	3.98	65.0	± 9.6 %	
		Y	5.45	71.05	19.24			65.0	
		Z	5.25	70.30	18.82			65.0	
10108-CAD	LTE-FDD (SC-FDMA, 100% RB, 10 MHz, QPSK)	X	2.98	70.93	17.30	0.00	150.0	± 9.6 %	
		Y	3.00	71.37	17.61			150.0	
		Z	2.81	70.27	16.97			150.0	
10109-CAD	LTE-FDD (SC-FDMA, 100% RB, 10 MHz, 16-QAM)	X	3.04	68.08	16.35	0.00	150.0	± 9.6 %	
		Y	3.03	68.30	16.52			150.0	
		Z	2.93	67.76	16.11			150.0	
10110-CAD	LTE-FDD (SC-FDMA, 100% RB, 5 MHz, QPSK)	X	2.43	70.02	16.99	0.00	150.0	± 9.6 %	
		Y	2.45	70.63	17.36			150.0	
		Z	2.28	69.43	16.61			150.0	
10111-CAD	LTE-FDD (SC-FDMA, 100% RB, 5 MHz, 16-QAM)	X	2.80	69.19	16.89	0.00	150.0	± 9.6 %	
		Y	2.81	69.62	17.09			150.0	
		Z	2.69	68.96	16.59			150.0	

EX3DV4- SN:7461

May 26, 2017

10112-CAD	LTE-FDD (SC-FDMA, 100% RB, 10 MHz, 64-QAM)	X	3.16	68.01	16.36	0.00	150.0	± 9.6 %
		Y	3.15	68.22	16.54		150.0	
		Z	3.08	67.75	16.17		150.0	
10113-CAD	LTE-FDD (SC-FDMA, 100% RB, 5 MHz, 64-QAM)	X	2.96	69.26	16.98	0.00	150.0	± 9.6 %
		Y	2.96	69.67	17.17		150.0	
		Z	2.85	69.09	16.71		150.0	
10114-CAB	IEEE 802.11n (HT Greenfield, 13.5 Mbps, BPSK)	X	5.20	67.33	16.58	0.00	150.0	± 9.6 %
		Y	5.18	67.44	16.69		150.0	
		Z	5.13	67.32	16.55		150.0	
10115-CAB	IEEE 802.11n (HT Greenfield, 81 Mbps, 16-QAM)	X	5.55	67.60	16.71	0.00	150.0	± 9.6 %
		Y	5.48	67.58	16.76		150.0	
		Z	5.41	67.42	16.60		150.0	
10116-CAB	IEEE 802.11n (HT Greenfield, 135 Mbps, 64-QAM)	X	5.32	67.58	16.63	0.00	150.0	± 9.6 %
		Y	5.29	67.66	16.72		150.0	
		Z	5.23	67.50	16.57		150.0	
10117-CAB	IEEE 802.11n (HT Mixed, 13.5 Mbps, BPSK)	X	5.18	67.28	16.57	0.00	150.0	± 9.6 %
		Y	5.15	67.31	16.64		150.0	
		Z	5.10	67.17	16.49		150.0	
10118-CAB	IEEE 802.11n (HT Mixed, 81 Mbps, 16-QAM)	X	5.62	67.77	16.80	0.00	150.0	± 9.6 %
		Y	5.57	67.79	16.87		150.0	
		Z	5.50	67.62	16.71		150.0	
10119-CAB	IEEE 802.11n (HT Mixed, 135 Mbps, 64-QAM)	X	5.29	67.51	16.61	0.00	150.0	± 9.6 %
		Y	5.26	67.59	16.70		150.0	
		Z	5.21	67.45	16.55		150.0	
10140-CAC	LTE-FDD (SC-FDMA, 100% RB, 15 MHz, 16-QAM)	X	3.52	68.08	16.36	0.00	150.0	± 9.6 %
		Y	3.50	68.22	16.49		150.0	
		Z	3.41	67.79	16.17		150.0	
10141-CAC	LTE-FDD (SC-FDMA, 100% RB, 15 MHz, 64-QAM)	X	3.64	68.14	16.51	0.00	150.0	± 9.6 %
		Y	3.62	68.29	16.65		150.0	
		Z	3.53	67.90	16.34		150.0	
10142-CAD	LTE-FDD (SC-FDMA, 100% RB, 3 MHz, QPSK)	X	2.24	70.31	16.90	0.00	150.0	± 9.6 %
		Y	2.28	71.14	17.30		150.0	
		Z	2.09	69.67	16.38		150.0	
10143-CAD	LTE-FDD (SC-FDMA, 100% RB, 3 MHz, 16-QAM)	X	2.75	70.44	16.98	0.00	150.0	± 9.6 %
		Y	2.79	71.11	17.17		150.0	
		Z	2.61	70.11	16.46		150.0	
10144-CAD	LTE-FDD (SC-FDMA, 100% RB, 3 MHz, 64-QAM)	X	2.44	67.84	15.12	0.00	150.0	± 9.6 %
		Y	2.43	68.04	15.20		150.0	
		Z	2.29	67.17	14.53		150.0	
10145-CAD	LTE-FDD (SC-FDMA, 100% RB, 1.4 MHz, QPSK)	X	1.59	68.59	14.29	0.00	150.0	± 9.6 %
		Y	1.56	68.68	13.97		150.0	
		Z	1.29	66.12	12.32		150.0	
10146-CAD	LTE-FDD (SC-FDMA, 100% RB, 1.4 MHz, 16-QAM)	X	2.27	67.78	12.66	0.00	150.0	± 9.6 %
		Y	1.69	65.02	10.94		150.0	
		Z	1.70	64.69	10.36		150.0	
10147-CAD	LTE-FDD (SC-FDMA, 100% RB, 1.4 MHz, 64-QAM)	X	2.80	70.44	14.00	0.00	150.0	± 9.6 %
		Y	1.94	66.67	11.90		150.0	
		Z	1.93	66.12	11.19		150.0	

Certificate No: EX3-7461\_May17

Page 16 of 38

EX3DV4- SN.7461

May 26, 2017

10149-CAC	LTE-FDD (SC-FDMA, 50% RB, 20 MHz, 16-QAM)	X	3.05	68.15	16.40	0.00	150.0	± 9.6 %
		Y	3.04	68.37	16.57		150.0	
		Z	2.94	67.83	16.17		150.0	
10150-CAC	LTE-FDD (SC-FDMA, 50% RB, 20 MHz, 64-QAM)	X	3.17	68.07	16.43	0.00	150.0	± 9.6 %
		Y	3.16	68.29	16.58		150.0	
		Z	3.06	67.81	16.21		150.0	
10151-CAC	LTE-TDD (SC-FDMA, 50% RB, 20 MHz, QPSK)	X	5.41	73.98	19.25	3.98	65.0	± 9.6 %
		Y	5.30	74.18	19.45		65.0	
		Z	5.20	73.82	19.25		65.0	
10152-CAC	LTE-TDD (SC-FDMA, 50% RB, 20 MHz, 16-QAM)	X	5.15	71.15	18.59	3.98	65.0	± 9.6 %
		Y	5.01	71.09	18.63		65.0	
		Z	4.92	70.76	18.39		65.0	
10153-CAC	LTE-TDD (SC-FDMA, 50% RB, 20 MHz, 64-QAM)	X	5.48	72.04	19.37	3.98	65.0	± 9.6 %
		Y	5.33	71.98	19.41		65.0	
		Z	5.26	71.73	19.21		65.0	
10154-CAD	LTE-FDD (SC-FDMA, 50% RB, 10 MHz, QPSK)	X	2.52	70.66	17.36	0.00	150.0	± 9.6 %
		Y	2.53	71.21	17.69		150.0	
		Z	2.35	69.97	16.93		150.0	
10155-CAD	LTE-FDD (SC-FDMA, 50% RB, 10 MHz, 16-QAM)	X	2.80	69.19	16.90	0.00	150.0	± 9.6 %
		Y	2.81	69.63	17.11		150.0	
		Z	2.69	68.97	16.61		150.0	
10156-CAD	LTE-FDD (SC-FDMA, 50% RB, 5 MHz, QPSK)	X	2.13	70.86	16.88	0.00	150.0	± 9.6 %
		Y	2.18	71.83	17.39		150.0	
		Z	1.95	70.01	16.28		150.0	
10157-CAD	LTE-FDD (SC-FDMA, 50% RB, 5 MHz, 16-QAM)	X	2.33	68.87	15.44	0.00	150.0	± 9.6 %
		Y	2.34	69.22	15.55		150.0	
		Z	2.16	68.01	14.69		150.0	
10158-CAD	LTE-FDD (SC-FDMA, 50% RB, 10 MHz, 64-QAM)	X	2.96	69.33	17.03	0.00	150.0	± 9.6 %
		Y	2.96	69.75	17.23		150.0	
		Z	2.85	69.17	16.77		150.0	
10159-CAD	LTE-FDD (SC-FDMA, 50% RB, 5 MHz, 64-QAM)	X	2.48	69.32	15.82	0.00	150.0	± 9.6 %
		Y	2.49	69.85	15.91		150.0	
		Z	2.29	68.61	15.04		150.0	
10160-CAC	LTE-FDD (SC-FDMA, 50% RB, 15 MHz, QPSK)	X	2.91	69.55	16.91	0.00	150.0	± 9.6 %
		Y	2.93	70.01	17.21		150.0	
		Z	2.80	69.21	16.69		150.0	
10161-CAC	LTE-FDD (SC-FDMA, 50% RB, 15 MHz, 16-QAM)	X	3.07	68.03	16.39	0.00	150.0	± 9.6 %
		Y	3.06	68.28	16.55		150.0	
		Z	2.96	67.79	16.16		150.0	
10162-CAC	LTE-FDD (SC-FDMA, 50% RB, 15 MHz, 64-QAM)	X	3.18	68.11	16.47	0.00	150.0	± 9.6 %
		Y	3.17	68.39	16.64		150.0	
		Z	3.07	67.94	16.27		150.0	
10166-CAD	LTE-FDD (SC-FDMA, 50% RB, 1.4 MHz, QPSK)	X	3.87	69.75	19.07	3.01	150.0	± 9.6 %
		Y	3.39	68.85	18.73		150.0	
		Z	3.52	69.82	19.00		150.0	
10167-CAD	LTE-FDD (SC-FDMA, 50% RB, 1.4 MHz, 16-QAM)	X	4.71	73.34	19.78	3.01	150.0	± 9.6 %
		Y	4.04	71.50	19.11		150.0	
		Z	4.46	73.20	19.68		150.0	

Certificate No: EX3-7461\_May17

Page 17 of 38

EX3DV4- SN:7461

May 26, 2017

10168-CAD	LTE-FDD (SC-FDMA, 50% RB, 1.4 MHz, 64-QAM)	X	5.39	76.17	21.36	3.01	150.0	± 9.6 %
		Y	4.51	73.86	20.52		150.0	
		Z	5.18	76.27	21.38		150.0	
10169-CAC	LTE-FDD (SC-FDMA, 1 RB, 20 MHz, QPSK)	X	3.16	70.45	19.38	3.01	150.0	± 9.6 %
		Y	2.88	67.98	18.40		150.0	
		Z	2.93	69.45	18.94		150.0	
10170-CAC	LTE-FDD (SC-FDMA, 1 RB, 20 MHz, 16-QAM)	X	5.21	79.73	22.91	3.01	150.0	± 9.6 %
		Y	3.56	73.96	20.83		150.0	
		Z	4.59	78.10	22.32		150.0	
10171-AAC	LTE-FDD (SC-FDMA, 1 RB, 20 MHz, 64-QAM)	X	3.78	73.10	19.13	3.01	150.0	± 9.6 %
		Y	2.89	69.55	17.87		150.0	
		Z	3.41	71.93	18.65		150.0	
10172-CAC	LTE-TDD (SC-FDMA, 1 RB, 20 MHz, QPSK)	X	5.49	81.31	23.38	6.02	65.0	± 9.6 %
		Y	3.72	75.58	21.46		65.0	
		Z	4.76	80.03	23.16		65.0	
10173-CAC	LTE-TDD (SC-FDMA, 1 RB, 20 MHz, 16-QAM)	X	6.57	85.29	22.74	6.02	65.0	± 9.6 %
		Y	5.82	80.71	21.44		65.0	
		Z	7.29	84.12	22.55		65.0	
10174-CAC	LTE-TDD (SC-FDMA, 1 RB, 20 MHz, 64-QAM)	X	6.27	79.56	20.24	6.02	65.0	± 9.6 %
		Y	5.18	77.97	19.88		65.0	
		Z	5.99	79.13	20.26		65.0	
10175-CAD	LTE-FDD (SC-FDMA, 1 RB, 10 MHz, QPSK)	X	3.10	70.01	19.07	3.01	150.0	± 9.6 %
		Y	2.65	67.68	18.14		150.0	
		Z	2.88	69.06	18.65		150.0	
10176-CAD	LTE-FDD (SC-FDMA, 1 RB, 10 MHz, 16-QAM)	X	5.22	79.77	22.92	3.01	150.0	± 9.6 %
		Y	3.56	73.89	20.85		150.0	
		Z	4.60	78.13	22.34		150.0	
10177-CAF	LTE-FDD (SC-FDMA, 1 RB, 5 MHz, QPSK)	X	3.14	70.23	19.20	3.01	150.0	± 9.6 %
		Y	2.67	67.83	18.24		150.0	
		Z	2.91	69.25	18.76		150.0	
10178-CAD	LTE-FDD (SC-FDMA, 1 RB, 5 MHz, 16-QAM)	X	5.10	79.30	22.71	3.01	150.0	± 9.6 %
		Y	3.52	73.64	20.71		150.0	
		Z	4.52	77.78	22.17		150.0	
10179-CAD	LTE-FDD (SC-FDMA, 1 RB, 10 MHz, 64-QAM)	X	4.37	76.02	20.77	3.01	150.0	± 9.6 %
		Y	3.19	71.56	19.20		150.0	
		Z	3.91	74.88	20.27		150.0	
10180-CAD	LTE-FDD (SC-FDMA, 1 RB, 5 MHz, 64-QAM)	X	3.76	72.96	19.05	3.01	150.0	± 9.6 %
		Y	2.88	69.47	17.81		150.0	
		Z	3.39	71.83	18.59		150.0	
10181-CAC	LTE-FDD (SC-FDMA, 1 RB, 15 MHz, QPSK)	X	3.13	70.21	19.19	3.01	150.0	± 9.6 %
		Y	2.67	67.81	18.23		150.0	
		Z	2.91	69.23	18.75		150.0	
10182-CAC	LTE-FDD (SC-FDMA, 1 RB, 15 MHz, 16-QAM)	X	5.09	79.27	22.69	3.01	150.0	± 9.6 %
		Y	3.52	73.62	20.70		150.0	
		Z	4.51	77.74	22.15		150.0	
10183-AAB	LTE-FDD (SC-FDMA, 1 RB, 15 MHz, 64-QAM)	X	3.75	72.94	19.04	3.01	150.0	± 9.6 %
		Y	2.88	69.45	17.80		150.0	
		Z	3.39	71.80	18.58		150.0	

Certificate No: EX3-7461\_May17

Page 18 of 38

EX3DV4- SN:7461

May 26, 2017

10184-CAD	LTE-FDD (SC-FDMA, 1 RB, 3 MHz, QPSK)	X	3.14	70.26	19.22	3.01	150.0	± 9.6 %
		Y	2.68	67.86	18.26		150.0	
		Z	2.92	69.28	18.78		150.0	
10185-CAD	LTE-FDD (SC-FDMA, 1 RB, 3 MHz, 16-QAM)	X	5.12	79.38	22.74	3.01	150.0	± 9.6 %
		Y	3.54	73.69	20.74		150.0	
		Z	4.54	77.85	22.20		150.0	
10186-AAD	LTE-FDD (SC-FDMA, 1 RB, 3 MHz, 64-QAM)	X	3.78	73.02	19.08	3.01	150.0	± 9.6 %
		Y	2.89	69.52	17.84		150.0	
		Z	3.41	71.89	18.62		150.0	
10187-CAD	LTE-FDD (SC-FDMA, 1 RB, 1.4 MHz, QPSK)	X	3.15	70.31	19.28	3.01	150.0	± 9.6 %
		Y	2.69	67.91	18.32		150.0	
		Z	2.93	69.35	18.85		150.0	
10188-CAD	LTE-FDD (SC-FDMA, 1 RB, 1.4 MHz, 16-QAM)	X	5.44	80.59	23.33	3.01	150.0	± 9.6 %
		Y	3.66	74.42	21.16		150.0	
		Z	4.78	78.91	22.74		150.0	
10189-AAD	LTE-FDD (SC-FDMA, 1 RB, 1.4 MHz, 64-QAM)	X	3.90	73.66	19.45	3.01	150.0	± 9.6 %
		Y	2.96	69.95	18.13		150.0	
		Z	3.51	72.48	18.97		150.0	
10193-CAB	IEEE 802.11n (HT Greenfield, 6.5 Mbps, BPSK)	X	4.61	66.78	16.35	0.00	150.0	± 9.6 %
		Y	4.58	66.89	16.43		150.0	
		Z	4.53	66.76	16.26		150.0	
10194-CAB	IEEE 802.11n (HT Greenfield, 39 Mbps, 16-QAM)	X	4.80	67.12	16.47	0.00	150.0	± 9.6 %
		Y	4.76	67.21	16.55		150.0	
		Z	4.70	67.07	16.39		150.0	
10195-CAB	IEEE 802.11n (HT Greenfield, 65 Mbps, 64-QAM)	X	4.84	67.14	16.48	0.00	150.0	± 9.6 %
		Y	4.80	67.23	16.56		150.0	
		Z	4.74	67.10	16.40		150.0	
10196-CAB	IEEE 802.11n (HT Mixed, 6.5 Mbps, BPSK)	X	4.63	66.88	16.38	0.00	150.0	± 9.6 %
		Y	4.59	66.96	16.45		150.0	
		Z	4.53	66.82	16.28		150.0	
10197-CAB	IEEE 802.11n (HT Mixed, 39 Mbps, 16-QAM)	X	4.61	67.14	16.48	0.00	150.0	± 9.6 %
		Y	4.77	67.23	16.56		150.0	
		Z	4.71	67.09	16.40		150.0	
10198-CAB	IEEE 802.11n (HT Mixed, 65 Mbps, 64-QAM)	X	4.84	67.16	16.49	0.00	150.0	± 9.6 %
		Y	4.80	67.25	16.58		150.0	
		Z	4.74	67.11	16.41		150.0	
10219-CAB	IEEE 802.11n (HT Mixed, 7.2 Mbps, BPSK)	X	4.58	66.88	16.35	0.00	150.0	± 9.6 %
		Y	4.54	66.98	16.42		150.0	
		Z	4.48	66.84	16.25		150.0	
10220-CAB	IEEE 802.11n (HT Mixed, 43.3 Mbps, 16-QAM)	X	4.81	67.12	16.47	0.00	150.0	± 9.6 %
		Y	4.76	67.20	16.55		150.0	
		Z	4.70	67.05	16.39		150.0	
10221-CAB	IEEE 802.11n (HT Mixed, 72.2 Mbps, 64-QAM)	X	4.85	67.08	16.47	0.00	150.0	± 9.6 %
		Y	4.81	67.17	16.56		150.0	
		Z	4.75	67.04	16.40		150.0	
10222-CAB	IEEE 802.11n (HT Mixed, 15 Mbps, BPSK)	X	5.18	67.30	16.57	0.00	150.0	± 9.6 %
		Y	5.13	67.32	16.64		150.0	
		Z	5.07	67.18	16.49		150.0	

EX3DV4- SN:7461

May 26, 2017

10223-CAB	IEEE 802.11n (HT Mixed, 90 Mbps, 16-QAM)	X	5.48	67.48	16.67	0.00	150.0	± 9.6 %
		Y	5.43	67.50	16.74		150.0	
		Z	5.37	67.37	16.60		150.0	
10224-CAB	IEEE 802.11n (HT Mixed, 150 Mbps, 64-QAM)	X	5.21	67.40	16.55	0.00	150.0	± 9.6 %
		Y	5.17	67.44	16.62		150.0	
		Z	5.12	67.30	16.47		150.0	
10225-CAB	UMTS-FDD (HSPA+)	X	2.91	66.58	15.82	0.00	150.0	± 9.6 %
		Y	2.89	66.83	15.91		150.0	
		Z	2.82	66.47	15.55		150.0	
10226-CAA	LTE-TDD (SC-FDMA, 1 RB, 1.4 MHz, 16-QAM)	X	9.18	86.49	23.24	6.02	65.0	± 9.6 %
		Y	6.13	81.60	21.86		65.0	
		Z	7.79	85.28	23.05		65.0	
10227-CAA	LTE-TDD (SC-FDMA, 1 RB, 1.4 MHz, 64-QAM)	X	7.96	83.03	21.47	6.02	65.0	± 9.6 %
		Y	5.69	79.29	20.40		65.0	
		Z	7.11	82.56	21.48		65.0	
10228-CAA	LTE-TDD (SC-FDMA, 1 RB, 1.4 MHz, QPSK)	X	6.48	84.41	24.57	6.02	65.0	± 9.6 %
		Y	5.03	81.10	23.62		65.0	
		Z	5.36	82.20	24.02		65.0	
10229-CAB	LTE-TDD (SC-FDMA, 1 RB, 3 MHz, 16-QAM)	X	8.65	85.41	22.79	6.02	65.0	± 9.6 %
		Y	5.87	80.80	21.48		65.0	
		Z	7.36	84.23	22.60		65.0	
10230-CAB	LTE-TDD (SC-FDMA, 1 RB, 3 MHz, 64-QAM)	X	7.55	82.11	21.07	6.02	65.0	± 9.6 %
		Y	5.44	78.57	20.05		65.0	
		Z	6.71	81.64	21.07		65.0	
10231-CAB	LTE-TDD (SC-FDMA, 1 RB, 3 MHz, QPSK)	X	6.21	83.56	24.18	6.02	65.0	± 9.6 %
		Y	4.86	80.42	23.28		65.0	
		Z	5.15	81.42	23.64		65.0	
10232-CAC	LTE-TDD (SC-FDMA, 1 RB, 5 MHz, 16-QAM)	X	8.63	85.38	22.78	6.02	65.0	± 9.6 %
		Y	5.86	80.78	21.47		65.0	
		Z	7.34	84.21	22.59		65.0	
10233-CAC	LTE-TDD (SC-FDMA, 1 RB, 5 MHz, 64-QAM)	X	7.53	82.09	21.07	6.02	65.0	± 9.6 %
		Y	5.43	78.55	20.05		65.0	
		Z	6.70	81.62	21.06		65.0	
10234-CAC	LTE-TDD (SC-FDMA, 1 RB, 5 MHz, QPSK)	X	5.97	82.76	23.78	6.02	65.0	± 9.6 %
		Y	4.71	79.77	22.91		65.0	
		Z	4.97	80.89	23.25		65.0	
10235-CAC	LTE-TDD (SC-FDMA, 1 RB, 10 MHz, 16-QAM)	X	8.63	85.40	22.78	6.02	65.0	± 9.6 %
		Y	5.86	80.80	21.48		65.0	
		Z	7.34	84.23	22.60		65.0	
10236-CAC	LTE-TDD (SC-FDMA, 1 RB, 10 MHz, 64-QAM)	X	7.60	82.19	21.10	6.02	65.0	± 9.6 %
		Y	5.47	78.65	20.08		65.0	
		Z	6.76	81.72	21.09		65.0	
10237-CAC	LTE-TDD (SC-FDMA, 1 RB, 10 MHz, QPSK)	X	6.21	83.61	24.19	6.02	65.0	± 9.6 %
		Y	4.86	80.45	23.29		65.0	
		Z	5.15	81.45	23.65		65.0	
10238-CAC	LTE-TDD (SC-FDMA, 1 RB, 15 MHz, 16-QAM)	X	8.60	85.35	22.76	6.02	65.0	± 9.6 %
		Y	5.84	80.75	21.46		65.0	
		Z	7.32	84.18	22.57		65.0	

Certificate No: EX3-7461\_May17

Page 20 of 38



EX3DV4- SN:7461

May 26, 2017

10239-CAC	LTE-TDD (SC-FDMA, 1 RB, 15 MHz, 64-QAM)	X	7.51	82.07	21.06	6.02	65.0	± 9.6 %
		Y	5.41	78.52	20.04		65.0	
		Z	6.67	81.59	21.05		65.0	
10240-CAC	LTE-TDD (SC-FDMA, 1 RB, 15 MHz, QPSK)	X	6.19	83.57	24.17	6.02	65.0	± 9.6 %
		Y	4.84	80.41	23.27		65.0	
		Z	5.13	81.41	23.64		65.0	
10241-CAA	LTE-TDD (SC-FDMA, 50% RB, 1.4 MHz, 16-QAM)	X	6.98	77.29	23.04	6.98	65.0	± 9.6 %
		Y	6.30	76.08	22.60		65.0	
		Z	6.71	77.40	23.08		65.0	
10242-CAA	LTE-TDD (SC-FDMA, 50% RB, 1.4 MHz, 64-QAM)	X	6.40	75.54	22.22	6.98	65.0	± 9.6 %
		Y	5.51	73.37	21.34		65.0	
		Z	6.22	75.94	22.40		65.0	
10243-CAA	LTE-TDD (SC-FDMA, 50% RB, 1.4 MHz, QPSK)	X	5.25	72.46	21.72	6.98	65.0	± 9.6 %
		Y	5.20	73.08	22.11		65.0	
		Z	5.14	72.85	21.93		65.0	
10244-CAB	LTE-TDD (SC-FDMA, 50% RB, 3 MHz, 16-QAM)	X	4.38	70.63	15.81	3.98	65.0	± 9.6 %
		Y	3.77	68.90	14.73		65.0	
		Z	3.89	69.20	14.68		65.0	
10245-CAB	LTE-TDD (SC-FDMA, 50% RB, 3 MHz, 64-QAM)	X	4.37	70.36	15.65	3.98	65.0	± 9.6 %
		Y	3.76	68.62	14.55		65.0	
		Z	3.86	68.87	14.48		65.0	
10246-CAB	LTE-TDD (SC-FDMA, 50% RB, 3 MHz, QPSK)	X	3.88	72.34	16.95	3.98	65.0	± 9.6 %
		Y	3.63	71.80	16.53		65.0	
		Z	3.45	71.00	16.01		65.0	
10247-CAC	LTE-TDD (SC-FDMA, 50% RB, 5 MHz, 16-QAM)	X	4.18	70.49	16.88	3.98	65.0	± 9.6 %
		Y	3.97	70.10	16.53		65.0	
		Z	3.87	69.66	16.15		65.0	
10248-CAC	LTE-TDD (SC-FDMA, 50% RB, 5 MHz, 64-QAM)	X	4.25	70.25	16.76	3.98	65.0	± 9.6 %
		Y	4.03	69.84	16.40		65.0	
		Z	3.93	69.38	16.01		65.0	
10249-CAC	LTE-TDD (SC-FDMA, 50% RB, 5 MHz, QPSK)	X	4.62	74.81	18.77	3.98	65.0	± 9.6 %
		Y	4.48	74.84	18.73		65.0	
		Z	4.28	74.09	18.28		65.0	
10250-CAC	LTE-TDD (SC-FDMA, 50% RB, 10 MHz, 16-QAM)	X	4.99	72.74	19.33	3.98	65.0	± 9.6 %
		Y	4.84	72.66	19.30		65.0	
		Z	4.75	72.36	19.05		65.0	
10251-CAC	LTE-TDD (SC-FDMA, 50% RB, 10 MHz, 64-QAM)	X	4.90	71.18	18.31	3.98	65.0	± 9.6 %
		Y	4.74	71.12	18.28		65.0	
		Z	4.65	70.77	17.99		65.0	
10252-CAC	LTE-TDD (SC-FDMA, 50% RB, 10 MHz, QPSK)	X	5.15	75.36	19.82	3.98	65.0	± 9.6 %
		Y	5.06	75.68	20.02		65.0	
		Z	4.91	75.11	19.71		65.0	
10253-CAC	LTE-TDD (SC-FDMA, 50% RB, 15 MHz, 16-QAM)	X	5.05	70.68	18.39	3.98	65.0	± 9.6 %
		Y	4.92	70.63	18.42		65.0	
		Z	4.85	70.35	18.18		65.0	
10254-CAC	LTE-TDD (SC-FDMA, 50% RB, 15 MHz, 64-QAM)	X	5.36	71.50	19.10	3.98	65.0	± 9.6 %
		Y	5.22	71.48	19.12		65.0	
		Z	5.16	71.23	18.92		65.0	

Certificate No: EX3-7461\_May17

Page 21 of 38

EX3DV4-SN:7461

May 26, 2017

10255-CAC	LTE-TDD (SC-FDMA, 50% RB, 15 MHz, QPSK)	X	5.20	73.47	19.28	3.98	65.0	± 9.6 %
		Y	5.10	73.67	19.47		65.0	
		Z	5.01	73.32	19.25		65.0	
10256-CAA	LTE-TDD (SC-FDMA, 100% RB, 1.4 MHz, 16-QAM)	X	3.49	67.58	13.41	3.98	65.0	± 9.6 %
		Y	2.96	65.82	12.18		65.0	
		Z	3.00	65.87	12.01		65.0	
10257-CAA	LTE-TDD (SC-FDMA, 100% RB, 1.4 MHz, 64-QAM)	X	3.49	67.28	13.20	3.98	65.0	± 9.6 %
		Y	2.96	65.53	11.96		65.0	
		Z	2.99	65.55	11.77		65.0	
10258-CAA	LTE-TDD (SC-FDMA, 100% RB, 1.4 MHz, QPSK)	X	3.12	69.21	14.81	3.98	65.0	± 9.6 %
		Y	2.81	68.11	14.01		65.0	
		Z	2.68	67.39	13.47		65.0	
10259-CAB	LTE-TDD (SC-FDMA, 100% RB, 3 MHz, 16-QAM)	X	4.50	71.33	17.77	3.98	65.0	± 9.6 %
		Y	4.31	71.09	17.55		65.0	
		Z	4.22	70.69	17.22		65.0	
10260-CAB	LTE-TDD (SC-FDMA, 100% RB, 3 MHz, 64-QAM)	X	4.57	71.23	17.74	3.98	65.0	± 9.6 %
		Y	4.37	70.96	17.50		65.0	
		Z	4.28	70.57	17.17		65.0	
10261-CAB	LTE-TDD (SC-FDMA, 100% RB, 3 MHz, QPSK)	X	4.87	74.48	19.01	3.98	65.0	± 9.6 %
		Y	4.55	74.61	19.06		65.0	
		Z	4.38	73.96	18.66		65.0	
10262-CAC	LTE-TDD (SC-FDMA, 100% RB, 5 MHz, 16-QAM)	X	4.99	72.70	19.29	3.98	65.0	± 9.6 %
		Y	4.83	72.61	19.26		65.0	
		Z	4.75	72.31	19.01		65.0	
10263-CAC	LTE-TDD (SC-FDMA, 100% RB, 5 MHz, 64-QAM)	X	4.89	71.17	18.31	3.98	65.0	± 9.6 %
		Y	4.73	71.10	18.27		65.0	
		Z	4.64	70.75	17.99		65.0	
10264-CAC	LTE-TDD (SC-FDMA, 100% RB, 5 MHz, QPSK)	X	5.12	75.22	19.74	3.98	65.0	± 9.6 %
		Y	5.02	75.51	19.93		65.0	
		Z	4.87	74.95	19.62		65.0	
10265-CAC	LTE-TDD (SC-FDMA, 100% RB, 10 MHz, 16-QAM)	X	5.15	71.15	18.59	3.98	65.0	± 9.6 %
		Y	5.00	71.09	18.64		65.0	
		Z	4.92	70.77	18.40		65.0	
10266-CAC	LTE-TDD (SC-FDMA, 100% RB, 10 MHz, 64-QAM)	X	5.48	72.03	19.36	3.98	65.0	± 9.6 %
		Y	5.33	71.97	19.40		65.0	
		Z	5.26	71.71	19.20		65.0	
10267-CAC	LTE-TDD (SC-FDMA, 100% RB, 10 MHz, QPSK)	X	5.40	73.95	19.24	3.98	65.0	± 9.6 %
		Y	5.30	74.15	19.44		65.0	
		Z	5.19	73.79	19.24		65.0	
10268-CAC	LTE-TDD (SC-FDMA, 100% RB, 15 MHz, 16-QAM)	X	5.83	71.41	19.11	3.98	65.0	± 9.6 %
		Y	5.67	71.33	19.17		65.0	
		Z	5.61	71.10	18.99		65.0	
10269-CAC	LTE-TDD (SC-FDMA, 100% RB, 15 MHz, 64-QAM)	X	5.92	71.08	19.04	3.98	65.0	± 9.6 %
		Y	5.68	71.00	19.09		65.0	
		Z	5.62	70.80	18.92		65.0	
10270-CAC	LTE-TDD (SC-FDMA, 100% RB, 15 MHz, QPSK)	X	5.61	72.49	18.80	3.98	65.0	± 9.6 %
		Y	5.49	72.55	18.94		65.0	
		Z	5.43	72.34	18.81		65.0	

Certificate No: EX3-7461\_May17

Page 22 of 38

EX3DV4- SN:7461

May 26, 2017

10274-CAB	UMTS-FDD (HSUPA, Subtest 5, 3GPP Rel8.10)	X	2.68	66.96	15.75	0.00	150.0	± 9.6 %
		Y	2.69	67.37	15.93		150.0	
		Z	2.62	66.91	15.51		150.0	
10275-CAB	UMTS-FDD (HSUPA, Subtest 5, 3GPP Rel8.4)	X	1.78	69.61	16.67	0.00	150.0	± 9.6 %
		Y	1.84	70.57	17.20		150.0	
		Z	1.68	68.89	16.16		150.0	
10277-CAA	PHS (QPSK)	X	2.22	61.21	6.89	9.03	50.0	± 9.6 %
		Y	2.14	60.96	6.56		50.0	
		Z	2.11	60.84	6.46		50.0	
10278-CAA	PHS (QPSK, BW 884MHz, Rolloff 0.5)	X	3.70	67.98	12.97	9.03	50.0	± 9.6 %
		Y	3.44	66.96	12.21		50.0	
		Z	3.38	66.70	12.05		50.0	
10279-CAA	PHS (QPSK, BW 884MHz, Rolloff 0.38)	X	3.81	68.26	13.15	9.03	50.0	± 9.6 %
		Y	3.54	67.22	12.39		50.0	
		Z	3.47	66.94	12.22		50.0	
10290-AAB	CDMA2000, RC1, SC55, Full Rate	X	1.97	72.95	16.47	0.00	150.0	± 9.6 %
		Y	2.21	75.00	17.08		150.0	
		Z	1.64	70.80	14.94		150.0	
10291-AAB	CDMA2000, RC3, SC55, Full Rate	X	1.07	69.38	14.88	0.00	150.0	± 9.6 %
		Y	1.20	71.46	15.62		150.0	
		Z	0.91	67.54	13.39		150.0	
10292-AAB	CDMA2000, RC3, SC32, Full Rate	X	1.84	78.38	19.11	0.00	150.0	± 9.6 %
		Y	2.95	85.56	21.44		150.0	
		Z	1.49	75.28	17.20		150.0	
10293-AAB	CDMA2000, RC3, SC3, Full Rate	X	5.33	95.06	25.27	0.00	150.0	± 9.6 %
		Y	23.01	117.07	30.91		150.0	
		Z	4.56	91.65	23.40		150.0	
10295-AAB	CDMA2000, RC1, SC3, 1/8th Rate 25 fr.	X	5.87	75.61	19.33	9.03	50.0	± 9.6 %
		Y	6.31	76.66	19.49		50.0	
		Z	6.27	76.41	19.27		50.0	
10297-AAB	LTE-FDD (SC-FDMA, 50% RB, 20 MHz, QPSK)	X	3.00	71.06	17.38	0.00	150.0	± 9.6 %
		Y	3.02	71.50	17.69		150.0	
		Z	2.83	70.40	17.05		150.0	
10298-AAC	LTE-FDD (SC-FDMA, 50% RB, 3 MHz, QPSK)	X	1.93	70.82	16.08	0.00	150.0	± 9.6 %
		Y	1.98	71.51	16.27		150.0	
		Z	1.67	69.03	14.79		150.0	
10299-AAC	LTE-FDD (SC-FDMA, 50% RB, 3 MHz, 16-QAM)	X	2.98	70.86	14.96	0.00	150.0	± 9.6 %
		Y	2.32	68.36	13.59		150.0	
		Z	2.44	68.56	13.28		150.0	
10300-AAC	LTE-FDD (SC-FDMA, 50% RB, 3 MHz, 64-QAM)	X	2.17	65.92	11.96	0.00	150.0	± 9.6 %
		Y	1.77	64.27	10.86		150.0	
		Z	1.82	64.33	10.53		150.0	
10301-AAA	IEEE 802.16e WiMAX (29:18, 5ms, 10MHz, QPSK, PUSC)	X	4.60	64.65	17.23	4.17	50.0	± 9.6 %
		Y	4.45	64.38	17.09		50.0	
		Z	4.36	64.09	16.80		50.0	
10302-AAA	IEEE 802.16e WiMAX (29:18, 5ms, 10MHz, QPSK, PUSC, 3 CTRL symbols)	X	5.05	65.20	17.90	4.98	50.0	± 9.6 %
		Y	4.99	65.36	18.00		50.0	
		Z	4.96	65.32	17.84		50.0	

Certificate No: EX3-7461\_May17

Page 23 of 38

EX3DV4- SN:7461

May 26, 2017

10303-AAA	IEEE 802.16e WiMAX (31:15, 5ms, 10MHz, 64QAM, PUSC)	X	4.80	64.80	17.74	4.96	50.0	± 9.6 %
		Y	4.73	64.93	17.81		50.0	
		Z	4.70	64.90	17.64		50.0	
10304-AAA	IEEE 802.16e WiMAX (29:18, 5ms, 10MHz, 64QAM, PUSC)	X	4.62	64.76	17.29	4.17	50.0	± 9.6 %
		Y	4.56	64.89	17.36		50.0	
		Z	4.53	64.87	17.20		50.0	
10305-AAA	IEEE 802.16e WiMAX (31:15, 10ms, 10MHz, 64QAM, PUSC, 15 symbols)	X	4.09	65.38	18.77	6.02	35.0	± 9.6 %
		Y	4.05	65.75	18.99		35.0	
		Z	4.05	65.83	18.70		35.0	
10306-AAA	IEEE 802.16e WiMAX (29:18, 10ms, 10MHz, 64QAM, PUSC, 18 symbols)	X	4.48	64.86	18.48	6.02	35.0	± 9.6 %
		Y	4.43	65.13	18.59		35.0	
		Z	4.42	65.19	18.43		35.0	
10307-AAA	IEEE 802.16e WiMAX (29:18, 10ms, 10MHz, QPSK, PUSC, 18 symbols)	X	4.36	65.03	18.46	6.02	35.0	± 9.6 %
		Y	4.32	65.27	18.56		35.0	
		Z	4.31	65.31	18.39		35.0	
10308-AAA	IEEE 802.16e WiMAX (29:18, 10ms, 10MHz, 16QAM, PUSC)	X	4.33	65.13	18.55	6.02	35.0	± 9.6 %
		Y	4.29	65.41	18.67		35.0	
		Z	4.28	65.45	18.50		35.0	
10309-AAA	IEEE 802.16e WiMAX (29:18, 10ms, 10MHz, 16QAM, AMC 2x3, 18 symbols)	X	4.54	65.10	18.63	6.02	35.0	± 9.6 %
		Y	4.49	65.35	18.74		35.0	
		Z	4.47	65.37	18.56		35.0	
10310-AAA	IEEE 802.16e WiMAX (29:18, 10ms, 10MHz, QPSK, AMC 2x3, 18 symbols)	X	4.42	64.90	18.44	6.02	35.0	± 9.6 %
		Y	4.36	65.17	18.56		35.0	
		Z	4.37	65.23	18.41		35.0	
10311-AAB	LTE-FDD (SC-FDMA, 100% RB, 15 MHz, QPSK)	X	3.38	70.31	16.99	0.00	150.0	± 9.6 %
		Y	3.40	70.65	17.25		150.0	
		Z	3.20	69.64	16.67		150.0	
10313-AAA	iDEN 1:3	X	2.13	66.45	12.50	6.99	70.0	± 9.6 %
		Y	2.07	66.58	12.68		70.0	
		Z	2.09	66.62	12.74		70.0	
10314-AAA	iDEN 1:6	X	2.76	69.72	16.53	10.00	30.0	± 9.6 %
		Y	2.84	70.51	16.98		30.0	
		Z	2.83	70.44	17.02		30.0	
10315-AAB	IEEE 802.11b WiFi 2.4 GHz (DSSS, 1 Mbps, 96pc duty cycle)	X	1.08	64.15	15.65	0.17	150.0	± 9.6 %
		Y	1.09	64.50	15.97		150.0	
		Z	1.06	63.83	15.31		150.0	
10316-AAB	IEEE 802.11g WiFi 2.4 GHz (ERP-OFDM, 6 Mbps, 96pc duty cycle)	X	4.62	66.62	16.29	0.17	150.0	± 9.6 %
		Y	4.59	66.73	16.38		150.0	
		Z	4.54	66.61	16.23		150.0	
10317-AAB	IEEE 802.11a WiFi 5 GHz (OFDM, 6 Mbps, 96pc duty cycle)	X	4.62	66.62	16.29	0.17	150.0	± 9.6 %
		Y	4.59	66.73	16.38		150.0	
		Z	4.54	66.61	16.23		150.0	
10400-AAC	IEEE 802.11ac WiFi (20MHz, 64-QAM, 99pc duty cycle)	X	4.80	67.16	16.45	0.00	150.0	± 9.6 %
		Y	4.75	67.26	16.54		150.0	
		Z	4.68	67.10	16.37		150.0	
10401-AAC	IEEE 802.11ac WiFi (40MHz, 64-QAM, 99pc duty cycle)	X	5.45	67.22	16.52	0.00	150.0	± 9.6 %
		Y	5.44	67.36	16.65		150.0	
		Z	5.39	67.25	16.51		150.0	

Certificate No: EX3-7461\_May17

Page 24 of 38

EX3DV4- SN:7461

May 26, 2017

10402-AAC	IEEE 802.11ac WiFi (80MHz, 64-QAM, 99pc duty cycle)	X	5.74	67.69	16.61	0.00	150.0	± 9.6 %
		Y	5.89	67.69	16.66		150.0	
		Z	5.64	67.55	16.52		150.0	
10403-AAB	CDMA2000 (1xEV-DO, Rev. 0)	X	1.97	72.95	16.47	0.00	115.0	± 9.6 %
		Y	2.21	75.00	17.08		115.0	
		Z	1.64	70.60	14.94		115.0	
10404-AAB	CDMA2000 (1xEV-DO, Rev. A)	X	1.97	72.95	16.47	0.00	115.0	± 9.6 %
		Y	2.21	75.00	17.08		115.0	
		Z	1.64	70.60	14.94		115.0	
10406-AAB	CDMA2000, RC3, SO32, SCH0, Full Rate	X	100.00	117.69	28.42	0.00	100.0	± 9.6 %
		Y	100.00	122.70	30.29		100.0	
		Z	100.00	115.56	27.19		100.0	
10410-AAB	LTE-TDD (SC-FDMA, 1 RB, 10 MHz, QPSK, UL Subframe=2,3,4,7,8,9)	X	4.03	76.38	15.84	3.23	80.0	± 9.6 %
		Y	2.58	72.84	14.69		80.0	
		Z	3.34	75.33	15.49		80.0	
10415-AAA	IEEE 802.11b WiFi 2.4 GHz (DSSS, 1 Mbps, 99pc duty cycle)	X	1.03	63.74	15.42	0.00	150.0	± 9.6 %
		Y	1.05	64.15	15.77		150.0	
		Z	1.02	63.45	15.08		150.0	
10416-AAA	IEEE 802.11g WiFi 2.4 GHz (ERP-OFDM, 6 Mbps, 99pc duty cycle)	X	4.62	66.81	16.40	0.00	150.0	± 9.6 %
		Y	4.58	66.93	16.49		150.0	
		Z	4.53	66.79	16.33		150.0	
10417-AAA	IEEE 802.11ah WiFi 5 GHz (OFDM, 8 Mbps, 99pc duty cycle)	X	4.62	66.81	16.40	0.00	150.0	± 9.6 %
		Y	4.58	66.93	16.49		150.0	
		Z	4.53	66.79	16.33		150.0	
10418-AAA	IEEE 802.11g WiFi 2.4 GHz (DSSS-OFDM, 6 Mbps, 99pc duty cycle, Long preamble)	X	4.61	66.97	16.42	0.00	150.0	± 9.6 %
		Y	4.58	67.10	16.52		150.0	
		Z	4.52	66.97	16.36		150.0	
10419-AAA	IEEE 802.11g WiFi 2.4 GHz (DSSS-OFDM, 6 Mbps, 99pc duty cycle, Short preamble)	X	4.63	66.92	16.42	0.00	150.0	± 9.6 %
		Y	4.60	67.04	16.52		150.0	
		Z	4.54	66.91	16.36		150.0	
10422-AAA	IEEE 802.11n (HT Greenfield, 7.2 Mbps, BPSK)	X	4.75	66.92	16.43	0.00	150.0	± 9.6 %
		Y	4.71	67.03	16.52		150.0	
		Z	4.66	66.90	16.36		150.0	
10423-AAA	IEEE 802.11n (HT Greenfield, 43.3 Mbps, 16-QAM)	X	4.93	67.26	16.55	0.00	150.0	± 9.6 %
		Y	4.88	67.35	16.64		150.0	
		Z	4.82	67.20	16.47		150.0	
10424-AAA	IEEE 802.11n (HT Greenfield, 72.2 Mbps, 64-QAM)	X	4.85	67.21	16.53	0.00	150.0	± 9.6 %
		Y	4.80	67.31	16.61		150.0	
		Z	4.74	67.16	16.45		150.0	
10425-AAA	IEEE 802.11n (HT Greenfield, 15 Mbps, BPSK)	X	5.43	67.49	16.66	0.00	150.0	± 9.6 %
		Y	5.40	67.56	16.75		150.0	
		Z	5.34	67.42	16.60		150.0	
10426-AAA	IEEE 802.11n (HT Greenfield, 90 Mbps, 16-QAM)	X	5.43	67.50	16.66	0.00	150.0	± 9.6 %
		Y	5.40	67.59	16.76		150.0	
		Z	5.35	67.46	16.62		150.0	

Certificate No: EX3-7461\_May17

Page 25 of 38

EX3DV4- SN:7461

May 26, 2017

10427-AAA	IEEE 802.11n (HT Greenfield, 150 Mbps, 64-QAM)	X	5.45	67.49	16.65	0.00	150.0	± 9.6 %
		Y	5.41	67.56	16.74		150.0	
		Z	5.36	67.43	16.60		150.0	
10430-AAA	LTE-FDD (OFDMA, 5 MHz, E-TM 3.1)	X	4.53	71.75	16.94	0.00	150.0	± 9.6 %
		Y	4.49	72.03	18.98		150.0	
		Z	4.46	72.11	18.97		150.0	
10431-AAA	LTE-FDD (OFDMA, 10 MHz, E-TM 3.1)	X	4.34	67.44	16.49	0.00	150.0	± 9.6 %
		Y	4.29	67.60	16.57		150.0	
		Z	4.21	67.41	16.35		150.0	
10432-AAA	LTE-FDD (OFDMA, 15 MHz, E-TM 3.1)	X	4.62	67.28	16.50	0.00	150.0	± 9.6 %
		Y	4.59	67.40	16.59		150.0	
		Z	4.51	67.24	16.41		150.0	
10433-AAA	LTE-FDD (OFDMA, 20 MHz, E-TM 3.1)	X	4.88	67.25	16.55	0.00	150.0	± 9.6 %
		Y	4.82	67.34	16.63		150.0	
		Z	4.75	67.20	16.47		150.0	
10434-AAA	W-CDMA (BS Test Model 1, 64 DPCH)	X	4.72	72.87	19.06	0.00	150.0	± 9.6 %
		Y	4.69	73.24	19.10		150.0	
		Z	4.66	73.29	18.95		150.0	
10435-AAB	LTE-TDD (SC-FDMA, 1 RB, 20 MHz, QPSK, UL Subframe=2,3,4,7,8,9)	X	3.87	75.85	15.61	3.23	80.0	± 9.6 %
		Y	2.51	72.44	14.49		80.0	
		Z	3.22	74.83	15.26		80.0	
10447-AAA	LTE-FDD (OFDMA, 5 MHz, E-TM 3.1, Clipping 44%)	X	3.66	67.63	16.01	0.00	150.0	± 9.6 %
		Y	3.61	67.66	16.05		150.0	
		Z	3.51	67.52	15.69		150.0	
10448-AAA	LTE-FDD (OFDMA, 10 MHz, E-TM 3.1, Clipping 44%)	X	4.17	67.23	16.35	0.00	150.0	± 9.6 %
		Y	4.12	67.39	16.44		150.0	
		Z	4.05	67.19	16.22		150.0	
10449-AAA	LTE-FDD (OFDMA, 15 MHz, E-TM 3.1, Clipping 44%)	X	4.42	67.12	16.42	0.00	150.0	± 9.6 %
		Y	4.39	67.25	16.51		150.0	
		Z	4.33	67.08	16.32		150.0	
10450-AAA	LTE-FDD (OFDMA, 20 MHz, E-TM 3.1, Clipping 44%)	X	4.61	67.03	16.42	0.00	150.0	± 9.6 %
		Y	4.56	67.13	16.50		150.0	
		Z	4.52	66.97	16.33		150.0	
10451-AAA	W-CDMA (BS Test Model 1, 64 DPCH, Clipping 44%)	X	3.69	67.95	15.74	0.00	150.0	± 9.6 %
		Y	3.53	68.16	15.73		150.0	
		Z	3.40	67.71	15.30		150.0	
10456-AAA	IEEE 802.11ac WiFi (160MHz, 64-QAM, 99pc duty cycle)	X	6.28	68.04	16.79	0.00	150.0	± 9.6 %
		Y	6.25	68.06	16.86		150.0	
		Z	6.21	67.94	16.73		150.0	
10457-AAA	UMTS-FDD (DC-HSDPA)	X	3.83	65.44	16.13	0.00	150.0	± 9.6 %
		Y	3.82	65.55	16.22		150.0	
		Z	3.79	65.44	16.04		150.0	
10458-AAA	CDMA2000 (1xEV-DO, Rev. B, 2 carriers)	X	3.40	67.18	15.16	0.00	150.0	± 9.6 %
		Y	3.34	67.41	15.10		150.0	
		Z	3.20	66.92	14.61		150.0	
10459-AAA	CDMA2000 (1xEV-DO, Rev. B, 3 carriers)	X	4.47	65.24	15.68	0.00	150.0	± 9.6 %
		Y	4.49	65.80	16.06		150.0	
		Z	4.29	65.22	15.59		150.0	

Certificate No: EX3-7461\_May17

Page 26 of 38

EX3DV4- SN.7461

May 26, 2017

10460-AAA	UMTS-FDD (WCDMA, AMR)	X	1.06	71.58	18.23	0.00	150.0	± 9.6 %
		Y	1.17	73.71	19.36		150.0	
		Z	0.97	69.98	17.25		150.0	
10461-AAA	LTE-TDD (SC-FDMA, 1 RB, 1.4 MHz, QPSK, UL Subframe=2,3,4,7,8,9)	X	1.88	69.42	14.22	3.29	80.0	± 9.6 %
		Y	1.34	66.66	13.17		80.0	
		Z	1.50	67.85	13.66		80.0	
10462-AAA	LTE-TDD (SC-FDMA, 1 RB, 1.4 MHz, 16-QAM, UL Subframe=2,3,4,7,8,9)	X	0.94	60.00	7.04	3.23	80.0	± 9.6 %
		Y	0.83	60.00	6.92		80.0	
		Z	0.86	60.00	6.80		80.0	
10463-AAA	LTE-TDD (SC-FDMA, 1 RB, 1.4 MHz, 64-QAM, UL Subframe=2,3,4,7,8,9)	X	0.98	60.00	6.60	3.23	80.0	± 9.6 %
		Y	0.87	60.00	6.42		80.0	
		Z	0.89	60.00	6.31		80.0	
10464-AAA	LTE-TDD (SC-FDMA, 1 RB, 3 MHz, QPSK, UL Subframe=2,3,4,7,8,9)	X	1.49	66.62	12.50	3.23	80.0	± 9.6 %
		Y	1.09	64.35	11.56		80.0	
		Z	1.21	65.35	11.99		80.0	
10465-AAA	LTE-TDD (SC-FDMA, 1 RB, 3 MHz, 16-QAM, UL Subframe=2,3,4,7,8,9)	X	0.94	60.00	6.97	3.23	80.0	± 9.6 %
		Y	0.83	60.00	6.85		80.0	
		Z	0.86	60.00	6.74		80.0	
10466-AAA	LTE-TDD (SC-FDMA, 1 RB, 3 MHz, 64-QAM, UL Subframe=2,3,4,7,8,9)	X	0.98	60.00	6.56	3.23	80.0	± 9.6 %
		Y	0.87	60.00	6.37		80.0	
		Z	0.90	60.00	6.27		80.0	
10467-AAB	LTE-TDD (SC-FDMA, 1 RB, 5 MHz, QPSK, UL Subframe=2,3,4,7,8,9)	X	1.53	66.95	12.67	3.23	80.0	± 9.6 %
		Y	1.11	64.61	11.70		80.0	
		Z	1.23	65.65	12.15		80.0	
10468-AAB	LTE-TDD (SC-FDMA, 1 RB, 5 MHz, 16-QAM, UL Subframe=2,3,4,7,8,9)	X	0.94	60.00	6.98	3.23	80.0	± 9.6 %
		Y	0.83	60.00	6.86		80.0	
		Z	0.85	60.00	6.75		80.0	
10469-AAB	LTE-TDD (SC-FDMA, 1 RB, 5 MHz, 64-QAM, UL Subframe=2,3,4,7,8,9)	X	0.98	60.00	6.55	3.23	80.0	± 9.6 %
		Y	0.87	60.00	6.37		80.0	
		Z	0.89	60.00	6.26		80.0	
10470-AAB	LTE-TDD (SC-FDMA, 1 RB, 10 MHz, QPSK, UL Subframe=2,3,4,7,8,9)	X	1.52	66.91	12.64	3.23	80.0	± 9.6 %
		Y	1.10	64.56	11.68		80.0	
		Z	1.23	65.62	12.13		80.0	
10471-AAB	LTE-TDD (SC-FDMA, 1 RB, 10 MHz, 16-QAM, UL Subframe=2,3,4,7,8,9)	X	0.94	60.00	6.97	3.23	80.0	± 9.6 %
		Y	0.83	60.00	6.85		80.0	
		Z	0.85	60.00	6.73		80.0	
10472-AAB	LTE-TDD (SC-FDMA, 1 RB, 10 MHz, 64-QAM, UL Subframe=2,3,4,7,8,9)	X	0.98	60.00	6.54	3.23	80.0	± 9.6 %
		Y	0.87	60.00	6.35		80.0	
		Z	0.89	60.00	6.24		80.0	
10473-AAB	LTE-TDD (SC-FDMA, 1 RB, 15 MHz, QPSK, UL Subframe=2,3,4,7,8,9)	X	1.52	66.89	12.63	3.23	80.0	± 9.6 %
		Y	1.10	64.56	11.67		80.0	
		Z	1.23	65.61	12.12		80.0	
10474-AAB	LTE-TDD (SC-FDMA, 1 RB, 15 MHz, 16-QAM, UL Subframe=2,3,4,7,8,9)	X	0.94	60.00	6.97	3.23	80.0	± 9.6 %
		Y	0.83	60.00	6.84		80.0	
		Z	0.85	60.00	6.73		80.0	
10475-AAB	LTE-TDD (SC-FDMA, 1 RB, 15 MHz, 64-QAM, UL Subframe=2,3,4,7,8,9)	X	0.98	60.00	6.54	3.23	80.0	± 9.6 %
		Y	0.87	60.00	6.35		80.0	
		Z	0.89	60.00	6.25		80.0	

Certificate No: EX3-7461\_May17

Page 27 of 38

EX30V4-SN:7461

May 26, 2017

10477-AAB	LTE-TDD (SC-FDMA, 1 RB, 20 MHz, 16-QAM, UL Subframe=2,3,4,7,8,9)	X	0.94	60.00	6.95	3.23	80.0	± 9.6 %
		Y	0.83	60.00	6.82		80.0	
		Z	0.85	60.00	6.71		80.0	
10478-AAB	LTE-TDD (SC-FDMA, 1 RB, 20 MHz, 64-QAM, UL Subframe=2,3,4,7,8,9)	X	0.98	60.00	6.53	3.23	80.0	± 9.6 %
		Y	0.87	60.00	6.34		80.0	
		Z	0.89	60.00	6.23		80.0	
10479-AAA	LTE-TDD (SC-FDMA, 50% RB, 1.4 MHz, QPSK, UL Subframe=2,3,4,7,8,9)	X	2.79	70.35	16.45	3.23	80.0	± 9.6 %
		Y	2.49	69.50	15.92		80.0	
		Z	2.66	70.40	16.19		80.0	
10480-AAA	LTE-TDD (SC-FDMA, 50% RB, 1.4 MHz, 16-QAM, UL Subframe=2,3,4,7,8,9)	X	2.73	67.19	13.52	3.23	80.0	± 9.6 %
		Y	2.20	65.37	12.49		80.0	
		Z	2.31	65.90	12.52		80.0	
10481-AAA	LTE-TDD (SC-FDMA, 50% RB, 1.4 MHz, 64-QAM, UL Subframe=2,3,4,7,8,9)	X	2.45	65.57	12.48	3.23	80.0	± 9.6 %
		Y	1.97	63.83	11.43		80.0	
		Z	2.04	64.15	11.38		80.0	
10482-AAA	LTE-TDD (SC-FDMA, 50% RB, 3 MHz, QPSK, UL Subframe=2,3,4,7,8,9)	X	2.04	66.44	14.21	2.23	80.0	± 9.6 %
		Y	1.95	66.42	14.02		80.0	
		Z	1.77	65.13	13.19		80.0	
10483-AAA	LTE-TDD (SC-FDMA, 50% RB, 3 MHz, 16-QAM, UL Subframe=2,3,4,7,8,9)	X	2.51	65.69	13.20	2.23	80.0	± 9.6 %
		Y	2.11	64.03	12.07		80.0	
		Z	2.10	63.96	11.84		80.0	
10484-AAA	LTE-TDD (SC-FDMA, 50% RB, 3 MHz, 64-QAM, UL Subframe=2,3,4,7,8,9)	X	2.51	65.43	13.10	2.23	80.0	± 9.6 %
		Y	2.11	63.78	11.96		80.0	
		Z	2.09	63.66	11.72		80.0	
10485-AAB	LTE-TDD (SC-FDMA, 50% RB, 5 MHz, QPSK, UL Subframe=2,3,4,7,8,9)	X	2.36	67.93	15.69	2.23	80.0	± 9.6 %
		Y	2.33	66.36	15.85		80.0	
		Z	2.15	67.17	15.13		80.0	
10486-AAB	LTE-TDD (SC-FDMA, 50% RB, 5 MHz, 16-QAM, UL Subframe=2,3,4,7,8,9)	X	2.57	65.99	14.48	2.23	80.0	± 9.6 %
		Y	2.49	66.02	14.34		80.0	
		Z	2.35	65.24	13.77		80.0	
10487-AAB	LTE-TDD (SC-FDMA, 50% RB, 5 MHz, 64-QAM, UL Subframe=2,3,4,7,8,9)	X	2.61	65.83	14.41	2.23	80.0	± 9.6 %
		Y	2.52	65.80	14.23		80.0	
		Z	2.38	65.06	13.67		80.0	
10488-AAB	LTE-TDD (SC-FDMA, 50% RB, 10 MHz, QPSK, UL Subframe=2,3,4,7,8,9)	X	2.83	68.45	16.52	2.23	80.0	± 9.6 %
		Y	2.80	68.85	16.78		80.0	
		Z	2.65	67.93	16.26		80.0	
10489-AAB	LTE-TDD (SC-FDMA, 50% RB, 10 MHz, 16-QAM, UL Subframe=2,3,4,7,8,9)	X	3.00	66.44	15.79	2.23	80.0	± 9.6 %
		Y	2.95	66.64	15.89		80.0	
		Z	2.86	66.15	15.52		80.0	
10490-AAB	LTE-TDD (SC-FDMA, 50% RB, 10 MHz, 64-QAM, UL Subframe=2,3,4,7,8,9)	X	3.11	66.41	15.81	2.23	80.0	± 9.6 %
		Y	3.06	66.59	15.89		80.0	
		Z	2.97	66.14	15.54		80.0	
10491-AAB	LTE-TDD (SC-FDMA, 50% RB, 15 MHz, QPSK, UL Subframe=2,3,4,7,8,9)	X	3.20	67.98	16.46	2.23	80.0	± 9.6 %
		Y	3.17	68.25	16.69		80.0	
		Z	3.04	67.57	16.29		80.0	
10492-AAB	LTE-TDD (SC-FDMA, 50% RB, 15 MHz, 16-QAM, UL Subframe=2,3,4,7,8,9)	X	3.43	66.30	16.03	2.23	80.0	± 9.6 %
		Y	3.37	66.43	16.14		80.0	
		Z	3.29	66.06	15.86		80.0	



EX3DV4- SN:7461

May 26, 2017

10493-AAB	LTE-TDD (SC-FDMA, 50% RB, 15 MHz, 64-QAM, UL Subframe=2,3,4,7,8,9)	X	3.51	66.25	16.03	2.23	80.0	± 9.6 %
		Y	3.45	66.37	16.13		80.0	
		Z	3.37	66.02	15.96		80.0	
10494-AAB	LTE-TDD (SC-FDMA, 50% RB, 20 MHz, QPSK, UL Subframe=2,3,4,7,8,9)	X	3.38	69.06	16.75	2.23	80.0	± 9.6 %
		Y	3.35	69.36	17.01		80.0	
		Z	3.18	68.54	16.56		80.0	
10495-AAB	LTE-TDD (SC-FDMA, 50% RB, 20 MHz, 16-QAM, UL Subframe=2,3,4,7,8,9)	X	3.44	66.63	16.18	2.23	80.0	± 9.6 %
		Y	3.38	66.74	16.30		80.0	
		Z	3.30	66.33	16.01		80.0	
10496-AAB	LTE-TDD (SC-FDMA, 50% RB, 20 MHz, 64-QAM, UL Subframe=2,3,4,7,8,9)	X	3.54	66.49	16.17	2.23	80.0	± 9.6 %
		Y	3.48	66.59	16.26		80.0	
		Z	3.40	66.23	16.01		80.0	
10497-AAA	LTE-TDD (SC-FDMA, 100% RB, 1.4 MHz, QPSK, UL Subframe=2,3,4,7,8,9)	X	1.56	63.53	11.99	2.23	80.0	± 9.6 %
		Y	1.42	62.85	11.33		80.0	
		Z	1.30	61.84	10.54		80.0	
10498-AAA	LTE-TDD (SC-FDMA, 100% RB, 1.4 MHz, 16-QAM, UL Subframe=2,3,4,7,8,9)	X	1.51	60.89	9.72	2.23	80.0	± 9.6 %
		Y	1.33	60.00	8.83		80.0	
		Z	1.31	60.00	8.56		80.0	
10499-AAA	LTE-TDD (SC-FDMA, 100% RB, 1.4 MHz, 64-QAM, UL Subframe=2,3,4,7,8,9)	X	1.50	60.60	9.44	2.23	80.0	± 9.6 %
		Y	1.35	60.00	8.69		80.0	
		Z	1.33	60.00	8.42		80.0	
10500-AAA	LTE-TDD (SC-FDMA, 100% RB, 3 MHz, QPSK, UL Subframe=2,3,4,7,8,9)	X	2.53	67.96	15.97	2.23	80.0	± 9.6 %
		Y	2.51	68.42	16.19		80.0	
		Z	2.34	67.38	15.56		80.0	
10501-AAA	LTE-TDD (SC-FDMA, 100% RB, 3 MHz, 16-QAM, UL Subframe=2,3,4,7,8,9)	X	2.76	66.23	15.02	2.23	80.0	± 9.6 %
		Y	2.70	66.38	14.99		80.0	
		Z	2.58	65.73	14.51		80.0	
10502-AAA	LTE-TDD (SC-FDMA, 100% RB, 3 MHz, 64-QAM, UL Subframe=2,3,4,7,8,9)	X	2.83	66.20	14.96	2.23	80.0	± 9.6 %
		Y	2.76	66.32	14.92		80.0	
		Z	2.64	65.69	14.44		80.0	
10503-AAB	LTE-TDD (SC-FDMA, 100% RB, 5 MHz, QPSK, UL Subframe=2,3,4,7,8,9)	X	2.80	68.30	16.44	2.23	80.0	± 9.6 %
		Y	2.78	68.70	16.70		80.0	
		Z	2.62	67.78	16.17		80.0	
10504-AAB	LTE-TDD (SC-FDMA, 100% RB, 5 MHz, 16-QAM, UL Subframe=2,3,4,7,8,9)	X	2.99	66.37	15.74	2.23	80.0	± 9.6 %
		Y	2.94	66.56	15.84		80.0	
		Z	2.85	66.07	15.47		80.0	
10505-AAB	LTE-TDD (SC-FDMA, 100% RB, 5 MHz, 64-QAM, UL Subframe=2,3,4,7,8,9)	X	3.10	66.33	15.76	2.23	80.0	± 9.6 %
		Y	3.04	66.51	15.84		80.0	
		Z	2.95	66.06	15.49		80.0	
10506-AAB	LTE-TDD (SC-FDMA, 100% RB, 10 MHz, QPSK, UL Subframe=2,3,4,7,8,9)	X	3.35	68.94	16.69	2.23	80.0	± 9.6 %
		Y	3.32	69.24	16.94		80.0	
		Z	3.16	68.43	16.50		80.0	
10507-AAB	LTE-TDD (SC-FDMA, 100% RB, 10 MHz, 16-QAM, UL Subframe=2,3,4,7,8,9)	X	3.42	66.57	16.14	2.23	80.0	± 9.6 %
		Y	3.37	66.68	16.26		80.0	
		Z	3.29	66.26	15.97		80.0	

Certificate No: EX3-7461\_May17

Page 29 of 38

EX3DV4- SN:7461

May 26, 2017

10508-AAB	LTE-TDD (SC-FDMA, 100% RB, 10 MHz, 64-QAM, UL Subframe=2,3,4,7,8,9)	X	3.53	66.43	16.13	2.23	80.0	± 9.6 %
		Y	3.47	66.53	16.24		80.0	
		Z	3.39	66.17	15.97		80.0	
10509-AAB	LTE-TDD (SC-FDMA, 100% RB, 15 MHz, QPSK, UL Subframe=2,3,4,7,8,9)	X	3.80	68.52	16.55	2.23	80.0	± 9.6 %
		Y	3.76	68.70	16.75		80.0	
		Z	3.63	68.11	16.42		80.0	
10510-AAB	LTE-TDD (SC-FDMA, 100% RB, 15 MHz, 16-QAM, UL Subframe=2,3,4,7,8,9)	X	3.95	66.71	16.32	2.23	80.0	± 9.6 %
		Y	3.88	66.75	16.42		80.0	
		Z	3.81	66.42	16.19		80.0	
10511-AAB	LTE-TDD (SC-FDMA, 100% RB, 15 MHz, 64-QAM, UL Subframe=2,3,4,7,8,9)	X	4.02	66.54	16.30	2.23	80.0	± 9.6 %
		Y	3.95	66.58	16.39		80.0	
		Z	3.88	66.28	16.17		80.0	
10512-AAB	LTE-TDD (SC-FDMA, 100% RB, 20 MHz, QPSK, UL Subframe=2,3,4,7,8,9)	X	3.64	69.53	16.81	2.23	80.0	± 9.6 %
		Y	3.61	69.77	17.04		80.0	
		Z	3.64	69.00	16.84		80.0	
10513-AAB	LTE-TDD (SC-FDMA, 100% RB, 20 MHz, 16-QAM, UL Subframe=2,3,4,7,8,9)	X	3.81	66.87	16.36	2.23	80.0	± 9.6 %
		Y	3.75	66.91	16.47		80.0	
		Z	3.68	66.53	16.21		80.0	
10514-AAB	LTE-TDD (SC-FDMA, 100% RB, 20 MHz, 64-QAM, UL Subframe=2,3,4,7,8,9)	X	3.86	66.57	16.30	2.23	80.0	± 9.6 %
		Y	3.80	66.60	16.40		80.0	
		Z	3.73	66.27	16.17		80.0	
10515-AAA	IEEE 802.11b WiFi 2.4 GHz (DSSS, 2 Mbps, 99pc duty cycle)	X	0.99	64.00	15.53	0.00	150.0	± 9.6 %
		Y	1.01	64.45	15.91		150.0	
		Z	0.98	63.67	15.17		150.0	
10516-AAA	IEEE 802.11b WiFi 2.4 GHz (DSSS, 5.5 Mbps, 99pc duty cycle)	X	0.85	77.90	21.31	0.00	150.0	± 9.6 %
		Y	1.17	84.12	24.13		150.0	
		Z	0.89	73.67	19.23		150.0	
10517-AAA	IEEE 802.11b WiFi 2.4 GHz (DSSS, 11 Mbps, 99pc duty cycle)	X	0.88	66.81	16.68	0.00	150.0	± 9.6 %
		Y	0.91	67.73	17.34		150.0	
		Z	0.85	65.98	16.05		150.0	
10518-AAA	IEEE 802.11a/h WiFi 5 GHz (OFDM, 9 Mbps, 99pc duty cycle)	X	4.61	68.90	16.39	0.00	150.0	± 9.6 %
		Y	4.58	67.01	16.48		150.0	
		Z	4.52	66.88	16.31		150.0	
10519-AAA	IEEE 802.11a/h WiFi 5 GHz (OFDM, 12 Mbps, 99pc duty cycle)	X	4.81	67.15	16.51	0.00	150.0	± 9.6 %
		Y	4.76	67.24	16.59		150.0	
		Z	4.70	67.09	16.42		150.0	
10520-AAA	IEEE 802.11a/h WiFi 5 GHz (OFDM, 18 Mbps, 99pc duty cycle)	X	4.66	67.14	16.45	0.00	150.0	± 9.6 %
		Y	4.62	67.22	16.53		150.0	
		Z	4.55	67.06	16.35		150.0	
10521-AAA	IEEE 802.11a/h WiFi 5 GHz (OFDM, 24 Mbps, 99pc duty cycle)	X	4.60	67.14	16.44	0.00	150.0	± 9.6 %
		Y	4.55	67.23	16.52		150.0	
		Z	4.49	67.06	16.34		150.0	
10522-AAA	IEEE 802.11a/h WiFi 5 GHz (OFDM, 36 Mbps, 99pc duty cycle)	X	4.65	67.18	16.50	0.00	150.0	± 9.6 %
		Y	4.61	67.31	16.60		150.0	
		Z	4.55	67.16	16.43		150.0	

Certificate No: EX3-7461\_May17

Page 30 of 38

EX3DV4- SN:7461

May 26, 2017

10523-AAA	IEEE 802.11a/n WiFi 5 GHz (OFDM, 48 Mbps, 99pc duty cycle)	X	4.53	67.07	16.35	0.00	150.0	± 9.6 %
		Y	4.49	67.20	16.46		150.0	
		Z	4.44	67.05	16.29		150.0	
10524-AAA	IEEE 802.11a/n WiFi 5 GHz (OFDM, 54 Mbps, 99pc duty cycle)	X	4.60	67.11	16.47	0.00	150.0	± 9.6 %
		Y	4.55	67.23	16.57		150.0	
		Z	4.49	67.08	16.39		150.0	
10525-AAA	IEEE 802.11ac WiFi (20MHz, MCS0, 99pc duty cycle)	X	4.57	66.17	16.07	0.00	150.0	± 9.6 %
		Y	4.55	66.29	16.17		150.0	
		Z	4.49	66.14	16.00		150.0	
10526-AAA	IEEE 802.11ac WiFi (20MHz, MCS1, 99pc duty cycle)	X	4.76	66.55	16.21	0.00	150.0	± 9.6 %
		Y	4.72	66.66	16.31		150.0	
		Z	4.65	66.50	16.13		150.0	
10527-AAA	IEEE 802.11ac WiFi (20MHz, MCS2, 99pc duty cycle)	X	4.68	66.53	16.17	0.00	150.0	± 9.6 %
		Y	4.64	66.63	16.26		150.0	
		Z	4.57	66.47	16.08		150.0	
10528-AAA	IEEE 802.11ac WiFi (20MHz, MCS3, 99pc duty cycle)	X	4.70	66.54	16.20	0.00	150.0	± 9.6 %
		Y	4.66	66.65	16.29		150.0	
		Z	4.59	66.48	16.11		150.0	
10529-AAA	IEEE 802.11ac WiFi (20MHz, MCS4, 99pc duty cycle)	X	4.70	66.54	16.20	0.00	150.0	± 9.6 %
		Y	4.66	66.65	16.29		150.0	
		Z	4.59	66.48	16.11		150.0	
10531-AAA	IEEE 802.11ac WiFi (20MHz, MCS6, 99pc duty cycle)	X	4.70	66.68	16.22	0.00	150.0	± 9.6 %
		Y	4.65	66.76	16.31		150.0	
		Z	4.58	66.57	16.12		150.0	
10532-AAA	IEEE 802.11ac WiFi (20MHz, MCS7, 99pc duty cycle)	X	4.55	66.54	16.17	0.00	150.0	± 9.6 %
		Y	4.51	66.63	16.25		150.0	
		Z	4.44	66.44	16.06		150.0	
10533-AAA	IEEE 802.11ac WiFi (20MHz, MCS8, 99pc duty cycle)	X	4.71	66.68	16.18	0.00	150.0	± 9.6 %
		Y	4.67	66.70	16.28		150.0	
		Z	4.60	66.54	16.11		150.0	
10534-AAA	IEEE 802.11ac WiFi (40MHz, MCS0, 99pc duty cycle)	X	5.22	66.63	16.22	0.00	150.0	± 9.6 %
		Y	5.18	66.66	16.30		150.0	
		Z	5.12	66.53	16.15		150.0	
10535-AAA	IEEE 802.11ac WiFi (40MHz, MCS1, 99pc duty cycle)	X	5.28	66.76	16.28	0.00	150.0	± 9.6 %
		Y	5.25	66.86	16.38		150.0	
		Z	5.19	66.71	16.23		150.0	
10536-AAA	IEEE 802.11ac WiFi (40MHz, MCS2, 99pc duty cycle)	X	5.15	66.77	16.26	0.00	150.0	± 9.6 %
		Y	5.12	66.83	16.35		150.0	
		Z	5.06	66.67	16.19		150.0	
10537-AAA	IEEE 802.11ac WiFi (40MHz, MCS3, 99pc duty cycle)	X	5.21	66.73	16.24	0.00	150.0	± 9.6 %
		Y	5.18	66.79	16.33		150.0	
		Z	5.12	66.63	16.17		150.0	
10538-AAA	IEEE 802.11ac WiFi (40MHz, MCS4, 99pc duty cycle)	X	5.31	66.76	16.30	0.00	150.0	± 9.6 %
		Y	5.26	66.79	16.37		150.0	
		Z	5.20	66.64	16.21		150.0	
10540-AAA	IEEE 802.11ac WiFi (40MHz, MCS6, 99pc duty cycle)	X	5.23	66.75	16.31	0.00	150.0	± 9.6 %
		Y	5.20	66.82	16.40		150.0	
		Z	5.13	66.65	16.24		150.0	

Certificate No: EX3-7461\_May17

Page 31 of 38

EX3DV4- SN:7461

May 26, 2017

10541-AAA	IEEE 802.11ac WiFi (40MHz, MCS7, 99pc duty cycle)	X	5.20	66.63	16.25	0.00	150.0	± 9.6 %
		Y	5.17	66.69	16.32		150.0	
		Z	5.11	66.53	16.17		150.0	
10542-AAA	IEEE 802.11ac WiFi (40MHz, MCS8, 99pc duty cycle)	X	5.36	66.69	16.28	0.00	150.0	± 9.6 %
		Y	5.32	66.74	16.36		150.0	
		Z	5.26	66.60	16.21		150.0	
10543-AAA	IEEE 802.11ac WiFi (40MHz, MCS9, 99pc duty cycle)	X	5.44	66.71	16.31	0.00	150.0	± 9.6 %
		Y	5.40	66.76	16.39		150.0	
		Z	5.33	66.62	16.24		150.0	
10544-AAA	IEEE 802.11ac WiFi (80MHz, MCS0, 99pc duty cycle)	X	5.51	66.73	16.20	0.00	150.0	± 9.6 %
		Y	5.49	66.77	16.27		150.0	
		Z	5.44	66.64	16.13		150.0	
10545-AAA	IEEE 802.11ac WiFi (80MHz, MCS1, 99pc duty cycle)	X	5.71	67.12	16.34	0.00	150.0	± 9.6 %
		Y	5.68	67.18	16.43		150.0	
		Z	5.62	67.04	16.28		150.0	
10546-AAA	IEEE 802.11ac WiFi (80MHz, MCS2, 99pc duty cycle)	X	5.59	66.96	16.29	0.00	150.0	± 9.6 %
		Y	5.55	66.99	16.34		150.0	
		Z	5.50	66.82	16.19		150.0	
10547-AAA	IEEE 802.11ac WiFi (80MHz, MCS3, 99pc duty cycle)	X	5.67	67.02	16.30	0.00	150.0	± 9.6 %
		Y	5.62	67.02	16.35		150.0	
		Z	5.57	66.87	16.21		150.0	
10548-AAA	IEEE 802.11ac WiFi (80MHz, MCS4, 99pc duty cycle)	X	5.92	67.95	16.73	0.00	150.0	± 9.6 %
		Y	5.87	67.95	16.79		150.0	
		Z	5.79	67.71	16.59		150.0	
10550-AAA	IEEE 802.11ac WiFi (80MHz, MCS6, 99pc duty cycle)	X	5.61	66.95	16.28	0.00	150.0	± 9.6 %
		Y	5.58	67.00	16.36		150.0	
		Z	5.52	66.86	16.22		150.0	
10551-AAA	IEEE 802.11ac WiFi (80MHz, MCS7, 99pc duty cycle)	X	5.62	67.01	16.27	0.00	150.0	± 9.6 %
		Y	5.59	67.05	16.35		150.0	
		Z	5.53	66.90	16.20		150.0	
10552-AAA	IEEE 802.11ac WiFi (80MHz, MCS8, 99pc duty cycle)	X	5.53	66.80	16.18	0.00	150.0	± 9.6 %
		Y	5.50	66.85	16.26		150.0	
		Z	5.45	66.71	16.12		150.0	
10553-AAA	IEEE 802.11ac WiFi (80MHz, MCS9, 99pc duty cycle)	X	5.62	66.85	16.23	0.00	150.0	± 9.6 %
		Y	5.58	66.87	16.30		150.0	
		Z	5.53	66.73	16.16		150.0	
10554-AAA	IEEE 802.11ac WiFi (160MHz, MCS0, 99pc duty cycle)	X	5.91	67.08	16.28	0.00	150.0	± 9.6 %
		Y	5.89	67.11	16.34		150.0	
		Z	5.85	66.98	16.21		150.0	
10555-AAA	IEEE 802.11ac WiFi (160MHz, MCS1, 99pc duty cycle)	X	6.04	67.38	16.40	0.00	150.0	± 9.6 %
		Y	6.02	67.41	16.47		150.0	
		Z	5.97	67.27	16.33		150.0	
10556-AAA	IEEE 802.11ac WiFi (160MHz, MCS2, 99pc duty cycle)	X	6.06	67.42	16.42	0.00	150.0	± 9.6 %
		Y	6.04	67.46	16.49		150.0	
		Z	5.99	67.32	16.35		150.0	
10557-AAA	IEEE 802.11ac WiFi (160MHz, MCS3, 99pc duty cycle)	X	6.04	67.36	16.40	0.00	150.0	± 9.6 %
		Y	6.01	67.37	16.46		150.0	
		Z	5.95	67.22	16.32		150.0	

Certificate No: EX3-7461\_May17

Page 32 of 38

EX3DV4- SN:7461

May 26, 2017

10558-AAA	IEEE 802.11ac WiFi (160MHz, MCS4, 99pc duty cycle)	X	6.09	67.52	16.50	0.00	150.0	± 9.6 %
		Y	6.06	67.53	16.56		150.0	
		Z	6.00	67.37	16.41		150.0	
10560-AAA	IEEE 802.11ac WiFi (160MHz, MCS6, 99pc duty cycle)	X	6.09	67.37	16.46	0.00	150.0	± 9.6 %
		Y	6.05	67.37	16.52		150.0	
		Z	5.99	67.23	16.38		150.0	
10561-AAA	IEEE 802.11ac WiFi (160MHz, MCS7, 99pc duty cycle)	X	6.00	67.33	16.48	0.00	150.0	± 9.6 %
		Y	5.97	67.35	16.54		150.0	
		Z	5.92	67.20	16.40		150.0	
10562-AAA	IEEE 802.11ac WiFi (160MHz, MCS8, 99pc duty cycle)	X	6.14	67.75	16.69	0.00	150.0	± 9.6 %
		Y	6.10	67.73	16.73		150.0	
		Z	6.03	67.54	16.57		150.0	
10563-AAA	IEEE 802.11ac WiFi (160MHz, MCS9, 99pc duty cycle)	X	6.47	68.28	16.89	0.00	150.0	± 9.6 %
		Y	6.31	67.88	16.81		150.0	
		Z	6.18	67.60	16.56		150.0	
10564-AAA	IEEE 802.11g WiFi 2.4 GHz (DSSS-OFDM, 9 Mbps, 99pc duty cycle)	X	4.92	66.89	16.47	0.46	150.0	± 9.6 %
		Y	4.88	66.99	16.56		150.0	
		Z	4.83	66.86	16.40		150.0	
10565-AAA	IEEE 802.11g WiFi 2.4 GHz (DSSS-OFDM, 12 Mbps, 99pc duty cycle)	X	5.17	67.38	16.81	0.46	150.0	± 9.6 %
		Y	5.12	67.45	16.88		150.0	
		Z	5.06	67.32	16.73		150.0	
10566-AAA	IEEE 802.11g WiFi 2.4 GHz (DSSS-OFDM, 18 Mbps, 99pc duty cycle)	X	5.00	67.23	16.63	0.46	150.0	± 9.6 %
		Y	4.95	67.30	16.70		150.0	
		Z	4.89	67.15	16.54		150.0	
10567-AAA	IEEE 802.11g WiFi 2.4 GHz (DSSS-OFDM, 24 Mbps, 99pc duty cycle)	X	5.04	67.66	17.01	0.46	150.0	± 9.6 %
		Y	4.98	67.72	17.08		150.0	
		Z	4.93	67.59	16.93		150.0	
10568-AAA	IEEE 802.11g WiFi 2.4 GHz (DSSS-OFDM, 36 Mbps, 99pc duty cycle)	X	4.90	66.91	16.33	0.46	150.0	± 9.6 %
		Y	4.85	67.03	16.44		150.0	
		Z	4.79	66.87	16.26		150.0	
10569-AAA	IEEE 802.11g WiFi 2.4 GHz (DSSS-OFDM, 48 Mbps, 99pc duty cycle)	X	4.88	67.72	17.04	0.46	150.0	± 9.6 %
		Y	4.94	67.81	17.13		150.0	
		Z	4.89	67.71	17.00		150.0	
10570-AAA	IEEE 802.11g WiFi 2.4 GHz (DSSS-OFDM, 54 Mbps, 99pc duty cycle)	X	5.02	67.57	16.98	0.46	150.0	± 9.6 %
		Y	4.98	67.66	17.07		150.0	
		Z	4.92	67.54	16.93		150.0	
10571-AAA	IEEE 802.11b WiFi 2.4 GHz (DSSS, 1 Mbps, 90pc duty cycle)	X	1.12	64.14	15.50	0.46	130.0	± 9.6 %
		Y	1.13	64.44	15.80		130.0	
		Z	1.10	63.81	15.19		130.0	
10572-AAA	IEEE 802.11b WiFi 2.4 GHz (DSSS, 2 Mbps, 90pc duty cycle)	X	1.13	64.72	15.87	0.46	130.0	± 9.6 %
		Y	1.14	65.04	16.18		130.0	
		Z	1.11	64.34	15.54		130.0	
10573-AAA	IEEE 802.11b WiFi 2.4 GHz (DSSS, 5.5 Mbps, 90pc duty cycle)	X	1.81	85.29	23.32	0.46	130.0	± 9.6 %
		Y	2.55	92.11	26.05		130.0	
		Z	1.29	78.47	21.09		130.0	
10574-AAA	IEEE 802.11b WiFi 2.4 GHz (DSSS, 11 Mbps, 90pc duty cycle)	X	1.25	70.93	19.11	0.46	130.0	± 9.6 %
		Y	1.28	71.80	19.61		130.0	
		Z	1.18	69.77	18.42		130.0	

Certificate No: EX3-7461\_May17

Page 33 of 38

EX3DV4- SN:7461

May 26, 2017

10575-AAA	IEEE 802.11g WiFi 2.4 GHz (DSSS-OFDM, 6 Mbps, 90pc duty cycle)	X	4.67	66.52	16.38	0.46	130.0	± 9.6 %
		Y	4.63	66.82	16.46		130.0	
		Z	4.58	66.51	16.31		130.0	
10576-AAA	IEEE 802.11g WiFi 2.4 GHz (DSSS-OFDM, 9 Mbps, 90pc duty cycle)	X	4.69	66.69	16.45	0.46	130.0	± 9.6 %
		Y	4.66	66.80	16.54		130.0	
		Z	4.61	66.69	16.39		130.0	
10577-AAA	IEEE 802.11g WiFi 2.4 GHz (DSSS-OFDM, 12 Mbps, 90pc duty cycle)	X	4.91	67.01	16.64	0.46	130.0	± 9.6 %
		Y	4.86	67.09	16.71		130.0	
		Z	4.81	66.98	16.56		130.0	
10578-AAA	IEEE 802.11g WiFi 2.4 GHz (DSSS-OFDM, 18 Mbps, 90pc duty cycle)	X	4.81	67.20	16.76	0.46	130.0	± 9.6 %
		Y	4.76	67.27	16.83		130.0	
		Z	4.71	67.15	16.68		130.0	
10579-AAA	IEEE 802.11g WiFi 2.4 GHz (DSSS-OFDM, 24 Mbps, 90pc duty cycle)	X	4.56	66.42	16.01	0.46	130.0	± 9.6 %
		Y	4.51	66.50	16.09		130.0	
		Z	4.45	66.33	15.91		130.0	
10580-AAA	IEEE 802.11g WiFi 2.4 GHz (DSSS-OFDM, 36 Mbps, 90pc duty cycle)	X	4.61	66.42	16.01	0.46	130.0	± 9.6 %
		Y	4.56	66.53	16.11		130.0	
		Z	4.50	66.37	15.93		130.0	
10581-AAA	IEEE 802.11g WiFi 2.4 GHz (DSSS-OFDM, 48 Mbps, 90pc duty cycle)	X	4.70	67.22	16.68	0.46	130.0	± 9.6 %
		Y	4.66	67.30	16.76		130.0	
		Z	4.60	67.17	16.61		130.0	
10582-AAA	IEEE 802.11g WiFi 2.4 GHz (DSSS-OFDM, 54 Mbps, 90pc duty cycle)	X	4.51	66.15	15.79	0.46	130.0	± 9.6 %
		Y	4.46	66.25	15.88		130.0	
		Z	4.39	66.07	15.68		130.0	
10583-AAA	IEEE 802.11a/h WiFi 5 GHz (OFDM, 6 Mbps, 90pc duty cycle)	X	4.67	66.52	16.39	0.46	130.0	± 9.6 %
		Y	4.63	66.62	16.46		130.0	
		Z	4.58	66.51	16.31		130.0	
10584-AAA	IEEE 802.11a/h WiFi 5 GHz (OFDM, 9 Mbps, 90pc duty cycle)	X	4.69	66.69	16.45	0.46	130.0	± 9.6 %
		Y	4.66	66.80	16.54		130.0	
		Z	4.61	66.69	16.39		130.0	
10585-AAA	IEEE 802.11a/h WiFi 5 GHz (OFDM, 12 Mbps, 90pc duty cycle)	X	4.91	67.01	16.64	0.46	130.0	± 9.6 %
		Y	4.86	67.09	16.71		130.0	
		Z	4.81	66.98	16.56		130.0	
10586-AAA	IEEE 802.11a/h WiFi 5 GHz (OFDM, 18 Mbps, 90pc duty cycle)	X	4.81	67.20	16.76	0.46	130.0	± 9.6 %
		Y	4.76	67.27	16.83		130.0	
		Z	4.71	67.15	16.68		130.0	
10587-AAA	IEEE 802.11a/h WiFi 5 GHz (OFDM, 24 Mbps, 90pc duty cycle)	X	4.56	66.42	16.01	0.46	130.0	± 9.6 %
		Y	4.51	66.50	16.09		130.0	
		Z	4.45	66.33	15.91		130.0	
10588-AAA	IEEE 802.11a/h WiFi 5 GHz (OFDM, 36 Mbps, 90pc duty cycle)	X	4.61	66.42	16.01	0.46	130.0	± 9.6 %
		Y	4.56	66.53	16.11		130.0	
		Z	4.50	66.37	15.93		130.0	
10589-AAA	IEEE 802.11a/h WiFi 5 GHz (OFDM, 48 Mbps, 90pc duty cycle)	X	4.70	67.22	16.68	0.46	130.0	± 9.6 %
		Y	4.66	67.30	16.76		130.0	
		Z	4.60	67.17	16.61		130.0	
10590-AAA	IEEE 802.11a/h WiFi 5 GHz (OFDM, 54 Mbps, 90pc duty cycle)	X	4.51	66.15	15.79	0.46	130.0	± 9.6 %
		Y	4.46	66.25	15.88		130.0	
		Z	4.39	66.07	15.68		130.0	

Certificate No: EX3-7461\_May17

Page 34 of 38

EX3DV4- SN:7461

May 25, 2017

10591-AAA	IEEE 802.11n (HT Mixed, 20MHz, MCS0, 90pc duty cycle)	X	4.82	66.60	16.49	0.46	130.0	± 9.6 %
		Y	4.78	66.69	16.57		130.0	
		Z	4.74	66.59	16.43		130.0	
10592-AAA	IEEE 802.11n (HT Mixed, 20MHz, MCS1, 90pc duty cycle)	X	4.99	66.94	16.62	0.46	130.0	± 9.6 %
		Y	4.94	67.03	16.70		130.0	
		Z	4.88	66.92	16.56		130.0	
10593-AAA	IEEE 802.11n (HT Mixed, 20MHz, MCS2, 90pc duty cycle)	X	4.91	66.85	16.50	0.46	130.0	± 9.6 %
		Y	4.86	66.93	16.58		130.0	
		Z	4.80	66.81	16.43		130.0	
10594-AAA	IEEE 802.11n (HT Mixed, 20MHz, MCS3, 90pc duty cycle)	X	4.96	67.02	16.66	0.46	130.0	± 9.6 %
		Y	4.91	67.10	16.74		130.0	
		Z	4.86	66.99	16.59		130.0	
10595-AAA	IEEE 802.11n (HT Mixed, 20MHz, MCS4, 90pc duty cycle)	X	4.93	66.97	16.55	0.46	130.0	± 9.6 %
		Y	4.88	67.05	16.63		130.0	
		Z	4.82	66.93	16.48		130.0	
10596-AAA	IEEE 802.11n (HT Mixed, 20MHz, MCS5, 90pc duty cycle)	X	4.86	66.96	16.54	0.46	130.0	± 9.6 %
		Y	4.81	67.04	16.63		130.0	
		Z	4.78	66.91	16.47		130.0	
10597-AAA	IEEE 802.11n (HT Mixed, 20MHz, MCS6, 90pc duty cycle)	X	4.81	66.86	16.43	0.46	130.0	± 9.6 %
		Y	4.76	66.94	16.50		130.0	
		Z	4.70	66.80	16.34		130.0	
10598-AAA	IEEE 802.11n (HT Mixed, 20MHz, MCS7, 90pc duty cycle)	X	4.80	67.14	16.72	0.46	130.0	± 9.6 %
		Y	4.75	67.19	16.78		130.0	
		Z	4.69	67.06	16.63		130.0	
10599-AAA	IEEE 802.11n (HT Mixed, 40MHz, MCS0, 90pc duty cycle)	X	5.49	67.16	16.66	0.46	130.0	± 9.6 %
		Y	5.46	67.23	16.77		130.0	
		Z	5.40	67.10	16.63		130.0	
10600-AAA	IEEE 802.11n (HT Mixed, 40MHz, MCS1, 90pc duty cycle)	X	5.64	67.60	16.87	0.46	130.0	± 9.6 %
		Y	5.58	67.61	16.93		130.0	
		Z	5.53	67.49	16.80		130.0	
10601-AAA	IEEE 802.11n (HT Mixed, 40MHz, MCS2, 90pc duty cycle)	X	5.52	67.33	16.75	0.46	130.0	± 9.6 %
		Y	5.47	67.39	16.83		130.0	
		Z	5.42	67.26	16.70		130.0	
10602-AAA	IEEE 802.11n (HT Mixed, 40MHz, MCS3, 90pc duty cycle)	X	5.60	67.30	16.65	0.46	130.0	± 9.6 %
		Y	5.57	67.40	16.75		130.0	
		Z	5.52	67.31	16.64		130.0	
10603-AAA	IEEE 802.11n (HT Mixed, 40MHz, MCS4, 90pc duty cycle)	X	5.70	67.68	16.96	0.46	130.0	± 9.6 %
		Y	5.65	67.72	17.05		130.0	
		Z	5.60	67.60	16.92		130.0	
10604-AAA	IEEE 802.11n (HT Mixed, 40MHz, MCS5, 90pc duty cycle)	X	5.49	67.11	16.66	0.46	130.0	± 9.6 %
		Y	5.46	67.20	16.78		130.0	
		Z	5.44	67.17	16.69		130.0	
10605-AAA	IEEE 802.11n (HT Mixed, 40MHz, MCS6, 90pc duty cycle)	X	5.59	67.40	16.82	0.46	130.0	± 9.6 %
		Y	5.57	67.51	16.93		130.0	
		Z	5.52	67.39	16.79		130.0	
10606-AAA	IEEE 802.11n (HT Mixed, 40MHz, MCS7, 90pc duty cycle)	X	5.37	66.86	16.41	0.46	130.0	± 9.6 %
		Y	5.31	66.85	16.46		130.0	
		Z	5.26	66.70	16.30		130.0	

Certificate No: EX3-7461\_May17

Page 35 of 38

EX3DV4- SN:7461

May 26, 2017

10607-AAA	IEEE 802.11ac WiFi (20MHz, MCS0, 90pc duty cycle)	X	4.66	65.92	16.12	0.46	130.0	± 9.6 %
		Y	4.63	66.03	16.21		130.0	
		Z	4.58	65.92	16.06		130.0	
10608-AAA	IEEE 802.11ac WiFi (20MHz, MCS1, 90pc duty cycle)	X	4.86	66.34	16.28	0.46	130.0	± 9.6 %
		Y	4.81	66.44	16.37		130.0	
		Z	4.75	66.31	16.22		130.0	
10609-AAA	IEEE 802.11ac WiFi (20MHz, MCS2, 90pc duty cycle)	X	4.74	66.18	16.12	0.46	130.0	± 9.6 %
		Y	4.70	66.28	16.21		130.0	
		Z	4.64	66.14	16.05		130.0	
10610-AAA	IEEE 802.11ac WiFi (20MHz, MCS3, 90pc duty cycle)	X	4.80	66.35	16.29	0.46	130.0	± 9.6 %
		Y	4.75	66.44	16.37		130.0	
		Z	4.69	66.31	16.22		130.0	
10611-AAA	IEEE 802.11ac WiFi (20MHz, MCS4, 90pc duty cycle)	X	4.71	66.15	16.13	0.46	130.0	± 9.6 %
		Y	4.67	66.24	16.21		130.0	
		Z	4.61	66.10	16.05		130.0	
10612-AAA	IEEE 802.11ac WiFi (20MHz, MCS5, 90pc duty cycle)	X	4.72	66.29	16.16	0.46	130.0	± 9.6 %
		Y	4.67	66.39	16.25		130.0	
		Z	4.61	66.23	16.09		130.0	
10613-AAA	IEEE 802.11ac WiFi (20MHz, MCS6, 90pc duty cycle)	X	4.73	66.19	16.05	0.46	130.0	± 9.6 %
		Y	4.68	66.27	16.14		130.0	
		Z	4.61	66.10	15.96		130.0	
10614-AAA	IEEE 802.11ac WiFi (20MHz, MCS7, 90pc duty cycle)	X	4.67	66.41	16.31	0.46	130.0	± 9.6 %
		Y	4.63	66.49	16.39		130.0	
		Z	4.57	66.33	16.23		130.0	
10615-AAA	IEEE 802.11ac WiFi (20MHz, MCS8, 90pc duty cycle)	X	4.71	65.94	15.88	0.46	130.0	± 9.6 %
		Y	4.66	66.05	15.98		130.0	
		Z	4.60	65.90	15.81		130.0	
10616-AAA	IEEE 802.11ac WiFi (40MHz, MCS0, 90pc duty cycle)	X	5.31	66.45	16.32	0.46	130.0	± 9.6 %
		Y	5.28	66.50	16.39		130.0	
		Z	5.23	66.38	16.26		130.0	
10617-AAA	IEEE 802.11ac WiFi (40MHz, MCS1, 90pc duty cycle)	X	5.37	66.56	16.34	0.46	130.0	± 9.6 %
		Y	5.34	66.67	16.45		130.0	
		Z	5.29	66.55	16.32		130.0	
10618-AAA	IEEE 802.11ac WiFi (40MHz, MCS2, 90pc duty cycle)	X	5.26	66.62	16.39	0.46	130.0	± 9.6 %
		Y	5.23	66.69	16.47		130.0	
		Z	5.18	66.57	16.34		130.0	
10619-AAA	IEEE 802.11ac WiFi (40MHz, MCS3, 90pc duty cycle)	X	5.28	66.43	16.22	0.46	130.0	± 9.6 %
		Y	5.24	66.48	16.30		130.0	
		Z	5.19	66.34	16.16		130.0	
10620-AAA	IEEE 802.11ac WiFi (40MHz, MCS4, 90pc duty cycle)	X	5.39	66.50	16.31	0.46	130.0	± 9.6 %
		Y	5.34	66.52	16.37		130.0	
		Z	5.28	66.39	16.23		130.0	
10621-AAA	IEEE 802.11ac WiFi (40MHz, MCS5, 90pc duty cycle)	X	5.38	66.62	16.50	0.46	130.0	± 9.6 %
		Y	5.34	66.67	16.57		130.0	
		Z	5.29	66.56	16.45		130.0	
10622-AAA	IEEE 802.11ac WiFi (40MHz, MCS6, 90pc duty cycle)	X	5.38	66.75	16.55	0.46	130.0	± 9.6 %
		Y	5.35	66.83	16.64		130.0	
		Z	5.30	66.71	16.51		130.0	

Certificate No: EX3-7461\_May17

Page 38 of 38



EX3DV4- SN:7461

May 26, 2017

10623-AAA	IEEE 802.11ac WiFi (40MHz, MCS7, 90pc duty cycle)	X	5.26	66.27	16.18	0.46	130.0	± 9.6 %
		Y	5.22	66.34	16.27		130.0	
		Z	5.17	66.21	16.13		130.0	
10624-AAA	IEEE 802.11ac WiFi (40MHz, MCS8, 90pc duty cycle)	X	5.45	66.48	16.35	0.46	130.0	± 9.6 %
		Y	5.42	66.54	16.43		130.0	
		Z	5.38	66.42	16.30		130.0	
10625-AAA	IEEE 802.11ac WiFi (40MHz, MCS9, 90pc duty cycle)	X	5.84	67.51	16.91	0.46	130.0	± 9.6 %
		Y	5.78	67.51	16.96		130.0	
		Z	5.69	67.27	16.77		130.0	
10626-AAA	IEEE 802.11ac WiFi (80MHz, MCS0, 90pc duty cycle)	X	5.59	66.90	16.26	0.46	130.0	± 9.6 %
		Y	5.57	66.55	16.34		130.0	
		Z	5.53	66.44	16.22		130.0	
10627-AAA	IEEE 802.11ac WiFi (80MHz, MCS1, 90pc duty cycle)	X	5.83	67.03	16.48	0.46	130.0	± 9.6 %
		Y	5.81	67.11	16.58		130.0	
		Z	5.76	66.98	16.45		130.0	
10628-AAA	IEEE 802.11ac WiFi (80MHz, MCS2, 90pc duty cycle)	X	5.64	66.61	16.21	0.46	130.0	± 9.6 %
		Y	5.60	66.64	16.28		130.0	
		Z	5.55	66.49	16.13		130.0	
10629-AAA	IEEE 802.11ac WiFi (80MHz, MCS3, 90pc duty cycle)	X	5.73	66.70	16.24	0.46	130.0	± 9.6 %
		Y	5.68	66.69	16.29		130.0	
		Z	5.62	66.54	16.15		130.0	
10630-AAA	IEEE 802.11ac WiFi (80MHz, MCS4, 90pc duty cycle)	X	6.18	68.22	17.00	0.46	130.0	± 9.6 %
		Y	6.11	68.17	17.03		130.0	
		Z	6.00	67.87	16.82		130.0	
10631-AAA	IEEE 802.11ac WiFi (80MHz, MCS5, 90pc duty cycle)	X	6.10	68.11	17.15	0.46	130.0	± 9.6 %
		Y	6.02	68.02	17.16		130.0	
		Z	5.94	67.83	17.00		130.0	
10632-AAA	IEEE 802.11ac WiFi (80MHz, MCS6, 90pc duty cycle)	X	5.81	67.14	16.68	0.46	130.0	± 9.6 %
		Y	5.78	67.19	16.76		130.0	
		Z	5.74	67.09	16.65		130.0	
10633-AAA	IEEE 802.11ac WiFi (80MHz, MCS7, 90pc duty cycle)	X	5.71	66.80	16.33	0.46	130.0	± 9.6 %
		Y	5.67	66.81	16.40		130.0	
		Z	5.62	66.69	16.27		130.0	
10634-AAA	IEEE 802.11ac WiFi (80MHz, MCS8, 90pc duty cycle)	X	5.70	66.85	16.42	0.46	130.0	± 9.6 %
		Y	5.66	66.85	16.48		130.0	
		Z	5.60	66.73	16.35		130.0	
10635-AAA	IEEE 802.11ac WiFi (80MHz, MCS9, 90pc duty cycle)	X	5.57	66.12	15.77	0.46	130.0	± 9.6 %
		Y	5.53	66.14	15.84		130.0	
		Z	5.47	65.98	15.69		130.0	
10636-AAA	IEEE 1602.11ac WiFi (160MHz, MCS0, 90pc duty cycle)	X	6.00	66.88	16.35	0.46	130.0	± 9.6 %
		Y	5.98	66.91	16.42		130.0	
		Z	5.94	66.80	16.30		130.0	
10637-AAA	IEEE 1602.11ac WiFi (160MHz, MCS1, 90pc duty cycle)	X	6.16	67.25	16.51	0.46	130.0	± 9.6 %
		Y	6.14	67.29	16.59		130.0	
		Z	6.09	67.17	16.47		130.0	
10638-AAA	IEEE 1602.11ac WiFi (160MHz, MCS2, 90pc duty cycle)	X	6.16	67.22	16.48	0.46	130.0	± 9.6 %
		Y	6.14	67.26	16.55		130.0	
		Z	6.09	67.14	16.43		130.0	

Certificate No: EX3-7461\_May17

Page 37 of 38

EX3DV4-SN:7461

May 28, 2017

10639-AAA	IEEE 1602.11ac WiFi (160MHz, MCS3, 90pc duty cycle)	X	6.15	67.21	16.52	0.46	130.0	± 9.6 %
		Y	6.12	67.22	16.58		130.0	
		Z	6.07	67.09	16.45		130.0	
10640-AAA	IEEE 1602.11ac WiFi (160MHz, MCS4, 90pc duty cycle)	X	6.16	67.22	16.46	0.46	130.0	± 9.6 %
		Y	6.12	67.22	16.52		130.0	
		Z	6.07	67.08	16.38		130.0	
10641-AAA	IEEE 1602.11ac WiFi (160MHz, MCS5, 90pc duty cycle)	X	6.18	67.05	16.40	0.46	130.0	± 9.6 %
		Y	6.16	67.12	16.48		130.0	
		Z	6.12	67.01	16.37		130.0	
10642-AAA	IEEE 1602.11ac WiFi (160MHz, MCS6, 90pc duty cycle)	X	6.25	67.40	16.75	0.46	130.0	± 9.6 %
		Y	6.21	67.40	16.80		130.0	
		Z	6.16	67.29	16.68		130.0	
10643-AAA	IEEE 1602.11ac WiFi (160MHz, MCS7, 90pc duty cycle)	X	6.07	67.03	16.45	0.46	130.0	± 9.6 %
		Y	6.04	67.06	16.53		130.0	
		Z	5.99	66.94	16.40		130.0	
10644-AAA	IEEE 1602.11ac WiFi (160MHz, MCS8, 90pc duty cycle)	X	6.26	67.61	16.77	0.46	130.0	± 9.6 %
		Y	6.20	67.56	16.80		130.0	
		Z	6.13	67.37	16.63		130.0	
10645-AAA	IEEE 1602.11ac WiFi (160MHz, MCS9, 90pc duty cycle)	X	6.69	68.43	17.12	0.46	130.0	± 9.6 %
		Y	6.53	68.13	17.03		130.0	
		Z	6.34	67.62	16.72		130.0	
10646-AAC	LTE-TDD (SC-FDMA, 1 RB, 5 MHz, QPSK, UL Subframe=2,7)	X	9.94	91.63	29.30	9.30	60.0	± 9.6 %
		Y	9.79	92.68	29.94		60.0	
		Z	8.95	90.91	29.39		60.0	
10647-AAB	LTE-TDD (SC-FDMA, 1 RB, 20 MHz, QPSK, UL Subframe=2,7)	X	9.03	90.23	29.93	9.30	60.0	± 9.6 %
		Y	8.82	91.11	29.52		60.0	
		Z	8.03	89.26	28.93		60.0	
10648-AAA	CDMA2000 (1x Advanced)	X	0.81	65.66	12.50	0.00	150.0	± 9.6 %
		Y	0.83	66.44	12.69		150.0	
		Z	0.71	64.34	11.20		150.0	

<sup>1</sup> Uncertainty is determined using the max. deviation from linear response applying rectangular distribution and is expressed for the square of the field value.

**Calibration Laboratory of  
 Schmid & Partner  
 Engineering AG**  
 Zeughausstrasse 43, 8004 Zurich, Switzerland



**S** Schweizerischer Kalibrierdienst  
**C** Service suisse d'étalonnage  
**S** Servizio svizzero di taratura  
**S** Swiss Calibration Service

Accredited by the Swiss Accreditation Service (SAS)  
 The Swiss Accreditation Service is one of the signatories to the EA  
 Multilateral Agreement for the recognition of calibration certificates

Accreditation No.: **SCS 0108**

Client **AT4 Wireless**

Certificate No: **D2450V2-756\_Jul15**

## CALIBRATION CERTIFICATE

Object: **D2450V2 - SN:756**

Calibration procedure(s): **QA CAL-05.v9  
 Calibration procedure for dipole validation kits above 700 MHz**

Calibration date: **July 08, 2015**

This calibration certificate documents the traceability to national standards, which realize the physical units of measurements (SI).  
 The measurements and the uncertainties with confidence probability are given on the following pages and are part of the certificate.

All calibrations have been conducted in the closed laboratory facility: environment temperature ( $22 \pm 3$ )°C and humidity < 70%.

Calibration Equipment used (M&TE critical for calibration)

Primary Standards	ID #	Cal Date (Certificate No.)	Scheduled Calibration
Power meter EPM-442A	GB37480704	07-Oct-14 (No. 217-02020)	Oct-15
Power sensor HP 8481A	US37292783	07-Oct-14 (No. 217-02020)	Oct-15
Power sensor HP 8481A	MY41092317	07-Oct-14 (No. 217-02021)	Oct-15
Reference 20 dB Attenuator	SN: 5058 (20k)	01-Apr-15 (No. 217-02131)	Mar-16
Type-N mismatch combination	SN: 5047.2 / 06327	01-Apr-15 (No. 217-02134)	Mar-16
Reference Probe ES3DV3	SN: 3205	30-Dec-14 (No. ES3-3205_Dec14)	Dec-15
DAE4	SN: 601	18-Aug-14 (No. DAE4-601_Aug14)	Aug-15
Secondary Standards	ID #	Check Date (in house)	Scheduled Check
RF generator R&S SMT-06	100005	04-Aug-99 (in house check Oct-13)	In house check: Oct-16
Network Analyzer HP 8753E	US37390585 S4206	18-Oct-01 (in house check Oct-14)	In house check: Oct-15

	Name	Function	Signature
Calibrated by:	Jeton Kastrati	Laboratory Technician	
Approved by:	Katja Pokovic	Technical Manager	

Issued: July 9, 2015

This calibration certificate shall not be reproduced except in full without written approval of the laboratory.

**Calibration Laboratory of  
Schmid & Partner  
Engineering AG**  
Zeughausstrasse 43, 8004 Zurich, Switzerland



**S** Schweizerischer Kalibrierdienst  
**C** Service suisse d'étalonnage  
**S** Servizio svizzero di taratura  
**S** Swiss Calibration Service

Accredited by the Swiss Accreditation Service (SAS)  
The Swiss Accreditation Service is one of the signatories to the EA  
Multilateral Agreement for the recognition of calibration certificates

Accreditation No.: **SCS 0108**

**Glossary:**

TSL	tissue simulating liquid
ConvF	sensitivity in TSL / NORM x,y,z
N/A	not applicable or not measured

**Calibration is Performed According to the Following Standards:**

- IEEE Std 1528-2013, "IEEE Recommended Practice for Determining the Peak Spatial-Averaged Specific Absorption Rate (SAR) in the Human Head from Wireless Communications Devices: Measurement Techniques", June 2013
- IEC 62209-1, "Procedure to measure the Specific Absorption Rate (SAR) for hand-held devices used in close proximity to the ear (frequency range of 300 MHz to 3 GHz)", February 2005
- IEC 62209-2, "Procedure to determine the Specific Absorption Rate (SAR) for wireless communication devices used in close proximity to the human body (frequency range of 30 MHz to 6 GHz)", March 2010
- KDB 865664, "SAR Measurement Requirements for 100 MHz to 6 GHz"

**Additional Documentation:**

- DASY4/5 System Handbook

**Methods Applied and Interpretation of Parameters:**

- Measurement Conditions:* Further details are available from the Validation Report at the end of the certificate. All figures stated in the certificate are valid at the frequency indicated.
- Antenna Parameters with TSL:* The dipole is mounted with the spacer to position its feed point exactly below the center marking of the flat phantom section, with the arms oriented parallel to the body axis.
- Feed Point Impedance and Return Loss:* These parameters are measured with the dipole positioned under the liquid filled phantom. The impedance stated is transformed from the measurement at the SMA connector to the feed point. The Return Loss ensures low reflected power. No uncertainty required.
- Electrical Delay:* One-way delay between the SMA connector and the antenna feed point. No uncertainty required.
- SAR measured:* SAR measured at the stated antenna input power.
- SAR normalized:* SAR as measured, normalized to an input power of 1 W at the antenna connector.
- SAR for nominal TSL parameters:* The measured TSL parameters are used to calculate the nominal SAR result.

The reported uncertainty of measurement is stated as the standard uncertainty of measurement multiplied by the coverage factor  $k=2$ , which for a normal distribution corresponds to a coverage probability of approximately 95%.

### Measurement Conditions

DASY system configuration, as far as not given on page 1.

DASY Version	DASY5	V52.8.8
Extrapolation	Advanced Extrapolation	
Phantom	Modular Flat Phantom	
Distance Dipole Center - TSL	10 mm	with Spacer
Zoom Scan Resolution	dx, dy, dz = 5 mm	
Frequency	2450 MHz ± 1 MHz	

### Head TSL parameters

The following parameters and calculations were applied.

	Temperature	Permittivity	Conductivity
Nominal Head TSL parameters	22.0 °C	39.2	1.80 mho/m
Measured Head TSL parameters	(22.0 ± 0.2) °C	37.9 ± 6 %	1.88 mho/m ± 6 %
Head TSL temperature change during test	< 0.5 °C	----	----

### SAR result with Head TSL

SAR averaged over 1 cm <sup>3</sup> (1 g) of Head TSL	Condition	
SAR measured	250 mW input power	13.8 W/kg
SAR for nominal Head TSL parameters	normalized to 1W	53.7 W/kg ± 17.0 % (k=2)

SAR averaged over 10 cm <sup>3</sup> (10 g) of Head TSL	condition	
SAR measured	250 mW input power	6.46 W/kg
SAR for nominal Head TSL parameters	normalized to 1W	25.4 W/kg ± 16.5 % (k=2)

### Body TSL parameters

The following parameters and calculations were applied.

	Temperature	Permittivity	Conductivity
Nominal Body TSL parameters	22.0 °C	52.7	1.95 mho/m
Measured Body TSL parameters	(22.0 ± 0.2) °C	52.4 ± 6 %	2.03 mho/m ± 6 %
Body TSL temperature change during test	< 0.5 °C	----	----

### SAR result with Body TSL

SAR averaged over 1 cm <sup>3</sup> (1 g) of Body TSL	Condition	
SAR measured	250 mW input power	13.3 W/kg
SAR for nominal Body TSL parameters	normalized to 1W	52.1 W/kg ± 17.0 % (k=2)

SAR averaged over 10 cm <sup>3</sup> (10 g) of Body TSL	condition	
SAR measured	250 mW input power	6.17 W/kg
SAR for nominal Body TSL parameters	normalized to 1W	24.4 W/kg ± 16.5 % (k=2)

## Appendix (Additional assessments outside the scope of SCS 0108)

### Antenna Parameters with Head TSL

Impedance, transformed to feed point	55.9 $\Omega$ + 2.7 j $\Omega$
Return Loss	- 24.3 dB

### Antenna Parameters with Body TSL

Impedance, transformed to feed point	52.4 $\Omega$ + 4.3 j $\Omega$
Return Loss	- 26.4 dB

### General Antenna Parameters and Design

Electrical Delay (one direction)	1.157 ns
----------------------------------	----------

After long term use with 100W radiated power, only a slight warming of the dipole near the feedpoint can be measured.

The dipole is made of standard semirigid coaxial cable. The center conductor of the feeding line is directly connected to the second arm of the dipole. The antenna is therefore short-circuited for DC-signals. On some of the dipoles, small end caps are added to the dipole arms in order to improve matching when loaded according to the position as explained in the "Measurement Conditions" paragraph. The SAR data are not affected by this change. The overall dipole length is still according to the Standard.

No excessive force must be applied to the dipole arms, because they might bend or the soldered connections near the feedpoint may be damaged.

### Additional EUT Data

Manufactured by	SPEAG
Manufactured on	April 22, 2004

## DASY5 Validation Report for Head TSL

Date: 08.07.2015

Test Laboratory: SPEAG, Zurich, Switzerland

**DUT: Dipole 2450 MHz; Type: D2450V2; Serial: D2450V2 - SN:756**

Communication System: UID 0 - CW; Frequency: 2450 MHz

Medium parameters used:  $f = 2450$  MHz;  $\sigma = 1.88$  S/m;  $\epsilon_r = 37.9$ ;  $\rho = 1000$  kg/m<sup>3</sup>

Phantom section: Flat Section

Measurement Standard: DASY5 (IEEE/IEC/ANSI C63.19-2011)

DASY52 Configuration:

- Probe: ES3DV3 - SN3205; ConvF(4.54, 4.54, 4.54); Calibrated: 30.12.2014;
- Sensor-Surface: 3mm (Mechanical Surface Detection)
- Electronics: DAE4 Sn601; Calibrated: 18.08.2014
- Phantom: Flat Phantom 5.0 (front); Type: QD000P50AA; Serial: 1001
- DASY52 52.8.8(1222); SEMCAD X 14.6.10(7331)

### Dipole Calibration for Head Tissue/Pin=250 mW, d=10mm/Zoom Scan (7x7x7)/Cube 0:

Measurement grid: dx=5mm, dy=5mm, dz=5mm

Reference Value = 101.3 V/m; Power Drift = 0.04 dB

Peak SAR (extrapolated) = 28.2 W/kg

**SAR(1 g) = 13.8 W/kg; SAR(10 g) = 6.46 W/kg**

Maximum value of SAR (measured) = 18.0 W/kg



0 dB = 18.0 W/kg = 12.55 dBW/kg

### Impedance Measurement Plot for Head TSL

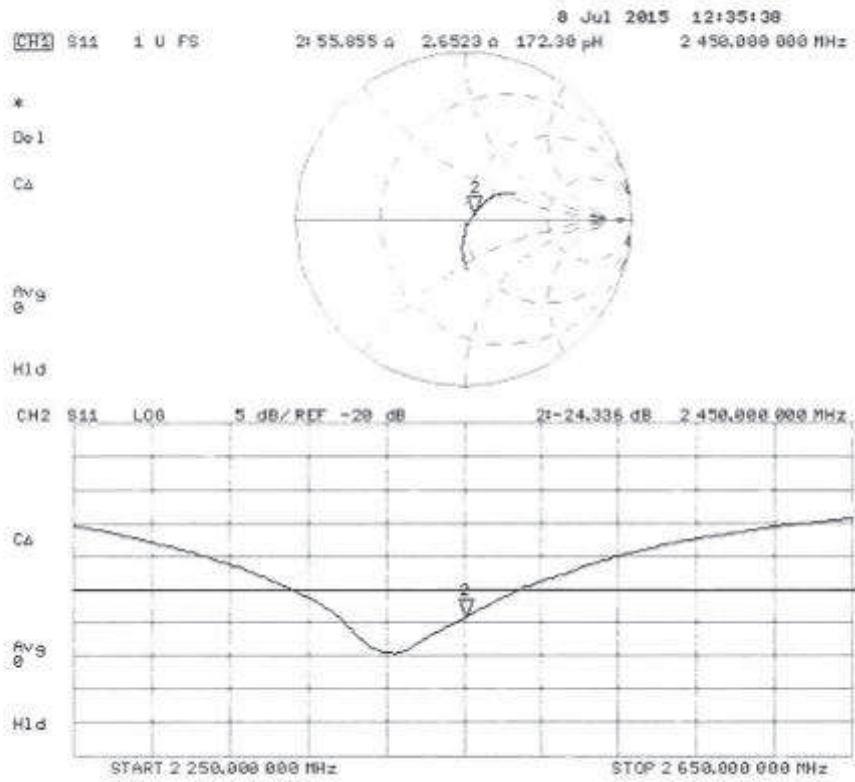



## DASY5 Validation Report for Body TSL

Date: 08.07.2015

Test Laboratory: SPEAG, Zurich, Switzerland

**DUT: Dipole 2450 MHz; Type: D2450V2; Serial: D2450V2 - SN:756**

Communication System: UID 0 - CW; Frequency: 2450 MHz

Medium parameters used:  $f = 2450$  MHz;  $\sigma = 2.03$  S/m;  $\epsilon_r = 52.4$ ;  $\rho = 1000$  kg/m<sup>3</sup>

Phantom section: Flat Section

Measurement Standard: DASY5 (IEEE/IEC/ANSI C63.19-2011)

DASY52 Configuration:

- Probe: ES3DV3 - SN3205; ConvF(4.32, 4.32, 4.32); Calibrated: 30.12.2014;
- Sensor-Surface: 3mm (Mechanical Surface Detection)
- Electronics: DAE4 Sn601; Calibrated: 18.08.2014
- Phantom: Flat Phantom 5.0 (back); Type: QD000P50AA; Serial: 1002
- DASY52 52.8.8(1222); SEMCAD X 14.6.10(7331)

### Dipole Calibration for Body Tissue/Pin=250 mW, d=10mm/Zoom Scan (7x7x7)/Cube 0:

Measurement grid: dx=5mm, dy=5mm, dz=5mm

Reference Value = 95.96 V/m; Power Drift = -0.00 dB

Peak SAR (extrapolated) = 27.4 W/kg

SAR(1 g) = 13.3 W/kg; SAR(10 g) = 6.17 W/kg

Maximum value of SAR (measured) = 17.6 W/kg

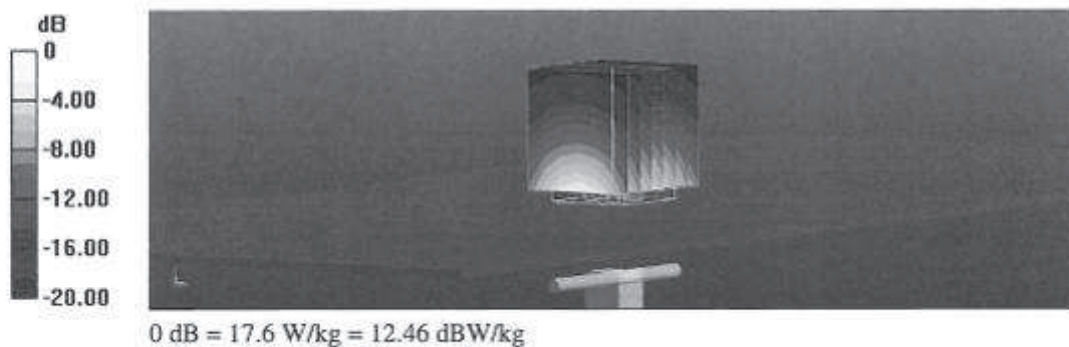

### Impedance Measurement Plot for Body TSL

