

Z-Card 210 Radio Part
Factory Tune-up Procedure 1.0

December 22,1999

Table of Contents

1.0 PURPOSE

2.0 SCOPE

3.0 RELATED DOCUMENTS

4.0 OVERVIEW

4.1 Introduction

4.2 Z-Card 210 Radio Reference Solution Architecture

5.0 FACTORY TUNE-UP PROCEDUES

5.1 TESTEQUIPMENT REQUTREMENT

5.2.1 INTRODUCTION

5.2.2 PROCEDURE

5.3 TUNING PROCEDURE

5.3.1 INTRODUCTION

5.3.2 PROCEDURE

6.0 Z-Card 210 RADIO PART DATA SHEET

1.0 Purpose

The purpose of this document is to provide the necessary information to allow a test person to tune-up a Z-Card 210 Radio part in conjunction with the baseband card.

2.0 Scope

This document will provide a top level description of the Z-Card 210 Radio Part. For the purposes of this factory tune-up procedure it will be assumed that the Z-Card 210 radio part is used with baseband card.

3.0 Related Documents

There are a number of related documents which are helpful when using this manual. They include the following

- a) Z-Card 210 CDPD User's Manual
- b) Topaz CDPD Radio Interface Chip Data Sheet
- c) CDPD System Specification, Book III
- d) Z-Card 210 Radio Circuitry Description 1.0

The Z-Card 210 CDPD User's Manual provides the necessary information to operate a CDPD-MES modem. The Topaz CDPD Radio Interface Chip Data Sheet provides same type of information for the Topaz CDPD Radio Interface. Book III of the CDPD System Specification provides the detailed requirements of the CDPD network system. The Z-Card 210 Radio Circuitry Description 1.0 provides information on the circuits relevant to FCC part 22 certification.

4.0 Overview

4.1 Introduction

Figure 4-1 shows the elements of the CDPD network. This network provides packetized data communications over the same channels used by the AMPS cellular voice system. It does this by using unused channels or channels dedicated to CDPD. See the CDPD Specification for more information.

The primary components are the MES (Mobile End System) the MDBS(Mobile Data Base Station) and the MDIS(Mobile Data Intermediate System). The M-ES is the only mobile component of the CDPD network. It uses a radio to communicate over the airlink interface to a MDBS. As the MES roams, hand-offs will occur between MDBSs.

Figure 4-1 CDPD Network

The MES communicates to both the MDBS and the MDIS but at different layers of the CDPD protocol. The MDIS is also connected to a wired backbone which can provide internet access, transportation to a corporate LAN, or another M-ES(with the help of another MDBS)

Z-Card 210 is a CDPD MES which will operate in such a CDPD network environment.

4.2 Z-Card 210 Radio Part Circuit Architecture

The Z-Card 210 radio part is the MES' transceiver portion of the CDPD Network. Figure 4-2 presents the block diagram of Z-Card 210 radio.

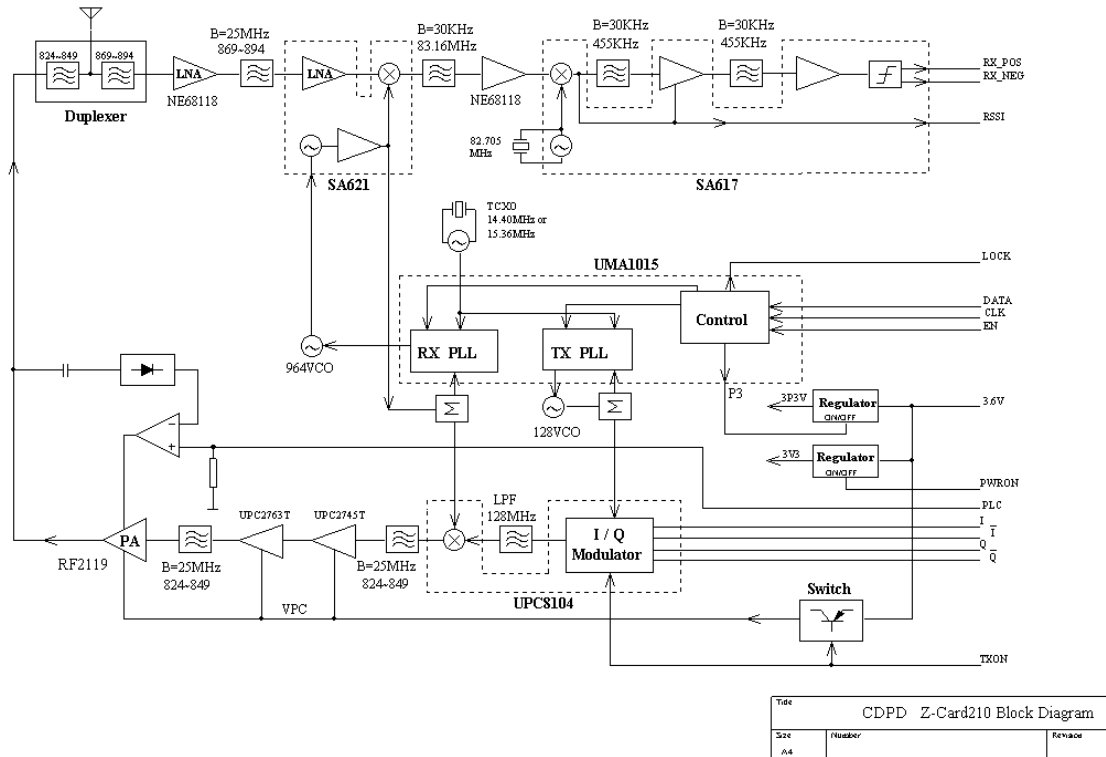

Figure 4-2 Z-Card 210 Radio Block Diagram

The radio transceiver provides full-duplex operation with a transmitter architecture employing vector modulation of an offset loop oscillator and a receiver utilizing a dual-conversion, heterodyne architecture. The radio is designed to meet CDPD specifications and to be FCC compliant . Within the context of the Z-Card 210 CDPD Reference Solution, the radio is controlled by the Ruby II Communications Processor. It also passes the signals to and from the Topaz radio interface IC, and transmits and receives radio signals to and from the MDDBS over the airlink interface . For further information see the Ruby II Communications Processor and Topaz CDPD Radio Interface IC Data Sheets.

The Z-Card 210 Radio part interface is shown in Figure 4-3 . The Z-Card 210 Radio provides vector controlled modulation. The Z-Card 210 radio interface has a radio On/Off Control which is controlled by the Topaz CDPD Radio Interface Chip Port registers. The Z-Card 210 radio TX Power is controlled by the Topaz CDPD Radio Interface Chip TX Power D/A .

A micro controller (Ruby) which resides in Z-Card 210 baseband PCMCIA card is used to control the Z-Card 210 radio channel select synthesizers with configuration and synthesizer commands.

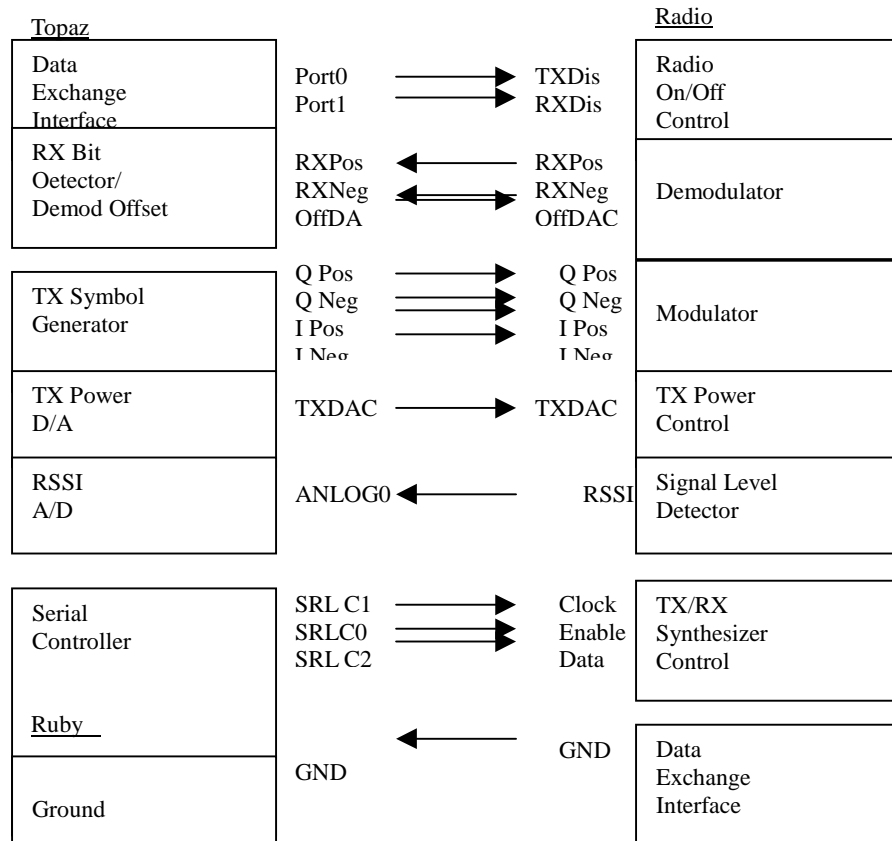

Figure 4-3 Z-Card 210 Radio Interface

5.0 Factory Tune-up procedures

All data taken should be recorded on a copy of sample data sheet in section 6.

5.1 Test Equipment Requirements

The following test equipment(or equivalents) are required to properly tune the Z-Card 210 Radio.

1. Tested Z-Card 210 baseband assembly with baseband/radio interface cable.
2. Personal computer with the RFTEST test software and PCMCIA prot.
3. HP E3610A DC power supply.
4. HP.8595E spectrum analyzer.
5. HP 8643A synthesized signal generator
6. HP 53131A universal counter w/option 010 high stability oven.
7. Fluke 87 RMS multimeter.
8. SMA compatible 10 dB 50 resistive attenuator.
9. Tektronix TDS 540A 4 channel digitizing oscilloscope.

5.2 Pre-tuning procedure

5.2.1 Introduction

This section describes the steps to take before the actual alignment of the radio should begin. The effort in this section is to visually inspect the assembled radio and measure the resistance between the three power supply positions and ground, and power on the radio to ensure proper power consumption.

5.2.2

1. Visually inspect the radio to verify all components have been installed.
2. Measure the resistance between the +3.6V supply input on J2 pin 1,3,5,7 and ground(pin 2,4,6,8).

Resistance J2, 1, 3,5,7 to GND ____ OHM
typically 2M OHM

3. Measure the resistance between synthesizers power and ground. ____ OHM

Resistance U5_4 to GND
typically = 1.9K OHM

4. Measure the resistance between the transceiver power and ground. ____ OHM

Resistance U4-4 to GND
typically = 955 OHM

5. If values in steps 2-4 are less than 200 OHM there may be a problem and the unit should not be powered on.

6. Power on the radio with the receive and the transmit circuitry selected and the transmitter inhibited (set J3-7 transmit control voltage=0V). Measure the supply current.

Supply Current ____ mA
Typically 50mA

5.3 Tuning Procedure

5.3.1 Introduction

This section describes the procedure required to manually align the transmitter and receiver circuitry. The 128.16 MHz VCO is used to drive the quadrature modulator circuit. It is necessary to tune the TCXO (U6) to align the 128.16 MHz VCO so that it will oscillate at 128.16 MHz with the proper tuning voltage at D2. D2 is varactor (voltage variable capacitor) that is used to automatically control the frequency of oscillation of the 128.16 MHz VCO. The transmitter accuracy is then measured following alignment of the 128.16 MHz VCO because this is a convenient time to make this measurement. The automatic power vs. control voltage curve is developed while in this set up also. The quadrature demodulator's tank circuit similarly needs manual tuning to get the center frequency of the discriminator close to final operation. Avaractor is then used to automatically make very fine adjustments.

5.3.2 Procedure

Transmitter alignment

1. Connect the antenna port of the radio to 10 dB resistive attenuator and then to a calibrated spectrum analyzer turned to 837.6 MHz with a span of 100kHz. Power on the radio. Tune the radio to channel 420. This sets the radio to receive at 882.6 MHz and transmit at 837.6 MHz.
2. Enable the transmitter with 0 second switching time, the power level set to 7, and the modulation set to alternating 1s and 0s. this will enable the transmitter to transmit at its lowest output power level with modulation that puts the carrier frequency at the center of the transmitted channel and with an output power level of +8 dBm +2dB/-4dB. **Note:** power measurement made with the spectrum analyzer will be 10 dB lower than actual power levels.
3. Vary control screw of TCXO (U6) until the measured frequency at TP 9 is 128.1600MHz.
4. Run the automated power vs. TXDAC control voltage routine. This varied the power amp control voltage, measures the output power of the transmitter and determines the best fit valued for the transmitter control voltages that meet the CDPD class 3 MES devices. These values are then saved to a file that is later downloaded into the memory of the baseband board that will be used with this radio.
5. Set the transmitter to pseudo-random data and transmit full power (level 2) and monitor the supply current.

Supply current mA
(typically 750 mA)

6. Change the transmit modulation to Vmid (no modulation), connect the antenna port to the frequency center and verify the output frequency accuracy is within 837.6MHz 2074Hz(2.5PPM). at room temperature the frequency should be specification over temperature and voltage variations.

Frequency MHz

6.0 Guide Radio Data Sheet

Date
Serial Number

Pre-tune Procedure

1. Visual inspection of components.(check)
2. Resistance J2-1,3,5,7 to GND(2,4,6,8). (typically=220k OHM)
3. Resistance U4-4 to GND. (typically=1.9k OHM)
4. Resistance U5-4 to GND. (typically=955 OHM)
5. Supply Current
RX , only (typically 50mA)

Truing Procedure

Transmitter Alignment

- 1.transmitter full power supply current. (typically=750mA) _____mA
- 2.frequency accuracy (837.6MHz 1000Hz). _____MHz