

***FCC Part 22 Subpart H***  
***EMI TEST REPORT***  
  
*of*

E.U.T. : CDPD

FCC ID. : M4Y-ZCARD210

MODEL : Z-Card210

Working Frequency : 824.010-848.970 MHz

*for*

APPLICANT : Z-COM, INC.

ADDRESS : 7F-2, NO. 9, PROSPERITY 1ST RD., SCIENCE-BASED  
INDUSTRIAL PARK, HSINCHU, TAIWAN, R.O.C.

Test Performed by

**ELECTRONICS TESTING CENTER, TAIWAN**  
NO. 8 LANE 29, WENMIMG ROAD,  
LOSHAN TSUN, KWEISHAN HSIANG,  
TAOYUAN, TAIWAN, R.O.C.

Tel:(03)3280026-32

Fax:(03)3280034

Report Number : ET88R-10-032

## **TEST REPORT CIRTIFICATION**

Applicant : Z-COM, INC.  
7F-2, NO. 9, PROSPERITY 1ST RD., SCIENCE-BASED INDUSTRIAL PARK,  
HSINCHU, TAIWAN, R.O.C.

Manufacturer : Z-COM, INC.  
7F-2, NO. 9, PROSPERITY 1ST RD., SCIENCE-BASED INDUSTRIAL PARK,  
HSINCHU, TAIWAN, R.O.C.

Description of EUT :

- a) Type of EUT : CDPD
- b) Trade Name : Z-COM
- c) Model No. : Z-Card210
- d) FCC ID : M4Y-ZCARD210
- e) Working Frequency : 824.040 to 848.97 MHz
- f) Power Supply : DC 5V From Notebook PC

Regulation Applied : FCC CFR 47 Part 22 Subpart H (1998)

I HEREBY CERTIFY THAT; The data shown in this report were made in accordance with the procedures given in ANSI C63.4 and EIA/IS-19-B, and the energy emitted by the device was founded to be within the limits applicable. I assume full responsibility for accuracy and completeness of these data.

Note : 1. The results of the testing report relate only to the items tested  
2. The testing report shall not be reproduced except in full, without the written approval of ETC

Issued Date : JAN. 14, 2000

Test Engineer : S. S. Liou  
( S. S. Liou )

Approve & Authorized Signer : Will Yauo  
Will Yauo, Supervisor  
EMI Test Site of ELECTRONICS  
TESTING CENTER, TAIWAN

<i>Table of Contents</i>	<i>Page</i>
<b>1. GENERAL INFORMATION .....</b>	<b>1</b>
1.1 PRODUCT DESCRIPTION.....	1
1.2 CHARACTERISTICS OF DEVICE .....	1
1.3 TEST METHODOLOGY.....	1
1.4 TEST FACILITY.....	1
<b>2. REQUIREMENTS OF PROVISIONS.....</b>	<b>2</b>
2.1 DEFINITION .....	2
2.2 FREQUENCIES AVAILABLE.....	2
2.3 REQUIREMENTS FOR TYPE ACCEPTANCE .....	2
2.4 LABELING REQUIREMENT .....	3
2.5 USER INFORMATION.....	3
<b>3. OUTPUT POWER MEASUREMENT.....</b>	<b>4</b>
3.1 PROVISION APPLICABLE.....	4
3.2 MEASUREMENT PROCEDURE .....	4
3.3 TEST DATA .....	7
3.3 RESULT CALCULATION.....	8
3.4 OUTPUT POWER TEST EQUIPMENT .....	8
<b>4. MODULATION CHARACTERISTICS .....</b>	<b>9</b>
4.1 PROVISIONS APPLICABLE .....	9
4.2 MEASUREMENT METHOD.....	9
4.3 MEASUREMENT INSTRUMENT.....	10
4.4 MEASUREMENT RESULT .....	11
<b>5. OCCUPIED BANDWIDTH OF EMISSION.....</b>	<b>12</b>
5.1 PROVISIONS APPLICABLE .....	12
5.2 MEASUREMENT METHOD.....	12
5.3 OCCUPIED BANDWIDTH TEST EQUIPMENT .....	13
5.4 BANDWIDTH MEASURED .....	13
<b>6. SPURIOUS EMISSIONS AT ANTENNA TERMINALS.....</b>	<b>14</b>
6.1 PROVISIONS APPLICABLE .....	14
6.2 MEASUREMENT PROCEDURE .....	15
6.3 MEASUREMENT EQUIPMENT .....	15
6.4 MEASUREMENT DATA .....	16
<b>7. FIELD STRENGTH OF EMISSION .....</b>	<b>19</b>
7.1 PROVISIONS APPLICABLE .....	19
7.2 MEASUREMENT PROCEDURE .....	19
7.3 MEASURING INSTRUMENT .....	21
7.4 MEASURING DATA.....	22
7.5 DETAILS OF TESTED SYSTEM .....	26
7.6 RADIATION SETUP PHOTOS.....	27
<b>8. FREQUENCY STABILITY MEASUREMENT.....</b>	<b>29</b>
8.1 PROVISIONS APPLICABLE .....	29
8.2 MEASUREMENT PROCEDURE .....	29
8.3 MEASUREMENT INSTRUMENT.....	30
8.4 MEASUREMENT DATA .....	31
<b>9 CONDUCTED EMISSION MEASUREMENT.....</b>	<b>35</b>

9.1 STANDARD APPLICABLE..... 35

9.2 MEASUREMENT PROCEDURE ..... 35

9.3 CONDUCTED EMISSION DATA ..... 36

9.4 CONDUCTED MEASUREMENT EQUIPMENT..... 38

**APPENDIX 1 CONDUCTED RF OUTOUT POWER..... 39**

**APPENDIX 2 EMISSION BANDWIDTH..... 40**

**APPENDIX 3 CONDUCTED EMISSION AT ANTENNA TERMINAL ..... 41**

**APPENDIX 4 POWER LINE CONDUCTED EMISSION..... 42**

## **1. GENERAL INFORMATION**

### **1.1 Product Description**

- a) Type of EUT : CDPD
- b) Trade Name : Z-COM
- c) Model No. : Z-Card210
- d) FCC ID : M4Y-ZCARD210
- e) Working Frequency : 824.04 to 848.97 MHz
- f) Power Supply : DC 5V From Notebook PC

### **1.2 Characteristics of Device**

This device is a CDPD wireless modem (transceiver) with a PCMCIA interface to plug into a PCMCIA slot. It meets the CDPD wireless standards Ver. 1.0 and 1.1 and supports UDC/TCP communication protocol for accessing the Internet and CDPD network.

### **1.3 Test Methodology**

Both conducted and radiated testing were performed according to the procedures in chapter 13 of ANSI C63.4, and for other requirement of cellular system is in accordance with EIA/IS-19-B. Details please see each separate measurement item.

### **1.4 Test Facility**

The open area test site and conducted measurement facility used to collect the radiated data is located on the roof top of Building at No.34, 5 Lirn, Din Fu Tsun, Lin Kou, Taipei, Taiwan, R.O.C.

This site has been fully described in a report submitted to your office, and accepted in a letter dated Feb. 10 , 1997.

## 2. REQUIREMENTS OF PROVISIONS

### 2.1 Definition

Intentional radiator:

A device that intentionally generates and emits radio frequency energy by radiation or induction.

### 2.2 Frequencies Available

According to section § 22.902 of Part 22, the following frequencies are available for cellular system operations :

1) Cellular system A with 30 kHz channel spacing:

Mobile Frequencies (MHz)

824.040, 824.070.....	834.990
845.010, 845.040.....	846.480

2) Cellular system B with 30 kHz channel spacing:

Mobile Frequencies (MHz)

835.020, 835.050.....	844.980
846.510, 846.540.....	848.970

### 2.3 Requirements for Type Acceptance

The following requirements is according to FCC rules part 2 for type acceptance:

#### (1) RF Output Power

For transmitters other than SSB, ISB and controlled carrier radiotelephone, the power output shall be measured at the RF output terminals with electrical characteristics of the RF load attached.

#### (2) Modulation Characteristics

For Voice Modulated Communication Equipment, a curve or equivalent data showing the frequency response of the audio modulating circuit over a range of 100 to 5000 Hz shall be submitted.

For equipment which employs modulation limiting, a curve or family of curves showing the percentage of modulation versus the modulation input voltage should be supplied.

### **(3) Occupied Bandwidth**

The occupied bandwidth, that is the frequency bandwidth such that, below its lower and above its upper frequency limits, the mean powers radiated are each equal to 0.5 percent of the total mean power radiated by a given emission.

For radiotelephone transmitters equipped with a device to limit modulation or peak envelope power shall be modulated as follows :

Other than SSB or ISD transmitters when modulated by a 2500 Hz tone at an input level 16 dB greater than that necessary to produce 50 percent modulation. The input level shall be established at the frequency of maximum response of the audio modulating circuit.

### **(4) Spurious Emissions at Antenna Terminals**

The radio frequency voltage or power generated within the equipment and appearing on a spurious frequency shall be checked at the equipment output terminal when properly loaded with a suitable artificial antenna.

### **(5) Field Strength of Spurious Emissions**

Measurements shall be made to detect spurious emission that may be radiated directly from the cabinet, control circuits, power leads, or intermediate circuit elements under normal condition of installation and operation.

### **(6) Frequencies Tolerance**

- a) The frequency stability shall be measured with variation of ambient temperature.
- b) The frequency stability shall be measured with variation of primary supply voltage.

## **2.4 Labeling Requirement**

Each equipment for which a type acceptance application is filed on or after May 1,1981, shall bear an identification plate or label pursuant to § 2.925 ( Identification of equipment ) and § 2.926 ( FCC identifier ) .

## **2.5 User Information**

The users manual or instruction manual for an intentional or unintentional radiator shall caution the user that changes or modifications not expressly approved by the party responsible for compliance could void the user's authority to operate the equipment.

### 3. OUTPUT POWER MEASUREMENT

#### 3.1 Provision Applicable

According to § 22.913, for mobile stations the output power shall not exceed 7 Watts (E.R.P).

#### 3.2 Measurement Procedure

##### A. Conducted measured

1. Check the calibration of the measuring instrument using either an internal calibrator or a known signal from an external generator.
2. Position the EUT as shown in figure 1 without connection to measurement instrument. Turn on the EUT and connect its antenna terminal to measurement instrument via a low loss cable. Then set it to any one measured frequency within its operating range and make sure the instrument is operated in its linear range.
3. Set spectrum analyzer RBW to 1M kHz and VBW to 1 MHz., and adjust spectrum analyzer center frequency at the highest amplitude appearing on spectral display. Then set spectrum analyzer frequency span to 5M Hz.
4. Measure the highest amplitude appearing on spectral display and record the level as result data.
5. Repeat above procedures until all frequencies measured were complete.

Figure 1 : Output power measurement configuration

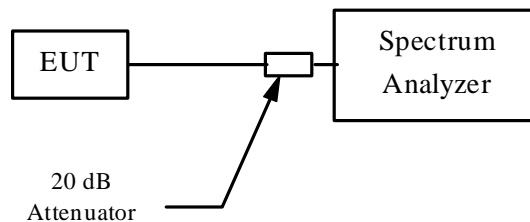

##### B. ERP

1. Setup the configuration per figure 3 and 4 for frequencies measured below and above 1 GHz respectively, adjusting the input voltage to produce the maximum power as measured in above conducted output power measurement.
2. Adjust the analyzer for each frequency measured in chapter 6 on a 1 MHz frequency span and 100 kHz resolution bandwidth.



3. The search antenna is to be raised and lowered over a range from 1 to 4 meters in horizontally polarized orientation. Position the highness when the highest value is indicated on spectrum analyzer, then change the orientation of EUT on test table over a range from 0° to 360° , and record the highest value indicated on spectrum analyzer as reference value.
4. Repeat step 3 until all frequencies need to be measured were complete.
5. Repeat step 4 with search antenna in vertical polarized orientations.
6. Replace the EUT with a tuned dipole antenna (horn antenna for above 1 GHz) relative to each frequency in horizontally polarized orientation and as the same polarized orientation with search antenna. Connect the tuned dipole antenna to a standard signal generator (SG) via a low loss cable. Power on the SG and tune the right frequency in measuring as well as set SG at a appreciated output level. Rise and lower the search antenna to get the highest value on spectrum analyzer, and then hold this position. Adjust the SG output to get a value as close as that derived from step 3 on spectrum analyzer. Record this value for result calculated.
7. Repeat step 6 until all frequencies need to be measured were complete.
8. Repeat step 7 with both dipole antenna (horn antenna for above 1 GHz) and search antenna in vertical polarized orientations.

Figure 3 : Frequencies measured below 1 GHz configuration

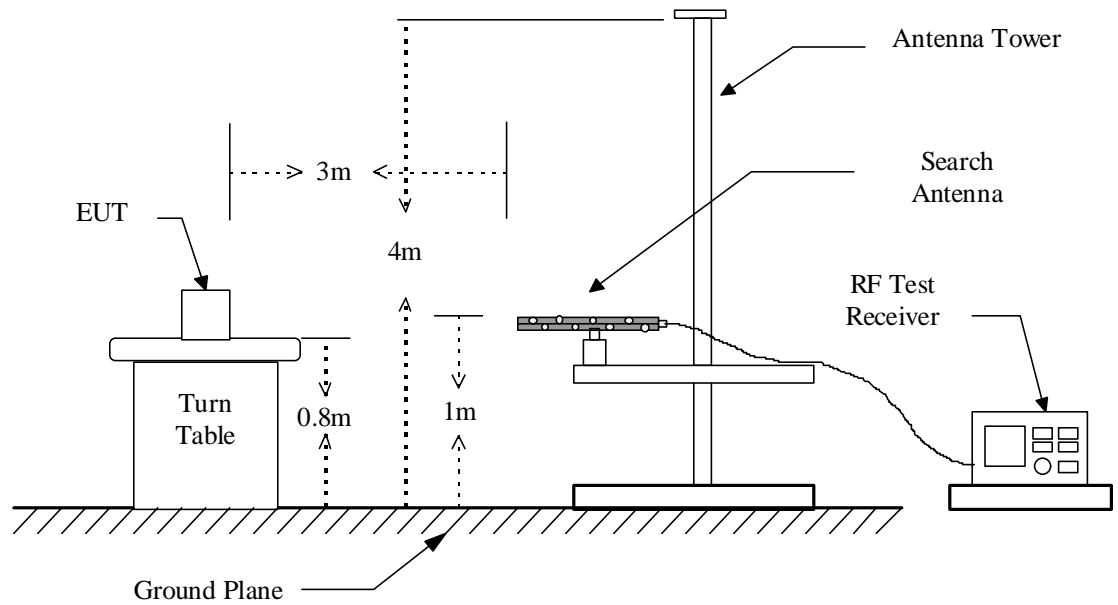
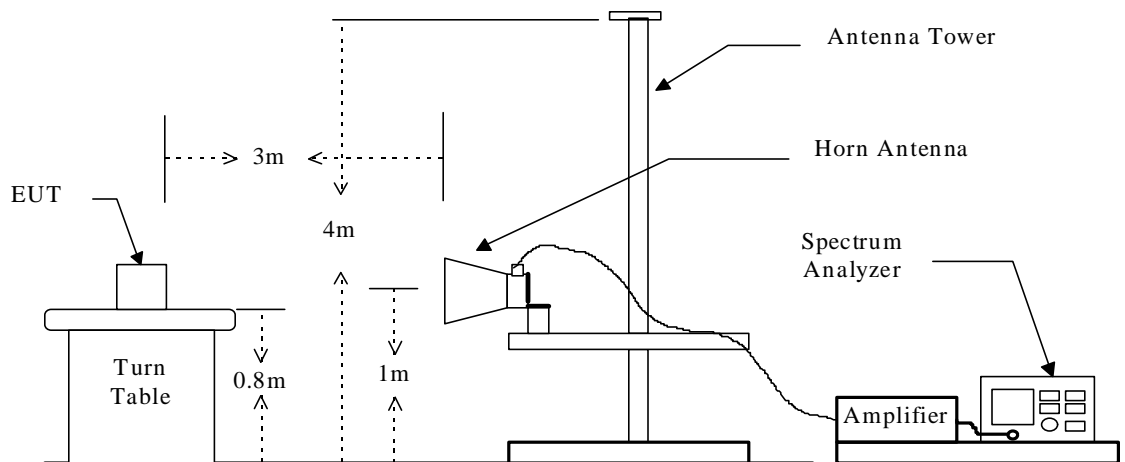

Figure 4 : Frequencies measured above 1 GHz configuration



### 3.3 Test Data

#### A. Conducted measured

Operated mode : Normal  
Temperature : 24

Test Date : DEC. 29, 1999  
Humidity : 70 %

Low Frequency: 824.04 MHz						
Power Level	SA Reading (dBm)	Cable Loss (dB)	Attenuator (dB)	Result (dBm)	Output Power ( W )	Limit ( W )
0	7.17	1.5	20	28.67	0.736	7
1	7.17	1.5	20	28.67	0.736	7
2	7.17	1.5	20	28.67	0.736	7
3	2.50	1.5	20	24.00	0.251	7
4	-1.50	1.5	20	20.00	0.100	7
5	-5.50	1.5	20	16.00	0.040	7
6	-9.50	1.5	20	12.00	0.016	7
7	-13.80	1.5	20	7.70	0.006	7
Middle Frequency: 836.01 MHz						
Power Level	SA Reading (dBm)	Cable Loss (dB)	Attenuator (dB)	Result (dBm)	Output Power ( W )	Limit ( W )
0	7.17	1.5	20	28.67	0.736	7
1	7.17	1.5	20	28.67	0.736	7
2	7.17	1.5	20	28.67	0.736	7
3	2.50	1.5	20	24.00	0.251	7
4	-1.83	1.5	20	19.67	0.093	7
5	-5.50	1.5	20	16.00	0.040	7
6	-9.67	1.5	20	11.83	0.215	7
7	-13.33	1.5	20	8.17	0.007	7
High Frequency: 848.97 MHz						
Power Level	SA Reading (dBm)	Cable Loss (dB)	Attenuator (dB)	Result (dBm)	Output Power ( W )	Limit ( W )
0	7.00	1.5	20	28.50	0.708	7
1	7.00	1.5	20	28.50	0.708	7
2	7.00	1.5	20	28.50	0.708	7
3	2.33	1.5	20	23.83	0.242	7
4	-1.50	1.5	20	20.00	0.100	7
5	-5.33	1.5	20	16.17	0.041	7
6	-9.50	1.5	20	12.00	0.016	7
7	-13.17	1.5	20	8.33	0.007	7

Note: Result = SA Reading + Cable Loss + Attenuator

**Pease see Appendix 1 for plotted graphs.**

**B. ERP**

Operated mode : Normal

Test Date : Oct. 26, 1999

Temperature : 22

Humidity : 70 %

SG @ 20 dBm

Frequency ( MHz )	SA Reading (dBuV)	SG Reading (dBuV)	Cable Loss (dB)	Result (dBm)	ERP ( W )	Limit ( W )
824.04	97.5	86.8	-2.4	28.3	0.676	7
836.01	97.3	86.8	-2.4	28.1	0.646	7
848.97	95.6	86.0	-2.4	27.2	0.525	7

**3.3 Result Calculation**

The conducted result is calculated as following equation :

a. For conducted output power measurement:

$$\text{Result} = \text{Reading} + \text{Cable Loss} + \text{Attenuation of Attenuator (if any)}$$

b. For ERP measurement:

$$\text{Result} = \text{SA Reading} - \text{SG Reading} + 20 + \text{Cable Loss}$$

$$\text{c. } W = \log^{-1} \left[ \frac{\text{Result(dBm)}}{10} \right] / 1000$$

**3.4 Output Power Test Equipment**

Equipment	Manufacturer	Model No.	Cal. Date
Spectrum Analyzer	Hewlett-Packard	8568B	JAN. 10, 2001
Pre-selector	Hewlett-Packard	85685A	JAN. 10, 2001
Quasi Peak Detector	Hewlett-Packard	85650A	JAN. 10, 2001
Log periodic Antenna	EMCO	3146	NOV. 03, 2000
Dipole Antenna	EMCO	3121C	SEP. 22, 2000

## 4. MODULATION CHARACTERISTICS

### 4.1 Provisions Applicable

According to § 2.987 (a), for Voice Modulated Communication Equipment, the frequency response of the audio modulating circuit over a range of 100 to 5000 Hz shall be measured. And in accordance with § 2.987 (b), for equipment which employs modulation limiting, a curve or family of curves showing the percentage of modulation versus the modulation input voltage should be supplied.

According to § 22.915 (b), the levels of the modulating signals must be set to the values specified as follows and must be maintained within  $\pm 10$  percent of those values :

- 1) The instantaneous frequency deviation resulting from main modulating signal must be  $\pm 12$ kHz.
- 2) The instantaneous frequency deviation resulting from SAT must be  $\pm 2$ kHz.
- 3) The instantaneous frequency deviation resulting from ST must be  $\pm 8$ kHz.
- 4) The instantaneous frequency deviation resulting from wideband data signals must be  $\pm 8$ kHz.

According to § 22.915 (c), cellular transmitters shall be equipped with circuitry that automatically prevents modulation levels for voice transmissions from exceeding the limits.

Per § 22.915 (d)(1), for audio filter characteristics of mobile stations, radiotelephony signals applied to the modulator from the modulation limiter must be attenuated, relative to the level at 1 kHz, as a function of frequency as follows :

- 1) In the frequency range of 3.0 kHz to 5.9 kHz and 6.1 to 15 kHz, signals must be attenuated at least  $40 \log(f/3)$  dB, where f is the frequency of the signal in kHz.
- 2) In the frequency range of 5.9 kHz to 6.1 kHz, signals must be attenuated at least 35 dB,
- 3) In the frequency above 15 kHz, signals must be attenuated at least 28 dB,

### 4.2 Measurement Method

#### A) Modulation Limit

1. Position the EUT as shown in figure 2, set the audio input frequency to 2.5 kHz and adjust the input level to produce  $\pm 8$  kHz deviation, and then record the level.
2. Adjust audio frequency from 100 Hz to 5000 Hz in sequence with a constant level of 20 dB greater than the level obtained in step 1. Record respective deviation as measuring result.
3. Set SAT active by computer program and record the deviation indicated on instrument.
4. Set ST active by computer program and record the deviation indicated on instrument.

5. Set wideband data active by computer program and record the deviation indicated on instrument.
6. Repeat above steps until measured channels complete.

#### B) Frequency response

1. Position the EUT as shown in figure 2, set the audio input frequency to 1000 Hz and adjust the input level greater than 20 dB to produce 50 % modulation in EUT, and note the output level on measuring instrument as a reference level.
2. Vary the modulating frequency from 300 Hz to 50000 Hz, and observe and record the change in output while maintaining a constant audio input level same as above step.

Figure 2 : Modulation characteristic measurement configuration

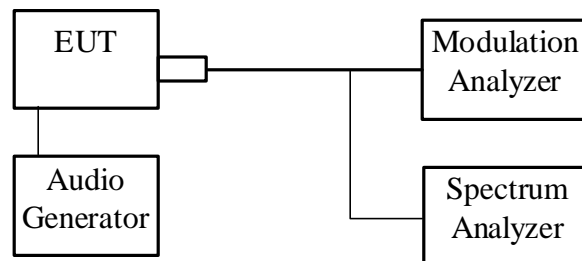

### 4.3 Measurement Instrument

Equipment	Manufacturer	Model No.	Next Cal. Date
Modulation Analyzer	Hewlett-Packard	8901A	NOV. 18, 2000
Multifunction Synthesizer	Hewlett-Packard	8904A	DEC. 01, 2000

#### **4.4 Measurement Result**

Not applicable, for this device is operated without any analog or audio signals input.

## 5. OCCUPIED BANDWIDTH OF EMISSION

### 5.1 Provisions Applicable

According to § 2.989 (e)(3), For radiotelephone transmitters equipped with a device to limit modulation or peak envelope power shall be modulated as follows :

Other than SSB or ISD transmitters when modulated by a 2500 Hz tone at an input level 16 dB greater than that necessary to produce 50 percent modulation. The input level shall be established at the frequency of maximum response of the audio modulating circuit.

Per § 22.9.5 (a)(1), all channels have a bandwidth of 40 kHz.

### 5.2 Measurement Method

1. Check the calibration of the measuring instrument using either an internal calibrator or a known signal from an external generator.
2. Position the EUT as shown in figure 2. Turn on the EUT and set it to any one convenient frequency within its operating range. Set a reference level on the measuring instrument equal to the highest peak value.
3. If the EUT is able to operate with analogue or audio, apply a 2.5 kHz modulation signal with a level of greater than 16 dB to produce 50 % modulation in EUT and measure the frequencies of the modulated signal from the EUT where it is 26 dB below the reference level set in step 2. This is the occupied bandwidth specified.
4. If the EUT is able to operate with AMPS system, apply a DTMF signal to EUT and also activate SAT, and then measure the frequencies of the modulated signal from the EUT where it is 26 dB below the reference level set in step 2. This is the occupied bandwidth specified.
5. If the EUT is able to operate with analogue or audio, apply a 1 kHz modulation signal with a level of greater than 20dB to produce  $\pm 8$  kHz deviation in EUT and measure the frequencies of the modulated signal from the EUT where it is 26 dB below the reference level set in step 2. This is the occupied bandwidth specified.
6. Operating with each internal signal to obtain possible maximum bandwidth of emission and measure the frequencies of the modulated signal from the EUT where it is 26 dB below the reference level set in step 2. This is the occupied bandwidth specified.



### 5.3 Occupied Bandwidth Test Equipment

Equipment	Manufacturer	Model No.	Next Cal. Date
Spectrum Analyzer	Adventest	R3261	SEP. 26, 2000
Modulation Analyzer	Hewlett-Packard	8901A	NOV. 18, 2000
Multifunction Synthesizer	Hewlett-Packard	8904A	DEC. 01, 2000
Plotter	Hewlett-Packard	7440A	N/A

### 5.4 Bandwidth Measurement

For this device is a CDPD-based product and there is no analogue or audio operation, therefore the emission bandwidth measured is under the condition of modulation with internal signals, such as maximum transmission data rate with Pseudo random data.

#### A. Low Frequency : 824.04 MHz

##### A.1 Reference Carrier Level

##### A.2 Pseudo random data at 19.2 kbps, span 100 kHz

##### A.3 Pseudo random data at 19.2 kbps, span 300 kHz

##### A.4 Pseudo random data versus 9.6 kHz digital signal, span 100 kHz

##### A.5 Pseudo random data versus 9.6 kHz digital signal, span 300 kHz

#### B. Middle Frequency : 836.49 MHz

##### B.1 Reference Carrier Level

##### B.2 Pseudo random data at 19.2 kbps, span 100 kHz

##### B.3 Pseudo random data at 19.2 kbps, span 300 kHz

##### B.4 Pseudo random data versus 9.6 kHz digital signal, span 100 kHz

##### B.5 Pseudo random data versus 9.6 kHz digital signal, span 300 kHz

#### C. High Frequency : 848.97 MHz

##### C.1 Reference Carrier Level

##### C.2 Pseudo random data at 19.2 kbps, span 100 kHz

##### C.3 Pseudo random data at 19.2 kbps, span 300 kHz

##### C.4 Pseudo random data versus 9.6 kHz digital signal, span 100 kHz

##### C.5 Pseudo random data versus 9.6 kHz digital signal, span 300 kHz

**Pease see Appendix 2 for plotted graphs.**

## 6. SPURIOUS EMISSIONS AT ANTENNA TERMINALS

### 6.1 Provisions Applicable

According to § 2.991, the radio frequency voltage or power generated within the equipment and appearing on a spurious frequency shall be checked at the equipment output terminal when properly loaded with a suitable artificial antenna.

According to § 22.917 (b),

- 1) for F3E and F3D emissions the mean power of emissions must be attenuated below the mean power of the unmodulated carrier as follows :
  - i) On any frequency removed from the carrier frequency by greater than 20 kHz up to and including 45 kHz : at least 26 dB.
  - ii) On any frequency removed from the carrier frequency by greater than 45 kHz up to the first multiple of the carrier frequency : at least  $43 + 10\log(\text{mean output power in Watts})$  dB or 60 dB, whichever is the lesser attenuation.
  
- 2) For F1D emissions, the mean power of emissions must be attenuated below the mean power of the unmodulated carrier as follows :
  - i) On any frequency removed from the carrier frequency by greater than 20 kHz up to and including 45 kHz : at least 26 dB.
  - ii) On any frequency removed from the carrier frequency by more than 45 kHz up to and including 90 kHz : at least 45 dB.
  - iii) On any frequency removed from the carrier frequency by more than 90 kHz up to the first multiple of the carrier frequency : at least  $43 + 10\log(\text{mean output power in Watts})$  dB or 60 dB, whichever is the lesser attenuation.
  
- 3) The mean power of emissions must be attenuated below the mean power of the unmodulated carrier on any frequency twice or greater than twice the fundamental frequency by at least  $43 + 10\log(\text{mean output power in Watts})$  dB.
  
- 4) The mean power of any emissions appearing in the base station frequency range from mobile transmitters operated in this service shall be attenuated to a level not to exceed  $-80$  dBm at the transmit antenna connector.

## 6.2 Measurement Procedure

1. Check the calibration of the measuring instrument using either an internal calibrator or a known signal from an external generator.
2. Position the EUT as shown in figure 1 without connection to measurement instrument. Turn on the EUT and connect its antenna terminal to measurement instrument via a low loss cable. Then set it to any one measured frequency within its operating range and make sure the instrument is operated in its linear range.
3. Set resolution bandwidth of spectrum analyzer as follows :
  - 1) When operating in the radiotelephony mode or the SAT mode :
    - a) for any emission not more than 45 kHz removed from the carrier : 300Hz ;
    - b) for any emission more than 45 kHz removed from the carrier : 30 kHz.
  - 2) When operating in the wideband data mode or the ST mode :
    - a) for any emission not more than 45 kHz removed from the carrier : 300Hz ;
    - b) for any emission more than 45 kHz removed from the carrier : 30 kHz.
4. Measure the emissions of all frequency band specified in applicable rules and record the measurement data.
5. Repeat above procedures until all measured frequencies were complete.

## 6.3 Measurement Equipment

Equipment	Manufacturer	Model No.	Next Cal. Date
Spectrum Analyzer	Hewlett-Packard	8563A	JUL. 02, 2000
Attenuator	Weinschel Engineering	1	JUL. 02, 2000
High Pass Filter	HP	N/A	JUL. 02, 2000
Preapmlifier	HP	8449B	JUN. 21, 2000

## 6.4 Measurement Data

a) Low frequency: 824.04 MHz

Operated mode : Normal  
Temperature : 22

Test Date : Oct. 26, 1999  
Humidity : 70 %

Unmodulated carrier power is 28.7 dBm , or 736 mW (Conducted).

The limit of spurious or harmonics is  $28.7 - [43 + 10 \log(\text{output power in W})]$ , or -13dBm

Frequency ( MHz)	SA Reading (dBm )	Corrected Factor (dB)	Amplifier Gain (dB)	Result ( dBm )	Limit (dBm)	Margin ( dB )
869.038	--	2.9	-25.0	--	-80.0	--
1648.000	-29.3	3.2	-37.0	-63.1	-13.0	-50.1
2472.000	-42.1	3.3	-36.3	-75.1	-13.0	-62.1
3296.000	-44.0	3.4	-36.1	-76.7	-13.0	-63.7
4120.000	-44.3	3.6	-35.4	-76.1	-13.0	-63.1
4944.200	-35.7	3.6	-35.7	-67.8	-13.0	-54.8
5768.200	-38.0	3.7	-35.6	-69.9	-13.0	-56.9
6592.300	-37.8	3.8	-35.7	-69.7	-13.0	-56.7
7416.300	-43.5	3.9	-35.9	-75.5	-13.0	-62.5
8240.400	-44.7	3.9	-36.3	-77.1	-13.0	-64.1
9064.448	-42.6	4.1	-36.6	-75.1	-13.0	-62.1
10712.450	--	4.1	--	--	-13.0	--

Note:

1. Remark “ -- “ means that the emission level is too weak to be measured.
2. No emission frequency from EUT appears in base frequency range, when measured frequency of Rx local oscillator with a amplifier of 25 dB gain.
3. Result = SA Reading + Corrected Factor + Amplifier Gain

**Pease see Appendix 3 for plotted graphs.**

b) Middle frequency: 836.01 MHz

Operated mode : Normal  
Temperature : 22

Test Date : Oct. 26, 1999  
Humidity : 70 %

Unmodulated carrier power is 28.7 dBm , or 736 mW (Conducted).

The limit of spurious or harmonics is  $28.7 - [43 + 10 \log(\text{output power in W})]$ , or -13dBm

Frequency ( MHz)	SA Reading (dBm )	Corrected Factor (dB)	Amplifier Gain (dB)	Result ( dBm )	Limit (dBm)	Margin ( dB )
881.489	--	2.9	-25.0	--	-80.0	--
1672.017	-16.7	3.2	-37.0	-50.5	-13.0	-37.5
2508.031	-41.0	3.3	-36.3	-74.0	-13.0	-61.0
3344.041	-42.3	3.4	-36.1	-75.0	-13.0	-62.0
4180.049	-39.8	3.6	-35.4	-71.6	-13.0	-58.6
5016.058	-37.3	3.6	-35.7	-69.4	-13.0	-56.4
5852.071	-40.4	3.7	-35.6	-72.3	-13.0	-59.3
6688.078	-39.6	3.8	-35.7	-71.5	-13.0	-58.5
7524.092	-42.5	3.9	-35.9	-74.5	-13.0	-61.5
8360.103	-44.2	3.9	-36.3	-76.6	-13.0	-63.6
9196.108	-43.0	4.1	-36.6	-75.5	-13.0	-62.5
10032.117	--	4.1	--	--	-13.0	--

Note:

1. Remark “ -- “ means that the emission level is too weak to be measured.
2. No emission frequency from EUT appears in base frequency range, when measured frequency of Rx local oscillator with a amplifier of 25 dB gain.
3. Result = SA Reading + Corrected Factor + Amplifier Gain

**Pease see Appendix 3 for plotted graphs.**

c) High frequency: 848.97 MHz

Operated mode : Normal  
Temperature : 22

Test Date : Oct. 26 , 1997  
Humidity : 70 %

Unmodulated carrier power is 28.5 dBm , or 708 mW (Conducted).

The limit of spurious or harmonics is  $28.5 - [43 + 10 \log(\text{output power in W})]$ , or -13dBm

Frequency ( MHz)	SA Reading (dBm )	Corrected Factor (dB)	Amplifier Gain (dB)	Result ( dBm )	Limit (dBm)	Margin ( dB )
893.967	--	2.9	-25.0	--	-80.0	--
1697.940	-21.5	3.2	-37.0	-55.3	-13.0	-42.3
2546.908	-41.5	3.3	-36.3	-74.5	-13.0	-61.5
3395.878	-43.1	3.4	-36.1	-75.8	-13.0	-62.8
4244.843	-43.0	3.6	-35.4	-74.8	-13.0	-61.8
5093.816	-38.3	3.6	-35.7	-70.4	-13.0	-57.4
5942.785	-39.2	3.7	-35.6	-71.1	-13.0	-58.1
6791.753	-37.3	3.8	-35.7	-69.2	-13.0	-56.2
7640.723	-39.3	3.9	-35.9	-71.3	-13.0	-58.3
8489.692	-40.5	3.9	-36.3	-72.9	-13.0	-59.9
9338.660	-43.7	4.1	-36.6	-76.2	-13.0	-63.2
10187.630	--	4.1	--	--	-13.0	--

Note:

1. Remark “ -- “ means that the emission level is too weak to be measured.
2. No emission frequency from EUT appears in base frequency range, when measured frequency of Rx local oscillator with a amplifier of 25 dB gain.
3. Result = SA Reading + Corrected Factor + Amplifier Gain

**Pease see Appendix 3 for plotted graphs.**

## 7. FIELD STRENGTH OF EMISSION

### 7.1 Provisions Applicable

According to § 2.993 (b)(3), Measurements shall be made to detect spurious emission that may be radiated directly from the cabinet, control circuits, power leads, or intermediate circuit elements under normal condition of installation and operation. Information submitted shall include the relative radiated power of spurious emission with reference to the rated power output of the transmitter, assuming all emissions are radiated from a halfwave dipole antenna.

According to § 22.917 (e), all out of band emissions shall be attenuated below the unmodulated carrier by at least 43 plus 10 Log(output power in watts) dB and per § 22.917 (f) mobile emissions in base frequency range, the mean power of any emissions appearing in the base station frequency range from mobile transmitters operated in this service shall be attenuated to a level not to exceed -80 dBm at the transmit antenna connector.

Per 15.109(a), except for Class A digital device, the field strength of radiated emissions at a distance of 3 meters shall not exceed the following:

Frequency MHz	Distance Meters	Radiated dB $\mu$ V/m	Radiated $\mu$ V/m
30 - 88	3	40.0	100
88 - 216	3	43.5	150
216 - 960	3	46.0	200
above 960	3	54.0	500

### 7.2 Measurement Procedure

#### A. ERP Measurement

1. Please refer to procedure of section 3.2 B. output power measurement (ERP).

## **B. Radiated Emission**

1. Setup the configuration per figure 3 and 4 for frequencies measured below and above 1 GHz respectively.
2. For emission frequencies measured below 1 GHz, a pre-scan is performed in a shielded chamber to determine the accurate frequencies of higher emissions will be checked on a open test site. As the same purpose, for emission frequencies measured above 1 GHz, a pre-scan also be performed with a 1 meter measuring distance before final test.
3. For emission frequencies measured below and above 1 GHz, set the spectrum analyzer on a 100 kHz and 1 MHz resolution bandwidth respectively for each frequency measured in step 2.
4. The search antenna is to be raised and lowered over a range from 1 to 4 meters in horizontally polarized orientation. Position the highness when the highest value is indicated on spectrum analyzer, then change the orientation of EUT on test table over a range from 0° to 360° with a speed as slow as possible, and keep the azimuth that highest emission is indicated on the spectrum analyzer. Vary the antenna position again and record the highest value as a final reading. A RF test receiver is also used to confirm emissions measured.
5. Repeat step 4 until all frequencies need to be measured were complete.
6. Repeat step 5 with search antenna in vertical polarized orientations.
7. Check the three frequencies of highest emission with varying the placement of cables associated with EUT to obtain the worse case and record the result.



### 7.3 Measuring Instrument

Equipment	Manufacturer	Model No.	Next Cal. Date
Spectrum Analyzer	Hewlett-Packard	8568B	JAN. 10, 2001
Pre-selector	Hewlett-Packard	85685A	JAN. 10, 2001
Quasi Peak Detector	Hewlett-Packard	85650A	JAN. 10, 2001
Spectrum Analyzer	Hewlett-Packard	8564E	JUL. 02, 2000
Horn Antenna	EMCO	3115	MAY 12, 2000
Log periodic Antenna	EMCO	3146	SEP. 17, 2000
Biconical Antenna	EMCO	3110	SEP. 22, 2000
Dipole Antenna	EMCO	3121C	MAY 24, 2000
Preamplifier	Hewlett-Packard	8449B	JUN. 21, 2000
Preamplifier	Hewlett-Packard	8447D	SEP. 19, 2000

Measuring instrument setup in frequency band measured is as following :

Frequency Band (MHz)	Instrument	Function	Resolution bandwidth	Video Bandwidth
30 to 1000	Spectrum Analyzer	Peak	100 kHz	100 kHz
Above 1000	Spectrum Analyzer	Peak	1 MHz	1 MHz

## 7.4 Measuring Data

a) Low frequency: 824.04 MHz

Operated mode : Normal  
Temperature : 22

Test Date : Oct. 26, 1999  
Humidity : 70 %

Unmodulated carrier output power is 28.3 dBm , or 676 mW (ERP).

The limit of spurious or harmonics is calculated as following :

$$28.3-[43+10\log(\text{carrier output power in W})], \text{ or } -13\text{dBm}$$

Frequency (MHz)	Meter Reading (dBm)	SG Reading (dBm)	Cable Loss (dB)	Antenna Gain Corrected	Result (dBm)	Limit (dBm)	Margin (dB)
869.038	--	--	-7.5	0.0	--	-80.0	--
1648.080	-19.7	-30.2	-1.3	7.8	-23.7	-13.0	-10.7
2472.145	-41.5	-50.9	-1.7	7.3	-45.3	-13.0	-32.3
3296.185	-44.8	-48.5	-1.7	8.0	-42.2	-13.0	-29.2
4120.200	-47.2	-50.6	-2.1	8.9	-43.8	-13.0	-30.8
4944.265	-40.5	-43.0	-2.1	8.9	-36.2	-13.0	-23.2
5768.280	-46.7	-48.8	-2.5	9.3	-42.0	-13.0	-29.0
6592.320	-50.7	-51.1	-2.5	9.8	-43.8	-13.0	-30.8
7416.447	--	--	--	--	--	-13.0	--
8240.500	--	--	--	--	--	-13.0	--
9064.548	--	--	--	--	--	-13.0	--
10712.650	--	--	--	--	--	-13.0	--

Note :

1. Remark "--" means that the emission level is too weak to be detected.
2. Result calculation is as following :  
Result = SG Reading + Cable Loss + Antenna Gain Corrected  
Antenna Gain Corrected : is used for antenna other than dipole to convert radiated power to ERP.
3. Spurious or harmonics above 1 GHz is too low to be detected or attenuated more than 60 dB from limit value.
4. No emission frequency from EUT appears in base frequency range, when measured frequency of Rx local oscillator with a amplifier of 25 dB gain.

b) Middle frequency: 836.01 MHz

Operated mode : Normal

Test Date : Oct. 26, 1999

Temperature : 22

Humidity : 70 %

Unmodulated carrier output power is 28.1 dBm , or 646 mW (ERP).

The limit of spurious or harmonics is calculated as following :

$$28.1-[43+10\log(\text{carrier output power in W})], \text{ or } -13\text{dBm}$$

Frequency (MHz)	Meter Reading (dBm)	SG Reading (dBm)	Cable Loss (dB)	Antenna Gain Corrected	Result (dBm)	Limit (dBm)	Margin (dB)
881.488	--	--	-7.7	0.0	--	-80.0	--
1672.020	-14.1	-24.6	-1.3	7.8	-18.1	-13.0	-5.1
2508.030	-43.3	-52.8	-1.7	7.3	-47.2	-13.0	-34.2
3344.082	-48.8	-52.5	-1.7	8.0	-46.2	-13.0	-33.2
4180.092	-43.8	-47.3	-2.1	8.9	-40.5	-13.0	-27.5
5016.102	-41.2	-43.6	-2.1	8.9	-36.8	-13.0	-23.8
5852.078	-45.3	-47.5	-2.5	9.3	-40.7	-13.0	-27.7
6688.088	-48.0	-49.6	-2.5	9.8	-42.3	-13.0	-29.3
7524.090	--	--	--	--	--	-13.0	--
8360.100	--	--	--	--	--	-13.0	--
9196.110	--	--	--	--	--	-13.0	--
10032.120	--	--	--	--	--	-13.0	--

Note :

1. Remark "--" means that the emission level is too weak to be detected.
2. Result calculation is as following :  

$$\text{Result} = \text{SG Reading} + \text{Cable Loss} + \text{Antenna Gain Corrected}$$
 Antenna Gain Corrected : is used for antenna other than dipole to convert radiated power to ERP.
3. Spurious or harmonics above 1 GHz is too low to be detected or attenuated more than 60 dB from limit value.
4. No emission frequency from EUT appears in base frequency range, when measured frequency of Rx local oscillator with a amplifier of 25 dB gain.

c) High frequency: 848.97 MHz

Operated mode : Normal

Test Date : Oct. 26, 1999

Temperature : 22

Humidity : 70 %

Unmodulated carrier output power is 27.2 dBm , or 525 mW (ERP).

The limit of spurious or harmonics is calculated as following :

$$27.2 - [43 + 10 \log(\text{carrier output power in W})], \text{ or } -13 \text{ dBm}$$

Frequency (MHz)	Meter Reading (dBm)	SG Reading (dBm)	Cable Loss (dB)	Antenna Gain Corrected	Result (dBm)	Limit (dBm)	Margin (dB)
893.967	--	--	-7.9	0.0	--	-80.0	--
1697.982	-21.5	-32.0	-1.3	7.8	-25.5	-13.0	-12.5
2546.927	-42.5	-51.9	-1.7	7.3	-46.3	-13.0	-33.3
3395.873	-46.0	-49.6	-1.7	8.0	-43.3	-13.0	-30.3
4244.810	-48.0	-51.5	-2.1	8.9	-44.7	-13.0	-31.7
5093.738	-39.8	-42.3	-2.1	8.9	-35.5	-13.0	-22.5
5942.750	-47.0	-49.1	-2.5	9.3	-42.3	-13.0	-29.3
6791.696	-49.7	-51.3	-2.5	9.8	-44.0	-13.0	-31.0
7640.721	--	--	--	--	--	-13.0	--
8489.690	--	--	--	--	--	-13.0	--
9338.659	--	--	--	--	--	-13.0	--
10187.628	--	--	--	--	--	-13.0	--

Note :

1. Remark "--" means that the emission level is too weak to be detected.
2. Result calculation is as following :  

$$\text{Result} = \text{SG Reading} + \text{Cable Loss} + \text{Antenna Gain Corrected}$$
 Antenna Gain Corrected : is used for antenna other than dipole to convert radiated power to ERP.
3. Spurious or harmonics above 1 GHz is too low to be detected or attenuated more than 60 dB from limit value.
4. No emission frequency from EUT appears in base frequency range, when measured frequency of Rx local oscillator with a amplifier of 25 dB gain.

***Please see Exhibit F for Radiated Emission measurement Photos.***

## d) Other Emission

Operation Mode : TXTest Date : OCT. 12, 1999      Temperature : 26      Humidity: 65 %

Frequency (MHz)	Ant-Pol H/V	Meter Reading (dBuV)	Corrected Factor (dB)	Result @3m (dBuV/m)	Limit @3m (dBuV/m)	Margin (dB)	Table Degree (Deg.)	Ant. High (m)
80.064	V	46.6	-15.0	31.6	40.0	-8.4	180	1.00
192.021	H	44.5	-8.1	36.4	43.5	-7.1	180	2.00
200.486	H	48.7	-7.1	41.6	43.5	-1.9	180	2.00
233.900	H	42.1	-4.9	37.2	46.0	-8.8	90	2.00
267.314	H	45.5	-3.7	41.8	46.0	-4.2	90	1.80
280.214	H	43.1	-2.7	40.4	46.0	-5.6	180	1.80
334.164	H	51.1	-8.1	43.0	46.0	-3.0	180	2.10
360.269	H	48.0	-8.6	39.4	46.0	-6.6	180	1.90
964.213	H	44.9	3.3	48.2	54.0	-5.8	90	2.00

## e) Other Emission

Operation Mode : ChargerTest Date : DEC. 29, 1999      Temperature : 22      Humidity: 65 %

Frequency (MHz)	Ant-Pol H/V	Meter Reading (dBuV)	Corrected Factor (dB)	Result @3m (dBuV/m)	Limit @3m (dBuV/m)	Margin (dB)	Table Degree (Deg.)	Ant. High (m)
35.414	V	33.9	-10.9	23.0	40.0	-17.0	180	1.00
44.460	V	36.0	-12.8	23.2	40.0	-16.8	180	1.10
116.370	V	43.5	-11.1	32.4	43.5	-11.1	90	1.00
146.511	V	38.1	-10.3	27.8	43.5	-15.7	90	1.00
174.002	V	33.8	-9.0	24.8	43.5	-18.7	180	1.00
203.630	V	33.5	-6.9	26.6	43.5	-16.9	90	1.20

## 7.5 Details of Tested System

The radiated emissions test was performed in connection of the following devices:

<b>Device</b>	<b>Manufacture</b>	<b>Model / FCC ID.</b>	<b>Description</b>
CDPD	Z-Com, Inc.	Z-Card210 M4Y-ZCARD	----
Note Book	TATUNG CO.	TNB5900 BJMTNB5900	Power Adapter Cable 1.8m + 1.5m
Printer	HP	2225C+ DSI6XU2225	1.2m shielded Cable Adapter cord 1.9m
Modem	Smar TEAM Co.	1200AT EF56A51200AT	2.0m Shielded Cable

## **7.6 Radiation Setup Photos**

(Mode : TX)

Please see setup photos in Exhibit-F.

(Mode : CHARGER)

Please see setup photos in Exhibit-F



## 8. FREQUENCY STABILITY MEASUREMENT

### 8.1 Provisions Applicable

According to § 2.995 (a)(1), the frequency stability shall be measured with variation of ambient temperature from -30 to +50 centigrade, and according to § 2.995 (d), the frequency stability shall be measured with varying primary supply voltage from 85 to 115 percent of the nominal value for other than hand carried battery equipment. And per § 2.995 (d)(2), the frequency stability shall be measured with reducing primary supply voltage to the battery operating end point which is specified by the manufacturer.

According to § 22.355, the frequency stability of Cellular shall maintained within 0.00025 percent of the assigned frequency.

### 8.2 Measurement Procedure

A) Frequency stability versus environmental temperature and primary input AC voltage

1. Setup the configuration per figure 5 for frequencies measured at ambient temperature if it is within 15 to 25 . Otherwise, an environmental chamber set for a temperature of 20 shall be used. Install new batteries in the EUT.
2. Turn on EUT and set SA center frequency to the right frequency needs to be measured. Then set SA RBW to 30 kHz, VBW to 100kHz and frequency span to 500 kHz. Record this frequency to be a reference.
3. Set the temperature of chamber to 50 . Allow sufficient time (approximately 30 min) for the temperature of the chamber to stabilize. While maintaining a constant temperature inside the chamber, turn the EUT on and measure the EUT operating frequency at 2, 5 and 10 minutes after startup with varying input voltage to 85% and 115% of nominal input voltage.
4. Repeat step 2 with a 10 decreased per stage until the lowest temperature -30 is measured, record all measurement frequencies.

## B) Frequency stability versus input voltage

1. Setup the configuration per figure 5 for frequencies measured at ambient temperature if it is within 15 to 25 . Otherwise, an environmental chamber set for a temperature of 20 shall be used. Install new batteries in the EUT.
2. Set SA center frequency to the right frequency needs to be measured. Then set SA RBW to 30 kHz, VBW to 100kHz and frequency span to 500 kHz. Record this frequency to be a reference.
3. For battery operated only device, supply the EUT primary voltage at the battery operating end point which is specified by the manufacturer and record the frequency.

Figure 5 : Frequency stability measurement configuration

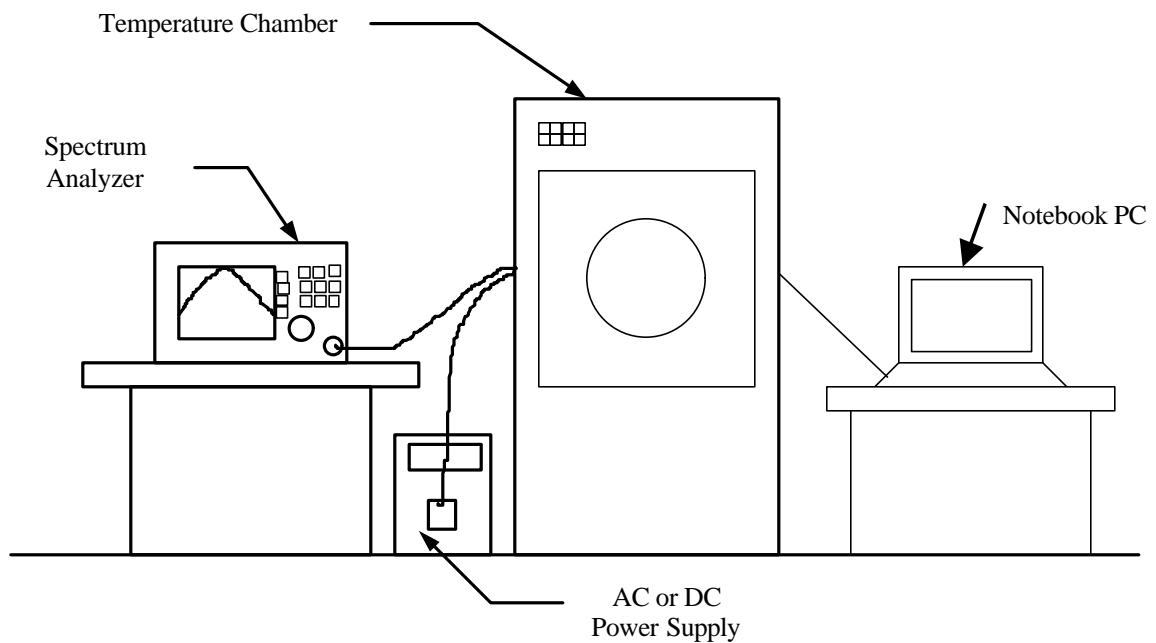

### 8.3 Measurement Instrument

Equipment	Manufacturer	Model No.	Next Cal. Date
Spectrum Analyzer	Adventest	R3361C	DEC. 17, 2000
Temperature Chamber	ACS	EOS 200T	DEC. 17, 2000

**8.4 Measurement Data**

Operated mode : Normal

Test Date : DEC. 29, 1999

A) Frequency stability versus environmental temperature and primary input level

Reference Frequency: 824.0401 (MHz)		Limit: 0.00025 (%)					
Environment Tempure ( )	Power Supplied (Vdc)	Frequency deviation measured with time elapse					
		2 minute		5 minute		10 minute	
		(MHz)	(%)	(MHz)	(%)	(MHz)	(%)
50	5.00	824.0397	-0.00005	824.0399	-0.00002	824.0405	0.00005
40	5.00	824.0397	-0.00005	824.0403	0.00002	824.0398	-0.00004
30	5.00	824.0406	0.00006	824.0414	0.00016	824.0399	-0.00002
20	5.00	824.0403	0.00002	824.0407	0.00007	824.0400	-0.00001
10	5.00	824.0410	0.00011	824.0412	0.00013	824.0402	0.00001
0	5.00	824.0406	0.00006	824.0400	-0.00001	824.0402	0.00001
-10	5.00	824.0402	0.00001	824.0388	-0.00016	824.0402	0.00001
-20	5.00	824.0412	0.00013	824.0415	0.00017	824.0413	0.00015
-30	5.00	824.0405	0.00005	824.0402	0.00001	824.0399	-0.00002

Reference Frequency: 836.0102 (MHz)		Limit: 0.00025 (%)					
Environment Temperture ( )	Power Supplied (Vdc)	Frequency deviation measured with time elapse					
		2 minute		5 minute		10 minute	
		(MHz)	(%)	(MHz)	(%)	(MHz)	(%)
50	5.00	836.0100	-0.00002	836.0104	0.00002	836.0117	0.00018
40	5.00	836.0094	-0.00010	836.0111	0.00011	836.0087	-0.00018
30	5.00	836.0105	0.00004	836.0104	0.00002	836.0108	0.00007
20	5.00	836.0092	-0.00012	836.0101	-0.00001	836.0104	0.00002
10	5.00	836.0101	-0.00001	836.0107	0.00006	836.0108	0.00007
0	5.00	836.0099	-0.00004	836.0108	0.00007	836.0112	0.00012
-10	5.00	836.0105	0.00004	836.0102	0.00000	836.0091	-0.00013
-20	5.00	836.0112	0.00012	836.0110	0.00010	836.0118	0.00019
-30	5.00	836.0095	-0.00008	836.0109	0.00008	836.0101	-0.00001

Reference Frequency: 848.9701(MHz)		Limit: 0.00025 (%)					
Environment Temperture ( )	Power Supplied (Vdc)	Frequency deviation measured with time elapse					
		2 minute		5 minute		10 minute	
		(MHz)	(%)	(MHz)	(%)	(MHz)	(%)
50	5.00	848.9695	-0.00007	848.9704	0.00004	848.9691	-0.00012
40	5.00	848.9698	-0.00004	848.9696	-0.00006	848.9712	0.00013
30	5.00	848.9689	-0.00014	848.9701	0.00000	848.9700	-0.00001
20	5.00	848.9692	-0.00011	848.9706	0.00006	848.9705	0.00005
10	5.00	848.9706	0.00006	848.9699	-0.00002	848.9703	0.00002
0	5.00	848.9688	-0.00015	848.9705	0.00005	848.9692	-0.00011
-10	5.00	848.9690	-0.00013	848.9690	-0.00013	848.9717	0.00019
-20	5.00	848.9711	0.00012	848.9692	-0.00011	848.9692	-0.00011
-30	5.00	848.9697	-0.00005	848.9699	-0.00002	848.9700	-0.00001

## B) Frequency stability versus end point supply voltage ( 3.3 Vdc)

Limit: 0.00025 (%)							
Reference Frequency (MHz)	Power Supplied (Vdc)	Frequency deviation measured with time elapse					
		2 minute		5 minute		10 minute	
		(MHz)	(%)	(MHz)	(%)	(MHz)	(%)
824.0401	3.3	824.0406	0.00006	824.0405	0.00005	824.0398	-0.00004
836.0102	3.3	836.0113	0.00013	836.0091	-0.00013	836.0109	0.00008
848.9701	3.3	848.9693	-0.00009	848.9711	0.00012	848.9700	-0.00001

## 9 CONDUCTED EMISSION MEASUREMENT

### 9.1 Standard Applicable

For unintentional and intentional device, Line Conducted Emission Limits are in accordance to § 15.107(a) and § 15.207(a) respectively. Both Limits are identical specification.

### 9.2 Measurement Procedure

1. Setup the configuration per figure 3.
2. A preliminary scan with a spectrum monitor is performed to identify the frequency of emission that has the highest amplitude relative to the limit by operating the EUT in selected modes of operation, typical cable positions, and with a typical system configuration.
3. Record the 6 or 8 highest emissions relative to the limit.
4. Measure each frequency obtained from step 3 by a test receiver set on quasi peak detector function, and then record the accuracy frequency and emission level. If all emissions measured in the specified band are attenuated more than 20 dB from the limit, this step would be ignored, and the peak detector function would be used.
5. Confirm the highest three emissions with variation of the EUT cable configuration and record the final data.
6. Repeat all above procedures on measuring each operation mode of EUT.

Figure 3 : Conducted emissions measurement configuration

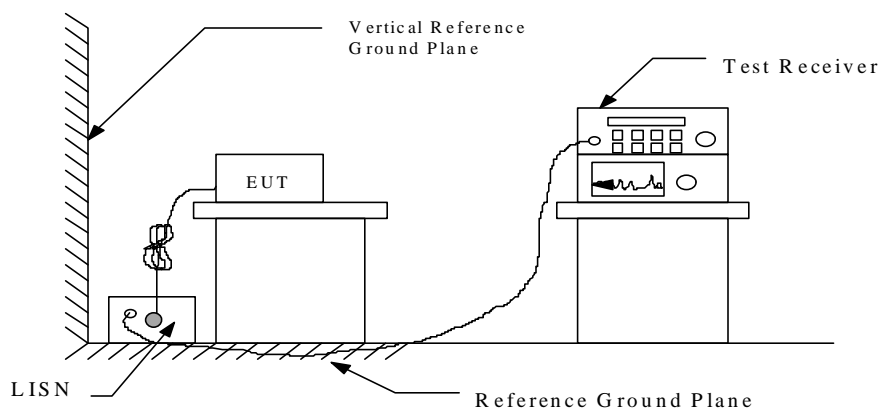

### 9.3 Conducted Emission Data

a) Low frequency : 824.04 MHz

Operation Mode : Transmitting

Test Date : OCT. 07, 1999

Temperature : 25

Humidity: 60 %

Frequency (MHz)	Reading (dBuV)		Factor (dB)	Result (dBuV)		Limit (dBuV)	Margin (dB)
	Va	Vb		Va	Vb		
0.4740	32.7	28.6	0.2	32.9	28.8	48.0	-15.1
0.5503	35.9	34.8	0.2	36.1	35.0	48.0	-11.9
0.9433	27.4	22.7	0.3	27.7	23.0	48.0	-20.3
3.4628	25.9	26.0	0.3	26.2	26.3	48.0	-21.7
12.8338	23.6	23.0	0.7	24.3	23.7	48.0	-23.7
21.6511	29.4	21.6	0.9	30.3	22.5	48.0	-17.7

**Note: Result = Reading + Factor**

**Pease see Appendix 4 for plotted graphs.**

b) Middle frequency : 836.01 MHz

Operation Mode : Transmitting

Test Date : OCT. 07, 1999

Temperature : 25

Humidity: 60 %

Frequency (MHz)	Reading (dBuV)		Factor (dB)	Result (dBuV)		Limit (dBuV)	Margin (dB)
	Va	Vb		Va	Vb		
0.4714	30.1	29.4	0.2	30.3	29.6	48.0	-17.7
0.5487	41.4	34.6	0.2	41.6	34.8	48.0	-6.4
0.9446	27.1	21.8	0.3	27.4	22.1	48.0	-20.6
3.4608	27.3	26.9	0.3	27.6	27.2	48.0	-20.4
13.8589	27.2	27.0	0.7	27.9	27.7	48.0	-20.1
22.6069	30.0	23.2	1.0	31.0	24.2	48.0	-17.0

**Note: Result = Reading + Factor**

**Pease see Appendix 3 for plotted graphs.**



c) High frequency : 848.97 MHz

Operation Mode : TransmittingTest Date : OCT. 07, 1999Temperature : 25Humidity: 60 %

Frequency (MHz)	Reading (dBuV)		Factor (dB)	Result (dBuV)		Limit (dBuV)	Margin (dB)
	Va	Vb		Va	Vb		
0.4753	32.8	28.7	0.2	33.0	28.9	48.0	-15.0
0.5506	35.2	34.0	0.2	35.4	34.2	48.0	-12.6
1.8966	22.9	19.8	0.3	23.2	20.1	48.0	-24.8
3.3971	23.0	24.6	0.3	23.3	24.9	48.0	-23.1
12.6369	21.7	23.5	0.7	22.4	24.2	48.0	-23.8
21.4085	29.0	21.8	0.9	29.9	22.7	48.0	-18.1

**Note: Result = Reading + Factor**

d) Other Emission

Operation Mode : ChargerTest Date : DEC. 02, 1999Temperature : 25Humidity: 60 %

Frequency (MHz)	Reading (dBuV)		Factor (dB)	Result (dBuV)		Limit (dBuV)	Margin (dB)
	Va	Vb		Va	Vb		
0.4612	26.5	28.8	0.2	26.7	29.0	48.0	-19.0
0.7382	24.5	25.2	0.3	24.8	25.5	48.0	-22.5
1.6147	25.6	25.8	0.3	25.9	26.1	48.0	-21.9
1.8914	25.3	24.6	0.3	25.6	24.9	48.0	-22.4
4.8893	19.2	22.6	0.3	19.5	22.9	48.0	-25.1
6.9190	21.0	23.8	0.4	21.4	24.2	48.0	-23.8
25.3506	28.1	28.9	1.0	29.1	29.9	48.0	-18.1

**Note: Result = Reading + Factor****Pease see Appendix 3 for plotted graphs.*****Plese see Exhibit F for Conducted Emission measurement Photos.***

#### 9.4 Conducted Measurement Equipment

The following test equipment are used during the conducted test .

<b>Equipment</b>	<b>Manufacturer</b>	<b>Model No.</b>	<b>Next Cal. Date</b>
RF Test Receiver	Rohde and Schwarz	ESH3	JAN. 10, 2001
Spectrum Monitor	Rohde and Schwarz	EZM	N.C.R.
Line Impedance Stabilization network	Kyoritsu	KNW-407	DEC. 01, 2000
Plotter	Hewlett-Packard	7440A	N/A
Shielded Room	Riken		N.C.R.

**Appendix 1.....Conducted RF Outout Power**

**Appendix 2.....Emission Bandwidth**

**Appendix 3.....Conducted Emission at Antenna Terminal**

**Appendix 4.....Power Line Conducted Emission**