

DATE	REVISION NUMBER	INITIALS	DESCRIPTION
08/10/06	245-01496-010	JC	Initial Design
12/01/06	245-01496-020	edward	changed note : improved sensitivity: 1 changed C51,C52,C39,C50 to 2.7pF; 2 changed C18 to 1uF ;C35 to 22pF ; improved EVM 1 changed L1=L2=5.1nH 2 changed C3 to 0.68pF; C37 to 1uF
12/15/06	245-01496-021	edward	improved EVM 1 changed L2 to 4.7nH 2 changed C20 to 22pF ;C21 to 12pF changed C37 to 2.7pF ;C3 to 0.7pF
12/26/06	245-01496-022	edward	improved ppm issue 1 changed C21 to 15pF 2 changed C3 to 0.75pF ;C17 to 0.2 pF
01/04/07	245-01496-023	edward	1 changed 32kbit eeprom to 16kbit
01/25/07	245-01496-024	edward	1 changed C21 to 12P
04/10/07	245-01496-040	edward	changed note : changed PCB layout to 040 C36=0.1uF C52=2.7p C56=2.2p C51=2.7p L4=3.0nH C13=1.5p C17 =1.8pC37=1.8p C35=0.1uFC23=2.2p C50=1nF C39=1nF L1=5.1nH L2=5.6nH Added R1=0 ohm C25=1nF C27=1nF
04/22/07	245-01496-041	edward	removed :C25,C27 C21=15P C17=1.5P C16=1P C48=2.2P C37=2.2P C50=1.8P C44=1000P C45=1000P C35=1000P C18=1000P C36=1000P L2=5.6nH
05/09/07	ZCOM	Chris	1 changed C21 to 12P(Adjust frequency deviation)
05/28/07	ZCOM	Chris	improved EVM 1 changed L1,L2 to 4.7nH +/-0.1nH(Adjust Balun matching)

MB55-802.11b/g Mini PCI Reference Design

Mini PCI-Title Page

245-01496-041

 智捷科技股份有限公司 Z-com, Inc.		
Sheet Title		
Titel and Rev Page		
Size B	Document Number XG-624	Rev V0.2
Data : Thursday, June 28, 2007		Sheet 1 / 3

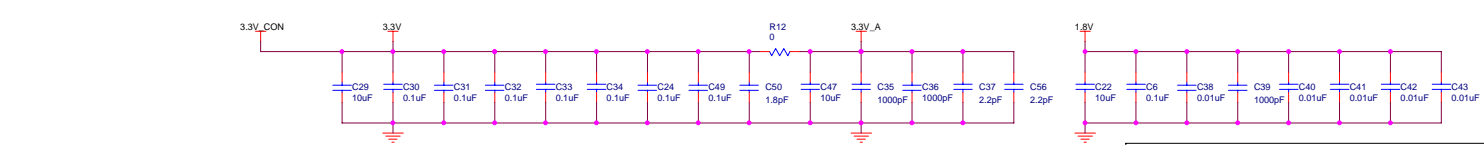
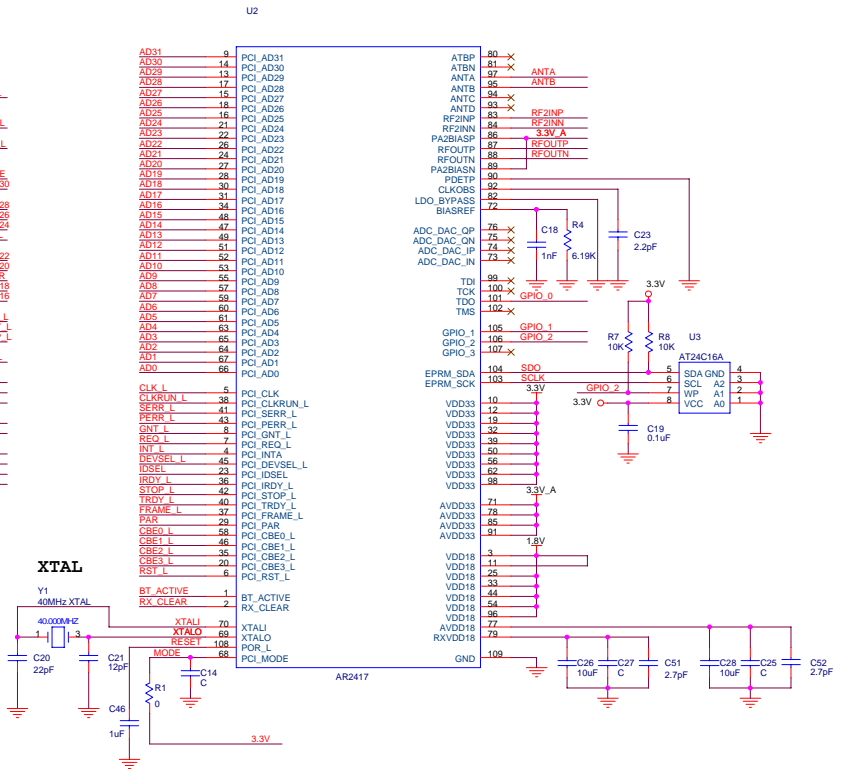
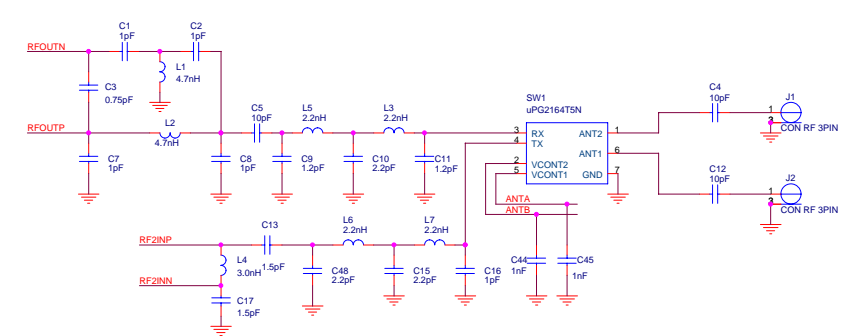
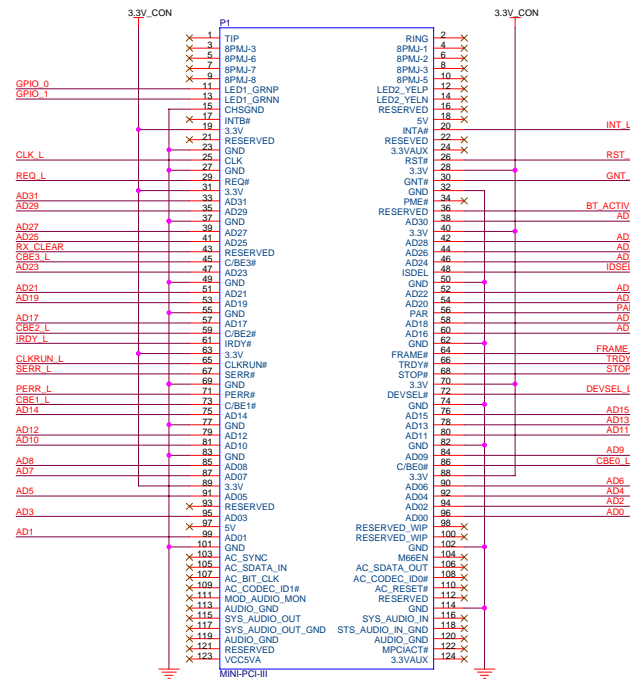

ZCOM 智捷科技股份有限公司 Z-com, Inc.		
Sheet Title		
Circuit		
Size	Document Number	Rev
C	XG-624	V0.2
Data	Thursday, June 28, 2007	Sheet 3 / 3