

VG300 Radio Module
Factory Tune-up Procedure 1.0

November 16,1999

Table of Contents

1.0 PURPOSE	3
2.0 SCOPE	3
3.0 RELATED DOCUMENTS	3
4.0 OVERVIEW	4
4.1 Introduction	4
4.2 VG300 Radio Reference Solution Architecture	5
5.0 FACTORY TUNE-UP PROCEDUES	6
5.1 TESTEQUIPMENT REQUTREMENT	6
5.2.1 INTRODUCTION	7
5.2.2 PROCEDURE	7
5.3 TUNING PROCEDURE	8
5.3.1INTRODUCTION	
5.3.2 PROCEDURE	
6.0 VG300 RADIO MODULE DATA SHEET	

1.0 Purpose

The purpose of this document is to provide the necessary information to allow a test person to tune-up a VG300 Radio Module in conjunction with the VG300 CDPD baseband card.

2.0 Scope

This document will provide a top level description of the VG300 Radio Module. For the purposes of this factory tune-up procedure it will be assumed that the VG300radio module is used with the VG300 CDPD baseband card.

3.0 Related Documents

There are a number of related documents which are helpful when using this manual. They include the following

- a) VG300 CDPD User's Manual
- b) Topaz CDPD Radio Interface Chip Data Sheet
- c) CDPD System Specification, Book III
- d) VG300 Radio Circuitry Description 1.0

The VG300 CDPD User's Manual provides the necessary information to operate a CDPD-MES modem. The Topaz CDPD Radio Interface Chip Data Sheet provides same type of information for the Topaz CDPD Radio Interface. Book III of the CDPD System Specification provides the detailed requirements of the CDPD network system. The VG300 Radio Circuitry Description 1.0 provides information on the circuits relevant to FCC part 22 certification.

4.0 Overview

4.1 Introduction

Figure 4-1 shows the elements of the CDPD network. This network provides packetized data communications over the same channels used by the AMPS cellular voice system. It does this by using unused channels or channels dedicated to CDPD. See the CDPD Specification for more information.

The primary components are the MES (Mobile End System) the MDBS(Mobile Data Base Station) and the MDIS(Mobile Data Intermediate System). The M-ES is the only mobile component of the CDPD network. It uses a radio to communicate over the airlink interface to a MDBS. As the MES roams, hand-offs will occur between MDBSs.

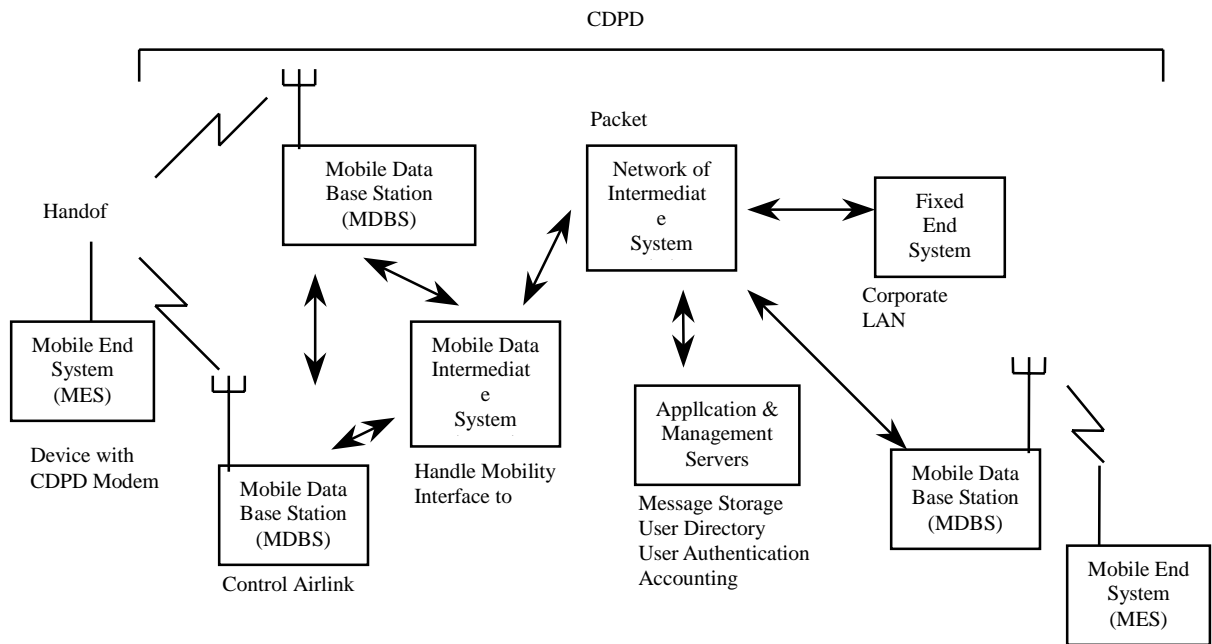

Figure 4-1 CDPD Network

The MES communicates to both the MDBS and the MDIS but at different layers of the CDPD protocol. The MDIS is also connected to a wired backbone which can provide internet access, transportation to a corporate LAN, or another M-ES (with the help of another MDBS)

VG300 is a CDPD MES which will operate in such a CDPD network environment.

4.2 VG300 Radio Module Circuit Architecture

The VG300 radio module is the MES' transceiver portion of the CDPD Network. Figure 4-2 presents the block diagram of VG300 radio.

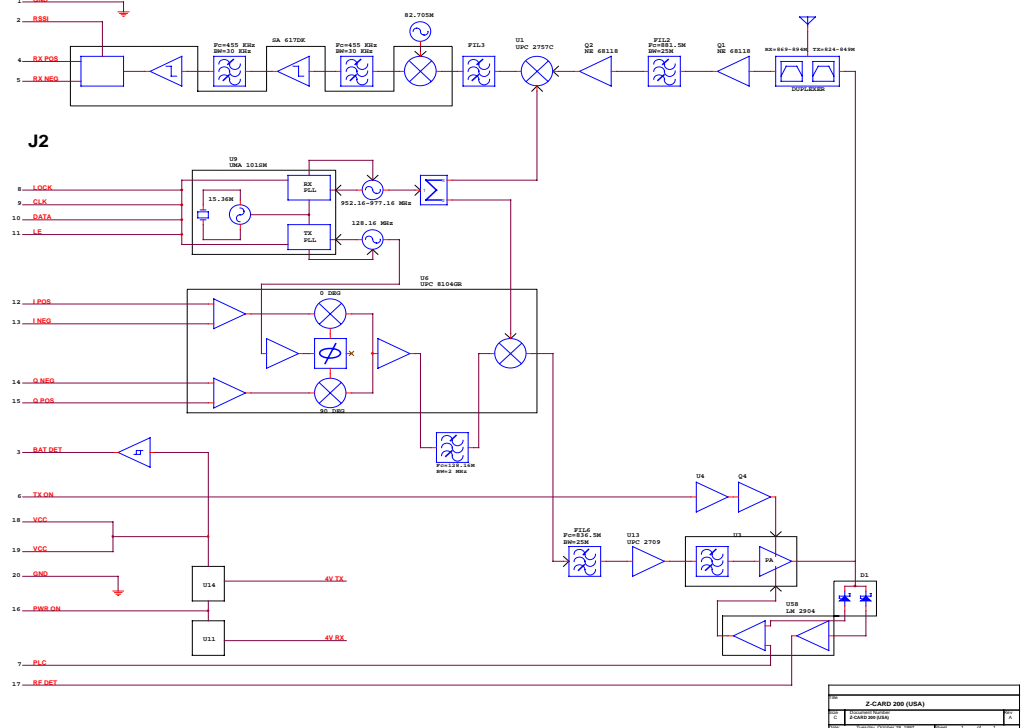

Figure 4-2 VG300 Radio Block Diagram

The radio transceiver provides full-duplex operation with a transmitter architecture employing vector modulation of an offset loop oscillator and a receiver utilizing a dual-conversion, heterodyne architecture. The radio is designed to meet CDPD specifications and to be FCC compliant . Within the context of the VG300 CDPD Reference Solution, the radio is controlled by the Ruby II Communications Processor. It also passes the signals to and from the Topaz radio interface IC, and transmits and receives radio signals to and from the MDBS over the airlink interface . For further information see the Ruby II Communications Processor and Topaz CDPD Radio Interface IC Data Sheets.

The VG300 Radio module interface is shown in Figure 4-3 . The VG300 Radio provides vector controlled modulation. The VG300 radio interface has a radio On/Off Control which is controlled by the Topaz CDPD Radio Interface Chip Port registers. The VG300 radio TX Power is controlled by the Topaz CDPD Radio Interface Chip TX Power D/A .

A micro controller (Ruby)which resides in VG300 baseband PCMCIA card is used to control the VG300 radio channel select synthesizers with configuration and synthesizer commands.

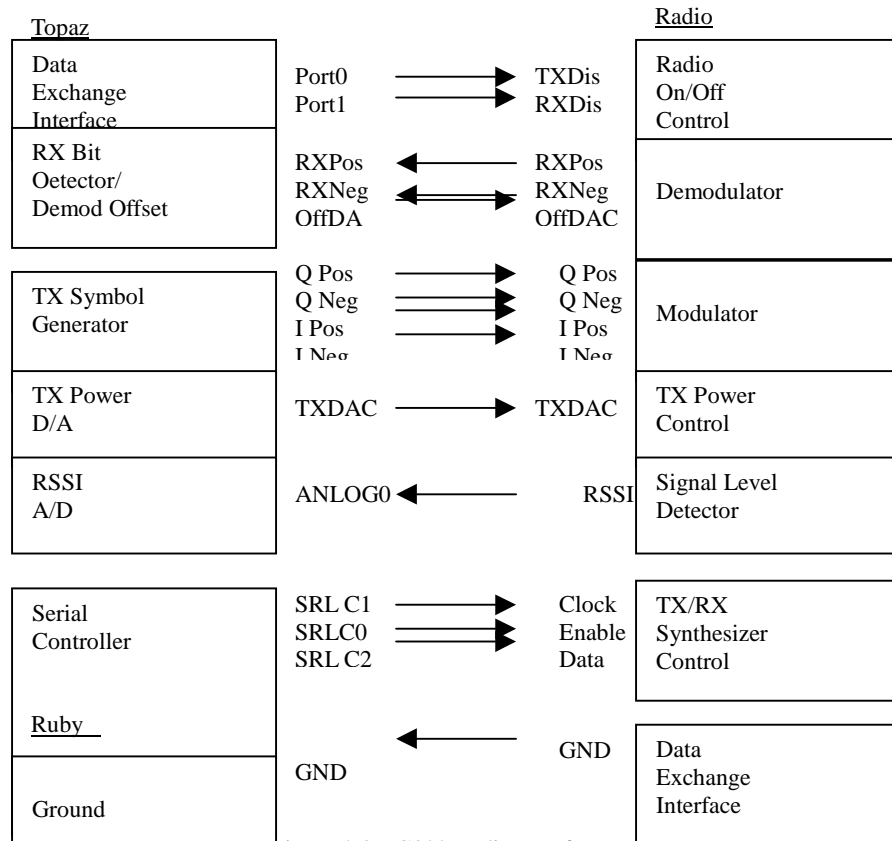

Figure 4-3 VG300 Radio Interface

5.0 Factory Tune-up procedures

All data taken should be recorded on a copy of sample data sheet in section 6.

5.1 Test Equipment Requirements

The following test equipment(or equivalents) are required to properly tune the VG300 Radio.

1. Tested VG300 baseband assembly with baseband/radio interface cable.
2. Personal computer with the RFTEST test software and PCMCIA prot.
3. HP E3610A DC power supply.
4. HP.8595E spectrum analyzer.
5. HP 8643A synthesized signal generator
6. HP 53131A universal counter w/option 010 high stability oven.
7. Fluke 87 RMS multimeter.
8. SMA compatible 10 dB 50 resistive attenuator.
9. Tektronix TDS 540A 4 channel digitizing oscilloscope.

5.2 Pre-tuning procedure

5.2.1 Introduction

This section describes the steps to take before the actual alignment of the radio should begin. The effort in this section is to visually inspect the assembled radio and measure the resistance between the three power supply positions and ground, and power on the radio to ensure proper power consumption.

5.2.2

1. Visually inspect the radio to verify all components have been installed.
2. Measure the resistance between the +5V supply input on J2 pin 18,19 and ground.
Resistance J2, 18, 19to GND ____ OHM
typically 2M OHM
3. Measure the resistance between receiver power and ground. ____ OHM
Resistance U11_4 to GND
typically = 286 OHM
4. Measure the resistance between the transmit power and ground. ____ OHM
Resistance U14-4 to GND
typically = 858 OHM

5.If values in steps 2-4 are off by more than 20% there may be a problem and the unit should not be powered on.

6.Power on the radio with the receive and the transmit circuitry selected and the transmitter inhibited (set J2-17 transmit control voltage=0V). Measure the supply current.

Supply Current _____mA
Typically 100mA

5.3 Tuning Procedure

5.3.1 Introduction

This section describes the procedure required to manually align the transmitter and receiver circuitry. The 128.16 MHz VCO is used to drive the quadrature modulator circuit. It is necessary to tune the TCXO (U10) to align the 128.16 MHz VCO so that it will oscillate at 128.16 MHz with the proper tuning voltage at D1. D1 is varactor (voltage variable capacitor) that is used to automatically control the frequency of oscillation of the 128.16 MHz VCO. The transmitter accuracy is then measured following alignment of the 128.16 MHz VCO because this is a convenient time to make this measurement. The automatic power vs. control voltage curve is developed while in this set up also. The quadrature demodulator's tank circuit similarly needs manual tuning to get the center frequency of the discriminator close to final operation. Avaractor is then used to automatically make very fine adjustments.

5.3.2 Procedure

Transmitter alignment

- 1.Connect the antenna port of the radio to 10 dB resistive attenuator and then to a calibrated spectrum analyzer turned to 837.6 MHz with a span of 100kHz. Power on the radio. Tune the radio to channel 420. This sets the radio to receive at 882.6 MHz and transmit at 837.6 MHz.
- 2.Enable the transmitter with 0 second switching time, the power level set to 7, and the modulation set to alternating 1s and 0s. this will enable the transmitter to transmit at its lowest output power level with modulation that puts the carrier frequency at the center of the transmitted channel and with an output power level of +8 dBm +2dB/-4Db. **Note:** power measurement made with the spectrum analyzer will be 10 dB lower than actual power levels.

3. Vary control screw of TCXO (U10) until the measured frequency at TP 13 is 128.1600MHz.
4. Run the automated power vs. TXDAC control voltage routine. This varied the power amp control voltage, measures the output power of the transmitter and determines the best fit valued for the transmitter control voltages that meet the CDPD class 3 MES devices. These values are then saved to a file that is later downloaded into the memory of the baseband board that will be used with this radio.
5. Set the transmitter to pseudo-random data and transmit full power (level 0) and monitor the supply current.

Supply current mA
(typically 540 Ma)

6. Change the transmit modulation to Vmid (no modulation), connect the antenna port to the frequency center and verify the output frequency accuracy is within 837.6MHz 2074Hz(2.5PPM). at room temperature the frequency should be specification over temperature and voltage variations.

Frequency mA

Receiver alignment

Note: the transmitter should be disabled during this test!

1. Power on the radio. Tune the radio to channel 420. This sets the radio to receive at 882.6MHz.
2. Connect the antenna port of the radio to the synthesized signal generator tuned to 882.6MHz with -60dBm output power and the FM modulation set to 4.8 kHz peak deviation and 9.6 kHz rate.
3. Connect J2-4 to an oscilloscope. Vary L5 until the amplitude reaches highest peak. This is the best receiving condition.

6.0 Guide Radio Data Sheet

Date

Serial Number

Pre-tune Procedure

1. Visual inspection of components.(check)
2. Resistance J2-18,19 to GND. (typically=2M OHM)
3. Resistance U11-4 to GND. (typically=286 OHM)
4. Resistance U14-4 to GND. (typically=858k)
5. Supply Current
RX and TX, no power amp (typically=80mA)

Truing Procedure

Transmitter Alignment

- 1.transmitter full power supply current. (typically=540mA) _____mA
- 2.frequency accuracy (837.6MHz 1000Hz).
_____MHz