

## TEST REPORT

**Product Name** : IEEE 802.11 b/g WLAN MiniPCI Card

**Model Number** : XG-602MB

**FCC ID** : M4Y-0XG602

**Applicant** : Z-Com, Inc.

**Address** : 7F-2, No. 9. Prosperity RD. I Science-Based  
Industrial, Park Hsinchu, 300 Taiwan

**Received Date** : April 27, 2005

**Tested Date** : August 18 ~ September 01, 2004 ;  
April 27 ~ May 05, 2005

Issued by

**Compliance Certification Services Inc.  
Hsinchu Lab.**

Rm. 258, Bldg. 17, NO.195, Sec.4 Chung HsingRd.,  
ChuTung Chen, Hsinchu, Taiwan 310, R.O.C

**TEL: (03) 591-8012**

**FAX: (03) 582-5720**

Notes :

1. This report will be invalid if duplicated or photocopied in part.
2. This report refers only to the specimen(s) submitted to testing, and be invalid as seperately used.
3. This report is invalid without examination stamp and signature of this institute.
4. The tested specimen(s) will be preserved for thirty days from the data issued.
5. The report must not be used to claim product certification, approval, or endorsement by NVLAP, NIST, or any agency of the federal government.
6. **This report is modified from ER04-08-040.**



# Test Report Certification

**Product Name** : IEEE 802.11 b/g WLAN MiniPCI Card  
**Model Number** : XG-602MB  
**FCC ID** : M4Y-0XG602  
**Applicant** : Z-Com, Inc.

## Measurement Standard :

FCC 47 C.F.R. Part 15, Subpart B and Subpart C (2004)  
ANSI C63.4 (2003)

**Tested By** : Vincent Chen, **Date** : May 11, 2005  
(Vincent Chen)

**Approved By** : C.F. Wu, **Date** : May 11, 2005  
(C.F. Wu, Manager)



WE HEREBY CERTIFY THAT: The measurements shown in the attachment were made in accordance with the procedures indicated, and the energy emitted by the equipment was found to be within the limits applicable. We assume full responsibility for the accuracy and completeness of these measurements and vouch for the qualifications of all persons taking them.



**TABLE OF CONTENTS**

TITLE	PAGE NO.
<b>1. GENERAL INFORMATION .....</b>	<b>5</b>
1.1 General Statement.....	5
1.2 General Description of EUT & Power.....	5
1.3 Description of Peripherals.....	6
1.4 EUT & Peripherals Setup Diagram.....	6
1.5 EUT Operating Procedure.....	7
1.6 Description of Laboratory.....	7
1.7 Summary of Test Results.....	8
<b>2. CONDUCTED POWERLINE TEST.....</b>	<b>9</b>
2.1 Test Equipments .....	9
2.2 Test Setup .....	9
2.3 Conducted Power Line Emission Limit.....	10
2.4 Test Procedure .....	10
2.5 Uncertainty of Conducted Emission .....	10
2.6 Conducted RF Voltage Measurement.....	11-18
2.7 Photos of Conduction Test.....	19-20
<b>3. RADIATED EMISSION TEST .....</b>	<b>21</b>
3.1 Test Equipments .....	21
3.2 Test Setup .....	21
3.3 Radiation Limit.....	22
3.4 Test Procedures.....	23
3.5 Uncertainty of Radiated Emission .....	23
3.6 Radiated RF Noise Measurement .....	24-61
3.7 Photos of Open Site .....	35-66
<b>4. 6dB BANDWIDTH MEASUREMENT .....</b>	<b>35</b>
4.1 Test Equipments .....	35
4.2 Test Setup .....	35
4.3 Limits of 6dB Bandwidth Measurement.....	35
4.4 Test Procedure .....	35
4.5 Uncertainty of Conducted Emission .....	35
4.6 Test Results.....	35
4.7 Photo of 6db Bandwidth Measurement.....	35-70



**TABLE OF CONTENTS**

TITLE	PAGE NO.
<b>5. MAXIMUM PEAK OUTPUT POWER .....</b>	<b>35</b>
5.1 Test Equipments .....	35
5.2 Test Setup .....	35
5.3 Limits of Maximum Peak Output Power .....	35
5.4 Test Procedure .....	35
5.5 Uncertainty of Conducted Emission .....	35
5.6 Test Results.....	35
<b>6. POWER SPECTRAL DENSITY MEASUREMENT .....</b>	<b>35</b>
6.1 Test Equipments .....	35
6.2 Test Setup .....	35
6.3 Limits of Power Spectral Density Measurement .....	35
6.4 Test Procedure .....	35
6.5 Uncertainty of Conducted Emission .....	35
6.6 Test Results.....	35
6.7 Photo of Power Spectral Density Measurement .....	35-76
<b>7. BAND EDGE MEASUREMENT .....</b>	<b>35</b>
7.1 Test Equipments .....	35
7.2 Test Setup .....	35
7.3 Limits of Band Edge Emissions Measurement .....	35
7.4 Test Procedure .....	35
7.5 Uncertainty of Conducted Emission .....	35
7.6 Test Results.....	35-79
7.7 Photo of Band edge Measurement .....	35-83
<b>8. ANTENNA REQUIREMENT .....</b>	<b>35</b>
8.1 Standard Applicable.....	35
8.2 Antenna Connected Construction .....	35
<b>9. RF EXPOSURE EVALUATION .....</b>	<b>35</b>
9.1 Friis Formula.....	35
9.2 EUT Operating Condition.....	35
9.3 Test Result of RF Exposure Evaluation.....	35
9.3.1 Antenna Gain .....	35
9.3.2 Output Power into Antenna & RF Exposure Evaluation Distance .....	35



## 1. GENERAL INFORMATION

### 1.1 General Statement

MEASUREMENT DEVIATION : Comply with standard in full

TRACEABILITY : This test result is traceable to National or International std.

### 1.2 General Description of EUT & Power

<b>Product Name</b>	IEEE 802.11 b/g WLAN MiniPCI Card
<b>Model Number</b>	XG-602MB
<b>Frequency Range</b>	2400MHz to 2483.5MHz
<b>Frequency Channel</b>	2412MHz + 5×n (MHz), n=0, 1, 2,.....10
<b>Channel Number</b>	11
<b>Channel Spacing</b>	5MHz
<b>Air Data Rate</b>	54Mbps (802.11g Mode), 11Mbps(802.11b Mode)
<b>Type of Modulation</b>	802.11b : DSSS(CCK, DQPSK, DBPSK) 802.11g : OFDM(64QAM, 16AQM, QPSK, BPSK)
<b>Frequency Selection</b>	by software / firmware
<b>EUT Description</b>	2.4GHz (Direct Sequence Spread Spectrum and Orthogonal Frequency Division Multiplex) Data Transceiver for WLAN application
<b>Antenna Type</b>	(1) Pifa Antenna, Antenna Gain : 3dBi (2) PCB Antenna, Antenna Gain : 2.8dBi
<b>Power Source</b>	3.3VDC (From Notebook)

### 1.3 Description of Peripherals

#### (1) Notebook PC

MANUFACTURER : DELL  
MODEL NUMBER : PP01L  
SERIAL NUMBER : CN-09C748-48155-1AP-6630  
FCC ID : DOC  
INPUT POWER : 20VDC/3.5A

#### Adapter

MANUFACTURER : DELL  
MODEL NUMBER : ADP-70EB  
INPUT POWER : 100-240V, 1.5A, 70W  
OUTPUT POWER : 20VDC/3.5A

#### (2) Printer

MANUFACTURER : HP CORP.  
MODEL NUMBER : C8952D  
SERIAL NUMBER : CN29B181H7  
INPUT POWER : 100-240VAC, 50/60Hz, 0.7A  
SIGNAL CABLE : Shielded, Undetachable, 1.8m

### 1.4 EUT & Peripherals Setup Diagram

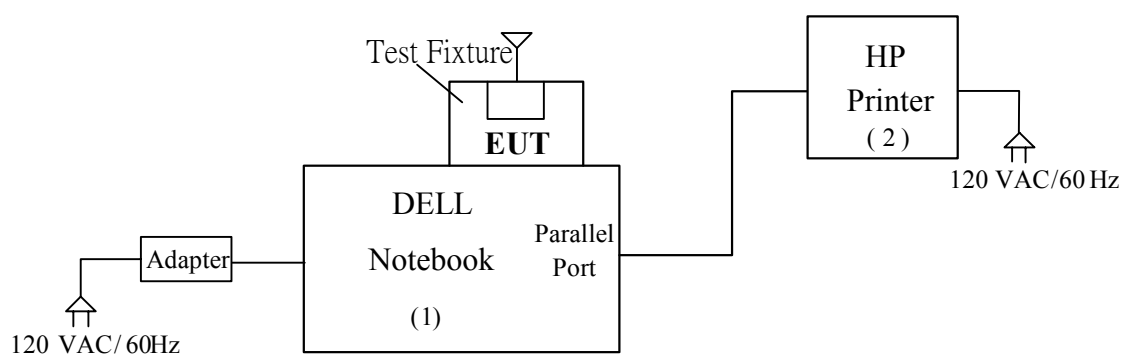

The indicated numbers (1)(2)....., please refer to item 1.3



## 1.5 EUT Operating Procedure

1. Run the test control software “ Prism Engineering Tool ” .
2. Available Adapters List “ select PRISM 802.11 a/g Adaptor (38696) ” .  
Product select : Select Javelin.
3. Press “ Open Adaptor ” .
4. To select channel 1, 6, 11 : TX Rate 11MB for 802.11b mode.  
TX Rate 6MB for 802.11g mode
5. Continuous TX for TX mode.  
Promisc RX for RX mode.

## 1.6 Description of Laboratory

### SITE DESCRIPTION

FCC Certificate NO. : 90585  
BSMI Certificate NO. : SL2-IN-E-0002  
NVLAP Lab Code : 200118-0  
CNLA Certificate NO. : CNLA-ZL97018E  
VCCI Certificate NO. : R-1189, C-1250  
TÜV Rheinland Certificate NO. : 10008375

NAME OF SITE : Compliance Certification Services Inc. Hsinchu Lab.  
SITE LOCATION : Rm.258, Bldg.17, NO.195 , Sec. 4, Chung Hsing Rd.,  
Chu-Tung Chen. Hsin-Chu, Taiwan 310 R.O.C.



## 1.7 Summary of Test Results

The EUT has been tested according to the following specifications :

<b>APPLIED STANDARD : FCC 47 C.F.R. Part 15, Subpart B and Subpart C</b>			
<b>Standard Section</b>	<b>Test Item and Limit</b>	<b>Result</b>	<b>REMARK</b>
15.107 15.207	AC Power Conducted Emission Limit : Sec 15.107	PASS	Meet the requirement of limit
15.247(a)(2)	Spectrum Bandwidth of a Orthogonal Frequency Division Multiplex System Limit : 6dB bandwidth > 500KHz	PASS	Meet the requirement of limit
15.247(b)	Maximum Peak Output Power Limit : max. 30dBm	PASS	Meet the requirement of limit
15.109 15.205 15.209	Transmitter Radiated Emissions Limit : Table 15.209	PASS	Meet the requirement of limit
15.247(e)	Power Spectral Density Limit : max. 8dBm	PASS	Meet the requirement of limit
15.247(d)	Out of Band Emission and Restricted Band Radiation Limit:20dB less than peak value of fundamental frequency Restricted band Limit:Table 15.209	PASS	Meet the requirement of limit





## 2. CONDUCTED POWERLINE TEST

### 2.1 Test Equipments

The following test equipments are used during the conducted powerline tests :

Manufacturer or Type	Model No.	Serial No.	Date of Calibration	Calibration Period	Remark
HP SPECTRUM ANALYZER & DISPLAY	8594E	3801A05627	April 28, 2005	1 Year	PRETEST
SOLAR ISOLATION TRANSFORMER	7032-1	N/A	N/A	N/A	FINAL
EMCO L.I.S.N.	3850/2	9311-1025 9401-1028	January 10, 2005 For Characteristic impedance	1 Year	FINAL
			May 18, 2004 For Insertion loss		
R & S TEST RECEIVER	ESHS 30	838550/003	February 21, 2005	1 Year	FINAL
KEENE SHIELDED ROOM	5983	No.1	N/A	N/A	FINAL
R & S PULSE LIMIT	EHS3Z2	357.8810.52	July 10, 2004	1 Year	FINAL
N TYPE COAXIAL CABLE	-----	-----	July 10, 2004	1 Year	FINAL
50Ω TERMINATOR	-----	-----	July 10, 2004	1 Year	FINAL

### 2.2 Test Setup

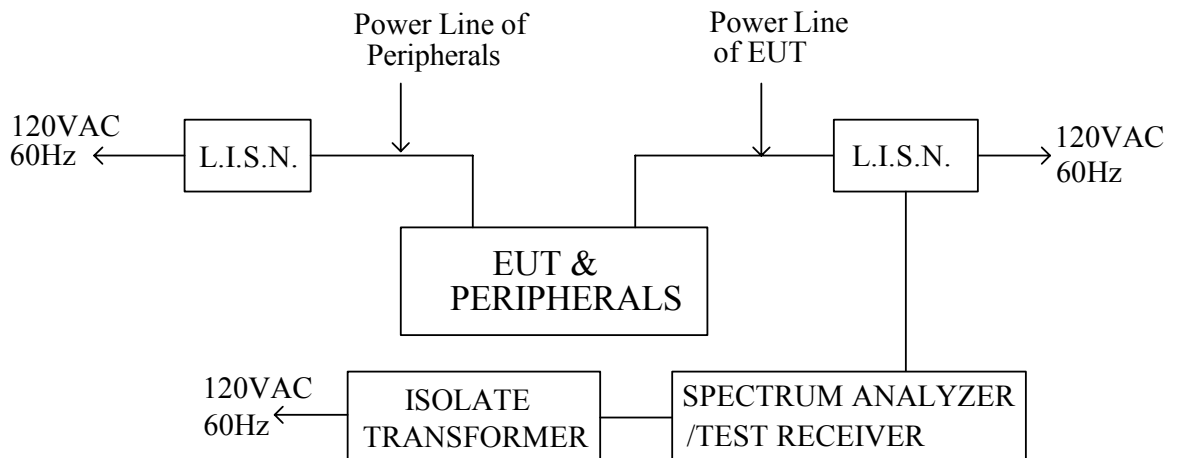



## 2.3 Conducted Power Line Emission Limit

For unintentional device, according to § 15.107(a) Line Conducted Emission Limits is as following :

Frequency (MHz)	Maximum RF Line Voltage (dB $\mu$ v)			
	CLASS A		CLASS B	
	Q.P.	Ave.	Q.P.	Ave.
0.15 - 0.50	79	66	66-56	56-46
0.50 - 5.00	73	60	56	46
5.00 - 30.0	73	60	60	50

For intentional device, according to § 15.207(a) Line Conducted Emission Limit is same as above table.

## 2.4 Test Procedure

The test procedure is performed in a 12ft×12ft×8ft(L×W×H) shielded room. The EUT along with its peripherals were placed on a 1.0m(W)× 1.5m(L) and 0.8m in height wooden table and the EUT was adjusted to maintain a 0.4 meter space from a vertical reference plane. The EUT was connected to power mains through a line impedance stabilization network (LISN) which provides 50 ohm coupling impedance for measuring instrument and the chasis ground was bounded to the horizontal ground plane of shielded room. All peripherals were connected to the second LISN and the chasis ground also bounded to the horizontal ground plane of shielded room. The excess power cable between the EUT and the LISN was bundled. The power cables of peripherals were unbundled. All connecting cables of EUT and peripherals were moved to find the maximum emission.

## 2.5 Uncertainty of Conducted Emission

The uncertainty of conducted emission is  $\pm 2.1$  dB.



## 2.6 Conducted RF Voltage Measurement

The frequency spectrum from 0.15 MHz to 30 MHz was investigated. All emissions not reported are much lower than the prescribed limits.

<b>Company</b>	Z-Com, Inc.	<b>Test Date</b>	2004/08/19
<b>Product Name</b>	IEEE 802.11 b/g WLAN MiniPCI Card	<b>Test By</b>	Vincent Chen
<b>Model Name</b>	XG-602MB	<b>TEMP &amp; Humidity</b>	30°C, 60%

LINE

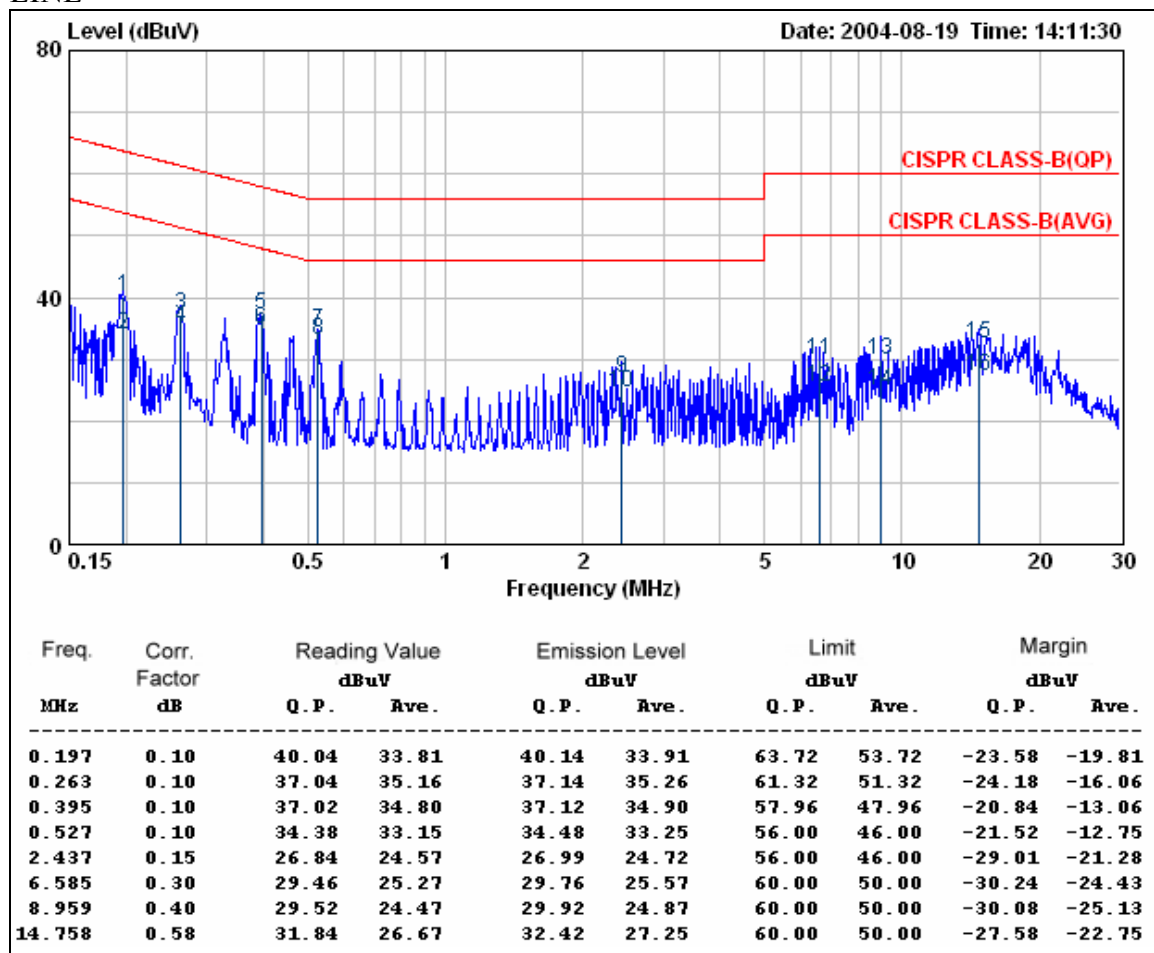

REMARKS :

1. Correction Factor = Insertion loss + cable loss
2. Margin value = Emission level – Limit value
3. For 802.11b mode, Antenna (1).
4. The EUT can be operated in transmitting, stand-by and receiving mode. After preliminary scan, EUT in transmitting mode has highest emission. The EUT was set in transmitting mode at final test to get the worst case test results.



The frequency spectrum from 0.15 MHz to 30 MHz was investigated. All emissions not reported are much lower than the prescribed limits.

<b>Company</b>	Z-Com, Inc.	<b>Test Date</b>	2004/08/19
<b>Product Name</b>	IEEE 802.11 b/g WLAN MiniPCI Card	<b>Test By</b>	Vincent Chen
<b>Model Name</b>	XG-602MB	<b>TEMP &amp; Humidity</b>	30°C, 60%

NEUTRAL

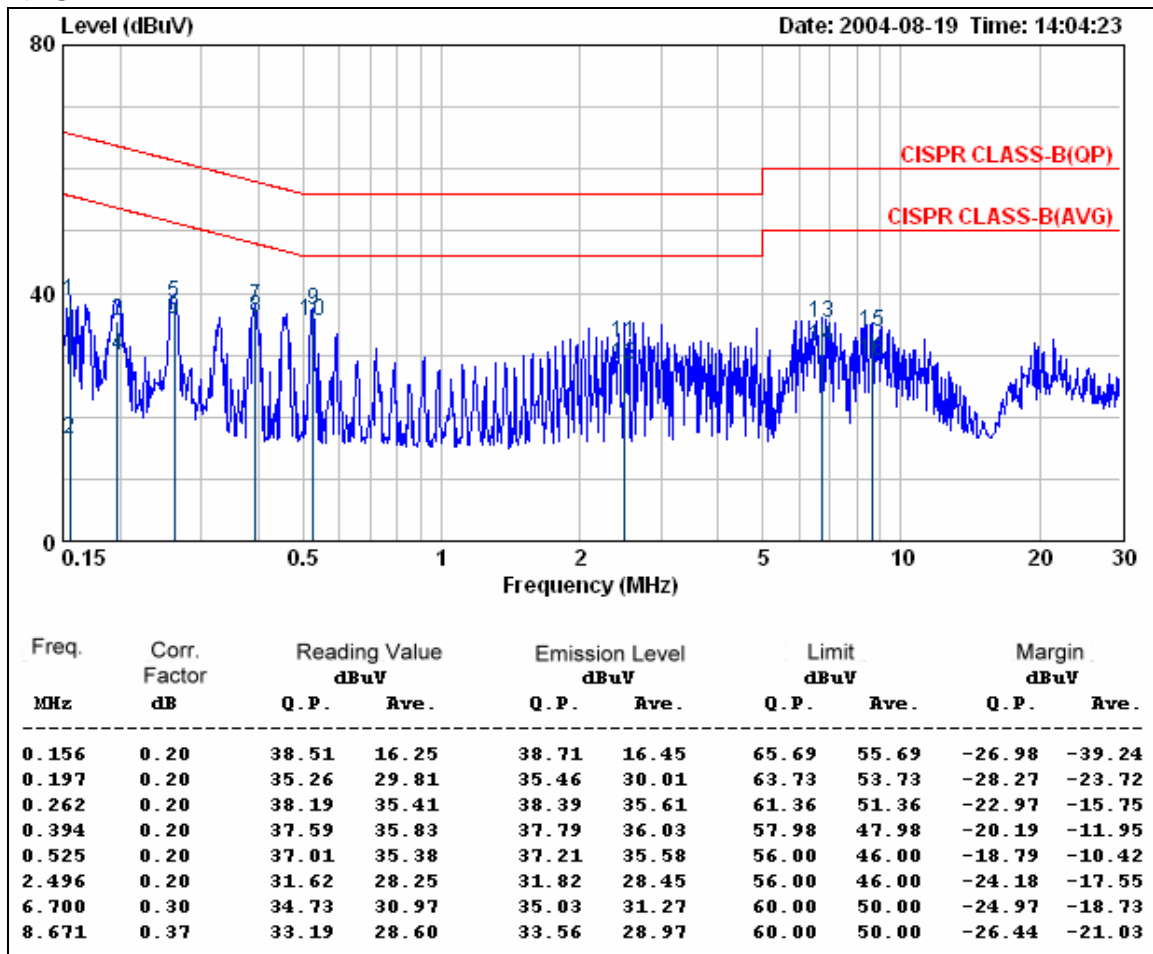

REMARKS :

1. Correction Factor = Insertion loss + cable loss
2. Margin value = Emission level – Limit value
3. For 802.11b mode, Antenna (1).
4. The EUT can be operated in transmitting, stand-by and receiving mode. After preliminary scan, EUT in transmitting mode has highest emission. The EUT was set in transmitting mode at final test to get the worst case test results.



The frequency spectrum from 0.15 MHz to 30 MHz was investigated. All emissions not reported are much lower than the prescribed limits.

<b>Company</b>	Z-Com, Inc.	<b>Test Date</b>	2004/08/19
<b>Product Name</b>	IEEE 802.11 b/g WLAN MiniPCI Card	<b>Test By</b>	Vincent Chen
<b>Model Name</b>	XG-602MB	<b>TEMP &amp; Humidity</b>	30°C, 60%

LINE

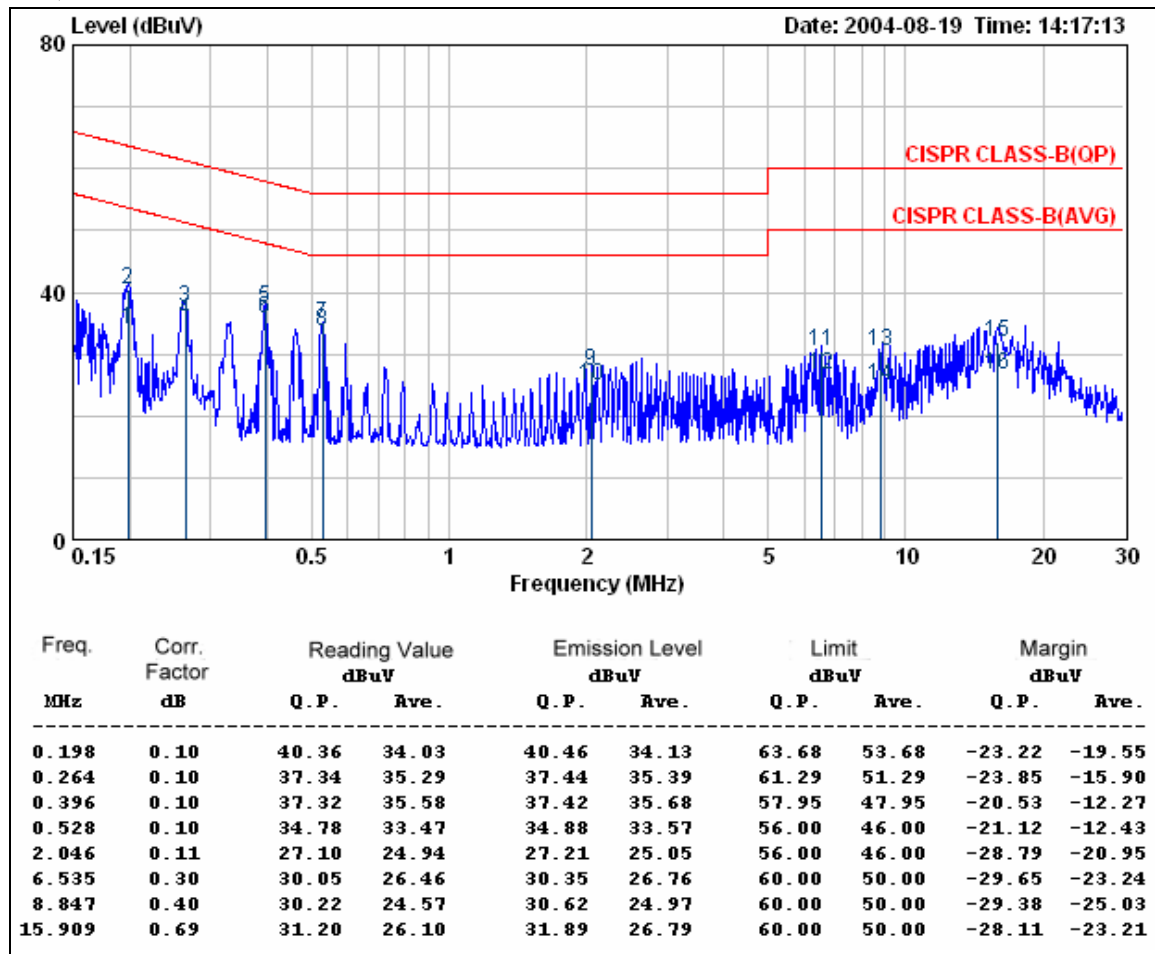

REMARKS :

1. Correction Factor = Insertion loss + cable loss
2. Margin value = Emission level – Limit value
3. For 802.11g mode, Antenna (1).
4. The EUT can be operated in transmitting, stand-by and receiving mode. After preliminary scan, EUT in transmitting mode has highest emission. The EUT was set in transmitting mode at final test to get the worst case test results.



The frequency spectrum from 0.15 MHz to 30 MHz was investigated. All emissions not reported are much lower than the prescribed limits.

<b>Company</b>	Z-Com, Inc.	<b>Test Date</b>	2004/08/19
<b>Product Name</b>	IEEE 802.11 b/g WLAN MiniPCI Card	<b>Test By</b>	Vincent Chen
<b>Model Name</b>	XG-602MB	<b>TEMP &amp; Humidity</b>	30°C, 60%

NEUTRAL

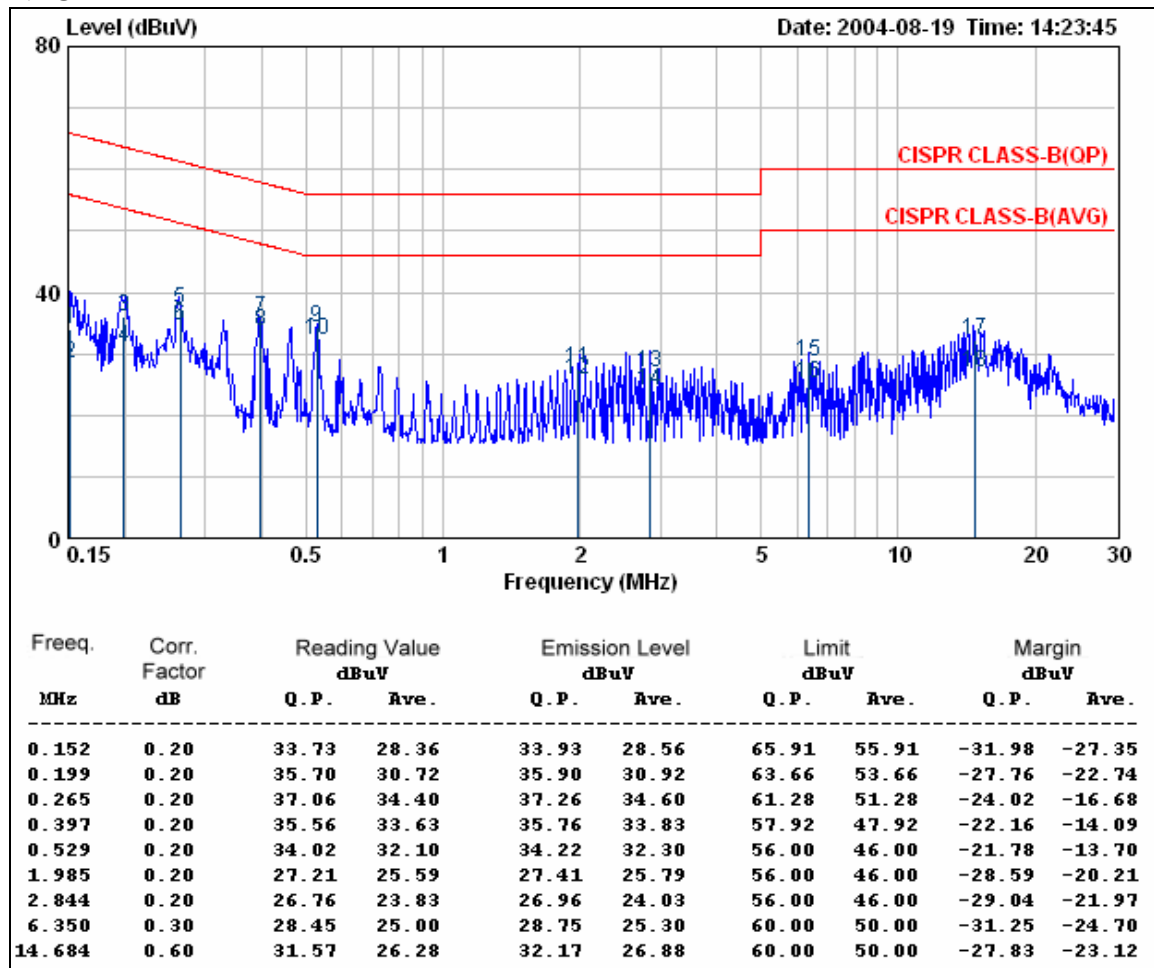

REMARKS :

1. Correction Factor = Insertion loss + cable loss
2. Margin value = Emission level – Limit value
3. For 802.11g mode, Antenna (1).
4. The EUT can be operated in transmitting, stand-by and receiving mode. After preliminary scan, EUT in transmitting mode has highest emission. The EUT was set in transmitting mode at final test to get the worst case test results.



The frequency spectrum from 0.15 MHz to 30 MHz was investigated. All emissions not reported are much lower than the prescribed limits.

<b>Company</b>	Z-Com, Inc.	<b>Test Date</b>	2005/05/05
<b>Product Name</b>	IEEE 802.11 b/g WLAN MiniPCI Card	<b>Test By</b>	Vincent Chen
<b>Model Name</b>	XG-602MB	<b>TEMP &amp; Humidity</b>	27.2°C, 64%

LINE

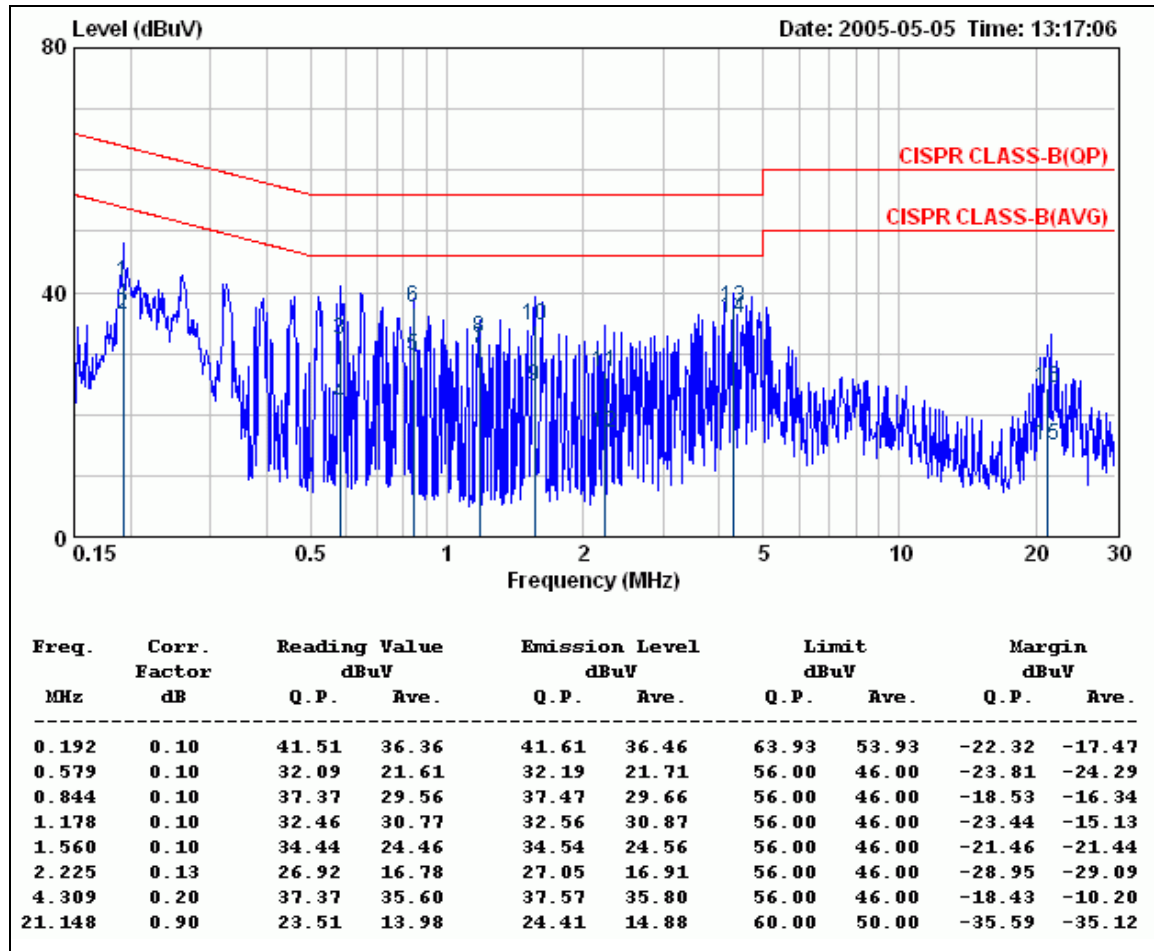

REMARKS :

1. Correction Factor = Insertion loss + cable loss
2. Margin value = Emission level – Limit value
3. For 802.11b mode, Antenna (2).
4. The EUT can be operated in transmitting, stand-by and receiving mode. After preliminary scan, EUT in transmitting mode has highest emission. The EUT was set in transmitting mode at final test to get the worst case test results.



The frequency spectrum from 0.15 MHz to 30 MHz was investigated. All emissions not reported are much lower than the prescribed limits.

<b>Company</b>	Z-Com, Inc.	<b>Test Date</b>	2005/05/05
<b>Product Name</b>	IEEE 802.11 b/g WLAN MiniPCI Card	<b>Test By</b>	Vincent Chen
<b>Model Name</b>	XG-602MB	<b>TEMP &amp; Humidity</b>	27.2°C, 64%

NEUTRAL

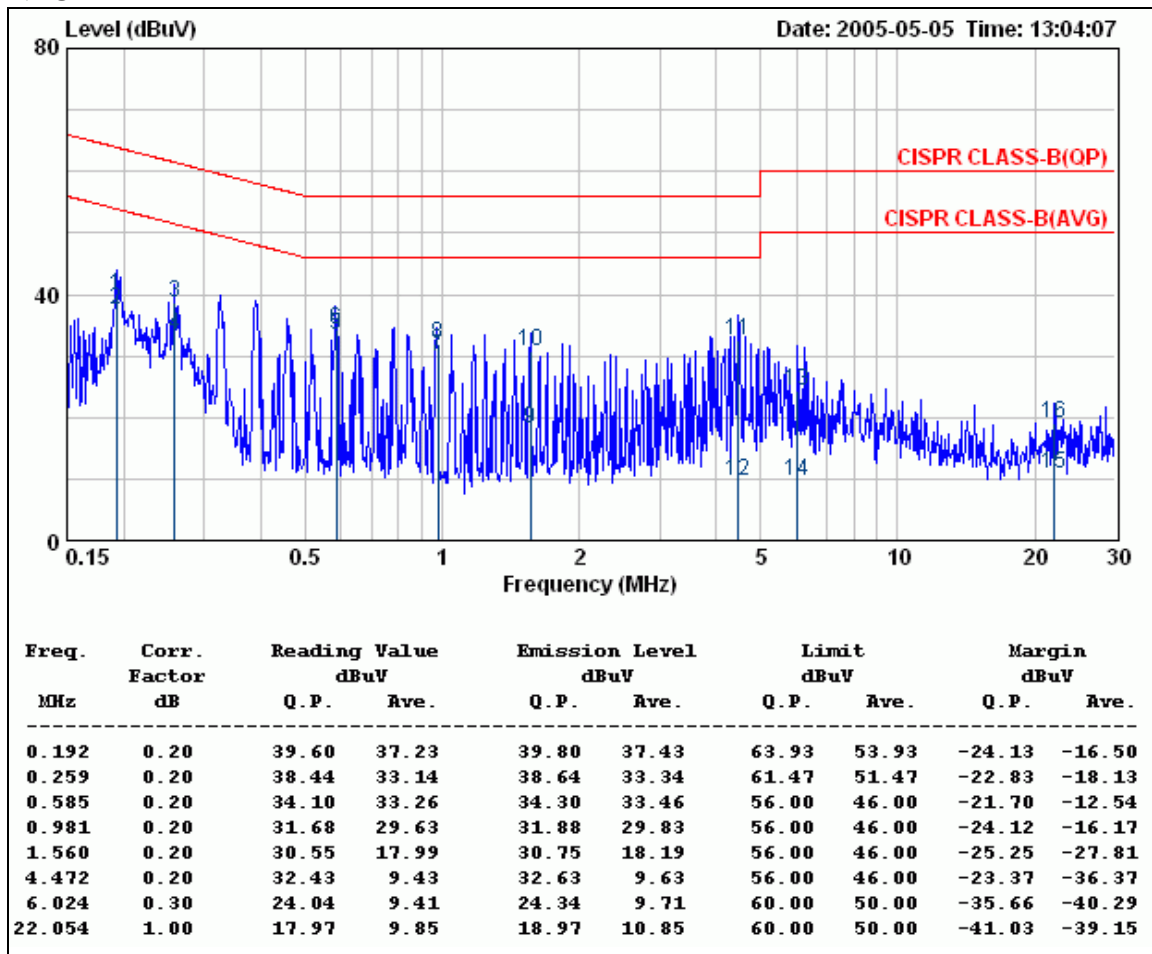

REMARKS :

1. Correction Factor = Insertion loss + cable loss
2. Margin value = Emission level – Limit value
3. For 802.11b mode, Antenna (2).
4. The EUT can be operated in transmitting, stand-by and receiving mode. After preliminary scan, EUT in transmitting mode has highest emission. The EUT was set in transmitting mode at final test to get the worst case test results.





The frequency spectrum from 0.15 MHz to 30 MHz was investigated. All emissions not reported are much lower than the prescribed limits.

<b>Company</b>	Z-Com, Inc.	<b>Test Date</b>	2005/05/05
<b>Product Name</b>	IEEE 802.11 b/g WLAN MiniPCI Card	<b>Test By</b>	Vincent Chen
<b>Model Name</b>	XG-602MB	<b>TEMP &amp; Humidity</b>	27.2°C, 64%

LINE

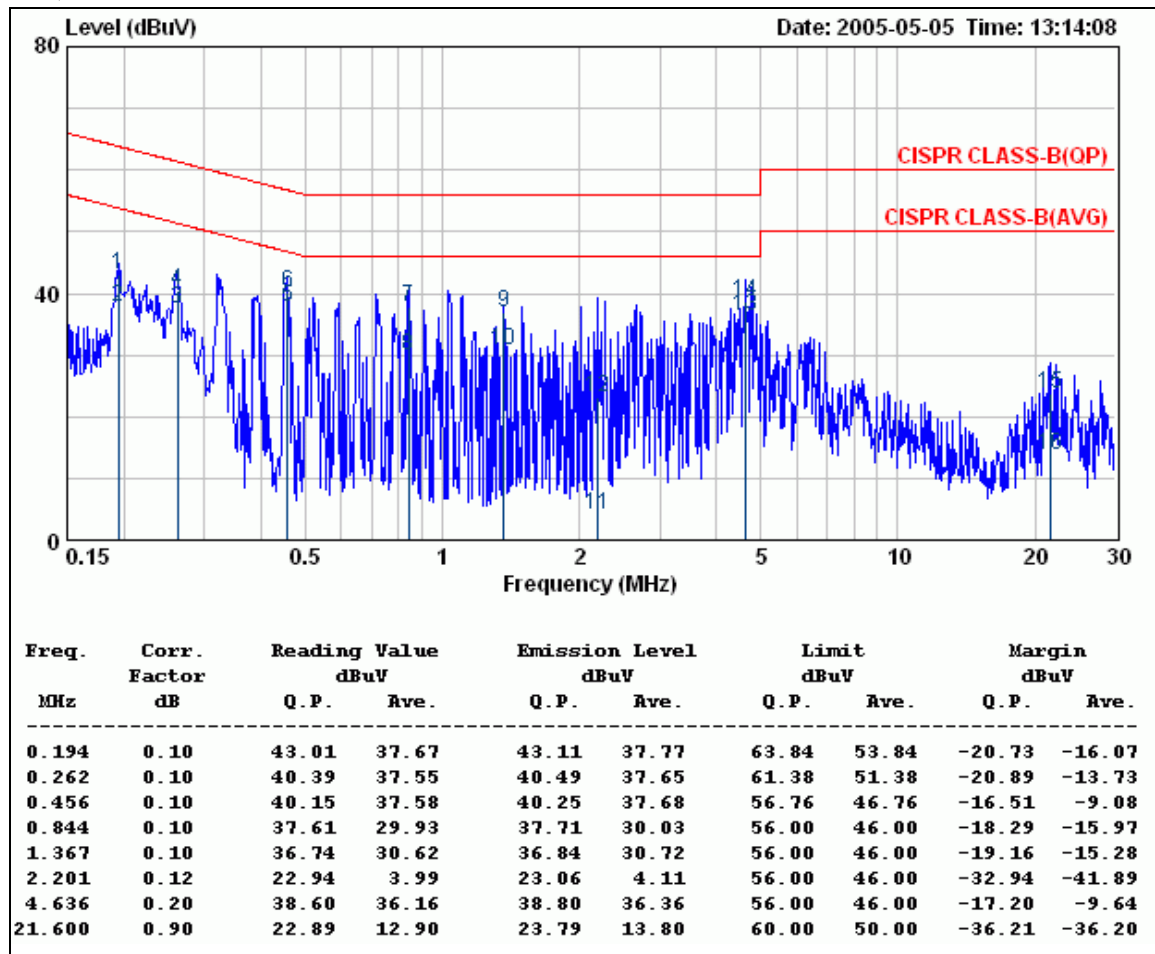

REMARKS :

1. Correction Factor = Insertion loss + cable loss
2. Margin value = Emission level – Limit value
3. For 802.11g mode, Antenna (2).
4. The EUT can be operated in transmitting, stand-by and receiving mode. After preliminary scan, EUT in transmitting mode has highest emission. The EUT was set in transmitting mode at final test to get the worst case test results.



The frequency spectrum from 0.15 MHz to 30 MHz was investigated. All emissions not reported are much lower than the prescribed limits.

<b>Company</b>	Z-Com, Inc.	<b>Test Date</b>	2004/08/19
<b>Product Name</b>	IEEE 802.11 b/g WLAN MiniPCI Card	<b>Test By</b>	Vincent Chen
<b>Model Name</b>	XG-602MB	<b>TEMP &amp; Humidity</b>	30°C, 60%

NEUTRAL

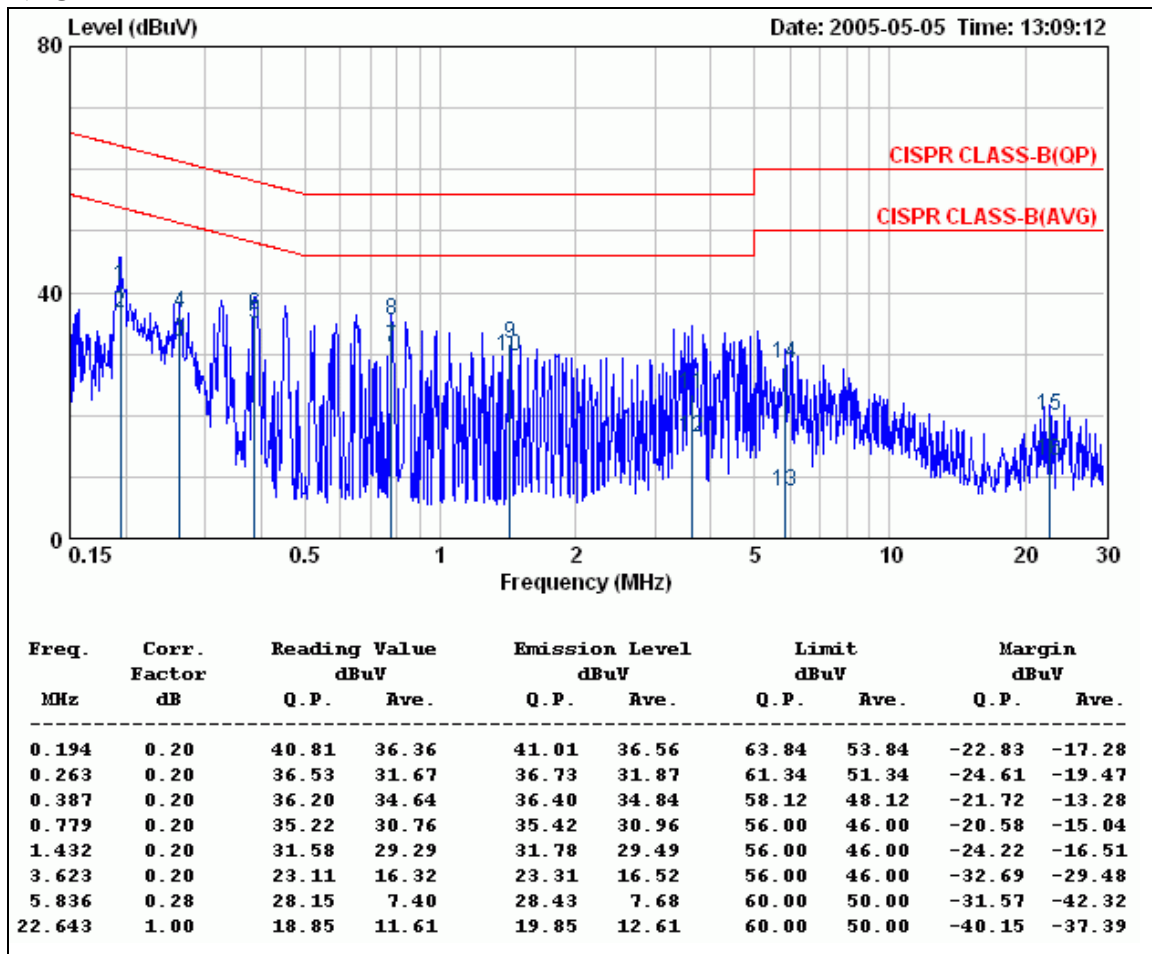

REMARKS :

1. Correction Factor = Insertion loss + cable loss
2. Margin value = Emission level – Limit value
3. For 802.11g mode, Antenna (2).
4. The EUT can be operated in transmitting, stand-by and receiving mode. After preliminary scan, EUT in transmitting mode has highest emission. The EUT was set in transmitting mode at final test to get the worst case test results.

## 2.7 Photos of Conduction Test

**For Antenna (1) :**



**For Antenna (2) :**



### 3. RADIATED EMISSION TEST

#### 3.1 Test Equipments

The following test equipments are utilized in making the measurements contained in this report.

Manufacturer or Type	Model No	Serial No	Date of Calibration	Calibration Period	Remark
CHASE BI-LOG ANTENNA	CBL6112B	2421	June 15, 2004	1 Year	FINAL
R/S SPECTRUM ANALYZER	FSEK30	835253/002	September 06, 2004	1 Year	FINAL
OPEN SITE	-----	No.2	May 07, 2004	1 Year	FINAL
N TYPE COAXIAL CABLE	CHA9525	4	June 03, 2004	1 Year	FINAL
Horn Antenna	AH-118	10089	April 09, 2005	1 Year	FINAL
HP Pre-amplifier	8449B	3008A01471	November 24, 2004	1 Year	FINAL
HP High pass filter	84300/80038	002	CAL. ON USE	1 Year	FINAL
Horn Antenna	AH-840	3077	February 25, 2005	1 Year	FINAL

#### 3.2 Test Setup

The diagram below shows the test setup that is utilized to make the measurements for emission from 30 to 1GHz.

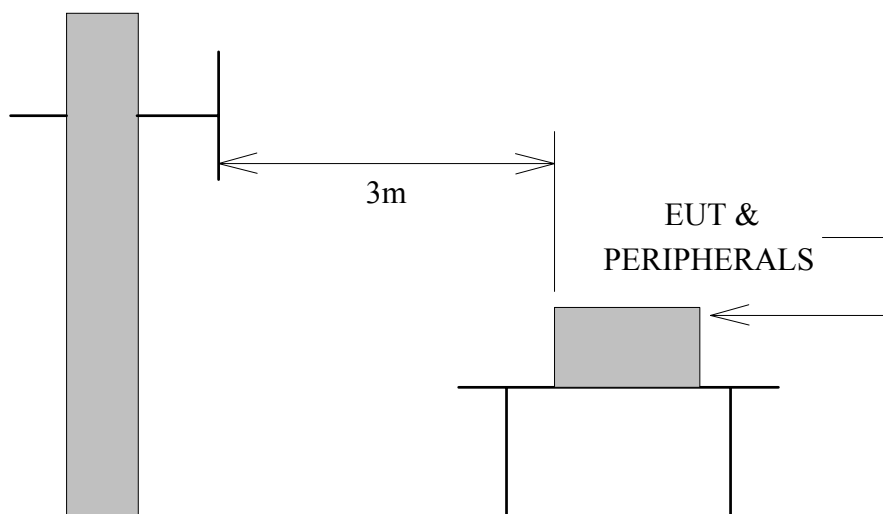

Antenna Elevation Variable

The diagram below shows the test setup that is utilized to make the measurements for emission above 1GHz.

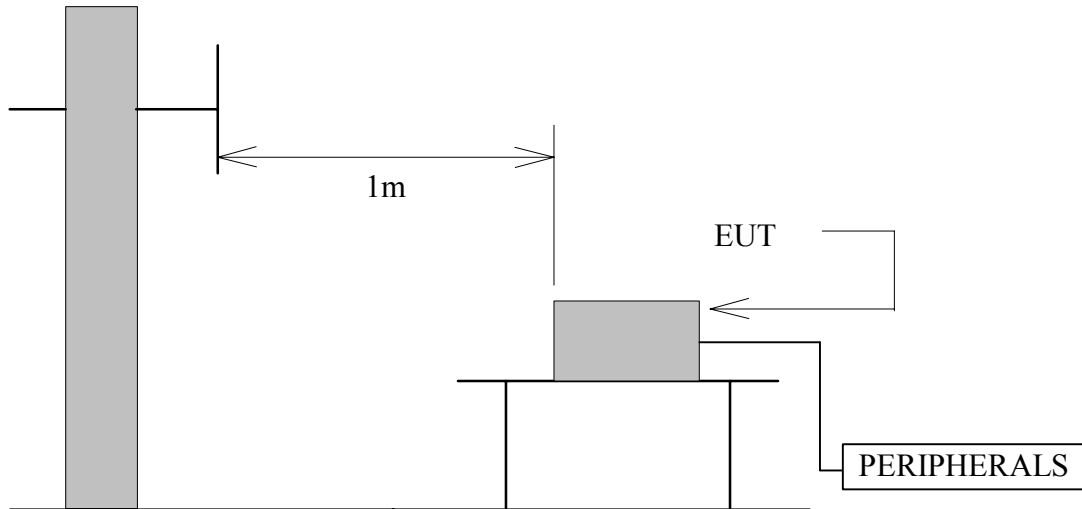

Antenna Elevation Variable

### 3.3 Radiation Limit

For unintentional device, according to § 15.109(a), except for Class A digital devices, the field strength of radiated emissions from unintentional radiators at a distance of 3 meters shall not exceed the following values :

Frequency (MHz)	Distance (Meters)	Radiated (dBμV/M)	Radiated (μV/M)
30-88	3	40.0	100
88-216	3	43.5	150
216-960	3	46.0	200
Above 960	3	54.0	500

For intentional device, according to § 15.209(a), the general requirement of field strength of radiated emissions from intentional radiators at a distance of 3 meters shall not exceed the above table. According to § 15.247(c), in any 100kHz bandwidth outside the frequency band in which the EUT is operating, the radiofrequency power that is produced by the intentional radiator shall be at least 20dB below that in the 100kHz bandwidth within the band that contains the highest level of desired power.



### 3.4 Test Procedures

- a. The EUT was placed on the top of a rotating table 0.8 meters above the ground at a 10 meter open area test site. The table was rotated 360 degrees to determine the position of the highest radiation.
- b. During performing radiated emission below 1GHz, the EUT was set 3 meters away from the interference-receiving antenna, which was mounted on the top of a variable-height antenna tower. During performing radiated emission above 1GHz, the EUT was set 1 meters away from the interference-receiving antenna.
- c. The antenna is a broadband antenna, and its height is varied from one meter to four meters above the ground to determine the maximum value of the field strength. Both horizontal and vertical polarization of the antenna are set to make the measurement.
- d. For each suspected emission, the EUT was arranged to its worst case and then the antenna was tuned to heights from 1 meter to 4 meters and the table was turned from 0 degrees to 360 degrees to find the maximum reading.
- e. The test-receiver system was set to Peak Detect Function and Specified Bandwidth with Maximum Hold Mode.
- f. If the emission level of the EUT in peak mode was 10 dB lower than the limit specified, then testing could be stopped and the peak values of the EUT would be reported. Otherwise the emissions that did not have 10 dB margin would be re-tested one by one using peak, quasi-peak or average method as specified and then reported in a data sheet.

NOTE :

1. The resolution bandwidth and video bandwidth of test receiver/spectrum analyzer is 120 KHz for Peak detection (PK) and Quasi-peak detection (QP) at frequency below 1GHz.
2. The resolution bandwidth and video bandwidth of test receiver/spectrum analyzer is 1 MHz for Peak detection and frequency above 1GHz.
3. The resolution bandwidth of test receiver/spectrum analyzer is 1 MHz and the video bandwidth is 10 Hz for Average detection (AV) at frequency above 1GHz.

### 3.5 Uncertainty of Radiated Emission

The uncertainty of radiated emission is  $\pm 3.2$ dB.



### 3.6 Radiated RF Noise Measurement

The frequency spectrum from 30 MHz to 1000 MHz was investigated. All emissions not reported are much lower than the prescribed limits.

All readings are quasi-peak values.

<b>Company</b>	Z-Com, Inc.	<b>Test Date</b>	2004/09/01
<b>Product Name</b>	IEEE 802.11 b/g WLAN MiniPCI Card	<b>Test By</b>	Vincent Chen
<b>Model Name</b>	XG-602MB	<b>TEMP &amp; Humidity</b>	30°C, 55%

Frequency (MHz)	Antenna Factor (dB/m)	Cable Loss (dB)	Meter Reading at 3m(dBμV)		Limits (dBμV/m)	Emission Level at 3m(dBμV/m)	
			Horizontal	Vertical		Horizontal	Vertical
30.00	17.01	0.97	*	*	40.00	*	*
66.86	8.42	1.53	17.50	16.50	40.00	27.45	26.45
199.99	9.80	3.14	23.50	13.50	43.50	36.44	26.44
239.98	12.13	3.84	21.30	15.70	46.00	37.27	31.67
279.99	13.19	4.18	23.00	13.00	46.00	40.38	30.38
319.97	14.49	4.41	17.10	9.90	46.00	36.00	28.80
359.99	16.45	4.63	20.20	10.40	46.00	41.28	31.48
399.98	18.41	4.85	15.20	13.40	46.00	38.46	36.66
439.99	18.18	4.99	5.50	5.50	46.00	28.66	28.66
479.99	17.95	5.12	4.40	10.60	46.00	27.47	33.67
1000.00	21.84	7.66	*	*	54.00	*	*

REMARKS :

- \* Undetectable
- Emission level (dBμV/m) = Antenna Factor (dB/m) + Cable loss (dB) + Meter Reading (dBμV).
- The EUT can be operated in transmitting, stand-by and receiving mode. After preliminary scan, EUT in transmitting mode has highest emission. The EUT was set in transmitting mode at final test to get the worst case test results.
- According to technical experiences, all spurious emission at channel 1,6,11 are almost the same below 1GHz,so that the channel 1 was chosen as representative in final test.
- Antenna (1).





The frequency spectrum from 30 MHz to 1000 MHz was investigated. All emissions not reported are much lower than the prescribed limits.  
All readings are quasi-peak values.

<b>Company</b>	Z-Com, Inc.	<b>Test Date</b>	2004/05/05
<b>Product Name</b>	IEEE 802.11 b/g WLAN MiniPCI Card	<b>Test By</b>	Vincent Chen
<b>Model Name</b>	XG-602MB	<b>TEMP &amp; Humidity</b>	27.2°C, 64%

Frequency (MHz)	Antenna Factor (dB/m)	Cable Loss (dB)	Meter Reading at 3m(dBμV)		Limits (dBμV/m)	Emission Level at 3m(dBμV/m)	
			Horizontal	Vertical		Horizontal	Vertical
30.00	21.39	0.90	*	*	40.00	*	*
66.00	7.03	1.46	17.84	17.30	40.00	26.33	25.79
199.99	10.39	2.80	24.10	14.20	43.50	37.29	27.39
239.98	12.55	3.12	25.60	16.60	46.00	41.27	32.27
279.99	13.34	3.44	24.20	16.40	46.00	40.98	33.18
319.97	14.25	3.72	18.30	12.10	46.00	36.27	30.07
359.99	15.74	3.96	21.50	13.50	46.00	41.20	33.20
399.98	17.24	4.20	16.40	14.50	46.00	37.84	35.94
439.99	17.67	4.48	6.10	6.80	46.00	28.25	28.95
479.99	18.10	4.76	4.80	8.90	46.00	27.66	31.76
1000.00	21.58	7.00	*	*	54.00	*	*

## REMARKS :

- \* Undetectable
- Emission level (dBμV/m) = Antenna Factor (dB/m) + Cable loss (dB) + Meter Reading (dBμV).
- The EUT can be operated in transmitting, stand-by and receiving mode. After preliminary scan, EUT in transmitting mode has highest emission. The EUT was set in transmitting mode at final test to get the worst case test results.
- According to technical experiences, all spurious emission at channel 1,6,11 are almost the same below 1GHz,so that the channel 1 was chosen as representative in final test.
- For Antenna (2).



The frequency spectrum above 1 GHz was investigated. All emissions not reported are much lower than the prescribed limits. Readings are both peak and average values.

Company	Z-Com, Inc.	Test Date	2004/08/20
Product Name	IEEE 802.11 b/g WLAN MiniPCI Card	Test By	Vincent Chen
Model Name	XG-602MB	TEMP & Humidity	31.6°C , 53%

CH1 RX				Measurement Distance at 1m Horizontal polarity							
Freq. (MHz)	Reading (dBμV)	AF (dBμV)	Cable (dB)	Pre-amp (dB)	Dist (dB)	Filter (dB)	Level (dBμV/m)	Limit (dBμV/m)	Margin (dB)	Mark (P/Q/A)	Height (Meter)
4824.12	46.28	34.44	5.08	35.16	9.50	0.00	41.14	74	-32.86	P	1.0
4824.12	37.71	34.44	5.08	35.16	9.50	0.00	32.57	54	-21.43	A	1.0
7236.00	44.78	39.81	6.74	35.65	9.50	0.00	46.17	74	-27.83	P	1.0
7236.00	33.02	39.81	6.74	35.65	9.50	0.00	34.41	54	-19.59	A	1.0
9647.71	48.41	38.54	8.29	36.44	9.50	0.00	49.30	74	-24.70	P	1.0
9647.71	41.14	38.54	8.29	36.44	9.50	0.00	42.03	54	-11.97	A	1.0

1. AF: Antenna Factor, Cable: Cable Loss, Pre-Amp: Preamplifier gain.
2. Spectrum analyzer setting P(Peak): RBW=1MHz, VBW=1MHz, A(Average): RBW=1MHz, VBW=10Hz
3. Dist : correction to extra plate reading to 3m specification distance 1m measurement distance = -9.5dB
4. The result basic equation calculation as follow :  

$$\text{Level} = \text{Reading} + \text{AF} + \text{Cable} - \text{Preamp} + \text{Filter} - \text{Dist}, \text{Margin} = \text{Level} - \text{Limit}$$
5. The test limit is 3M limit.
6. The frequency was searched to 18GHz.
7. The other emission levels were very low against the limit.
8. For Antenna (1).



The frequency spectrum above 1 GHz was investigated. All emissions not reported are much lower than the prescribed limits. Readings are both peak and average values.

Company	Z-Com, Inc.	Test Date	2004/08/20
Product Name	IEEE 802.11 b/g WLAN MiniPCI Card	Test By	Vincent Chen
Model Name	XG-602MB	TEMP & Humidity	31.6°C , 53%

CH1 RX				Measurement Distance at 1m Vertical polarity							
Freq. (MHz)	Reading (dBμV)	AF (dBμV)	Cable (dB)	Pre-amp (dB)	Dist (dB)	Filter (dB)	Level (dBμV/m)	Limit (dBμV/m)	Margin (dB)	Mark (P/Q/A)	Height (Meter)
4824.09	48.79	34.44	5.08	35.16	9.50	0.00	43.65	74	-30.35	P	1.0
4824.09	45.52	34.44	5.08	35.16	9.50	0.00	40.38	54	-13.62	A	1.0
7236.06	45.15	39.81	6.74	35.65	9.50	0.00	46.54	74	-27.46	P	1.0
7236.06	33.12	39.81	6.74	35.65	9.50	0.00	34.51	54	-19.49	A	1.0
9647.85	50.87	38.54	8.29	36.44	9.50	0.00	51.76	74	-22.24	P	1.0
9647.85	45.89	38.54	8.29	36.44	9.50	0.00	46.78	54	-7.22	A	1.0

1. AF: Antenna Factor, Cable: Cable Loss, Pre-Amp: Preamplifier gain.
2. Spectrum analyzer setting P(Peak): RBW=1MHz, VBW=1MHz, A(Average): RBW=1MHz, VBW=10Hz
3. Dist : correction to extra plate reading to 3m specification distance 1m measurement distance = -9.5dB
4. The result basic equation calculation as follow :  

$$\text{Level} = \text{Reading} + \text{AF} + \text{Cable} - \text{Preamp} + \text{Filter} - \text{Dist}, \text{Margin} = \text{Level} - \text{Limit}$$
5. The test limit is 3M limit.
6. The frequency was searched to 18GHz.
7. The other emission levels were very low against the limit.
8. For Antenna (1).



The frequency spectrum above 1 GHz was investigated. All emissions not reported are much lower than the prescribed limits. Readings are both peak and average values.

Company	Z-Com, Inc.	Test Date	2004/08/20
Product Name	IEEE 802.11 b/g WLAN MiniPCI Card	Test By	Vincent Chen
Model Name	XG-602MB	TEMP & Humidity	31.6°C , 53%

CH6 RX				Measurement Distance at 1m Horizontal polarity							
Freq. (MHz)	Reading (dBμV)	AF (dBμV)	Cable (dB)	Pre-amp (dB)	Dist (dB)	Filter (dB)	Level (dBμV/m)	Limit (dBμV/m)	Margin (dB)	Mark (P/Q/A)	Height (Meter)
4873.88	46.59	34.77	5.10	35.20	9.50	0.00	41.76	74	-32.24	P	1.0
4873.88	39.11	34.77	5.10	35.20	9.50	0.00	34.28	54	-19.72	A	1.0
7311.00	45.23	39.78	6.79	35.64	9.50	0.00	46.66	74	-27.34	P	1.0
7311.00	33.05	39.78	6.79	35.64	9.50	0.00	34.48	54	-19.52	A	1.0
9747.78	45.94	38.53	8.33	36.60	9.50	0.00	46.70	74	-27.30	P	1.0
9747.78	36.72	38.53	8.33	36.60	9.50	0.00	37.48	54	-16.52	A	1.0

1. AF: Antenna Factor, Cable: Cable Loss, Pre-Amp: Preamplifier gain.
2. Spectrum analyzer setting P(Peak): RBW=1MHz, VBW=1MHz, A(Average): RBW=1MHz, VBW=10Hz
3. Dist : correction to extra plate reading to 3m specification distance 1m measurement distance = -9.5dB
4. The result basic equation calculation as follow :  

$$\text{Level} = \text{Reading} + \text{AF} + \text{Cable} - \text{Preamp} + \text{Filter} - \text{Dist}, \text{Margin} = \text{Level} - \text{Limit}$$
5. The test limit is 3M limit.
6. The frequency was searched to 18GHz.
7. The other emission levels were very low against the limit.
8. For Antenna (1).



The frequency spectrum above 1 GHz was investigated. All emissions not reported are much lower than the prescribed limits. Readings are both peak and average values.

Company	Z-Com, Inc.	Test Date	2004/08/20
Product Name	IEEE 802.11 b/g WLAN MiniPCI Card	Test By	Vincent Chen
Model Name	XG-602MB	TEMP & Humidity	31.6°C , 53%

CH6 RX				Measurement Distance at 1m Vertical polarity							
Freq. (MHz)	Reading (dBμV)	AF (dBμV)	Cable (dB)	Pre-amp (dB)	Dist (dB)	Filter (dB)	Level (dBμV/m)	Limit (dBμV/m)	Margin (dB)	Mark (P/Q/A)	Height (Meter)
4874.03	49.05	34.77	5.10	35.20	9.50	0.00	44.22	74	-29.78	P	1.0
4874.03	43.81	34.77	5.10	35.20	9.50	0.00	38.98	54	-15.02	A	1.0
7311.08	46.18	39.78	6.79	35.64	9.50	0.00	47.61	74	-26.39	P	1.0
7311.08	33.32	39.78	6.79	35.64	9.50	0.00	34.75	54	-19.25	A	1.0
9747.80	49.16	38.53	8.33	36.60	9.50	0.00	49.92	74	-24.08	P	1.0
9747.80	42.19	38.53	8.33	36.60	9.50	0.00	42.95	54	-11.05	A	1.0

1. AF: Antenna Factor, Cable: Cable Loss, Pre-Amp: Preamplifier gain.
2. Spectrum analyzer setting P(Peak): RBW=1MHz, VBW=1MHz, A(Average): RBW=1MHz, VBW=10Hz
3. Dist : correction to extra plate reading to 3m specification distance 1m measurement distance = -9.5dB
4. The result basic equation calculation as follow :  

$$\text{Level} = \text{Reading} + \text{AF} + \text{Cable} - \text{Preamp} + \text{Filter} - \text{Dist}, \text{Margin} = \text{Level} - \text{Limit}$$
5. The test limit is 3M limit.
6. The frequency was searched to 18GHz.
7. The other emission levels were very low against the limit.
8. For Antenna (1).



The frequency spectrum above 1 GHz was investigated. All emissions not reported are much lower than the prescribed limits. Readings are both peak and average values.

Company	Z-Com, Inc.	Test Date	2004/08/20
Product Name	IEEE 802.11 b/g WLAN MiniPCI Card	Test By	Vincent Chen
Model Name	XG-602MB	TEMP & Humidity	31.6°C , 53%

CH11 RX				Measurement Distance at 1m Horizontal polarity							
Freq. (MHz)	Reading (dBμV)	AF (dBμV)	Cable (dB)	Pre-amp (dB)	Dist (dB)	Filter (dB)	Level (dBμV/m)	Limit (dBμV/m)	Margin (dB)	Mark (P/Q/A)	Height (Meter)
4923.87	46.83	35.10	5.12	35.24	9.50	0.00	42.30	74	-31.70	P	1.0
4923.87	39.37	35.10	5.12	35.24	9.50	0.00	34.84	54	-19.16	A	1.0
7385.99	44.65	39.75	6.84	35.62	9.50	0.00	46.12	74	-27.88	P	1.0
7385.99	33.18	39.75	6.84	35.62	9.50	0.00	34.65	54	-19.35	A	1.0
9847.89	46.94	38.52	8.37	36.76	9.50	0.00	47.56	74	-26.44	P	1.0
9847.89	38.37	38.52	8.37	36.76	9.50	0.00	38.99	54	-15.01	A	1.0

1. AF: Antenna Factor, Cable: Cable Loss, Pre-Amp: Preamplifier gain.
2. Spectrum analyzer setting P(Peak): RBW=1MHz, VBW=1MHz, A(Average): RBW=1MHz, VBW=10Hz
3. Dist : correction to extra plate reading to 3m specification distance 1m measurement distance = -9.5dB
4. The result basic equation calculation as follow :  

$$\text{Level} = \text{Reading} + \text{AF} + \text{Cable} - \text{Preamp} + \text{Filter} - \text{Dist}, \text{Margin} = \text{Level} - \text{Limit}$$
5. The test limit is 3M limit.
6. The frequency was searched to 18GHz.
7. The other emission levels were very low against the limit.
8. For Antenna (1).



The frequency spectrum above 1 GHz was investigated. All emissions not reported are much lower than the prescribed limits. Readings are both peak and average values.

Company	Z-Com, Inc.	Test Date	2004/08/20
Product Name	IEEE 802.11 b/g WLAN MiniPCI Card	Test By	Vincent Chen
Model Name	XG-602MB	TEMP & Humidity	31.6°C , 53%

CH11 RX				Measurement Distance at 1m Vertical polarity							
Freq. (MHz)	Reading (dBμV)	AF (dBμV)	Cable (dB)	Pre-amp (dB)	Dist (dB)	Filter (dB)	Level (dBμV/m)	Limit (dBμV/m)	Margin (dB)	Mark (P/Q/A)	Height (Meter)
4924.00	47.68	35.10	5.12	35.24	9.50	0.00	43.15	74	-30.85	P	1.0
4924.00	41.66	35.10	5.12	35.24	9.50	0.00	37.13	54	-16.87	A	1.0
7386.07	45.57	39.75	6.84	35.62	9.50	0.00	47.04	74	-26.96	P	1.0
7386.07	33.32	39.75	6.84	35.62	9.50	0.00	34.79	54	-19.21	A	1.0
9848.00	48.47	38.52	8.37	36.76	9.50	0.00	49.09	74	-24.91	P	1.0
9848.00	40.57	38.52	8.37	36.76	9.50	0.00	41.19	54	-12.81	A	1.0

1. AF: Antenna Factor, Cable: Cable Loss, Pre-Amp: Preamplifier gain.
2. Spectrum analyzer setting P(Peak): RBW=1MHz, VBW=1MHz, A(Average): RBW=1MHz, VBW=10Hz
3. Dist : correction to extra plate reading to 3m specification distance 1m measurement distance = -9.5dB
4. The result basic equation calculation as follow :  

$$\text{Level} = \text{Reading} + \text{AF} + \text{Cable} - \text{Preamp} + \text{Filter} - \text{Dist}, \text{Margin} = \text{Level} - \text{Limit}$$
5. The test limit is 3M limit.
6. The frequency was searched to 18GHz.
7. The other emission levels were very low against the limit.
8. For Antenna (1).



The frequency spectrum above 1 GHz was investigated. All emissions not reported are much lower than the prescribed limits. Readings are both peak and average values.

Company	Z-Com, Inc.	Test Date	2005/04/29
Product Name	IEEE 802.11 b/g WLAN MiniPCI Card	Test By	Vincent Chen
Model Name	XG-602MB	TEMP & Humidity	32.5°C , 56%

CH1 RX				Measurement Distance at 1m Horizontal polarity							
Freq. (MHz)	Reading (dBμV)	AF (dBμV)	Cable (dB)	Pre-amp (dB)	Dist (dB)	Filter (dB)	Level (dBμV/m)	Limit (dBμV/m)	Margin (dB)	Mark (P/Q/A)	Height (Meter)
4824.12	48.19	34.44	5.08	35.16	9.50	0.00	43.05	74	-30.95	P	1.0
4824.12	38.94	34.44	5.08	35.16	9.50	0.00	33.80	54	-20.20	A	1.0
7236.00	44.95	39.81	6.74	35.65	9.50	0.00	46.34	74	-27.66	P	1.0
7236.00	34.30	39.81	6.74	35.65	9.50	0.00	35.69	54	-18.31	A	1.0
9647.71	49.36	38.54	8.29	36.44	9.50	0.00	50.25	74	-23.75	P	1.0
9647.71	43.09	38.54	8.29	36.44	9.50	0.00	43.98	54	-10.02	A	1.0

1. AF: Antenna Factor, Cable: Cable Loss, Pre-Amp: Preamplifier gain.
2. Spectrum analyzer setting P(Peak): RBW=1MHz, VBW=1MHz, A(Average): RBW=1MHz, VBW=10Hz
3. Dist : correction to extra plate reading to 3m specification distance 1m measurement distance = -9.5dB
4. The result basic equation calculation as follow :  

$$\text{Level} = \text{Reading} + \text{AF} + \text{Cable} - \text{Preamp} + \text{Filter} - \text{Dist}, \text{Margin} = \text{Level} - \text{Limit}$$
5. The test limit is 3M limit.
6. The frequency was searched to 18GHz.
7. The other emission levels were very low against the limit.
8. For Antenna (2).





The frequency spectrum above 1 GHz was investigated. All emissions not reported are much lower than the prescribed limits. Readings are both peak and average values.

Company	Z-Com, Inc.	Test Date	2005/04/29
Product Name	IEEE 802.11 b/g WLAN MiniPCI Card	Test By	Vincent Chen
Model Name	XG-602MB	TEMP & Humidity	32.5°C , 56%

CH1 RX				Measurement Distance at 1m Vertical polarity							
Freq. (MHz)	Reading (dBμV)	AF (dBμV)	Cable (dB)	Pre-amp (dB)	Dist (dB)	Filter (dB)	Level (dBμV/m)	Limit (dBμV/m)	Margin (dB)	Mark (P/Q/A)	Height (Meter)
4824.09	48.79	34.44	5.08	35.16	9.50	0.00	43.65	74	-30.35	P	1.0
4824.09	45.52	34.44	5.08	35.16	9.50	0.00	40.38	54	-13.62	A	1.0
7236.06	45.15	39.81	6.74	35.65	9.50	0.00	46.54	74	-27.46	P	1.0
7236.06	33.12	39.81	6.74	35.65	9.50	0.00	34.51	54	-19.49	A	1.0
9647.85	50.87	38.54	8.29	36.44	9.50	0.00	51.76	74	-22.24	P	1.0
9647.85	45.89	38.54	8.29	36.44	9.50	0.00	46.78	54	-7.22	A	1.0

1. AF: Antenna Factor, Cable: Cable Loss, Pre-Amp: Preamplifier gain.
2. Spectrum analyzer setting P(Peak): RBW=1MHz, VBW=1MHz, A(Average): RBW=1MHz, VBW=10Hz
3. Dist : correction to extra plate reading to 3m specification distance 1m measurement distance = -9.5dB
4. The result basic equation calculation as follow :  

$$\text{Level} = \text{Reading} + \text{AF} + \text{Cable} - \text{Preamp} + \text{Filter} - \text{Dist}, \text{Margin} = \text{Level} - \text{Limit}$$
5. The test limit is 3M limit.
6. The frequency was searched to 18GHz.
7. The other emission levels were very low against the limit.
8. For Antenna (2).



The frequency spectrum above 1 GHz was investigated. All emissions not reported are much lower than the prescribed limits. Readings are both peak and average values.

Company	Z-Com, Inc.	Test Date	2005/04/29
Product Name	IEEE 802.11 b/g WLAN MiniPCI Card	Test By	Vincent Chen
Model Name	XG-602MB	TEMP & Humidity	32.5°C , 56%

CH6 RX				Measurement Distance at 1m Horizontal polarity							
Freq. (MHz)	Reading (dBμV)	AF (dBμV)	Cable (dB)	Pre-amp (dB)	Dist (dB)	Filter (dB)	Level (dBμV/m)	Limit (dBμV/m)	Margin (dB)	Mark (P/Q/A)	Height (Meter)
4873.88	47.44	34.77	5.10	35.20	9.50	0.00	42.61	74	-31.39	P	1.0
4873.88	40.05	34.77	5.10	35.20	9.50	0.00	35.22	54	-18.78	A	1.0
7311.00	45.62	39.78	6.79	35.64	9.50	0.00	47.05	74	-26.95	P	1.0
7311.00	34.20	39.78	6.79	35.64	9.50	0.00	35.63	54	-18.37	A	1.0
9747.78	48.56	38.53	8.33	36.60	9.50	0.00	49.32	74	-24.68	P	1.0
9747.78	42.18	38.53	8.33	36.60	9.50	0.00	42.94	54	-11.06	A	1.0

1. AF: Antenna Factor, Cable: Cable Loss, Pre-Amp: Preamplifier gain.
2. Spectrum analyzer setting P(Peak): RBW=1MHz, VBW=1MHz, A(Average): RBW=1MHz, VBW=10Hz
3. Dist : correction to extra plate reading to 3m specification distance 1m measurement distance = -9.5dB
4. The result basic equation calculation as follow :  

$$\text{Level} = \text{Reading} + \text{AF} + \text{Cable} - \text{Preamp} + \text{Filter} - \text{Dist}, \text{Margin} = \text{Level} - \text{Limit}$$
5. The test limit is 3M limit.
6. The frequency was searched to 18GHz.
7. The other emission levels were very low against the limit.
8. For Antenna (2).



The frequency spectrum above 1 GHz was investigated. All emissions not reported are much lower than the prescribed limits. Readings are both peak and average values.

Company	Z-Com, Inc.	Test Date	2005/04/29
Product Name	IEEE 802.11 b/g WLAN MiniPCI Card	Test By	Vincent Chen
Model Name	XG-602MB	TEMP & Humidity	32.5°C , 56%

CH6 RX				Measurement Distance at 1m Vertical polarity							
Freq. (MHz)	Reading (dBμV)	AF (dBμV)	Cable (dB)	Pre-amp (dB)	Dist (dB)	Filter (dB)	Level (dBμV/m)	Limit (dBμV/m)	Margin (dB)	Mark (P/Q/A)	Height (Meter)
4874.03	49.05	34.77	5.10	35.20	9.50	0.00	44.22	74	-29.78	P	1.0
4874.03	43.81	34.77	5.10	35.20	9.50	0.00	38.98	54	-15.02	A	1.0
7311.08	46.18	39.78	6.79	35.64	9.50	0.00	47.61	74	-26.39	P	1.0
7311.08	33.32	39.78	6.79	35.64	9.50	0.00	34.75	54	-19.25	A	1.0
9747.80	49.16	38.53	8.33	36.60	9.50	0.00	49.92	74	-24.08	P	1.0
9747.80	42.19	38.53	8.33	36.60	9.50	0.00	42.95	54	-11.05	A	1.0

1. AF: Antenna Factor, Cable: Cable Loss, Pre-Amp: Preamplifier gain.
2. Spectrum analyzer setting P(Peak): RBW=1MHz, VBW=1MHz, A(Average): RBW=1MHz, VBW=10Hz
3. Dist : correction to extra plate reading to 3m specification distance 1m measurement distance = -9.5dB
4. The result basic equation calculation as follow :  

$$\text{Level} = \text{Reading} + \text{AF} + \text{Cable} - \text{Preamp} + \text{Filter} - \text{Dist}, \text{Margin} = \text{Level} - \text{Limit}$$
5. The test limit is 3M limit.
6. The frequency was searched to 18GHz.
7. The other emission levels were very low against the limit.
8. For Antenna (2).



The frequency spectrum above 1 GHz was investigated. All emissions not reported are much lower than the prescribed limits. Readings are both peak and average values.

Company	Z-Com, Inc.	Test Date	2005/04/29
Product Name	IEEE 802.11 b/g WLAN MiniPCI Card	Test By	Vincent Chen
Model Name	XG-602MB	TEMP & Humidity	32.5°C , 56%

CH11 RX				Measurement Distance at 1m Horizontal polarity							
Freq. (MHz)	Reading (dBμV)	AF (dBμV)	Cable (dB)	Pre-amp (dB)	Dist (dB)	Filter (dB)	Level (dBμV/m)	Limit (dBμV/m)	Margin (dB)	Mark (P/Q/A)	Height (Meter)
4923.87	47.58	35.10	5.12	35.24	9.50	0.00	43.05	74	-30.95	P	1.0
4923.87	41.17	35.10	5.12	35.24	9.50	0.00	36.64	54	-17.36	A	1.0
7385.99	45.62	39.75	6.84	35.62	9.50	0.00	47.09	74	-26.91	P	1.0
7385.99	34.10	39.75	6.84	35.62	9.50	0.00	35.57	54	-18.43	A	1.0
9847.89	48.14	38.52	8.37	36.76	9.50	0.00	48.76	74	-25.24	P	1.0
9847.89	41.35	38.52	8.37	36.76	9.50	0.00	41.97	54	-12.03	A	1.0

1. AF: Antenna Factor, Cable: Cable Loss, Pre-Amp: Preamplifier gain.
2. Spectrum analyzer setting P(Peak): RBW=1MHz, VBW=1MHz, A(Average): RBW=1MHz, VBW=10Hz
3. Dist : correction to extra plate reading to 3m specification distance 1m measurement distance = -9.5dB
4. The result basic equation calculation as follow :  

$$\text{Level} = \text{Reading} + \text{AF} + \text{Cable} - \text{Preamp} + \text{Filter} - \text{Dist}, \text{Margin} = \text{Level} - \text{Limit}$$
5. The test limit is 3M limit.
6. The frequency was searched to 18GHz.
7. The other emission levels were very low against the limit.
8. For Antenna (2).



The frequency spectrum above 1 GHz was investigated. All emissions not reported are much lower than the prescribed limits. Readings are both peak and average values.

Company	Z-Com, Inc.	Test Date	2005/04/29
Product Name	IEEE 802.11 b/g WLAN MiniPCI Card	Test By	Vincent Chen
Model Name	XG-602MB	TEMP & Humidity	32.5°C , 56%

CH11 RX				Measurement Distance at 1m Vertical polarity							
Freq. (MHz)	Reading (dBμV)	AF (dBμV)	Cable (dB)	Pre-amp (dB)	Dist (dB)	Filter (dB)	Level (dBμV/m)	Limit (dBμV/m)	Margin (dB)	Mark (P/Q/A)	Height (Meter)
4924.00	50.28	35.10	5.12	35.24	9.50	0.00	45.75	74	-28.25	P	1.0
4924.00	41.59	35.10	5.12	35.24	9.50	0.00	37.06	54	-16.94	A	1.0
7386.07	45.63	39.75	6.84	35.62	9.50	0.00	47.10	74	-26.90	P	1.0
7386.07	33.80	39.75	6.84	35.62	9.50	0.00	35.27	54	-18.73	A	1.0
9848.00	50.16	38.52	8.37	36.76	9.50	0.00	50.78	74	-23.22	P	1.0
9848.00	43.58	38.52	8.37	36.76	9.50	0.00	44.20	54	-9.80	A	1.0

1. AF: Antenna Factor, Cable: Cable Loss, Pre-Amp: Preamplifier gain.
2. Spectrum analyzer setting P(Peak): RBW=1MHz, VBW=1MHz, A(Average): RBW=1MHz, VBW=10Hz
3. Dist : correction to extra plate reading to 3m specification distance 1m measurement distance = -9.5dB
4. The result basic equation calculation as follow :  

$$\text{Level} = \text{Reading} + \text{AF} + \text{Cable} - \text{Preamp} + \text{Filter} - \text{Dist}, \text{Margin} = \text{Level} - \text{Limit}$$
5. The test limit is 3M limit.
6. The frequency was searched to 18GHz.
7. The other emission levels were very low against the limit.
8. For Antenna (2).



The frequency spectrum above 1 GHz was investigated. All emissions not reported are much lower than the prescribed limits. Readings are both peak and average values.

Company	Z-Com, Inc.	Test Date	2004/08/18
Product Name	IEEE 802.11 b/g WLAN MiniPCI Card	Test By	Vincent Chen
Model Name	XG-602MB	TEMP & Humidity	25.9°C , 65%

CH1 TX				Measurement Distance at 1m Horizontal polarity							
Freq. (MHz)	Reading (dBμV)	AF (dBμV)	Cable (dB)	Pre-amp (dB)	Dist (dB)	Filter (dB)	Level (dBμV/m)	Limit (dBμV/m)	Margin (dB)	Mark (P/Q/A)	Height (Meter)
* 2389.90	21.00	31.81	3.57	0.00	9.50	0.00	46.88	74	-27.12	P	1.00
* 2389.90	8.40	31.81	3.57	0.00	9.50	0.00	34.28	54	-19.72	A	1.00
2413.35	80.02	31.79	3.58	0.00	9.50	0.00	105.89	Fundamental Frequency		P	1.00
2413.35	73.39	31.79	3.58	0.00	9.50	0.00	99.26			A	1.00
* 4823.92	47.14	34.44	5.08	35.16	9.50	2.00	44.01	74	-29.99	P	1.00
* 4823.92	39.47	34.44	5.08	35.16	9.50	2.00	36.34	54	-17.66	A	1.00
7236.00	45.31	39.81	6.74	35.65	9.50	2.00	48.70	74	-25.30	P	1.00
7236.00	34.27	39.81	6.74	35.65	9.50	2.00	37.66	54	-16.34	A	1.00
9647.85	48.26	38.54	8.29	36.44	9.50	0.61	49.76	74	-24.24	P	1.00
9647.85	40.53	38.54	8.29	36.44	9.50	0.61	42.03	54	-11.97	A	1.00
* 12066.75	-----	-----	-----	-----	9.50	0.80	-----	-----	-----	-----	1.00
* 14480.10	-----	-----	-----	-----	9.50	0.68	-----	-----	-----	-----	1.00
16893.45	-----	-----	-----	-----	9.50	0.44	-----	-----	-----	-----	1.00
* 19306.80	-----	-----	-----	-----	9.50	1.97	-----	-----	-----	-----	1.00
21720.15	-----	-----	-----	-----	9.50	0.81	-----	-----	-----	-----	1.00
24133.50	-----	-----	-----	-----	9.50	2.89	-----	-----	-----	-----	1.00

Note :

- The measurement was searched to 10th harmonic, Remark “---” means that the emissions level is too low to be measured.
- AF: Antenna Factor, Cable: Cable Loss, Pre-Amp: Preamplifier gain, Filter: High Pass Filter Insertion Loss (3.5GHz)
- Spectrum analyzer setting P(Peak): RBW=1MHz, VBW=1MHz, A(Average): RBW=1MHz, VBW=10Hz
- Remark “\*” means the Restricted band.
- Dist : correction to extra plate reading to 3m specification distance 1m measurement distance = -9.5dB
- The result basic equation calculation is as follow:  
 $Level = Reading + AF + Cable - Preamp + Filter - Dist$ ,  $Margin = Level - Limit$
- The other emission levels were very low against the limit
- The test limit distance is 3M limit.
- For 802.11b mode at 11Mbps, Antenna (1).



The frequency spectrum above 1 GHz was investigated. All emissions not reported are much lower than the prescribed limits. Readings are both peak and average values.

Company	Z-Com, Inc.	Test Date	2004/08/18
Product Name	IEEE 802.11 b/g WLAN MiniPCI Card	Test By	Vincent Chen
Model Name	XG-602MB	TEMP & Humidity	25.9°C , 65%

CH1 TX				Measurement Distance at 1m Vertical polarity							
Freq. (MHz)	Reading (dBμV)	AF (dBμV)	Cable (dB)	Pre-amp (dB)	Dist (dB)	Filter (dB)	Level (dBμV/m)	Limit (dBμV/m)	Margin (dB)	Mark (P/Q/A)	Height (Meter)
* 2389.90	25.20	31.81	3.57	0.00	9.50	0.00	51.08	74	-22.92	P	1.00
* 2389.90	12.40	31.81	3.57	0.00	9.50	0.00	38.28	54	-15.72	A	1.00
2413.25	83.85	31.79	3.58	0.00	9.50	0.00	109.72	Fundamental Frequency		P	1.00
2413.25	76.98	31.79	3.58	0.00	9.50	0.00	102.85			A	1.00
* 4824.00	48.67	34.44	5.08	35.16	9.50	2.00	45.54	74	-28.46	P	1.00
* 4824.00	43.12	34.44	5.08	35.16	9.50	2.00	39.99	54	-14.01	A	1.00
7234.69	45.94	39.81	6.74	35.65	9.50	2.00	49.33	74	-24.67	P	1.00
7234.69	35.42	39.81	6.74	35.65	9.50	2.00	38.81	54	-15.19	A	1.00
9647.86	49.72	38.54	8.29	36.44	9.50	0.61	51.22	74	-22.78	P	1.00
9647.86	43.62	38.54	8.29	36.44	9.50	0.61	45.12	54	-8.88	A	1.00
* 12066.25	-----	-----	-----	-----	9.50	0.80	-----	-----	-----	-----	1.00
* 14479.50	-----	-----	-----	-----	9.50	0.68	-----	-----	-----	-----	1.00
16892.75	-----	-----	-----	-----	9.50	0.44	-----	-----	-----	-----	1.00
* 19306.00	-----	-----	-----	-----	9.50	1.97	-----	-----	-----	-----	1.00
21719.25	-----	-----	-----	-----	9.50	0.81	-----	-----	-----	-----	1.00
24132.50	-----	-----	-----	-----	9.50	2.89	-----	-----	-----	-----	1.00

Note :

- The measurement was searched to 10th harmonic, Remark “---” means that the emissions level is too low to be measured.
- AF: Antenna Factor, Cable: Cable Loss, Pre-Amp: Preamplifier gain, Filter: High Pass Filter Insertion Loss (3.5GHz)
- Spectrum analyzer setting P(Peak): RBW=1MHz, VBW=1MHz, A(Average): RBW=1MHz, VBW=10Hz
- Remark “\*” means the Restricted band.
- Dist : correction to extra plate reading to 3m specification distance 1m measurement distance = -9.5dB
- The result basic equation calculation is as follow:  
 $Level = Reading + AF + Cable - Preamp + Filter - Dist$ ,  $Margin = Level - Limit$
- The other emission levels were very low against the limit
- The test limit distance is 3M limit.
- For 802.11b mode at 11Mbps, Antenna (1).



The frequency spectrum above 1 GHz was investigated. All emissions not reported are much lower than the prescribed limits. Readings are both peak and average values.

Company	Z-Com, Inc.	Test Date	2004/08/18
Product Name	IEEE 802.11 b/g WLAN MiniPCI Card	Test By	Vincent Chen
Model Name	XG-602MB	TEMP & Humidity	25.9°C , 65%

CH6 TX				Measurement Distance at 1m Horizontal polarity							
Freq. (MHz)	Reading (dBμV)	AF (dBμV)	Cable (dB)	Pre-amp (dB)	Dist (dB)	Filter (dB)	Level (dBμV/m)	Limit (dBμV/m)	Margin (dB)	Mark (P/Q/A)	Height (Meter)
2438.35	78.90	31.76	3.59	0.00	9.50	0.00	104.75	Fundamental Frequency		P	1.00
2438.35	72.08	31.76	3.59	0.00	9.50	0.00	97.93			A	1.00
* 4873.77	48.43	34.77	5.10	35.20	9.50	1.80	45.40	74	-28.60	P	1.00
* 4873.77	40.35	34.77	5.10	35.20	9.50	1.80	37.32	54	-16.68	A	1.00
* 7311.05	45.86	39.78	6.79	35.64	9.50	2.00	49.29	74	-24.71	P	1.00
* 7311.05	34.05	39.78	6.79	35.64	9.50	2.00	37.48	54	-16.52	A	1.00
9748.05	48.15	38.53	8.33	36.60	9.50	0.55	49.46	74	-24.54	P	1.00
9748.05	38.59	38.53	8.33	36.60	9.50	0.55	39.90	54	-14.10	A	1.00
* 12191.75	-----	-----	-----	-----	9.50	0.80	-----	-----	-----	-----	1.00
14630.10	-----	-----	-----	-----	9.50	0.60	-----	-----	-----	-----	1.00
17068.45	-----	-----	-----	-----	9.50	0.53	-----	-----	-----	-----	1.00
* 19506.80	-----	-----	-----	-----	9.50	2.21	-----	-----	-----	-----	1.00
21945.15	-----	-----	-----	-----	9.50	0.72	-----	-----	-----	-----	1.00
24383.50	-----	-----	-----	-----	9.50	2.49	-----	-----	-----	-----	1.00

Note :

- The measurement was searched to 10th harmonic, Remark “---” means that the emissions level is too low to be measured.
- AF: Antenna Factor, Cable: Cable Loss, Pre-Amp: Preamplifier gain, Filter: High Pass Filter Insertion Loss (3.5GHz)
- Spectrum analyzer setting P(Peak): RBW=1MHz, VBW=1MHz, A(Average): RBW=1MHz, VBW=10Hz
- Remark “\*” means the Restricted band.
- Dist : correction to extra plate reading to 3m specification distance 1m measurement distance = -9.5dB
- The result basic equation calculation is as follow:  
 Level = Reading + AF + Cable - Preamp + Filter - Dist, Margin = Level - Limit
- The other emission levels were very low against the limit
- The test limit distance is 3M limit.
- For 802.11b mode at 11Mbps, Antenna (1).





The frequency spectrum above 1 GHz was investigated. All emissions not reported are much lower than the prescribed limits. Readings are both peak and average values.

Company	Z-Com, Inc.	Test Date	2004/08/18
Product Name	IEEE 802.11 b/g WLAN MiniPCI Card	Test By	Vincent Chen
Model Name	XG-602MB	TEMP & Humidity	25.9°C , 65%

CH6 TX				Measurement Distance at 1m Vertical polarity							
Freq. (MHz)	Reading (dBμV)	AF (dBμV)	Cable (dB)	Pre-amp (dB)	Dist (dB)	Filter (dB)	Level (dBμV/m)	Limit (dBμV/m)	Margin (dB)	Mark (P/Q/A)	Height (Meter)
2438.25	79.75	31.76	3.59	0.00	9.50	0.00	105.60	Fundamental Frequency		P	1.00
2438.25	72.90	31.76	3.59	0.00	9.50	0.00	98.75			A	1.00
* 4874.21	49.14	34.77	5.10	35.20	9.50	1.80	46.11	74	-27.89	P	1.00
* 4874.21	41.89	34.77	5.10	35.20	9.50	1.80	38.86	54	-15.14	A	1.00
* 7311.01	46.82	39.78	6.79	35.64	9.50	2.00	50.25	74	-23.75	P	1.00
* 7311.01	34.06	39.78	6.79	35.64	9.50	2.00	37.49	54	-16.51	A	1.00
9748.03	48.20	38.53	8.33	36.60	9.50	0.55	49.51	74	-24.49	P	1.00
9748.03	41.44	38.53	8.33	36.60	9.50	0.55	42.75	54	-11.25	A	1.00
* 12191.25	-----	-----	-----	-----	9.50	0.80	-----	-----	-----	-----	1.00
14629.50	-----	-----	-----	-----	9.50	0.60	-----	-----	-----	-----	1.00
17067.75	-----	-----	-----	-----	9.50	0.53	-----	-----	-----	-----	1.00
* 19506.00	-----	-----	-----	-----	9.50	2.21	-----	-----	-----	-----	1.00
21944.25	-----	-----	-----	-----	9.50	0.72	-----	-----	-----	-----	1.00
24382.50	-----	-----	-----	-----	9.50	2.49	-----	-----	-----	-----	1.00

Note :

- The measurement was searched to 10th harmonic, Remark “---” means that the emissions level is too low to be measured.
- AF: Antenna Factor, Cable: Cable Loss, Pre-Amp: Preamplifier gain, Filter: High Pass Filter Insertion Loss (3.5GHz)
- Spectrum analyzer setting P(Peak): RBW=1MHz, VBW=1MHz, A(Average): RBW=1MHz, VBW=10Hz
- Remark “\*” means the Restricted band.
- Dist : correction to extra plate reading to 3m specification distance 1m measurement distance = -9.5dB
- The result basic equation calculation is as follow:  
Level = Reading + AF + Cable - Preamp + Filter - Dist, Margin = Level - Limit
- The other emission levels were very low against the limit
- The test limit distance is 3M limit.
- For 802.11b mode at 11Mbps, Antenna (1).



The frequency spectrum above 1 GHz was investigated. All emissions not reported are much lower than the prescribed limits. Readings are both peak and average values.

Company	Z-Com, Inc.	Test Date	2004/08/18
Product Name	IEEE 802.11 b/g WLAN MiniPCI Card	Test By	Vincent Chen
Model Name	XG-602MB	TEMP & Humidity	25.9°C , 65%

CH11 TX				Measurement Distance at 1m Horizontal polarity							
Freq. (MHz)	Reading (dBμV)	AF (dBμV)	Cable (dB)	Pre-amp (dB)	Dist (dB)	Filter (dB)	Level (dBμV/m)	Limit (dBμV/m)	Margin (dB)	Mark (P/Q/A)	Height (Meter)
2463.25	78.67	31.74	3.60	0.00	9.50	0.00	104.51	Fundamental Frequency		P	1.00
2463.25	72.07	31.74	3.60	0.00	9.50	0.00	97.91			A	1.00
* 2483.60	24.40	31.72	3.61	0.00	9.50	0.00	50.23	74	-23.77	P	1.00
* 2483.60	10.60	31.72	3.61	0.00	9.50	0.00	36.43	54	-17.57	A	1.00
* 4923.95	49.31	35.10	5.12	35.24	9.50	1.60	46.39	74	-27.61	P	1.00
* 4923.95	41.35	35.10	5.12	35.24	9.50	1.60	38.43	54	-15.57	A	1.00
* 7386.02	45.59	39.75	6.84	35.62	9.50	2.00	49.06	74	-24.94	P	1.00
* 7386.02	34.54	39.75	6.84	35.62	9.50	2.00	38.01	54	-15.99	A	1.00
9847.78	47.77	38.52	8.37	36.76	9.50	0.49	48.89	74	-25.11	P	1.00
9847.78	38.29	38.52	8.37	36.76	9.50	0.49	39.41	54	-14.59	A	1.00
* 12316.25	-----	-----	-----	-----	9.50	0.80	-----	-----	-----	-----	1.00
14779.50	-----	-----	-----	-----	9.50	0.48	-----	-----	-----	-----	1.00
17242.75	-----	-----	-----	-----	9.50	0.60	-----	-----	-----	-----	1.00
* 19706.00	-----	-----	-----	-----	9.50	2.41	-----	-----	-----	-----	1.00
* 22169.25	-----	-----	-----	-----	9.50	0.70	-----	-----	-----	-----	1.00
24632.50	-----	-----	-----	-----	9.50	2.11	-----	-----	-----	-----	1.00

Note :

- The measurement was searched to 10th harmonic, Remark “---” means that the emissions level is too low to be measured.
- AF: Antenna Factor, Cable: Cable Loss, Pre-Amp: Preamplifier gain, Filter: High Pass Filter Insertion Loss (3.5GHz)
- Spectrum analyzer setting P(Peak): RBW=1MHz, VBW=1MHz, A(Average): RBW=1MHz, VBW=10Hz
- Remark “\*” means the Restricted band.
- Dist : correction to extra plate reading to 3m specification distance 1m measurement distance = -9.5dB
- The result basic equation calculation is as follow:  
Level = Reading + AF + Cable - Preamp + Filter - Dist, Margin = Level - Limit
- The other emission levels were very low against the limit
- The test limit distance is 3M limit.
- For 802.11b mode at 11Mbps, Antenna (1).



The frequency spectrum above 1 GHz was investigated. All emissions not reported are much lower than the prescribed limits. Readings are both peak and average values.

Company	Z-Com, Inc.	Test Date	2004/08/18
Product Name	IEEE 802.11 b/g WLAN MiniPCI Card	Test By	Vincent Chen
Model Name	XG-602MB	TEMP & Humidity	25.9°C , 65%

CH11 TX				Measurement Distance at 1m Vertical polarity							
Freq. (MHz)	Reading (dBμV)	AF (dBμV)	Cable (dB)	Pre-amp (dB)	Dist (dB)	Filter (dB)	Level (dBμV/m)	Limit (dBμV/m)	Margin (dB)	Mark (P/Q/A)	Height (Meter)
2463.25	80.88	31.74	3.60	0.00	9.50	0.00	106.72	Fundamental Frequency		P	1.00
2463.25	74.37	31.74	3.60	0.00	9.50	0.00	100.21			A	1.00
* 2483.60	27.70	31.72	3.61	0.00	9.50	0.00	53.53	74	-20.47	P	1.00
* 2483.60	13.80	31.72	3.61	0.00	9.50	0.00	39.63	54	-14.37	A	1.00
* 4923.93	51.14	35.10	5.12	35.24	9.50	1.60	48.22	74	-25.78	P	1.00
* 4923.93	44.78	35.10	5.12	35.24	9.50	1.60	41.86	54	-12.14	A	1.00
* 7385.95	47.01	39.75	6.84	35.62	9.50	2.00	50.48	74	-23.52	P	1.00
* 7385.95	36.45	39.75	6.84	35.62	9.50	2.00	39.92	54	-14.08	A	1.00
9847.94	48.17	38.52	8.37	36.76	9.50	0.49	49.28	74	-24.72	P	1.00
9847.94	39.79	38.52	8.37	36.76	9.50	0.49	40.90	54	-13.10	A	1.00
* 12316.25	-----	-----	-----	-----	9.50	0.80	-----	-----	-----	-----	1.00
14779.50	-----	-----	-----	-----	9.50	0.48	-----	-----	-----	-----	1.00
17242.75	-----	-----	-----	-----	9.50	0.60	-----	-----	-----	-----	1.00
* 19706.00	-----	-----	-----	-----	9.50	2.41	-----	-----	-----	-----	1.00
* 22169.25	-----	-----	-----	-----	9.50	0.70	-----	-----	-----	-----	1.00
24632.50	-----	-----	-----	-----	9.50	2.11	-----	-----	-----	-----	1.00

Note :

- The measurement was searched to 10th harmonic, Remark “---” means that the emissions level is too low to be measured.
- AF: Antenna Factor, Cable: Cable Loss, Pre-Amp: Preamplifier gain, Filter: High Pass Filter Insertion Loss (3.5GHz)
- Spectrum analyzer setting P(Peak): RBW=1MHz, VBW=1MHz, A(Average): RBW=1MHz, VBW=10Hz
- Remark “\*” means the Restricted band.
- Dist : correction to extra plate reading to 3m specification distance 1m measurement distance = -9.5dB
- The result basic equation calculation is as follow:  
Level = Reading + AF + Cable - Preamp + Filter - Dist, Margin = Level - Limit
- The other emission levels were very low against the limit
- The test limit distance is 3M limit.
- For 802.11b mode at 11Mbps, Antenna (1).



The frequency spectrum above 1 GHz was investigated. All emissions not reported are much lower than the prescribed limits. Readings are both peak and average values.

Company	Z-Com, Inc.	Test Date	2004/08/18
Product Name	IEEE 802.11 b/g WLAN MiniPCI Card	Test By	Vincent Chen
Model Name	XG-602MB	TEMP & Humidity	25.9°C , 65%

CH1 TX				Measurement Distance at 1m Horizontal polarity							
Freq. (MHz)	Reading (dBμV)	AF (dBμV)	Cable (dB)	Pre-amp (dB)	Dist (dB)	Filter (dB)	Level (dBμV/m)	Limit (dBμV/m)	Margin (dB)	Mark (P/Q/A)	Height (Meter)
* 2389.90	32.70	31.81	3.57	0.00	9.50	0.00	58.58	74	-15.42	P	1.00
* 2389.90	18.60	31.81	3.57	0.00	9.50	0.00	44.48	54	-9.52	A	1.00
2414.27	74.27	31.79	3.58	0.00	9.50	0.00	100.14	Fundamental Frequency		P	1.00
2414.27	65.95	31.79	3.58	0.00	9.50	0.00	91.82			A	1.00
* 4823.94	47.12	34.44	5.08	35.16	9.50	2.00	43.99	74	-30.01	P	1.00
* 4823.94	38.79	34.44	5.08	35.16	9.50	2.00	35.66	54	-18.34	A	1.00
7236.00	45.44	39.81	6.74	35.65	9.50	2.00	48.83	74	-25.17	P	1.00
7236.00	34.57	39.81	6.74	35.65	9.50	2.00	37.96	54	-16.04	A	1.00
9647.88	48.32	38.54	8.29	36.44	9.50	0.61	49.82	74	-24.18	P	1.00
9647.88	40.68	38.54	8.29	36.44	9.50	0.61	42.18	54	-11.82	A	1.00
* 12071.35	-----	-----	-----	-----	9.50	0.80	-----	-----	-----	-----	1.00
* 14485.62	-----	-----	-----	-----	9.50	0.68	-----	-----	-----	-----	1.00
16899.89	-----	-----	-----	-----	9.50	0.44	-----	-----	-----	-----	1.00
* 19314.16	-----	-----	-----	-----	9.50	1.98	-----	-----	-----	-----	1.00
21728.43	-----	-----	-----	-----	9.50	0.81	-----	-----	-----	-----	1.00
24142.70	-----	-----	-----	-----	9.50	2.87	-----	-----	-----	-----	1.00

Note :

- The measurement was searched to 10th harmonic, Remark “---” means that the emissions level is too low to be measured.
- AF: Antenna Factor, Cable: Cable Loss, Pre-Amp: Preamplifier gain, Filter: High Pass Filter Insertion Loss (3.5GHz)
- Spectrum analyzer setting P(Peak): RBW=1MHz, VBW=1MHz, A(Average): RBW=1MHz, VBW=10Hz
- Remark “\*” means the Restricted band.
- Dist : correction to extra plate reading to 3m specification distance 1m measurement distance = -9.5dB
- The result basic equation calculation is as follow:  
Level = Reading + AF + Cable - Preamp + Filter - Dist, Margin = Level - Limit
- The other emission levels were very low against the limit
- The test limit distance is 3M limit.
- For 802.11g mode at 6Mbps, Antenna (1).



The frequency spectrum above 1 GHz was investigated. All emissions not reported are much lower than the prescribed limits. Readings are both peak and average values.

Company	Z-Com, Inc.	Test Date	2004/08/18
Product Name	IEEE 802.11 b/g WLAN MiniPCI Card	Test By	Vincent Chen
Model Name	XG-602MB	TEMP & Humidity	25.9°C , 65%

CH1 TX				Measurement Distance at 1m Vertical polarity							
Freq. (MHz)	Reading (dBμV)	AF (dBμV)	Cable (dB)	Pre-amp (dB)	Dist (dB)	Filter (dB)	Level (dBμV/m)	Limit (dBμV/m)	Margin (dB)	Mark (P/Q/A)	Height (Meter)
* 2389.90	39.80	31.81	3.57	0.00	9.50	0.00	65.68	74	-8.32	P	1.00
* 2389.90	25.90	31.81	3.57	0.00	9.50	0.00	51.78	54	-2.22	A	1.00
2414.27	79.70	31.79	3.58	0.00	9.50	0.00	105.57	Fundamental Frequency		P	1.00
2414.27	71.42	31.79	3.58	0.00	9.50	0.00	97.29			A	1.00
* 4823.98	48.08	34.44	5.08	35.16	9.50	2.00	44.95	74	-29.05	P	1.00
* 4823.98	42.11	34.44	5.08	35.16	9.50	2.00	38.98	54	-15.02	A	1.00
7240.10	47.00	39.80	6.74	35.65	9.50	2.00	50.40	74	-23.60	P	1.00
7240.10	36.38	39.80	6.74	35.65	9.50	2.00	39.78	54	-14.22	A	1.00
9647.90	50.72	38.54	8.29	36.44	9.50	0.61	52.22	74	-21.78	P	1.00
9647.90	45.09	38.54	8.29	36.44	9.50	0.61	46.59	54	-7.41	A	1.00
* 12071.35	-----	-----	-----	-----	9.50	0.80	-----	-----	-----	-----	1.00
* 14485.62	-----	-----	-----	-----	9.50	0.68	-----	-----	-----	-----	1.00
16899.89	-----	-----	-----	-----	9.50	0.44	-----	-----	-----	-----	1.00
* 19314.16	-----	-----	-----	-----	9.50	1.98	-----	-----	-----	-----	1.00
21728.43	-----	-----	-----	-----	9.50	0.81	-----	-----	-----	-----	1.00
24142.70	-----	-----	-----	-----	9.50	2.87	-----	-----	-----	-----	1.00

Note :

- The measurement was searched to 10th harmonic, Remark “---” means that the emissions level is too low to be measured.
- AF: Antenna Factor, Cable: Cable Loss, Pre-Amp: Preamplifier gain, Filter: High Pass Filter Insertion Loss (3.5GHz)
- Spectrum analyzer setting P(Peak): RBW=1MHz, VBW=1MHz, A(Average): RBW=1MHz, VBW=10Hz
- Remark “\*” means the Restricted band.
- Dist : correction to extra plate reading to 3m specification distance 1m measurement distance = -9.5dB
- The result basic equation calculation is as follow:  
Level = Reading + AF + Cable - Preamp + Filter - Dist, Margin = Level - Limit
- The other emission levels were very low against the limit
- The test limit distance is 3M limit.
- The test data marked in gray background means the EUT emission data is located in the margin uncertainty range of emission limits.
- For 802.11g mode at 6Mbps, Antenna (1).



The frequency spectrum above 1 GHz was investigated. All emissions not reported are much lower than the prescribed limits. Readings are both peak and average values.

Company	Z-Com, Inc.	Test Date	2004/08/18
Product Name	IEEE 802.11 b/g WLAN MiniPCI Card	Test By	Vincent Chen
Model Name	XG-602MB	TEMP & Humidity	25.9°C , 65%

CH6 TX				Measurement Distance at 1m Horizontal polarity							
Freq. (MHz)	Reading (dBμV)	AF (dBμV)	Cable (dB)	Pre-amp (dB)	Dist (dB)	Filter (dB)	Level (dBμV/m)	Limit (dBμV/m)	Margin (dB)	Mark (P/Q/A)	Height (Meter)
2439.20	77.61	31.76	3.59	0.00	9.50	0.00	103.46	Fundamental Frequency		P	1.00
2439.20	69.07	31.76	3.59	0.00	9.50	0.00	94.92			A	1.00
* 4874.08	47.82	34.77	5.10	35.20	9.50	1.80	44.79	74	-29.21	P	1.00
* 4874.08	40.65	34.77	5.10	35.20	9.50	1.80	37.62	54	-16.38	A	1.00
* 7311.77	46.40	39.78	6.79	35.64	9.50	2.00	49.83	74	-24.17	P	1.00
* 7311.77	34.12	39.78	6.79	35.64	9.50	2.00	37.55	54	-16.45	A	1.00
9747.88	48.04	38.53	8.33	36.60	9.50	0.55	49.35	74	-24.65	P	1.00
9747.88	39.68	38.53	8.33	36.60	9.50	0.55	40.99	54	-13.01	A	1.00
* 12196.00	-----	-----	-----	-----	9.50	0.80	-----	-----	-----	-----	1.00
14635.20	-----	-----	-----	-----	9.50	0.59	-----	-----	-----	-----	1.00
17074.40	-----	-----	-----	-----	9.50	0.53	-----	-----	-----	-----	1.00
* 19513.60	-----	-----	-----	-----	9.50	2.21	-----	-----	-----	-----	1.00
21952.80	-----	-----	-----	-----	9.50	0.72	-----	-----	-----	-----	1.00
24392.00	-----	-----	-----	-----	9.50	2.47	-----	-----	-----	-----	1.00

Note :

- The measurement was searched to 10th harmonic, Remark “---” means that the emissions level is too low to be measured.
- AF: Antenna Factor, Cable: Cable Loss, Pre-Amp: Preamplifier gain, Filter: High Pass Filter Insertion Loss (3.5GHz)
- Spectrum analyzer setting P(Peak): RBW=1MHz, VBW=1MHz, A(Average): RBW=1MHz, VBW=10Hz
- Remark “\*” means the Restricted band.
- Dist : correction to extra plate reading to 3m specification distance 1m measurement distance = -9.5dB
- The result basic equation calculation is as follow:  
Level = Reading + AF + Cable - Preamp + Filter - Dist, Margin = Level - Limit
- The other emission levels were very low against the limit
- The test limit distance is 3M limit.
- For 802.11g mode at 6Mbps, Antenna (1).



The frequency spectrum above 1 GHz was investigated. All emissions not reported are much lower than the prescribed limits. Readings are both peak and average values.

Company	Z-Com, Inc.	Test Date	2004/08/18
Product Name	IEEE 802.11 b/g WLAN MiniPCI Card	Test By	Vincent Chen
Model Name	XG-602MB	TEMP & Humidity	25.9°C , 65%

CH6 TX				Measurement Distance at 1m Vertical polarity							
Freq. (MHz)	Reading (dBμV)	AF (dBμV)	Cable (dB)	Pre-amp (dB)	Dist (dB)	Filter (dB)	Level (dBμV/m)	Limit (dBμV/m)	Margin (dB)	Mark (P/Q/A)	Height (Meter)
2435.34	80.47	31.76	3.59	0.00	9.50	0.00	106.33	Fundamental Frequency		P	1.00
2435.34	71.85	31.76	3.59	0.00	9.50	0.00	97.71			A	1.00
* 4874.07	48.99	34.77	5.10	35.20	9.50	1.80	45.96	74	-28.04	P	1.00
* 4874.07	42.27	34.77	5.10	35.20	9.50	1.80	39.24	54	-14.76	A	1.00
* 7325.72	46.41	39.77	6.80	35.63	9.50	2.00	49.85	74	-24.15	P	1.00
* 7325.72	34.20	39.77	6.80	35.63	9.50	2.00	37.64	54	-16.36	A	1.00
9748.10	47.92	38.53	8.33	36.60	9.50	0.55	49.23	74	-24.77	P	1.00
9748.10	40.48	38.53	8.33	36.60	9.50	0.55	41.79	54	-12.21	A	1.00
* 12176.70	-----	-----	-----	-----	9.50	0.80	-----	-----	-----	-----	1.00
14612.04	-----	-----	-----	-----	9.50	0.61	-----	-----	-----	-----	1.00
17047.38	-----	-----	-----	-----	9.50	0.52	-----	-----	-----	-----	1.00
* 19482.72	-----	-----	-----	-----	9.50	2.18	-----	-----	-----	-----	1.00
21918.06	-----	-----	-----	-----	9.50	0.73	-----	-----	-----	-----	1.00
24353.40	-----	-----	-----	-----	9.50	2.53	-----	-----	-----	-----	1.00

Note :

- The measurement was searched to 10th harmonic, Remark “---” means that the emissions level is too low to be measured.
- AF: Antenna Factor, Cable: Cable Loss, Pre-Amp: Preamplifier gain, Filter: High Pass Filter Insertion Loss (3.5GHz)
- Spectrum analyzer setting P(Peak): RBW=1MHz, VBW=1MHz, A(Average): RBW=1MHz, VBW=10Hz
- Remark “\*” means the Restricted band.
- Dist : correction to extra plate reading to 3m specification distance 1m measurement distance = -9.5dB
- The result basic equation calculation is as follow:  
Level = Reading + AF + Cable - Preamp + Filter - Dist, Margin = Level - Limit
- The other emission levels were very low against the limit
- The test limit distance is 3M limit.
- For 802.11g mode at 6Mbps, Antenna (1).



The frequency spectrum above 1 GHz was investigated. All emissions not reported are much lower than the prescribed limits. Readings are both peak and average values.

Company	Z-Com, Inc.	Test Date	2004/08/18
Product Name	IEEE 802.11 b/g WLAN MiniPCI Card	Test By	Vincent Chen
Model Name	XG-602MB	TEMP & Humidity	25.9°C , 65%

CH11 TX				Measurement Distance at 1m Horizontal polarity							
Freq. (MHz)	Reading (dBμV)	AF (dBμV)	Cable (dB)	Pre-amp (dB)	Dist (dB)	Filter (dB)	Level (dBμV/m)	Limit (dBμV/m)	Margin (dB)	Mark (P/Q/A)	Height (Meter)
2456.53	76.16	31.74	3.60	0.00	9.50	0.00	102.00	Fundamental Frequency		P	1.00
2456.53	67.83	31.74	3.60	0.00	9.50	0.00	93.67			A	1.00
* 2483.60	35.20	31.72	3.61	0.00	9.50	0.00	61.03	74	-12.97	P	1.00
* 2483.60	22.00	31.72	3.61	0.00	9.50	0.00	47.83	54	-6.17	A	1.00
* 4923.95	48.24	35.10	5.12	35.24	9.50	1.60	45.32	74	-28.68	P	1.00
* 4923.95	41.02	35.10	5.12	35.24	9.50	1.60	38.10	54	-15.90	A	1.00
* 7386.02	45.82	39.75	6.84	35.62	9.50	2.00	49.29	74	-24.71	P	1.00
* 7386.02	34.49	39.75	6.84	35.62	9.50	2.00	37.96	54	-16.04	A	1.00
9847.78	47.37	38.52	8.37	36.76	9.50	0.49	48.49	74	-25.51	P	1.00
9847.78	38.83	38.52	8.37	36.76	9.50	0.49	39.95	54	-14.05	A	1.00
* 12282.65	-----	-----	-----	-----	9.50	0.80	-----	-----	-----	-----	1.00
14739.18	-----	-----	-----	-----	9.50	0.51	-----	-----	-----	-----	1.00
17195.71	-----	-----	-----	-----	9.50	0.58	-----	-----	-----	-----	1.00
* 19652.24	-----	-----	-----	-----	9.50	2.35	-----	-----	-----	-----	1.00
* 22108.77	-----	-----	-----	-----	9.50	0.70	-----	-----	-----	-----	1.00
24565.30	-----	-----	-----	-----	9.50	2.21	-----	-----	-----	-----	1.00

Note :

- The measurement was searched to 10th harmonic, Remark "---" means that the emissions level is too low to be measured.
- AF: Antenna Factor, Cable: Cable Loss, Pre-Amp: Preamplifier gain, Filter: High Pass Filter Insertion Loss (3.5GHz)
- Spectrum analyzer setting P(Peak): RBW=1MHz, VBW=1MHz, A(Average): RBW=1MHz, VBW=10Hz
- Remark "\*" means the Restricted band.
- Dist : correction to extra plate reading to 3m specification distance 1m measurement distance = -9.5dB
- The result basic equation calculation is as follow:  
Level = Reading + AF + Cable - Preamp + Filter - Dist, Margin = Level - Limit
- The other emission levels were very low against the limit
- The test limit distance is 3M limit.
- For 802.11g mode at 6Mbps, Antenna (1).





The frequency spectrum above 1 GHz was investigated. All emissions not reported are much lower than the prescribed limits. Readings are both peak and average values.

Company	Z-Com, Inc.	Test Date	2004/08/18
Product Name	IEEE 802.11 b/g WLAN MiniPCI Card	Test By	Vincent Chen
Model Name	XG-602MB	TEMP & Humidity	25.9°C , 65%

CH11 TX				Measurement Distance at 1m Vertical polarity							
Freq. (MHz)	Reading (dBμV)	AF (dBμV)	Cable (dB)	Pre-amp (dB)	Dist (dB)	Filter (dB)	Level (dBμV/m)	Limit (dBμV/m)	Margin (dB)	Mark (P/Q/A)	Height (Meter)
2456.53	78.55	31.74	3.60	0.00	9.50	0.00	104.39	Fundamental Frequency		P	1.00
2456.53	70.00	31.74	3.60	0.00	9.50	0.00	95.84			A	1.00
* 2483.60	38.20	31.72	3.61	0.00	9.50	0.00	64.03	74	-9.97	P	1.00
* 2483.60	24.90	31.72	3.61	0.00	9.50	0.00	50.73	54	-3.27	A	1.00
* 4923.94	50.40	35.10	5.12	35.24	9.50	1.60	47.48	74	-26.52	P	1.00
* 4923.94	43.98	35.10	5.12	35.24	9.50	1.60	41.06	54	-12.94	A	1.00
* 7388.10	48.04	39.74	6.84	35.62	9.50	2.00	51.51	74	-22.49	P	1.00
* 7388.10	36.85	39.74	6.84	35.62	9.50	2.00	40.32	54	-13.68	A	1.00
9847.93	48.22	38.52	8.37	36.76	9.50	0.49	49.34	74	-24.66	P	1.00
9847.93	39.94	38.52	8.37	36.76	9.50	0.49	41.06	54	-12.94	A	1.00
* 12282.65	-----	-----	-----	-----	9.50	0.80	-----	-----	-----	-----	1.00
14739.18	-----	-----	-----	-----	9.50	0.51	-----	-----	-----	-----	1.00
17195.71	-----	-----	-----	-----	9.50	0.58	-----	-----	-----	-----	1.00
* 19652.24	-----	-----	-----	-----	9.50	2.35	-----	-----	-----	-----	1.00
* 22108.77	-----	-----	-----	-----	9.50	0.70	-----	-----	-----	-----	1.00
24565.30	-----	-----	-----	-----	9.50	2.21	-----	-----	-----	-----	1.00

Note :

- The measurement was searched to 10th harmonic, Remark “---” means that the emissions level is too low to be measured.
- AF: Antenna Factor, Cable: Cable Loss, Pre-Amp: Preamplifier gain, Filter: High Pass Filter Insertion Loss (3.5GHz)
- Spectrum analyzer setting P(Peak): RBW=1MHz, VBW=1MHz, A(Average): RBW=1MHz, VBW=10Hz
- Remark “\*” means the Restricted band.
- Dist : correction to extra plate reading to 3m specification distance 1m measurement distance = -9.5dB
- The result basic equation calculation is as follow:  
Level = Reading + AF + Cable - Preamp + Filter - Dist, Margin = Level - Limit
- The other emission levels were very low against the limit
- The test limit distance is 3M limit.
- For 802.11g mode at 6Mbps, Antenna (1).



The frequency spectrum above 1 GHz was investigated. All emissions not reported are much lower than the prescribed limits. Readings are both peak and average values.

Company	Z-Com, Inc.	Test Date	2005/04/29
Product Name	IEEE 802.11 b/g WLAN MiniPCI Card	Test By	Vincent Chen
Model Name	XG-602MB	TEMP & Humidity	32.5°C , 56%

CH1 TX				Measurement Distance at 1m Horizontal polarity							
Freq. (MHz)	Reading (dBμV)	AF (dBμV)	Cable (dB)	Pre-amp (dB)	Dist (dB)	Filter (dB)	Level (dBμV/m)	Limit (dBμV/m)	Margin (dB)	Mark (P/Q/A)	Height (Meter)
* 2390.00	26.80	31.81	3.57	0.00	9.50	0.00	52.68	74	-21.32	P	1.00
* 2390.00	15.52	31.81	3.57	0.00	9.50	0.00	41.40	54	-12.60	A	1.00
2411.21	75.37	31.79	3.58	0.00	9.50	0.00	101.24	Fundamental Frequency		P	1.00
2411.21	68.49	31.79	3.58	0.00	9.50	0.00	94.36			A	1.00
* 4823.92	47.37	34.44	5.08	35.16	9.50	2.00	44.24	74	-29.76	P	1.00
* 4823.92	38.95	34.44	5.08	35.16	9.50	2.00	35.82	54	-18.18	A	1.00
7236.00	45.38	39.81	6.74	35.65	9.50	2.00	48.77	74	-25.23	P	1.00
7236.00	34.18	39.81	6.74	35.65	9.50	2.00	37.57	54	-16.43	A	1.00
9647.85	48.12	38.54	8.29	36.44	9.50	0.61	49.62	74	-24.38	P	1.00
9647.85	39.90	38.54	8.29	36.44	9.50	0.61	41.40	54	-12.60	A	1.00
* 12056.05	-----	-----	-----	-----	9.50	0.80	-----	-----	-----	-----	1.00
14467.26	-----	-----	-----	-----	9.50	0.66	-----	-----	-----	-----	1.00
16878.47	-----	-----	-----	-----	9.50	0.43	-----	-----	-----	-----	1.00
* 19289.68	-----	-----	-----	-----	9.50	1.95	-----	-----	-----	-----	1.00
21700.89	-----	-----	-----	-----	9.50	0.82	-----	-----	-----	-----	1.00
24112.10	-----	-----	-----	-----	9.50	2.92	-----	-----	-----	-----	1.00

Note :

- The measurement was searched to 10th harmonic, Remark “---” means that the emissions level is too low to be measured.
- AF: Antenna Factor, Cable: Cable Loss, Pre-Amp: Preamplifier gain, Filter: High Pass Filter Insertion Loss (3.5GHz)
- Spectrum analyzer setting P(Peak): RBW=1MHz, VBW=1MHz, A(Average): RBW=1MHz, VBW=10Hz
- Remark “\*” means the Restricted band.
- Dist : correction to extra plate reading to 3m specification distance 1m measurement distance = -9.5dB
- The result basic equation calculation is as follow:  
 $Level = Reading + AF + Cable - Preamp + Filter - Dist$ ,  $Margin = Level - Limit$
- The other emission levels were very low against the limit
- The test limit distance is 3M limit.
- For 802.11b mode at 11Mbps, Antenna (2).



The frequency spectrum above 1 GHz was investigated. All emissions not reported are much lower than the prescribed limits. Readings are both peak and average values.

Company	Z-Com, Inc.	Test Date	2005/04/29
Product Name	IEEE 802.11 b/g WLAN MiniPCI Card	Test By	Vincent Chen
Model Name	XG-602MB	TEMP & Humidity	32.5°C , 56%

CH1 TX				Measurement Distance at 1m Vertical polarity							
Freq. (MHz)	Reading (dBμV)	AF (dBμV)	Cable (dB)	Pre-amp (dB)	Dist (dB)	Filter (dB)	Level (dBμV/m)	Limit (dBμV/m)	Margin (dB)	Mark (P/Q/A)	Height (Meter)
* 2390.00	29.10	31.81	3.57	0.00	9.50	0.00	54.98	74	-19.02	P	1.00
* 2390.00	16.43	31.81	3.57	0.00	9.50	0.00	42.31	54	-11.69	A	1.00
2411.46	79.48	31.79	3.58	0.00	9.50	0.00	105.35	Fundamental Frequency		P	1.00
2411.46	72.63	31.79	3.58	0.00	9.50	0.00	98.50			A	1.00
* 4824.00	49.90	34.44	5.08	35.16	9.50	2.00	46.77	74	-27.23	P	1.00
* 4824.00	41.25	34.44	5.08	35.16	9.50	2.00	38.12	54	-15.88	A	1.00
7237.78	45.47	39.80	6.74	35.65	9.50	2.00	48.86	74	-25.14	P	1.00
7237.78	35.71	39.80	6.74	35.65	9.50	2.00	39.10	54	-14.90	A	1.00
9647.86	49.86	38.54	8.29	36.44	9.50	0.61	51.36	74	-22.64	P	1.00
9647.86	43.59	38.54	8.29	36.44	9.50	0.61	45.09	54	-8.91	A	1.00
* 12057.30	-----	-----	-----	-----	9.50	0.80	-----	-----	-----	-----	1.00
14468.76	-----	-----	-----	-----	9.50	0.66	-----	-----	-----	-----	1.00
16880.22	-----	-----	-----	-----	9.50	0.43	-----	-----	-----	-----	1.00
* 19291.68	-----	-----	-----	-----	9.50	1.95	-----	-----	-----	-----	1.00
21703.14	-----	-----	-----	-----	9.50	0.82	-----	-----	-----	-----	1.00
24114.60	-----	-----	-----	-----	9.50	2.92	-----	-----	-----	-----	1.00

Note :

- The measurement was searched to 10th harmonic, Remark “---” means that the emissions level is too low to be measured.
- AF: Antenna Factor, Cable: Cable Loss, Pre-Amp: Preamplifier gain, Filter: High Pass Filter Insertion Loss (3.5GHz)
- Spectrum analyzer setting P(Peak): RBW=1MHz, VBW=1MHz, A(Average): RBW=1MHz, VBW=10Hz
- Remark “\*” means the Restricted band.
- Dist : correction to extra plate reading to 3m specification distance 1m measurement distance = -9.5dB
- The result basic equation calculation is as follow:  
 $Level = Reading + AF + Cable - Preamp + Filter - Dist$ ,  $Margin = Level - Limit$
- The other emission levels were very low against the limit
- The test limit distance is 3M limit.
- For 802.11b mode at 11Mbps, Antenna (2).



The frequency spectrum above 1 GHz was investigated. All emissions not reported are much lower than the prescribed limits. Readings are both peak and average values.

Company	Z-Com, Inc.	Test Date	2005/04/29
Product Name	IEEE 802.11 b/g WLAN MiniPCI Card	Test By	Vincent Chen
Model Name	XG-602MB	TEMP & Humidity	32.5°C , 56%

CH6 TX				Measurement Distance at 1m Horizontal polarity							
Freq. (MHz)	Reading (dBμV)	AF (dBμV)	Cable (dB)	Pre-amp (dB)	Dist (dB)	Filter (dB)	Level (dBμV/m)	Limit (dBμV/m)	Margin (dB)	Mark (P/Q/A)	Height (Meter)
2438.35	74.17	31.76	3.59	0.00	9.50	0.00	100.02	Fundamental Frequency		P	1.00
2438.35	67.21	31.76	3.59	0.00	9.50	0.00	93.06			A	1.00
* 4873.91	47.37	34.77	5.10	35.20	9.50	1.80	44.34	74	-29.66	P	1.00
* 4873.91	39.36	34.77	5.10	35.20	9.50	1.80	36.33	54	-17.67	A	1.00
* 7311.05	45.77	39.78	6.79	35.64	9.50	2.00	49.20	74	-24.80	P	1.00
* 7311.05	33.82	39.78	6.79	35.64	9.50	2.00	37.25	54	-16.75	A	1.00
9748.05	47.65	38.53	8.33	36.60	9.50	0.55	48.96	74	-25.04	P	1.00
9748.05	38.24	38.53	8.33	36.60	9.50	0.55	39.55	54	-14.45	A	1.00
* 12191.75	-----	-----	-----	-----	9.50	0.80	-----	-----	-----	-----	1.00
14630.10	-----	-----	-----	-----	9.50	0.60	-----	-----	-----	-----	1.00
17068.45	-----	-----	-----	-----	9.50	0.53	-----	-----	-----	-----	1.00
* 19506.80	-----	-----	-----	-----	9.50	2.21	-----	-----	-----	-----	1.00
21945.15	-----	-----	-----	-----	9.50	0.72	-----	-----	-----	-----	1.00
24383.50	-----	-----	-----	-----	9.50	2.49	-----	-----	-----	-----	1.00

Note :

- The measurement was searched to 10th harmonic, Remark “---” means that the emissions level is too low to be measured.
- AF: Antenna Factor, Cable: Cable Loss, Pre-Amp: Preamplifier gain, Filter: High Pass Filter Insertion Loss (3.5GHz)
- Spectrum analyzer setting P(Peak): RBW=1MHz, VBW=1MHz, A(Average): RBW=1MHz, VBW=10Hz
- Remark “\*” means the Restricted band.
- Dist : correction to extra plate reading to 3m specification distance 1m measurement distance = -9.5dB
- The result basic equation calculation is as follow:  
 $Level = Reading + AF + Cable - Preamp + Filter - Dist$ ,  $Margin = Level - Limit$
- The other emission levels were very low against the limit
- The test limit distance is 3M limit.
- For 802.11b mode at 11Mbps, Antenna (2).



The frequency spectrum above 1 GHz was investigated. All emissions not reported are much lower than the prescribed limits. Readings are both peak and average values.

Company	Z-Com, Inc.	Test Date	2005/04/29
Product Name	IEEE 802.11 b/g WLAN MiniPCI Card	Test By	Vincent Chen
Model Name	XG-602MB	TEMP & Humidity	32.5°C , 56%

CH6 TX				Measurement Distance at 1m Vertical polarity							
Freq. (MHz)	Reading (dBμV)	AF (dBμV)	Cable (dB)	Pre-amp (dB)	Dist (dB)	Filter (dB)	Level (dBμV/m)	Limit (dBμV/m)	Margin (dB)	Mark (P/Q/A)	Height (Meter)
2438.25	79.46	31.76	3.59	0.00	9.50	0.00	105.31	Fundamental Frequency		P	1.00
2438.25	72.56	31.76	3.59	0.00	9.50	0.00	98.41			A	1.00
* 4873.84	50.94	34.77	5.10	35.20	9.50	1.80	47.91	74	-26.09	P	1.00
* 4873.84	41.39	34.77	5.10	35.20	9.50	1.80	38.36	54	-15.64	A	1.00
* 7311.60	49.12	39.78	6.79	35.64	9.50	2.00	52.55	74	-21.45	P	1.00
* 7311.60	38.44	39.78	6.79	35.64	9.50	2.00	41.87	54	-12.13	A	1.00
9747.81	49.34	38.53	8.33	36.60	9.50	0.55	50.65	74	-23.35	P	1.00
9747.81	42.63	38.53	8.33	36.60	9.50	0.55	43.94	54	-10.06	A	1.00
* 12191.25	-----	-----	-----	-----	9.50	0.80	-----	-----	-----	-----	1.00
14629.50	-----	-----	-----	-----	9.50	0.60	-----	-----	-----	-----	1.00
17067.75	-----	-----	-----	-----	9.50	0.53	-----	-----	-----	-----	1.00
* 19506.00	-----	-----	-----	-----	9.50	2.21	-----	-----	-----	-----	1.00
21944.25	-----	-----	-----	-----	9.50	0.72	-----	-----	-----	-----	1.00
24382.50	-----	-----	-----	-----	9.50	2.49	-----	-----	-----	-----	1.00

Note :

- The measurement was searched to 10th harmonic, Remark “---” means that the emissions level is too low to be measured.
- AF: Antenna Factor, Cable: Cable Loss, Pre-Amp: Preamplifier gain, Filter: High Pass Filter Insertion Loss (3.5GHz)
- Spectrum analyzer setting P(Peak): RBW=1MHz, VBW=1MHz, A(Average): RBW=1MHz, VBW=10Hz
- Remark “\*” means the Restricted band.
- Dist : correction to extra plate reading to 3m specification distance 1m measurement distance = -9.5dB
- The result basic equation calculation is as follow:  
 $Level = Reading + AF + Cable - Preamp + Filter - Dist$ ,  $Margin = Level - Limit$
- The other emission levels were very low against the limit
- The test limit distance is 3M limit.
- For 802.11b mode at 11Mbps, Antenna (2).



The frequency spectrum above 1 GHz was investigated. All emissions not reported are much lower than the prescribed limits. Readings are both peak and average values.

Company	Z-Com, Inc.	Test Date	2005/04/29
Product Name	IEEE 802.11 b/g WLAN MiniPCI Card	Test By	Vincent Chen
Model Name	XG-602MB	TEMP & Humidity	32.5°C , 56%

CH11 TX				Measurement Distance at 1m Horizontal polarity							
Freq. (MHz)	Reading (dBμV)	AF (dBμV)	Cable (dB)	Pre-amp (dB)	Dist (dB)	Filter (dB)	Level (dBμV/m)	Limit (dBμV/m)	Margin (dB)	Mark (P/Q/A)	Height (Meter)
2463.25	72.21	31.74	3.60	0.00	9.50	0.00	98.05	Fundamental Frequency		P	1.00
2463.25	65.16	31.74	3.60	0.00	9.50	0.00	91.00			A	1.00
* 2483.60	26.54	31.72	3.61	0.00	9.50	0.00	52.37	74	-21.63	P	1.00
* 2483.60	14.50	31.72	3.61	0.00	9.50	0.00	40.33	54	-13.67	A	1.00
* 4923.95	49.10	35.10	5.12	35.24	9.50	1.60	46.18	74	-27.82	P	1.00
* 4923.95	41.57	35.10	5.12	35.24	9.50	1.60	38.65	54	-15.35	A	1.00
* 7386.02	45.81	39.75	6.84	35.62	9.50	2.00	49.28	74	-24.72	P	1.00
* 7386.02	34.21	39.75	6.84	35.62	9.50	2.00	37.68	54	-16.32	A	1.00
9847.78	47.56	38.52	8.37	36.76	9.50	0.49	48.68	74	-25.32	P	1.00
9847.78	37.98	38.52	8.37	36.76	9.50	0.49	39.10	54	-14.90	A	1.00
* 12316.25	-----	-----	-----	-----	9.50	0.80	-----	-----	-----	-----	1.00
14779.50	-----	-----	-----	-----	9.50	0.48	-----	-----	-----	-----	1.00
17242.75	-----	-----	-----	-----	9.50	0.60	-----	-----	-----	-----	1.00
* 19706.00	-----	-----	-----	-----	9.50	2.41	-----	-----	-----	-----	1.00
* 22169.25	-----	-----	-----	-----	9.50	0.70	-----	-----	-----	-----	1.00
24632.50	-----	-----	-----	-----	9.50	2.11	-----	-----	-----	-----	1.00

Note :

- The measurement was searched to 10th harmonic, Remark “---” means that the emissions level is too low to be measured.
- AF: Antenna Factor, Cable: Cable Loss, Pre-Amp: Preamplifier gain, Filter: High Pass Filter Insertion Loss (3.5GHz)
- Spectrum analyzer setting P(Peak): RBW=1MHz, VBW=1MHz, A(Average): RBW=1MHz, VBW=10Hz
- Remark “\*” means the Restricted band.
- Dist : correction to extra plate reading to 3m specification distance 1m measurement distance = -9.5dB
- The result basic equation calculation is as follow:  
 Level = Reading + AF + Cable - Preamp + Filter - Dist, Margin = Level - Limit
- The other emission levels were very low against the limit
- The test limit distance is 3M limit.
- For 802.11b mode at 11Mbps, Antenna (2).



The frequency spectrum above 1 GHz was investigated. All emissions not reported are much lower than the prescribed limits. Readings are both peak and average values.

Company	Z-Com, Inc.	Test Date	2005/04/29
Product Name	IEEE 802.11 b/g WLAN MiniPCI Card	Test By	Vincent Chen
Model Name	XG-602MB	TEMP & Humidity	32.5°C , 56%

CH11 TX				Measurement Distance at 1m Vertical polarity							
Freq. (MHz)	Reading (dBμV)	AF (dBμV)	Cable (dB)	Pre-amp (dB)	Dist (dB)	Filter (dB)	Level (dBμV/m)	Limit (dBμV/m)	Margin (dB)	Mark (P/Q/A)	Height (Meter)
2463.25	77.75	31.74	3.60	0.00	9.50	0.00	103.59	Fundamental Frequency		P	1.00
2462.27	70.62	31.74	3.60	0.00	9.50	0.00	96.46			A	1.00
* 2483.60	28.48	31.72	3.61	0.00	9.50	0.00	54.31	74	-19.69	P	1.00
* 2483.60	15.52	31.72	3.61	0.00	9.50	0.00	41.35	54	-12.65	A	1.00
* 4923.93	52.14	35.10	5.12	35.24	9.50	1.60	49.22	74	-24.78	P	1.00
* 4923.93	44.96	35.10	5.12	35.24	9.50	1.60	42.04	54	-11.96	A	1.00
* 7385.95	46.77	39.75	6.84	35.62	9.50	2.00	50.24	74	-23.76	P	1.00
* 7385.95	35.28	39.75	6.84	35.62	9.50	2.00	38.75	54	-15.25	A	1.00
9847.94	48.56	38.52	8.37	36.76	9.50	0.49	49.67	74	-24.33	P	1.00
9847.94	40.24	38.52	8.37	36.76	9.50	0.49	41.35	54	-12.65	A	1.00
* 12316.25	-----	-----	-----	-----	9.50	0.80	-----	-----	-----	-----	1.00
14779.50	-----	-----	-----	-----	9.50	0.48	-----	-----	-----	-----	1.00
17242.75	-----	-----	-----	-----	9.50	0.60	-----	-----	-----	-----	1.00
* 19706.00	-----	-----	-----	-----	9.50	2.41	-----	-----	-----	-----	1.00
* 22169.25	-----	-----	-----	-----	9.50	0.70	-----	-----	-----	-----	1.00
24632.50	-----	-----	-----	-----	9.50	2.11	-----	-----	-----	-----	1.00

Note :

- The measurement was searched to 10th harmonic, Remark "---" means that the emissions level is too low to be measured.
- AF: Antenna Factor, Cable: Cable Loss, Pre-Amp: Preamplifier gain, Filter: High Pass Filter Insertion Loss (3.5GHz)
- Spectrum analyzer setting P(Peak): RBW=1MHz, VBW=1MHz, A(Average): RBW=1MHz, VBW=10Hz
- Remark "\*" means the Restricted band.
- Dist : correction to extra plate reading to 3m specification distance 1m measurement distance = -9.5dB
- The result basic equation calculation is as follow:  
Level = Reading + AF + Cable - Preamp + Filter - Dist, Margin = Level - Limit
- The other emission levels were very low against the limit
- The test limit distance is 3M limit.
- For 802.11b mode at 11Mbps, Antenna (2).



The frequency spectrum above 1 GHz was investigated. All emissions not reported are much lower than the prescribed limits. Readings are both peak and average values.

Company	Z-Com, Inc.	Test Date	2005/04/29
Product Name	IEEE 802.11 b/g WLAN MiniPCI Card	Test By	Vincent Chen
Model Name	XG-602MB	TEMP & Humidity	32.5°C , 56%

CH1 TX				Measurement Distance at 1m Horizontal polarity							
Freq. (MHz)	Reading (dBμV)	AF (dBμV)	Cable (dB)	Pre-amp (dB)	Dist (dB)	Filter (dB)	Level (dBμV/m)	Limit (dBμV/m)	Margin (dB)	Mark (P/Q/A)	Height (Meter)
* 2389.90	36.24	31.81	3.57	0.00	9.50	0.00	62.12	74	-11.88	P	1.00
* 2389.90	21.43	31.81	3.57	0.00	9.50	0.00	47.31	54	-6.69	A	1.00
2414.27	74.16	31.79	3.58	0.00	9.50	0.00	100.03	Fundamental Frequency		P	1.00
2414.27	65.27	31.79	3.58	0.00	9.50	0.00	91.14			A	1.00
* 4823.94	47.19	34.44	5.08	35.16	9.50	2.00	44.06	74	-29.94	P	1.00
* 4823.94	38.46	34.44	5.08	35.16	9.50	2.00	35.33	54	-18.67	A	1.00
7236.00	45.21	39.81	6.74	35.65	9.50	2.00	48.60	74	-25.40	P	1.00
7236.00	34.06	39.81	6.74	35.65	9.50	2.00	37.45	54	-16.55	A	1.00
9647.88	48.20	38.54	8.29	36.44	9.50	0.61	49.70	74	-24.30	P	1.00
9647.88	41.69	38.54	8.29	36.44	9.50	0.61	43.19	54	-10.81	A	1.00
* 12071.35	-----	-----	-----	-----	9.50	0.80	-----	-----	-----	-----	1.00
* 14485.62	-----	-----	-----	-----	9.50	0.68	-----	-----	-----	-----	1.00
16899.89	-----	-----	-----	-----	9.50	0.44	-----	-----	-----	-----	1.00
* 19314.16	-----	-----	-----	-----	9.50	1.98	-----	-----	-----	-----	1.00
21728.43	-----	-----	-----	-----	9.50	0.81	-----	-----	-----	-----	1.00
24142.70	-----	-----	-----	-----	9.50	2.87	-----	-----	-----	-----	1.00

Note :

- The measurement was searched to 10th harmonic, Remark “---” means that the emissions level is too low to be measured.
- AF: Antenna Factor, Cable: Cable Loss, Pre-Amp: Preamplifier gain, Filter: High Pass Filter Insertion Loss (3.5GHz)
- Spectrum analyzer setting P(Peak): RBW=1MHz, VBW=1MHz, A(Average): RBW=1MHz, VBW=10Hz
- Remark “\*” means the Restricted band.
- Dist : correction to extra plate reading to 3m specification distance 1m measurement distance = -9.5dB
- The result basic equation calculation is as follow:  
Level = Reading + AF + Cable - Preamp + Filter - Dist, Margin = Level - Limit
- The other emission levels were very low against the limit
- The test limit distance is 3M limit.
- For 802.11g mode at 6Mbps, Antenna (2).





The frequency spectrum above 1 GHz was investigated. All emissions not reported are much lower than the prescribed limits. Readings are both peak and average values.

Company	Z-Com, Inc.	Test Date	2005/04/29
Product Name	IEEE 802.11 b/g WLAN MiniPCI Card	Test By	Vincent Chen
Model Name	XG-602MB	TEMP & Humidity	32.5°C , 56%

CH1 TX				Measurement Distance at 1m Vertical polarity							
Freq. (MHz)	Reading (dBμV)	AF (dBμV)	Cable (dB)	Pre-amp (dB)	Dist (dB)	Filter (dB)	Level (dBμV/m)	Limit (dBμV/m)	Margin (dB)	Mark (P/Q/A)	Height (Meter)
* 2390.00	39.60	31.81	3.57	0.00	9.50	0.00	65.48	74	-8.52	P	1.00
* 2390.00	24.96	31.81	3.57	0.00	9.50	0.00	50.84	54	-3.16	A	1.00
2414.27	77.02	31.79	3.58	0.00	9.50	0.00	102.89	Fundamental Frequency		P	1.00
2414.27	68.20	31.79	3.58	0.00	9.50	0.00	94.07			A	1.00
* 4823.98	48.08	34.44	5.08	35.16	9.50	2.00	44.95	74	-29.05	P	1.00
* 4823.98	42.11	34.44	5.08	35.16	9.50	2.00	38.98	54	-15.02	A	1.00
7240.10	47.58	39.80	6.74	35.65	9.50	2.00	50.98	74	-23.02	P	1.00
7240.10	36.52	39.80	6.74	35.65	9.50	2.00	39.92	54	-14.08	A	1.00
9647.90	50.06	38.54	8.29	36.44	9.50	0.61	51.56	74	-22.44	P	1.00
9647.90	43.37	38.54	8.29	36.44	9.50	0.61	44.87	54	-9.13	A	1.00
* 12071.35	-----	-----	-----	-----	9.50	0.80	-----	-----	-----	-----	1.00
* 14485.62	-----	-----	-----	-----	9.50	0.68	-----	-----	-----	-----	1.00
16899.89	-----	-----	-----	-----	9.50	0.44	-----	-----	-----	-----	1.00
* 19314.16	-----	-----	-----	-----	9.50	1.98	-----	-----	-----	-----	1.00
21728.43	-----	-----	-----	-----	9.50	0.81	-----	-----	-----	-----	1.00
24142.70	-----	-----	-----	-----	9.50	2.87	-----	-----	-----	-----	1.00

Note :

- The measurement was searched to 10th harmonic, Remark “---” means that the emissions level is too low to be measured.
- AF: Antenna Factor, Cable: Cable Loss, Pre-Amp: Preamplifier gain, Filter: High Pass Filter Insertion Loss (3.5GHz)
- Spectrum analyzer setting P(Peak): RBW=1MHz, VBW=1MHz, A(Average): RBW=1MHz, VBW=10Hz
- Remark “\*” means the Restricted band.
- Dist : correction to extra plate reading to 3m specification distance 1m measurement distance = -9.5dB
- The result basic equation calculation is as follow:  
Level = Reading + AF + Cable - Preamp + Filter - Dist, Margin = Level - Limit
- The other emission levels were very low against the limit
- The test limit distance is 3M limit.
- The test data marked in gray background means the EUT emission data is located in the margin uncertainty range of emission limits.
- For 802.11g mode at 6Mbps, Antenna (2).



The frequency spectrum above 1 GHz was investigated. All emissions not reported are much lower than the prescribed limits. Readings are both peak and average values.

Company	Z-Com, Inc.	Test Date	2005/04/29
Product Name	IEEE 802.11 b/g WLAN MiniPCI Card	Test By	Vincent Chen
Model Name	XG-602MB	TEMP & Humidity	32.5°C , 56%

CH6 TX				Measurement Distance at 1m Horizontal polarity							
Freq. (MHz)	Reading (dBμV)	AF (dBμV)	Cable (dB)	Pre-amp (dB)	Dist (dB)	Filter (dB)	Level (dBμV/m)	Limit (dBμV/m)	Margin (dB)	Mark (P/Q/A)	Height (Meter)
2439.20	73.21	31.76	3.59	0.00	9.50	0.00	99.06	Fundamental Frequency		P	1.00
2439.20	64.50	31.76	3.59	0.00	9.50	0.00	90.35			A	1.00
* 4874.08	46.59	34.77	5.10	35.20	9.50	1.80	43.56	74	-30.44	P	1.00
* 4874.08	38.70	34.77	5.10	35.20	9.50	1.80	35.67	54	-18.33	A	1.00
* 7311.77	46.02	39.78	6.79	35.64	9.50	2.00	49.45	74	-24.55	P	1.00
* 7311.77	34.25	39.78	6.79	35.64	9.50	2.00	37.68	54	-16.32	A	1.00
9747.88	47.80	38.53	8.33	36.60	9.50	0.55	49.11	74	-24.89	P	1.00
9747.88	40.32	38.53	8.33	36.60	9.50	0.55	41.63	54	-12.37	A	1.00
* 12196.00	-----	-----	-----	-----	9.50	0.80	-----	-----	-----	-----	1.00
14635.20	-----	-----	-----	-----	9.50	0.59	-----	-----	-----	-----	1.00
17074.40	-----	-----	-----	-----	9.50	0.53	-----	-----	-----	-----	1.00
* 19513.60	-----	-----	-----	-----	9.50	2.21	-----	-----	-----	-----	1.00
21952.80	-----	-----	-----	-----	9.50	0.72	-----	-----	-----	-----	1.00
24392.00	-----	-----	-----	-----	9.50	2.47	-----	-----	-----	-----	1.00

Note :

- The measurement was searched to 10th harmonic, Remark “---” means that the emissions level is too low to be measured.
- AF: Antenna Factor, Cable: Cable Loss, Pre-Amp: Preamplifier gain, Filter: High Pass Filter Insertion Loss (3.5GHz)
- Spectrum analyzer setting P(Peak): RBW=1MHz, VBW=1MHz, A(Average): RBW=1MHz, VBW=10Hz
- Remark “\*” means the Restricted band.
- Dist : correction to extra plate reading to 3m specification distance 1m measurement distance = -9.5dB
- The result basic equation calculation is as follow:  
Level = Reading + AF + Cable - Preamp + Filter - Dist, Margin = Level - Limit
- The other emission levels were very low against the limit
- The test limit distance is 3M limit.
- For 802.11g mode at 6Mbps, Antenna (2).



The frequency spectrum above 1 GHz was investigated. All emissions not reported are much lower than the prescribed limits. Readings are both peak and average values.

Company	Z-Com, Inc.	Test Date	2005/04/29
Product Name	IEEE 802.11 b/g WLAN MiniPCI Card	Test By	Vincent Chen
Model Name	XG-602MB	TEMP & Humidity	32.5°C , 56%

CH6 TX				Measurement Distance at 1m Vertical polarity							
Freq. (MHz)	Reading (dBμV)	AF (dBμV)	Cable (dB)	Pre-amp (dB)	Dist (dB)	Filter (dB)	Level (dBμV/m)	Limit (dBμV/m)	Margin (dB)	Mark (P/Q/A)	Height (Meter)
2435.34	78.77	31.76	3.59	0.00	9.50	0.00	104.63	Fundamental Frequency		P	1.00
2435.34	70.05	31.76	3.59	0.00	9.50	0.00	95.91			A	1.00
* 4874.07	49.46	34.77	5.10	35.20	9.50	1.80	46.43	74	-27.57	P	1.00
* 4874.07	43.91	34.77	5.10	35.20	9.50	1.80	40.88	54	-13.12	A	1.00
* 7325.72	45.51	39.77	6.80	35.63	9.50	2.00	48.95	74	-25.05	P	1.00
* 7325.72	34.50	39.77	6.80	35.63	9.50	2.00	37.94	54	-16.06	A	1.00
9748.10	48.08	38.53	8.33	36.60	9.50	0.55	49.39	74	-24.61	P	1.00
9748.10	41.61	38.53	8.33	36.60	9.50	0.55	42.92	54	-11.08	A	1.00
* 12176.70	-----	-----	-----	-----	9.50	0.80	-----	-----	-----	-----	1.00
14612.04	-----	-----	-----	-----	9.50	0.61	-----	-----	-----	-----	1.00
17047.38	-----	-----	-----	-----	9.50	0.52	-----	-----	-----	-----	1.00
* 19482.72	-----	-----	-----	-----	9.50	2.18	-----	-----	-----	-----	1.00
21918.06	-----	-----	-----	-----	9.50	0.73	-----	-----	-----	-----	1.00
24353.40	-----	-----	-----	-----	9.50	2.53	-----	-----	-----	-----	1.00

Note :

- The measurement was searched to 10th harmonic, Remark “---” means that the emissions level is too low to be measured.
- AF: Antenna Factor, Cable: Cable Loss, Pre-Amp: Preamplifier gain, Filter: High Pass Filter Insertion Loss (3.5GHz)
- Spectrum analyzer setting P(Peak): RBW=1MHz, VBW=1MHz, A(Average): RBW=1MHz, VBW=10Hz
- Remark “\*” means the Restricted band.
- Dist : correction to extra plate reading to 3m specification distance 1m measurement distance = -9.5dB
- The result basic equation calculation is as follow:  
Level = Reading + AF + Cable - Preamp + Filter - Dist, Margin = Level - Limit
- The other emission levels were very low against the limit
- The test limit distance is 3M limit.
- For 802.11g mode at 6Mbps, Antenna (2).



The frequency spectrum above 1 GHz was investigated. All emissions not reported are much lower than the prescribed limits. Readings are both peak and average values.

Company	Z-Com, Inc.	Test Date	2005/04/29
Product Name	IEEE 802.11 b/g WLAN MiniPCI Card	Test By	Vincent Chen
Model Name	XG-602MB	TEMP & Humidity	32.5°C , 56%

CH11 TX				Measurement Distance at 1m Horizontal polarity							
Freq. (MHz)	Reading (dBμV)	AF (dBμV)	Cable (dB)	Pre-amp (dB)	Dist (dB)	Filter (dB)	Level (dBμV/m)	Limit (dBμV/m)	Margin (dB)	Mark (P/Q/A)	Height (Meter)
2456.53	72.84	31.74	3.60	0.00	9.50	0.00	98.68	Fundamental Frequency		P	1.00
2456.53	64.15	31.74	3.60	0.00	9.50	0.00	89.99			A	1.00
* 2483.60	35.06	31.72	3.61	0.00	9.50	0.00	60.89	74	-13.11	P	1.00
* 2483.60	20.52	31.72	3.61	0.00	9.50	0.00	46.35	54	-7.65	A	1.00
* 4923.95	48.08	35.10	5.12	35.24	9.50	1.60	45.16	74	-28.84	P	1.00
* 4923.95	41.08	35.10	5.12	35.24	9.50	1.60	38.16	54	-15.84	A	1.00
* 7386.02	45.51	39.75	6.84	35.62	9.50	2.00	48.98	74	-25.02	P	1.00
* 7386.02	34.81	39.75	6.84	35.62	9.50	2.00	38.28	54	-15.72	A	1.00
9847.78	46.24	38.52	8.37	36.76	9.50	0.49	47.36	74	-26.64	P	1.00
9847.78	37.62	38.52	8.37	36.76	9.50	0.49	38.74	54	-15.26	A	1.00
* 12282.65	-----	-----	-----	-----	9.50	0.80	-----	-----	-----	-----	1.00
14739.18	-----	-----	-----	-----	9.50	0.51	-----	-----	-----	-----	1.00
17195.71	-----	-----	-----	-----	9.50	0.58	-----	-----	-----	-----	1.00
* 19652.24	-----	-----	-----	-----	9.50	2.35	-----	-----	-----	-----	1.00
* 22108.77	-----	-----	-----	-----	9.50	0.70	-----	-----	-----	-----	1.00
24565.30	-----	-----	-----	-----	9.50	2.21	-----	-----	-----	-----	1.00

Note :

- The measurement was searched to 10th harmonic, Remark "---" means that the emissions level is too low to be measured.
- AF: Antenna Factor, Cable: Cable Loss, Pre-Amp: Preamplifier gain, Filter: High Pass Filter Insertion Loss (3.5GHz)
- Spectrum analyzer setting P(Peak): RBW=1MHz, VBW=1MHz, A(Average): RBW=1MHz, VBW=10Hz
- Remark "\*" means the Restricted band.
- Dist : correction to extra plate reading to 3m specification distance 1m measurement distance = -9.5dB
- The result basic equation calculation is as follow:  
Level = Reading + AF + Cable - Preamp + Filter - Dist, Margin = Level - Limit
- The other emission levels were very low against the limit
- The test limit distance is 3M limit.
- For 802.11g mode at 6Mbps, Antenna (2).



The frequency spectrum above 1 GHz was investigated. All emissions not reported are much lower than the prescribed limits. Readings are both peak and average values.

Company	Z-Com, Inc.	Test Date	2005/04/29
Product Name	IEEE 802.11 b/g WLAN MiniPCI Card	Test By	Vincent Chen
Model Name	XG-602MB	TEMP & Humidity	32.5°C , 56%

CH11 TX				Measurement Distance at 1m Vertical polarity							
Freq. (MHz)	Reading (dBμV)	AF (dBμV)	Cable (dB)	Pre-amp (dB)	Dist (dB)	Filter (dB)	Level (dBμV/m)	Limit (dBμV/m)	Margin (dB)	Mark (P/Q/A)	Height (Meter)
2456.53	77.13	31.74	3.60	0.00	9.50	0.00	102.97	Fundamental Frequency		P	1.00
2456.53	68.49	31.74	3.60	0.00	9.50	0.00	94.33			A	1.00
* 2483.60	40.62	31.72	3.61	0.00	9.50	0.00	66.45	74	-7.55	P	1.00
* 2483.60	26.04	31.72	3.61	0.00	9.50	0.00	51.87	54	-2.13	A	1.00
* 4923.94	53.65	35.10	5.12	35.24	9.50	1.60	50.73	74	-23.27	P	1.00
* 4923.94	45.30	35.10	5.12	35.24	9.50	1.60	42.38	54	-11.62	A	1.00
* 7388.10	50.74	39.74	6.84	35.62	9.50	2.00	54.21	74	-19.79	P	1.00
* 7388.10	38.08	39.74	6.84	35.62	9.50	2.00	41.55	54	-12.45	A	1.00
9847.93	49.02	38.52	8.37	36.76	9.50	0.49	50.14	74	-23.86	P	1.00
9847.93	43.02	38.52	8.37	36.76	9.50	0.49	44.14	54	-9.86	A	1.00
* 12282.65	-----	-----	-----	-----	9.50	0.80	-----	-----	-----	-----	1.00
14739.18	-----	-----	-----	-----	9.50	0.51	-----	-----	-----	-----	1.00
17195.71	-----	-----	-----	-----	9.50	0.58	-----	-----	-----	-----	1.00
* 19652.24	-----	-----	-----	-----	9.50	2.35	-----	-----	-----	-----	1.00
* 22108.77	-----	-----	-----	-----	9.50	0.70	-----	-----	-----	-----	1.00
24565.30	-----	-----	-----	-----	9.50	2.21	-----	-----	-----	-----	1.00

Note :

- The measurement was searched to 10<sup>th</sup> harmonic, Remark “---” means that the emissions level is too low to be measured.
- AF: Antenna Factor, Cable: Cable Loss, Pre-Amp: Preamplifier gain, Filter: High Pass Filter Insertion Loss (3.5GHz)
- Spectrum analyzer setting P(Peak): RBW=1MHz, VBW=1MHz, A(Average): RBW=1MHz, VBW=10Hz
- Remark “\*” means the Restricted band.
- Dist : correction to extra plate reading to 3m specification distance 1m measurement distance = -9.5dB
- The result basic equation calculation is as follow:  
Level = Reading + AF + Cable – Preamp + Filter – Dist, Margin = Level – Limit
- The other emission levels were very low against the limit
- The test limit distance is 3M limit.
- The test data marked in gray background means the EUT emission data is located in the margin uncertainty range of emission limits.
- For 802.11g mode at 6Mbps, Antenna (2).

### 3.7 Photos of Open Site

For Antenna (1) :



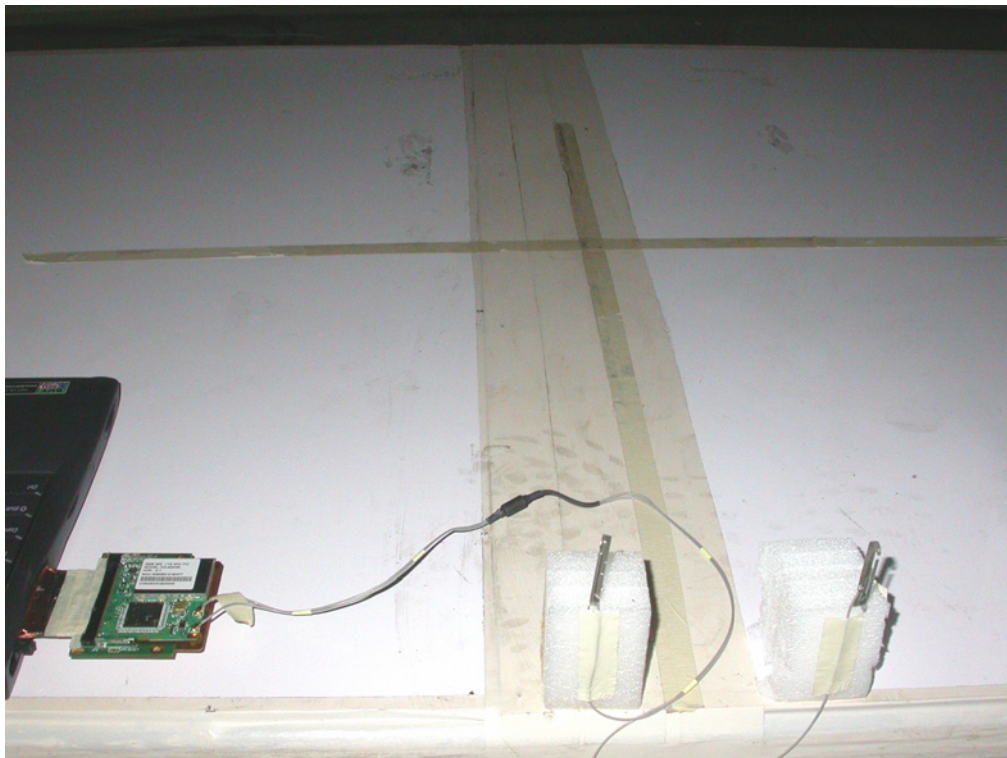

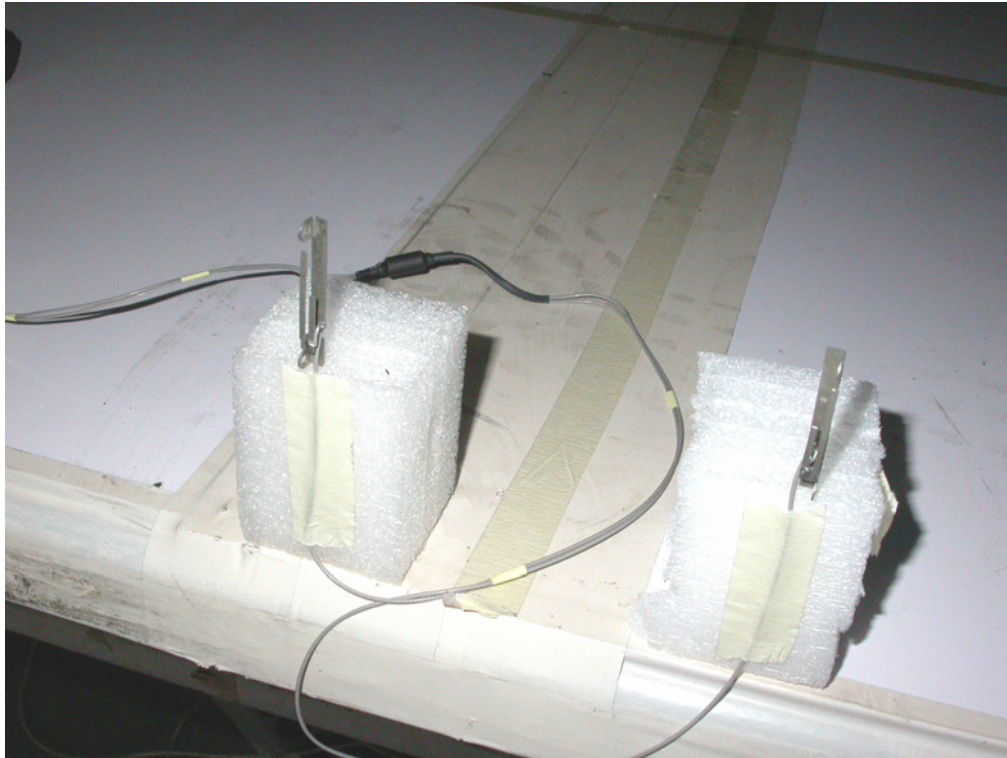



**For Antenna (2) :**

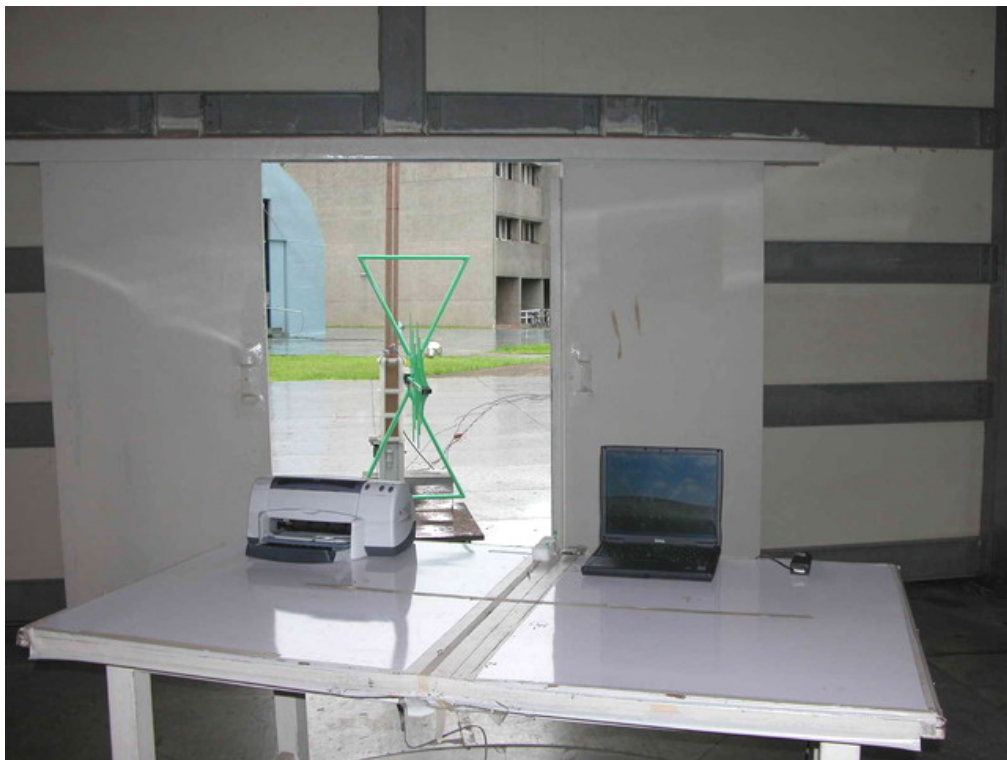

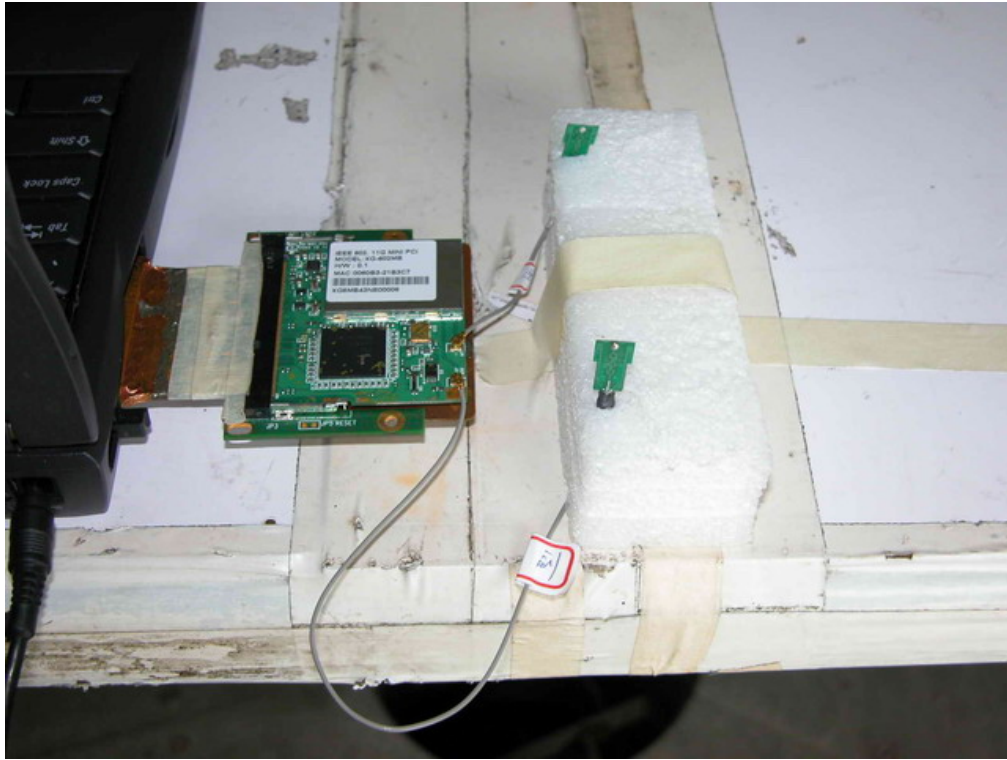



## 4. 6dB BANDWIDTH MEASUREMENT

### 4.1 Test Equipments

Description & Manufacturer	Model No.	Serial No.	Date Of Calibration
ROHDE & SCHWARZ SPECTRUM ANALYZER	FSEK30	835253/002	June 17, 2004

Note :

1. The measurement uncertainty is less than +/- 2.6dB, which is calculated as per the NAMAS document NIS81.
2. The calibration interval of the above test instruments is 12 months and the calibrations are traceable to NML/ROC and NIST/USA.

### 4.2 Test Setup

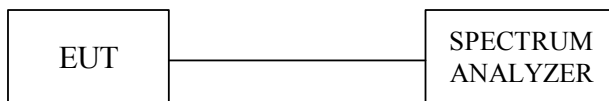

### 4.3 Limits of 6dB Bandwidth Measurement

The minimum of 6dB Bandwidth Measurement is >500KHz

### 4.4 Test Procedure

The transmitter output was connected to the spectrum analyzer through an attenuator. The bandwidth of the fundamental frequency was measured by spectrum analyzer with 100 KHz RBW and 1MHz VBW. The 6dB bandwidth is defined as the total spectrum the power of which is higher than peak power minus 6dB.

### 4.5 Uncertainty of Conducted Emission

The uncertainty of conducted emission is  $\pm 200$ KHz.

**4.6 Test Results**

<b>Input Power (System)</b>	3.3VDC (From Notebook)	<b>Environmental Conditions</b>	30°C, 60%RH
<b>Tested By</b>	Vincent Chen		

<b>Channel</b>	<b>Channel Frequency (MHz)</b>	<b>6dB Bandwidth (MHz)</b>	<b>Minimum Limit (MHz)</b>	<b>Pass / Fail</b>
1	2412	10.18	0.5	PASS
6	2437	10.14	0.5	PASS
11	2462	10.14	0.5	PASS

Note : For 802.11b Mode

<b>Channel</b>	<b>Channel Frequency (MHz)</b>	<b>6dB Bandwidth (MHz)</b>	<b>Minimum Limit (MHz)</b>	<b>Pass / Fail</b>
1	2412	16.47	0.5	PASS
6	2437	16.51	0.5	PASS
11	2462	16.51	0.5	PASS

Note : For 802.11g Mode



### 4.7 Photo of 6db Bandwidth Measurement

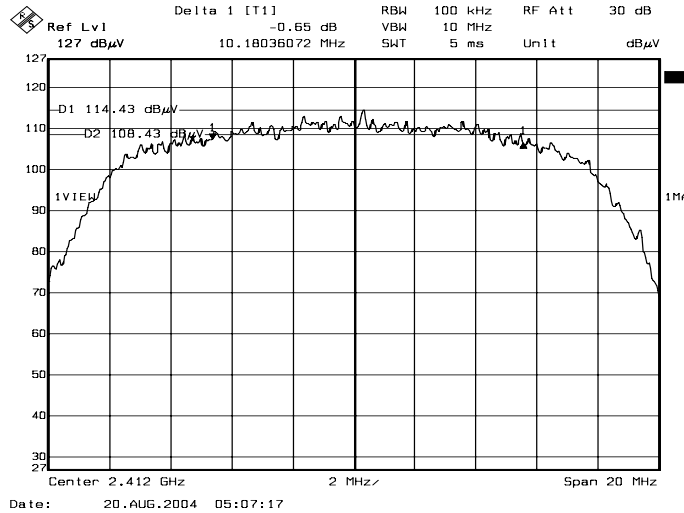

Channel 1

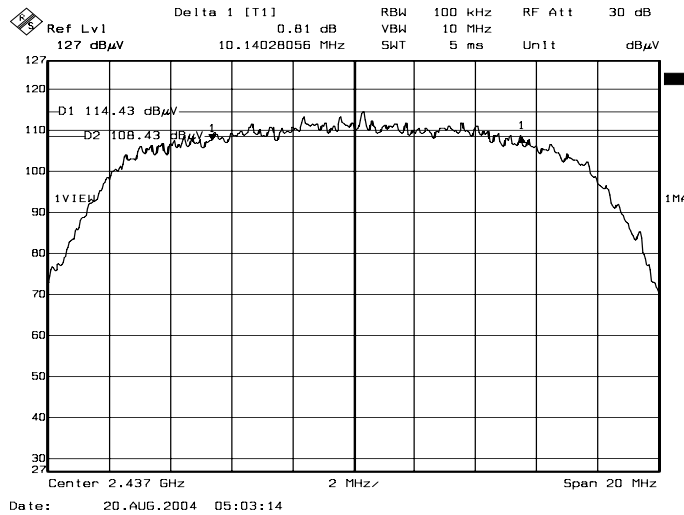

Channel 6

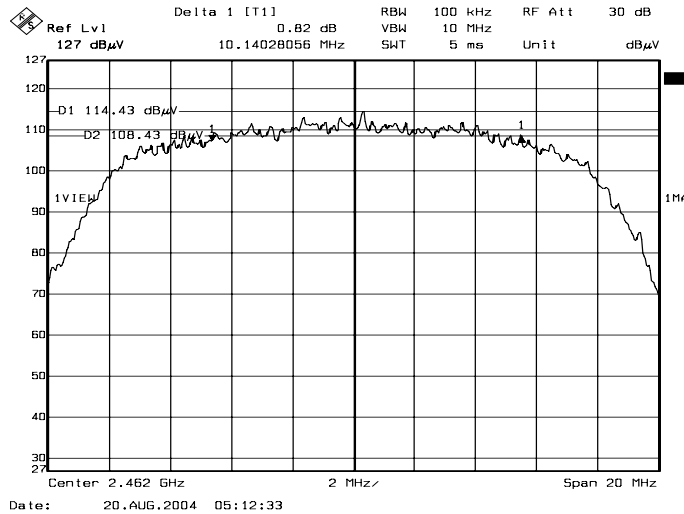

Channel 11

Note: For 802.11b Mode

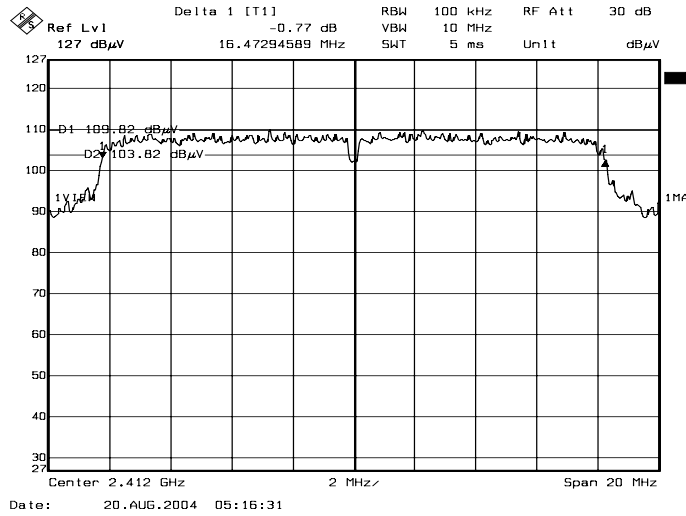

### Channel 1

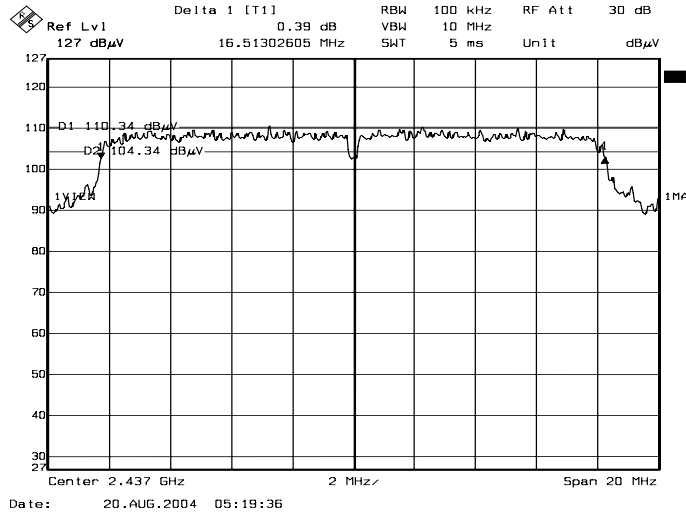

### Channel 6

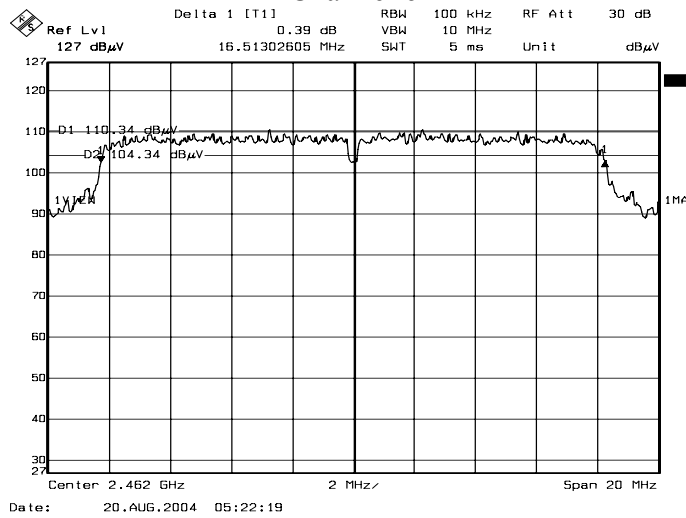

### Channel 11

Note: For 802.11g Mode



## 5. MAXIMUM PEAK OUTPUT POWER

### 5.1 Test Equipments

Description & Manufacturer	Model No.	Serial No.	Date Of Calibration
ROHDE & SCHWARZ SPECTRUM ANALYZER	FSEK30	835253/002	June 17, 2004
Agilent ATTENUATOR	8491B	57321	CAL. ON USE
ANRITSU	ML2487A MAL2491A	6K00001783 030982	February 10, 2005

Note :

1. The measurement uncertainty is less than +/- 2.6dB, which is calculated as per the NAMAS document NIS81.
2. The calibration interval of the above test instruments is 12 months and the calibrations are traceable to NML/ROC and NIST/USA.

### 5.2 Test Setup

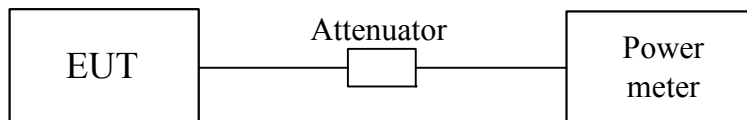

### 5.3 Limits of Maximum Peak Output Power

The Maximum Peak Output Power Measurement is 30dBm.



## 5.4 Test Procedure

The RF power output was measured with a Power meter connected to the RF Antenna connector ( conducted measurement ) while EUT was operating in transmit mode at the appropriate center frequency.

## 5.5 Uncertainty of Conducted Emission

The uncertainty of conducted emission is  $\pm 1.82\text{dB}$ .

## 5.6 Test Results

<b>Input Power (System)</b>	3.3VDC (From Notebook)	<b>Environmental Conditions</b>	30°C, 60%RH
<b>Tested By</b>	Vincent Chen		

Channel	Channel Frequency (MHz)	Average Power Output (dBm)	Peak Power Output (dBm)	Peak Power Limit (dBm)	Pass / Fail
1	2412	16.99	19.14	30	PASS
6	2437	17.07	19.23	30	PASS
11	2462	17.04	19.20	30	PASS

Note :

1. For 802.11b mode.
2. At final test to get the worst-case emission at 11Mbps.
3. Cable loss = 0.5dB, Attenuator = 10dB.
4. The results are calculated as the following equation :  
Peak Power Output = Peak Power Reading + Cable loss

Channel	Channel Frequency (MHz)	Average Power Output (dBm)	Peak Power Output (dBm)	Peak Power Limit (dBm)	Pass / Fail
1	2412	16.39	19.79	30	PASS
6	2437	16.54	20.17	30	PASS
11	2462	16.83	20.09	30	PASS

Note :

1. For 802.11g mode.
2. At final test to get the worst-case emission at 6Mbps.
3. Cable loss = 0.5dB, Attenuator = 10dB.
4. The results are calculated as the following equation :  
Peak Power Output = Peak Power Reading + Cable loss





## 6. POWER SPECTRAL DENSITY MEASUREMENT

### 6.1 Test Equipments

Description & Manufacturer	Model No.	Serial No.	Date Of Calibration
ROHDE & SCHWARZ SPECTRUM ANALYZER	FSEK30	835253/002	June 17, 2004

Note :

1. The measurement uncertainty is less than +/- 2.6dB, which is calculated as per the NAMAS document NIS81.
2. The calibration interval of the above test instruments is 12 months and the calibrations are traceable to NML/ROC and NIST/USA.

### 6.2 Test Setup

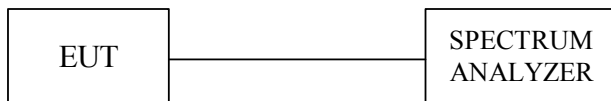

### 6.3 Limits of Power Spectral Density Measurement

The Maximum Power Spectral Density Measurement is 8dBm/3KHz.



### 6.4 Test Procedure

The transmitter output was connected to the spectrum analyzer through an attenuator, the bandwidth of the fundamental frequency was measured with the spectrum analyzer using 3KHz RBW and 30KHz VBW, set sweep time=span / 3KHz.

The power spectral density was measured and recorded.

The sweep time is allowed to be longer than span / 3KHz for a full response of the mixer in the spectrum analyzer.

### 6.5 Uncertainty of Conducted Emission

The uncertainty of conducted emission is  $\pm 1.82$ dB.

### 6.6 Test Results

<b>Input Power (System)</b>	3.3VDC (From Notebook)	<b>Environmental Conditions</b>	30°C, 60%RH
<b>Tested By</b>	Vincent Chen		

Channel	Channel Frequency (MHz)	Final RF Power Level in 3KHz BW (dBm)	Maxmum Limit (dBm)	Pass / Fail
1	2412	-7.36	8	PASS
6	2437	-7.33	8	PASS
11	2462	-7.32	8	PASS

Note : For 11Mbps (802.11b mode) at finial test to get the worst-case emission at 11Mbps.

Channel	Channel Frequency (MHz)	Final RF Power Level in 3KHz BW (dBm)	Maxmum Limit (dBm)	Pass / Fail
1	2412	-12.28	8	PASS
6	2437	-11.75	8	PASS
11	2462	-11.57	8	PASS

Note : For 54Mbps (802.11g mode) at finial test to get the worst-case emission at 6Mbps.



### 6.7 Photo of Power Spectral Density Measurement

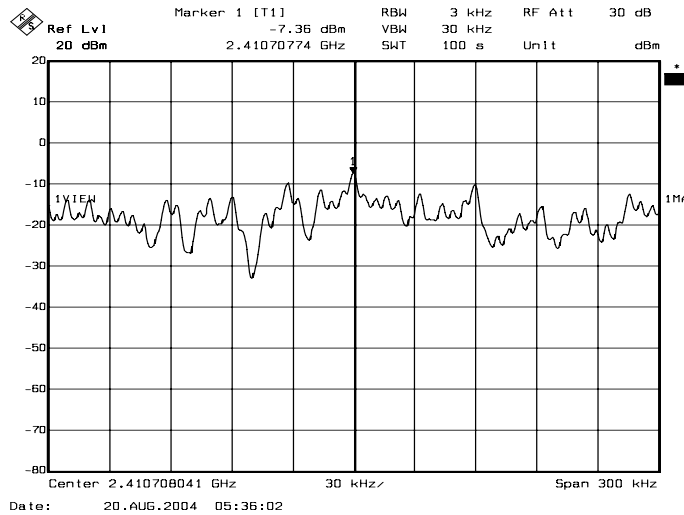

Channel 1

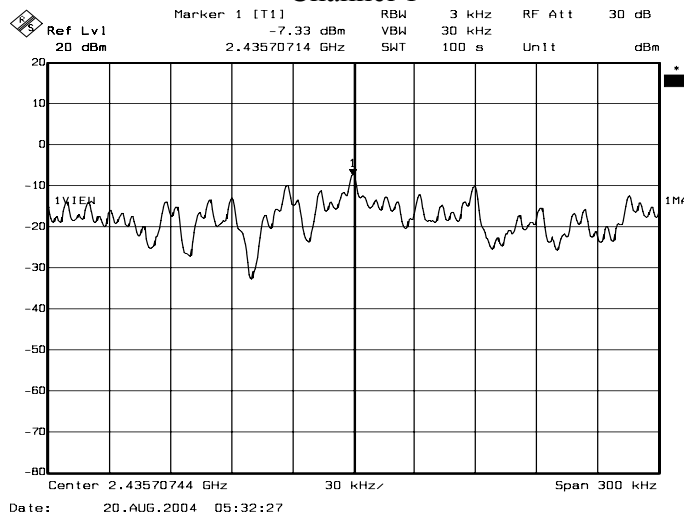

Channel 6

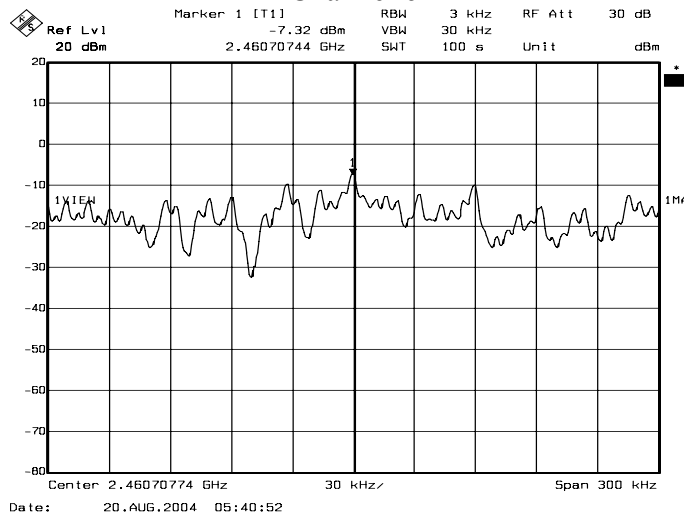

Channel 11

Note: For 802.11b Mode

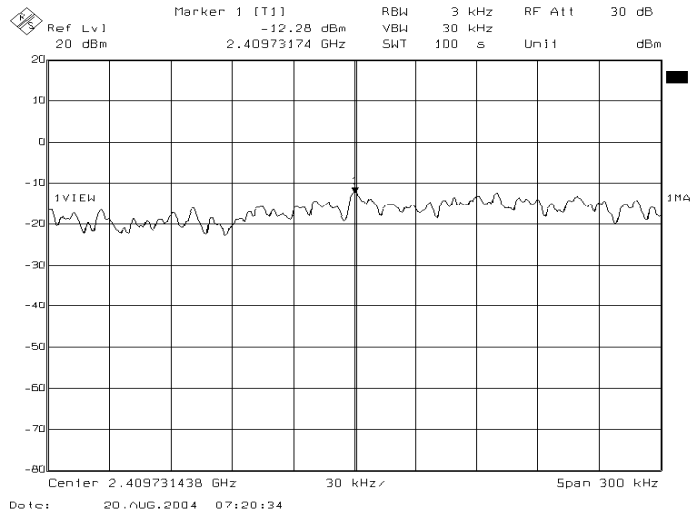

### Channel 1

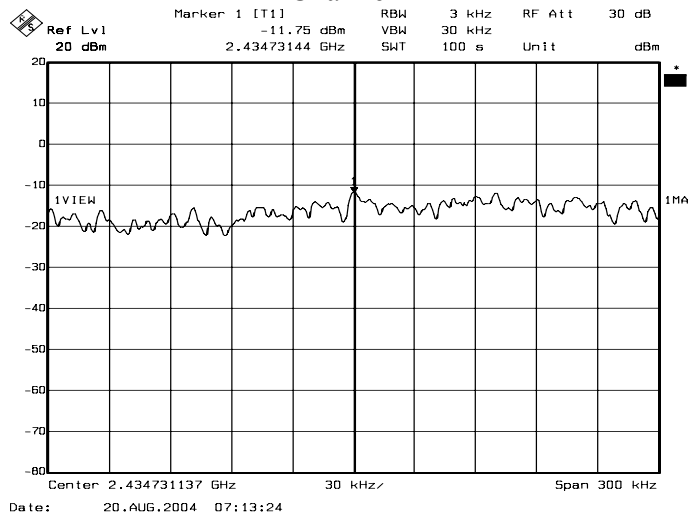

### Channel 6

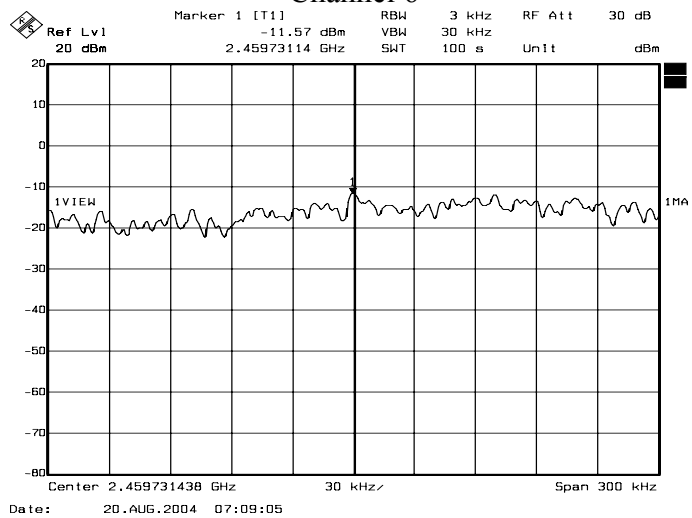

### Channel 11

Note: For 802.11g Mode



## 7. BAND EDGE MEASUREMENT

### 7.1 Test Equipments

Description & Manufacturer	Model No.	Serial No.	Date Of Calibration
ROHDE & SCHWARZ SPECTRUM ANALYZER	FSEK30	835253/002	June 17, 2004

Note :

1. The measurement uncertainty is less than +/- 2.6dB, which is calculated as per the NAMAS document NIS81.
2. The calibration interval of the above test instruments is 12 months and the calibrations are traceable to NML/ROC and NIST/USA.

### 7.2 Test Setup

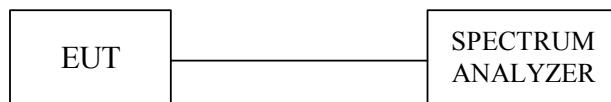

### 7.3 Limits of Band Edge Emissions Measurement

1. Below -20dB of the highest emission level in operating band.
2. Fall in the restricted bands listed in section 15.205. The maximum permitted average field strength is listed in section 15.209.

### 7.4 Test Procedure

The transmitter output was connected to the spectrum analyzer via a low lose cable. Set both RBW and VBW of spectrum analyzer with suitable frequency span including 100KHz bandwidth from band edge. The band edges was measured and recorded.

### 7.5 Uncertainty of Conducted Emission

The uncertainty of conducted emission is  $\pm 1.82$ dB.



## 7.6 Test Results

### A. Conducted

Refer to 7.7 photo of out band Emission measurement

### B. Radiated

<b>Input Power (System)</b>	3.3VDC (From Notebook)	<b>Environmental Conditions</b>	30°C, 60%RH
<b>Tested By</b>	Vincent Chen		

For 802.11b mode, Antenna (1)

Refer to the section 3.6, the measured radiated band edge emissions are listed below :

Band edge Frequency (MHz)		Measured radiated band edge field strength (dBuV/m)		Radiated band edge field strength limit (dBuV/m)		Test result
		Horizontal	Vertical	Horizontal	Vertical	
2399.90	PK	65.18	69.48	85.89	89.72	PASS
	AV	56.88	61.08	79.26	86.72	
2483.50	PK	50.63	54.43	74.00	74.00	PASS
	AV	36.83	39.93	54.00	54.00	

For 802.11g mode, Antenna (1)

Refer to the section 3.6, the measured radiated band edge emissions are listed below :

Band edge Frequency (MHz)		Measured radiated band edge field strength (dBuV/m)		Radiated band edge field strength limit (dBuV/m)		Test result
		Horizontal	Vertical	Horizontal	Vertical	
2399.90	PK	72.88	79.38	80.14	85.57	PASS
	AV	62.38	68.88	71.82	77.29	
2483.50	PK	60.93	64.03	74.00	74.00	PASS
	AV	48.13	51.03	54.00	54.00	

Note : Radiated band edge field strength is measured according to measurement procedure ANSI C63.4-2001.



<b>Input Power (System)</b>	3.3VDC (From Notebook)	<b>Environmental Conditions</b>	32.5°C, 56%RH
<b>Tested By</b>	Vincent Chen		

For 802.11b mode, Antenna (2)

Refer to the section 3.6, the measured radiated band edge emissions are listed below :

Band edge Frequency (MHz)		Measured radiated band edge field strength (dBuV/m)		Radiated band edge field strength limit (dBuV/m)		Test result
		Horizontal	Vertical	Horizontal	Vertical	
2399.90	PK	64.99	69.10	81.24	85.35	PASS
	AV	57.27	61.41	74.36	83.59	
2483.50	PK	45.12	50.66	74.00	74.00	PASS
	AV	33.58	39.04	54.00	54.00	

For 802.11g mode, Antenna (2)

Refer to the section 3.6, the measured radiated band edge emissions are listed below :

Band edge Frequency (MHz)		Measured radiated band edge field strength (dBuV/m)		Radiated band edge field strength limit (dBuV/m)		Test result
		Horizontal	Vertical	Horizontal	Vertical	
2399.90	PK	76.03	78.89	80.03	82.89	PASS
	AV	65.27	68.20	71.14	74.07	
2483.50	PK	62.38	66.67	74.00	74.00	PASS
	AV	48.60	52.94	54.00	54.00	

Note : Radiated band edge field strength is measured according to measurement procedure ANSI C63.4-2001.



### 7.7 Photo of Band edge Measurement

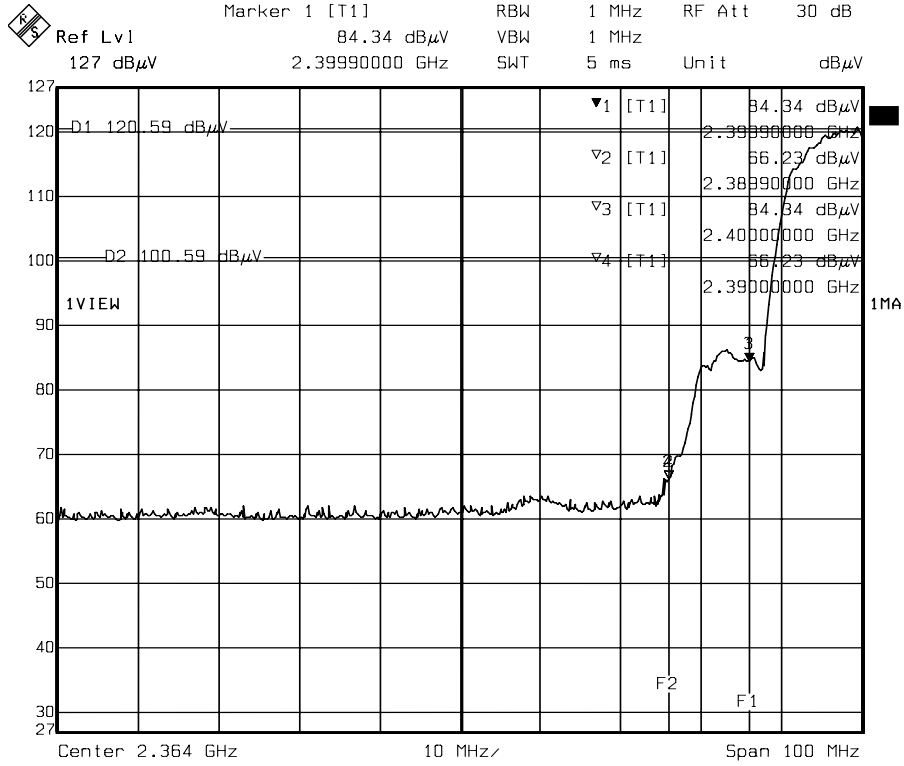

Lower Band edge (Peak)

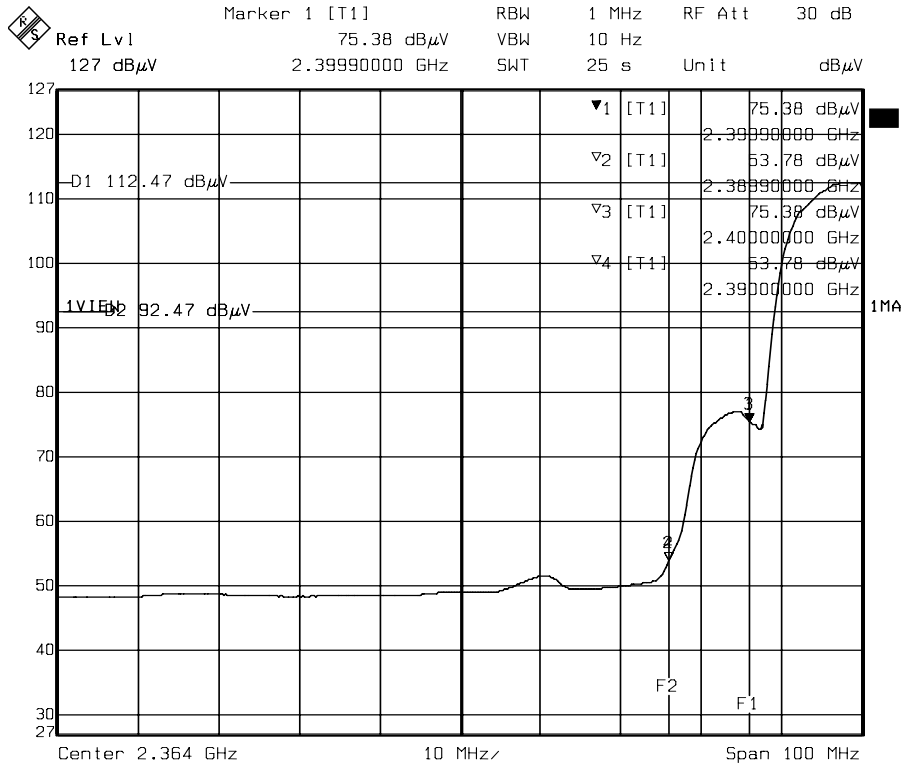

Lower Band edge (Average)

Note: For 802.11b Mode



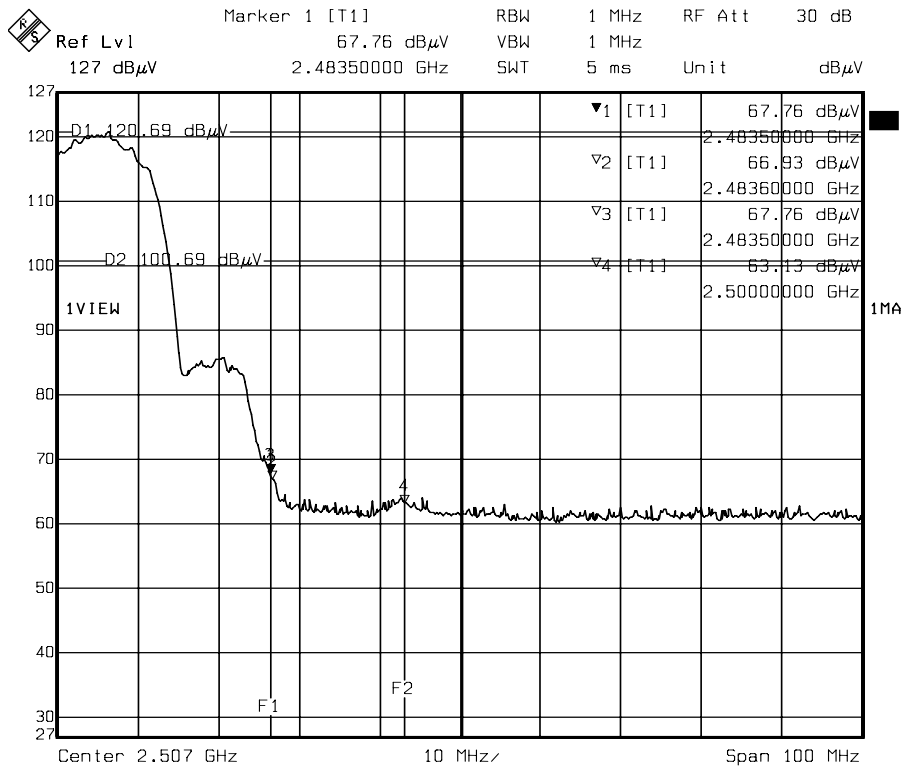

Date: 20.AUG.2004 07:43:45

### Higher Band edge (Peak)

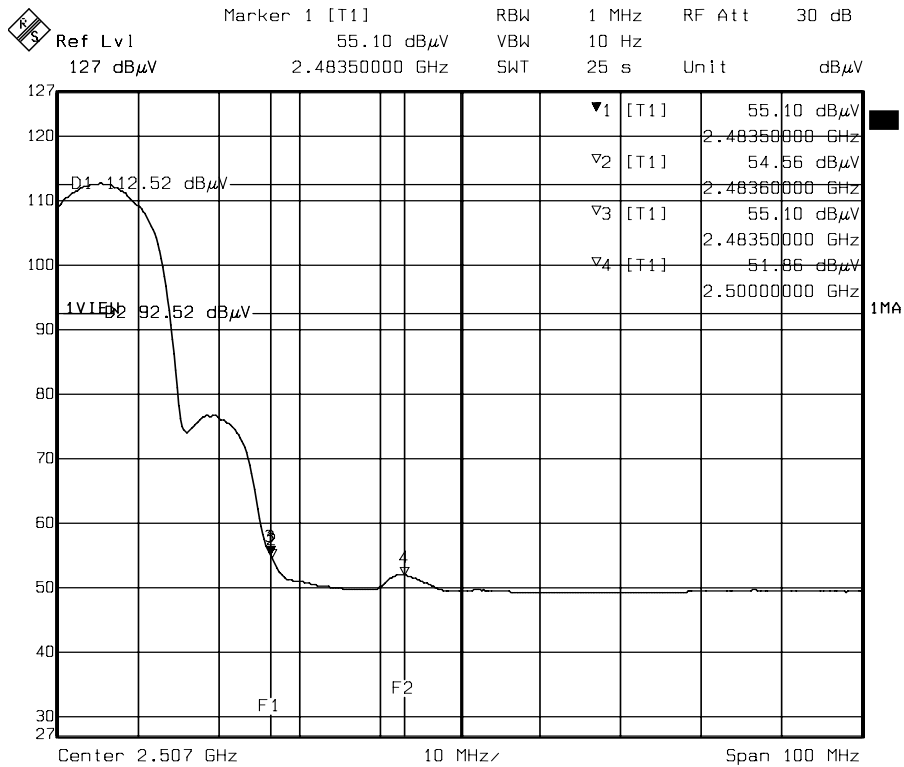

Date: 20.AUG.2004 07:47:02

### Higher Band edge (Average)

Note: For 802.11b Mode

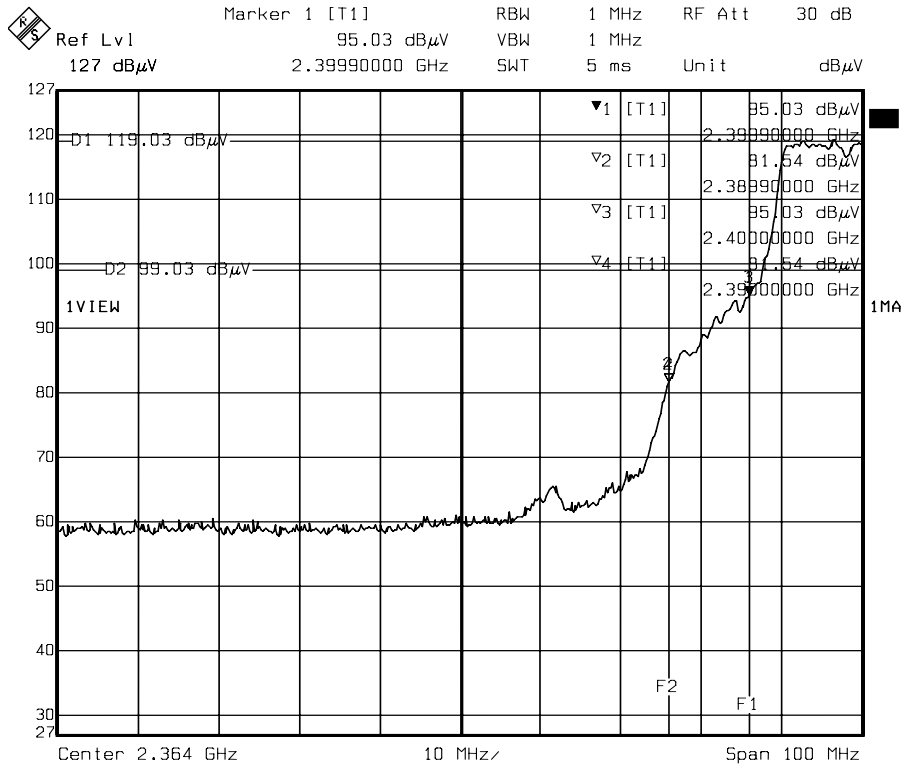

Date: 20.AUG.2004 07:26:22

### Lower Band edge (Peak)

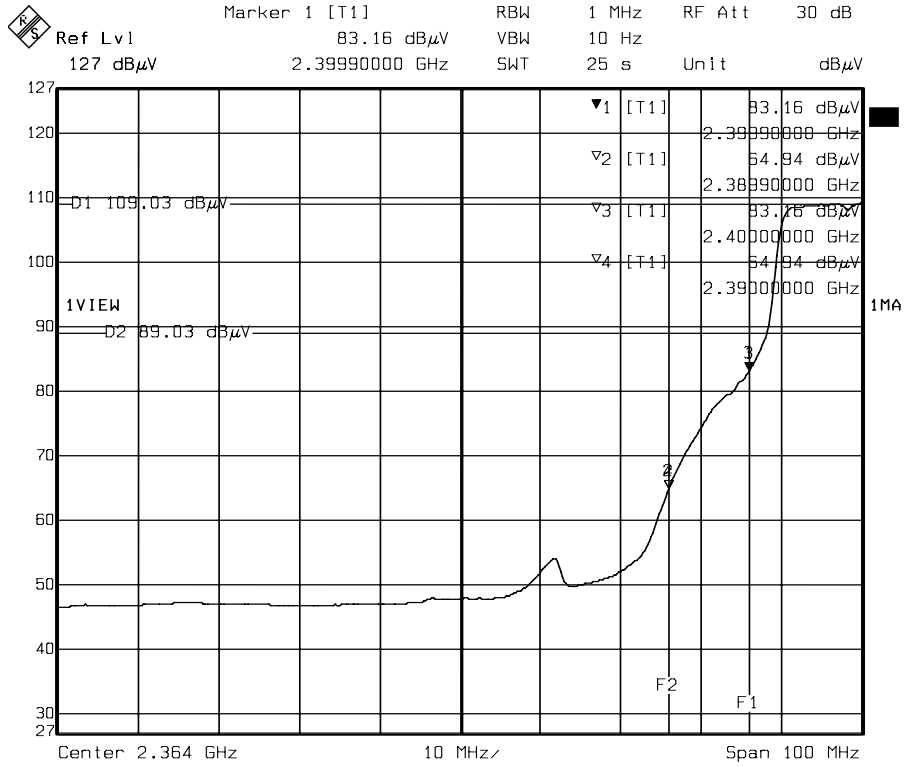

Date: 20.AUG.2004 07:29:27

### Lower Band edge (Average)

Note: For 802.11g Mode

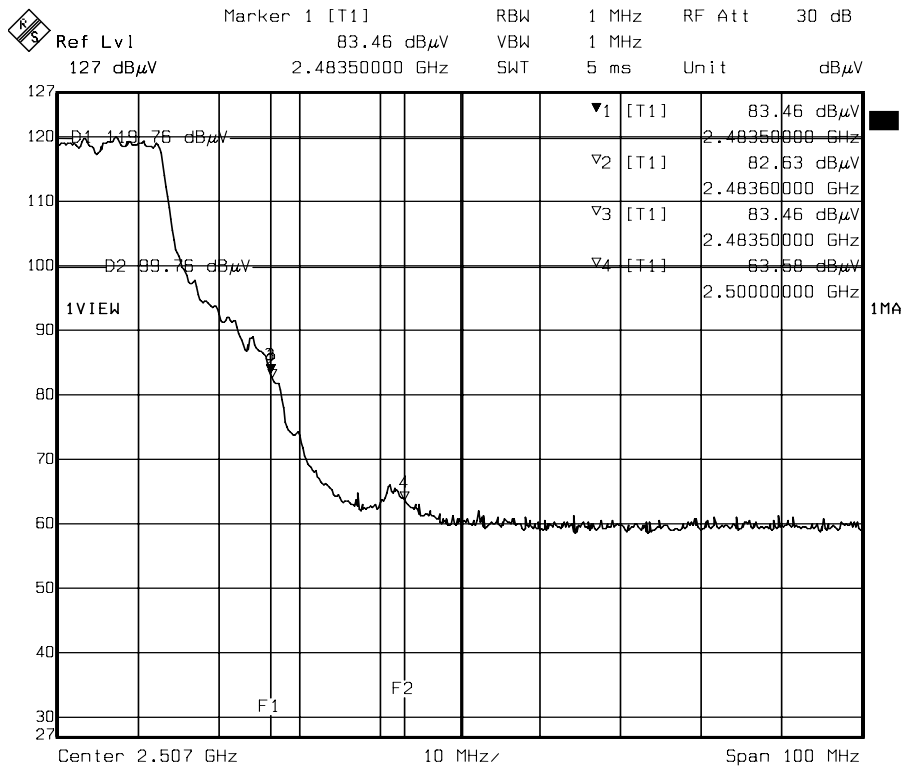

Date: 20.AUG.2004 07:39:13

### Higher Band edge (Peak)

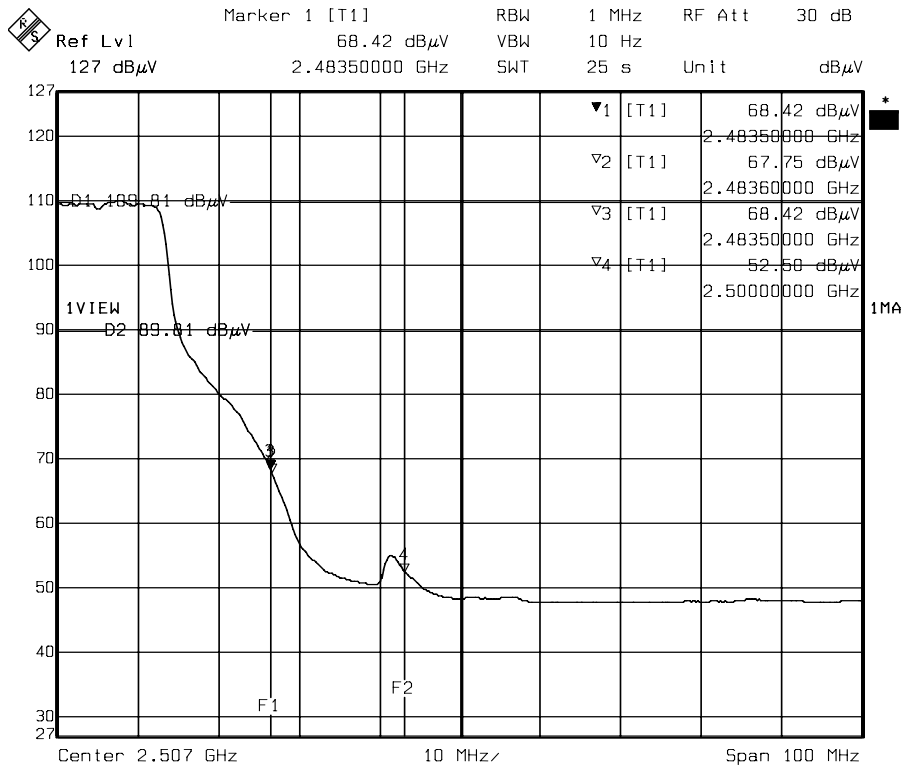

Date: 20.AUG.2004 07:35:27

### Higher Band edge (Average)

Note: For 802.11g Mode



## **8. ANTENNA REQUIREMENT**

### **8.1 Standard Applicable**

For intentional device, according to FCC 47 CFR Section 15.203, an intentional radiator shall be designed to ensure that no antenna other than that furnished by the responsible party shall be used with the device.

And according to FCC 47 CFR Section 15.247 (b), if transmitting antennas of directional gain greater than 6dBi are used, the power shall be reduced by the amount in dB that the directional gain of the antenna exceeds 6dBi.

### **8.2 Antenna Connected Construction**

The antenna used in this product is Pifa and PCB antenna. The maximum Gain of this antenna is only 3dBi and 2.8dBi.



## 9. RF EXPOSURE EVALUATION

According to FCC 1.1310 : The criteria listed in the following table shall be used to evaluate the environment impact of human exposure to radio frequency (RF) radiation as specified in 1.1307(b)

### LIMITS FOR MAXIMUM PERMISSIBLE EXPOSURE (MPE)

Frequency Range (MHz)	Electric Field Strength (V/m)	Magnetic Field Strength (A/m)	Power Density (mW/cm <sup>2</sup> )	Average Time
(A) Limits for Occupational / Control Exposures				
300-1,500	--	--	F/300	6
1,500-100,000	--	--	5	6
(B) Limits for General Population / Uncontrol Exposures				
300-1,500	--	--	F/1500	6
1,500-100,000	--	--	1	30

### 9.1 Friis Formula

Friis transmission formula :  $P_d = (P_{out} * G) / (4 * \pi * r^2)$

Where

$P_d$  = power density in mW/cm<sup>2</sup>

$P_{out}$  = output power to antenna in mW

G = gain of antenna in linear scale

$\pi$  = 3.1416

r = distance between observation point and center of the radiator in cm

$P_d$  is the limit of MPE, 1 mW/cm<sup>2</sup>. If we know the maximum gain of the antenna and the total power input to the antenna, through the calculation, we will know the distance "r" where the MPE limit is reached.

### 9.2 EUT Operating Condition

A software provided by client enabled the EUT to transmit and receive data at lowest, middle and highest channel individually.



### 9.3 Test Result of RF Exposure Evaluation

Test Item : RF Exposure Evaluation Data

Test Mode : Normal Operation

#### 9.3.1 Antenna Gain

Antenna Gain : The maximum Gain measured in fully anechoic chamber is 3dBi  
And 2.8dBi linear scale.

#### 9.3.2 Output Power into Antenna & RF Exposure Evaluation Distance

Channel	Channel Frequency (MHz)	Output Average Power to Antenna (dBm)	Antenna Gain	Power Density at 20cm (mW/cm <sup>2</sup> )	LIMITS (mW/cm <sup>2</sup> )
CH1	2412.00	16.99	3	0.019849	1
CH6	2437.00	17.07	3	0.020218	1
CH11	2462.00	17.04	3	0.020078	1

Note :

1. For 802.11b mode (11Mbps).
2. The power density Pd (4th column) at a distance of 20cm calculated from the friis transmission formula is far below the limit of 1 mW/cm<sup>2</sup> . The EUT is classified as mobile product. So, RF exposure limit warning or SAR test are not required.

Channel	Channel Frequency (MHz)	Output Average Power to Antenna (dBm)	Antenna Gain	Power Density at 20cm (mW/cm <sup>2</sup> )	LIMITS (mW/cm <sup>2</sup> )
CH1	2412.00	16.39	3	0.017287	1
CH6	2437.00	16.54	3	0.017895	1
CH11	2462.00	16.83	3	0.019131	1

Note :

1. For 802.11g mode (6Mbps).
2. The power density Pd (4th column) at a distance of 20cm calculated from the friis transmission formula is far below the limit of 1 mW/cm<sup>2</sup> . The EUT is classified as mobile product. So, RF exposure limit warning or SAR test are not required.