

The Body Control Module (BCM), which is the heart of the vehicle electrical architecture, integrates a fused electrical bus center for power distribution and a body computer in a single module. This integration concept is designed to streamline and optimize wiring and wiring connections by removing redundant power feeds, increase the sharing of fusing, and to fully utilize the capability of electronics and module foundation by including multiple functions within the same housing thereby re-using microcontroller, power supply, transient protections, housing, brackets, etc.

The BCM contains the following main parts:

**Electronic Body Function Controller** - Many of the body and light functions are controlled by the BCM.

**Switching and Fuse Block** - The BCM will handle fusing and switching of loads in the vehicle. Electromechanical relays or power MOSFETs are used for the switching.

**Electrical Junction and Distribution Block** - The BCM acts as a connection block between several cable harnesses. It is also the source of the different voltages used in the electrical distribution system, based upon Power Mode. The sequencing of voltages at start-up and shut down is controlled by the BCM.

The BCM module contains one six layer, 1oz copper, FR4 Board PCB enclosed in a single plastic housing, PCB mounted relays as well as fuse forks to interface with the Serviceable fuses and circuit breaker, Power Supply, Microcontrollers, Communication ICs, Power Drivers, and interface circuits for analog and digital inputs. All variants of the BCM share common PCB. The population of the electronics components on the PCBs is variant dependent. There is one power feed to this module. The BCM has a Logic Ground and Power Ground, which is used for the GND reference for the Door Locking H-Bridge Outputs. The module communicates with the other vehicle electronic devices via high speed CAN, 4 LIN Channels. In addition, the module controls and processes several digital and analog inputs and outputs.

The electronic and embedded control portion of the BCM controls typical body computer functions such as:

**Interior Lighting** – Courtesy Lighting, Switch Backlighting with PWM dimming, Demand Lighting.

**Exterior Lighting** – Headlamps, Turn/Hazard Lamps, Stop Lamps and CHMSL, Park Lamps, Reverse Lighting.

**Safety/Security** –Panic Alarm, Door Lock/Unlock, Anti-Theft Alarm.

**Power Door Locks** – Control for all door locks via key fob, Lock/Unlock Switches, Auto locking.

**Battery saver** – turns off power to High beam, Low beam, Park & Interior lamp and demand lighting loads after a predetermined period of time

**Delayed Accessory** – provides power to certain vehicle accessories (not limited to radio, power windows) for a prescribed period of time provided certain conditions are present.

**Driver information** – provides low brake fluid, park brake, and door ajar switch status to the instrument cluster and message center over the HS-CAN bus.

**HSCAN Serial Interface** – vehicle network communication link for diagnostics and inter-module communication.

**LIN** – There are four LIN busses – LIN\_01 is dedicated for PATS, LIN\_02 for WIPER, LIN\_03 for SIM and LIN\_04 reserved for BMS.

**Brake Shift Interlock** – activate the brake shift interlock solenoid under specified functional spec conditions.

**Ignition Switch** – Directly read the ignition switch and provides the status over the HS-CAN bus.

**Key-In Position** – Directly read the key-in switch and provide the status over the HS-CAN bus.

**Lift glass Release** – monitor lift glass release button and provide hardwired output for lift glass release.

**Diagnostics** –14229

**Operational Mode Management (OMM)** – hardware (Run/ACC relay, Run/Start relay and Run bus) and software support.

**Safety Beacon System (SBS)** – Interface to RCM via CAN to activate horn and flash the hazards.

**Wake-Up** – signal to PCM and Transmission control module relays for power upon BCM wake-up

**Immobilizer / PATS** – Recognizes valid start command and authorizes PCM to start.

**Energy Management** – Determine optimum system voltage and control input to PCM for alternator charging control.

**RF Receiver** - RKE Key fob for lock/unlock and alarm 315 Single channel & 434 MHz multichannel.

c) Product Mechanical View:

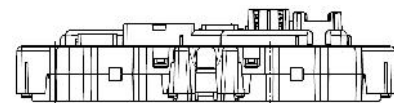
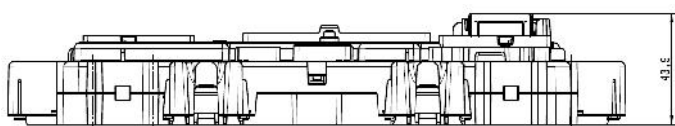
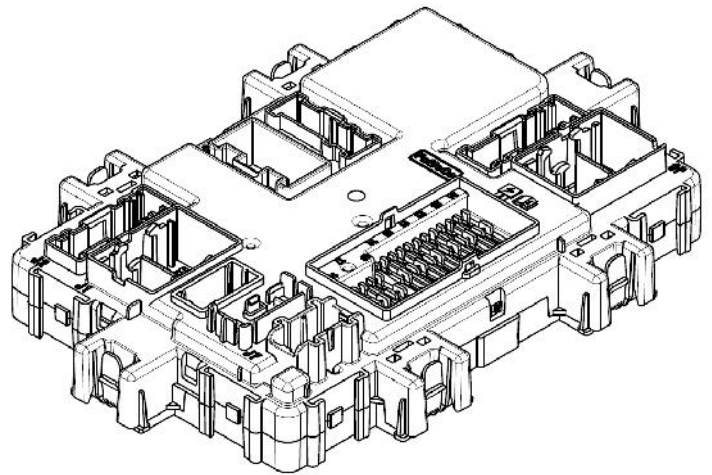
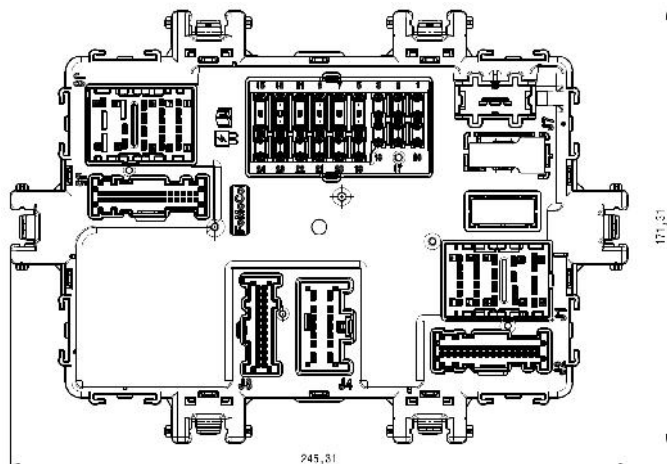

Position3

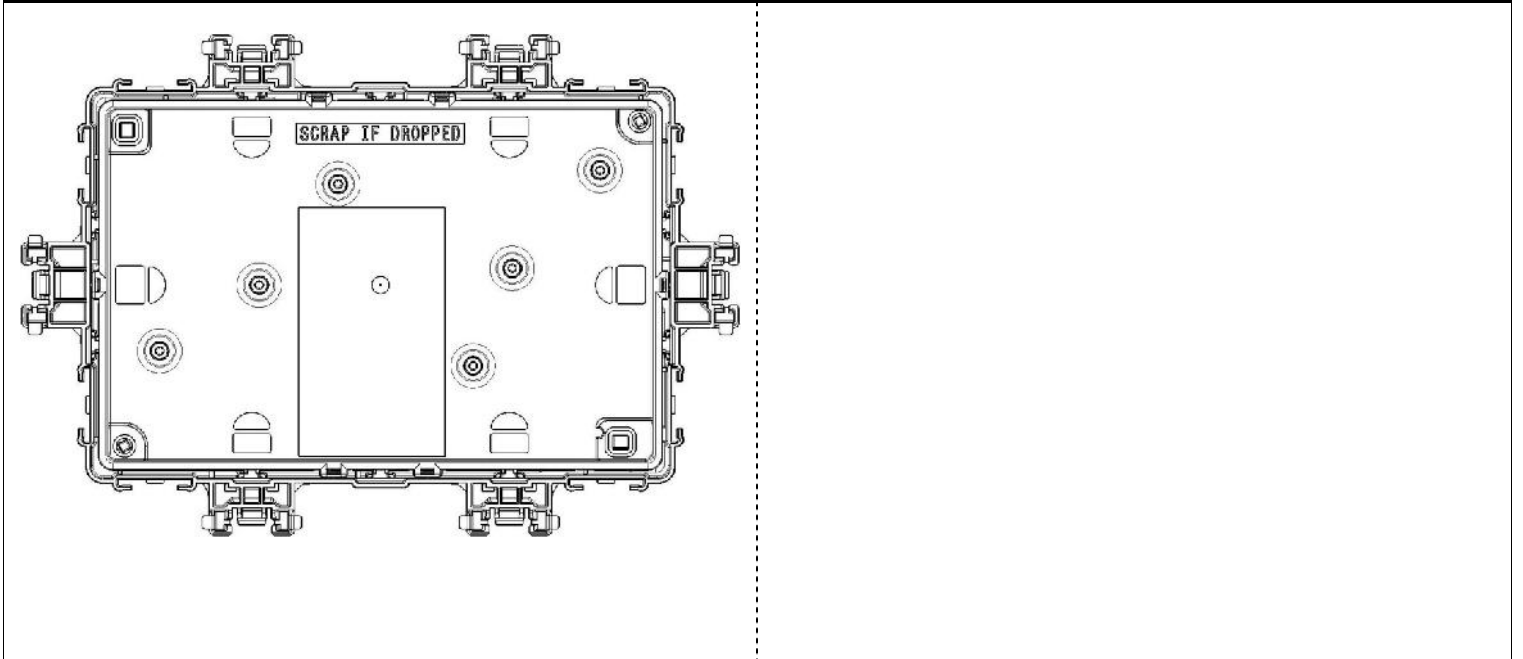

Upper housing: plastic PP GF-20. Lower housing: plastic PP-T40.