

Technical description

5WY7976

Siemens VDO

FORD PATS Clip-On

5WY7976

Homologation Support Documents

SV C BC P2 RF LF
RF Engineer

Aris Lambropoulos
Tel: (248) 764-6771
aris.lambropoulos@siemens.com

2. Module Housing

The module assembly contains a bobbin assembly, a printed circuit board assembly, and a top cover. The bobbin assembly and top cover are a glass filled nylon material, PBT -GF20. A four-pin connector and antenna ring are injection molded into the bobbin assembly. The PCB is 1 Oz. Copper, double sided, all SMD components will be affixed to the PCB by a double -sided IR reflow process. The PCB will mount to the housing via six press fit pins. The wire antenna is connected to the PCB by two of the six press fit pins. The top cover attaches to the bobbin assembly with four snaps and helps protect the wire antenna and PCB.

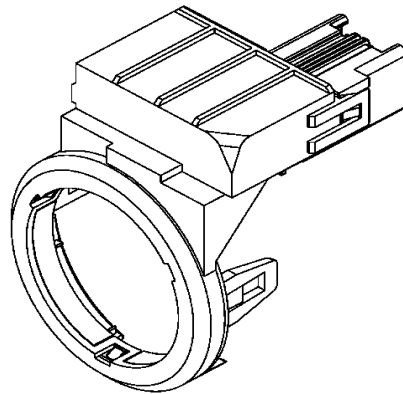
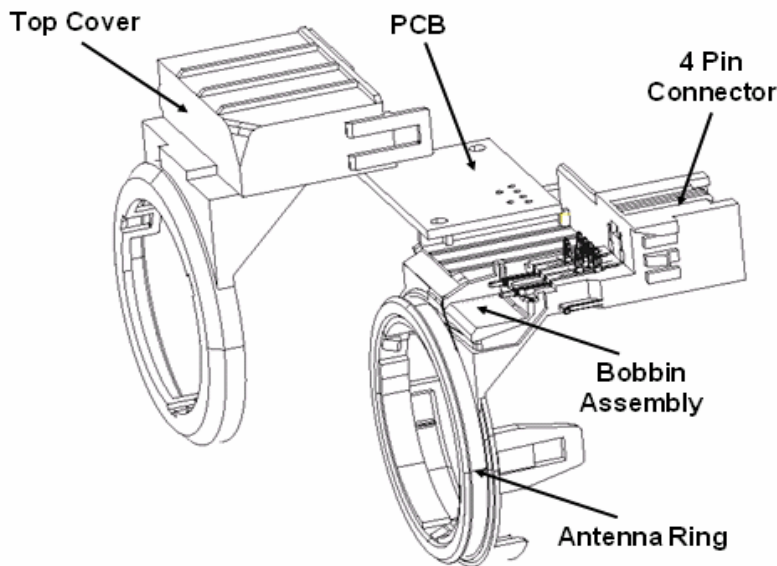

4. Interface Requirements

4.1 PATS Clip_On Connector

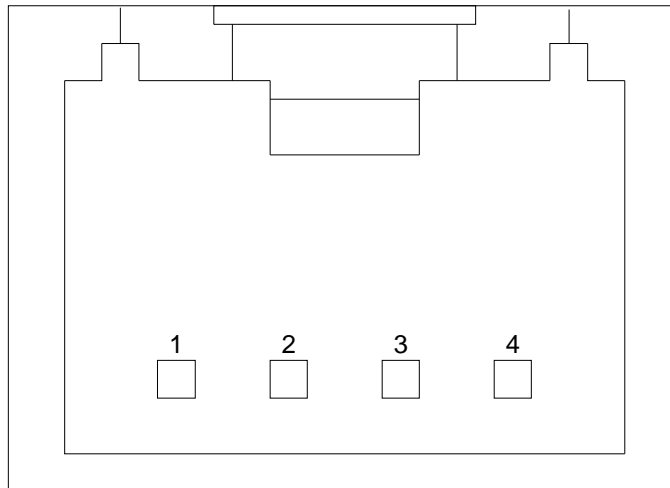

Mechanical Connector

Front View Looking Into Connector

Pin #	Pin Description	Steady State Current (Key Off)	Steady State Current (Key Run/Start)	Operating Voltage	Frequency or /MIN BIT Width	% Duty
1	Ignition	0 mA	50 mA	VBatt	DC	DC
2	Ground	0.015 mA	50 mA	0v	DC	DC
3	TX	0 mA	12 mA for 50 ms	0 – VBatt	64 μ s	VAR.
4	RX (SCI-out)	0 mA	12 mA < 1 sec.	0 – VBatt	15.625kbaud	VAR.

Table 1 Pin Description

4.2 Terminal Definitions and Characteristics

All inputs and outputs shall be capable to withstand any single point failure of a short to battery or ground, through any resistive path, without physical damage to the component while the fault is occurring, and any physical damage and/or functional degradation once the fault is removed. .

4.2.1 PATS Clip_On Permanent Battery and Ground Connections

Signal Name	Signal Function	Electrical Characteristics
Ignition	Power to the module	Min Operating Voltage: 7 V Max Operating Voltage: 24 V I _{nom} @ 12.0 V: 32mA
Ground	Ground to the module	I _{nom} @ 12.0 V: 32mA

Table 2 Battery and Ground Connection Ratings

4.2.2 PATS Clip_On Input

All digital inputs shall meet the applicable Generic Body Module SDS requirements unless otherwise agreed to by Ford Motor Company

Signal ID	Functional Name	Active (On) State	Inactive (Off) State	Min Logical High Threshold	Max. Logical Low Threshold
Tx Input	Transmit Data	Low	High (1KOhm pull up resistor)	3.97 V	3.04V

Table 3 Tx Input

¹ The given limits include a maximum GND voltage shift between SJB Logic GND and switch GND of ± 1 V.

4.2.3 PATS Clip_On Output

Signal ID	Type of Output/ Driver	Minimum functional voltage	Maximum functional voltage	Minimum performance voltage	Maximum performance voltage	Output short circuit protection
Rx Output	Low Side Driver	7V	24V	7V	24V	Provided

Table 4 Rx Output

Characteristics:

- Short circuit to ground and overload protections are provided
- Maximum Low output voltage: 0.58V
- Operating Current at Nominal Voltage (12.0V)= 12mA
- Nominal Frequency= 15.625KHz
- Minimum/Maximum Frequency= 14.843KHz/16.407 KHz

4.2.4 Serial Communication

The transceiver is to communicate transponder data to the Control function using a 15.625 kHz +/- 5% serial communications interface signal. The signal is to be in standard UART format with one start bit and one stop bit, and no parity. The signal exiting the transceiver module shall be asserted low (ground).

The serial communication will exactly mirror the transponder receive signal, except for the addition of diagnostic bytes and start and stop bits. This means that a transponder "1" signal, as specified by the appropriate transponder ES, will correspond to a UART "1" signal .

Label USA, Canada

Siemens VDO
5WY7976
FCC ID:M3M5WY7976
IC267F-5WY7976

Note Owner Manual:

This device complies with Part 15 of the FCC Rules. Operation is subject to the following two conditions:

- (1) This device may not cause harmful interference, and
- (2) this device must accept any interference received, including interference that may cause undesired operation.

Caution:

Any changes or modifications not expressly approved by the party responsible for compliance could void the user's authority to operate this equipment.

Canada:

Operation is subject to the following two conditions: (1) this device may not cause harmful interference, and (2) this device must accept any interference received, including interference that may cause undesired operation.

SV C BC P2 RF LF
RF Engineer

Aris Lambropoulos
Tel: (248) 764-6771
aris.lambropoulos@siemens.com