

Amber Helm Development L.C.

92723 Michigan Hwy-152

Sister Lakes, Michigan 49047 USA

Tel: 888-847-8027

EMC Test Report

CON1-WR1903TX

Issued: March 25, 2019

regarding

USA: CFR Title 47, Part 15.231 (Emissions)
Canada: IC RSS-210/GENe (Emissions)

for



RCKF Module

Category: Limited Modular Transmitter

Judgments:

15.231 / RSS-210v9 Compliant

Testing Completed: March 22, 2019



Prepared for:

Continental Automotive

4685 Investment Drive, Troy Michigan 48098 USA

Phone: +1 (248) 764-6783, Fax: +1 (248) 764-7281

Contact: Charles Muma, Charles.Muma@continental-corporation.com

Data Recorded by:

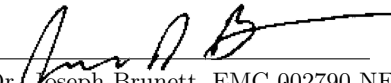
Dr. Joseph Brunett, EMC-002790-NE

Reviewed by:

Gordon Helm, EMC-002401-NE

Prepared by:

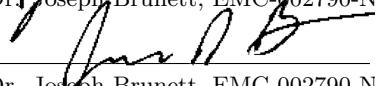
Dr. Joseph Brunett, EMC-002790-NE

Date of Issue: March 25, 2019

Revision History

Rev. No.	Date	Details	Revised By
r0	March 25, 2019	Initial Release.	J. Brunett
r1	April 11, 2019	Clarifications and Typo. Corrections	J. Brunett
r2	April 15, 2019	Typo. Corrections	J. Brunett

Contents

Revision History	2
Table of Contents	2
1 Test Report Scope and Limitations	4
1.1 Laboratory Authorization	4
1.2 Report Retention	4
1.3 Subcontracted Testing	4
1.4 Limitation of Results	4
1.5 Copyright	4
1.6 Endorsements	4
1.7 Test Location	5
1.8 Traceability and Equipment Used	5
2 Test Specifications and Procedures	6
2.1 Test Specification and General Procedures	6
3 Configuration and Identification of the Equipment Under Test	7
3.1 Description and Declarations	7
3.1.1 EUT Configuration	8
3.1.2 Modes of Operation	9
3.1.3 Variants	9
3.1.4 Test Samples	9
3.1.5 Functional Exerciser	9
3.1.6 Modifications Made	9
3.1.7 Production Intent	9
3.1.8 Declared Exemptions and Additional Product Notes	9
4 Emissions	11
4.1 General Test Procedures	11
4.1.1 Radiated Test Setup and Procedures	11
4.1.2 Conducted Emissions Test Setup and Procedures	13
4.1.3 Power Supply Variation	13
4.2 Intentional Emissions	14
4.2.1 Fundamental Emission Pulsed Operation	14
4.2.2 Fundamental Emission Bandwidth	18
4.2.3 Fundamental Emission Field Strength	21
4.3 Unintentional Emissions	24
4.3.1 Transmit Chain Spurious Emissions	24
4.3.2 Radiated Digital Spurious	32
5 Measurement Uncertainty and Accreditation Documents	33

List of Tables

1	Test Site List.	5
2	Equipment List.	5
3	EUT Declarations.	7
4	Fundamental Emission Pulsed Operation.	14
5	Fundamental Emission Bandwidth.	18
6	Fundamental Emission Field Strength.	21
6	Fundamental Emission Field Strength.	22
6	Fundamental Emission Field Strength.	23
7	Transmit Chain Spurious Emissions.	24
7	Transmit Chain Spurious Emissions.	25
7	Transmit Chain Spurious Emissions.	26
7	Transmit Chain Spurious Emissions.	27
7	Transmit Chain Spurious Emissions.	28
7	Transmit Chain Spurious Emissions.	29
7	Transmit Chain Spurious Emissions.	30
7	Transmit Chain Spurious Emissions.	31
8	Measurement Uncertainty.	33

List of Figures

1	Photos of EUT.	7
2	EUT Test Configuration Diagram.	8
3	Radiated Emissions Diagram of the EUT.	11
4	Radiated Emissions Test Setup Photograph(s).	12
5	Fundamental Emission Pulsed Operation.	15
5	Fundamental Emission Pulsed Operation.	16
5	Fundamental Emission Pulsed Operation.	17
6	Fundamental Emission Bandwidth.	19
6	Fundamental Emission Bandwidth.	20
7	Accreditation Documents	33

1 Test Report Scope and Limitations

1.1 Laboratory Authorization

Test Facility description and attenuation characteristics are on file with the FCC Laboratory, Columbia, Maryland (FCC Reg. No: US5348 and US5356) and with ISED Canada, Ottawa, ON (File Ref. No: US0213).

1.2 Report Retention

For equipment verified to comply with the regulations herein, the manufacturer is obliged to retain this report with the product records for the life of the product, and no less than ten years. A copy of this Report will remain on file with this laboratory until April 2029.

1.3 Subcontracted Testing

This report does not contain data produced under subcontract.

1.4 Limitation of Results

The test results contained in this report relate only to the item(s) tested. Any electrical or mechanical modification made to the test item subsequent to the test date shall invalidate the data presented in this report. Any electrical or mechanical modification made to the test item subsequent to this test date shall require reevaluation.

1.5 Copyright

This report shall not be reproduced, except in full, without the written approval of Amber Helm Development L.C.

1.6 Endorsements

This report shall not be used to claim product endorsement by any accrediting, regulatory, or governmental agency.

1.7 Test Location

The EUT was fully tested by **Amber Helm Development L.C.**, headquartered at 92723 Michigan Hwy-152, Sister Lakes, Michigan 49047 USA. Table 1 lists all sites employed herein. Specific test sites utilized are also listed in the test results sections of this report where needed.

Table 1: Test Site List.

Description	Location	Quality Num.
OATS (3 meter)	3615 E Grand River Rd., Williamston, Michigan 48895	OATSC

1.8 Traceability and Equipment Used

Pertinent test equipment used for measurements at this facility is listed in Table 2. The quality system employed at Amber Helm Development L.C. has been established to ensure all equipment has a clearly identifiable classification, calibration expiry date, and that all calibrations are traceable to the SI through NIST, other recognized national laboratories, accepted fundamental or natural physical constants, ratio type of calibration, or by comparison to consensus standards.

Table 2: Equipment List.

Description	Manufacturer/Model	SN	Quality Num.	Last Cal By / Date Due
Biconical	EMCO / 93110B	9802-3039	BICEMCO01	Keysight / Aug-2019
Log Periodic Antenna	EMCO / 3146	9305-3614	LOGEMCO01	Keysight / Aug-2019
BNC-BNC Coax	WRTL / RG58/U	001	CAB001-BLACK	AHD / Jul-2019
3.5-3.5MM Coax	PhaseFlex / PhaseFlex	001	CAB015-PURP	AHD / Jul-2019
Spectrum Analyzer	Rohde & Schwarz / FSV30	101660	RSFSV30001	RS / Apr-2021
Quad Ridge Horn	Singer / A6100	C35200	HQR1TO18S01	Keysight / Aug-2019

2 Test Specifications and Procedures

2.1 Test Specification and General Procedures

The ultimate goal of Continental Automotive is to demonstrate that the Equipment Under Test (EUT) complies with the Rules and/or Directives below. Detailed in this report are the results of testing the Continental Automotive RCKF Module for compliance to:

Country/Region	Rules or Directive	Referenced Section(s)
United States	Code of Federal Regulations	CFR Title 47, Part 15.231
Canada	ISED Canada	IC RSS-210/GENe

It has been determined that the equipment under test is subject to the rules and directives above at the date of this testing. In conjunction with these rules and directives, the following specifications and procedures are followed herein to demonstrate compliance (in whole or in part) with these regulations.

ANSI C63.4:2014	"Methods of Measurement of Radio-Noise Emissions from Low-Voltage Electrical and Electronic Equipment in the Range of 9 kHz to 40 GHz"
ANSI C63.10:2013	"American National Standard of Procedures for Compliance Testing of Unlicensed Wireless Devices"
TP0102RA	"AHD Internal Document TP0102 - Radiated Emissions Test Procedure"
ISED Canada	"The Measurement of Occupied Bandwidth"

3 Configuration and Identification of the Equipment Under Test

3.1 Description and Declarations

The equipment under test is a universal Remote Keyless Entry transmitter module. The EUT is approximately 8 x 3 x 1 cm in dimension, and is depicted in Figure 1. It is powered by 2.5-3.6 VDC battery. In use, this device is a modular transceiver intended for OEM integration into mobile and portable product lines. Table 3 outlines provider declared EUT specifications.

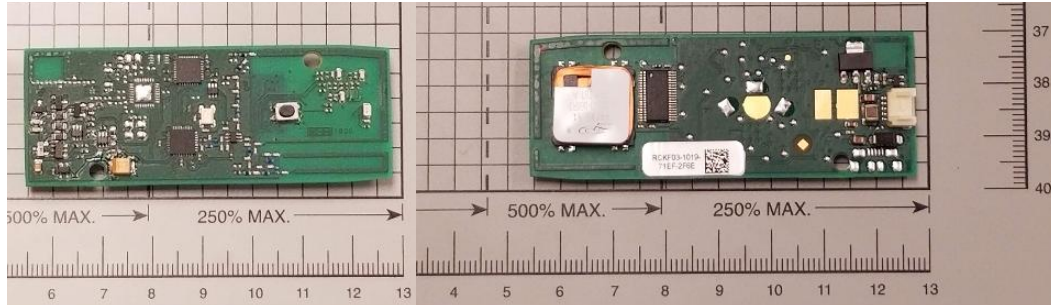

Figure 1: Photos of EUT.

Table 3: EUT Declarations.

General Declarations			
Equipment Type:	Limited Modular Transmitter	Country of Origin:	USA
Nominal Supply:	2.5-3.6 VDC	Oper. Temp Range:	-40°C to +85°C
Frequency Range:	312 – 318, 433.2 – 434.6, 868.1 – 868.5, 902.375 – 927.675 MHz	Antenna Dimension:	Not Declared
Antenna Type:	PCB Trace	Antenna Gain:	Integral
Number of Channels:	Not Declared	Channel Spacing:	Not Declared
Alignment Range:	Not Declared	Type of Modulation:	ASK (up to 9.6kbps), FSK (up to 9.6kbps)
United States			
FCC ID Number:	M3N-RCKF	Classification:	DSC
Canada			
IC Number:	7812A-RCKF	Classification:	Remote Control Device, Vehicular Device

3.1.1 EUT Configuration

The EUT is configured for testing as depicted in Figure 2.

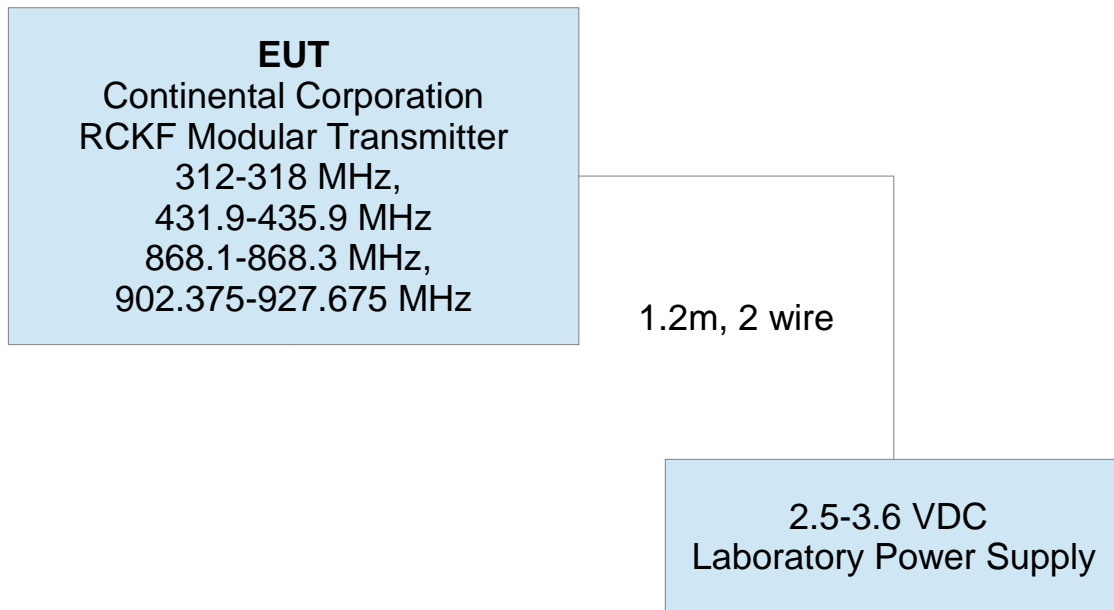

Figure 2: EUT Test Configuration Diagram.

3.1.2 Modes of Operation

This product is programmed to emulate existing RF keyfobs by selecting vehicle make, model, year, and host chassis information from the Continental secure APK linked to the Continental Remote Cloud Key database. After selecting vehicle make, model, and year the transmission protocol used by that vehicle (including frequency, modulation, and encoding sequence) is then downloaded into the RCKF module for use. As such, the EUT is designed to emulate a wide range of RKE (Remote Keyless Entry) devices. It transmits finite length ASK and FSK frames in the 315, 434, 868, and 915 MHz UHF frequency bands as a Security/Remote Control Transmitter. The RCK is not a learning or trained device and does not perform power level vs duty cycle calculations internally. The product is simply a programmable transmitter that can be programmed with only those power settings, modulations, and duty cycles (encoding - protocol) stored in the secure Continental Remote Cloud Key database in order to emulate existing Keyfob transmitters. In each operating band the protocols employed by this product may employ ASK or FSK modulation at data rates up to 9600 kbps. The EUT is capable of manual activation via a mechanical SMT switch (button) or automatic activation by serial i/o commands, or from detection of encoded LF (125 kHz) used in vehicle passive entry systems. For testing, this module was exercised at the lowest, middle, and highest operating frequencies in the 315, 434, and 915 MHz bands, and at the center frequency in the 868 MHz band (as that band is less than 1 MHz wide). At each frequency the EUT was tested at both the highest and lowest possible data rates for ASK and FSK transmission and at the highest, middle, and lowest duty cycles needed to fully exercise the power range of the EUT. Harmonic emissions are reported in the worst cases.

3.1.3 Variants

There is only a single variant of the module, as tested.

3.1.4 Test Samples

Two PCB module samples were provided in total, both capable of UHF programming via a software interface. Samples were tested in stand alone configuration.

3.1.5 Functional Exerciser

Normal operating EUT functionality was verified by observation of transmitted signal.

3.1.6 Modifications Made

There were no modifications made to the EUT by this laboratory, however extensive pretesting was performed after which the manufacturer selected the final power setting ranges and duty cycles allowed for use by the module.

3.1.7 Production Intent

The EUT appears to be a production ready sample.

3.1.8 Declared Exemptions and Additional Product Notes

This testing is performed on the EUT as a module, intended for installation into other host products. The encodings tested represent the limits of duty cycle that the manufacturer states it will implement at a given frequency. This report includes data for all frequencies with the EUT programmed at the manufacturers minimum and maximum duty cycle to demonstrate correct output power adjustment by the manufacturer. It is the manufacturer's responsibility to verify that all end (host) products into which this module is installed are fully compliant. The manufacturer declares the EUT can only be manually or automatically activated, and will never periodically transmit in the operating frequency bands. The manufacturer declares that the EUT will never employ more than three UHF band frequencies (channels) of operation after any single manual activation, and only in sequential order while operating with receivers configured to receive the same. The EUT will not transmit in the UHF band at more than a single frequency at a time and will never transmit for longer than 5 seconds after a manual activation. All UHF protocols that can be programmed into the module by the manufacturer are vehicle specific and are programmed via a proprietary and secure cloud based database service controlled by Continental Corporation. The testing herein is intended to

demonstrate the EUT's compliance across all authorized remote keyless entry protocols Continental Corporation may program the device to use.

4 Emissions

4.1 General Test Procedures

4.1.1 Radiated Test Setup and Procedures

Radiated electromagnetic emissions from the EUT are first pre-scanned in our screen room. Spectrum and modulation characteristics of all emissions are recorded. Instrumentation, including spectrum analyzers and other test equipment as detailed in Section 1.7 are employed. After pre-scan, emission measurements are made on the test site of record. If the EUT connects to auxiliary equipment and is table or floor standing, the configurations prescribed in relevant test standards are followed. Alternatively, a layout closest to normal use (as declared by the provider) is employed if the resulting emissions appear to be worst-case in such a configuration. See Figure 3. All intentionally radiating elements that are not fixed-mounted in use are placed on the test table lying flat, on their side, and on their end (3-axes) and the resulting worst case emissions are recorded. If the EUT is fixed-mounted in use, measurements are made with the device oriented in the manner consistent with installation and then emissions are recorded. If the EUT exhibits spurious emissions due to internal receiver circuitry, such emissions are measured with an appropriate carrier signal applied.

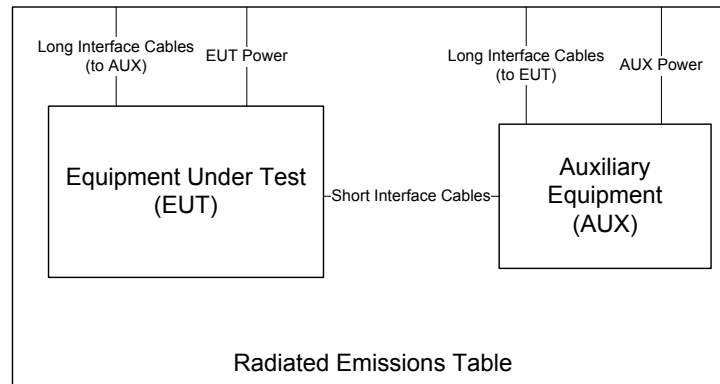

Figure 3: Radiated Emissions Diagram of the EUT.

For devices with intentional emissions below 30 MHz, a shielded loop antenna and/or E-field and H-Field broadband probes are used depending on the regulations. Shielded loops are placed at a 1 meter receive height at the desired measurement distance. For exposure in this band, the broadband probes employed are 10cm diameter single-axis shielded transducers and measurements are repeated and summed over three axes.

Emissions between 30 MHz and 1 GHz are measured using calibrated broadband antennas. For both horizontal and vertical polarizations, the test antenna is raised and lowered from 1 to 4 m in height until a maximum emission level is detected. The EUT is then rotated through 360° in azimuth until the highest emission is detected. The test antenna is then raised and lowered one last time from 1 to 4 m and the worst case value is recorded. Emissions above 1 GHz are characterized using standard gain or broadband ridge-horn antennas on our OATS with a 4×5 m rectangle of ECCOSORB absorber covering the OATS ground screen and a 1.5m table height. Care is taken to ensure that test receiver resolution and video bandwidths meet the regulatory requirements, and that the emission bandwidth of the EUT is not reduced. Photographs of the test setup employed are depicted in Figure 4.

Where regulations allow for direct measurement of field strength, power values (dBm) measured on the test receiver / analyzer are converted to $\text{dB}\mu\text{V}/\text{m}$ at the regulatory distance, using

$$E_{dist} = 107 + P_R + K_A - K_G + K_E - C_F$$

where P_R is the power recorded on spectrum analyzer, in dBm, K_A is the test antenna factor in dB/m, K_G is the combined pre-amplifier gain and cable loss in dB, K_E is duty correction factor (when applicable) in dB, and C_F is a distance conversion (employed only if limits are specified at alternate distance) in dB. This field strength value is then compared with the regulatory limit. If effective isotropic radiated power (EIRP) is computed, it is computed as

$$EIRP(\text{dBm}) = E_{3m}(\text{dB}\mu\text{V}/\text{m}) - 95.2.$$

When presenting data at each frequency, the highest measured emission under all possible EUT orientations (3-axes) is reported.

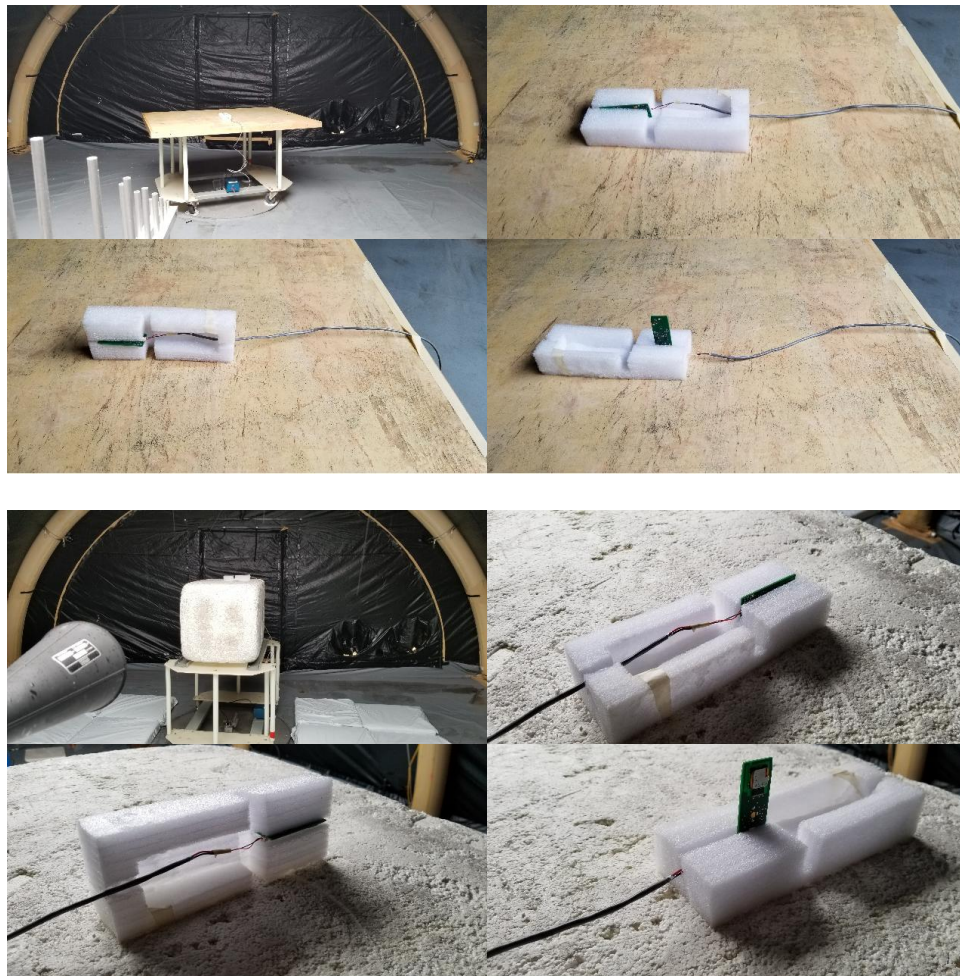

Figure 4: Radiated Emissions Test Setup Photograph(s).

4.1.2 Conducted Emissions Test Setup and Procedures

4.1.3 Power Supply Variation

Tests at extreme supply voltages are made if required by the procedures specified in the test standard, and results of this testing are detailed in this report.

4.2 Intentional Emissions

4.2.1 Fundamental Emission Pulsed Operation

Test Setup & Procedure The test equipment and facilities were setup in accordance with the standards and procedures listed in Section 2.1. Environmental conditions were set at the appropriate temperature and thermal balance was checked with a thermocouple based probe. Duty cycle is reported for all relevant modes of operation. The test equipment employed includes RSFSV30001, LOGEMCO01.

Measurement Results The details and results of testing the EUT are summarized in Table 4. Plots showing the measurements made to obtain these values are provided in Figure 5.

Table 4: Fundamental Emission Pulsed Operation.

Detector	Span	IF Bandwidth	Video Bandwidth	Test Date:
Pk	0	1 MHz	3 MHz	02/25, 03/21, 03/25/2019
				Test Engineer:
				J. Brunett
				EUT:
				Conti RCKF
				EUT Mode:
				9.6 kbps, See Table
				Meas. Distance:
				10 cm

FCC/IC										
R0	Test Freq. (MHz)	EUT Test Mode*	Overall Transmission			Internal Frame Characteristics			Computed Duty Cycle	
			Min. Repetition Rate (sec)	Max. No. of Frames	Total Transmission Length (sec)	Max. Frame Length (ms)	Min. Frame Period (ms)	Frame Encoding	(%)	(dB)
R1	315	Manual Activated, FSK	single	1	0.10	100.10	-	In the worse case, the EUT transmits one 100.1 ms FSK frame.	100.0	0.0
R2	315	Manual Activated, FSK	single	1	0.04	40.10	-	In the worse case, the EUT transmits one 40.1 ms FSK frame.	40.1	-7.9
R3	315	Manual Activated, ASK	single	1	0.32	32.00	-	In the worse case, the EUT transmits one 32.0 ms Manchester encoded ASK frame with 0.105 / 0.210 ms duty.	16.0	-15.9
R4	433.92	Manual Activated, FSK	single	1	0.10	100.10	-	In the worse case, the EUT transmits one 100.1 ms FSK frame.	100.0	0.0
R5	433.92	Manual Activated, ASK	single	1	0.09	90.00	-	In the worse case, the EUT transmits one 90.0 ms Manchester encoded ASK frame with 0.110 / 0.220 ms duty.	45.0	-6.9
R6	433.92	Manual Activated, ASK	single	1	0.04	39.90	-	In the worse case, the EUT transmits one 39.9 ms Manchester encoded ASK frame with 0.110 / 0.220 ms duty.	20.0	-14.0
R7	868.3	Manual Activated, FSK	single	1	0.10	100.10	-	In the worse case, the EUT transmits one 100.1 ms FSK frame.	100.0	0.0
R8	868.3	Manual Activated, FSK	single	1	0.06	63.00	-	In the worse case, the EUT transmits one 63.0 ms FSK frame.	63.0	-4.0
R9	868.3	Manual Activated, FSK	single	1	0.08	80.10	-	In the worse case, the EUT transmits one 80.1 ms Manchester encoded ASK frame with 0.110 / 0.220 ms duty.	40.1	-7.9
R10	902.375	Manual Activated, FSK	single	1	0.10	100.10	-	In the worse case, the EUT transmits one 100.1 ms FSK frame.	100.0	0.0
R11	902.375	Manual Activated, ASK	single	1	0.10	100.10	-	In the worse case, the EUT transmits one 100.1 ms Manchester encoded ASK frame with 0.105 / 0.210 ms duty.	50.1	-6.0
R12	915	Manual Activated, FSK	single	1	0.25	25.00	-	In the worse case, the EUT transmits one 25.0 ms FSK frame.	25.0	-12.0
#	C1	C2	C3	C4	C5	C6	C7	C8	C9	C10

Example Calculation: Lowest Duty (%) = (100 ms) / 100 ms = 100% on-time.
 Example Calculation: Highest Duty (%) = (32 ms x 0.105 / 0.210 ms) / 100 ms = 16% on-time.

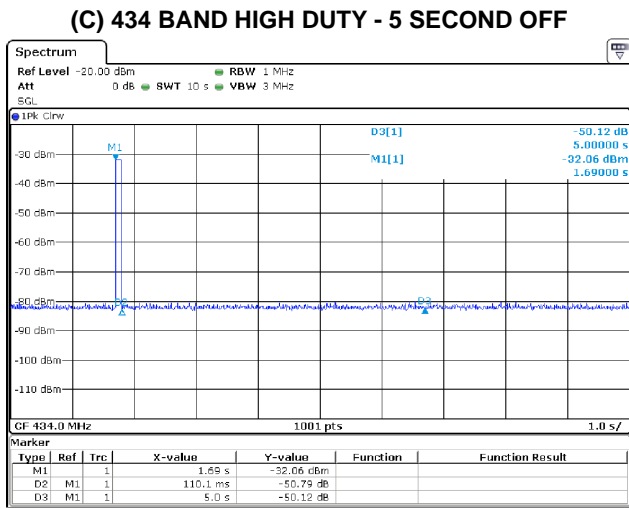
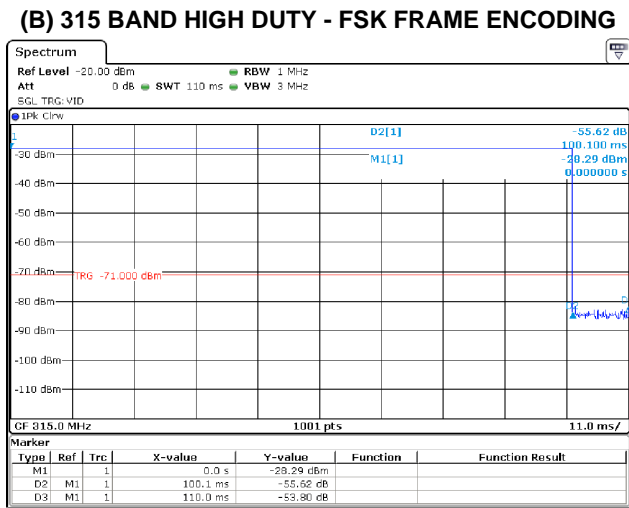
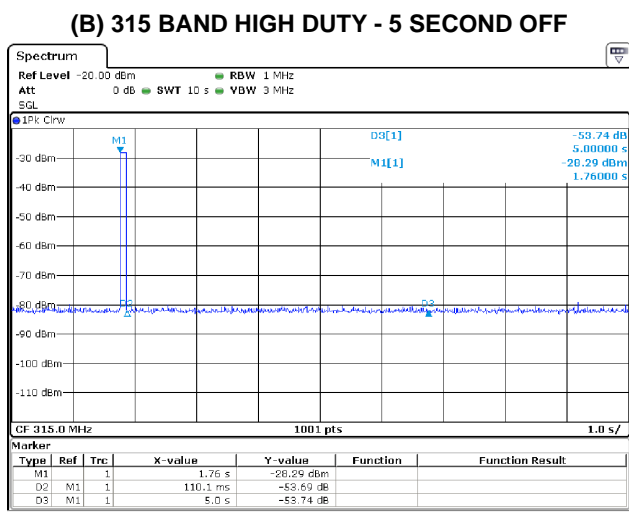
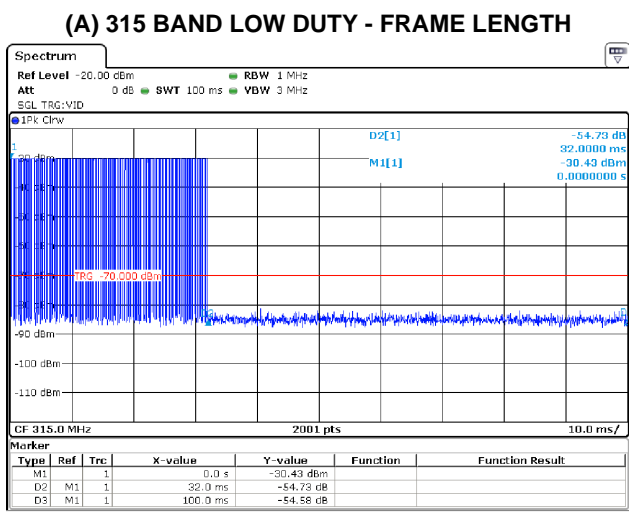
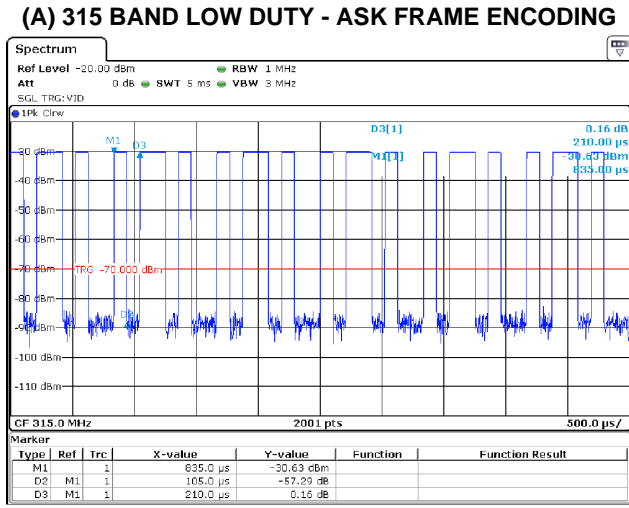
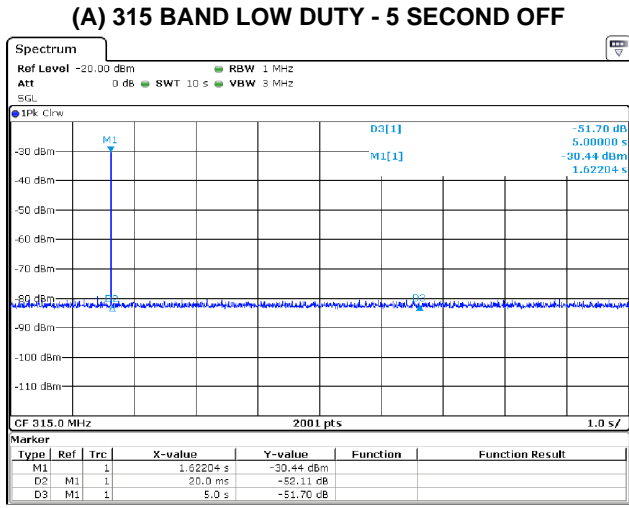
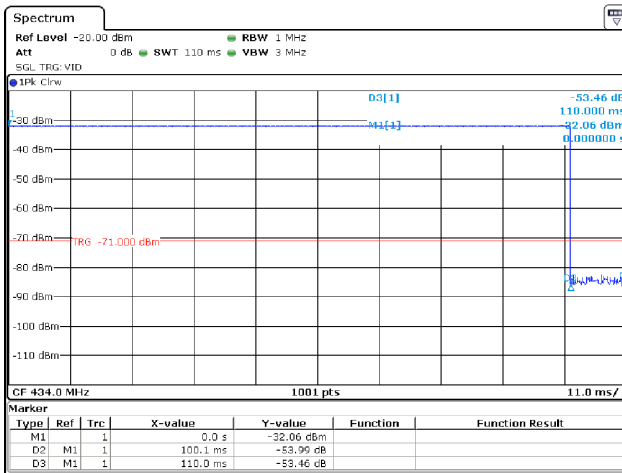
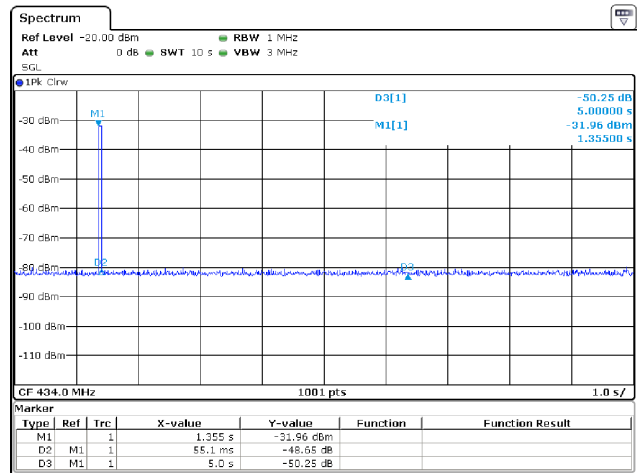

Figure 5(a): Fundamental Emission Pulsed Operation.

(C) 434 BAND HIGH DUTY - FSK FRAME ENCODING



(D) 434 BAND LOW DUTY - 5 SECOND OFF



(D) 434 BAND LOW DUTY - ASK FRAME ENCODING

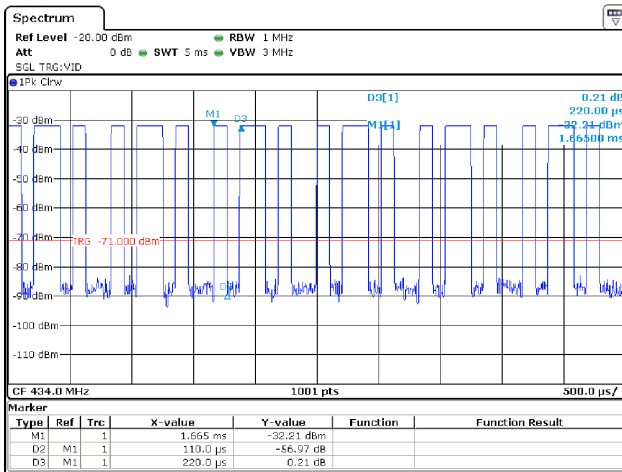

(D) 434 BAND LOW DUTY - ASK FRAME LENGTH

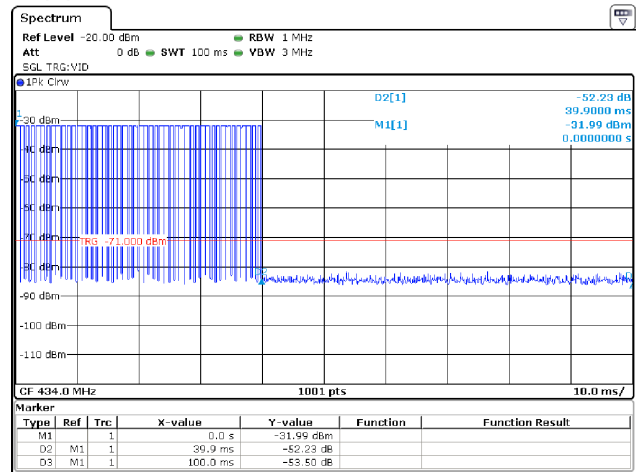

(E) 868 BAND HIGH DUTY - 5 SECOND OFF

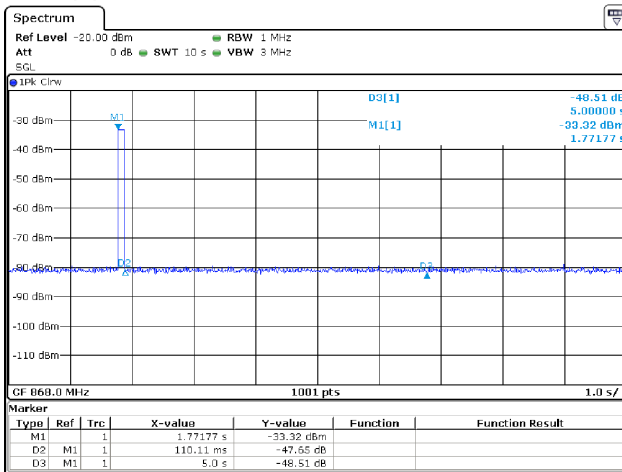

(E) 868 BAND HIGH DUTY - FSK FRAME LENGTH

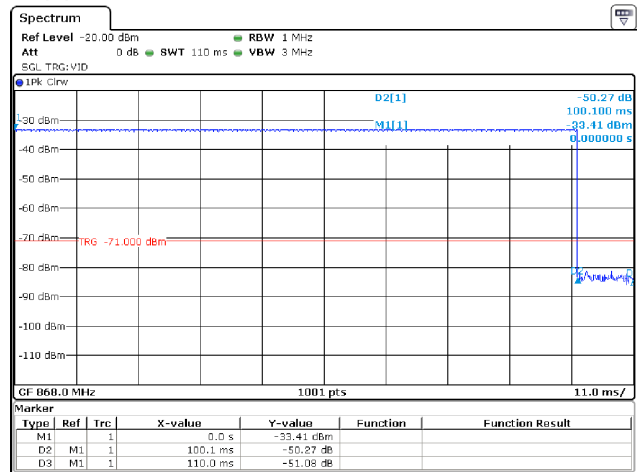
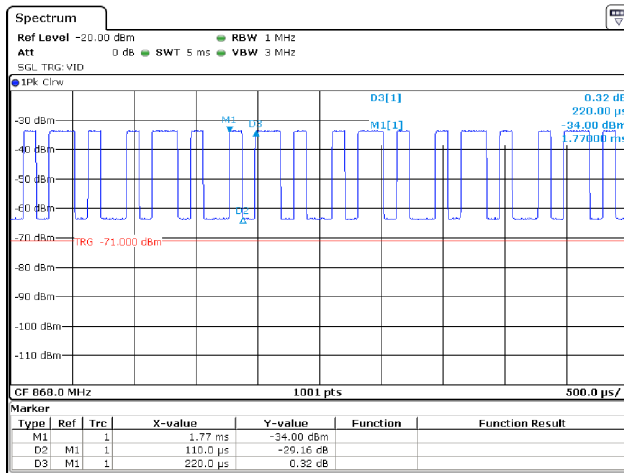
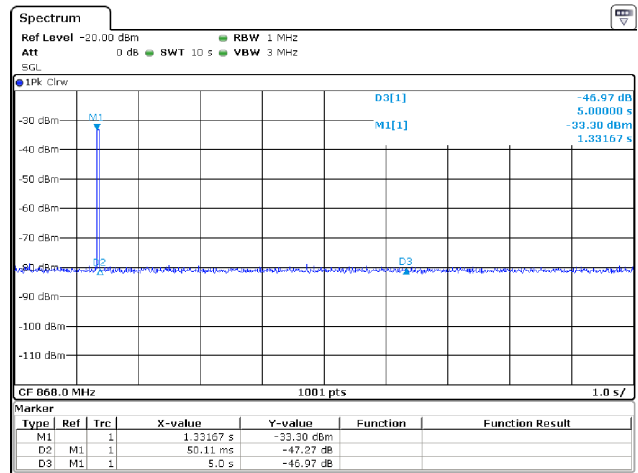

Figure 5(b): Fundamental Emission Pulsed Operation.

(F) 868 BAND - LOW DUTY - ASK FRAME ENCODING



(F) 868 BAND LOW DUTY - 5 SECOND OFF



(F) 868 BAND LOW DUTY - ASK FRAME LENGTH

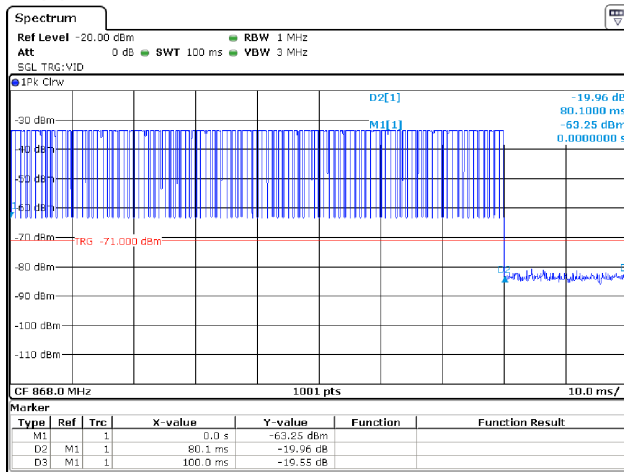

(G) 915 BAND MID DUTY - 5 SECOND OFF

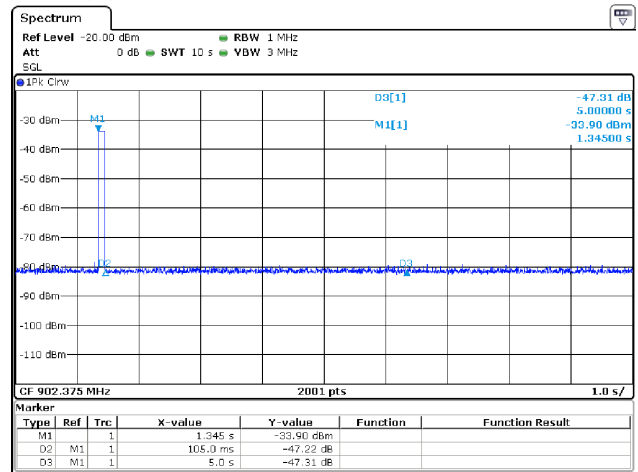

(G) 915 BAND MID DUTY - ASK FRAME ENCODING

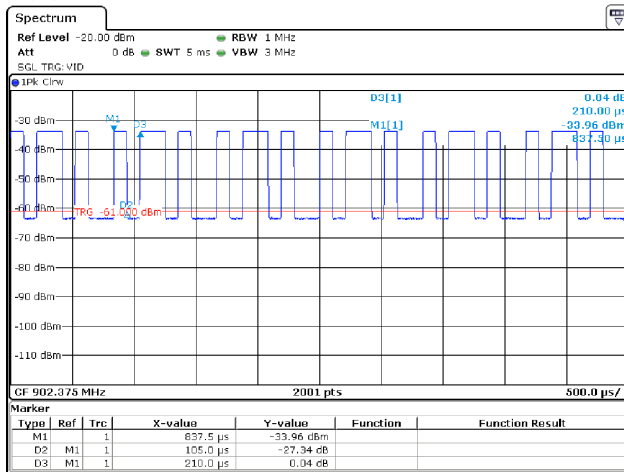

(G) 915 BAND MID DUTY - ASK FRAME LENGTH

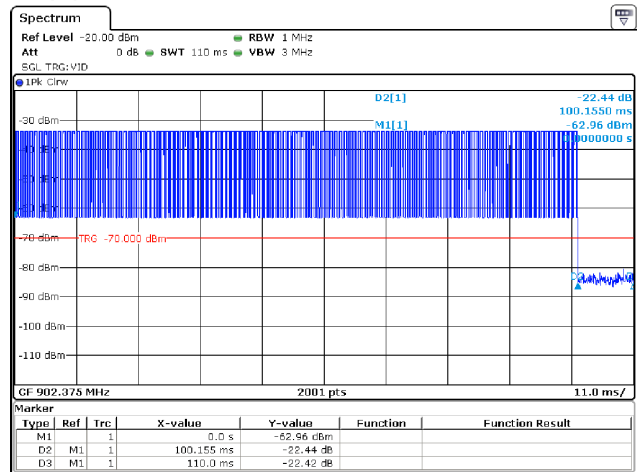

Figure 5(c): Fundamental Emission Pulsed Operation.

4.2.2 Fundamental Emission Bandwidth

Test Setup & Procedure The test equipment and facilities were setup in accordance with the standards and procedures listed in Section 2.1. Environmental conditions were set at the appropriate temperature and thermal balance was checked with a thermocouple based probe. Emission bandwidth (EBW) of the EUT is measured with the device placed in the test mode(s) with the shortest available frame length and minimum frame spacing. The 20 dB EBW is measured as the max-held peak-detected signal when the IF bandwidth is greater than or equal to 1% of the receiver span. For complex modulations other than ASK and FSK, the 99% emission bandwidth per IC test procedures has a different result, and is also reported. The test equipment employed includes RSFSV30001, LOGEMCO01.

Measurement Results The details and results of testing the EUT are summarized in Table 5. Plots showing the measurements made to obtain these values are provided in Figure 6.

Table 5: Fundamental Emission Bandwidth.

Detector	IF Bandwidth	Video Bandwidth	Test Date:	02/25, 03/21, 03/25/2019
Pk	10 kHz	30 kHz	Test Engineer:	J. Brunett
			EUT:	Conti RCKF
			EUT Mode:	9.6 kbps, See Table
			Meas. Distance:	10 cm

							FCC/IC	
R0	Mode	Center Frequency (MHz)	20 dB EBW (MHz)	EBW Limit (MHz)	99% OBW (MHz)	3CH Sum 20dB OBW (MHz)	Min EBW Limit (MHz)	
R1	ASK	312.00	0.052	0.780	0.168	0.398	0.780	
R2	FSK	312.00	0.127	0.780	0.149			
R3	ASK	315.00	0.051	0.788	0.160			
R4	FSK	315.00	0.129	0.788	0.153			
R5	ASK	318.00	0.054	0.795	0.145			
R6	FSK	318.00	0.123	0.795	0.125			
R7	ASK	431.90	0.053	1.080	0.199			
R8	FSK	431.90	0.128	1.080	0.147			
R9	ASK	433.92	0.055	1.085	0.213			
R10	FSK	433.92	0.130	1.085	0.152			
R11	ASK	435.90	0.053	1.090	0.201			
R12	FSK	435.90	0.129	1.090	0.153			
R13	ASK	868.30	0.055	2.171	0.166			
R14	FSK	868.30	0.129	2.171	0.146			
R15	ASK	902.38	0.059	4.512	0.214			
R16	FSK	902.38	0.133	4.512	0.155			
R17	ASK	915.00	0.051	4.575	0.139			
R18	FSK	915.00	0.130	4.575	0.137			
R19	ASK	927.68	0.061	4.638	0.224			
R20	FSK	927.68	0.135	4.638	0.152			
#	C1	C2	C3	C4	C5	C7	C8	

(ROW) (COLUMN) NOTE:

R0 C8 Per KDB 926416, for FCC 15.231 non-sweeping devices, total bandwidth is sum of the individual occupied 20 dB bandwidths. At most the manuf. uses 3 channels. Device bandwidth is restricted to 0.0025 (.25%) of the center frequency. Three Maximum 20dB EBWs summation is 0.133 MHz + 0.130 MHz + 0.135 MHz = 0.398 MHz

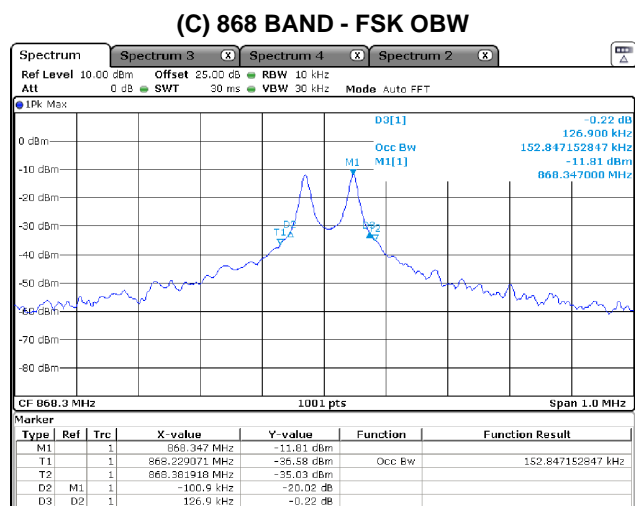
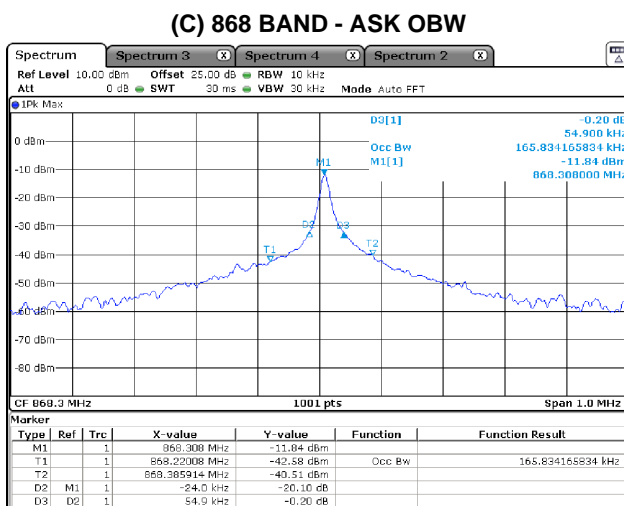
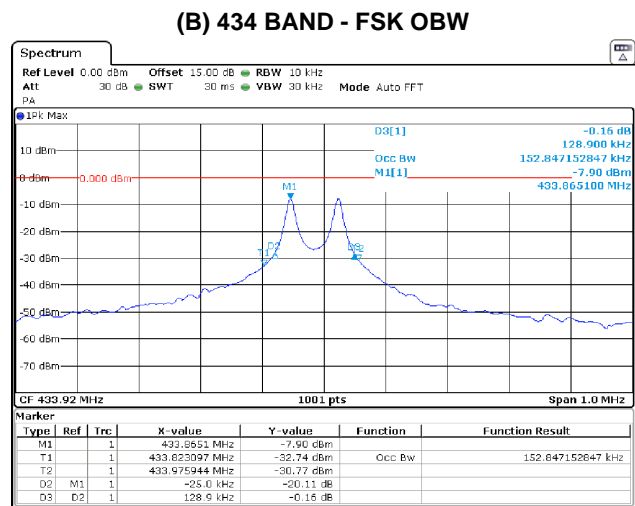
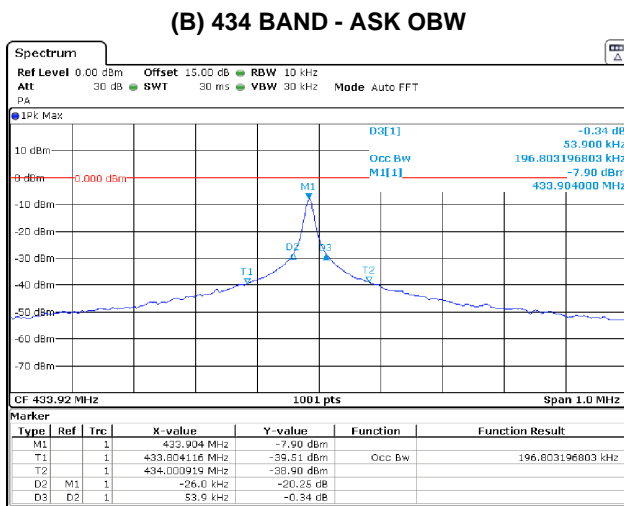
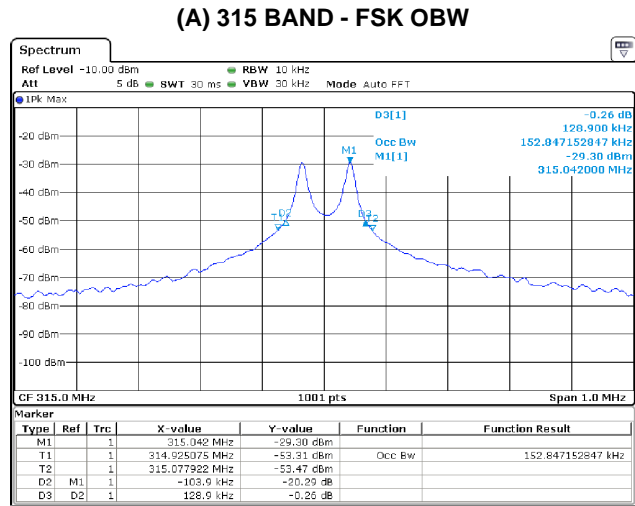
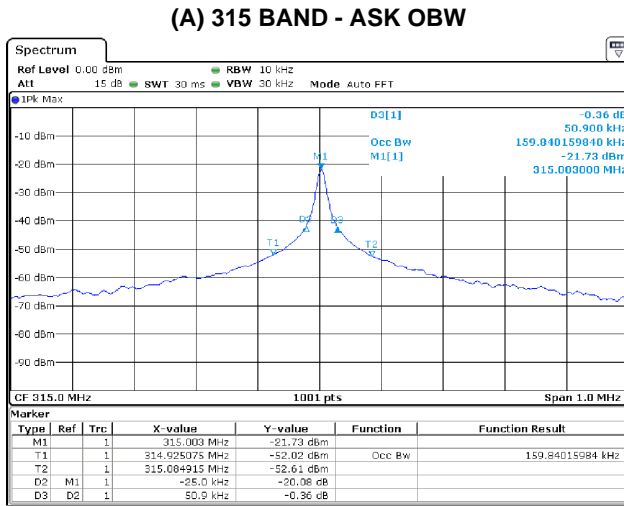

Figure 6(a): Fundamental Emission Bandwidth.

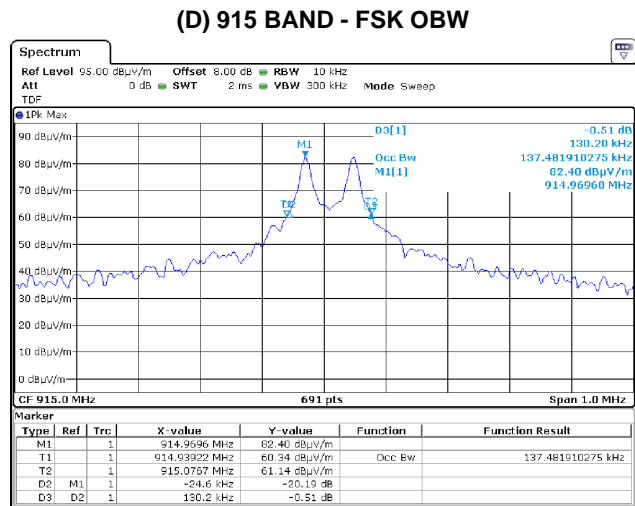
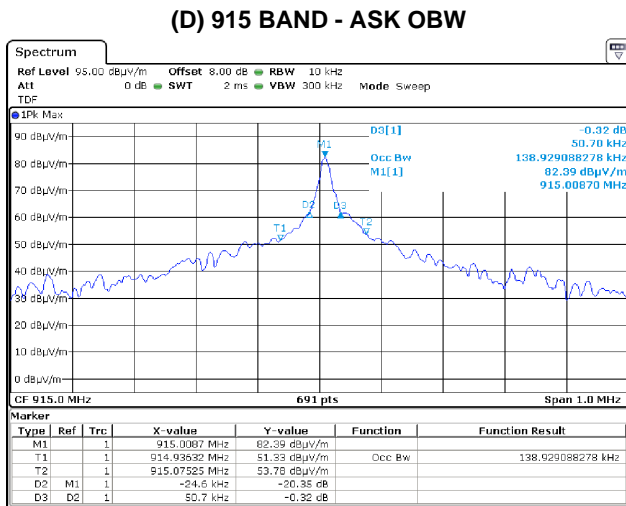

Figure 6(b): Fundamental Emission Bandwidth.

4.2.3 Fundamental Emission Field Strength

Test Setup & Procedure The test equipment and facilities were setup in accordance with the standards and procedures listed in Section 2.1. Environmental conditions were set at the appropriate temperature and thermal balance was checked with a thermocouple based probe. Fundamental emissions are measured at the regulatory distance on our OATS. The test equipment employed includes RSFSV30001, LOGEMCO01.

Measurement Results The details and results of testing the EUT are summarized in Table 6.

Table 6(a): Fundamental Emission Field Strength.

EUT Modes: a1 315 BAND - 15.9 DB DUTY - MAX POWER (0x73) a5
 a2 434 BAND - 14 DB DUTY - MAX POWER (0x73) a6
 Test Date(s): 2/1, 2/4, 3/12, 3/20/2019 a3 868 BAND - 7.9 DB DUTY - MAX POWER (0x73) a7
 Test Engineer: J. Brunett a4 915 BAND - 12 DB DUTY - MAX POWER (0x73) a8

R0	Frequency		Temp. (C) Hum. %	Table Angle deg	Site				EUT				Test Antenna				Cable Kg	Receiver				Field Strength @ DR						EIRP		Details Pass Fail dB
	Start MHz	Stop MHz			MR	DR	N/F	CF	Mode see table	Volt. (V)	Dim cm	Pol. H/V	Ant. Height m	Dim. cm	Ka dB/m	Rx Power Pk dBm		Avg	Bandwidth RBW MHz	VBW	Meas.	Pk Limit USA	Qpk / Avg Limit CAN	Pk Calc.	Qpk / Avg Limit USA	Pk Calc.	Worst Case Orient			
					m			dB														dBUV/m		dBUV/m						
R1	SETUP		OATSC				PCB ONLY				EMCOLOG				CAB001	RSFSV30001				NOTES: H-POL - FLAT, V-POL END Worst Case Orient										
R2	312.0	312.0	14/21	0.0	3.0	3.0		0.0	a1	3.0	8.0	H	1.0	100.0	14.0	-0.1		0.12	0.30	89.3	95.4	95.4	73.4	75.4	75.4	-5.8		2.0		
R3	312.0	312.0	14/21	90.0	3.0	3.0		0.0	a1	3.0	8.0	V	1.5	100.0	14.0	-0.1		0.12	0.30	82.5	95.4	95.4	66.6	75.4	75.4	-12.6		8.8		
R4	315.0	315.0	14/21	0.0	3.0	3.0		0.0	a1	3.0	8.0	H	1.0	100.0	14.1	-0.1		0.12	0.30	90.6	95.6	95.6	74.7	75.6	75.6	-4.5		0.9		
R5	315.0	315.0	14/21	90.0	3.0	3.0		0.0	a1	3.0	8.0	V	1.5	100.0	14.1	-0.1		0.12	0.30	83.8	95.6	95.6	67.9	75.6	75.6	-11.3		7.7		
R6	318.0	318.0	14/21	0.0	3.0	3.0		0.0	a1	3.0	8.0	H	1.0	100.0	14.1	-0.1		0.12	0.30	89.0	95.8	95.8	73.1	75.8	75.8	-6.1		2.7		
R7	318.0	318.0	14/21	90.0	3.0	3.0		0.0	a1	3.0	8.0	V	1.5	100.0	14.1	-0.1		0.12	0.30	82.2	95.8	95.8	66.3	75.8	75.8	-12.9		9.5		
R8																														
R9	431.9	431.9	-4/22	0.0	3.0	3.0		0.0	a2	3.0	8.0	H	1.0	100.0	16.3	-0.1		0.12	0.30	92.0	100.8	100.8	78.0	80.8	80.8	-3.1		2.8		
R10	431.9	431.9	-4/22	90.0	3.0	3.0		0.0	a2	3.0	8.0	V	1.3	100.0	16.3	-0.1		0.12	0.30	90.1	100.8	100.8	76.1	80.8	80.8	-5.0		4.7		
R11	433.9	433.9	-4/22	0.0	3.0	3.0		0.0	a2	3.5	8.0	H	1.0	100.0	16.3	-0.1		0.12	0.30	92.4	100.8	100.8	78.4	80.8	80.8	-2.7		2.4		
R12	433.9	433.9	-4/22	0.0	3.0	3.0		0.0	a2	3.0	8.0	H	1.0	100.0	16.3	-0.1		0.12	0.30	92.4	100.8	100.8	78.4	80.8	80.8	-2.7		2.4		
R13	433.9	433.9	-4/22	0.0	3.0	3.0		0.0	a2	2.7	8.0	H	1.0	100.0	16.3	-0.1		0.12	0.30	92.4	100.8	100.8	78.4	80.8	80.8	-2.7		2.4		
R14	433.9	433.9	-4/22	0.0	3.0	3.0		0.0	a2	2.6	8.0	H	1.0	100.0	16.3	-0.1		0.12	0.30	92.4	100.8	100.8	78.4	80.8	80.8	-2.7		2.3		
R12	433.9	433.9	-4/22	90.0	3.0	3.0		0.0	a2	2.5	8.0	V	1.3	100.0	16.3	-0.1		0.12	0.30		100.8	100.8		80.8	80.8			off		
R13	435.9	435.9	-4/22	0.0	3.0	3.0		0.0	a2	3.0	8.0	H	1.0	100.0	16.4	-0.1		0.12	0.30	93.0	100.9	100.9	79.0	80.9	80.9	-2.1		1.9		
R14	435.9	435.9	-4/22	90.0	3.0	3.0		0.0	a2	3.0	8.0	V	1.3	100.0	16.4	-0.1		0.12	0.30	91.1	100.9	100.9	77.1	80.9	80.9	-4.0		3.8		
R15																														
R16	868.3	868.3	8/51	0.0	3.0	3.0		0.0	a3	3.0	8.0	H	1.0	100.0	22.2	-0.2		0.12	0.30	88.5	101.9	101.9	80.6	81.9	81.9	-6.6		1.3		
R17	868.3	868.3	8/51	90.0	3.0	3.0		0.0	a3	3.0	8.0	V	1.1	100.0	22.2	-0.2		0.12	0.30	88.6	101.9	101.9	80.7	81.9	81.9	-6.5		1.2		
R18																														
R19	902.375	902.375	14/21	0.0	3.0	3.0		0.0	a10	3.0	8.0	H	1.0	100.0	22.6	-0.2		0.12	0.30	90.6	101.9	101.9	78.6	81.9	81.9	-8.7		3.3		
R20	902.375	902.375	14/21	90.0	3.0	3.0		0.0	a10	3.0	8.0	V	1.5	100.0	22.6	-0.2		0.12	0.30	88.4	101.9	101.9	76.4	81.9	81.9	-10.9		5.5		
R21	915.000	915.000	14/21	0.0	3.0	3.0		0.0	a10	3.0	8.0	H	1.0	100.0	22.7	-0.2		0.12	0.30	89.5	101.9	101.9	77.5	81.9	81.9	-9.8		4.4		
R22	915.000	915.000	14/21	90.0	3.0	3.0		0.0	a10	3.0	8.0	V	1.5	100.0	22.7	-0.2		0.12	0.30	87.4	101.9	101.9	75.4	81.9	81.9	-11.9		6.5		
R23	927.675	927.675	14/21	0.0	3.0	3.0		0.0	a10	3.0	8.0	H	1.0	100.0	22.9	-0.2		0.12	0.30	92.9	101.9	101.9	80.9	81.9	81.9	-6.4		1.0		
R24	927.675	927.675	14/21	90.0	3.0	3.0		0.0	a10	3.0	8.0	V	1.5	100.0	22.9	-0.2		0.12	0.30	90.8	101.9	101.9	78.8	81.9	81.9	-8.5		3.1		
R25																														
#	C1	C2	C3	C4	C5	C6	C7	C8	C9	C10	C11	C12	C13	C14	C15	C16	C17	C18	C19	C20	C21	C22	C23	C24	C25	C26	C27	C28	C29	

(ROW) (COLUMN) NOTE:
 R0 C5 MR is Measurement Range, which is reduced from DR to achieve necessary SNR.
 R0 C6 DR is the regulatory Desired Range measurement distance.
 R0 C7 N/F is Near-Field / Far-Field distance computed for max of EUT Antenna Dimension (C10) computed above 1 GHz.
 R0 C8 CF is computed using a 20 dB/decade Decay Rate.
 R0 C18/19 When E-field or EIRP is reported directly from Spectrum Analyzer, Antenna Factors and Cable losses are included directly in SA settings and Pr is not reported.

Table 6(b): Fundamental Emission Field Strength.

EUT Modes: a4 315 BAND - 7.9 DB DUTY - MID POWER (0x53) a8
 a5 434 BAND - 6.9 DB DUTY - MID POWER (0x57) a9
 Test Date(s): 2/1, 2/4, 3/12, 3/20/2019 a6 868 BAND - 4 DB DUTY - MID POWER (0x63) a10
 Test Engineer: J. Brunett a7 915 BAND - 6 DB DUTY - MID POWER (0x63) a11

R0	Frequency		Temp. (C) Hum.	Table Angle deg	Site				EUT				Test Antenna				Cable Kg	Receiver				Field Strength @ DR				EIRP		Details Pass Fail dB		
	Start MHz	Stop MHz			MR	DR	N/F	CF	Mode see table	Volt. (V)	Dim cm	Pol. H/V	Ant. Height m	Dim. cm	Ka dB/m	Rx Power Pk dBm		Avg	Bandwidth RBW MHz	VBW	Meas.	Limit USA	Limit CAN	Calc.	Qpk / Avg Limit USA	Limit CAN	Calc.		Pk dBm	Worst Case Orient
	MHz	MHz			%	deg	m	dB	table	(V)	cm	H/V	m	cm	dB/m	dBm			MHz		dBuV/m	dBuV/m	dBuV/m	dBuV/m	dBuV/m	dBuV/m	dBuV/m		dBm	
R1	SETUP				OATSC				PCB ONLY				EMCOLOG				CAB001	RSFSV30001				NOTES: H-POL - FLAT, V-POL END Worst Case Orient								
R2	312.0	312.0	14/21	0.0	3.0	3.0		0.0	a4	3.0	8.0	H	1.0	100.0	14.0	-0.1		0.12	0.30	81.7	95.4	95.4	73.8	75.4	75.4	-13.4		1.6		
R3	312.0	312.0	14/21	90.0	3.0	3.0		0.0	a4	3.0	8.0	V	1.5	100.0	14.0	-0.1		0.12	0.30	74.6	95.4	95.4	66.7	75.4	75.4	-20.5		8.7		
R4	315.0	315.0	14/21	0.0	3.0	3.0		0.0	a4	3.0	8.0	H	1.0	100.0	14.1	-0.1		0.12	0.30	82.7	95.6	95.6	74.8	75.6	75.6	-12.4		0.9		
R5	315.0	315.0	14/21	90.0	3.0	3.0		0.0	a4	3.0	8.0	V	1.5	100.0	14.1	-0.1		0.12	0.30	76.0	95.6	95.6	68.1	75.6	75.6	-19.1		7.6		
R6	318.0	318.0	14/21	0.0	3.0	3.0		0.0	a4	3.0	8.0	H	1.0	100.0	14.1	-0.1		0.12	0.30	81.3	95.8	95.8	73.4	75.8	75.8	-13.8		2.4		
R7	318.0	318.0	14/21	90.0	3.0	3.0		0.0	a4	3.0	8.0	V	1.5	100.0	14.1	-0.1		0.12	0.30	74.3	95.8	95.8	66.4	75.8	75.8	-20.8		9.4		
R8																														
R9	431.9	431.9	-4/22	0.0	3.0	3.0		0.0	a5	3.0	8.0	H	1.0	100.0	16.3	-0.1		0.12	0.30	85.1	100.8	100.8	78.2	80.8	80.8	-10.0		2.5		
R10	431.9	431.9	-4/22	90.0	3.0	3.0		0.0	a5	3.0	8.0	V	1.3	100.0	16.3	-0.1		0.12	0.30	83.2	100.8	100.8	76.3	80.8	80.8	-11.9		4.5		
R11	433.9	433.9	-4/22	0.0	3.0	3.0		0.0	a5	3.0	8.0	H	1.0	100.0	16.3	-0.1		0.12	0.30	85.4	100.8	100.8	78.5	80.8	80.8	-9.7		2.3		
R12	433.9	433.9	-4/22	90.0	3.0	3.0		0.0	a5	3.0	8.0	V	1.3	100.0	16.3	-0.1		0.12	0.30	84.0	100.8	100.8	77.1	80.8	80.8	-11.1		3.7		
R13	435.9	435.9	-4/22	0.0	3.0	3.0		0.0	a5	3.0	8.0	H	1.0	100.0	16.4	-0.1		0.12	0.30	86.0	100.9	100.9	79.1	80.9	80.9	-9.1		1.8		
R14	435.9	435.9	-4/22	90.0	3.0	3.0		0.0	a5	3.0	8.0	V	1.3	100.0	16.4	-0.1		0.12	0.30	84.6	100.9	100.9	77.7	80.9	80.9	-10.5		3.2		
R15																														
R16	868.3	868.3	8/51	0.0	3.0	3.0		0.0	a6	3.0	8.0	H	1.0	100.0	22.2	-0.2		0.12	0.30	84.7	101.9	101.9	80.7	81.9	81.9	-10.4		1.2		
R17	868.3	868.3	8/51	90.0	3.0	3.0		0.0	a6	3.0	8.0	V	1.1	100.0	22.2	-0.2		0.12	0.30	85.0	101.9	101.9	81.0	81.9	81.9	-10.1		1.0		
R18																														
R19	902.375	902.375	14/21	0.0	3.0	3.0		0.0	a10	3.0	8.0	H	1.0	100.0	22.6	-0.2		0.12	0.30	84.3	101.9	101.9	78.3	81.9	81.9	-15.0		3.6		
R20	902.375	902.375	14/21	90.0	3.0	3.0		0.0	a10	3.0	8.0	V	1.5	100.0	22.6	-0.2		0.12	0.30	82.2	101.9	101.9	76.2	81.9	81.9	-17.1		5.7		
R21	915.000	915.000	14/21	0.0	3.0	3.0		0.0	a10	3.0	8.0	H	1.0	100.0	22.7	-0.2		0.12	0.30	83.5	101.9	101.9	77.5	81.9	81.9	-15.8		4.4		
R22	915.000	915.000	14/21	90.0	3.0	3.0		0.0	a10	3.0	8.0	V	1.5	100.0	22.7	-0.2		0.12	0.30	81.1	101.9	101.9	75.1	81.9	81.9	-18.2		6.8		
R23	927.675	927.675	14/21	0.0	3.0	3.0		0.0	a10	3.0	8.0	H	1.0	100.0	22.9	-0.2		0.12	0.30	86.4	101.9	101.9	80.4	81.9	81.9	-12.9		1.5		
R24	927.675	927.675	14/21	90.0	3.0	3.0		0.0	a10	3.0	8.0	V	1.5	100.0	22.9	-0.2		0.12	0.30	84.7	101.9	101.9	78.7	81.9	81.9	-14.6		3.2		
R25																														
#	C1	C2	C3	C4	C5	C6	C7	C8	C9	C10	C11	C12	C13	C14	C15	C16	C17	C18	C19	C20	C21	C22	C23	C24	C25	C26	C27	C28	C29	

(ROW) (COLUMN) NOTE:
 R0 C5 MR is Measurement Range, which is reduced from DR to achieve necessary SNR.
 R0 C6 DR is the regulatory Desired Range measurement distance.
 R0 C7 N/F is Near-Field / Far-Field distance computed for max of EUT Antenna Dimension (C10) computed above 1 GHz.
 R0 C8 CF is computed using a 20 dB/decade Decay Rate.
 R0 C18/19 When E-field or EIRP is reported directly from Spectrum Analyzer, Antenna Factors and Cable losses are included directly in SA settings and Pr is not reported.

Table 6(c): Fundamental Emission Field Strength.

EUT Modes: a7 315 BAND - 0 DB DUTY - MIN POWER (0x33) a11
 a8 434 BAND - 0 DB DUTY - MIN POWER (0x3B) a12
 Test Date(s): 2/1, 2/4, 3/12, 3/20/2019 a9 868 BAND - 0 DB DUTY - MIN POWER (0x53) a13
 Test Engineer: J. Brunett a10 915 BAND - 0 DB DUTY - MIN POWER (0x43) a14

R0	Frequency		Temp. (C) Hum.	Table Angle deg	Site				EUT				Test Antenna				Cable Kg	Receiver				Field Strength @ DR				EIRP		Details Pass Fail dB		
	Start MHz	Stop MHz			MR	DR	N/F	CF	Mode see table	Volt. (V)	Dim cm	Pol. H/V	Ant. Height m	Dim. cm	Ka dB/m	Rx Power Pk dBm		Avg	Bandwidth RBW MHz	VBW	Meas.	Limit USA	Limit CAN	Calc.	Qpk / Avg Limit USA	Qpk / Avg Limit CAN	Calc.		Worst Case	Orient
R1	SETUP				OATSC				PCB ONLY				EMCOLOG				CAB001	RSFSV30001				NOTES: H-POL - FLAT, V-POL END Worst Case Orient								
R2	312.0	312.0	14/21	0.0	3.0	3.0		0.0	a7	3.0	8.0	H	1.0	100.0	14.0	-0.1		0.12	0.30	70.2	95.4	95.4	70.2	75.4	75.4	-25.0		5.2		
R3	312.0	312.0	14/21	90.0	3.0	3.0		0.0	a7	3.0	8.0	V	1.5	100.0	14.0	-0.1		0.12	0.30	66.1	95.4	95.4	66.1	75.4	75.4	-29.1		9.3		
R4	315.0	315.0	14/21	0.0	3.0	3.0		0.0	a7	3.0	8.0	H	1.0	100.0	14.1	-0.1		0.12	0.30	71.4	95.6	95.6	71.4	75.6	75.6	-23.8		4.2		
R5	315.0	315.0	14/21	90.0	3.0	3.0		0.0	a7	3.0	8.0	V	1.5	100.0	14.1	-0.1		0.12	0.30	67.2	95.6	95.6	67.2	75.6	75.6	-28.0		8.4		
R6	318.0	318.0	14/21	0.0	3.0	3.0		0.0	a7	3.0	8.0	H	1.0	100.0	14.1	-0.1		0.12	0.30	72.6	95.8	95.8	72.6	75.8	75.8	-22.6		3.2		
R7	318.0	318.0	14/21	90.0	3.0	3.0		0.0	a7	3.0	8.0	V	1.5	100.0	14.1	-0.1		0.12	0.30	65.8	95.8	95.8	65.8	75.8	75.8	-29.4		10.0		
R8																														
R9	431.9	431.9	-4/22	0.0	3.0	3.0		0.0	a8	3.0	8.0	H	1.0	100.0	16.3	-0.1		0.12	0.30	77.4	100.8	100.8	77.4	80.8	80.8	-17.8		3.4		
R10	431.9	431.9	-4/22	90.0	3.0	3.0		0.0	a8	3.0	8.0	V	1.3	100.0	16.3	-0.1		0.12	0.30	75.5	100.8	100.8	75.5	80.8	80.8	-19.7		5.3		
R11	433.9	433.9	-4/22	0.0	3.0	3.0		0.0	a8	3.0	8.0	H	1.0	100.0	16.3	-0.1		0.12	0.30	78.6	100.8	100.8	78.6	80.8	80.8	-16.6		2.2		
R12	433.9	433.9	-4/22	90.0	3.0	3.0		0.0	a8	3.0	8.0	V	1.3	100.0	16.3	-0.1		0.12	0.30	77.4	100.8	100.8	77.4	80.8	80.8	-17.8		3.4		
R13	435.9	435.9	-4/22	0.0	3.0	3.0		0.0	a8	3.0	8.0	H	1.0	100.0	16.4	-0.1		0.12	0.30	78.4	100.9	100.9	78.4	80.9	80.9	-16.8		2.5		
R14	435.9	435.9	-4/22	90.0	3.0	3.0		0.0	a8	3.0	8.0	V	1.3	100.0	16.4	-0.1		0.12	0.30	76.5	100.9	100.9	76.5	80.9	80.9	-18.7		4.4		
R15																														
R16	868.3	868.3	8/51	0.0	3.0	3.0		0.0	a9	3.0	8.0	H	1.0	100.0	22.2	-0.2		0.12	0.30	80.2	101.9	101.9	80.2	81.9	81.9	-15.0		1.7		
R17	868.3	868.3	8/51	90.0	3.0	3.0		0.0	a9	3.0	8.0	V	1.1	100.0	22.2	-0.2		0.12	0.30	80.8	101.9	101.9	80.8	81.9	81.9	-14.4		1.1		
R18																														
R19	902.375	902.375	14/21	0.0	3.0	3.0		0.0	a10	3.0	8.0	H	1.0	100.0	22.6	-0.2		0.12	0.30	78.1	101.9	101.9	78.1	81.9	81.9	-21.2		3.8		
R20	902.375	902.375	14/21	90.0	3.0	3.0		0.0	a10	3.0	8.0	V	1.5	100.0	22.6	-0.2		0.12	0.30	76.0	101.9	101.9	76.0	81.9	81.9	-23.3		5.9		
R21	915.000	915.000	14/21	0.0	3.0	3.0		0.0	a10	3.0	8.0	H	1.0	100.0	22.7	-0.2		0.12	0.30	77.3	101.9	101.9	77.3	81.9	81.9	-22.0		4.6		
R22	915.000	915.000	14/21	90.0	3.0	3.0		0.0	a10	3.0	8.0	V	1.5	100.0	22.7	-0.2		0.12	0.30	75.0	101.9	101.9	75.0	81.9	81.9	-24.3		6.9		
R23	927.675	927.675	14/21	0.0	3.0	3.0		0.0	a10	3.0	8.0	H	1.0	100.0	22.9	-0.2		0.12	0.30	80.6	101.9	101.9	80.6	81.9	81.9	-18.7		1.3		
R24	927.675	927.675	14/21	90.0	3.0	3.0		0.0	a10	3.0	8.0	V	1.5	100.0	22.9	-0.2		0.12	0.30	78.6	101.9	101.9	78.6	81.9	81.9	-20.7		3.3		
R25																														
#	C1	C2	C3	C4	C5	C6	C7	C8	C9	C10	C11	C12	C13	C14	C15	C16	C17	C18	C19	C20	C21	C22	C23	C24	C25	C26	C27	C28	C29	

(ROW) (COLUMN) NOTE:
 R0 C5 MR is Measurement Range, which is reduced from DR to achieve necessary SNR.
 R0 C6 DR is the regulatory Desired Range measurement distance.
 R0 C7 N/F is Near-Field / Far-Field distance computed for max of EUT Antenna Dimension (C10) computed above 1 GHz.
 R0 C8 CF is computed using a 20 dB/decade Decay Rate.
 R0 C18/19 When E-field or EIRP is reported directly from Spectrum Analyzer, Antenna Factors and Cable losses are included directly in SA settings and Pr is not reported.

4.3 Unintentional Emissions

4.3.1 Transmit Chain Spurious Emissions

Test Setup & Procedure The test equipment and facilities were setup in accordance with the standards and procedures listed in Section 2.1. Environmental conditions were set at the appropriate temperature and thermal balance was checked with a thermocouple based probe. Spurious radiated emissions measurements are performed to 10 times the highest fundamental operating frequency. The test equipment employed includes RSFSV30001, LOGEMCO01, HQR1TO18S01.

Measurement Results The details and results of testing the EUT are summarized in Table 7.

Table 7(a): Transmit Chain Spurious Emissions.

EUT Modes: a1 315 BAND - 15.9 DB DUTY - MAX POWER (0x73) a5
 a2 a6
 Test Date(s): 2/1, 2/4, 3/12, 3/20/2019 a3
 Test Engineer: J. Brunett a4 a7 a8

R0	Frequency		Temp. (C) Hum. %	Table Angle deg	Site				EUT				Test Antenna				Cable Kg	Receiver			Field Strength @ DR						EIRP	Details	
	Start MHz	Stop MHz			MR	DR	N/F	CF	Mode see table	Volt. (V)	Dim cm	Pol. H/V	Ant. Height m	Dim. cm	Ka dB/m	Rx Power Pk		Bandwidth RBW	VBW	Pk Limit		Opk / Avg Limit		Calc. dBm	Worst Case Orient				
	Meas.	Limit USA			Limit CAN	Calc. dBuV/m	Limit USA	Limit CAN	Calc. dBm	Pass Fail dB																			
R1	SETUP				OATSC				PCB ONLY				EMCOLOG				CAB001	RSFSV30001			NOTES: H-POL - FLAT, V-POL END Worst Case Orient								
R2	624.0	624.0	-4/22	0.0	3.0	3.0		0.0	a1	3.0	8.0	H	1.2	100.0	10.4	-0.1			0.12	0.30	44.9	75.4	75.4	29.0	55.4	55.4	-50.3		26.4
R3	624.0	624.0	-4/22	90.0	3.0	3.0		0.0	a1	3.0	8.0	V	1.4	100.0	10.4	-0.1			0.12	0.30	40.9	75.4	75.4	25.0	55.4	55.4	-54.3		30.4
R4	936.0	936.0	-4/22	0.0	3.0	3.0		0.0	a1	3.0	8.0	H	1.0	100.0	16.5	-0.2			0.12	0.30	45.7	75.4	75.4	29.8	55.4	55.4	-49.5		25.6
R5	936.0	936.0	-4/22	90.0	3.0	3.0		0.0	a1	3.0	8.0	V	1.1	100.0	16.5	-0.2			0.12	0.30	44.7	75.4	75.4	28.8	55.4	55.4	-50.5		26.6
R6	SETUP				OATSC				PCB ONLY				EMCOLOG				CAB001	RSFSV30001			NOTES: max all orientations of EUT								
R7	SETUP				OATSC				PCB ONLY				EMCOLOG				CAB015	RSFSV30001			NOTES: max all orientations of EUT								
R8	1248.0	1248.0	-4/22	all	3.0	3.0	0.2	0.0	a1	3.0	8.0	H/V	all	15.0	21.3	-2.8			1.00	3.00	54.3	74.0	74.0	38.4	54.0	54.0	-40.9		15.6
R9	1560.0	1560.0	-4/22	all	3.0	3.0	0.2	0.0	a1	3.0	8.0	H/V	all	15.0	25.0	-3.2			1.00	3.00	51.2	74.0	74.0	35.3	54.0	54.0	-44.0		18.7
R10	1872.0	1872.0	-4/22	all	3.0	3.0	0.3	0.0	a1	3.0	8.0	H/V	all	15.0	27.7	-3.6			1.00	3.00	43.4	74.0	74.0	27.5	54.0	54.0	-51.8		26.5
R11	2184.0	2184.0	-4/22	all	3.0	3.0	0.3	0.0	a1	3.0	8.0	H/V	all	15.0	29.6	-3.9			1.00	3.00	41.7	74.0	74.0	25.8	54.0	54.0	-53.5		28.2
R12	2496.0	2496.0	-4/22	all	3.0	3.0	0.4	0.0	a1	3.0	8.0	H/V	all	15.0	30.8	-4.3			1.00	3.00	41.4	74.0	74.0	25.5	54.0	54.0	-53.8		28.5
R13	2808.0	2808.0	-4/22	all	3.0	3.0	0.4	0.0	a1	3.0	8.0	H/V	all	15.0	31.5	-4.7			1.00	3.00	40.0	74.0	74.0	24.1	54.0	54.0	-55.2		29.9
R14	3120.0	3120.0	-4/22	all	3.0	3.0	0.5	0.0	a1	4.0	8.0	H/V	all	15.0	31.8	-5.0			1.00	3.00	38.2	74.0	74.0	22.3	54.0	54.0	-57.0		31.7
R15	SETUP				OATSC				PCB ONLY				EMCOLOG				CAB001	RSFSV30001			NOTES: H-POL - FLAT, V-POL END Worst Case Orient								
R16	SETUP				OATSC				PCB ONLY				EMCOLOG				CAB001	RSFSV30001			NOTES: H-POL - FLAT, V-POL END Worst Case Orient								
R17	630.0	630.0	-4/22	0.0	3.0	3.0		0.0	a1	3.0	8.0	H	1.2	100.0	19.5	-0.1			0.12	0.30	47.4	75.6	75.6	31.5	55.6	55.6	-51.9		24.1
R18	630.0	630.0	-4/22	90.0	3.0	3.0		0.0	a1	3.0	8.0	V	1.4	100.0	19.5	-0.1			0.12	0.30	41.1	75.6	75.6	25.2	55.6	55.6	-58.2		30.4
R19	945.0	945.0	-4/22	0.0	3.0	3.0		0.0	a1	3.0	8.0	H	1.0	100.0	23.2	-0.2			0.12	0.30	50.6	75.6	75.6	34.7	55.6	55.6	-44.6		20.9
R20	945.0	945.0	-4/22	90.0	3.0	3.0		0.0	a1	3.0	8.0	H	1.1	100.0	23.2	-0.2			0.12	0.30	49.0	75.6	75.6	33.1	55.6	55.6	-46.2		22.5
R21	SETUP				OATSC				PCB ONLY				EMCOLOG				CAB015	RSFSV30001			NOTES: max all orientations of EUT								
R22	SETUP				OATSC				PCB ONLY				EMCOLOG				CAB015	RSFSV30001			NOTES: max all orientations of EUT								
R23	1260.0	1260.0	-4/22	all	3.0	3.0	0.2	0.0	a1	3.0	8.0	H/V	all	15.0	21.5	-2.8			1.00	3.00	55.1	74.0	74.0	39.2	54.0	54.0	-40.1		14.8
R24	1575.0	1575.0	-4/22	all	3.0	3.0	0.2	0.0	a1	3.0	8.0	H/V	all	15.0	25.2	-3.2			1.00	3.00	49.7	74.0	74.0	33.8	54.0	54.0	-45.5		20.2
R25	1890.0	1890.0	-4/22	all	3.0	3.0	0.3	0.0	a1	3.0	8.0	H/V	all	15.0	27.9	-3.6			1.00	3.00	44.9	74.0	74.0	29.0	54.0	54.0	-50.3		25.0
R26	2205.0	2205.0	-4/22	all	3.0	3.0	0.3	0.0	a1	3.0	8.0	H/V	all	15.0	29.7	-4.0			1.00	3.00	43.6	74.0	74.0	27.7	54.0	54.0	-51.6		26.3
R27	2520.0	2520.0	-4/22	all	3.0	3.0	0.4	0.0	a1	3.0	8.0	H/V	all	15.0	30.9	-4.3			1.00	3.00	42.3	74.0	74.0	26.4	54.0	54.0	-52.9		27.6
R28	2835.0	2835.0	-4/22	all	3.0	3.0	0.4	0.0	a1	4.0	8.0	H/V	all	15.0	31.6	-4.7			1.00	3.00	42.9	74.0	74.0	27.0	54.0	54.0	-52.3		27.0
R29	3150.0	3150.0	-4/22	all	3.0	3.0	0.5	0.0	a1	4.0	8.0	H/V	all	15.0	31.8	-5.0			1.00	3.00	39.5	74.0	74.0	23.6	54.0	54.0	-55.7		30.4
R30	SETUP				OATSC				PCB ONLY				EMCOLOG				CAB001	RSFSV30001			NOTES: H-POL - FLAT, V-POL END Worst Case Orient								
R31	SETUP				OATSC				PCB ONLY				EMCOLOG				CAB001	RSFSV30001			NOTES: H-POL - FLAT, V-POL END Worst Case Orient								
R32	636.0	636.0	-4/22	0.0	3.0	3.0		0.0	a1	3.0	8.0	H	1.2	100.0	10.7	-0.1			0.12	0.30	42.1	75.8	75.8	26.2	55.8	55.8	-53.1		29.6
R33	636.0	636.0	-4/22	90.0	3.0	3.0		0.0	a1	3.0	8.0	V	1.4	100.0	10.7	-0.1			0.12	0.30	37.0	75.8	75.8	21.1	55.8	55.8	-58.2		34.7
R34	954.0	954.0	-4/22	0.0	3.0	3.0		0.0	a1	3.0	8.0	H	1.0	100.0	16.8	-0.2			0.12	0.30	49.7	75.8	75.8	33.8	55.8	55.8	-45.5		22.0
R35	954.0	954.0	-4/22	90.0	3.0	3.0		0.0	a1	3.0	8.0	V	1.1	100.0	16.8	-0.2			0.12	0.30	48.0	75.8	75.8	32.1	55.8	55.8	-47.2		23.7
R36	SETUP				OATSC				PCB ONLY				EMCOLOG				CAB015	RSFSV30001			NOTES: max all orientations of EUT								
R37	SETUP				OATSC				SAMPLE A				EMCOLOG				CAB015	RSFSV30001			NOTES: max all orientations of EUT								
R38	1272.0	1272.0	-4/22	all	3.0	3.0	0.2	0.0	a1	3.0	8.0	H/V	all	15.0	21.7	-2.9			1.00	3.00	57.7	74.0	74.0	41.8	54.0	54.0	-37.5		12.2
R39	1590.0	1590.0	-4/22	all	3.0	3.0	0.2	0.0	a1	3.0	8.0	H/V	all	15.0	25.3	-3.2			1.00	3.00	48.2	74.0	74.0	32.3	54.0	54.0	-47.0		21.7
R40	1908.0	1908.0	-4/22	all	3.0	3.0	0.3	0.0	a1	3.0	8.0	H/V	all	15.0	28.0	-3.6			1.00	3.00	44.7	74.0	74.0	28.8	54.0	54.0	-50.5		25.2
R41	2226.0	2226.0	-4/22	all	3.0	3.0	0.3	0.0	a1	3.0	8.0	H/V	all	15.0	29.8	-4.0			1.00	3.00	43.2	74.0	74.0	27.3	54.0	54.0	-52.0		26.7
R42	2544.0	2544.0	-4/22	all	3.0	3.0	0.4	0.0	a1	3.0	8.0	H/V	all	15.0	31.0	-4.4			1.00	3.00	42.0	74.0	74.0	26.1	54.0	54.0	-53.2		27.9
R43	2862.0	2862.0	-4/22	all	3.0	3.0	0.4	0.0	a1	3.0	8.0	H/V	all	15.0	31.6	-4.7			1.00	3.00	43.3	74.0	74.0	27.4	54.0	54.0	-51.9		26.6
R44	3180.0	3180.0	-4/22	all	3.0	3.0	0.5	0.0	a2	3.0	8.0	H/V	all	16.0	31.9	-5.1			1.00	3.00	38.4	74.0	74.0	22.5	54.0	54.0	-56.8		31.5
R45	SETUP				OATSC				PCB ONLY				EMCOLOG				CAB015	RSFSV30001			NOTES: max all orientations of EUT								

(ROW) (COLUMN)

- R0 C5 MR is Measurement Range, which is reduced from DR to achieve necessary SNR.
- R0 C6 DR is the regulatory Desired Range measurement distance.
- R0 C7 N/F is Near-Field / Far-Field distance computed for max of EUT Antenna Dimension (C10) computed above 1 GHz.
- R0 C8 CF is computed using a 20 dB/decade Decay Rate.
- R0 C18/19 When E-field or EIRP is reported directly from Spectrum Analyzer, Antenna Factors and Cable losses are included directly in SA settings and Pr is not reported.

Table 7(b): Transmit Chain Spurious Emissions.

EUT Modes: a4 315 BAND - 7.9 DB DUTY - MID POWER (0x53) a8
 a5 a9
 Test Date(s): 2/1, 2/4, 3/12, 3/20/2019 a6 a10
 Test Engineer: J. Brunett a7 a11

R0	Frequency		Temp. (C) Hum. %	Table Angle deg	Site				EUT			Test Antenna				Cable Kg	Receiver				Field Strength @ DR					EIRP Calc. dBm	Details Pass Fail dB		
	Start MHz	Stop MHz			MR	DR	N/F	CF	Mode	Volt. (V)	Dim cm	Pol. H/V	Ant. Height m	Dim. cm	Ka dB/m		Rx Power Pk	Bandwidth Avg	RBW MHz	VBW	Meas.	Limit USA	Limit CAN	Calc. dBuV/m	Limit USA			Limit CAN	
	MHz	MHz			m	m		dB	table			H/V	m	cm			dBm	MHz	MHz			USA	CAN	USA	CAN				
R1	SETUP				OATSC				PCB ONLY			EMCOLOG				CAB001	RSFSV30001				NOTES: H-POL - FLAT, V-POL END Worst Case Orient								
R2	624.0	624.0	-4/22	0.0	3.0	3.0		0.0	a4	3.0	8.0	H	1.2	100.0	10.4	-0.1		0.12	0.30	35.9	75.4	75.4	28.0	55.4	55.4	-59.3		27.4	
R3	624.0	624.0	-4/22	90.0	3.0	3.0		0.0	a4	3.0	8.0	V	1.4	100.0	10.4	-0.1		0.12	0.30	37.9	75.4	75.4	30.0	55.4	55.4	-57.3		25.4	
R4	936.0	936.0	-4/22	0.0	3.0	3.0		0.0	a4	3.0	8.0	H	1.0	100.0	16.5	-0.2		0.12	0.30	39.2	75.4	75.4	31.3	55.4	55.4	-56.0		24.1	
R5	936.0	936.0	-4/22	90.0	3.0	3.0		0.0	a4	3.0	8.0	V	1.1	100.0	16.5	-0.2		0.12	0.30	38.4	75.4	75.4	30.5	55.4	55.4	-56.8		24.9	
R6																													
R7	SETUP				OATSC				PCB ONLY			EMCOLOG				CAB015	RSFSV30001				NOTES: max all orientations of EUT								
R8	1248.0	1248.0	-4/22	all	3.0	3.0	0.2	0.0	a4	3.0	8.0	H/V	all	15.0	21.3	-2.8		1.00	3.00	44.5	74.0	74.0	36.6	54.0	54.0	-50.7		17.4	
R9	1560.0	1560.0	-4/22	all	3.0	3.0	0.2	0.0	a4	3.0	8.0	H/V	all	15.0	25.0	-3.2		1.00	3.00	44.0	74.0	74.0	36.1	54.0	54.0	-51.2		17.9	
R10	1872.0	1872.0	-4/22	all	3.0	3.0	0.3	0.0	a4	3.0	8.0	H/V	all	15.0	27.7	-3.6		1.00	3.00	38.1	74.0	74.0	30.2	54.0	54.0	-57.1		23.8	
R11	2184.0	2184.0	-4/22	all	3.0	3.0	0.3	0.0	a4	3.0	8.0	H/V	all	15.0	29.6	-3.9		1.00	3.00	37.1	74.0	74.0	29.2	54.0	54.0	-58.1		24.8	
R12	2496.0	2496.0	-4/22	all	3.0	3.0	0.4	0.0	a4	3.0	8.0	H/V	all	15.0	30.8	-4.3		1.00	3.00	36.9	74.0	74.0	29.0	54.0	54.0	-58.3		25.0	
R13	2808.0	2808.0	-4/22	all	3.0	3.0	0.4	0.0	a4	3.0	8.0	H/V	all	15.0	31.5	-4.7		1.00	3.00	37.5	74.0	74.0	29.6	54.0	54.0	-57.7		24.4	
R14	3120.0	3120.0	-4/22	all	3.0	3.0	0.5	0.0	a4	4.0	8.0	H/V	all	15.0	31.8	-5.0		1.00	3.00	38.0	74.0	74.0	30.1	54.0	54.0	-57.2		23.9	
R15																													
R16	SETUP				OATSC				PCB ONLY			EMCOLOG				CAB001	RSFSV30001				NOTES: H-POL - FLAT, V-POL END Worst Case Orient								
R17	630.0	630.0	-4/22	0.0	3.0	3.0		0.0	a4	3.0	8.0	H	1.2	100.0	19.5	-0.1		0.12	0.30	38.1	75.6	75.6	30.2	55.6	55.6	-61.2		25.4	
R18	630.0	630.0	-4/22	90.0	3.0	3.0		0.0	a4	3.0	8.0	V	1.4	100.0	19.5	-0.1		0.12	0.30	38.9	75.6	75.6	31.0	55.6	55.6	-60.4		24.6	
R19	945.0	945.0	-4/22	0.0	3.0	3.0		0.0	a4	3.0	8.0	H	1.0	100.0	23.2	-0.2		0.12	0.30	39.9	75.6	75.6	32.0	55.6	55.6	-55.3		23.6	
R20	945.0	945.0	-4/22	90.0	3.0	3.0		0.0	a4	3.0	8.0	H	1.1	100.0	23.2	-0.2		0.12	0.30	40.3	75.6	75.6	32.4	55.6	55.6	-54.9		23.2	
R21																													
R22	SETUP				OATSC				PCB ONLY			EMCOLOG				CAB015	RSFSV30001				NOTES: max all orientations of EUT								
R23	1260.0	1260.0	-4/22	all	3.0	3.0	0.2	0.0	a4	3.0	8.0	H/V	all	15.0	21.5	-2.8		1.00	3.00	46.2	74.0	74.0	38.3	54.0	54.0	-49.0		15.7	
R24	1575.0	1575.0	-4/22	all	3.0	3.0	0.2	0.0	a4	3.0	8.0	H/V	all	15.0	25.2	-3.2		1.00	3.00	43.7	74.0	74.0	35.8	54.0	54.0	-51.5		18.2	
R25	1890.0	1890.0	-4/22	all	3.0	3.0	0.3	0.0	a4	3.0	8.0	H/V	all	15.0	27.9	-3.6		1.00	3.00	37.7	74.0	74.0	29.8	54.0	54.0	-57.5		24.2	
R26	2205.0	2205.0	-4/22	all	3.0	3.0	0.3	0.0	a4	3.0	8.0	H/V	all	15.0	29.7	-4.0		1.00	3.00	37.4	74.0	74.0	29.5	54.0	54.0	-57.8		24.5	
R27	2520.0	2520.0	-4/22	all	3.0	3.0	0.4	0.0	a4	3.0	8.0	H/V	all	15.0	30.9	-4.3		1.00	3.00	37.9	74.0	74.0	30.0	54.0	54.0	-57.3		24.0	
R28	2835.0	2835.0	-4/22	all	3.0	3.0	0.4	0.0	a4	4.0	8.0	H/V	all	15.0	31.6	-4.7		1.00	3.00	37.9	74.0	74.0	30.0	54.0	54.0	-57.3		24.0	
R29	3150.0	3150.0	-4/22	all	3.0	3.0	0.5	0.0	a4	4.0	8.0	H/V	all	15.0	31.8	-5.0		1.00	3.00	38.1	74.0	74.0	30.2	54.0	54.0	-57.1		23.8	
R30																													
R31	SETUP				OATSC				PCB ONLY			EMCOLOG				CAB001	RSFSV30001				NOTES: H-POL - FLAT, V-POL END Worst Case Orient								
R32	636.0	636.0	-4/22	0.0	3.0	3.0		0.0	a4	3.0	8.0	H	1.2	100.0	10.7	-0.1		0.12	0.30	38.0	75.8	75.8	30.1	55.8	55.8	-57.2		25.7	
R33	636.0	636.0	-4/22	90.0	3.0	3.0		0.0	a4	3.0	8.0	V	1.4	100.0	10.7	-0.1		0.12	0.30	34.5	75.8	75.8	26.6	55.8	55.8	-60.7		29.2	
R34	954.0	954.0	-4/22	0.0	3.0	3.0		0.0	a4	3.0	8.0	H	1.0	100.0	16.8	-0.2		0.12	0.30	33.9	75.8	75.8	26.0	55.8	55.8	-61.3		29.8	
R35	954.0	954.0	-4/22	90.0	3.0	3.0		0.0	a4	3.0	8.0	V	1.1	100.0	16.8	-0.2		0.12	0.30	38.0	75.8	75.8	30.1	55.8	55.8	-57.2		25.7	
R36																													
R37	SETUP				OATSC				SAMPLE A			EMCOLOG				CAB015	RSFSV30001				NOTES: max all orientations of EUT								
R38	1272.0	1272.0	-4/22	all	3.0	3.0	0.2	0.0	a4	3.0	8.0	H/V	all	15.0	21.7	-2.9		1.00	3.00	45.9	74.0	74.0	38.0	54.0	54.0	-49.3		16.0	
R39	1590.0	1590.0	-4/22	all	3.0	3.0	0.2	0.0	a4	3.0	8.0	H/V	all	15.0	25.3	-3.2		1.00	3.00	42.9	74.0	74.0	35.0	54.0	54.0	-52.3		19.0	
R40	1908.0	1908.0	-4/22	all	3.0	3.0	0.3	0.0	a4	3.0	8.0	H/V	all	15.0	28.0	-3.6		1.00	3.00	37.0	74.0	74.0	29.1	54.0	54.0	-58.2		24.9	
R41	2226.0	2226.0	-4/22	all	3.0	3.0	0.3	0.0	a4	3.0	8.0	H/V	all	15.0	29.8	-4.0		1.00	3.00	36.9	74.0	74.0	29.0	54.0	54.0	-58.3		25.0	
R42	2544.0	2544.0	-4/22	all	3.0	3.0	0.4	0.0	a4	3.0	8.0	H/V	all	15.0	31.0	-4.4		1.00	3.00	37.2	74.0	74.0	29.3	54.0	54.0	-58.0		24.7	
R43	2862.0	2862.0	-4/22	all	3.0	3.0	0.4	0.0	a4	3.0	8.0	H/V	all	15.0	31.6	-4.7		1.00	3.00	35.3	74.0	74.0	27.4	54.0	54.0	-59.9		26.6	
R44	3180.0	3180.0	-4/22	all	3.0	3.0	0.5	0.0	a4	3.0	8.0	H/V	all	16.0	31.9	-5.1		1.00	3.00	38.0	74.0	74.0	30.1	54.0	54.0	-57.2		23.9	
R45																													
#	C1	C2	C3	C4	C5	C6	C7	C8	C9	C10	C11	C12	C13	C14	C15	C16	C17	C18	C19	C20	C21	C22	C23	C24	C25	C26	C27	C28	C29

(ROW) (COLUMN) NOTE:
 R0 C5 MR is Measurement Range, which is reduced from DR to achieve necessary SNR.
 R0 C6 DR is the regulatory Desired Range measurement distance.
 R0 C7 N/F is Near-Field / Far-Field distance computed for max of EUT Antenna Dimension (C10) computed above 1 GHz.
 R0 C8 CF is computed using a 20 dB/decade Decay Rate.
 R0 C18/19 When E-field or EIRP is reported directly from Spectrum Analyzer, Antenna Factors and Cable losses are included directly in SA settings and Pr is not reported.

Table 7(c): Transmit Chain Spurious Emissions.

EUT Modes: a7 315 BAND - 0 DB DUTY - MIN POWER (0x33) a11
 a8 a12
 Test Date(s): 2/1, 2/4, 3/12, 3/20/2019 a9 a13
 Test Engineer: J. Brunett a10 a14

R0	Frequency		Temp. (C) Hum. %	Table Angle deg	Site				EUT				Test Antenna				Cable Kg dB	Receiver				Field Strength @ DR						EIRP Calc. dBm	Details Pass Fail dB		
	Start MHz	Stop MHz			MR	DR	N/F	CF	Mode see table	Volt. (V)	Dim cm	Pol. H/V	Ant. Height m	Dim. cm	Ka dB/m	Rx Power Pk dBm		Avg	Bandwidth RBW MHz	VBW	Meas.	Limit USA	CAN	Calc.	Limit USA	CAN	Calc.			Limit USA	CAN
	MHz	MHz			m	m		dB				H/V	m	cm	dB/m				MHz		dBuV/m										
R1	SETUP				OATSC				PCB ONLY				EMCOLOG				CAB001	RSFSV30001				NOTES: H-POL - FLAT, V-POL END Worst Case Orient									
R2	624.0	624.0	-4/22	0.0	3.0	3.0		0.0	a7	3.0	8.0	H	1.2	100.0	10.4	-0.1		0.12	0.30	38.1	75.4	75.4	38.1	55.4	55.4	-57.1		17.3			
R3	624.0	624.0	-4/22	90.0	3.0	3.0		0.0	a7	3.0	8.0	V	1.4	100.0	10.4	-0.1		0.12	0.30	34.7	75.4	75.4	34.7	55.4	55.4	-60.5		20.7			
R4	936.0	936.0	-4/22	0.0	3.0	3.0		0.0	a7	3.0	8.0	H	1.0	100.0	16.5	-0.2		0.12	0.30	34.1	75.4	75.4	34.1	55.4	55.4	-61.1		21.3			
R5	936.0	936.0	-4/22	90.0	3.0	3.0		0.0	a7	3.0	8.0	V	1.1	100.0	16.5	-0.2		0.12	0.30	38.2	75.4	75.4	38.2	55.4	55.4	-57.0		17.2			
R6																															
R7	SETUP				OATSC				PCB ONLY				EMCOLOG				CAB015	RSFSV30001				NOTES: max all orientations of EUT									
R8	1248.0	1248.0	-4/22	all	3.0	3.0	0.2	0.0	a7	3.0	8.0	H/V	all	15.0	21.3	-2.8		1.00	3.00	40.2	74.0	74.0	40.2	54.0	54.0	-55.0		13.8			
R9	1560.0	1560.0	-4/22	all	3.0	3.0	0.2	0.0	a7	3.0	8.0	H/V	all	15.0	25.0	-3.2		1.00	3.00	40.0	74.0	74.0	40.0	54.0	54.0	-55.2		14.0			
R10	1872.0	1872.0	-4/22	all	3.0	3.0	0.3	0.0	a7	3.0	8.0	H/V	all	15.0	27.7	-3.6		1.00	3.00	36.3	74.0	74.0	36.3	54.0	54.0	-58.9		17.7			
R11	2184.0	2184.0	-4/22	all	3.0	3.0	0.3	0.0	a7	3.0	8.0	H/V	all	15.0	29.6	-3.9		1.00	3.00	37.8	74.0	74.0	37.8	54.0	54.0	-57.4		16.2			
R12	2496.0	2496.0	-4/22	all	3.0	3.0	0.4	0.0	a7	3.0	8.0	H/V	all	15.0	30.8	-4.3		1.00	3.00	37.8	74.0	74.0	37.8	54.0	54.0	-57.4		16.2			
R13	2808.0	2808.0	-4/22	all	3.0	3.0	0.4	0.0	a7	3.0	8.0	H/V	all	15.0	31.5	-4.7		1.00	3.00	39.0	74.0	74.0	39.0	54.0	54.0	-56.2		15.0			
R14	3120.0	3120.0	-4/22	all	3.0	3.0	0.5	0.0	a7	4.0	8.0	H/V	all	15.0	31.8	-5.0		1.00	3.00	37.4	74.0	74.0	37.4	54.0	54.0	-57.8		16.6			
R15																															
R16	SETUP				OATSC				PCB ONLY				EMCOLOG				CAB001	RSFSV30001				NOTES: H-POL - FLAT, V-POL END Worst Case Orient									
R17	630.0	630.0	-4/22	0.0	3.0	3.0		0.0	a7	3.0	8.0	H	1.2	100.0	19.5	-0.1		0.12	0.30	38.2	75.6	75.6	38.2	55.6	55.6	-61.1		17.4			
R18	630.0	630.0	-4/22	90.0	3.0	3.0		0.0	a7	3.0	8.0	V	1.4	100.0	19.5	-0.1		0.12	0.30	35.0	75.6	75.6	35.0	55.6	55.6	-64.3		20.6			
R19	945.0	945.0	-4/22	0.0	3.0	3.0		0.0	a7	3.0	8.0	H	1.0	100.0	23.2	-0.2		0.12	0.30	36.7	75.6	75.6	36.7	55.6	55.6	-58.5		18.9			
R20	945.0	945.0	-4/22	90.0	3.0	3.0		0.0	a7	3.0	8.0	H	1.1	100.0	23.2	-0.2		0.12	0.30	38.0	75.6	75.6	38.0	55.6	55.6	-57.2		17.6			
R21																															
R22	SETUP				OATSC				PCB ONLY				EMCOLOG				CAB015	RSFSV30001				NOTES: max all orientations of EUT									
R23	1260.0	1260.0	-4/22	all	3.0	3.0	0.2	0.0	a7	3.0	8.0	H/V	all	15.0	21.5	-2.8		1.00	3.00	41.2	74.0	74.0	41.2	54.0	54.0	-54.0		12.8			
R24	1575.0	1575.0	-4/22	all	3.0	3.0	0.2	0.0	a7	3.0	8.0	H/V	all	15.0	25.2	-3.2		1.00	3.00	40.6	74.0	74.0	40.6	54.0	54.0	-54.6		13.4			
R25	1890.0	1890.0	-4/22	all	3.0	3.0	0.3	0.0	a7	3.0	8.0	H/V	all	15.0	27.9	-3.6		1.00	3.00	34.8	74.0	74.0	34.8	54.0	54.0	-60.4		19.2			
R26	2205.0	2205.0	-4/22	all	3.0	3.0	0.3	0.0	a7	3.0	8.0	H/V	all	15.0	29.7	-4.0		1.00	3.00	35.9	74.0	74.0	35.9	54.0	54.0	-59.3		18.1			
R27	2520.0	2520.0	-4/22	all	3.0	3.0	0.4	0.0	a7	3.0	8.0	H/V	all	15.0	30.9	-4.3		1.00	3.00	40.1	74.0	74.0	40.1	54.0	54.0	-55.1		13.9			
R28	2835.0	2835.0	-4/22	all	3.0	3.0	0.4	0.0	a7	4.0	8.0	H/V	all	15.0	31.6	-4.7		1.00	3.00	37.4	74.0	74.0	37.4	54.0	54.0	-57.8		16.6			
R29	3150.0	3150.0	-4/22	all	3.0	3.0	0.5	0.0	a7	4.0	8.0	H/V	all	15.0	31.8	-5.0		1.00	3.00	37.6	74.0	74.0	37.6	54.0	54.0	-57.6		16.4			
R30																															
R31	SETUP				OATSC				PCB ONLY				EMCOLOG				CAB001	RSFSV30001				NOTES: H-POL - FLAT, V-POL END Worst Case Orient									
R32	636.0	636.0	-4/22	0.0	3.0	3.0		0.0	a7	3.0	8.0	H	1.2	100.0	10.7	-0.1		0.12	0.30	39.1	75.8	75.8	39.1	55.8	55.8	-56.1		16.7			
R33	636.0	636.0	-4/22	90.0	3.0	3.0		0.0	a7	3.0	8.0	V	1.4	100.0	10.7	-0.1		0.12	0.30	36.0	75.8	75.8	36.0	55.8	55.8	-59.2		19.8			
R34	954.0	954.0	-4/22	0.0	3.0	3.0		0.0	a7	3.0	8.0	H	1.0	100.0	16.8	-0.2		0.12	0.30	37.1	75.8	75.8	37.1	55.8	55.8	-58.1		18.7			
R35	954.0	954.0	-4/22	90.0	3.0	3.0		0.0	a7	3.0	8.0	V	1.1	100.0	16.8	-0.2		0.12	0.30	35.9	75.8	75.8	35.9	55.8	55.8	-59.3		19.9			
R36																															
R37	SETUP				OATSC				SAMPLE A				EMCOLOG				CAB015	RSFSV30001				NOTES: max all orientations of EUT									
R38	1272.0	1272.0	-4/22	all	3.0	3.0	0.2	0.0	a7	3.0	8.0	H/V	all	15.0	21.7	-2.9		1.00	3.00	41.1	74.0	74.0	41.1	54.0	54.0	-54.1		12.9			
R39	1590.0	1590.0	-4/22	all	3.0	3.0	0.2	0.0	a7	3.0	8.0	H/V	all	15.0	25.3	-3.2		1.00	3.00	40.4	74.0	74.0	40.4	54.0	54.0	-54.8		13.6			
R40	1908.0	1908.0	-4/22	all	3.0	3.0	0.3	0.0	a7	3.0	8.0	H/V	all	15.0	28.0	-3.6		1.00	3.00	38.0	74.0	74.0	38.0	54.0	54.0	-57.2		16.0			
R41	2226.0	2226.0	-4/22	all	3.0	3.0	0.3	0.0	a7	3.0	8.0	H/V	all	15.0	29.8	-4.0		1.00	3.00	36.9	74.0	74.0	36.9	54.0	54.0	-58.3		17.1			
R42	2544.0	2544.0	-4/22	all	3.0	3.0	0.4	0.0	a7	3.0	8.0	H/V	all	15.0	31.0	-4.4		1.00	3.00	37.0	74.0	74.0	37.0	54.0	54.0	-58.2		17.0			
R43	2862.0	2862.0	-4/22	all	3.0	3.0	0.4	0.0	a7	3.0	8.0	H/V	all	15.0	31.6	-4.7		1.00	3.00	36.7	74.0	74.0	36.7	54.0	54.0	-58.5		17.3			
R44	3180.0	3180.0	-4/22	all	3.0	3.0	0.5	0.0	a7	3.0	8.0	H/V	all	16.0	31.9	-5.1		1.00	3.00	38.9	74.0	74.0	38.9	54.0	54.0	-56.3		15.1			
R45																															
#	C1	C2	C3	C4	C5	C6	C7	C8	C9	C10	C11	C12	C13	C14	C15	C16	C17	C18	C19	C20	C21	C22	C23	C24	C25	C26	C27	C28	C29		

(ROW) (COLUMN) NOTE:
 R0 C5 MR is Measurement Range, which is reduced from DR to achieve necessary SNR.
 R0 C6 DR is the regulatory Desired Range measurement distance.
 R0 C7 N/F is Near-Field / Far-Field distance computed for max of EUT Antenna Dimension (C10) computed above 1 GHz.
 R0 C8 CF is computed using a 20 dB/decade Decay Rate.
 R0 C18/19 When E-field or EIRP is reported directly from Spectrum Analyzer, Antenna Factors and Cable losses are included directly in SA settings and Pr is not reported.

Table 7(d): Transmit Chain Spurious Emissions.

EUT Modes: a1 a5
 a2 434 BAND - 14 DB DUTY - MAX POWER (0x73) a6
 Test Date(s): 2/1, 2/4, 3/12, 3/20/2019 a3 a7
 Test Engineer: J. Brunett a4 a8

R0	Frequency		Site					EUT			Test Antenna				Cable		Receiver		Field Strength @ DR					EIRP		Details		
	Start	Stop	Temp. (C)	Table Angle	MR	DR	N/F	CF	Mode	Volt.	Dim	Pol.	Ant. Height	Dim.	Ka	Kg	Rx Power Pk	Bandwidth Avg	Meas.	Limit	Calc.	Qpk / Avg	Limit	Calc.	Calc.	Pass		
	MHz	MHz	Hum.	deg	m	m		dB	see table	(V)	cm	H/V	m	cm	dB/m	dB	dBm	MHz	dBuV/m	USA	CAN	USA	CAN	dBm	Fail			
R1	SETUP		OATSC					PCB ONLY			EMCOLOG				CAB001		RSFSV30001		NOTES: H-POL - FLAT, V-POL END Worst Case Orient									
R2	866.4	866.4	-4 / 22	0.0	3.0	3.0		0.0	a2	3.0	8.0	H	1.0	100.0	15.3	-0.2		0.12	0.30	57.2	80.8	80.8	43.2	60.8	60.8	-38.0		17.6
R3	866.4	866.4	-4 / 22	90.0	3.0	3.0		0.0	a2	3.0	8.0	V	1.1	100.0	15.3	-0.2		0.12	0.30	54.1	80.8	80.8	40.1	60.8	60.8	-41.1		20.7
R4	SETUP		OATSC					PCB ONLY			HRNSINGQR				CAB015		RSFSV30001		NOTES: max all orientations of EUT									
R5	1299.6	1299.6	-4 / 22	all	3.0	3.0	0.2	0.0	a2	3.0	8.0	H/V	all	15.0	22.0	-2.9		1.00	3.00	59.3	74.0	74.0	45.3	54.0	54.0	-35.9		8.7
R6	1732.8	1732.8	-4 / 22	all	3.0	3.0	0.3	0.0	a2	3.0	8.0	H/V	all	15.0	26.6	-3.4		1.00	3.00	47.0	74.0	74.0	33.0	54.0	54.0	-48.2		21.0
R7	2166.0	2166.0	-4 / 22	all	3.0	3.0	0.3	0.0	a2	3.0	8.0	H/V	all	15.0	29.5	-3.9		1.00	3.00	47.4	74.0	74.0	33.4	54.0	54.0	-47.8		20.6
R8	2599.2	2599.2	-4 / 22	all	3.0	3.0	0.4	0.0	a2	3.0	8.0	H/V	all	15.0	31.1	-4.4		1.00	3.00	44.2	74.0	74.0	30.2	54.0	54.0	-51.0		23.8
R9	3032.4	3032.4	-4 / 22	all	3.0	3.0	0.5	0.0	a2	3.0	8.0	H/V	all	15.0	31.8	-4.9		1.00	3.00	44.2	74.0	74.0	30.2	54.0	54.0	-51.0		23.8
R10	3465.6	3465.6	-4 / 22	all	3.0	3.0	0.5	0.0	a2	3.0	8.0	H/V	all	15.0	31.9	-5.4		1.00	3.00	43.0	74.0	74.0	29.0	54.0	54.0	-52.2		25.0
R11	3898.8	3898.8	-4 / 22	all	3.0	3.0	0.6	0.0	a2	3.0	8.0	H/V	all	15.0	32.0	-5.9		1.00	3.00	45.7	74.0	74.0	31.7	54.0	54.0	-49.5		22.3
R12	4332.0	4332.0	-4 / 22	all	3.0	3.0	0.6	0.0	a2	4.0	8.0	H/V	all	15.0	32.3	-6.3		1.00	3.00	41.7	74.0	74.0	27.7	54.0	54.0	-53.5		26.3
R13	SETUP		OATSC					PCB ONLY			EMCOLOG				CAB001		RSFSV30001		NOTES: H-POL - FLAT, V-POL END Worst Case Orient									
R15	867.8	867.8	-4 / 22	0.0	3.0	3.0		0.0	a2	3.0	8.0	H	1.0	100.0	22.2	-0.2		0.12	0.30	53.5	80.8	80.8	39.5	60.8	60.8	-45.8		21.3
R16	867.8	867.8	-4 / 22	90.0	3.0	3.0		0.0	a2	3.0	8.0	V	1.1	100.0	22.2	-0.2		0.12	0.30	48.2	80.8	80.8	34.2	60.8	60.8	-51.1		26.6
R17	SETUP		OATSC					PCB ONLY			EMCOLOG				CAB015		RSFSV30001		NOTES: max all orientations of EUT									
R18	1301.7	1301.7	-4 / 22	all	3.0	3.0	0.2	0.0	a2	3.0	8.0	H/V	all	15.0	22.0	-2.9		1.00	3.00	58.8	74.0	74.0	44.8	54.0	54.0	-36.4		9.2
R19	1735.6	1735.6	-4 / 22	all	3.0	3.0	0.3	0.0	a2	3.0	8.0	H/V	all	15.0	26.7	-3.4		1.00	3.00	48.4	74.0	74.0	34.4	54.0	54.0	-46.8		19.6
R20	2169.5	2169.5	-4 / 22	all	3.0	3.0	0.3	0.0	a2	3.0	8.0	H/V	all	15.0	29.6	-3.9		1.00	3.00	45.0	74.0	74.0	31.0	54.0	54.0	-50.2		23.0
R21	2603.4	2603.4	-4 / 22	all	3.0	3.0	0.4	0.0	a2	3.0	8.0	H/V	all	15.0	31.1	-4.4		1.00	3.00	44.3	74.0	74.0	30.3	54.0	54.0	-50.9		23.7
R22	3037.3	3037.3	-4 / 22	all	3.0	3.0	0.5	0.0	a2	3.0	8.0	H/V	all	15.0	31.8	-4.9		1.00	3.00	44.0	74.0	74.0	30.0	54.0	54.0	-51.2		24.0
R23	3471.2	3471.2	-4 / 22	all	3.0	3.0	0.5	0.0	a2	3.0	8.0	H/V	all	15.0	31.9	-5.4		1.00	3.00	41.4	74.0	74.0	27.4	54.0	54.0	-53.8		26.6
R24	3905.1	3905.1	-4 / 22	all	3.0	3.0	0.6	0.0	a2	3.0	8.0	H/V	all	15.0	32.0	-5.9		1.00	3.00	43.8	74.0	74.0	29.8	54.0	54.0	-51.4		24.2
R25	4339.0	4339.0	-4 / 22	all	3.0	3.0	0.7	0.0	a2	4.0	8.0	H/V	all	15.0	32.3	-6.3		1.00	3.00	42.0	74.0	74.0	28.0	54.0	54.0	-53.2		26.0
R26	SETUP		OATSC					PCB ONLY			EMCOLOG				CAB001		RSFSV30001		NOTES: H-POL - FLAT, V-POL END Worst Case Orient									
R28	869.2	869.2	-4 / 22	0.0	3.0	3.0		0.0	a2	3.0	8.0	H	1.0	100.0	22.2	-0.2		0.12	0.30	57.0	80.9	80.9	43.0	60.9	60.9	-42.3		17.9
R29	869.2	869.2	-4 / 22	90.0	3.0	3.0		0.0	a2	3.0	8.0	V	1.1	100.0	22.2	-0.2		0.12	0.30	51.2	80.9	80.9	37.2	60.9	60.9	-48.1		23.7
R30	SETUP		OATSC					PCB ONLY			EMCOLOG				CAB015		RSFSV30001		NOTES: max all orientations of EUT									
R31	1303.1	1303.1	-4 / 22	all	3.0	3.0	0.2	0.0	a2	3.0	8.0	H/V	all	15.0	22.1	-2.9		1.00	3.00	57.6	74.0	74.0	43.6	54.0	54.0	-37.6		10.4
R32	1737.0	1737.0	-4 / 22	all	3.0	3.0	0.3	0.0	a2	3.0	8.0	H/V	all	15.0	26.7	-3.4		1.00	3.00	47.8	74.0	74.0	33.8	54.0	54.0	-47.4		20.2
R33	2170.9	2170.9	-4 / 22	all	3.0	3.0	0.3	0.0	a2	3.0	8.0	H/V	all	15.0	29.6	-3.9		1.00	3.00	45.8	74.0	74.0	31.8	54.0	54.0	-49.4		22.2
R34	2604.8	2604.8	-4 / 22	all	3.0	3.0	0.4	0.0	a2	3.0	8.0	H/V	all	15.0	31.1	-4.4		1.00	3.00	45.2	74.0	74.0	31.2	54.0	54.0	-50.0		22.8
R35	3038.7	3038.7	-4 / 22	all	3.0	3.0	0.5	0.0	a2	3.0	8.0	H/V	all	15.0	31.8	-4.9		1.00	3.00	44.1	74.0	74.0	30.1	54.0	54.0	-51.1		23.9
R36	3472.6	3472.6	-4 / 22	all	3.0	3.0	0.5	0.0	a2	3.0	8.0	H/V	all	15.0	31.9	-5.4		1.00	3.00	43.6	74.0	74.0	29.6	54.0	54.0	-51.6		24.4
R37	3906.5	3906.5	-4 / 22	all	3.0	3.0	0.6	0.0	a2	3.0	8.0	H/V	all	15.0	32.0	-5.9		1.00	3.00	45.4	74.0	74.0	31.4	54.0	54.0	-49.8		22.6
R38	4340.4	4340.4	-4 / 22	all	3.0	3.0	0.7	0.0	a2	4.0	8.0	H/V	all	15.0	32.3	-6.3		1.00	3.00	41.7	74.0	74.0	27.7	54.0	54.0	-53.5		26.3
R39	SETUP		OATSC					PCB ONLY			EMCOLOG				CAB001		RSFSV30001		NOTES: H-POL - FLAT, V-POL END Worst Case Orient									

(ROW) (COLUMN) NOTE:
 R0 C5 MR is Measurement Range, which is reduced from DR to achieve necessary SNR.
 R0 C6 DR is the regulatory Desired Range measurement distance.
 R0 C7 N/F is Near-Field / Far-Field distance computed for max of EUT Antenna Dimension (C10) computed above 1 GHz.
 R0 C8 CF is computed using a 20 dB/decade Decay Rate.
 R0 C18/19 When E-field or EIRP is reported directly from Spectrum Analyzer, Antenna Factors and Cable losses are included directly in SA settings and Pr is not reported.

Table 7(e): Transmit Chain Spurious Emissions.

EUT Modes: a4 a8
 a5 434 BAND - 6.9 DB DUTY - MID POWER (0x57) a9
 Test Date(s): 2/1, 2/4, 3/12, 3/20/2019 a6 a10
 Test Engineer: J. Brunett a7 a11

R0	Frequency		Temp. (C) Hum. %	Table Angle deg	Site			EUT			Test Antenna				Cable Kg	Receiver			Field Strength @ DR					EIRP		Details		
	Start MHz	Stop MHz			MR	DR	N/F	CF	Mode see table	Volt. (V)	Dim cm	Pol. H/V	Ant. Height m	Dim. cm		Ka dB/m	Rx Power Pk dBm	Avg	Bandwidth RBW VBW MHz	Meas.	Limit USA	Limit CAN	Qpk / Avg Limit USA	Qpk / Avg Limit CAN	Calc.		Limit	
	MHz	MHz			m	m		dB												dBuV/m					dBm			Pass Fail dB
R1	SETUP				OATSC			PCB ONLY			EMCOLOG				CAB001	RSFSV30001			NOTES: H-POL - FLAT, V-POL END Worst Case Orient									
R2	866.4	866.4	-4 / 22	0.0	3.0	3.0		0.0	a5	3.0	8.0	H	1.0	100.0	15.3	-0.2		0.12	0.30	52.3	80.8	80.8	45.4	60.8	60.8	-42.9		15.4
R3	866.4	866.4	-4 / 22	90.0	3.0	3.0		0.0	a5	3.0	8.0	V	1.1	100.0	15.3	-0.2		0.12	0.30	51.0	80.8	80.8	44.1	60.8	60.8	-44.2		16.7
R4	SETUP				OATSC			PCB ONLY			HRNSINGQR				CAB015	RSFSV30001			NOTES: max all orientations of EUT									
R5	1299.6	1299.6	-4 / 22	all	3.0	3.0	0.2	0.0	a5	3.0	8.0	H/V	all	15.0	22.0	-2.9		1.00	3.00	55.0	74.0	74.0	48.1	54.0	54.0	-40.2		5.9
R6	1732.8	1732.8	-4 / 22	all	3.0	3.0	0.3	0.0	a5	3.0	8.0	H/V	all	15.0	26.6	-3.4		1.00	3.00	41.0	74.0	74.0	34.1	54.0	54.0	-54.2		19.9
R7	2166.0	2166.0	-4 / 22	all	3.0	3.0	0.3	0.0	a5	3.0	8.0	H/V	all	15.0	29.5	-3.9		1.00	3.00	39.9	74.0	74.0	33.0	54.0	54.0	-55.3		21.0
R8	2599.2	2599.2	-4 / 22	all	3.0	3.0	0.4	0.0	a5	3.0	8.0	H/V	all	15.0	31.1	-4.4		1.00	3.00	38.9	74.0	74.0	32.0	54.0	54.0	-56.3		22.0
R9	3032.4	3032.4	-4 / 22	all	3.0	3.0	0.5	0.0	a5	3.0	8.0	H/V	all	15.0	31.8	-4.9		1.00	3.00	37.8	74.0	74.0	30.9	54.0	54.0	-57.4		23.1
R10	3465.6	3465.6	-4 / 22	all	3.0	3.0	0.5	0.0	a5	3.0	8.0	H/V	all	15.0	31.9	-5.4		1.00	3.00	39.1	74.0	74.0	32.2	54.0	54.0	-56.1		21.8
R11	3898.8	3898.8	-4 / 22	all	3.0	3.0	0.6	0.0	a5	3.0	8.0	H/V	all	15.0	32.0	-5.9		1.00	3.00	40.1	74.0	74.0	33.2	54.0	54.0	-55.1		20.8
R12	4332.0	4332.0	-4 / 22	all	3.0	3.0	0.6	0.0	a5	4.0	8.0	H/V	all	15.0	32.3	-6.3		1.00	3.00	41.9	74.0	74.0	35.0	54.0	54.0	-53.3		19.0
R13	SETUP				OATSC			PCB ONLY			EMCOLOG				CAB001	RSFSV30001			NOTES: H-POL - FLAT, V-POL END Worst Case Orient									
R15	867.8	867.8	-4 / 22	0.0	3.0	3.0		0.0	a5	3.0	8.0	H	1.0	100.0	22.2	-0.2		0.12	0.30	50.1	80.8	80.8	43.2	60.8	60.8	-49.2		17.6
R16	867.8	867.8	-4 / 22	90.0	3.0	3.0		0.0	a5	3.0	8.0	V	1.1	100.0	22.2	-0.2		0.12	0.30	49.0	80.8	80.8	42.1	60.8	60.8	-50.3		18.7
R17	SETUP				OATSC			PCB ONLY			EMCOLOG				CAB015	RSFSV30001			NOTES: max all orientations of EUT									
R18	1301.7	1301.7	-4 / 22	all	3.0	3.0	0.2	0.0	a5	3.0	8.0	H/V	all	15.0	22.0	-2.9		1.00	3.00	54.2	74.0	74.0	47.3	54.0	54.0	-41.0		6.7
R19	1735.6	1735.6	-4 / 22	all	3.0	3.0	0.3	0.0	a5	3.0	8.0	H/V	all	15.0	26.7	-3.4		1.00	3.00	40.5	74.0	74.0	33.6	54.0	54.0	-54.7		20.4
R20	2169.5	2169.5	-4 / 22	all	3.0	3.0	0.3	0.0	a5	3.0	8.0	H/V	all	15.0	29.6	-3.9		1.00	3.00	40.1	74.0	74.0	33.2	54.0	54.0	-55.1		20.8
R21	2603.4	2603.4	-4 / 22	all	3.0	3.0	0.4	0.0	a5	3.0	8.0	H/V	all	15.0	31.1	-4.4		1.00	3.00	39.2	74.0	74.0	32.3	54.0	54.0	-56.0		21.7
R22	3037.3	3037.3	-4 / 22	all	3.0	3.0	0.5	0.0	a5	3.0	8.0	H/V	all	15.0	31.8	-4.9		1.00	3.00	39.1	74.0	74.0	32.2	54.0	54.0	-56.1		21.8
R23	3471.2	3471.2	-4 / 22	all	3.0	3.0	0.5	0.0	a5	3.0	8.0	H/V	all	15.0	31.9	-5.4		1.00	3.00	40.2	74.0	74.0	33.3	54.0	54.0	-55.0		20.7
R24	3905.1	3905.1	-4 / 22	all	3.0	3.0	0.6	0.0	a5	3.0	8.0	H/V	all	15.0	32.0	-5.9		1.00	3.00	42.8	74.0	74.0	35.9	54.0	54.0	-52.4		18.1
R25	4339.0	4339.0	-4 / 22	all	3.0	3.0	0.7	0.0	a5	4.0	8.0	H/V	all	15.0	32.3	-6.3		1.00	3.00	40.6	74.0	74.0	33.7	54.0	54.0	-54.6		20.3
R26	SETUP				OATSC			PCB ONLY			EMCOLOG				CAB001	RSFSV30001			NOTES: H-POL - FLAT, V-POL END Worst Case Orient									
R28	869.2	869.2	-4 / 22	0.0	3.0	3.0		0.0	a5	3.0	8.0	H	1.0	100.0	22.2	-0.2		0.12	0.30	51.0	80.9	80.9	44.1	60.9	60.9	-48.3		16.8
R29	869.2	869.2	-4 / 22	90.0	3.0	3.0		0.0	a5	3.0	8.0	V	1.1	100.0	22.2	-0.2		0.12	0.30	48.3	80.9	80.9	41.4	60.9	60.9	-51.0		19.5
R30	SETUP				OATSC			PCB ONLY			EMCOLOG				CAB015	RSFSV30001			NOTES: max all orientations of EUT									
R31	1303.1	1303.1	-4 / 22	all	3.0	3.0	0.2	0.0	a5	3.0	8.0	H/V	all	15.0	22.1	-2.9		1.00	3.00	53.9	74.0	74.0	47.0	54.0	54.0	-41.3		7.0
R32	1737.0	1737.0	-4 / 22	all	3.0	3.0	0.3	0.0	a5	3.0	8.0	H/V	all	15.0	26.7	-3.4		1.00	3.00	41.5	74.0	74.0	34.6	54.0	54.0	-53.7		19.4
R33	2170.9	2170.9	-4 / 22	all	3.0	3.0	0.3	0.0	a5	3.0	8.0	H/V	all	15.0	29.6	-3.9		1.00	3.00	41.0	74.0	74.0	34.1	54.0	54.0	-54.2		19.9
R34	2604.8	2604.8	-4 / 22	all	3.0	3.0	0.4	0.0	a5	3.0	8.0	H/V	all	15.0	31.1	-4.4		1.00	3.00	39.9	74.0	74.0	33.0	54.0	54.0	-55.3		21.0
R35	3038.7	3038.7	-4 / 22	all	3.0	3.0	0.5	0.0	a5	3.0	8.0	H/V	all	15.0	31.8	-4.9		1.00	3.00	39.8	74.0	74.0	32.9	54.0	54.0	-55.4		21.1
R36	3472.6	3472.6	-4 / 22	all	3.0	3.0	0.5	0.0	a5	3.0	8.0	H/V	all	15.0	31.9	-5.4		1.00	3.00	40.0	74.0	74.0	33.1	54.0	54.0	-55.2		20.9
R37	3906.5	3906.5	-4 / 22	all	3.0	3.0	0.6	0.0	a5	3.0	8.0	H/V	all	15.0	32.0	-5.9		1.00	3.00	41.9	74.0	74.0	35.0	54.0	54.0	-53.3		19.0
R38	4340.4	4340.4	-4 / 22	all	3.0	3.0	0.7	0.0	a5	4.0	8.0	H/V	all	15.0	32.3	-6.3		1.00	3.00	41.2	74.0	74.0	34.3	54.0	54.0	-54.0		19.7
R39	SETUP				OATSC			PCB ONLY			EMCOLOG				CAB001	RSFSV30001			NOTES: H-POL - FLAT, V-POL END Worst Case Orient									

(ROW) (COLUMN) NOTE:
 R0 C5 MR is Measurement Range, which is reduced from DR to achieve necessary SNR.
 R0 C6 DR is the regulatory Desired Range measurement distance.
 R0 C7 N/F is Near-Field / Far-Field distance computed for max of EUT Antenna Dimension (C10) computed above 1 GHz.
 R0 C8 CF is computed using a 20 dB/decade Decay Rate.
 R0 C18/19 When E-field or EIRP is reported directly from Spectrum Analyzer, Antenna Factors and Cable losses are included directly in SA settings and Pr is not reported.

Table 7(f): Transmit Chain Spurious Emissions.

EUT Modes: a7 a11
 a8 434 BAND - 0 DB DUTY - MIN POWER (0x3B) a12
 Test Date(s): 2/1, 2/4, 3/12, 3/20/2019 a9
 Test Engineer: J. Brunett a10 a13 a14

R0	Frequency		Site				EUT			Test Antenna				Cable		Receiver		Field Strength @ DR				EIRP		Details			
	Start	Stop	Temp. (C)	Table Angle	MR	DR	N/F	CF	Mode	Volt.	Dim	Pol.	Ant. Height	Dim.	Ka	Kg	Rx Power Pk	Bandwidth Avg	Meas.	Limit	Calc.	Qpk / Avg	Limit		Calc.	Fail	
	MHz	MHz	Hum.	deg	m	m		dB	see table	(V)	cm	H/V	m	cm	dB/m	dB	dBm	MHz	dBuV/m	USA	CAN	USA	CAN		dBm	dB	
R1	SETUP		OATSC				PCB ONLY			EMCOLOG				CAB001	RSFSV30001		NOTES: H-POL - FLAT, V-POL END Worst Case Orient										
R2	866.4	866.4	-4/22	0.0	3.0	3.0		0.0	a8	3.0	8.0	H	1.0	100.0	15.3	-0.2		0.12	0.30	45.3	80.8	80.8	45.3	60.8	60.8	-49.9	15.5
R3	866.4	866.4	-4/22	90.0	3.0	3.0		0.0	a8	3.0	8.0	V	1.1	100.0	15.3	-0.2		0.12	0.30	40.9	80.8	80.8	40.9	60.8	60.8	-54.3	19.9
R4	SETUP		OATSC				PCB ONLY			HRNSINGQR				CAB015	RSFSV30001		NOTES: max all orientations of EUT										
R5	1299.6	1299.6	-4/22	all	3.0	3.0	0.2	0.0	a8	3.0	8.0	H/V	all	15.0	22.0	-2.9		1.00	3.00	45.6	74.0	74.0	45.6	54.0	54.0	-49.6	8.4
R6	1732.8	1732.8	-4/22	all	3.0	3.0	0.3	0.0	a8	3.0	8.0	H/V	all	15.0	26.6	-3.4		1.00	3.00	37.3	74.0	74.0	37.3	54.0	54.0	-57.9	16.7
R7	2166.0	2166.0	-4/22	all	3.0	3.0	0.3	0.0	a8	3.0	8.0	H/V	all	15.0	29.5	-3.9		1.00	3.00	37.3	74.0	74.0	37.3	54.0	54.0	-57.9	16.7
R8	2599.2	2599.2	-4/22	all	3.0	3.0	0.4	0.0	a8	3.0	8.0	H/V	all	15.0	31.1	-4.4		1.00	3.00	38.0	74.0	74.0	38.0	54.0	54.0	-57.2	16.0
R9	3032.4	3032.4	-4/22	all	3.0	3.0	0.5	0.0	a8	3.0	8.0	H/V	all	15.0	31.8	-4.9		1.00	3.00	37.5	74.0	74.0	37.5	54.0	54.0	-57.7	16.5
R10	3465.6	3465.6	-4/22	all	3.0	3.0	0.5	0.0	a8	3.0	8.0	H/V	all	15.0	31.9	-5.4		1.00	3.00	38.2	74.0	74.0	38.2	54.0	54.0	-57.0	15.8
R11	3898.8	3898.8	-4/22	all	3.0	3.0	0.6	0.0	a8	3.0	8.0	H/V	all	15.0	32.0	-5.9		1.00	3.00	38.9	74.0	74.0	38.9	54.0	54.0	-56.3	15.1
R12	4332.0	4332.0	-4/22	all	3.0	3.0	0.6	0.0	a8	4.0	8.0	H/V	all	15.0	32.3	-6.3		1.00	3.00	39.5	74.0	74.0	39.5	54.0	54.0	-55.7	14.5
R13	SETUP		OATSC				PCB ONLY			EMCOLOG				CAB001	RSFSV30001		NOTES: H-POL - FLAT, V-POL END Worst Case Orient										
R15	867.8	867.8	-4/22	0.0	3.0	3.0		0.0	a8	3.0	8.0	H	1.0	100.0	22.2	-0.2		0.12	0.30	46.2	80.8	80.8	46.2	60.8	60.8	-53.1	14.6
R16	867.8	867.8	-4/22	90.0	3.0	3.0		0.0	a8	3.0	8.0	V	1.1	100.0	22.2	-0.2		0.12	0.30	41.2	80.8	80.8	41.2	60.8	60.8	-58.1	19.6
R17	SETUP		OATSC				PCB ONLY			EMCOLOG				CAB015	RSFSV30001		NOTES: max all orientations of EUT										
R18	1301.7	1301.7	-4/22	all	3.0	3.0	0.2	0.0	a8	3.0	8.0	H/V	all	15.0	22.0	-2.9		1.00	3.00	46.8	74.0	74.0	46.8	54.0	54.0	-48.4	7.2
R19	1735.6	1735.6	-4/22	all	3.0	3.0	0.3	0.0	a8	3.0	8.0	H/V	all	15.0	26.7	-3.4		1.00	3.00	37.2	74.0	74.0	37.2	54.0	54.0	-58.0	16.8
R20	2169.5	2169.5	-4/22	all	3.0	3.0	0.3	0.0	a8	3.0	8.0	H/V	all	15.0	29.6	-3.9		1.00	3.00	37.3	74.0	74.0	37.3	54.0	54.0	-57.9	16.7
R21	2603.4	2603.4	-4/22	all	3.0	3.0	0.4	0.0	a8	3.0	8.0	H/V	all	15.0	31.1	-4.4		1.00	3.00	38.4	74.0	74.0	38.4	54.0	54.0	-56.8	15.6
R22	3037.3	3037.3	-4/22	all	3.0	3.0	0.5	0.0	a8	3.0	8.0	H/V	all	15.0	31.8	-4.9		1.00	3.00	37.9	74.0	74.0	37.9	54.0	54.0	-57.3	16.1
R23	3471.2	3471.2	-4/22	all	3.0	3.0	0.5	0.0	a8	3.0	8.0	H/V	all	15.0	31.9	-5.4		1.00	3.00	38.9	74.0	74.0	38.9	54.0	54.0	-56.3	15.1
R24	3905.1	3905.1	-4/22	all	3.0	3.0	0.6	0.0	a8	3.0	8.0	H/V	all	15.0	32.0	-5.9		1.00	3.00	39.8	74.0	74.0	39.8	54.0	54.0	-55.4	14.2
R25	4339.0	4339.0	-4/22	all	3.0	3.0	0.7	0.0	a8	4.0	8.0	H/V	all	15.0	32.3	-6.3		1.00	3.00	40.3	74.0	74.0	40.3	54.0	54.0	-54.9	13.7
R26	SETUP		OATSC				PCB ONLY			EMCOLOG				CAB001	RSFSV30001		NOTES: H-POL - FLAT, V-POL END Worst Case Orient										
R28	869.2	869.2	-4/22	0.0	3.0	3.0		0.0	a8	3.0	8.0	H	1.0	100.0	22.2	-0.2		0.12	0.30	48.9	80.9	80.9	48.9	60.9	60.9	-50.4	12.0
R29	869.2	869.2	-4/22	90.0	3.0	3.0		0.0	a8	3.0	8.0	V	1.1	100.0	22.2	-0.2		0.12	0.30	43.2	80.9	80.9	43.2	60.9	60.9	-56.1	17.7
R30	SETUP		OATSC				PCB ONLY			EMCOLOG				CAB015	RSFSV30001		NOTES: max all orientations of EUT										
R31	1303.1	1303.1	-4/22	all	3.0	3.0	0.2	0.0	a8	3.0	8.0	H/V	all	15.0	22.1	-2.9		1.00	3.00	45.9	74.0	74.0	45.9	54.0	54.0	-49.3	8.1
R32	1737.0	1737.0	-4/22	all	3.0	3.0	0.3	0.0	a8	3.0	8.0	H/V	all	15.0	26.7	-3.4		1.00	3.00	38.0	74.0	74.0	38.0	54.0	54.0	-57.2	16.0
R33	2170.9	2170.9	-4/22	all	3.0	3.0	0.3	0.0	a8	3.0	8.0	H/V	all	15.0	29.6	-3.9		1.00	3.00	38.0	74.0	74.0	38.0	54.0	54.0	-57.2	16.0
R34	2604.8	2604.8	-4/22	all	3.0	3.0	0.4	0.0	a8	3.0	8.0	H/V	all	15.0	31.1	-4.4		1.00	3.00	36.9	74.0	74.0	36.9	54.0	54.0	-58.3	17.1
R35	3038.7	3038.7	-4/22	all	3.0	3.0	0.5	0.0	a8	3.0	8.0	H/V	all	15.0	31.8	-4.9		1.00	3.00	37.1	74.0	74.0	37.1	54.0	54.0	-58.1	16.9
R36	3472.6	3472.6	-4/22	all	3.0	3.0	0.5	0.0	a8	3.0	8.0	H/V	all	15.0	31.9	-5.4		1.00	3.00	38.0	74.0	74.0	38.0	54.0	54.0	-57.2	16.0
R37	3906.5	3906.5	-4/22	all	3.0	3.0	0.6	0.0	a8	3.0	8.0	H/V	all	15.0	32.0	-5.9		1.00	3.00	39.7	74.0	74.0	39.7	54.0	54.0	-55.5	14.3
R38	4340.4	4340.4	-4/22	all	3.0	3.0	0.7	0.0	a8	4.0	8.0	H/V	all	15.0	32.3	-6.3		1.00	3.00	39.8	74.0	74.0	39.8	54.0	54.0	-55.4	14.2
R39	SETUP		OATSC				PCB ONLY			EMCOLOG				CAB001	RSFSV30001		NOTES: H-POL - FLAT, V-POL END Worst Case Orient										

(ROW) (COLUMN) NOTE:
 R0 C5 MR is Measurement Range, which is reduced from DR to achieve necessary SNR.
 R0 C6 DR is the regulatory Desired Range measurement distance.
 R0 C7 N/F is Near-Field / Far-Field distance computed for max of EUT Antenna Dimension (C10) computed above 1 GHz.
 R0 C8 CF is computed using a 20 dB/decade Decay Rate.
 R0 C18/19 When E-field or EIRP is reported directly from Spectrum Analyzer, Antenna Factors and Cable losses are included directly in SA settings and Pr is not reported.

Table 7(g): Transmit Chain Spurious Emissions.

EUT Modes: a3 868 BAND - 7.9 DB DUTY - MAX POWER (0x73)
 a6 868 BAND - 4 DB DUTY - MID POWER (0x63)
 a9 868 BAND - 0 DB DUTY - MIN POWER (0x53)
 Test Date(s): 2/1, 2/4, 3/12, 3/20/2019
 Test Engineer: J. Brunett

R0	Frequency		Temp. (C) Hum. %	Table Angle deg	Site			EUT			Test Antenna			Cable Kg dB/m	Receiver				Field Strength @ DR				EIRP		Details Pass Fail dB				
	Start MHz	Stop MHz			MR	DR	N/F	CF	Mode see table	Volt. (V)	Dim cm	Pol. H/V	Ant. m		Dim. cm	Ka dB/m	Rx Power Pk dBm	Avg	Bandwidth RBW MHz	VBW	Meas.	Limit USA	Calc. CAN	Limit USA		Calc. CAN	Calc.	dBm	
					m	m	dB															dBuV/m							
R1	SETUP				OATSC			PCB ONLY			EMCOLOG			CAB015	RSPSV30001				NOTES: max all orientations of EUT										
R2	1736.6	1736.6	8 / 51	all	3.0	3.0	0.3	0.0	a3	3.0	8.0	H/V	all	15.0	26.7	-3.4		1.00	3.00	57.9	81.9	81.9	50.0	61.9	61.9	-37.3		11.9	
R3	2604.9	2604.9	8 / 51	all	3.0	3.0	0.4	0.0	a3	3.0	8.0	H/V	all	15.0	31.1	-4.4		1.00	3.00	50.1	81.9	81.9	42.2	61.9	61.9	-45.1		19.7	
R4	3473.2	3473.2	8 / 51	all	3.0	3.0	0.5	0.0	a3	3.0	8.0	H/V	all	15.0	31.9	-5.4		1.00	3.00	51.1	81.9	81.9	43.2	61.9	61.9	-44.1		18.7	
R5	4341.5	4341.5	8 / 51	all	3.0	3.0	0.7	0.0	a3	3.0	8.0	H/V	all	15.0	32.3	-6.3		1.00	3.00	50.6	74.0	74.0	42.7	54.0	54.0	-44.6		11.3	
R6	5209.8	5209.8	8 / 51	all	3.0	3.0	0.8	0.0	a3	3.0	8.0	H/V	all	15.0	32.5	-7.2		1.00	3.00	49.1	81.9	81.9	41.2	61.9	61.9	-46.1		20.7	
R7	6078.1	6078.1	8 / 51	all	3.0	3.0	0.9	0.0	a3	3.0	8.0	H/V	all	15.0	32.6	-8.0		1.00	3.00	51.4	81.9	81.9	43.5	61.9	61.9	-43.8		18.4	
R8	6946.4	6946.4	8 / 51	all	3.0	3.0	1.0	0.0	a3	3.0	8.0	H/V	all	15.0	33.0	-8.8		1.00	3.00	55.2	81.9	81.9	47.3	61.9	61.9	-40.0		14.6	
R9	7814.7	7814.7	8 / 51	all	3.0	3.0	1.2	0.0	a3	3.0	8.0	H/V	all	15.0	33.8	-9.5		1.00	3.00	45.8	81.9	81.9	37.9	61.9	61.9	-49.4		24.0	
R10	8683.0	8683.0	8 / 51	all	3.0	3.0	1.3	0.0	a3	4.0	8.0	H/V	all	15.0	34.5	-10.2		1.00	3.00	44.8	81.9	81.9	36.9	61.9	61.9	-50.4		25.0	
R1	SETUP				OATSC			PCB ONLY			EMCOLOG			CAB015	RSPSV30001				NOTES: max all orientations of EUT										
R2	1736.6	1736.6	8 / 51	all	3.0	3.0	0.3	0.0	a6	3.0	8.0	H/V	all	15.0	26.7	-3.4		1.00	3.00	53.7	81.9	81.9	49.7	61.9	61.9	-41.5		12.2	
R3	2604.9	2604.9	8 / 51	all	3.0	3.0	0.4	0.0	a6	3.0	8.0	H/V	all	15.0	31.1	-4.4		1.00	3.00	46.8	81.9	81.9	42.8	61.9	61.9	-48.4		19.1	
R4	3473.2	3473.2	8 / 51	all	3.0	3.0	0.5	0.0	a6	3.0	8.0	H/V	all	15.0	31.9	-5.4		1.00	3.00	39.6	81.9	81.9	35.6	61.9	61.9	-55.6		26.3	
R5	4341.5	4341.5	8 / 51	all	3.0	3.0	0.7	0.0	a6	3.0	8.0	H/V	all	15.0	32.3	-6.3		1.00	3.00	41.0	74.0	74.0	37.0	54.0	54.0	-54.2		17.0	
R6	5209.8	5209.8	8 / 51	all	3.0	3.0	0.8	0.0	a6	3.0	8.0	H/V	all	15.0	32.5	-7.2		1.00	3.00	41.2	81.9	81.9	37.2	61.9	61.9	-54.0		24.7	
R7	6078.1	6078.1	8 / 51	all	3.0	3.0	0.9	0.0	a6	3.0	8.0	H/V	all	15.0	32.6	-8.0		1.00	3.00	43.8	81.9	81.9	39.8	61.9	61.9	-51.4		22.1	
R8	6946.4	6946.4	8 / 51	all	3.0	3.0	1.0	0.0	a6	3.0	8.0	H/V	all	15.0	33.0	-8.8		1.00	3.00	45.9	81.9	81.9	41.9	61.9	61.9	-49.3		20.0	
R9	7814.7	7814.7	8 / 51	all	3.0	3.0	1.2	0.0	a6	3.0	8.0	H/V	all	15.0	33.8	-9.5		1.00	3.00	37.7	81.9	81.9	33.7	61.9	61.9	-57.5		28.2	
R10	8683.0	8683.0	8 / 51	all	3.0	3.0	1.3	0.0	a6	4.0	8.0	H/V	all	15.0	34.5	-10.2		1.00	3.00	39.0	81.9	81.9	35.0	61.9	61.9	-56.2		26.9	
R1	SETUP				OATSC			PCB ONLY			EMCOLOG			CAB015	RSPSV30001				NOTES: max all orientations of EUT										
R2	1736.6	1736.6	8 / 51	all	3.0	3.0	0.3	0.0	a9	3.0	8.0	H/V	all	15.0	26.7	-3.4		1.00	3.00	48.7	81.9	81.9	48.7	61.9	61.9	-46.5		13.2	
R3	2604.9	2604.9	8 / 51	all	3.0	3.0	0.4	0.0	a9	3.0	8.0	H/V	all	15.0	31.1	-4.4		1.00	3.00	43.7	81.9	81.9	43.7	61.9	61.9	-51.5		18.2	
R4	3473.2	3473.2	8 / 51	all	3.0	3.0	0.5	0.0	a9	3.0	8.0	H/V	all	15.0	31.9	-5.4		1.00	3.00	39.7	81.9	81.9	39.7	61.9	61.9	-55.6		22.3	
R5	4341.5	4341.5	8 / 51	all	3.0	3.0	0.7	0.0	a9	3.0	8.0	H/V	all	15.0	32.3	-6.3		1.00	3.00	39.7	74.0	74.0	39.7	54.0	54.0	-55.6		14.4	
R6	5209.8	5209.8	8 / 51	all	3.0	3.0	0.8	0.0	a9	3.0	8.0	H/V	all	15.0	32.5	-7.2		1.00	3.00	40.3	81.9	81.9	40.3	61.9	61.9	-54.9		21.6	
R7	6078.1	6078.1	8 / 51	all	3.0	3.0	0.9	0.0	a9	3.0	8.0	H/V	all	15.0	32.6	-8.0		1.00	3.00	43.2	81.9	81.9	43.2	61.9	61.9	-52.0		18.7	
R8	6946.4	6946.4	8 / 51	all	3.0	3.0	1.0	0.0	a9	3.0	8.0	H/V	all	15.0	33.0	-8.8		1.00	3.00	45.4	81.9	81.9	45.4	61.9	61.9	-49.8		16.5	
R9	7814.7	7814.7	8 / 51	all	3.0	3.0	1.2	0.0	a9	3.0	8.0	H/V	all	15.0	33.8	-9.5		1.00	3.00	37.7	81.9	81.9	37.7	61.9	61.9	-57.5		24.2	
R10	8683.0	8683.0	8 / 51	all	3.0	3.0	1.3	0.0	a9	4.0	8.0	H/V	all	15.0	34.5	-10.2		1.00	3.00	36.6	81.9	81.9	36.6	61.9	61.9	-58.6		25.3	
R11																													
#	C1	C2	C3	C4	C5	C6	C7	C8	C9	C10	C11	C12	C13	C14	C15	C16	C17	C18	C19	C20	C21	C22	C23	C24	C25	C26	C27	C28	C29

(ROW) (COLUMN) NOTE:
 R0 C5 MR is Measurement Range, which is reduced from DR to achieve necessary SNR.
 R0 C6 DR is the regulatory Desired Range measurement distance.
 R0 C7 N/F is Near-Field / Far-Field distance computed for max of EUT Antenna Dimension (C10) computed above 1 GHz.
 R0 C8 CF is computed using a 20 dB/decade Decay Rate.
 R0 C18/19 When E-field or EIRP is reported directly from Spectrum Analyzer, Antenna Factors and Cable losses are included directly in SA settings and Pr is not reported.

Table 7(h): Transmit Chain Spurious Emissions.

EUT Modes: a10 915 BAND - 0 DB DUTY - MAX POWER (0x73)

Test Date(s): 2/1-4/2019
 Test Engineer: J. Brunett

NOTE: Only max power level harmonics are reported as they meet spurious limits for the EUT without duty cycle correction. Compliance as lower power setting assured.

R0	Frequency		Temp. (C) Hum. %	Table Angle deg	Site				EUT			Test Antenna			Cable Kg	Receiver				Field Strength @ DR				EIRP		Details Pass Fail dB		
	Start MHz	Stop MHz			MR	DR	N/F	CF	Mode	Volt.	Dim	Pol.	Ant. Height	Dim.		Ka	Rx Power Pk	Avg	Bandwidth RBW	VBW	Pk		Qpk / Avg		Calc.		Limit	
					m	m		dB	see table	(V)	cm	H/V	m	cm		dB/m	dB	dBm	MHz			USA	CAN	USA	CAN		dBm	dBm
R1	SETUP				OATSC				PCB ALONE			HRNSINGQR			CAB015	RSFSV30001				NOTES: max all orientations of EUT								
R2	1804.8	1804.8	8 / 51	all	3.0	3.0	0.3	0.0	a10	3.0	4.0	H/V	all	15.0	27.2	-3.5		1.00	3.00	52.0	74.0	74.0	52.0	54.0	54.0	-43.2		2.0
R3	2707.1	2707.1	8 / 51	all	3.0	3.0	0.4	0.0	a10	3.0	8.0	H/V	all	15.0	31.3	-4.6		1.00	3.00	43.0	74.0	74.0	43.0	54.0	54.0	-52.2		11.0
R4	3609.5	3609.5	8 / 51	all	3.0	3.0	0.5	0.0	a10	3.0	8.0	H/V	all	15.0	31.9	-5.6		1.00	3.00	36.8	74.0	74.0	36.8	54.0	54.0	-58.4		17.2
R5	4511.9	4511.9	8 / 51	all	3.0	3.0	0.7	0.0	a10	3.0	8.0	H/V	all	15.0	32.0	-6.5		1.00	3.00	38.4	74.0	74.0	38.4	54.0	54.0	-56.8		15.6
R6	5414.3	5414.3	8 / 51	all	3.0	3.0	0.8	0.0	a10	3.0	8.0	H/V	all	15.0	32.5	-7.4		1.00	3.00	37.6	74.0	74.0	37.6	54.0	54.0	-57.6		16.4
R7	6316.6	6316.6	8 / 51	all	3.0	3.0	0.9	0.0	a10	3.0	8.0	H/V	all	15.0	32.7	-8.2		1.00	3.00	39.3	74.0	74.0	39.3	54.0	54.0	-55.9		14.7
R8	7219.0	7219.0	8 / 51	all	3.0	3.0	1.1	0.0	a10	3.0	8.0	H/V	all	15.0	33.3	-9.0		1.00	3.00	30.2	74.0	74.0	30.2	54.0	54.0	-65.0		23.8
R9	8121.4	8121.4	8 / 51	all	3.0	3.0	1.2	0.0	a10	3.0	8.0	H/V	all	15.0	34.1	-9.8		1.00	3.00	32.8	74.0	74.0	32.8	54.0	54.0	-62.4		21.2
R10	9023.8	9023.8	8 / 51	all	3.0	3.0	1.4	0.0	a10	4.0	8.0	H/V	all	15.0	34.8	-10.4		1.00	3.00	31.1	74.0	74.0	31.1	54.0	54.0	-64.1		22.9
R11																												
R12	SETUP				OATSC				PCB ALONE			HRNSINGQR			CAB015	RSFSV30001				NOTES: max all orientations of EUT								
R13	1830.0	1830.0	8 / 51	all	3.0	3.0	0.3	0.0	a10	3.0	4.0	H/V	all	15.0	27.4	-3.5		1.00	3.00	52.5	74.0	74.0	52.5	54.0	54.0	-42.7		1.5
R14	2745.0	2745.0	8 / 51	all	3.0	3.0	0.4	0.0	a10	3.0	8.0	H/V	all	15.0	31.4	-4.6		1.00	3.00	46.6	74.0	74.0	46.6	54.0	54.0	-48.6		7.4
R15	3660.0	3660.0	8 / 51	all	3.0	3.0	0.5	0.0	a10	3.0	8.0	H/V	all	15.0	31.9	-5.6		1.00	3.00	41.9	74.0	74.0	41.9	54.0	54.0	-53.3		12.1
R16	4575.0	4575.0	8 / 51	all	3.0	3.0	0.7	0.0	a10	3.0	8.0	H/V	all	15.0	32.1	-6.6		1.00	3.00	39.1	74.0	74.0	39.1	54.0	54.0	-56.1		14.9
R17	5490.0	5490.0	8 / 51	all	3.0	3.0	0.8	0.0	a10	3.0	8.0	H/V	all	15.0	32.5	-7.5		1.00	3.00	38.1	74.0	74.0	38.1	54.0	54.0	-57.1		15.9
R18	6405.0	6405.0	8 / 51	all	3.0	3.0	1.0	0.0	a10	3.0	8.0	H/V	all	15.0	32.7	-8.3		1.00	3.00	41.3	74.0	74.0	41.3	54.0	54.0	-53.9		12.7
R19	7320.0	7320.0	8 / 51	all	3.0	3.0	1.1	0.0	a10	3.0	8.0	H/V	all	15.0	33.3	-9.1		1.00	3.00	33.4	74.0	74.0	33.4	54.0	54.0	-61.8		20.6
R20	8235.0	8235.0	8 / 51	all	3.0	3.0	1.2	0.0	a10	3.0	8.0	H/V	all	15.0	34.2	-9.9		1.00	3.00	31.7	74.0	74.0	31.7	54.0	54.0	-63.5		22.3
R21	9150.0	9150.0	8 / 51	all	3.0	3.0	1.4	0.0	a10	4.0	8.0	H/V	all	15.0	34.9	-10.5		1.00	3.00	30.6	74.0	74.0	30.6	54.0	54.0	-64.6		23.4
R22																												
R23	SETUP				OATSC				PCB ALONE			HRNSINGQR			CAB015	RSFSV30001				NOTES: max all orientations of EUT								
R24	1855.4	1855.4	8 / 51	all	3.0	3.0	0.3	0.0	a10	3.0	4.0	H/V	all	15.0	27.6	-3.6		1.00	3.00	51.7	74.0	74.0	51.7	54.0	54.0	-43.5		2.3
R25	2757.7	2757.7	8 / 51	all	3.0	3.0	0.4	0.0	a10	3.0	8.0	H/V	all	15.0	31.4	-4.6		1.00	3.00	44.1	74.0	74.0	44.1	54.0	54.0	-51.1		9.9
R26	3660.1	3660.1	8 / 51	all	3.0	3.0	0.5	0.0	a10	3.0	8.0	H/V	all	15.0	31.9	-5.6		1.00	3.00	39.0	74.0	74.0	39.0	54.0	54.0	-56.2		15.0
R27	4562.5	4562.5	8 / 51	all	3.0	3.0	0.7	0.0	a10	3.0	8.0	H/V	all	15.0	32.1	-6.5		1.00	3.00	39.3	74.0	74.0	39.3	54.0	54.0	-55.9		14.7
R28	5464.9	5464.9	8 / 51	all	3.0	3.0	0.8	0.0	a10	3.0	8.0	H/V	all	15.0	32.5	-7.4		1.00	3.00	37.9	74.0	74.0	37.9	54.0	54.0	-57.3		16.1
R29	6367.2	6367.2	8 / 51	all	3.0	3.0	1.0	0.0	a10	3.0	8.0	H/V	all	15.0	32.7	-8.3		1.00	3.00	39.3	74.0	74.0	39.3	54.0	54.0	-55.9		14.7
R30	7269.6	7269.6	8 / 51	all	3.0	3.0	1.1	0.0	a10	3.0	8.0	H/V	all	15.0	33.3	-9.1		1.00	3.00	32.0	74.0	74.0	32.0	54.0	54.0	-63.2		22.0
R31	8172.0	8172.0	8 / 51	all	3.0	3.0	1.2	0.0	a10	3.0	8.0	H/V	all	15.0	34.1	-9.8		1.00	3.00	30.9	74.0	74.0	30.9	54.0	54.0	-64.3		23.1
R32	9074.4	9074.4	8 / 51	all	3.0	3.0	1.4	0.0	a10	4.0	8.0	H/V	all	15.0	34.8	-10.5		1.00	3.00	32.4	74.0	74.0	32.4	54.0	54.0	-62.8		21.6
R33																												

C1 C2 C3 C4 C5 C6 C7 C8 C9 C10 C11 C12 C13 C14 C15 C16 C17 C18 C19 C20 C21 C22 C23 C24 C25 C26 C27 C28 C29

(ROW) (COLUMN) NOTE:

R0 C5 MR is Measurement Range, which is reduced from DR to achieve necessary SNR.

R0 C6 DR is the regulatory Desired Range measurement distance.

R0 C7 N/F is Near-Field / Far-Field distance computed for max of EUT Antenna Dimension (C10) computed above 1 GHz.

R0 C8 CF is computed using a 20 dB/decade Decay Rate.

R0 C18/19 When E-field or EIRP is reported directly from Spectrum Analyzer, Antenna Factors and Cable losses are included directly in SA settings and Pr is not reported.

4.3.2 Radiated Digital Spurious

The results for the measurement of digital spurious emissions are not reported herein as all digital emissions were greater than 20 dB below the regulatory limit. Radiation from digital components was measured to 4 GHz, or to five times the maximum digital component operating frequency, whichever is greater.

5 Measurement Uncertainty and Accreditation Documents

The maximum values of measurement uncertainty for the laboratory test equipment and facilities associated with each test are given in the table below. This uncertainty is computed for a 95.45% confidence level based on a coverage factor of $k = 2$.

Table 8: Measurement Uncertainty.

Measured Parameter	Measurement Uncertainty [†]
Radio Frequency	$\pm(f_{Mkr}/10^7 + RBW/10 + (SPN/(PTS - 1))/2 + 1 \text{ Hz})$
Conducted Emm. Amplitude	$\pm 1.9 \text{ dB}$
Radiated Emm. Amplitude (30 – 200 MHz)	$\pm 4.0 \text{ dB}$
Radiated Emm. Amplitude (200 – 1000 MHz)	$\pm 5.2 \text{ dB}$
Radiated Emm. Amplitude ($f > 1000 \text{ MHz}$)	$\pm 3.7 \text{ dB}$

[†]Ref: CISPR 16-4-2:2011+A1:2014



FEDERAL COMMUNICATIONS COMMISSION
 Laboratory Division
 7435 Oakland Mills Road
 Columbia, MD 21046
 July 06, 2018

National Voluntary Laboratory Accreditation Program
 100 Bureau Drive
 Gaithersburg, MD 20899-2140

Attention: Timothy Rasinski

Re: Accreditation of AHD (Amber Helm Development, L.C.)
 Designation Number: US5348
 Test Firm Registration #: 639064

Dear Sir or Madam:

We have been notified by National Voluntary Laboratory Accreditation Program that AHD (Amber Helm Development, L.C.) has been accredited as a testing laboratory.

At this time AHD (Amber Helm Development, L.C.) is hereby recognized to perform compliance testing on equipment subject to Declaration of Conformity (DOC) and Certification of the Commission's Rules.

This recognition will expire upon expiration of the accreditation or notification of withdrawal of recognition.

Any questions about this recognition should be submitted as an inquiry to the FCC Knowledge Database at www.fcc.gov/kdb.

Sincerely,

George Tanshill
 Electronics Engineer



Figure 7: Accreditation Documents