

# XT Series Reader Manual

English



**TagMaster**

**Note:** This equipment has FCCID M39XTMX (XT Mini), M39XTXX (XT-1), or **M39XTMEX (XT-5/XT-5 ETC)**. It complies with the limits for a Class A digital device, pursuant to part 15 of the FCC Rules. These limits are designed to provide reasonable protection against harmful interference when the equipment is operated in a commercial environment. This equipment generates, uses, and can radiate radio frequency energy and, if not installed and used in accordance with the instruction manual, may cause harmful interference to radio communications. Operation of this equipment in a residential area is likely to cause harmful interference in which case the user will be required to correct the interference at his own expense.

**Warning:** Operation of the equipment requires professional installation to correctly set the TX power for the RF cable and antenna selected.

The users are prohibited from making any change or modifications to this product. Any modification to this product shall void the user's authority to operate under FCC Part 15 regulations. This device complies with Part 15 of the FCC Rules. Operation is subject to the following two conditions: (1) This device may not cause harmful interference and, (2) this device must accept any interference received, including interference that may cause undesired operation.

**Caution:** Changes or modifications not expressly approved by the party responsible for compliance could void the user's authority to operate the equipment.

**Caution:** To comply with Council Recommendation 1999/519/EC and FCC regulations, this equipment must be installed to provide a separation distance of at least 20 cm (XT Mini), 25 cm (XT-1) and 30 cm (**XT-5 and XT-5 ETC**) from all persons and must not be co-located or operating in conjunction with any other antenna or transmitter.

**Copyright**

The copyright and ownership of this document belongs to TagMaster AB. The document may be downloaded or copied provided that all copies contain the full information from the complete document. All other copying requires a written approval from TagMaster AB.

**Disclaimer**

While effort has been taken to ensure the accuracy of the information in this document TagMaster AB assumes no responsibility for any errors or omissions, or for damages resulting from the use of the information contained herein. The information in this document is subject to change without notice.

**Table of Contents**

<b>1</b>	<b>Introduction</b>	<b>5</b>
1.1	Readers.....	5
1.2	Tags.....	5
1.3	SecureMarkID®.....	5
<b>2</b>	<b>Installation</b>	<b>5</b>
2.1	Safety Instructions.....	5
2.2	Reader and Tag Placement.....	6
2.3	Mounting Instructions.....	8
2.3.1	Universal Mounting Kit (UMK).....	8
2.3.2	Dimensions.....	8
2.4	Cable Connections.....	9
2.4.1	XT Mini.....	9
2.4.2	XT-1.....	9
2.4.3	XT-5 / XT-5 ETC.....	10
2.5	Wire Connections.....	11
2.5.1	Spring Cage Terminals.....	11
2.5.2	Ethernet and USB.....	11
2.6	External Antennas.....	11
<b>3</b>	<b>Interfaces</b>	<b>12</b>
3.1	Overview.....	12
3.2	Power Supply.....	13
3.3	Ethernet.....	13
3.4	Wiegand/Magstripe.....	14
3.4.1	Wiegand Timing.....	16
3.4.2	Magstripe Timing.....	16
3.5	Status Indicators.....	17
3.6	RS232.....	17
3.7	RS485.....	18
3.8	Inputs.....	19
3.9	Light and Sound.....	19
3.10	Relay.....	20
3.11	MicroSD Memory Card Slot.....	20
3.12	USB Device.....	20
3.13	USB Host (XT-5, XT-5 ETC).....	20
3.14	Tamper Switch (XT Mini, XT-5, XT-5 ETC).....	21
3.15	DIP Switches.....	21
3.15.1	Interface Configuration DIP Switch (IF_DIP/S301).....	21
3.15.2	Software Configuration DIP Switch (SW_DIP/S101).....	22
<b>4</b>	<b>Configuration</b>	<b>23</b>
4.1	Web Interface.....	23

4.1.1	Start .....	23
4.1.2	Information .....	23
4.1.3	Settings... ..	24
4.1.4	Access Controller... ..	24
4.1.5	Web Tools... ..	24
4.1.6	Documentation .....	24
4.1.7	Reboot .....	24
4.2	Region .....	25
4.3	Tag Reading .....	25
4.3.1	Carrier and Read Level .....	25
4.3.2	EPC Select.....	25
4.3.3	EPC Memory Bank/Custom Format .....	25
4.3.4	Tag Filter.....	25
4.3.5	Data Selection.....	26
4.3.6	Data Format.....	26
4.4	Firmware Upgrade.....	26
4.5	Factory Defaults.....	26
<b>5</b>	<b>Connecting to an External System</b>	<b>27</b>
5.1	Wiegand/Magstripe .....	27
5.1.1	Easy Configuration.....	27
5.2	OSDP (RS485) .....	30
5.2.1	Easy Configuration.....	30
5.3	Push (RS232, RS485, TCP/IP) .....	32
5.4	TAGP (TCP/IP).....	32
5.5	Other Protocols.....	32
<b>6</b>	<b>Built-in Access Controller</b>	<b>33</b>
<b>7</b>	<b>Troubleshooting</b>	<b>34</b>
<b>8</b>	<b>Definitions and Abbreviations</b>	<b>34</b>
<b>9</b>	<b>References</b>	<b>34</b>
<b>10</b>	<b>Technical Specification</b>	<b>35</b>

# 1 Introduction

## 1.1 Readers

XT Mini, XT-1, XT-5 and XT-5 ETC are RAIN RFID readers that are compliant with EPC Gen 2 and ISO 18000-63. XT Mini and XT-1 has a single integrated antenna. XT-5 has one integrated antenna and support for one external antenna. XT-5 ETC supports up to four external antennas. The readers are tailored for automatic vehicle identification applications such as parking, gated communities, and road tolls. As such, the readers are designed for outdoor use and support a large number of interfaces and protocols.

RAIN RFID readers operate in the 860-960 MHz UHF frequency range. To support varying global regulations, the readers come in two versions: EU that operates in the 865-868 MHz range and US that operates in the 902-928 MHz range. Both versions can be configured to work in multiple regions within the respective frequency band.

While XT Mini and XT-1 have fixed firmware, XT-5 and XT-5 ETC have a user-programmable Linux system. See "XT-5 / XT-5 ETC Developers Manual" [1] for more information.



## 1.2 Tags

RAIN RFID tags are typically passive, which means that they are powered by the reader's electromagnetic field instead of having a battery. TagMaster's XT readers support all RAIN RFID tags. Specifically, the readers support the SecureMarkID® tags developed by TagMaster to ensure that each tag has a truly unique identity that is difficult to clone.

## 1.3 SecureMarkID®

RAIN RFID was originally not developed for access control and therefore has a few weaknesses in these applications. Even if all modern tags have a unique ID, this is often too long for existing access control systems and tags cannot be bought with the IDs in sequence. User-programmed tags can often be cloned by anybody with access to a RAIN RFID reader.

To address this issue, TagMaster has developed the SecureMarkID® format that uses an encryption algorithm and non-writeable parts of the tags to create a unique 9-digit ID that works well with access control systems, can be bought in sequence, and is difficult to clone. It is recommend to only use SecureMarkID® tags with the reader.

# 2 Installation

## 2.1 Safety Instructions

The following safety instructions should be observed during installation, normal use, and service.

- Installation and service should only be done by qualified personnel.
- Shields of cables should be connected to safety ground.
- The reader must be disconnected from all voltage sources before any installation or service work. Capacitors inside the reader can hold their charge even if the equipment has been disconnected from all voltage sources.
- Do not modify any part of the product. Repair is to be performed by TagMaster only.
- Where local regulations exist, these are to be followed. The safety information in this manual is a supplement to local regulations. It is the responsibility of the local project manager to make certain that local regulations are known and followed.

## 2.2 Reader and Tag Placement

Figure 1 shows some typical installations for the XT-1, XT-5 and XT-5 ETC readers:

- A. Single lane parking entrance. The reader is directed to read windshield or headlight tags.
- B. Multilane parking entrance. To minimize the risk for cross reads, the readers/antennas are mounted above the cars and the cars are equipped with windshield or headlight tags.
- C. Access control (at the gate) and vehicle identification (at the weighbridge). The trucks are equipped with ISO card tags that are mounted in a holder on the windshield and read from the side.
- D. Traffic control. Readers are used to enable a green wave for buses.

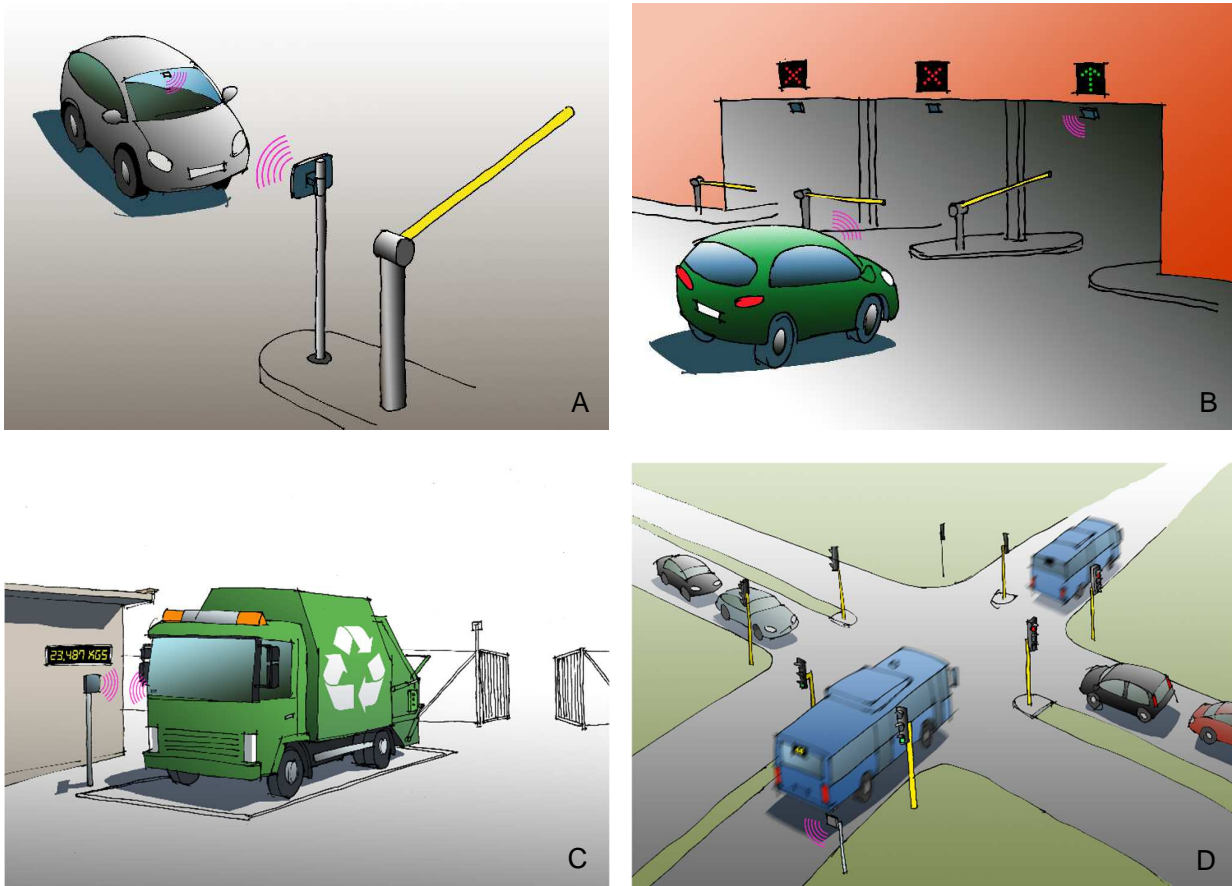

Figure 1 XT-1 installations

Figure 2 shows two installations with side-mounted readers.

- A. XT Mini is optimal for parking access with moderate read range requirements.
- B. A side-mounted XT-1 or XT-5 covers a wide road.

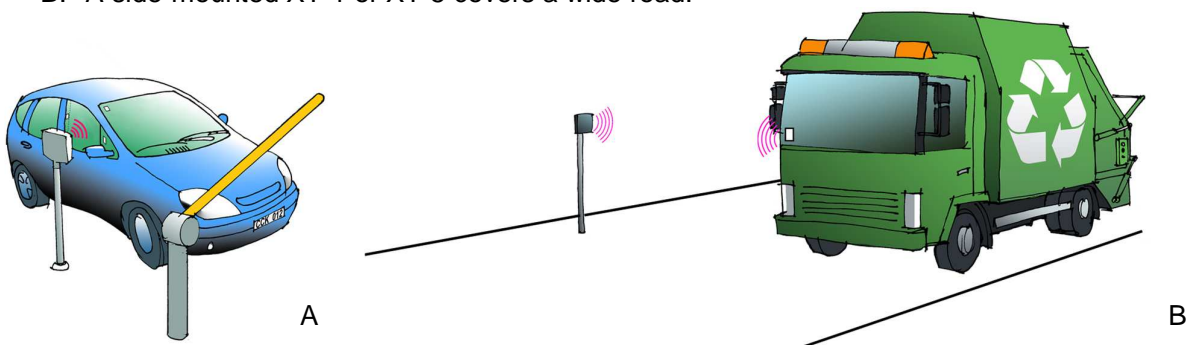

Figure 2 Side-mounted reader (A: XT Mini, B: XT-1/XT-5)

The reader's radiation pattern or read lobe (the region where the reader can read tags) is shaped like a balloon in front of the reader as shown in Figure 3. The maximum read range is obtained when the tag is at the tip of the balloon. At or close to this point, the width of the balloon is very small, which means that the tag has to be accurately positioned to be read. It is recommended to mount the reader such that the tag can be read at the widest part of the balloon which is at around 60-70% of maximum read range. If required, the maximum read range can be reduced as described in section 4.3.1.

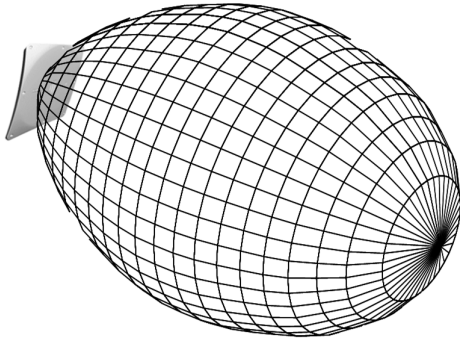

Figure 3 Reader radiation pattern

The reader should be mounted such that there is free sight between the reader and the tag. Radio waves from the reader cannot pass through metal or objects containing water (such as humans). Metallic objects close to the reader may cause reflections that can significantly reduce the read range.

Different tags have different mounting requirements. ISO card tags are generally optimized for free air and - if used in a car - should be mounted in a card holder that creates an air gap between the tag and the windshield. Windshield tags must be mounted on the windshield for optimal performance. Typical tags do not work if they are mounted on metal or objects containing water. Metallized windshields may prevent tag reading as they block radio waves.

Most RAIN RFID tags have a donut shaped radiation pattern as shown in Figure 4. This means that the tags can be read not only when the front side is facing the reader, but also when the backside or long edges are facing the reader. If the tag is turned such that one of the short edges is facing the reader, the read range drops rapidly.

If the reader is mounted beside the car, the tag should be mounted with the donut lying as shown in the left part of Figure 4. Note that the tag can be mounted in the windshield and read when the long edge of the tag is facing the reader. If the windshield is metallized, the tag can be mounted in the side window or on the front of the B-pillar (with a suitable holder creating a distance from the metal). A side-mounted reader together with a tag with a lying donut can be used to cover a wide road as shown in Figure 2 B.

If the reader is mounted above or in front of the car, the tag should be mounted with the donut standing as shown in the right part of Figure 4. In a multilane installation (Figure 1 B) it is recommended to mount the tags like this with the reader above the car to reduce the risk of cross reads. If the windshield is metallized, a transparent tag can be mounted on the headlight.

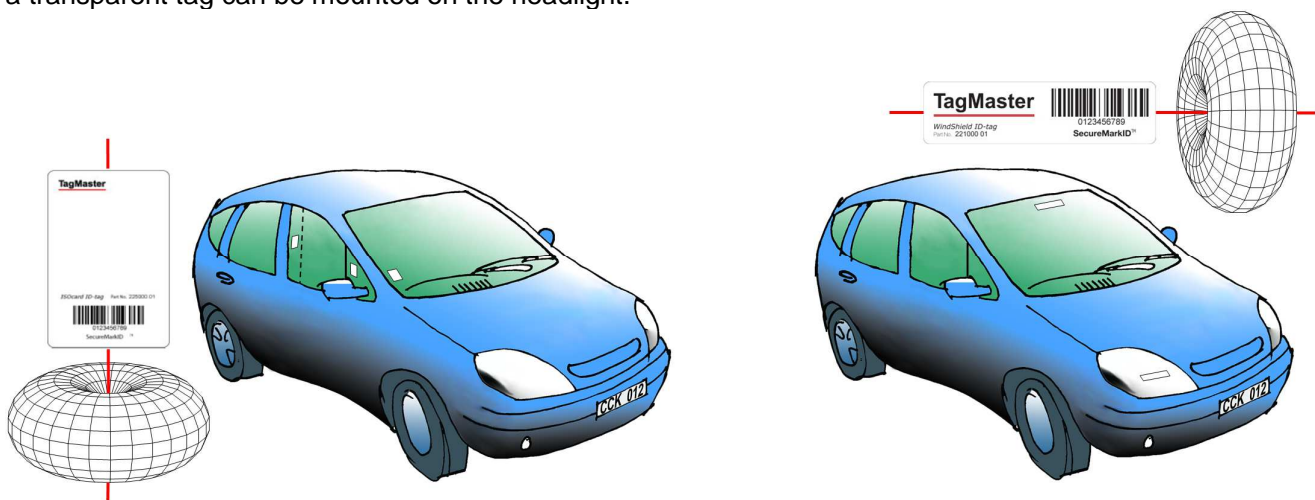

Figure 4 Tag radiation patterns and example placement



## 2.3 Mounting Instructions

Mount the reader in a horizontal position with the cable glands down. Study the installation examples and radiation patterns in section 2.2 to determine the optimal placement of readers and tags in your installation.

### 2.3.1 Universal Mounting Kit (UMK)

The UMK (TagMaster part. no. 193600) makes it easy to mount the reader in a wide variety of positions and angles. The kit contains all parts needed to mount the reader on a wall or a pole. The kit is designed and suitable for outdoor use. See separate datasheet [1] for more details in on installation.



Figure 5 Universal Mounting Kit (UMK)

### 2.3.2 Dimensions

Reader dimensions are shown in Figure 6 (XT-1/XT-5/XT-5 ETC to the left, XT Mini to the right).

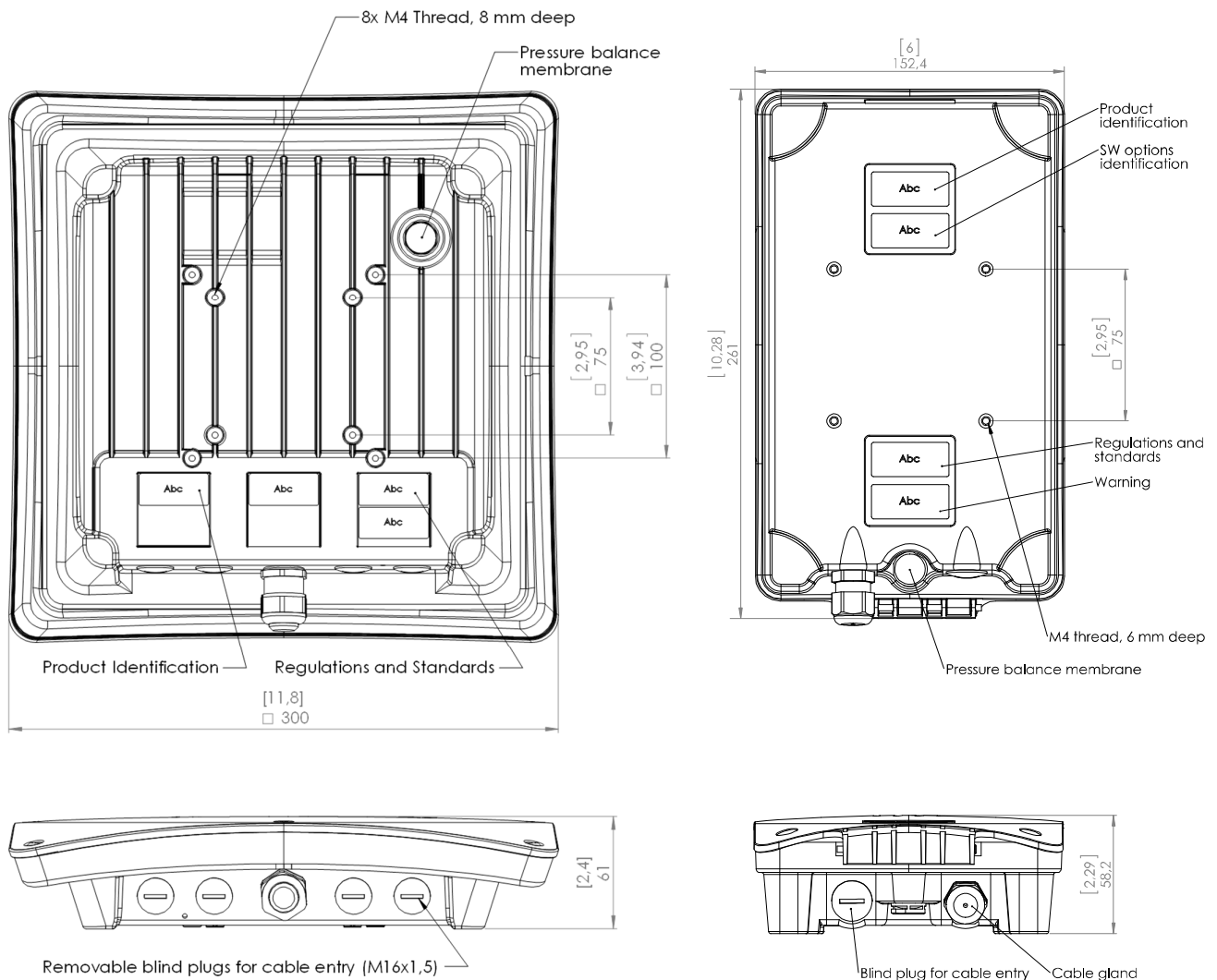

Figure 6 Reader Dimensions in [inch] and mm



## 2.4 Cable Connections

### 2.4.1 XT Mini

In XT Mini, cables should be connected through the two M16 cable glands. A cable tie should be used to guide the wires when the lid is closed. Make sure to use cables with flexible wires. It is recommended to use the left cable gland for Ethernet connections and the right cable gland for other connections. An example with power, Ethernet and RS485 connections is shown in Figure 7.

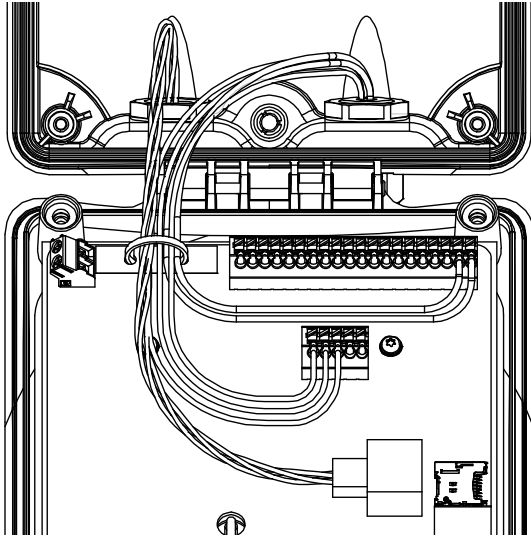

Figure 7 XT Mini with power, Ethernet and RS485 connections

### 2.4.2 XT-1

In XT-1, cables should primarily be connected through the central M20 cable gland. This cable gland can be used with one cable ( $\varnothing$  6-12 mm) or two cables ( $\varnothing$  2-6 mm) using the supplied insert. As an alternative, one or more of the four M16 blind plugs can be replaced with cable glands. Use shielded flexible cables with stranded wire. Ground the reader chassis using the grounding screw.

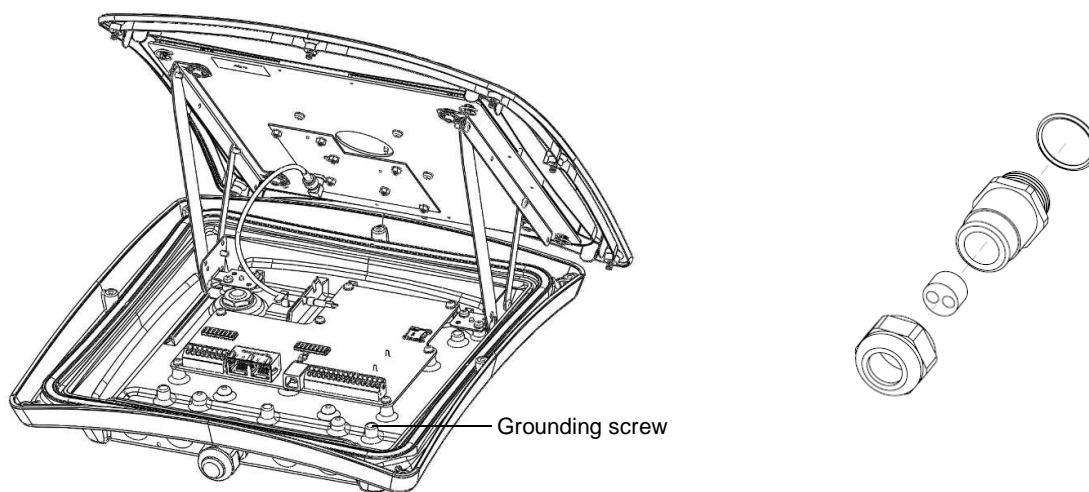

Figure 8 XT-1 with open lid (left), cable gland with insert for two cables (right)

### 2.4.3 XT-5 / XT-5 ETC

With XT-5 and XT-5 ETC, Ethernet and power (PoE+) should normally be connected to the external RJ45 connector. On XT-5, the three M16 blind plugs can be replaced with cable glands if more connections are needed. On XT-5 ETC, the external RJ45 connector can be replaced by a M20 cable gland for one or more cables (the same type of cable gland that is used for XT-1).

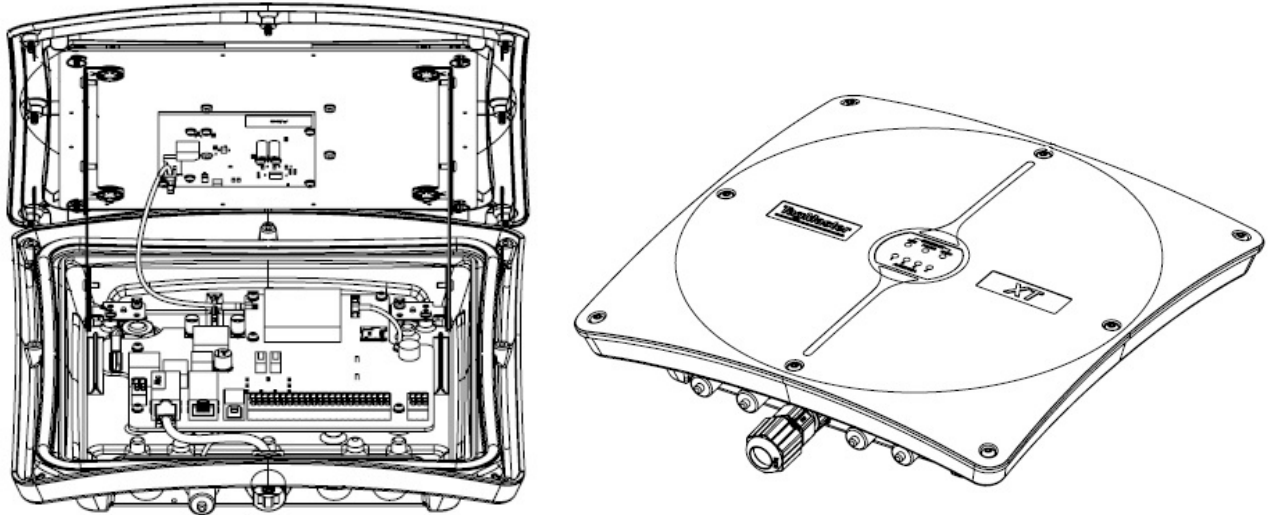

Figure 9 XT-5 with lid open (left) and XT-5 ETC with lid closed (right).

---

---

#### **⚠ Important!**

This device complies with part 15 of the FCC Rules. Operation is subject to the following two conditions: (1) This device may not cause harmful interference, and, (2) This device must accept any interference received including interference that may cause undesired operation.

---

---

## 2.5 Wire Connections

### 2.5.1 Spring Cage Terminals

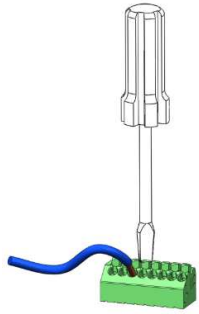

With the exception of Ethernet and USB, all wires are connected to spring cage terminals. These terminals are easy to use and work with both solid and stranded wires.

#### Instructions

1. Strip wire lead approximately 9 mm.
2. Push screwdriver down to release spring cage.
3. Insert wire into terminal.
4. Remove screwdriver to clamp wire.
5. Gently pull installed wire to make sure connection is reliable.

Wire size	0.5 mm <sup>2</sup> - 1.5 mm <sup>2</sup> (AWG 20 - AWG 16)
-----------	---

Table 1 Wire connection overview

### 2.5.2 Ethernet and USB

Ethernet connections are made with standard RJ45 connectors. In XT-5 and XT-5 ETC, the first Ethernet port is available externally. For XT Mini, XT-1 and the second Ethernet port in XT-5 and XT-5 ETC, make sure to pass the Ethernet cable through the cable gland before crimping the connector to the cable.

USB connections are made with standard type A and B connectors.

## 2.6 External Antennas

**ADD INFORMATION FOR XT-5 AND XT-5 ETC!**

### 3 Interfaces

#### 3.1 Overview

Figure 10 shows the locations of all interfaces in the different reader models. The name of each interface is listed in Table 2. The following sections refer to the interfaces as named in the table.

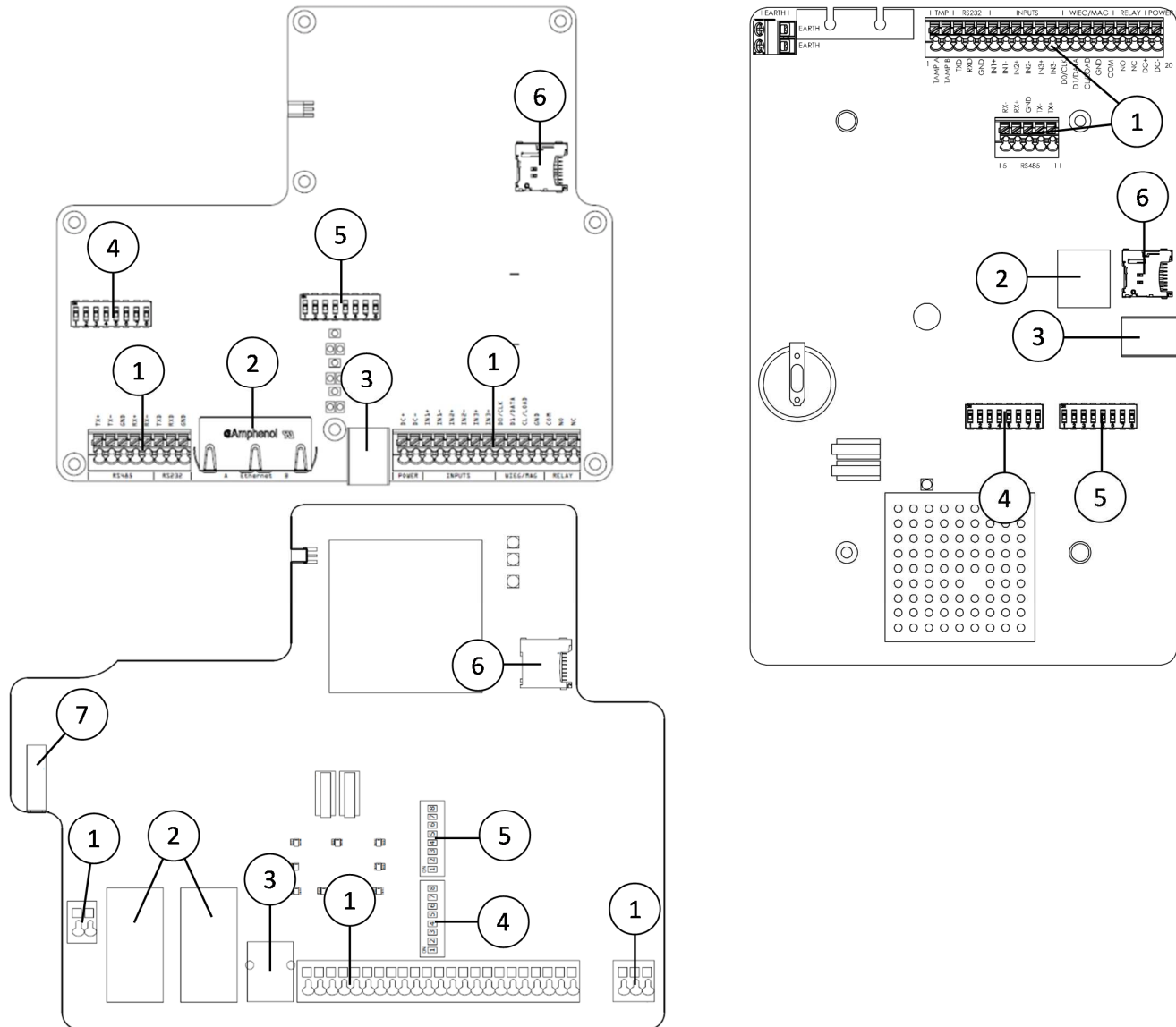

Figure 10 XT-1 (top left), XT-5/XT-5 ETC (bottom left), and XT Mini (right) interface locations

Position	Interface(s)
1	POWER, RS232, RS485, INPUTS, WIEG/MAG, RELAY, TAMPER (all models except XT-1)
2	ETHERNET (with PoE+ on XT-5 and XT-5 ETC)
3	USB DEV
4	DIP S301/IF_DIP
5	DIP S101/SW_DIP
6	MICROSD
7	USB HOST (XT-5 and XT-5 ETC)

Table 2 Interface names

## 3.2 Power Supply

XT Mini and XT-1 have a single 12-24 VDC power supply input. XT-5 and XT-5 ETC can be powered either from 12-24 VDC or Power-over-Ethernet (PoE+, IEEE 802.3at). When using the power supply input, the readers shall be powered from an isolated power supply. It is recommended to use a power supply of 24 VDC, **0.5 A minimum**.

The power supply input has built-in reverse polarity protection.

Connections	XT-1, XT Mini	POWER:DC+	High supply potential
		POWER:DC-	Low supply potential (ground)
	XT-5, XT-5 ETC	POWER:12-24 VDC	High supply potential
		POWER:0 VDC	Low supply potential (ground)
Supply voltage	12 VDC to 24 VDC (Absolute minimum rating 10 VDC, absolute maximum rating 30 VDC)		
Max cable length	100 m		
Wire size	Recommended 1.5 mm <sup>2</sup> (AWG 16)		

**Table 3 Power connection overview**

## 3.3 Ethernet

The reader has a 10 Mbps/100 Mbps Ethernet interface with one or two ports. The interface supports auto crossover (Auto-MDIX) so that installation can be done using either patch cables or crossover cables. In XT-5 and XT-5 ETC one of the ports supports Power over Ethernet (PoE+, IEEE 802.3at).

Connections	XT Mini	ETHERNET:A	Ethernet port
	XT-1	ETHERNET:A	Ethernet port
		ETHERNET:B	Ethernet port
	XT-5	ETH A/PoE+	Ethernet/PoE+ port (external RJ45)
		ETH B	Ethernet port
	XT-5 ETC	ETH_A/PoE+	Ethernet/PoE+ port (external RJ45)
ETH B (internal)		Ethernet port	
Max cable length	100 m		
Wire size	CAT5e cable or better is required for the Ethernet connection		

**Table 4 Ethernet connection overview**

All IP settings can be changed under Settings.../Interfaces.../Ethernet in the web interface. A reboot is required to activate new settings.

For XT Mini and XT-1, the reader's default IP address and subnet mask can be found on a label on the backside of the reader. The default address is on the format 10.x.x.x and the subnet mask is 255.0.0.0.

The XT-5 and XT-5 ETC readers are by default configured to get IP settings from a DHCP server. If no DHCP server is available, these readers will auto-assign an IP address in the range 169.254.x.x/16.

For convenience, it is possible to force the reader to use a fixed IP address by setting SW\_DIP/S101:3 to ON before starting the reader. The IP address will then be 169.254.1.1 and the subnet mask 255.255.0.0. A PC that is directly connected to a reader will usually get an IP address in this subnet automatically.

A reader discovery tool is available at <ftp://partner:245ghz@ftp.tagmaster.com/Vigilant>. This tool can find readers on a local network even if their IP settings are completely incorrect. The readers can then be restored to factory defaults and their IP settings can be configured. XT-5 and XT-5 ETC also support UPnP and Bonjour (mDNS/DNS-SD). These protocols make the readers visible under Network in Windows Explorer and under Bonjour in Apple Safari.

XT-1, XT-5 and XT-5 ETC have a built-in two-port Ethernet switch which enables chaining of readers.

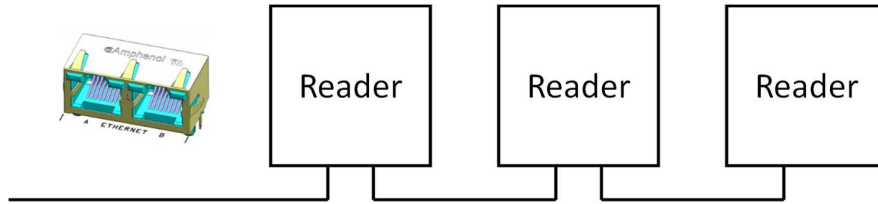

**Figure 11 Readers connected in a chain using the built-in Ethernet switch**

The readers support ICMP echo request/reply (ping) to simplify network troubleshooting. By default, ping beep is enabled which means that the reader beeps when it receives a ping packet. Ping beep can be used to identify which reader that has a specific IP address or to determine if ping packets get lost on the way to the reader or from the reader. Ping beep can be disabled using the web interface.

The reader can work as a TCP server and/or TCP client. As a client, the reader automatically connects to a specified TCP server when it has data to send. The IP address and port of the server and the protocol to use can be configured under Settings.../Interfaces.../Ethernet in the web interface. Supported protocols are Push and TAGP. As a TCP server, the reader supports several protocols, including TAGP.

### 3.4 Wiegand/Magstripe

The readers have one or two Wiegand/Magstripe interfaces. XT Mini and XT-1 have one interface. XT-5 and XT-5 ETC have two interfaces (A and B) that can be configured as a single interface using IF\_DIP:7 if a card load signal is needed. With dual interfaces, tag reads from different antennas are sent to different interfaces. Tag reads from antenna 1 (the internal antenna in XT-5) are sent to interface A.

Connections (Wiegand)	XT Mini, XT-1	WIEG:D0	Wiegand 0
		WIEG:D1	Wiegand 1
		WIEG:CL	Card load
		WIEG:GND	Signal ground #1
	XT-5, XT-5 ETC	WIEG:D0 A	Interface A, Wiegand 0
		WIEG:D1 A	Interface A, Wiegand 1
		WIEG:GND	Signal ground #1
		WIEG:D0 B	Interface B, Wiegand 0 (IF_DIP:7 OFF) Interface A, Card load (IF_DIP:7 ON)
		WIEG:D1 B	Interface B, Wiegand 1
	Connections (Magstripe)	XT Mini, XT-1	MAG:CLK
MAG:DATA			Magstripe data
MAG:LOAD			Card load
MAG:GND			Signal ground #1
XT-5, XT-5 ETC		MAG:CK A	Interface A, Magstripe clock
		MAG:DT A	Interface A, Magstripe data
		MAG:GND	Signal ground #1
		MAG:CK B	Interface B, Magstripe clock (IF_DIP:7 OFF) Interface A, Card load (IF_DIP:7 ON)
		MAG:DT B	Interface B, Magstripe data
Max cable length	100 m (depending on properties of receiving system)		
Wire size	0.5 mm <sup>2</sup> (AWG 20), 1.5 mm <sup>2</sup> (AWG 16) above 10 m of length.		
Voltage	Typ 5 V / Max 30 V		
Sink current	Max 500 mA		
Isolation	Min 1500 VDC		

**Table 5 Wiegand connection overview**

The Wiegand/Magstripe signals can be internally pulled up to 5 V with 1 kΩ resistors. Pull-ups are activated using DIP switches S301:6-8 on XT Mini and XT-1 and IF\_DIP:6 on XT-5 and XT-5 ETC.

All Wiegand/Magstripe settings are available under Settings.../Interfaces.../Wieg/Mag in the web interface. It is possible to select a predefined format or define a custom format.

The most common predefined formats can be selected by setting SW\_DIP/S101:5-8 as shown in the table below. When any of these switches are in the ON position, the reader is also configured to report tags once and only accept SecureMarkID tags.

The following formats can be selected by DIP switches:

- D = Data from tag (bit for Wiegand/digit for Magstripe)
- S = Value of Site code
- E = Even parity bit, O = Odd parity bit, X = Bit included in parity calculation
- B = Magstripe start character, F = Magstripe stop character, L = Magstripe LRC

Output Format	Description
<b>W26S/H10301</b> SW_DIP/S101 	26-bit Wiegand (8-bit site code, 16-bit data):  ESSSSSSSSDDDDDDDDDDDDDDDDDDO XXXXXXXXXXXXXXXX----- -----XXXXXXXXXXXXXXXXX
<b>W26N/H10301</b> SW_DIP/S101 	26-bit Wiegand (24-bit data, no site code):  EDDDDDDDDDDDDDDDDDDDDDDDDDDO XXXXXXXXXXXXXXXX----- -----XXXXXXXXXXXXXXXXX
<b>W34N</b> SW_DIP/S101 	34-bit Wiegand (32-bit data, no site code):  EDDDDDDDDDDDDDDDDDDDDDDDDDDDDO XXXXXXXXXXXXXXXXXXXX----- -----XXXXXXXXXXXXXXXXXXXXX
<b>W37N/H10302</b> SW_DIP/S101 	37-bit Wiegand (35-bit data, no site code):  EDDDDDDDDDDDDDDDDDDDDDDDDDDDDDDO XXXXXXXXXXXXXXXXXXXXXXXX----- -----XXXXXXXXXXXXXXXXXXXXX
<b>W37R/H10302</b> SW_DIP/S101 	37-bit Wiegand (37-bit data, no site code, no parity):  DDDDDDDDDDDDDDDDDDDDDDDDDDDDDDD
<b>M8N/H10320</b> SW_DIP/S101 	8-digit Magstripe:  [ 25 zeroes ]BDDDDDDDFL[ 165 zeroes ]

Table 6 Wiegand/Magstripe formats



### 3.4.1 Wiegand Timing

The following values apply when all outputs are pulled up to 5 V with 1 kΩ resistors.

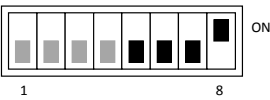
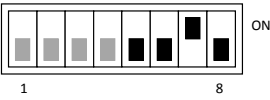
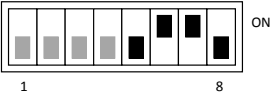
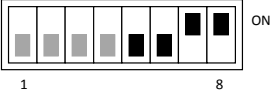
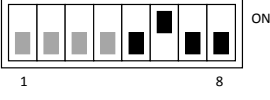
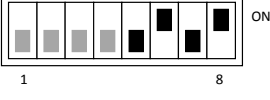
Symbol	Parameter	Min	Typ	Max	Unit
$t_{SU}$	CL to D# setup time		1520		μs
$t_F$	Fall time (all signals)		125		ns
$t_R$	Rise time (all signals)		5		μs
$t_{PI}$	Pulse interval		2		ms
$t_{PW}$	Pulse width		80		μs
$t_H$	CL hold time after last D# change		1840		μs

Table 7 Wiegand interface timing

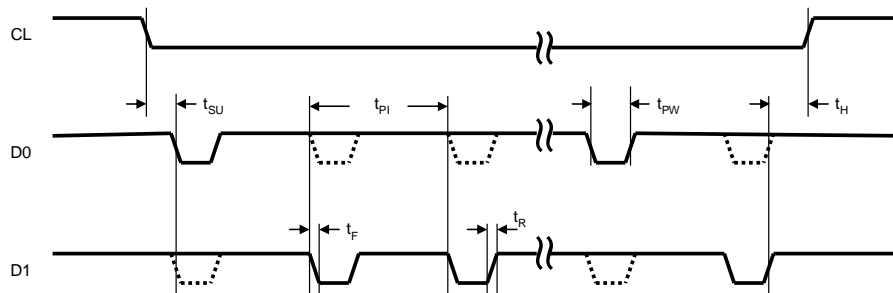

Figure 12 Wiegand timing diagram

### 3.4.2 Magstripe Timing

The following values apply when all outputs are pulled up to 5 V with 1 kΩ resistors.

Symbol	Parameter	Min	Typ	Max	Unit
$t_{SU}$	LOAD to CLK setup time		1520		μs
$t_F$	Fall time (all signals)		125		ns
$t_R$	Rise time (all signals)		5		μs
$t_{CL}$	Clock low		480		μs
$t_{CH}$	Clock high		960		μs
$t_H$	LOAD hold time after last CLK change		1520		μs
$t_{DH}$	Data hold time		880		μs

Table 8 Magstripe interface timing

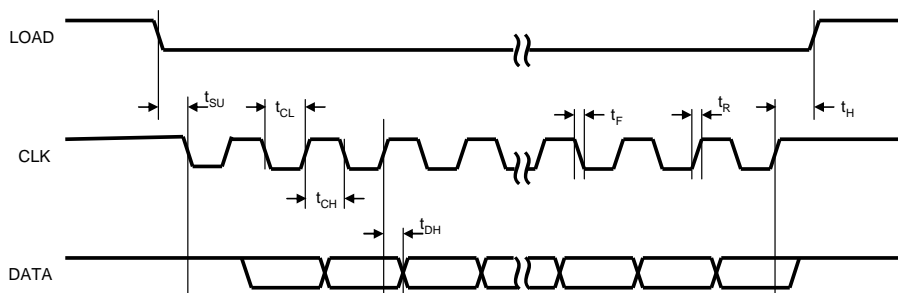

Figure 13 Magstripe timing diagram (note: data low = logic one)

### 3.5 Status Indicators

The readers have status indicators that are visible on the controller board and on the XT-5 ETC lid.

Indicator	Description
POWER	Flashing - Reader is powered and firmware is running On - Reader is powered but the firmware is not running Off - Reader is now powered
ETH LINK A/B	Flashing - Activity On - Link detected Off - No link detected
ETH SPEED A/B	On - 100 Mbit/s Off - 10 Mbit/s
ANTENNA 1-4 (XT-5, XT-5 ETC)	Flashing - Reading tags On - Antenna active (CARRIER = ON) Off - Antenna inactive/not present (CARRIER = OFF)

The status indicators on XT-5 and XT-5 ETC are shown in Figure 14. In XT Mini and XT-1, the POWER indicator is a single green LED and the Ethernet indicators, ETH LINK and ETH SPEED, are yellow and green LEDs mounted on or close to the Ethernet port(s).

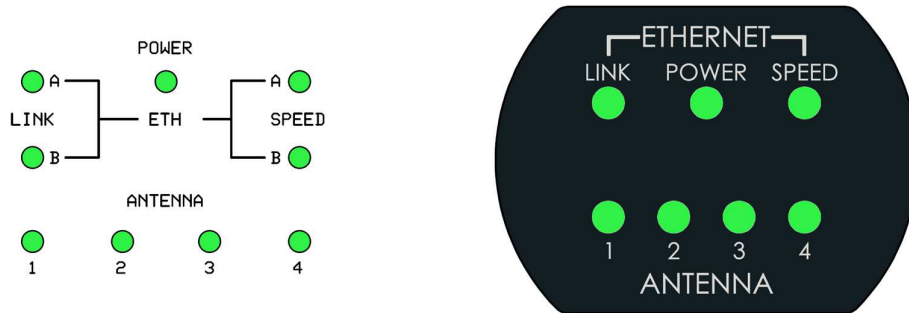

Figure 14 Status indicators on XT-5/XT-5 ETC controller board and XT-5 ETC lid

### 3.6 RS232

The RS232 interface can be used for communication with a host system.

Connections	RS232:TXD	Transmitted data to host
	RS232:RXD	Received data from host
	RX232:GND	Signal ground #2
Max cable length	10 m	
Wire size	Specification according to EIA RS232C. Belden 9184 or Belden 9502 are recommended.	
Max Baud rate	115.2 kb/s (default)	

Table 9 RS232 connection overview

The default output of the RS232 interface is tag data in ASCII format. If SecureMarkID® tags from TagMaster are being used (recommended) the numeric identity is sent out. If other EPC tags are being used the default output is the EPC data. The data is followed by CR+LF ("\r\n").

A TAGP connection can be initiated by sending the HELOTAGP message to the reader. The TAGP connection is terminated with the QUIT message. Other protocols can be enabled using the web interface. These protocols are described in separate manuals.

All RS232 settings are available under Settings.../Interfaces.../RS232 in the web interface.

### 3.7 RS485

The RS485 interface can be used for communication with a host system.

Connections	RS485:TX+	Transmitted data to host
	RS485:TX-	Transmitted data to host
	RS485:GND	Signal ground #3
	RS485:RX+	Received data from host
	RS485:RX-	Received data from host
Max cable length	1000 m	
Wire size	The cable for the RS485 interface must be a twisted pair cable and conform to the EIA RS485 standard.	
Max Baud Rate	115.2 kb/s (default)	

**Table 10 RS485 connection overview**

The hardware supports 2-wire (IF\_DIP/S301:1-2 ON) and 4-wire communication, half duplex and full duplex as well as multi-drop. When using RS485 communication, correct termination of the interface should be considered in order to handle transmission-line effects. The readers have a built-in option (IF\_DIP/S301:3 ON) of 120 Ω termination on the receive side (to be used at each end of the RS485 chain), and an option (IF\_DIP/S301:4-5 ON) of 620 Ω bias on the receive side (to be used at one node in the RS485 chain). The options using DIP switches are detailed in Figure 15 and also described in section 3.15.

With factory default settings, the reader should always be configured in 4-wire mode (IF\_DIP/S301:1-2 OFF) since the TAGP protocol requires a full-duplex link. Other protocols require different settings.

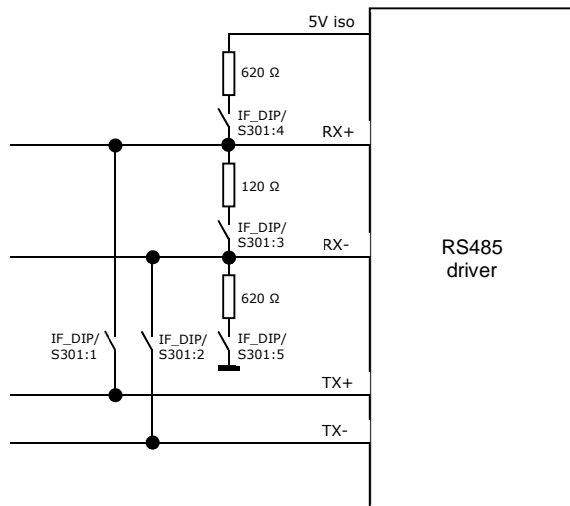

**Figure 15 RS485 DIP switch configuration**

The default output of the RS485 interface is tag data in ASCII format. If SecureMarkID® tags from TagMaster are being used (recommended) the numeric identity is sent out. If other EPC tags are being used the default output is the EPC data. The data is followed by CR+LF ("\\r\\n").

A TAGP connection can be initiated by sending the HELOTAGP message to the reader. The TAGP connection is terminated with the QUIT message. Other protocols can be enabled using the web interface. These protocols are described in separate manuals.

All RS485 settings are available under Settings.../Interfaces.../RS485 in the web interface.

### 3.8 Inputs

The reader has three (XT-1 and XT Mini) or four (XT-5 and XT-5 ETC) opto-coupled inputs.

Connections	All models	INPUTS:IN1+	Input 1 positive terminal
		INPUTS:IN1-	Input 1 negative terminal
		INPUTS:IN2+	Input 2 positive terminal
		INPUTS:IN2-	Input 2 negative terminal
		INPUTS:IN3+	Input 3 positive terminal
		INPUTS:IN3-	Input 3 negative terminal
	XT-5, XT-5 ETC	INPUTS:IN4+	Input 4 positive terminal
		INPUTS:IN4-	Input 4 negative terminal
High Voltage (active)		Min 3.0 V / Max 30 V	
Low Voltage (inactive)		Min 0.0 V / Max 0.2 V	
Input impedance		1 kΩ	
Max cable length		100 m	
Wire size		0.5 mm <sup>2</sup> (AWG 20)	

**Table 11 Input connection overview**

The inputs are activated by a current flow and the input impedance is 1 kΩ. A schematic view of an input is shown in Figure 16.

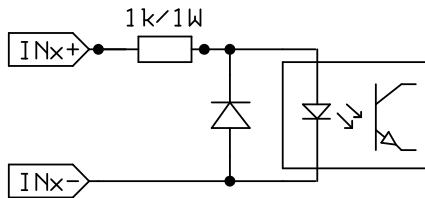

**Figure 16 Input schematic**

The first two inputs can be used to control the green and red LED from an external access control system to indicate if access has been granted or denied. The third input can be used as a read enable/disable input. This input can be connected to an external presence detector such as an inductive loop to make sure that the reader only reads tags when a vehicle is present.

All inputs have a debounce filter that is enabled by default. When the debounce filter is enabled, short pulses on the inputs are ignored. Pulses must be at least 20 ms to guarantee that they are detected. The polarity of the inputs can be inverted to cope with signals that are active high or active low.

The read enable/disable input can be configured to work in different modes. "Read time" is used to specify how long time reading should be enabled after it has been activated by the input. If read time is zero, reading is enabled as long as the input is active. The "Abort after read" setting can be used to abort reading after a single tag has been read (read time must be non-zero for this setting to have any effect). The "Indicator" setting is used to specify the colour of the LED when reading is enabled.

All input settings are available under Settings.../Interfaces.../Inputs in the web interface.

### 3.9 Light and Sound

Reader antennas (built-in and external) have a bright multi-colour LED indicator. The LED indicator can show when a tag has been read and if access has been granted or denied.

A built-in buzzer can give an audible indication when a tag has been read or settings have been changed.

### 3.10 Relay

The relay output can be used to control a barrier, gate, or other object. The relay can either be activated when any tag has been read or when an accepted tag has been read. A tag is considered accepted when it is listed in the built-in access controller's database. The active time can be configured.

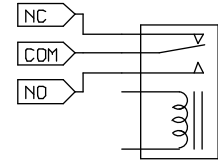

Figure 17 Inactive relay

Connections	RELAY:COM	Common
	RELAY:NO	Normally Open
	RELAY:NC	Normally Closed
Switching current	Max 2 A	
Switch voltage	Max 60 VDC / 30 VAC	
Switching capacity:	Max 60 W / 62,5 VA	
Max cable length	100 m	
Wire size	0.5 mm <sup>2</sup> (AWG 20)	

Table 12 Output connection overview

Relay settings are available under Settings.../Interfaces.../Relay in the web interface.

### 3.11 MicroSD Memory Card Slot

The reader is equipped with a microSD memory card slot for additional storage.

Connections	MICROSD
-------------	---------

In XT Mini and XT-1, the microSD card is needed to use the built-in access controller and logging functionality. Information about the currently inserted microSD card can be found under Settings.../Interfaces.../MicroSD in the web interface. On this page it is also possible to format the microSD card.

In XT-5 and XT-5 ETC, the microSD card can be used from the Linux system.

### 3.12 USB Device

The readers have a USB device interface that can be used for service and maintenance.

Connections	USB DEV	
USB connector	Type B Jack	
Speed	XT Mini, XT-1	12 Mbit/s (Full Speed)
	XT-5, XT-5 ETC	480 Mbit/s (Hi-Speed)

### 3.13 USB Host (XT-5, XT-5 ETC)

XT-5 and XT-5 ETC have a USB host interface that can be used from the Linux system.

Connections	USB HOST	
USB connector	Type A Jack	
Speed	XT Mini, XT-1	12 Mbit/s (Full Speed)
	XT-5, XT-5 ETC	480 Mbit/s (Hi-Speed)

### 3.14 Tamper Switch (XT Mini, XT-5, XT-5 ETC)

XT Mini, XT-5 and XT-5 ETC have a tamper switch that can be connected to an external alarm loop. The circuit is opened when the lid is opened.

Connections	XT Mini	TMP:TMP A	Tamper switch connection 1
		TMP:TMP B	Tamper switch connection 2
	XT-5, XT-5 ETC	TAMPER:TMP A	Tamper switch connection 1
		TAMPER:TMP B	Tamper switch connection 2

### 3.15 DIP Switches

Two 8-position DIP switches are available for interface and software configuration.

#### 3.15.1 Interface Configuration DIP Switch (IF\_DIP/S301)





Position(s)	Description
1-2 	<b>RS485 2-wire mode</b> IF_DIP/S301:1 ON = TX+ connected to RX+ IF_DIP/S301:2 ON = TX- connected to RX-
3 	<b>RS485 termination</b> IF_DIP/S301:3 ON = 120 Ω termination between RX+ and RX-. Termination should be activated at each end of an RS485 chain.
4-5 	<b>RS485 bias</b> IF_DIP/S301:4 ON = 620 Ω pull-up from RX+ to 5 V IF_DIP/S301:5 ON = 620 Ω pull-down from RX- to 0 V Bias should be activated at one node in an RS485 chain.
6-8 (XT Mini, XT-1) 	<b>Wiegand/Magstripe pull-ups</b> S301:6 ON = 1 kΩ pull-up from D0/CLK to 5 V S301:7 ON = 1 kΩ pull-up from D1/DATA to 5 V S301:8 ON = 1 kΩ pull-up from CL/LOAD to 5 V Pull-ups should be activated when the reader is connected to an access control system without built-in pull-ups.
6 (XT-5, XT-5 ETC) 	<b>Wiegand/Magstripe pull-ups</b> IF_DIP:6 ON = 1 kΩ pull-ups to 5 V on all Wiegand/Magstripe signals Pull-ups should be activated when the reader is connected to an access control system without built-in pull-ups.
7 (XT-5, XT-5 ETC) 	<b>Wiegand/Magstripe single/dual</b> IF_DIP:7 ON = Single Wiegand/Magstripe interface (A) with D0/CK B = CL/LOAD
8 (XT-5, XT-5 ETC) 	<b>Reserved for future use</b>

Table 13 Interface Configuration DIP Switch (IF\_DIP/S301)

### 3.15.2 Software Configuration DIP Switch (SW\_DIP/S101)

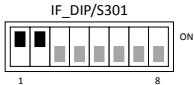
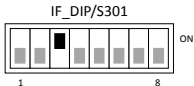

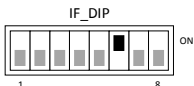

Position(s)	Description
<p>1</p> 	<p><b>Firmware upgrade mode</b></p> <p>SW_DIP/S101:1 is used for complete firmware upgrade and should normally not be used. See section 4.4 for information about normal firmware upgrade.</p>
<p>2</p> 	<p><b>Factory defaults</b></p> <p>SW_DIP/S101:2 is used to restore the reader to factory default settings. See section 4.5 for more information.</p>
<p>3</p> 	<p><b>Fixed IP address</b></p> <p>SW_DIP/S101:3 forces the reader to use the following IP settings:</p> <p>IP address: 169.254.1.1                      Netmask: 255.255.0.0</p> <p>A Windows PC that is directly connected to a reader is normally automatically assigned an IP address in the 169.254.x.x range. This means that it is possible to connect to a reader without changing IP settings on the PC. It may be necessary to run "ipconfig /release" if the PC has received IP settings over DHCP.</p>
<p>4</p> 	<p><b>Force boot loader</b></p> <p>SW_DIP/S101:4 forces the reader to start its boot loader at power up. See section 4.4 for more information.</p>
<p>5-8</p> 	<p><b>Easy configuration</b></p> <p>SW_DIP/S101:5-8 are used for easy configuration of Wiegand/Magstripe, OSDP, and other settings. See sections 5.1.1 and 5.2.1 for more information.</p>

Table 14 Software Configuration DIP Switch (SW\_DIP/S101)

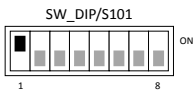

## 4 Configuration

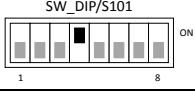
### 4.1 Web Interface

The readers have a web interface for configuration and maintenance. The web interface is designed and tested to work with modern versions of Google Chrome and other web browsers.

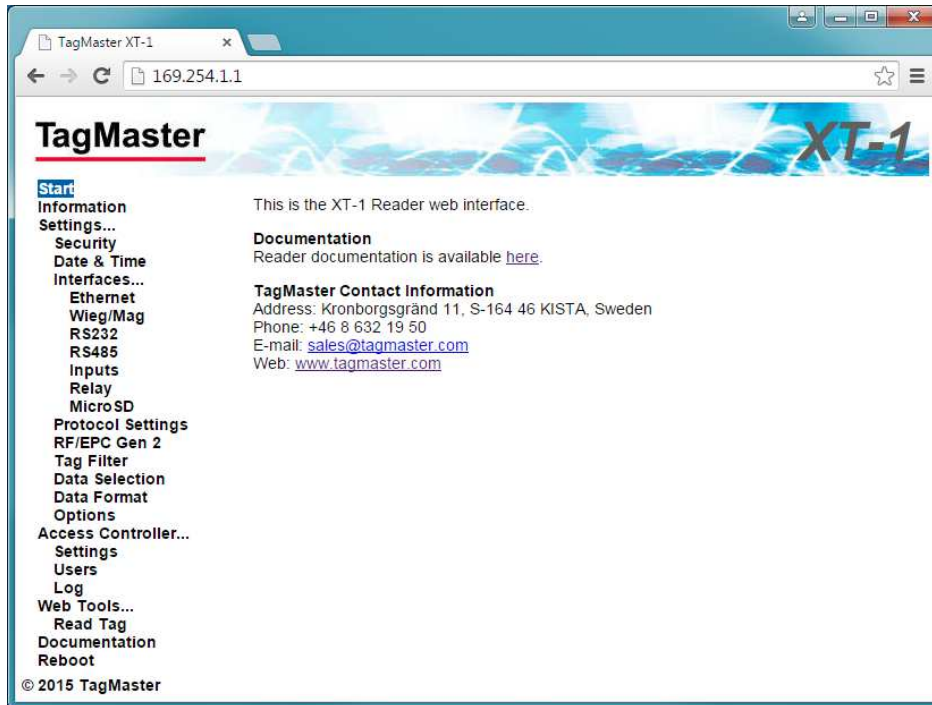

Figure 18 Web interface with expanded menu

Connect to the web interface by entering the reader's IP address in the web browser's address bar.

For XT Mini and XT-1, the reader's default IP address and subnet mask can be found on a label on the backside of the reader. The default address is on the format 10.x.x.x and the subnet mask is 255.0.0.0. The XT-5 and XT-5 ETC readers are by default configured to get IP settings from a DHCP server. If no DHCP server is available, these readers will auto-assign an IP address in the range 169.254.x.x/16.

For convenience it is possible to force the reader to use a fixed IP address by setting SW\_DIP/S101:3 to ON before starting the reader. The IP address will then be 169.254.1.1 and the subnet mask 255.255.0.0. A PC that is directly connected to a reader will usually get an IP address in this subnet automatically.

If the PC does not have an IP address that is in the same subnet as the reader it is necessary to change the PC's address. In Windows 7, this is done using "Network and Sharing Center" in "Control Panel". Click on "Local Area Connection", "Properties", "TCP/IPv4", and "Properties". Select "Use the following IP address" and fill in "IP address" and "Subnet mask".

Note that the web interface may look slightly different depending on the version of the firmware in the reader. Up-to-date documentation is always available under "Documentation" in the web interface menu.

#### 4.1.1 Start

The "Start" page provides TagMaster contact information.

#### 4.1.2 Information

The "Information" page provides information about the system.

### 4.1.3 Settings...

All configuration of the reader can be done on the "Settings..." pages. For all settings, it is possible to get help by clicking on the question mark (?). Click the "Save Settings" button to activate changed settings. Click the "Factory Defaults" button to restore all settings on a page to factory defaults.

Information about important settings is available in the following sections.

### 4.1.4 Access Controller...

The built-in access controller is configured on the "Access Controller..." pages. See section 6 for more information.

### 4.1.5 Web Tools...

The "Web Tools..." pages contain tools that are useful during installation and testing.

#### 4.1.5.1 Read Tag

The "Read Tag" page makes it easy to read tags and display tag contents.

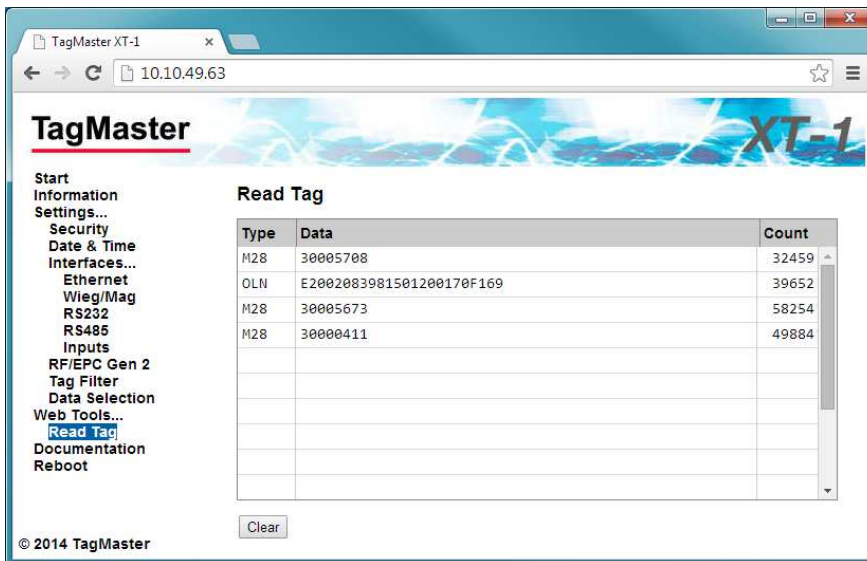

Figure 19 Read Tag

### 4.1.6 Documentation

The Documentation page provides up-to-date reader documentation.

### 4.1.7 Reboot

The Reboot page makes it easy to reboot the reader.

- Press the "Reboot" button to initiate a reboot.

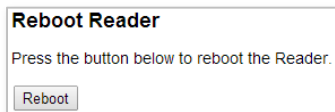

- Wait for the reboot to complete.

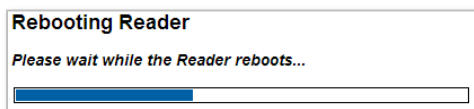

## 4.2 Region

To meet different radio regulations around the world, the reader can be configured to work in different regions. Each reader model comes in two versions: EU and US. Each reader version supports a number of regions as listed in the table below. Default values are shown in bold.

The region can be changed under Settings.../RF/EPC Gen 2 in the web interface.

Reader Version	Supported Regions
EU	<b>Europe</b> , India
US	<b>United States</b> , Australia, China, Indonesia, Malaysia, New Zealand, Thailand

Table 15 Supported regions

## 4.3 Tag Reading

By default, the reader reads tags with maximum read range and outputs tag data in a way that is suitable for most applications. If necessary, the tag reading process is highly configurable. Most settings controlling tag reading are available under Settings.../RF/EPC Gen 2 in the web interface.

RAIN RFID readers manage tag populations using the three basic operations: select, inventory, and access. The reader automatically performs all of these when the "Carrier" setting is on. The tag reading process is shown in Figure 20 and described in the following sections.

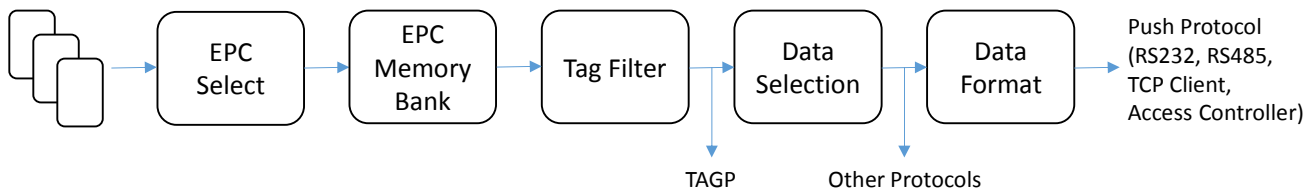

Figure 20 Reading tags

### 4.3.1 Carrier and Read Level

The "Carrier" setting is used to enable/disable reading. When Carrier is on (default) the reader reads tags.

The "Read level" setting controls the read range. The default value 100 corresponds to maximum read range.

### 4.3.2 EPC Select

The "EPC select" setting defines which tags the reader will talk to. Selection is done by specifying a binary value and a part of tag memory that must match the value. Only tags that match will respond to the reader's query. The default value "\*" selects all tags.

### 4.3.3 EPC Memory Bank/Custom Format

The settings "EPC memory bank" and "EPC custom format" specifies which parts of the tag memory that will be read by the reader. Available options include EPC/SecureMarkID (default), SecureMarkID, EPC, TID and "Custom Format".

If "EPC memory bank" is set to "Custom Format" the "EPC custom format" setting specifies which parts of the tag memory that will be read.

### 4.3.4 Tag Filter

The tag filter (under Settings.../Tag Filter in the web interface) specifies how often tags are reported. Tags can be reported every time they are read, periodically or once. It is also possible to get a tag event when a tag is no longer read by the reader. It is possible to activate read beep and read blink to get an indication every time a tag is reported.

The TAGP protocol reports tag events as they come out of the tag filter.

### 4.3.5 Data Selection

The "Data selection" settings (under Settings.../Data Selection in the web interface) specifies how the read data shall be interpreted (binary, hexadecimal or decimal) and also makes it possible to select a part of the data (number of digits with a left or right aligned offset).

Reader protocols with binary output reports data as it comes out of this stage.

### 4.3.6 Data Format

The "Data Format" settings (under Settings.../Data Format in the web interface) specifies the output format for data that is pushed to RS232, RS485, TCP Client, and the built-in access controller.

## 4.4 Firmware Upgrade

Download the latest firmware from <ftp://partner:245ghz@ftp.tagmaster.com/Vigilant/Firmware>.

Go to the "Reboot/Upgrade" page on the web interface, check "Start boot loader" and press the "Reboot" button to start the boot loader. In the boot loader, press "Choose File" and choose the downloaded firmware file. Press "Upgrade" to start the upgrade and then press "Reboot" when the upgrade has finished.

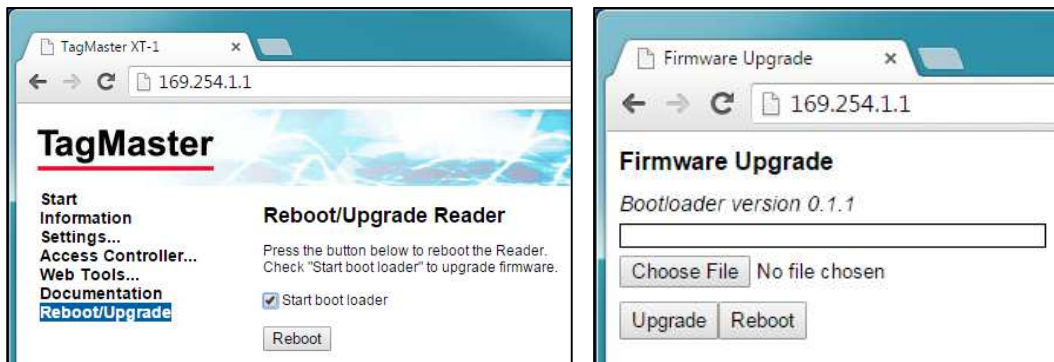

Figure 21 Starting the boot loader to upgrade firmware

Note: The boot loader was added in firmware version 1.2.0. To upgrade from earlier versions, follow the instructions in the README document that is available in the same FTP directory as the firmware.

## 4.5 Factory Defaults

Use the following procedure to restore the reader to factory default settings:

1. Set SW\_DIP/S101:2 to ON

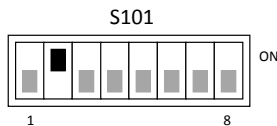

2. Power cycle the reader
3. Set SW\_DIP/S101:2 back to OFF

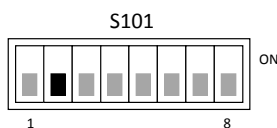

## 5 Connecting to an External System

The following sections describe how to connect the reader to another system. Note that the reader requires more power than a typical proximity reader and should have its own power supply.

### 5.1 Wiegand/Magstripe

The reader can be connected to a typical access control system using Wiegand/Magstripe. The access control system can control the reader's LED indicator using inputs IN1 and IN2. Input IN3 can be connected to a presence detector such as an inductive loop. An overview is shown in Figure 22.

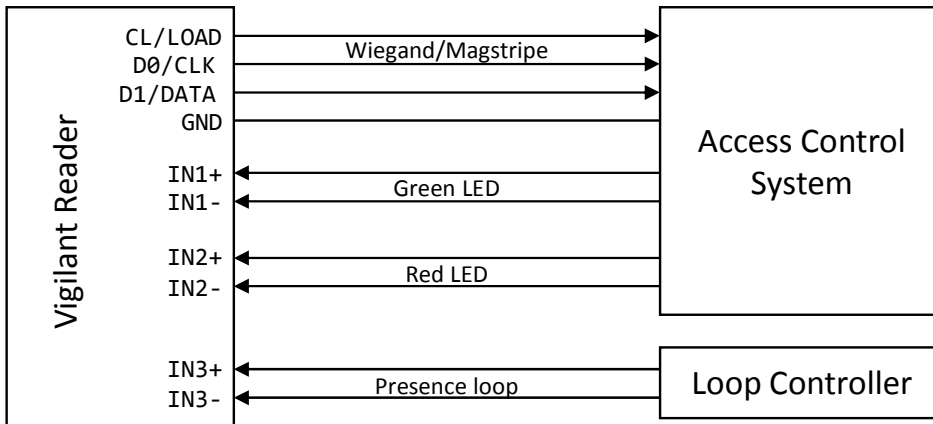

Figure 22 Reader connected to access control system using Wiegand/Magstripe

For common access control systems, the reader can be configured using DIP switches as described in section 5.1.1, "Easy Configuration", below. For other systems, all Wiegand/Magstripe settings are available under Settings.../Interfaces.../Wieg/Mag in the web interface.

#### 5.1.1 Easy Configuration

The reader can be configured to work with common access control systems using SW\_DIP/S101:5-8. When any of these switches are in the ON position, the reader is configured to report tags once, accept SecureMarkID tags only, and use the specified Wiegand/Magstripe format.

The following sections describe how to connect the reader to different access control systems and how to set the reader's DIP switches. The following format is used to describe cable connections:

[READER SIGNAL] → [ACCESS CONTROL SYSTEM SIGNAL]

##### 5.1.1.1 ASSA ARX/RX WEB (with 500RW22)

Configure the ARX/RX WEB system to use card type Wiegand.

GND → 0V	IN1+ → 12V
CL/LOAD → N/C	IN1- → LED_GREEN
D0/CLK → D0	IN2+ → 12V
D1/DATA → D1	IN2- → LED_RED
SW_DIP/S101 - Wiegand format: W34N	IF_DIP/S301 - Vigilant pull-ups disabled

Tested version: RX WEB PR300233 build-8418 version-17.2.0.5

5.1.1.2 **AXIS A1001**

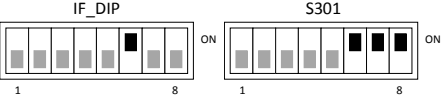

Configure A1001 to use reader protocol Wiegand with "Dual LED" and set the card format to H10302.

GND → [READER I/O] -	IN1+ → [READER I/O] 12V
CL/LOAD → N/C	IN1- → [READER I/O] I05
D0/CLK → [READER DATA] D0	IN2+ → [READER I/O] 12V
D1/DATA → [READER DATA] D1	IN2- → [READER I/O] I04
SW_DIP/S101 - Wiegand format: W37N/H10302 	IF_DIP/S301 - Vigilant pull-ups enabled 

Tested version: Firmware version 1.30.0

5.1.1.3 **Bewator Entro**

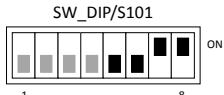
Configure the Bewator Entro system to use H10302 format.

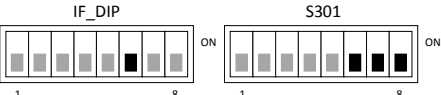
GND → 0V	IN1+ → N/C
CL/LOAD → N/C	IN1- → N/C
D0/CLK → D0/CLK	IN2+ → N/C
D1/DATA → D1/DATA	IN2- → N/C
SW_DIP/S101  Bewator Entro ≥ 6.5: Wiegand format: W37N/H10302   Older versions: Wiegand format: W37R/H10302	IF_DIP/S301 - Vigilant pull-ups disabled 

Tested version: Bewator Entro 6.55.011

5.1.1.4 **Bewator Omnis (with E2V)**

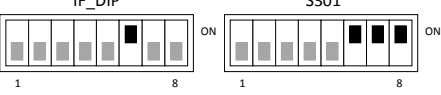

The Vigilant reader behaves as a RB500 reader in Clock&Data mode.

GND → [Conn. G] -	IN1+ → [Conn. G] +12V
CL/LOAD → [Conn. E] A	IN1- → [Conn. G] G
D0/CLK → [Conn. E] B	IN2+ → [Conn. G] +12V
D1/DATA → [Conn. E] C	IN2- → [Conn. E] R
SW_DIP/S101 - Magstripe format: M8N/H10320 	IF_DIP/S301 - Vigilant pull-ups enabled 

Tested version: Bewator Omnis 6.0.107

**5.1.1.5 Paxton Net2 Plus**

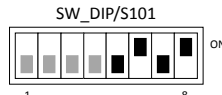

Configure the Paxton system to use reader type "Clock & Data".

GND → 0V	IN1+ → 12V
CL/LOAD → N/C	IN1- → Green LED
D0/CLK → Clock/D1	IN2+ → 12V
D1/DATA → Data/D0	IN2- → Red LED
SW_DIP/S101 - Magstripe format: M8N/H10320 	IF_DIP/S301 - Vigilant pull-ups disabled 

Tested version: Net2 Lite version 4.28.8417

**5.1.1.6 RCO R-CARD M5 (with DB-50W)**

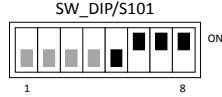
The RCO system automatically detects the Wiegand format.

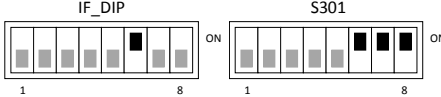
GND → DC-	IN1+ → N/C
CL/LOAD → N/C	IN1- → N/C
D0/CLK → DATA0	IN2+ → N/C
D1/DATA → DATA1	IN2- → N/C
SW_DIP/S101  Strap at P14*: Wiegand format: W34N   No strap at P14: Wiegand format: W26S/H10302	IF_DIP/S301 - Vigilant pull-ups enabled 

\* To get all digits from the SecureMarkID tag, it is necessary to solder a strap at P14 on the RCO DB-50W board. Without this strap it is only possible to get the last four digits from the tag.

**5.1.1.7 Vanderbilt Aliro**

On the circuit board in the access point, set the EOL jumper for the reader to OFF. In the Aliro software, set reader type to "Wiegand" and card format to "H10302\_37". Configure Output\_1 to "C&D/Wiegand green" and Output\_2 to "C&D/Wiegand red".

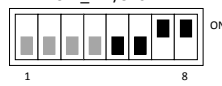
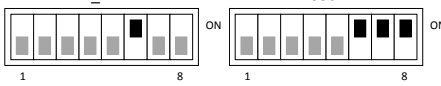
GND → [READER n] -	IN1+ → [READER n] +
CL/LOAD → N/C	IN1- → [OUT 1/2 ] 1
D0/CLK → [READER n] A	IN2+ → [READER n] +
D1/DATA → [READER n] B	IN2- → [OUT 1/2 ] 2
SW_DIP/S101 - Wiegand format: W37N/H10302 	IF_DIP/S301 - Vigilant pull-ups enabled 

Tested version: Software version 1.0.0.5371, Access point firmware version 1.0.0.2022



## 5.2 OSDP (RS485)

The reader supports the Open Supervised Device Protocol (OSDP) [5] for connection to access control systems. OSDP communicates over 2-wire RS485 and can therefore be used with long cables and does not require extra cables for LED and buzzer control. IF\_DIP/S301:1-2 must be set to ON to enable 2-wire mode on the reader. In most cases IF\_DIP/S301:3-5 should also be set to ON to enable biasing and termination. Input IN3 can be connected to a presence detector such as an inductive loop. Figure 23 shows a typical connection diagram and the most common settings for SW\_DIP/S101 and IF\_DIP/S301.

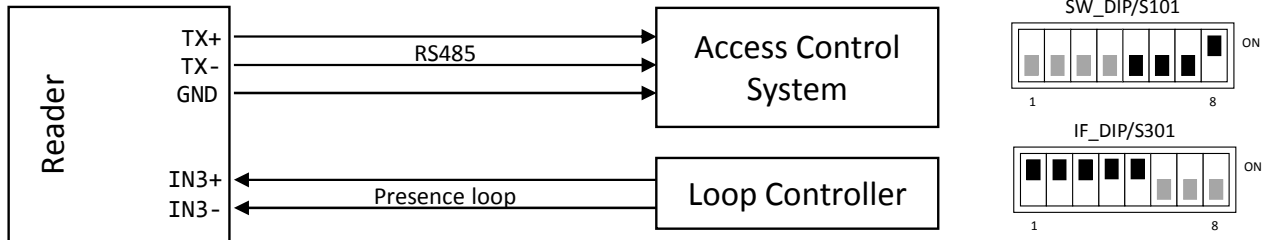

Figure 23 Reader connected to access control system using OSDP

All OSDP settings are available under Settings.../Protocol Settings.../OSDP. For common access control systems, OSDP can also be enabled using SW\_DIP/S101 as described below.

### 5.2.1 Easy Configuration

#### 5.2.1.1 Default OSDP Mode

Set SW\_DIP/S101 and IF\_DIP/S301 as shown in Figure 23.

##### 5.2.1.1.1 AXIS A1001

In the A1001 software, set the reader protocol to OSDP, RS485 half duplex. Define a new card format with name SecureMarkID and bit length 32. Set the field map like this: Name: CardNr, Range: 1-32, Encoding: BinLE2Int\*.

RS485:TX+ → [READER DATA n] B+	RS485:GND → [READER I/O n] -
RS485:TX- → [READER DATA n] A-	

Tested version: Firmware version 1.30.0

##### 5.2.1.1.2 Bravida Integra

In the Bravida Integra Software: Set the communication protocol for card reader to OSDP. In card reader, define proper card system. Set card data byte order to "MSB". Set device bus address to 1.

RS485:TX+ → PL400-3 +	RS485:GND → -
RS485:TX- → PL400-4 -	

Tested version: Integra SW version 7.0, C-NodeG2 FW version 21.70, S-NodeG2 FW version 20.20

##### 5.2.1.2 Vanderbilt Aliro



In the Aliro software, set reader type to "extended OSDP".

RS485:TX+ → [READER n] A	RS485:GND → [READER n] -
RS485:TX- → [READER n] B	
SW_DIP/S101 - Vanderbilt AR40S-MF emulation SW_DIP/S101 	IF_DIP/S301 - 2-wire RS485, bias and termination IF_DIP/S301 

Tested version: Software version 1.0.0.5371, Access point firmware version 1.0.0.2022

**5.2.1.3 Vanderbilt SiPass integrated - DRI Door Module**

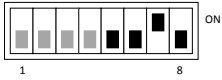
Set card technology to Siemens OSDP in FLN configuration tool.

RS485:TX+ → [Aux Serial] Tx +	RS485:GND → [Aux Serial] GND
RS485:TX- → [Aux Serial] Rx -	
SW_DIP/S101 - Vanderbilt AR40S-MF emulation 	IF_DIP/S301 - 2-wire RS485, bias and termination 

Tested version: Software SiPass 2.65 SP4, Firmware ADD5100 (DRI) version 3.42; ACC FW 2.65.51

**5.2.1.4 Vanderbilt SiPass integrated - ERI Door Module**

Set card technology to Siemens OSDP in FLN configuration tool.

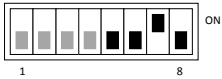
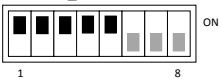
RS485:TX+ → [SRB RS485] +	RS485:GND → [SRB PWR] 0V
RS485:TX- → [SRB RS485] -	
SW_DIP/S101 - Vanderbilt AR40S-MF emulation 	IF_DIP/S301 - 2-wire RS485, bias and termination 

Tested version: Software SiPass 2.65 SP4, Firmware ADE5300 (ERI) version 3.38; ACC FW 2.65.51

### 5.3 Push (RS232, RS485, TCP/IP)

When a tag has been read, the reader can automatically push tag data to RS232, RS485 and a specified TCP server. The Push protocol is enabled by default on RS232 and RS485. To push data to a TCP server it is necessary to specify the IP address and TCP port of the server and enable the Push protocol under Settings.../Interfaces.../Ethernet in the web interface.

The format of the pushed data can be configured under Settings.../Data Format. The default format is decimal for SecureMarkID tags and hexadecimal for other tags.

### 5.4 TAGP (TCP/IP)

TagMaster Readers can be controlled and monitored using a protocol called TAGP. The TAGP protocol is human readable and can be used over TCP/IP, RS232 and RS485. A terminal emulation program such as PuTTY is all that is required to interact with TAGP.

The "TAGP Protocol Specification" [3] can be downloaded from [www.tagmaster.com](http://www.tagmaster.com). Use login name "partner" and password "245ghz".

PuTTY TagMaster Edition can be downloaded from <ftp://partner:245ghz@ftp.tagmaster.com>.

All TAGP messages start with a 4-character message identifier and ends with a new line character. To initiate communication with the TAGP server in the reader, a client has to send a HELO message specifying the required TAGP version. The TAGP server replies with a RPLY message:

```
HELOTAGP / 2
RPLYHELO00
```

The client can then send commands to the reader. The most important commands are SET, SETS, GET, and GETS. SET and GET sets and gets the current value of a variable. SETS and GETS sets and gets the stored value of a variable. The stored value is used to initialize the variable at startup. The following example shows how to set the LED to green:

```
SET LED=GREEN
RPLYSET 00
```

The reader sends events to the client when something happens. The following example shows a TAG event that is sent when a tag has been read:

```
EVNTTAG 20140416151015810%00%07'%141%00%00%00%00%00%00%00
```

### 5.5 Other Protocols

The reader supports a number of OEM protocols, including SKIDATA BLL4 and Kaba BPA/Bedanet. These protocols are documented in separate protocol manuals that can be downloaded from [www.tagmaster.com](http://www.tagmaster.com).

## 6 Built-in Access Controller

The reader has a built-in access controller that can control a barrier or gate using the reader's relay output. All accesses can be logged. A presence indicator such as an inductive loop can be connected to input 3.

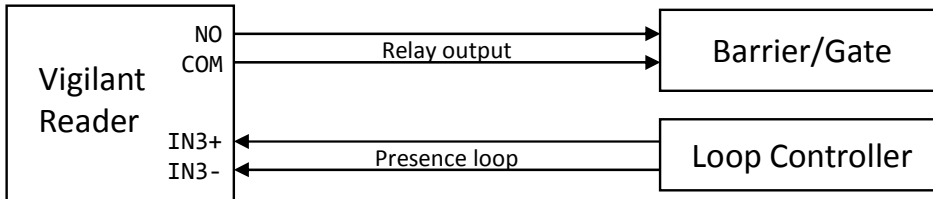

Figure 24 Built-in access controller connection diagram

With XT Mini and XT-1 it is necessary to insert a microSD card into the microSD memory card slot to use the access controller and/or log. Power off the reader before inserting or removing the microSD card!

The built-in access controller is configured using the web interface as shown in Figure 25.

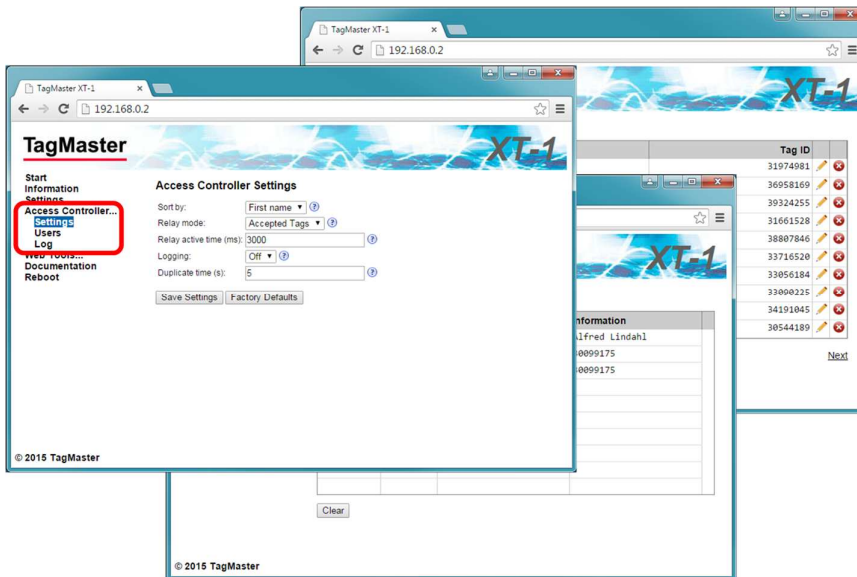

Figure 25 Built-in access controller web interface (Settings, Users, Log)

Max number of users	1000
Max number of log entries	1000

## 7 Troubleshooting

To facilitate troubleshooting, consider the following:

- Make sure that the reader has correct supply voltage and sufficient current. Check the POWER status indicator as described in section 3.5.
- If using Ethernet communication, make sure that the network connection is ok. Check the ETH LINK and SPEED status indicators as described in section 3.5.
- If the IP address has been forgotten or firmware settings have been corrupted the reader can be restored to factory default settings as described in section 4.5.
- Make sure that working and correctly formatted EPC Gen 2 tags are being used.

## 8 Definitions and Abbreviations

<b>AES</b>	Advanced encryption standard
<b>ASCII</b>	American standard code for information interchange
<b>AWG</b>	American wire gauge
<b>CR</b>	Carriage return
<b>DES</b>	Data encryption standard
<b>DIP</b>	Dual in-line package
<b>EPC</b>	Electronic product code
<b>FCC</b>	Federal communications commission
<b>LED</b>	Light emitting diode
<b>LF</b>	Line feed
<b>OEM</b>	Original equipment manufacturer
<b>RFID</b>	Radio-frequency identification
<b>PC</b>	Personal computer
<b>SecureMarkID®</b>	A TagMaster implementation for improved Security using EPC tags
<b>TAGP</b>	A TagMaster protocol for RFID reader communication
<b>TCP/IP</b>	An Internet protocol suite
<b>UMK</b>	Universal mounting kit
<b>USB</b>	Universal serial bus

## 9 References

- [1] [1117-129 XT-5 / XT-5 ETC DEVELOPER'S MANUAL](#)
- [2] [06-147 UMK 193600 DATA SHEET](#)
- [3] [05-172 TAGP PROTOCOL SPECIFICATION](#)
- [4] [EPC GEN 2 SPECIFICATION V.2.0.1, HTTP://WWW.GS1.ORG](#)
- [5] [SIA OPEN SUPERVISED DEVICE PROTOCOL, HTTP://WWW.SIAONLINE.ORG](#)

All documentation is available at <ftp://partner:245ghz@ftp.tagmaster.com/Documentation>.

## 10 Technical Specification

	XT Mini	XT-1	XT-5 / XT-5 ETC
Read range	Up to 3 m (10 ft)	Up to 8 m (26 ft)	Up to 12 m (40 ft)
Dimensions	261x152x55 mm (10.3x6.0x2.2 in)	300x300x60 mm (11.8x11.8x2.4 in)	
Weight	0.8 kg (1.8 lbs)	2.3 kg (5.1 lbs)	
Housing	UL94 certified plastic XENOY™	Aluminium housing UL94 certified XENOY™ cover	
Part No.	XT Mini eu: 152300 XT Mini us: 152400	XT-1 eu: 152500 XT-1 us: 152600	XT-5 eu: 152800 XT-5 us: 152900 XT-5 ETC: 153800
Output power	< 500 mW (e.r.p)	XT-1 eu: 2W (e.r.p.) XT-1 us: 4W (e.i.r.p.)	XT-5 eu: 2W (e.r.p.) XT-5 us: 4W (e.i.r.p.)
FCC ID	M39XTMX	M39XTXX	M39XTMEX
Power consumption	4W (max 5W)	10W (max 12W)	8W (max 12W)
Operating frequencies	EU: 865.6-867.6 MHz, US: 902-928 MHz		
Ingress protection	IP 66		
Operating temperature	-40°C to +60°C (-40°F to +140° F) EN 60068-2-1 Ad, EN 60068-2-2 Bd, EN 60068-2-14 Nb		
Storage temperature	-40°C to +85°C (-40°F to +185°F)		
Power supply	12-24 VDC, IEEE 802.3at PoE+ (XT-5 and XT-5 ETC)		
Inputs	3 (XT Mini and XT-1) or 4 (XT-5 and XT-5 ETC) isolated inputs		
Outputs	3 (XT Mini and XT-1) or 4 (XT-5 and XT-5 ETC) isolated outputs shared with Wiegand/Magstripe		
Relay	1 relay output 60VDC, 2A		
Interfaces	RS232, RS485, Wiegand/Magstripe (2 interfaces on XT-5 and XT-5 ETC), Ethernet (2-port switch on XT-1, XT-5, and XT-5 ETC, PoE+ on XT-5 and XT-5 ETC), microSD, USB device, USB host (XT-5 and XT-5 ETC), Tamper switches (XT Mini, XT-5, and XT-5 ETC)		
Certificates	CE Certificate according to R&TTE-directive 1999/5/EC and FCC RoHS Directive 2002/95/EC and 2011/65/EU WEEE 2002/96/EC		
Standards	EPC Gen 2, ISO 18000-63 (RAIN RFID)		
EMC	EN 301489-1, EN 301489-3		
Radio	EN 302 208-1, EN 302 208-2 FCC: CFR 47, Part 15 subpart C		
Safety & health	EN 60950-1, EN 60950-22 & 1999/519/EC		
Mechanical	EN 60068-2-27 Ea, EN 60068-2-64 Fh		
Manuals and documentation	13-111 XT Reader Manual 05-172 TAGP Manual		
Accessories	Universal Mounting Kit: 193600 ISO Card: 225000 WindShield Tag: 221000 HeadLight Tag: 227000		
Communication protocols	TAGP, OSDP, and various OEM protocols		



## **Technical Support**

Phone: +46 8 632 19 50

E-mail: [support@tagmaster.com](mailto:support@tagmaster.com)

## **Office Address**

TagMaster AB

Kronborgsgränd 11

164 46 KISTA

SWEDEN

Phone: +46 8 632 19 50

E-Mail: [sales@tagmaster.com](mailto:sales@tagmaster.com)

Web: [www.tagmaster.com](http://www.tagmaster.com)

**TagMaster**

---