

Alpha 600XJ Series

Industrial Radio Remote Control System

Operation & Parts Manual

Fomotech International Corp.

TABLE OF CONTENTS

1.	SAFETY INSTRUCTION	3
2.	PUSHBUTTON CONFIGURATION	
2.1	Alpha 604 Models	5
2.2	Alpha 607 & 608 Models	6
2.3	Alpha 612 Models	6
3.	TRANSMITTER OUTLINE	
3.1	Transmitter Outline	7
3.2	Alpha 604/607/608/612 Spare Parts	8
3.3	Battery Charger	8
4.	RECEIVER OUTLINE	
4.1	Alpha 604-608	9
4.1.1	Alpha 604-608 Models External Assembly	9
4.1.2	Alpha 604 Models Internal Assembly	10
4.1.3	Alpha 607/608 Models Internal Assembly	11
4.2	Alpha 612	12
4.2.1	Alpha 612 Models External Assembly	12
4.2.2	Alpha 612 Models External/Internal Assembly	13
4.3	α 604/ α 608/ α 612 Receiver Power Fuse List	14
5.	OUTPUT CONTACT DIAGRAMS	
5.1	Alpha 604 Models	14
5.2	Alpha 607 Models	15
5.3	Alpha 608 Models	16
5.4	Alpha 612 Models	17
6.	SYSTEM CONFIGURATIONS	
6.1	How to Set ID Codes	24
6.2	Transmitter Group Channel Settings.....	25
6.2.1	Group Channel Mode.....	25
6.2.2	Group Channel Settings.....	26
6.2.3	Fixed Channel Mode.....	26
6.2.4	Fixed Channel Mode Settings.....	27
6.3	Transmitter Channel Group Table/Frequency Display.....	27
7.	RECEIVER SETTING	
7.1	How to Set α 604/607/608 Receiver ID Codes	29
7.2	How to Set α 612 Receiver ID Codes	29
7.3	Receiving RF Module Pairing	30
7.4	Steps for Receiving RF Module to Pair with Transmitter.....	31
7.5	Receiver Function Settings	32
7.5.1	α 604/607/608 Receiver Function Settings	32
7.5.2	α 612 Receiver Function Settings	33
7.5.3	α 612 Models Dip-Switch Function Table	33
7.5.4	α 612 Receiver Voltage Settings	35
7.6	Frequency (RF) Range	35
8.	TRANSMITTER OPERATION & STATUS LIGHT	
8.1	Transmitter Operating Steps	36
8.2	Transmitter Status light	37

9.	RECEIVER INSTALLATION	
9.1	Preparation For Installation	38
9.2	Step-By-Step Installation and Commissioning.....	38
9.3	System Testing	39
9.4	Receiver System Status LED Display.....	40
10.	BATTERY CHARGER	
10.1	Charger Operation	42
10.2	Battery Charger LED Status Light	43
11.	TROUBLE SHOOTING.....	44
12.	SYSTEM SPECIFICATION	45
13.	PARTS LIST	47

1. SAFETY INSTRUCTION

The Alpha 600XS series are relatively simple to use, however, it is very important to observe the proper safety procedures before, during, and after operation. When used properly, the Alpha 600XS series will enhance safety, productivity and efficiency in the workplace.

The following procedures should be strictly followed:

1. The transmitter is equipped with an induction battery charger. Only two "AA" Ni-MH rechargeable batteries are allowed to be used in the transmitter. Please note the polarity of the batteries. Do not use other types of battery to prevent any accident.
2. Be sure to replace the batteries with the same brand and specification at the same time. Do not replace only one battery in the battery compartment otherwise there will have the condition of limited transmitter operating time, battery leakage and overheating when charging.
3. Do not place the battery charger under the raining, high temperature, humid and with corroded air environment. Indoor with good ventilation is suggested. Please also do not use the battery charger under 0°C.
4. It is prohibited that the high power wireless equipment such as walkie-talkie, wireless network transmitter,... etc. is closed to the transmitter or receiver as it might cause interference.
5. Do not change the IDs on transmitter encoder and receiver decoder boards at will.
6. Check the transmitter casing and pushbutton daily. Should any damage that could inhibit the proper operation of the transmitter be found the unit should be immediately removed from service.
7. Check the transmitter voltage whenever it is operated. Place the transmitter into battery charger when battery is running out or the voltage is low.
8. The red emergency stop button (EMS) should be checked at the beginning of each shift to ensure it is in proper working order and the "Stop" command is being received by the receiver.
9. In the event of an emergency press down the EMS button will immediately deactivates the receiver MAIN relay and the transmitter power. Then turned the power "off" from the main power source to the crane or equipment.
10. Notes within 300-meter of operation distance:

Please do not operate more than 20 units of α600XJ series at the same time or there might have some problems like: intermittent signal receipt, non-spontaneous movement, MAIN relay contact chattering ...etc. In case of several transmitters operated at the same time, please be sure to select different ID codes and channel groups to avoid interference.
11. Ensure the waist belt is worn at all time during operation to avoid accidental damage to the transmitter.
12. Rotate the power switch to OFF position when the transmitter is not operated temporarily or the operation is finished.
13. Any repair or adjustment should be proceeding by repair technician for radio remote controls.
14. The operator should not change any electrical parts at will.

Warning:

Changes or modifications are not expressly approved by the manufacturer could void the user's authority to operate the equipment.

"This transmitter(s)/receiver(s) complies with part 15 of the FCC Rules and Innovation, Science and Economic Development Canada's licence-exempt RSS(s).

Operation is subject to the following two conditions: (1) This device may not cause interference, and (2) this device must accept any interference, including interference that may cause undesired operation. "

"Le présent appareil est conforme aux CNR d'Industrie Canada applicables aux appareils radio exempts de licence. L'exploitation est autorisée aux deux conditions suivantes: (1) l'appareil ne doit pas produire de brouillage, et (2) l'utilisateur de l'appareil doit accepter tout brouillage radioélectrique subi, même si le brouillage est susceptible d'en compromettre le fonctionnement. "

2. PUSHBUTTON CONFIGURATION

2.1 Alpha 604 Models

1. Alpha604AJ-- (4) single speed pushbuttons
2. Alpha604BJ-- (4) double speed pushbuttons

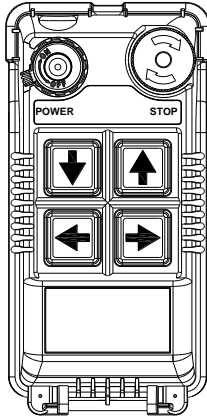

(Alpha604AJ)

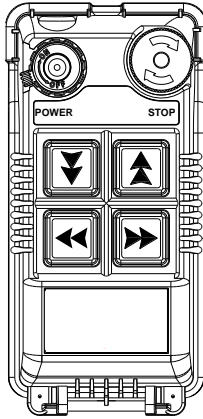

(Alpha604BJ)

Below are some of many types of pushbutton configurations that are also available, please contact your dealer for more details.

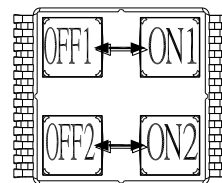
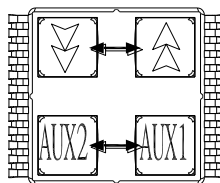
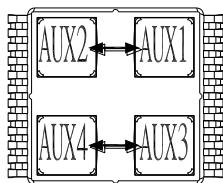
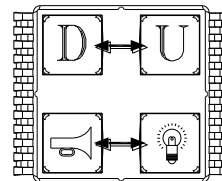
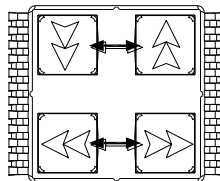
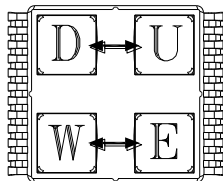

↔ Interlocked (Can also be set to non-interlocked via an external programmer unit).

2.2 Alpha 607 & 608 Models

1. Alpha 607AJ -- (7) single speed pushbuttons
2. Alpha 607BJ -- (6) double speed pushbuttons + (1) single speed pushbuttons
3. Alpha 607ATJ -- (6) single speed pushbuttons + (1) SELECT I/II pushbutton
4. Alpha 607BTJ -- (6) double speed pushbuttons + (1) SELECT I/II pushbutton
5. Alpha 608AJ -- (8) single speed pushbuttons
6. Alpha 608BJ -- (6) double speed pushbuttons + (2) single speed pushbuttons
7. Alpha 608ATJ -- (7) single speed pushbuttons + (1) SELECT I/II pushbutton
8. Alpha 608BTJ -- (6) double speed pushbuttons + (1) single speed pushbuttons+ (1) SELECT I/II pushbutton

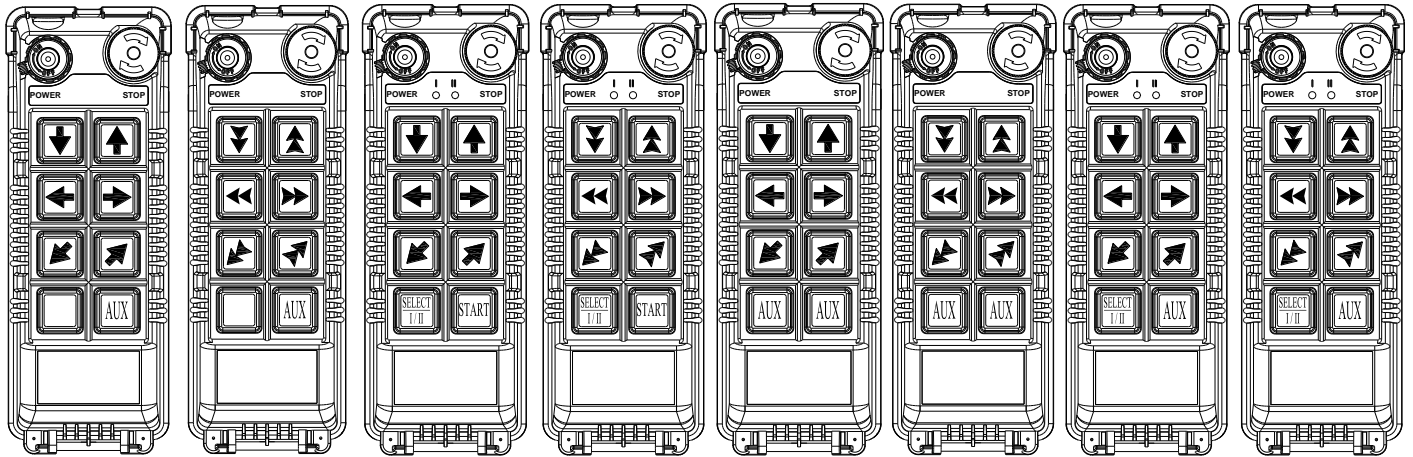

(Alpha 607AJ) (Alpha 607BJ) (Alpha 607ATJ) (Alpha 607BTJ) (Alpha 608AJ) (Alpha 608BJ) (Alpha 608ATJ) (Alpha 608BTJ)

2.3 Alpha 612 Models

1. Alpha 612AJ -- (12) one-speed pushbuttons
2. Alpha 612BJ -- (11) one-speed pushbuttons + I/II select pushbutton*
3. Alpha 612C-1J -- (6) two-speed + (6) one-speed pushbuttons
4. Alpha 612C-2J -- (8) two-speed + (4) one-speed pushbuttons
5. Alpha 612DJ -- (10) two-speed + (2) one-speed pushbuttons
6. Alpha 612E-1J -- (6) two-speed + (5) one-speed pushbuttons + I/II select pushbutton*
7. Alpha 612E-2J -- (8) two-speed + (3) one-speed pushbuttons + I/II select pushbutton*

* For cranes with auxiliary hoist and trolley (changeover function).

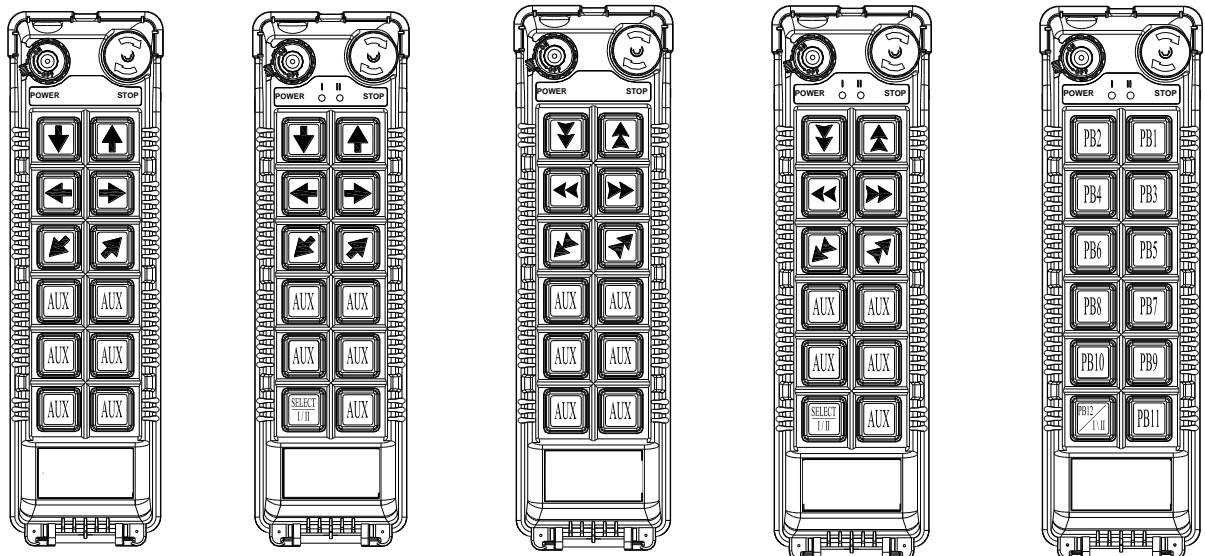

Alpha 612AJ

Alpha 612BJ

Alpha 612C-1J
Alpha 612C-2J
Alpha 612DJ

Alpha 612E-1J
Alpha 612E-2J

Alpha 612 button
reference

3. TRANSMITTER OUTLINE

3.1 Transmitter Outline

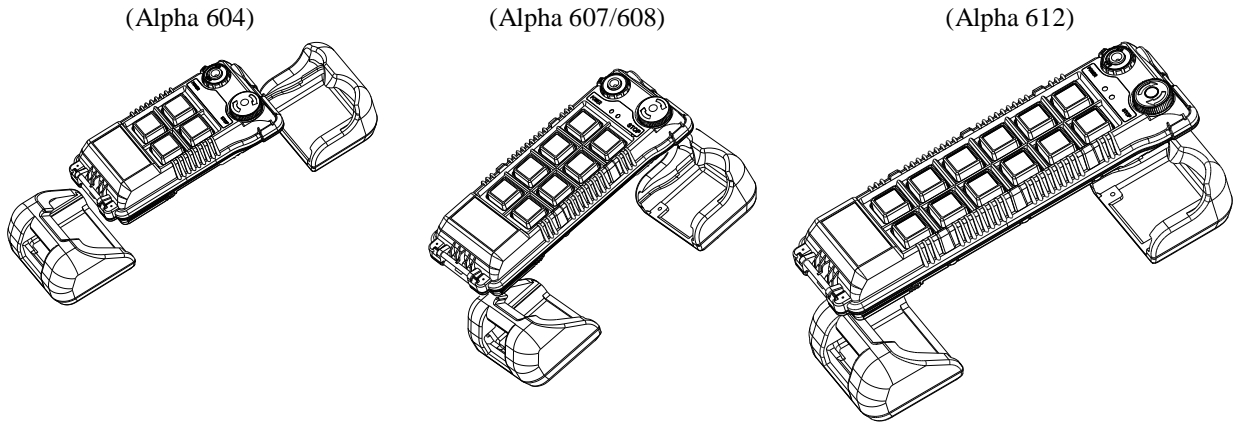

(Fig.1) Transmitter Front View

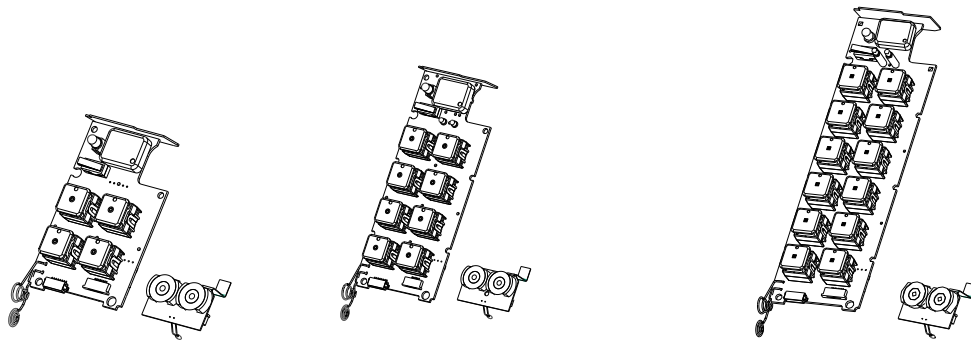

(Fig.2) Transmitter encoder board and induction charging board

(Fig.3) Transmitter Internal Assembly

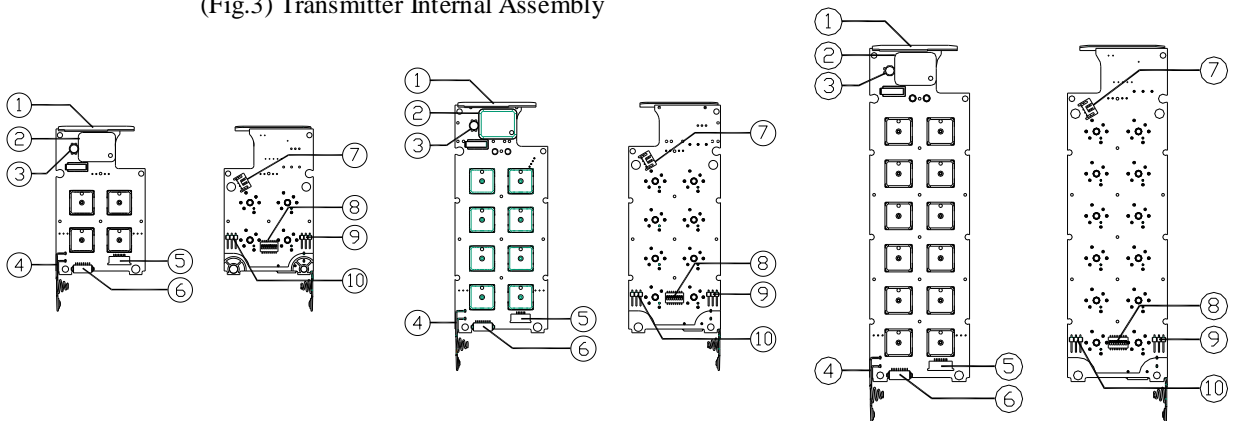

- | | |
|---|----------------------------|
| (1) Internal antenna | (6) Programming port |
| (2) Transmitting RF module | (7) E-stop connecting port |
| (3) Status LED display | (8) Function dip-switch |
| (4) Battery contact | (9) JP2 setting pin |
| (5) Transmitter induction charging port | (10) JP1 setting pin |

3.2 Alpha 604/607/608/612 Spare Parts

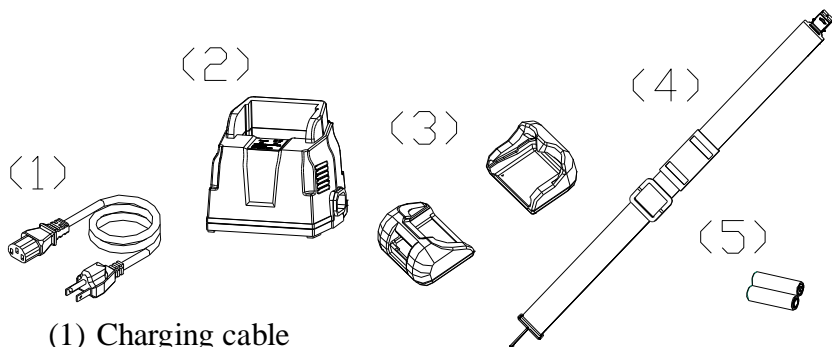

- (1) Charging cable
- (2) Charger (charging cable included, *optional*)
- (3) Transmitter shock-absorbing rubber
- (4) Shoulder strap
- (5) Rechargeable batteries (*optional*)

3.3 Charger Assembly

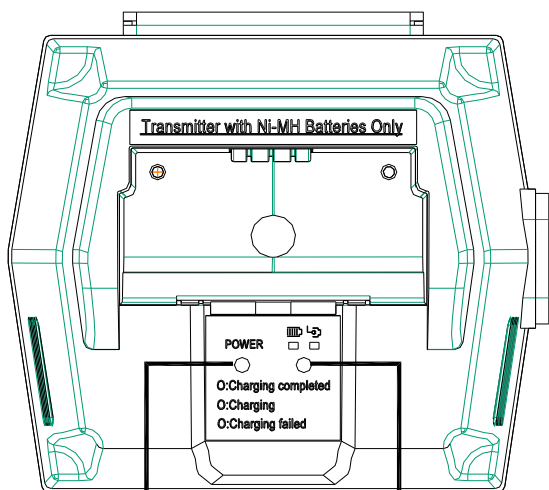

- (1) ① ② Charger power green light
- (2) Charging status: green/red light
- (3-1) Power input socket AC100-240V
- (3-2) Power input socket DC12-24V
- (4) Charger holder (*optional*). Please refer to below figure for the installation holes.

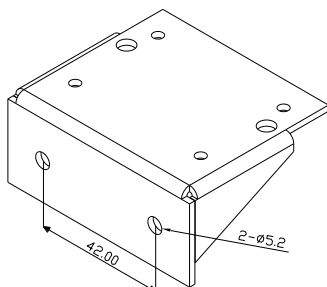
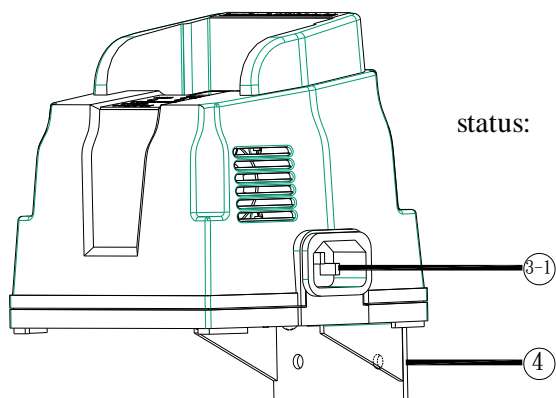
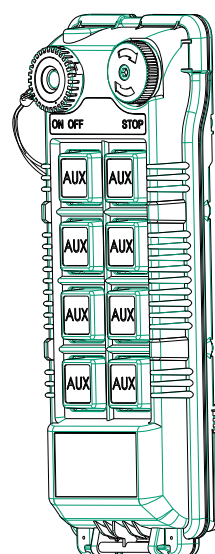

(Fig.4) Battery Charger & Holder

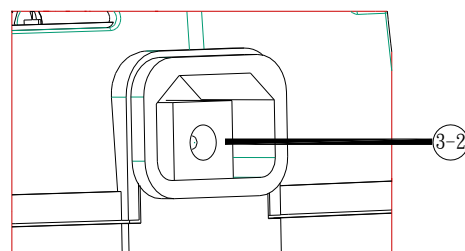

4. RECEIVER OUTLINE

4.1 Alpha 604 ~ 608

4.1.1 Alpha 604 ~ 608 Models External Assembly

SIZE : 310mm X 134mm X 72mm

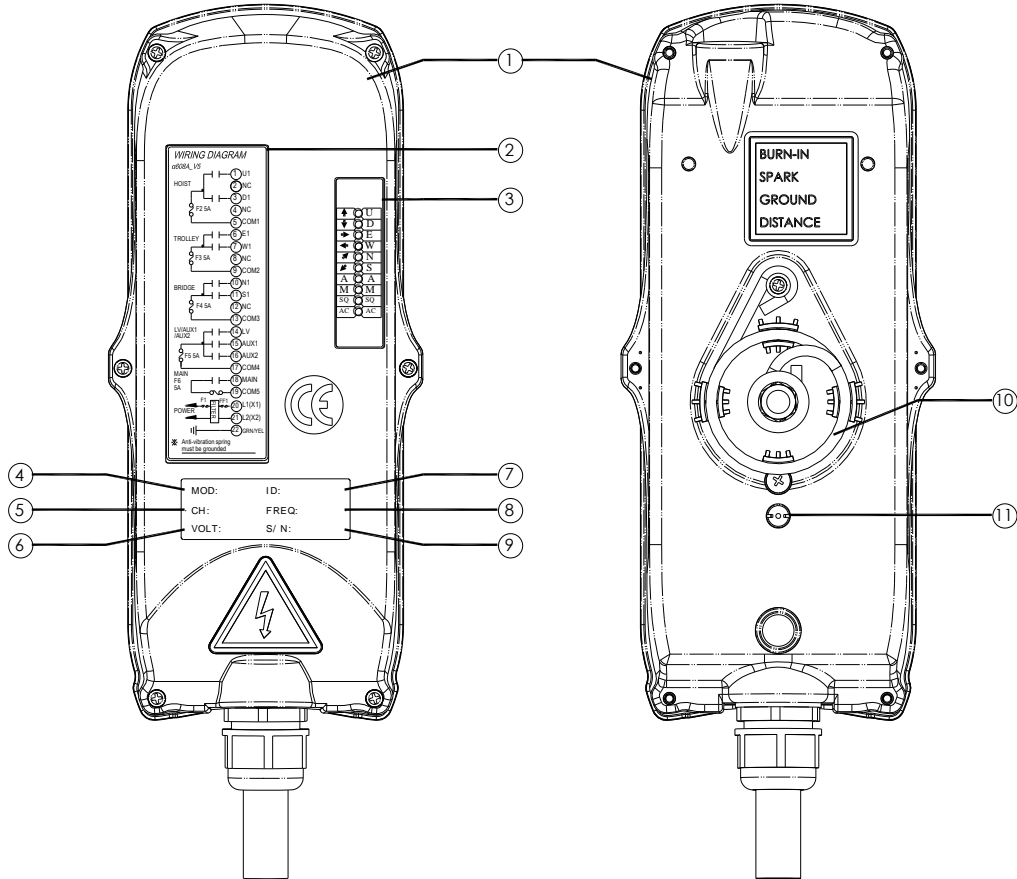

(Fig.5) Front View

(Fig.6) Back View

- | | | |
|---------------------------|----------------------------|---------------------------|
| 1) Receiver enclosure | 5) CH: Group Channel Table | 9) System serial number |
| 2) Wiring diagram | 6) Supplied voltage | 10) Anti-vibration spring |
| 3) Receiver LED displays* | 7) System ID code | 11) Grounding (GND) |
| 4) Type model | 8) Freq: Frequency | |

- * **A** ~ AUX Relay Contact Indicator (for Alpha 607A /608B models only).
- * **M** ~ MAIN and 2nd Speed Relay Contact Indicator.
 Green "on" → MAIN activated (All models).
 Red "on" → 2nd speed activated (for Alpha 608B model only).
- * **SQ** ~ RF Signal Indicator (Red).
 "on" → RF signal detected and received.
 "off" → No RF signal detected or received.
 Blinking at transmitter power "off" → Other radio interference.
- * **AC** ~ Power Source Indicator (red) "on" → AC input power supplied.
 "off" → No AC input power.

4.1.2 Alpha 604 Models Internal Assembly

(Fig. 7) Internal Parts Assembly

- 1) Receiving RF module
- 2) External programming port
- 3) Power module *
- 4) Secondary power AC fuse (F1)
- 5) Primary power AC fuse (FF1)
- 6) Internal Antenna
- 7) System status LED display*
- 8) External antenna port
- 9) ID code dip-switch
- 10) Receiving RF module red status light
- 11) Transmitter binding button
- 12) Contact relay LED display
- 13) Pushbutton #1 and #2 fuse (5.0A)
- 14) MAIN fuse (5.0A)
- 15) Contact output seat (CN3)
- 16) Low-voltage (LV) fuse (5.0A)
- 17) Contact output seat (CN4)
- 18) Pushbutton #3 and #4 fuse (5.0A)
- 19) AC power input seat (CN2)
- 20) Cable gland & output cable
- 21) Spare fuse & jumper compartment
- 22) Spare jumper slots
- 23) Spare fuse slots
- 24) Receiver top casing

* Power module: Including transformer or full-voltage module.

* Please refer to 4.3 α 604/ α 608/ α 612 Receiver Power Fuse List.

*Please refer to page 37 for system status LED display information.

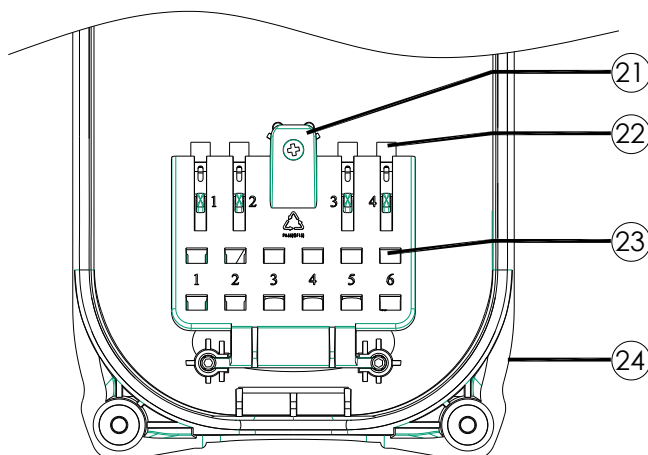
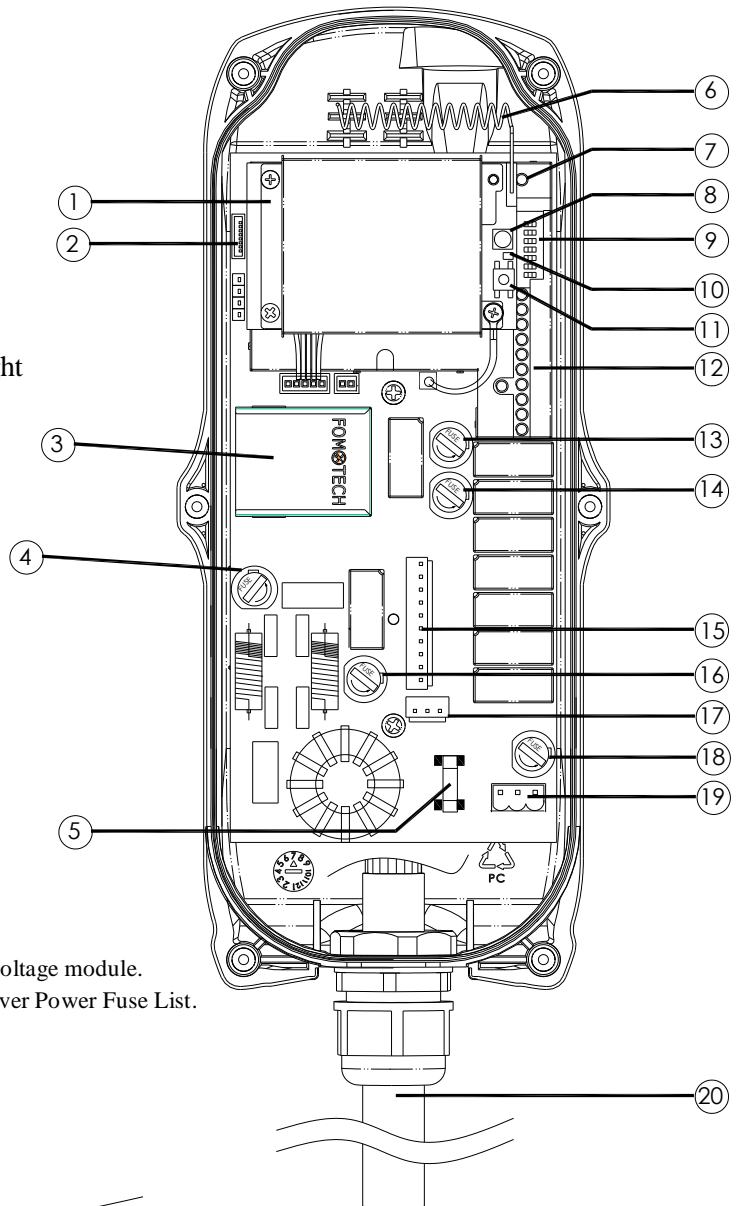

4.1.3 Alpha 607/608 Internal Assembly

(Fig. 8) Internal Parts Assembly

- 1) Receiving RF module
- 2) External programming port
- 3) Power module
- 4) Secondary power AC fuse (F1)
- 5) Contact output seat (CN8)
- 6) Primary power AC fuse (FF1)
- 7) AC power input seat (CN2)
- 8) Internal Antenna
- 9) System Status LED display*
- 10) External antenna port
- 11) ID code dip-switch
- 12) Receiving RF module red status light
- 13) Transmitter binding button
- 14) Contact relay LED display
- 15) Pushbutton #1 and #2 fuse (5.0A)
- 16) Contact output seat (CN3)
- 17) MAIN contact fuse F6 (5.0A)
- 18) Pushbutton #3 and #4 fuse F4 (5.0A)
- 19) Pushbutton #5 and #6 fuse F3 (5.0A)
- 20) Contact output seat (CN4)
- 21) AUX1/AUX2/LV /I/II fuse F5(5.0A)
- 22) Cable gland & output cable

* Power module: Including transformer or full-voltage module.
 * Please refer to 4.3 α 604/ α 608/ α 612 Receiver Power Fuse List.

*Please refer to page 37 for system status LED display information.

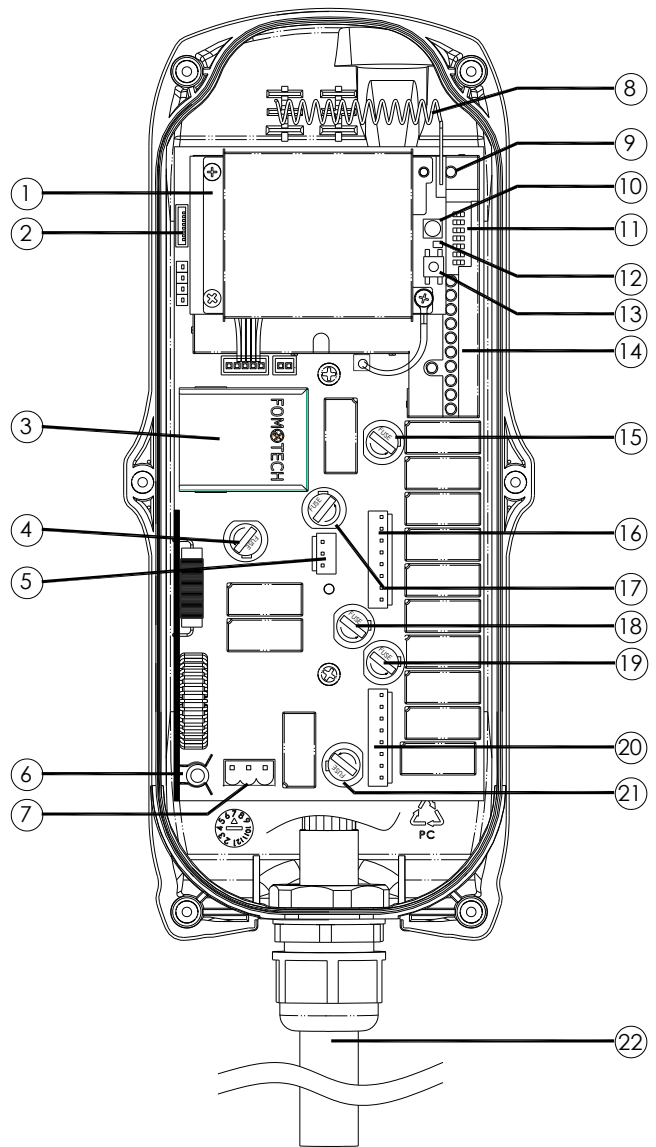

- (1) Spare fuse & jumper compartment
- (2) Spare Jumper slots
- (3) Spare fuse slots
- (4) Receiver top casing

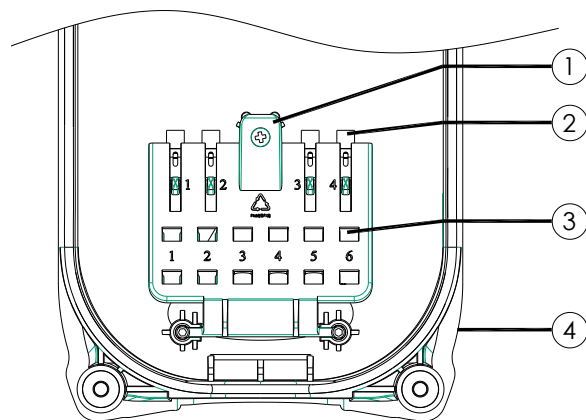

4.2 Alpha 612

4.2.1 Alpha 612 External Assembly

SIZE : 300mm X 230mm X 86mm

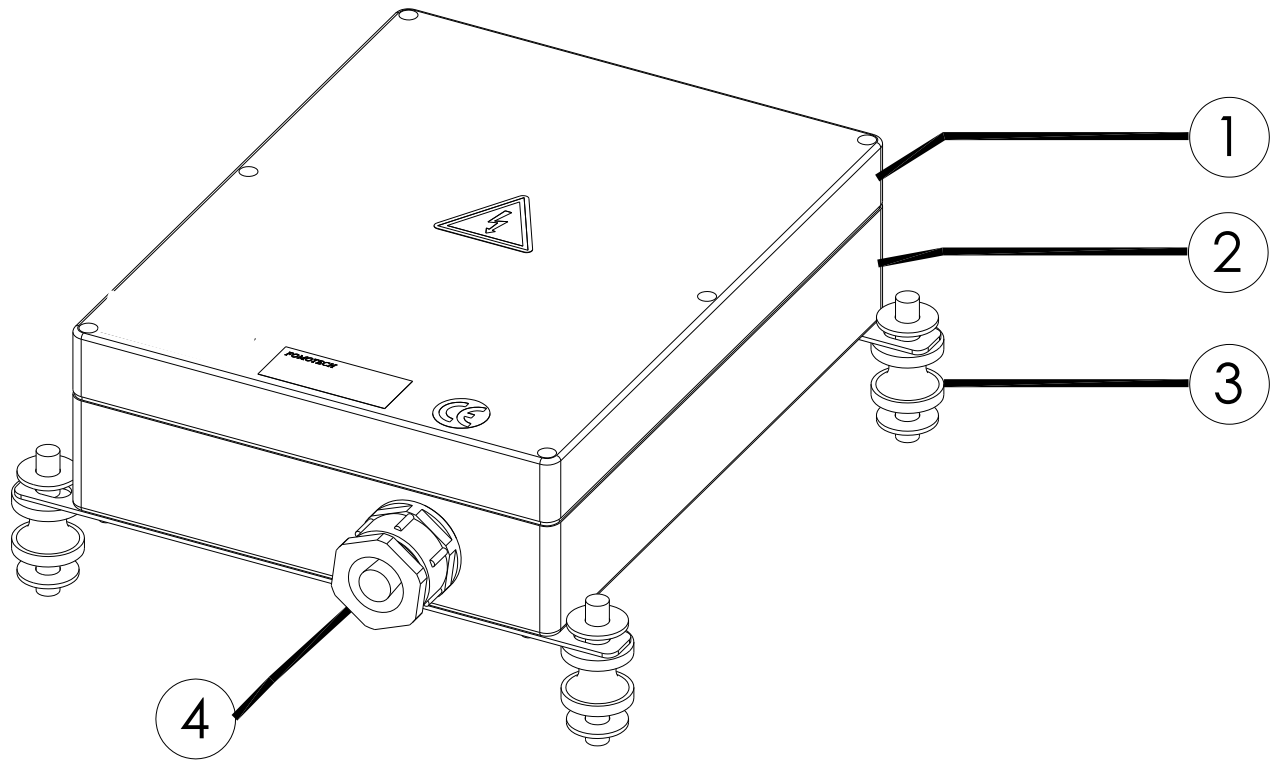

(Fig. 9) External Parts Assembly

- | | |
|----------------------------|--|
| 1) Transparent top cover | 3) Mounting bracket with shock absorbers |
| 2) Light-gray colored base | 4) Cable gland / Cord grip |

4.2.2 Alpha 612 Internal Assembly

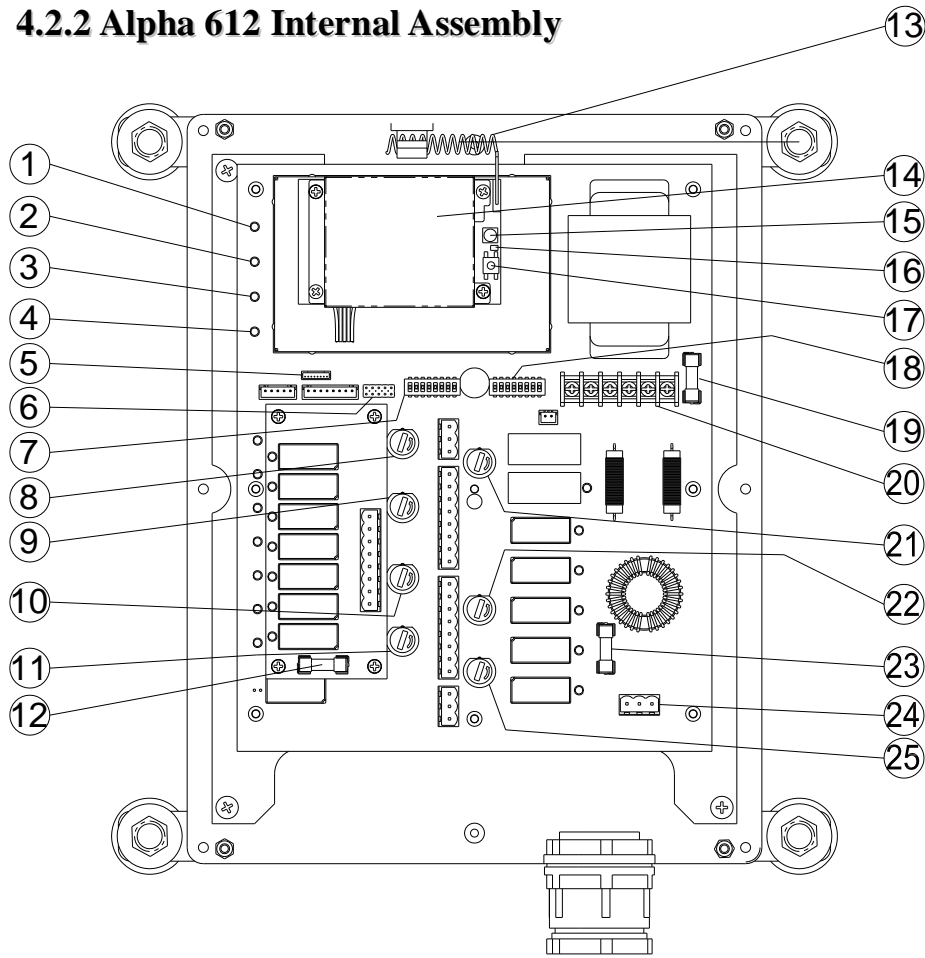

(Fig. 10) Internal Parts Assembly

- | | |
|--|--|
| 1) Power LED display* | 13) Internal Antenna |
| 2) SQ LED display** | 14) Receiving RF module |
| 3) Status LED display**** | 15) External antenna port |
| 4) DC power relay LED display*** | 16) Receiving RF module red status light |
| 5) Programming port | 17) Transmitter binding button |
| 6) Jumper settings | 18) ID code dip-switch |
| 7) Function dip-switch | 19) Secondary power fuse F1*(refer to power fuse list 4.3) |
| 8) Pushbutton #3 and #4 relay fuse (5.0A) | 20) Voltage selector seat |
| 9) Pushbutton #5 and #6 relay fuse (5.0A) | 21) MAIN relay fuse (5.0A) |
| 10) Pushbutton A1 and A2 relay fuse (5.0A) | 22) Pushbutton A4 relay fuse (5.0A) |
| 11) Pushbutton A3 relay fuse (5.0A) | 23) Primary power fuse FF1*(refer to power fuse list 4.3) |
| 12) Pushbutton #1 and #2 relay fuse (5.0A) | 24) Power port CN2 |
| | 25) Low-voltage (LV) relay fuse (5A) |

* **POWER** ~ AC Power Source Indicator "on" → AC input power supplied.

"off" → No AC input power.

** **SQ** ~ RF Signal Indicator "on" → RF signal detected and received.

"off" → No RF signal detected or received.

Blinking at transmitter power "off" → Other radio interference.

*** **RELAY_COM** ~ DC Power Source to Relays "on" → DC power to relays.

"off" → No DC power to relays.

**** **STATUS** ~ Receiver System Status LED Display → Please refer to page 39.

4.3 α 604/ α 608/ α 612 Receiver Power Fuse List

Type	Parts No.	Voltage						
		DC12V~24V	AC24	AC36~48V	AC100~120 V	AC220~240 V	AC380~440 V	AC100~240V Full-Voltage
α 604	FF1	3A			1A		2A	
α 608	F1	3A	2A		0.5A		1A	
α 612	FF1	3A			1A			
	F1	3A	2A		0.8A			

5. OUTPUT CONTACT DIAGRAMS

5.1 Alpha 604 Models

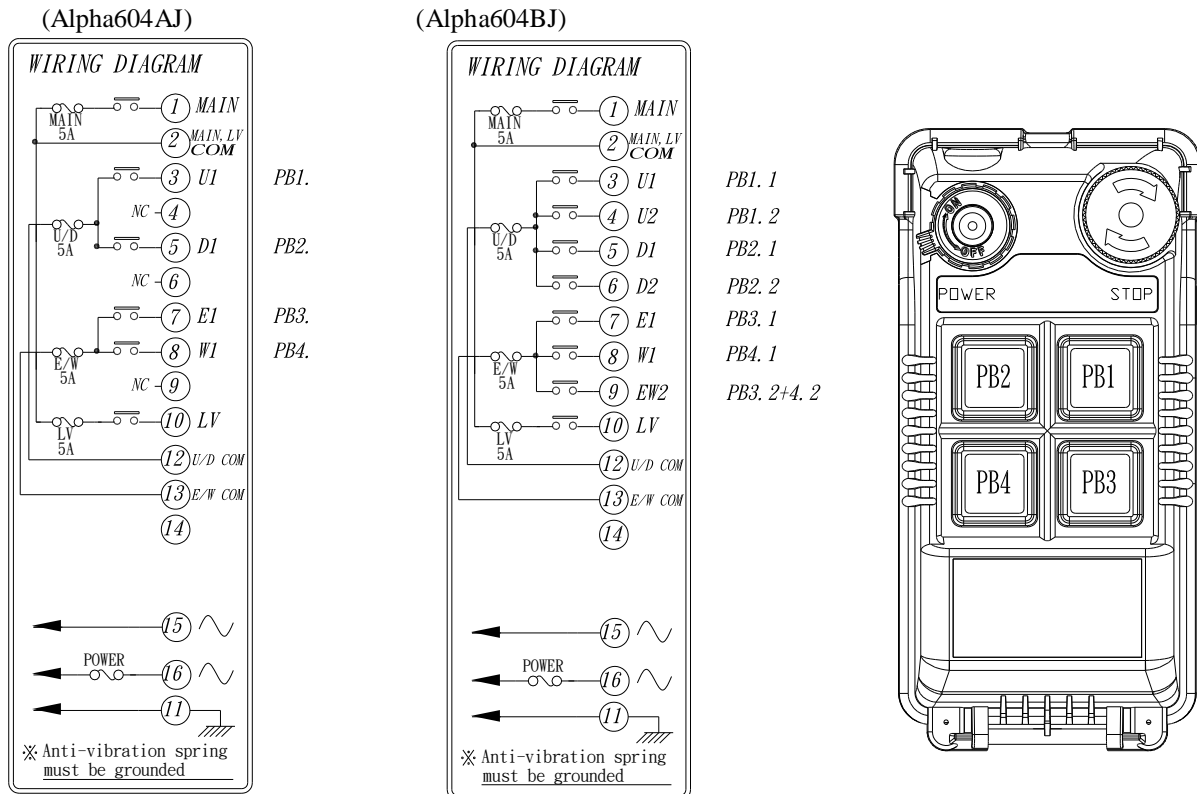

5.2 Alpha 607 Models

(Alpha 607AJ)

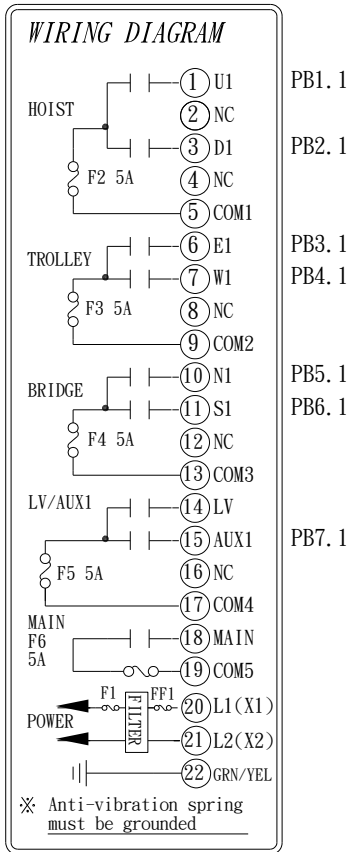

(Alpha 607BJ)

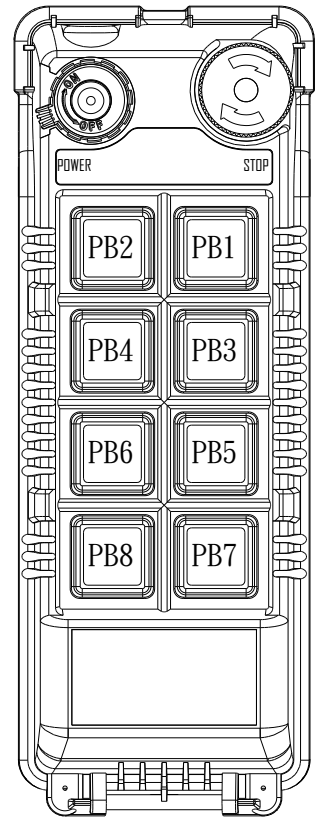
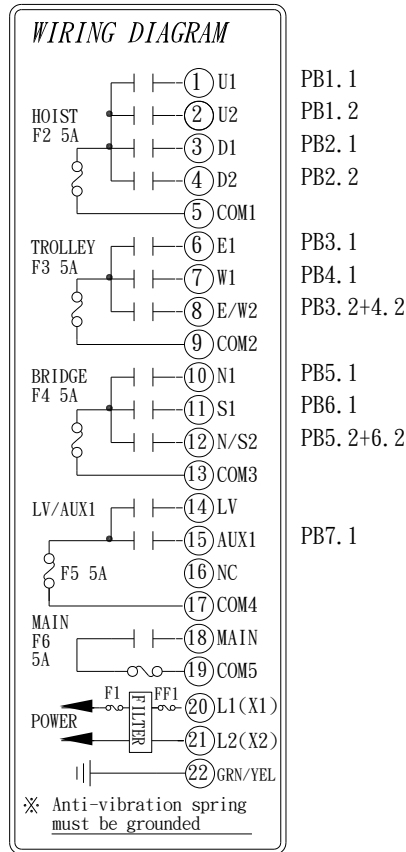

(Alpha 607ATJ)

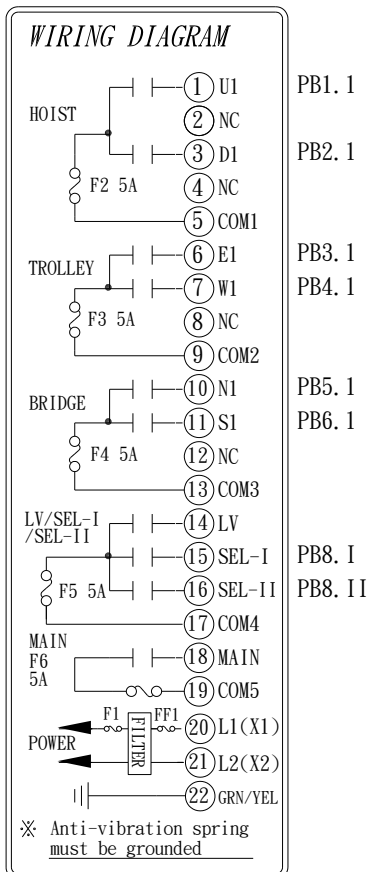

(Alpha 608ATJ)

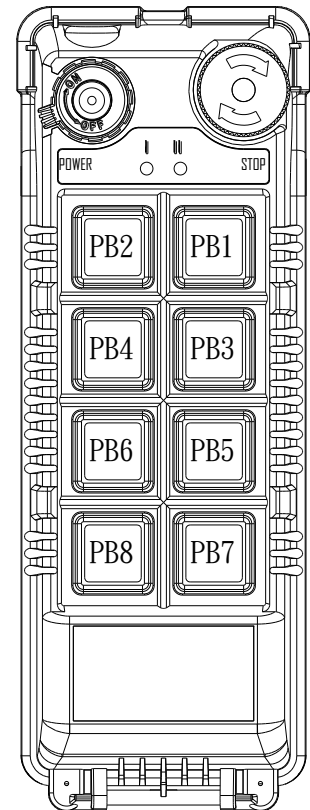
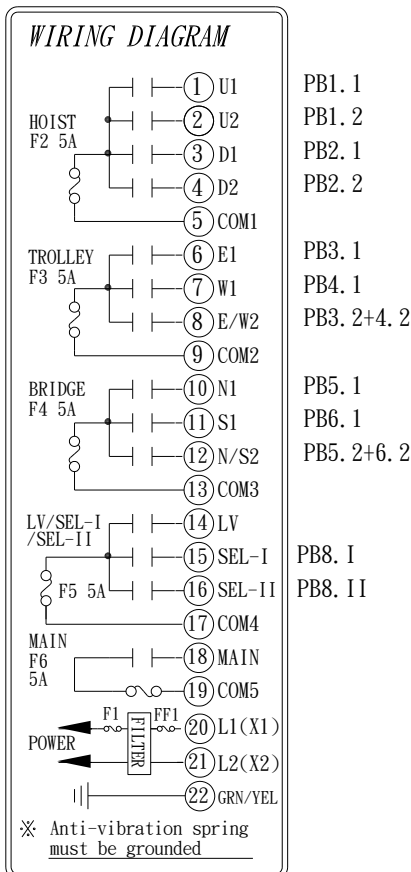

5.3 Alpha 608 Models

(Alpha 608AJ)

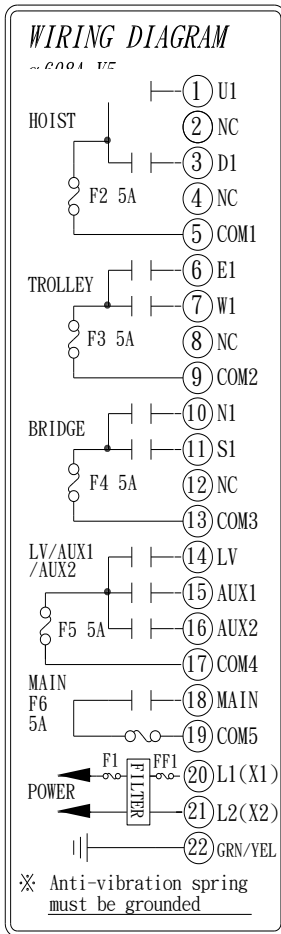

- PB1. 1
- PB2. 1
- PB3. 1
- PB4. 1
- PB5. 1
- PB6. 1
- PB7. 1
- PB8. 2

(Alpha 608BJ)

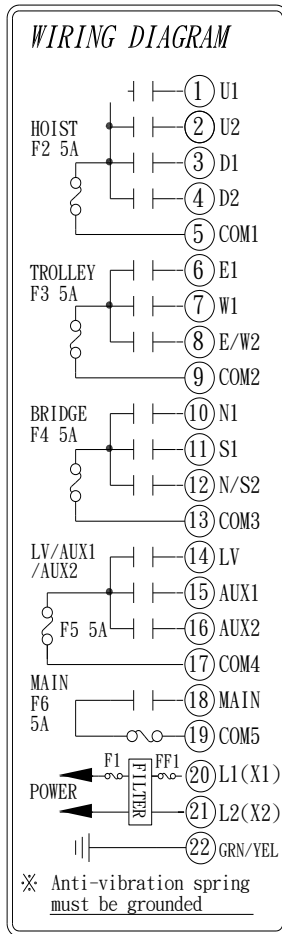

- PB1. 1
- PB1. 2
- PB2. 1
- PB2. 2
- PB3. 1
- PB4. 1
- PB3. 2+4. 2
- PB5. 1
- PB6. 1
- PB5. 2+6. 2
- PB7. 1
- PB8. 2

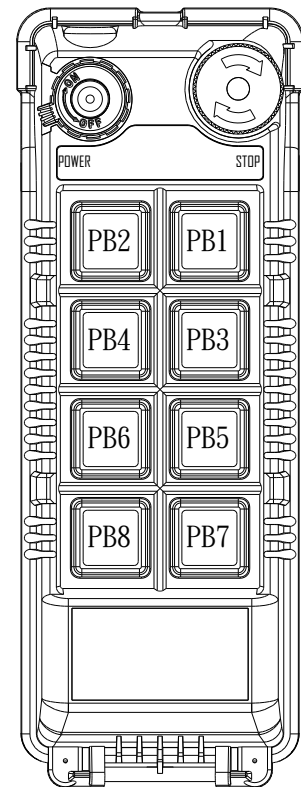

(Alpha 608ATJ)

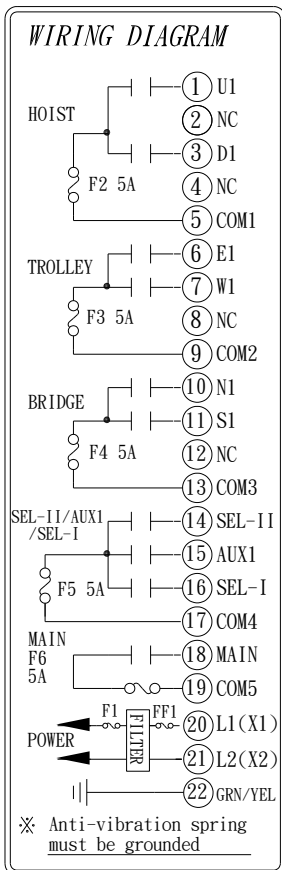

- PB1. 1
- PB2. 1
- PB3. 1
- PB4. 1
- PB5. 1
- PB6. 1
- PB8. II
- PB7. 1
- PB8. I

(Alpha 608BTJ)

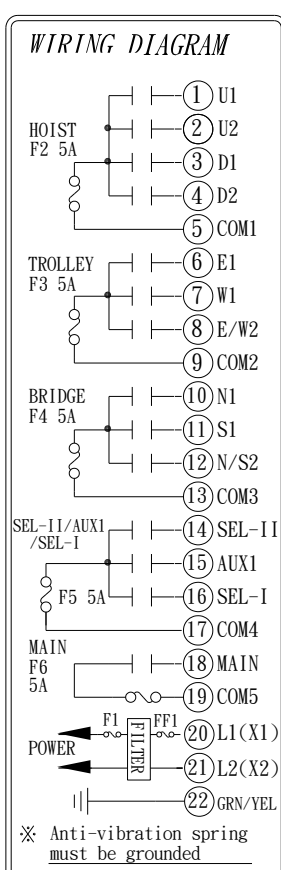

- PB1. 1
- PB1. 2
- PB2. 1
- PB2. 2
- PB3. 1
- PB4. 1
- PB3. 2+4. 2
- PB5. 1
- PB6. 1
- PB5. 2+6. 2
- PB8. II
- PB7. 1
- PB8. I

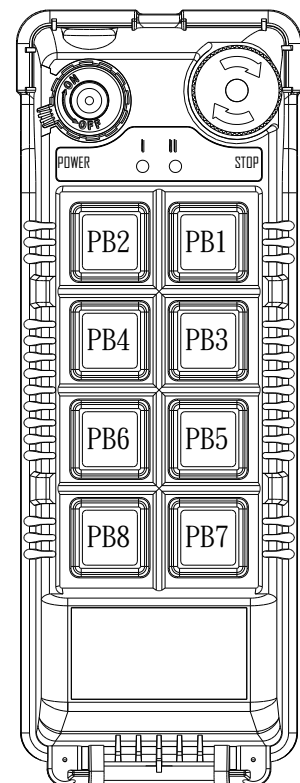

5.4 Alpha 612 Models

(Alpha 612AJ)

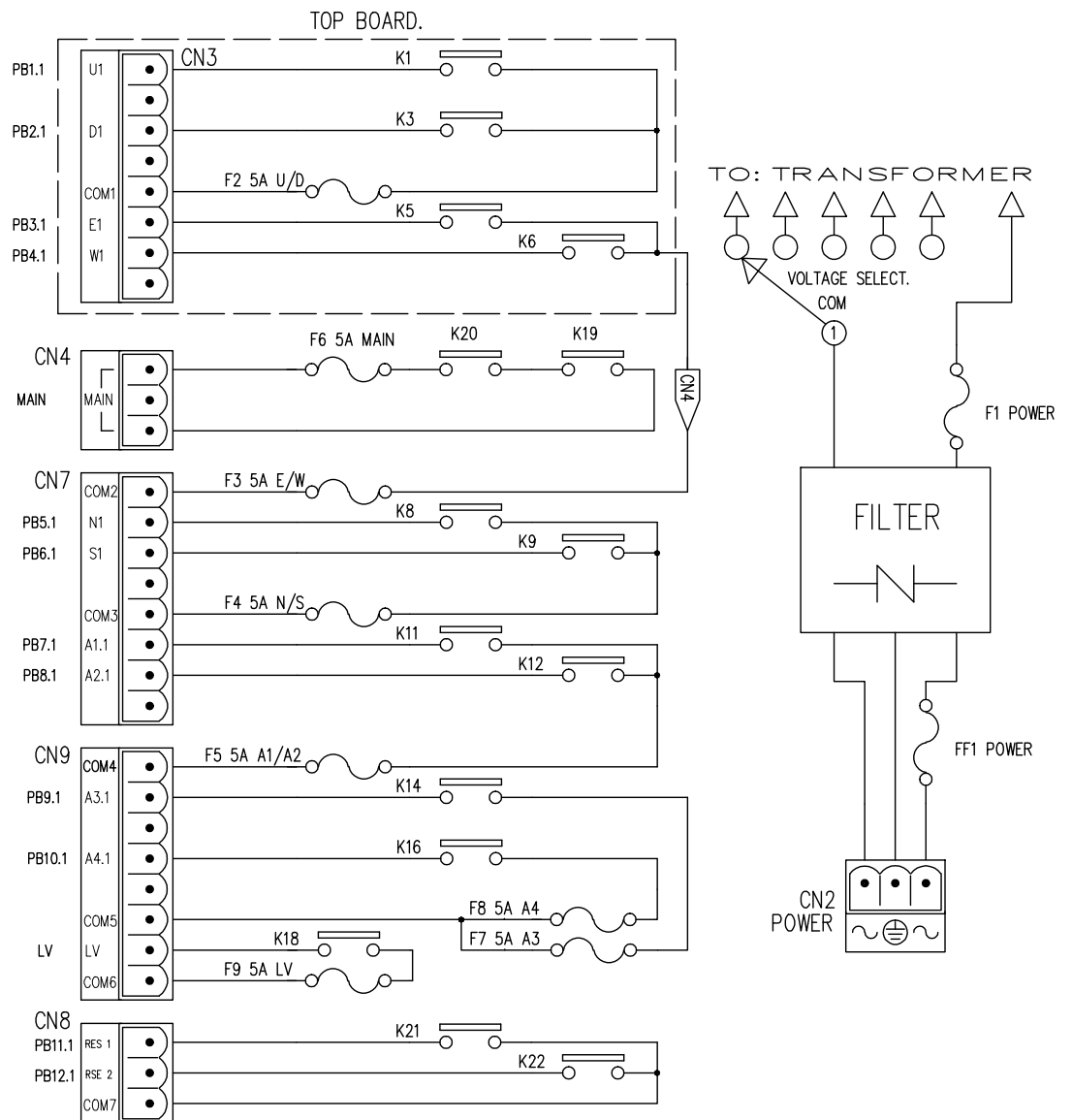
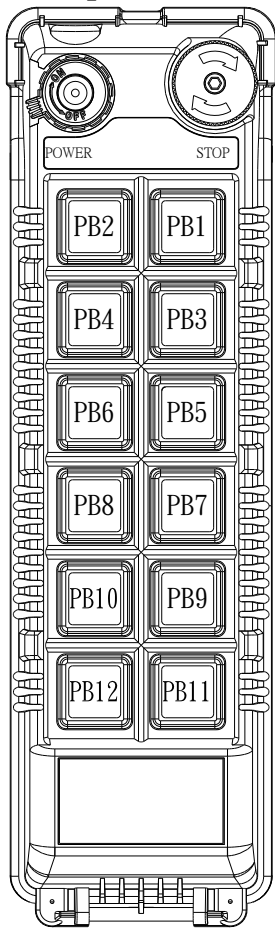

(Alpha 612BJ)

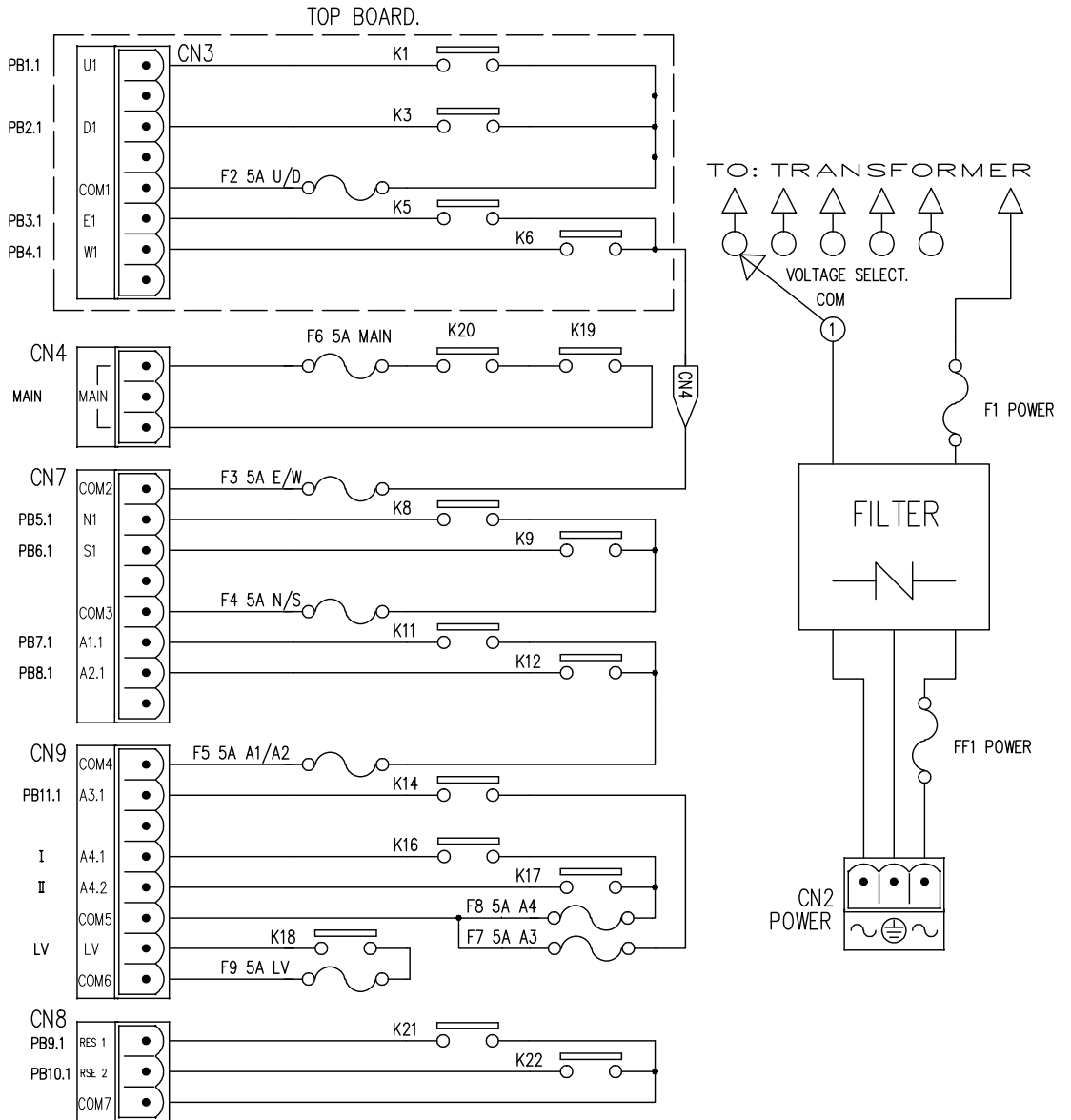
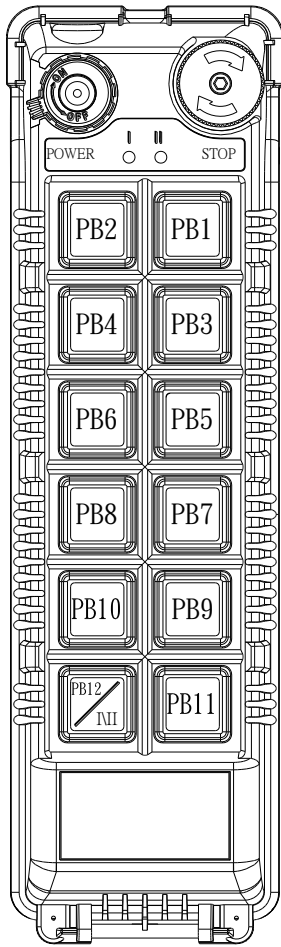

(Alpha 612C-1J)

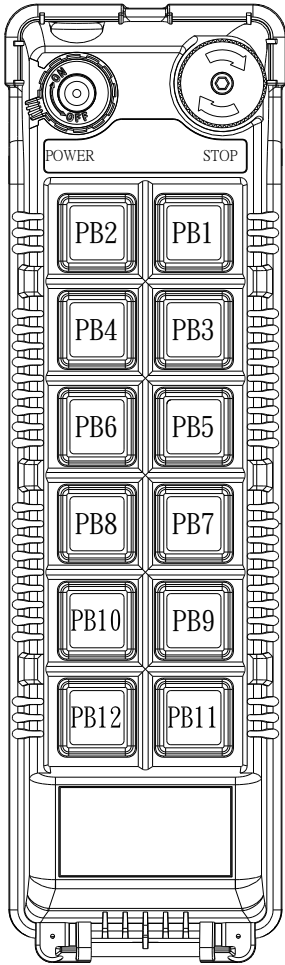

TOP BOARD.

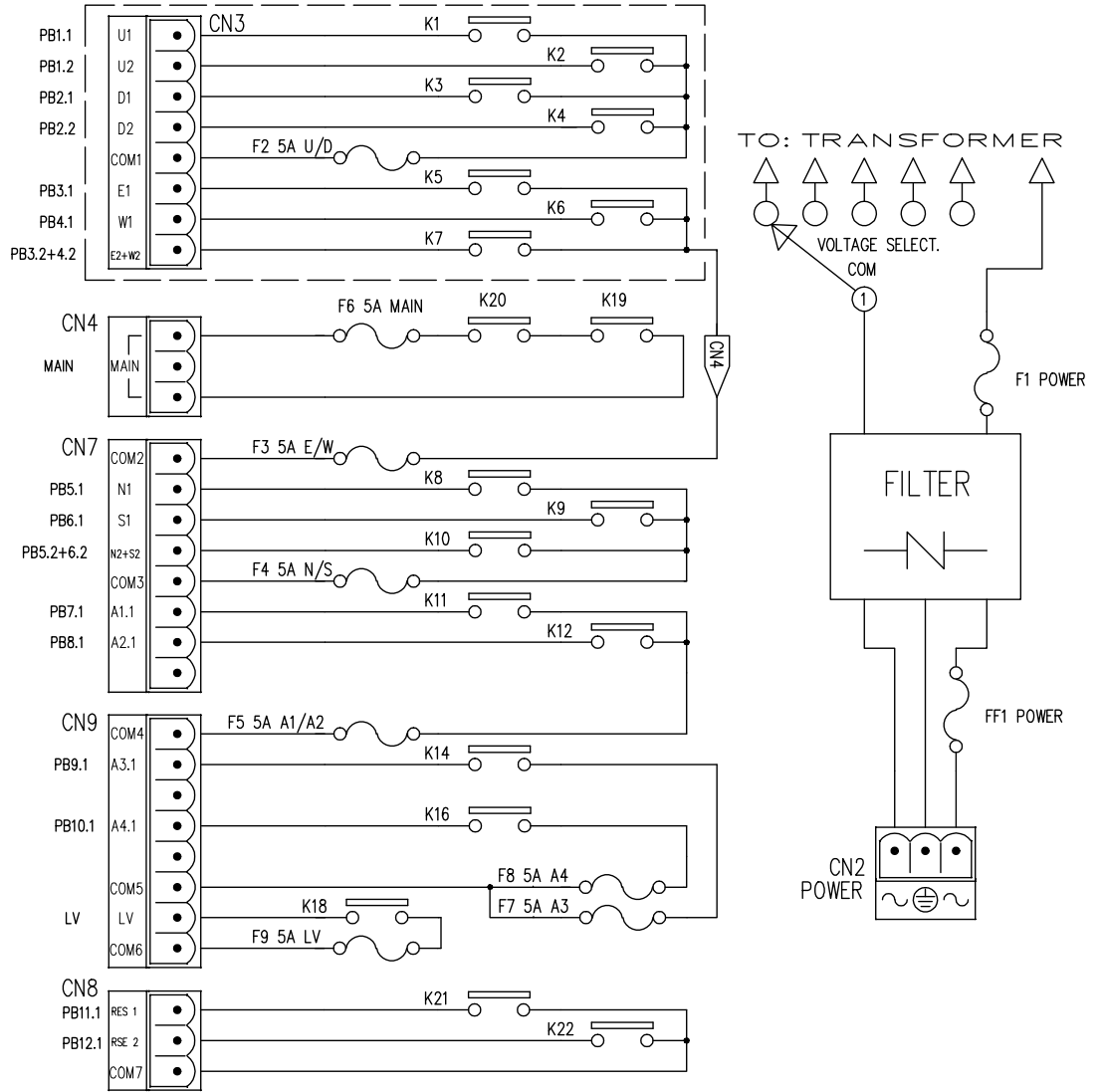

(Alpha612C-2J)

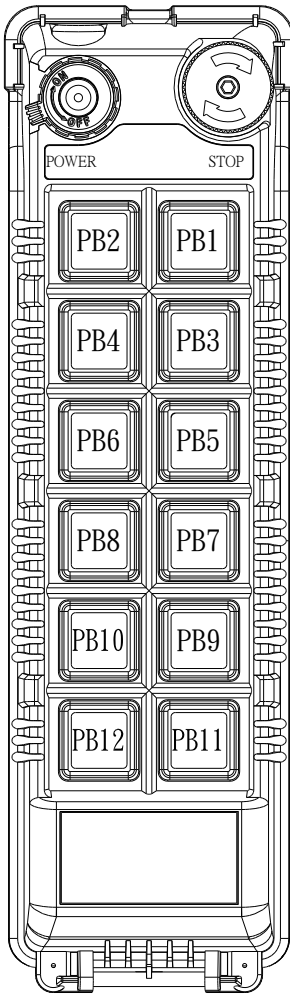

TOP BOARD.

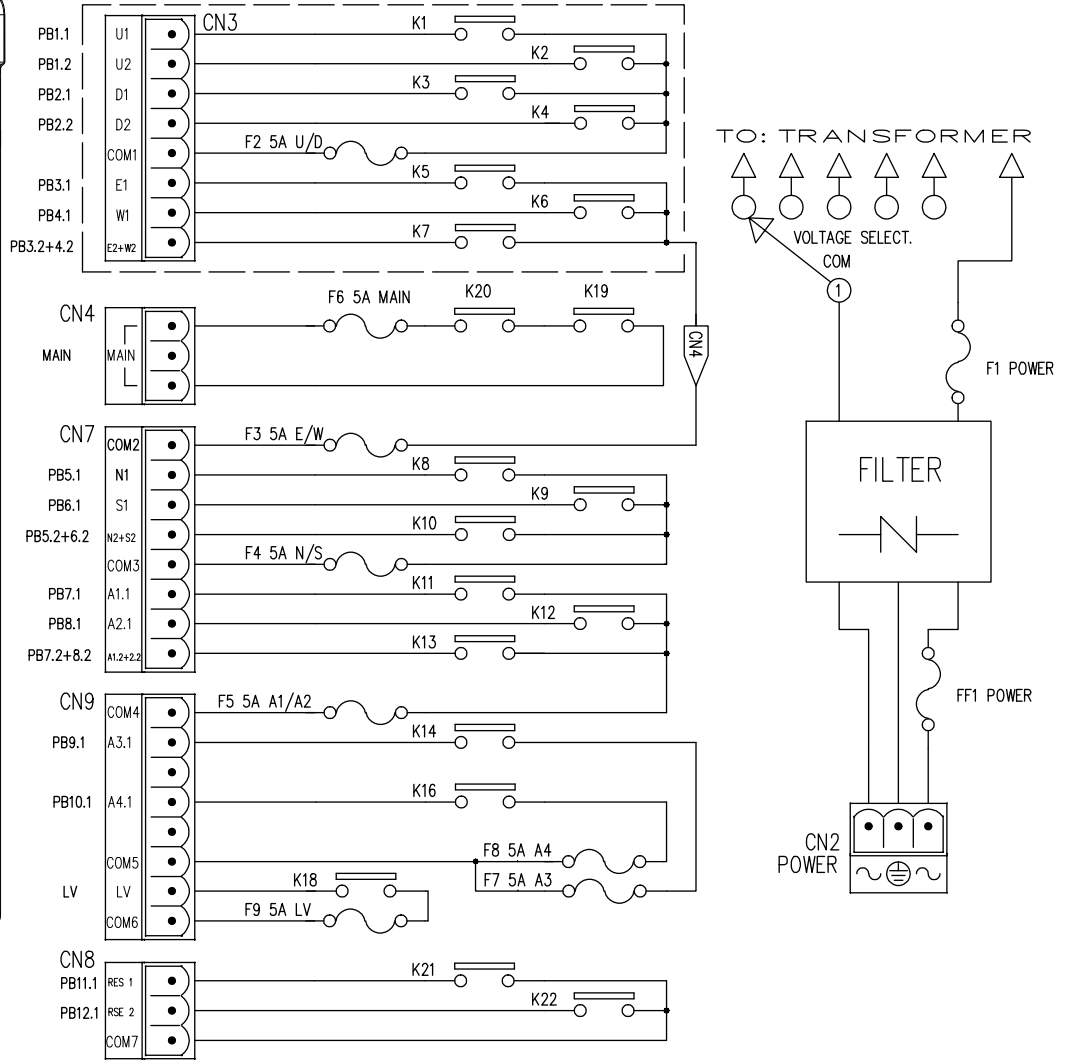

(Alpha 612DJ)

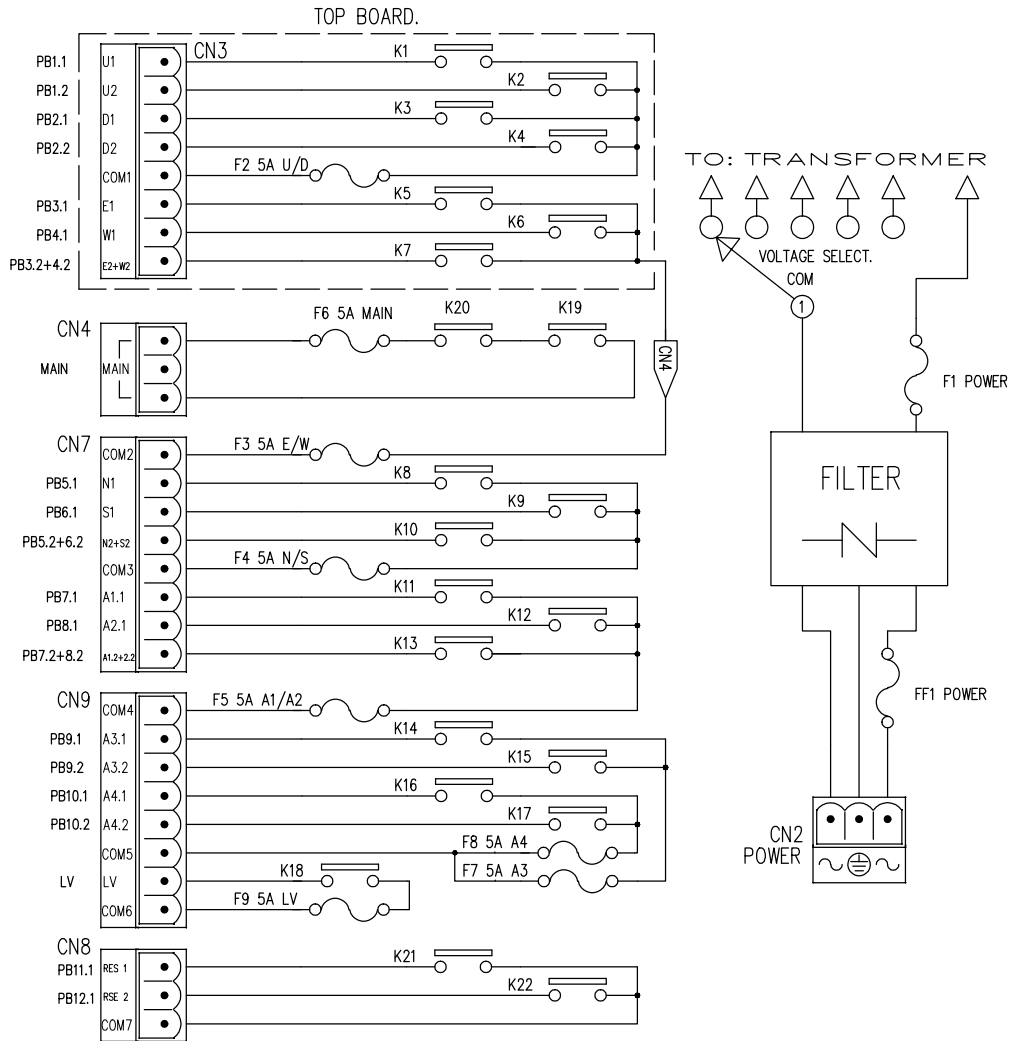
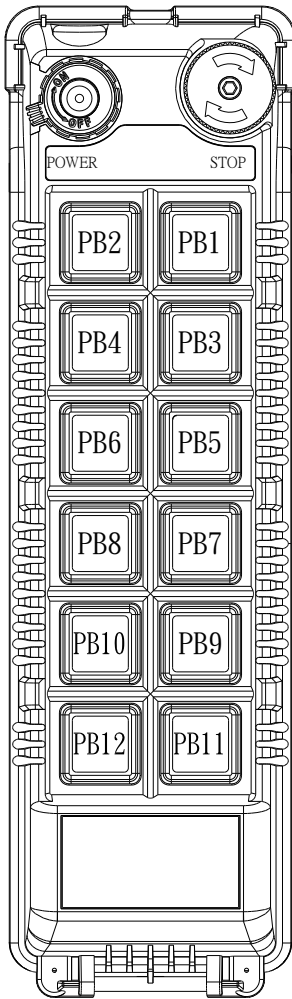

(Alpha 612E-1J)

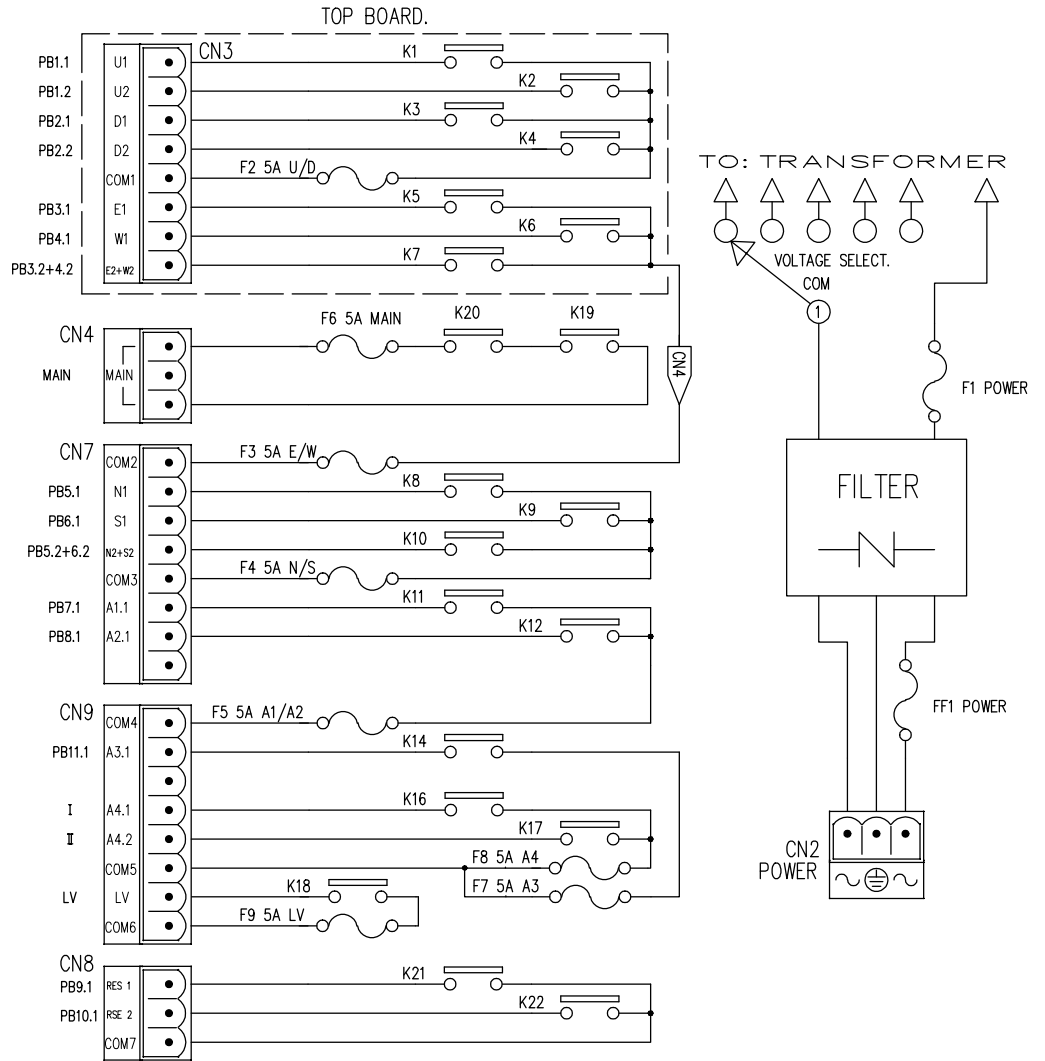
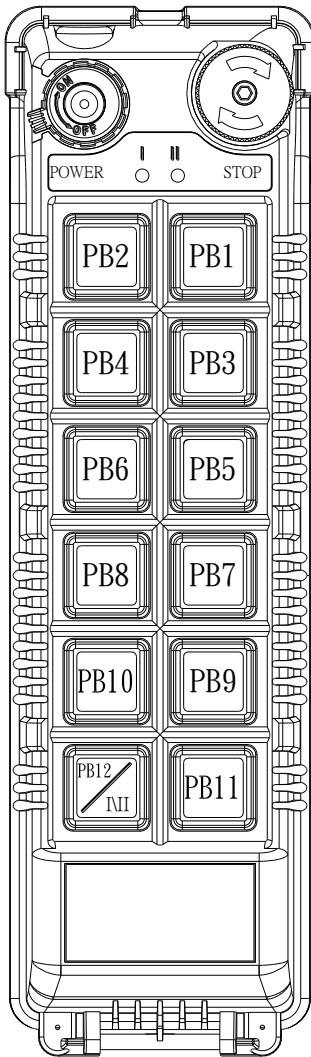

(Alpha 612E-2J)

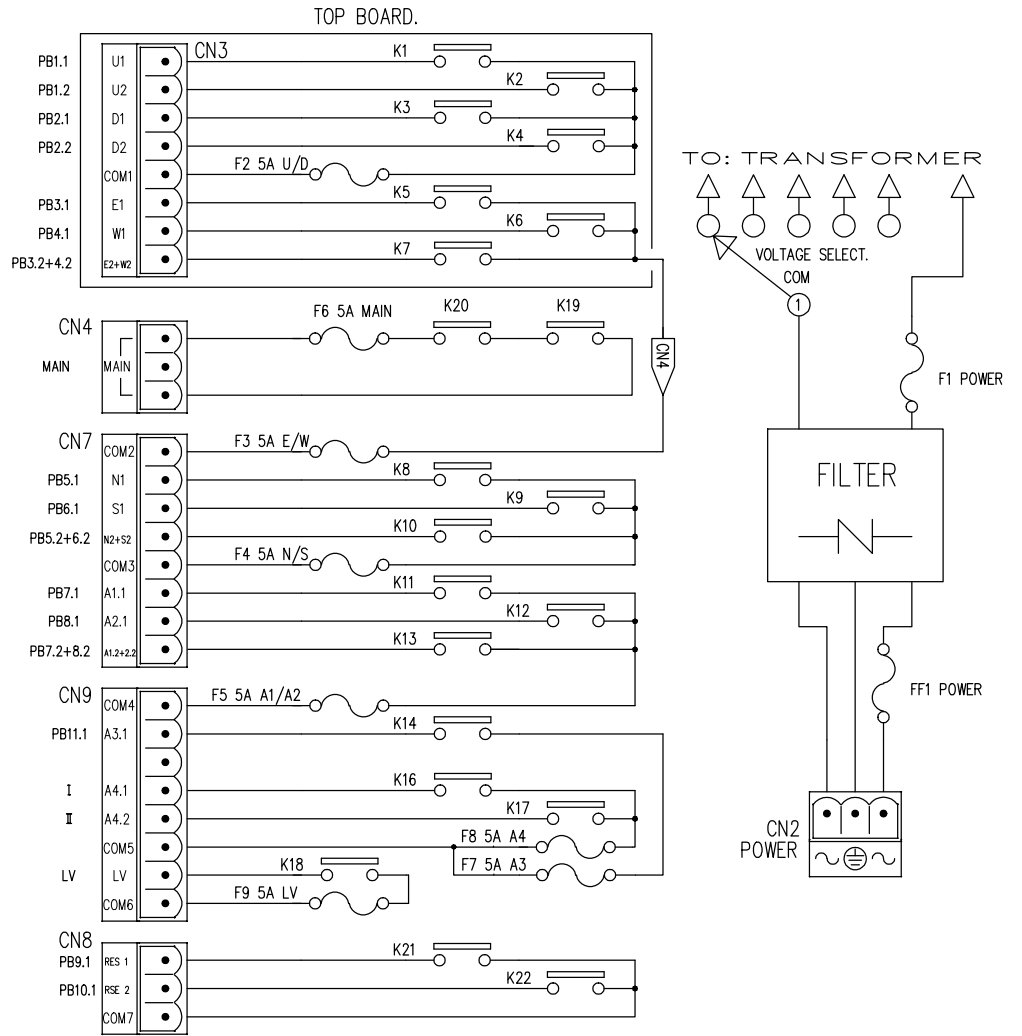
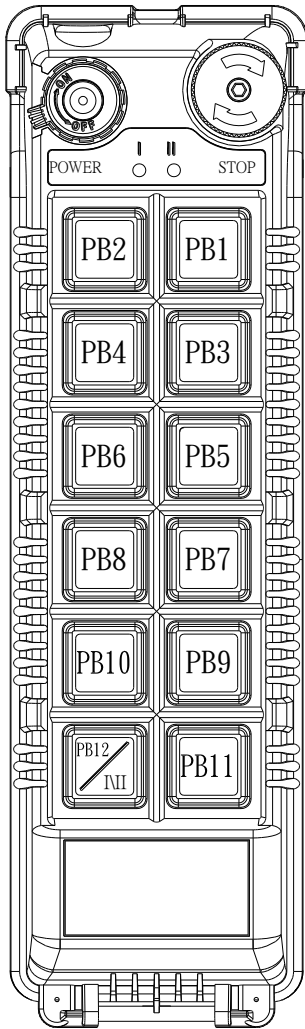

6. SYSTEM CONFIGURATIONS

6.1 How to Set ID Codes

For the Alpha 600XJ series transmitter, except for the spare transmitter, there will have only one default 24 bits ID code. Please do not change it as will to avoid any interference.

If two transmitters set with an identical ID code work for the same receiver, please do not operate two or more transmitters with the same ID code at the same time to avoid danger.

6.1.1 Set by the Alpha 600 programmer.

6.1.2 Set by JP1 and JP2 of encoder board with the dip-switch

The 24 bits of ID code are separated into three sections, for example: if ID code is 12 34 56 (Hexadecimal)

1st section: Example 12 in IDH. Encoder board JP2: 1-2-3 pin first shorted, then set the ID code by the dip-switch.

2nd section: Example 34 in IDM. Encoder board JP2: 2-3 pin first shorted, then set the ID code by the dip-switch.

3rd section: Example 56 in IDL. Encoder board JP1: 1-2 pin first shorted, then set the ID code by the dip-switch.

IDL Setting Steps: (When proceeding with the IDH & IDM setting, be sure to match the corresponding jumper and PIN)

- (1) Rotate the transmitter power switch to OFF position.
- (2) Remove the transmitter shock-absorbing rubber.
- (3) Place the transmitter pushbutton side downward and unscrew the transmitter bottom casing.
- (4) Set the transmitter ID code with the dip-switch on the encoder board and put jumper on the 1st and 2nd pin of JP1.
- (5) Make sure the batteries are installed properly.
- (6) Rotate the transmitter power switch to ON position.
- (7) Green status LED ON for 0.1 sec, OFF for 0.1 sec, flash for 1 sec. (5 times)
- (8) Green status LED steady ON indicates the setting is completed. If the LED status light is changed to red, the setting is failed. Please repeat the above setting steps until the setting is successful.
- (9) After setting is completed and successful, remove the jumper from the 1st and 2nd pin of JP1.
- (10) Rotate transmitter power switch to OFF position.

Encoder board

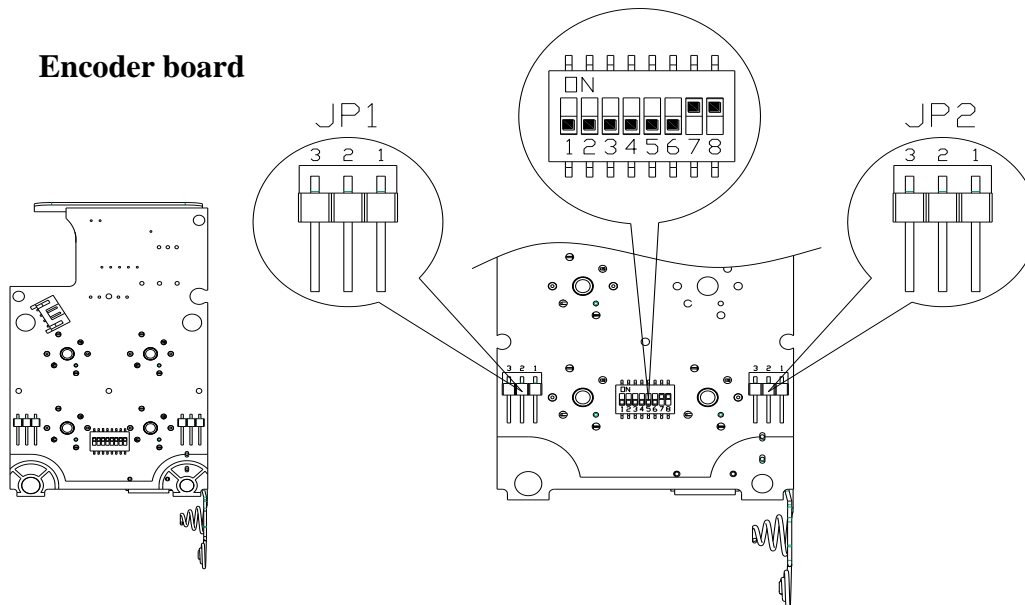

Top slot ON → “1”; bottom slot → “0”. The setting above is 00000011.

6.2 Transmitter Group Channel Settings: Group channel and fixed channel mode

6.2.1 Group Channel Mode

The group channel table is the table for frequency sequence changes. The transmitter channel change is set base on this table. Same as channels from fixing channel selection, be sure to avoid using the same group channel if two of the Alpha 604, 607, 608 or 612XJ transmitters are operated within 300 meters of range.

There are 64 group channels available and two options selectable for group channels:

Auto-cycled group channel _ Whenever any transmitter is power on, the group channel would change in cycle automatically. For example: If same company with more than 64 trucks and each truck with a remote control installed, remote control 1~64 will be using assigned group channel. The 65th remote control and after may select auto-cycled group channel. When many remote controls are operated in the same working environment, in case any transmitter with auto-cycled group channel is interfered with other transmitters, please power off the transmitter and power on again to change group channel.

Assigned group channel _ Use only one of the 64 group channels at one time. If more than two Alpha 600 group channel mode transmitters are operated in the same working environment at the same time, each transmitter is set with different assigned group channel to avoid interference.

When more than two transmitters are operated in the same working environment at the same time, interference may occur for several seconds when the same group channel is using for minutes or hours. The MAIN relay will be unlatched when the receiver is not receiving any signals from the transmitter. (When the transmitter group channel is changed, the receiving RF module will receive the new channel automatically without setting changes.)

6.2.2 Group Channel Settings:

- 1) Set by the Alpha 600 programmer.
- 2) Set by the encoder board 2nd & 3rd pin of JP1 and dip-switch.

Auto-cycled group channel: JP1 2, 3 short + dip-switch set as 00000000

Assigned group channel: JP1 2, 3 short + dip-switch set by following below table.

Group Channel	Dip-Switch Setting	Group Channel	Dip-Switch Setting	Group Channel	Dip-Switch Setting	Group Channel	Dip-Switch Setting	Group Channel	Dip-Switch Setting
1	00000001	14	00001110	27	00011011	40	00101000	53	00110101
2	00000010	15	00001111	28	00011100	41	00101001	54	00110110
3	00000011	16	00010000	29	00011101	42	00101010	55	00110111
4	00000100	17	00010001	30	00011110	43	00101011	56	00111000
5	00000101	18	00010010	31	00011111	44	00101100	57	00111001
6	00000110	19	00010011	32	00100000	45	00101101	58	00111010
7	00000111	20	00010100	33	00100001	46	00101110	59	00111011
8	00001000	21	00010101	34	00100010	47	00101111	60	00111100
9	00001001	22	00010110	35	00100011	48	00110000	61	00111101
10	00001010	23	00010111	36	00100100	49	00110001	62	00111110
11	00001011	24	00011000	37	00100101	50	00110010	63	00111111
12	00001100	25	00011001	38	00100110	51	00110011	64	01000000
13	00001101	26	00011010	39	00100111	52	00110100		

6.2.3 Fixed Channel Mode:

It is for sending signals with fixed frequency. (Whenever there is any area covered by some interference within frequency 902~928MHz and the remote control operation is not smooth under group channel mode, fixed channel mode can be used instead. The fixed channel mode is good for some area tested without frequency interference and the non-interfered fixed channel may be used.)

- * For Alpha 604, 607, 608 or 612XJ transmitter, please avoid using the same channel for interference concern.
- * To change from group channel mode to fixed channel mode, only transmitter needs to be converted and the receiver settings remain unchanged. When the transmitter mode is converted from group channel to fixed channel, it takes 1~40 seconds for the receiver to search for the transmitter with identical setting after it is first power on. After the receiver catches the transmitter, the transmitter may operate the receiver whenever it is power on.
- * To avoid the receiver in use from being interfered by the transmitter with adjacent channel, please keep

distance for more than 2 meters to the transmitter with adjacent channel and the receiver in use. The best way to avoid interference is to keep channel interval over 2 for operating distance within 300 meters.

* To operate transmitters with group channel and fixed channel within 300 meters of range, please use different group channels for transmitter under group channel mode. For transmitter with fixed channel mode, please use different channels and keep channel interval over 2. Please also keep total quantity of operating transmitters within 10 sets.

6.2.4 Fixed Channel Mode Settings:

- 1) Set by the Alpha 600 programmer.
- 2) Set by the encoder board 2nd & 3rd pin of JP1 and dip-switch.

Assigned channel: JP1 2, 3 short + dip-switch set by following below table.

Fixed channel mode: Channel/dip-switch setting/frequency table.

Channel	Dip-switch	Freq. MHz	Channel	Dip-switch	Freq. MHz	Channel	Dip-switch	Freq. MHz	Channel	Dip-switch	Freq. MHz
1	10000001	903.0	14	1000111	909.5	27	1001101	916.0	40	10101000	922.5
2	10000010	903.5	15	1000111	910.0	28	1001110	916.5	41	10101001	923.0
3	10000011	904.0	16	1001000	910.5	29	1001110	917.0	42	10101010	923.5
4	10000100	904.5	17	1001000	911.0	30	1001111	917.5	43	10101011	924.0
5	10000101	905.0	18	1001001	911.5	31	1001111	918.0	44	10101100	924.5
6	10000110	905.5	19	1001001	912.0	32	1010000	918.5	45	10101101	925.0
7	10000111	906.0	20	1001010	912.5	33	1010000	919.0	46	10101110	925.5
8	10001000	906.5	21	1001010	913.0	34	1010001	919.5	47	10101111	926.0
9	10001001	907.0	22	1001011	913.5	35	1010001	920.0	48	10110000	926.5
10	10001010	907.5	23	1001011	914.0	36	1010010	920.5	49	10110001	927.0
11	10001011	908.0	24	1001100	914.5	37	1010010	921.0	50	10110010	927.5
12	10001100	908.5	25	1001100	915.0	38	1010011	921.5			
13	10001101	909.0	26	1001101	915.5	39	1010011	922.0			

6.3 Transmitter group channel /channel display

How to check the transmitter is under group channel or fixed channel mode:

1. Rotate the power switch to off position and then rotate the emergency stop button clockwise to pop it up.
2. Press Up and Down buttons at the same time without releasing. Then rotate the power switch to ON position and release the Up and Down buttons.

3. The LED status within 1st second when the power is On:

Red LED On: Channel group mode

Green LED On: Fixed channel mode

4. After the 1st second display of group channel or fixed channel mode, the status LED will be off and then display group channel or fixed channel number repeatedly, as described below:

Status LED: Red LED blink once +10, Green LED blink once +1. The blink will be continued repeatedly until the transmitter power switch is off.

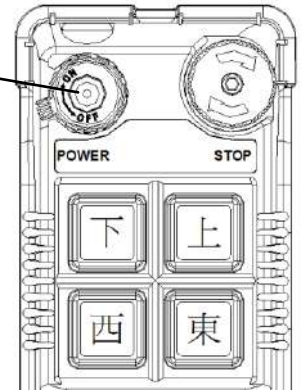

Example 1: The 1st second will be after the green LED is On. Red LED blink once, no green LED blink repeatedly. It is channel 10 under the fixed channel mode.

Example 2: The 1st second will be after the green LED is On. No red LED blink, green LED blink once repeatedly. It is channel 01 under the fixed channel mode.

Example 3: The 1st second will be after the green LED is On. Red LED blink 3 times, green LED blink 9 times repeatedly. It is channel 39 under the fixed channel mode.

Example 4: The 1st second will be after the red LED is On. Red LED blink 5 times, green LED blink 7 times repeatedly. Rotate the transmitter to off position and try again with the same result. It is group channel 57 under the assigned group channel mode.

Example 5: The 1st second will be after the red LED is On. Red LED blink 2 times, green LED blink 5 times repeatedly. Rotate the transmitter to off position and try again with the same result. It is group channel 57 under the auto-cycled group channel mode.

When the 1st second display is red LED On group channel mode, after matching the group channel table with the LED status displayed, power off the transmitter and repeat the display again. If the same channel group displayed for two times, it would be fixed channel group mode (example 4), if not, it will be Auto-cycled group channel (example 5).

Under the display of group channel table or channel number status, press WEST button to enter transmitter binding mode. Please see 7.3 for details.

Under the display of group channel table or channel number status:

Group channel mode: The transmitter will send 902.0MHz carrier wave continuously for testing.

Fixed channel mode: The transmitter will send the carrier wave of its frequency continuously for testing.

7. RECEIVER SETTINGS

7.1 How to set α 604/607/608 Receiver ID Codes

For the α 600 group channel series, it is no need to change any setting of group ID code (GID), ID code, group channel and receiving channel to the receiver but only to bind the setting of the receiving RF module with the transmitter.

- ※ The default setting of α 604/607/608 receiver ID code is 00000000 which might not be identical to the setting of transmitter IDH/IDM/IDL code. Please keep the default setting of receiver ID code as it is (see below). For the receiver group ID code (GID) which is set by the Alpha 600 software, please keep it as default setting 00 to avoid odd and even number problem on GID+ID.

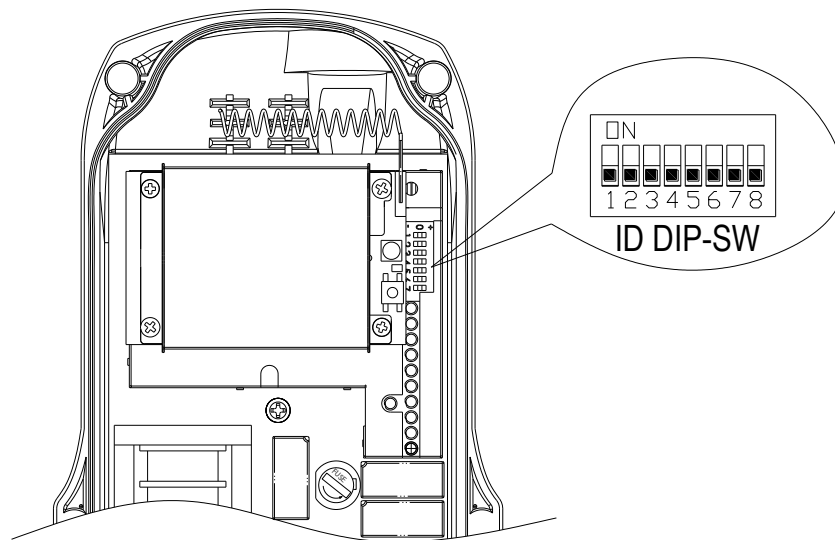

7.2 How to Set α 612 Receiver ID Codes

Please refer to Fig. 10 Internal Parts Assembly (Page 12) for the 8-position ID code dip-switch to set the receiver ID code.

- ※ The default setting of α 612 receiver ID code is 00000000 which might not be identical to the setting of transmitter IDH/IDM/IDL code. Please keep the default setting of the receiver ID code as it is (see below).

Top slot →“1”; **bottom slot →“0”**

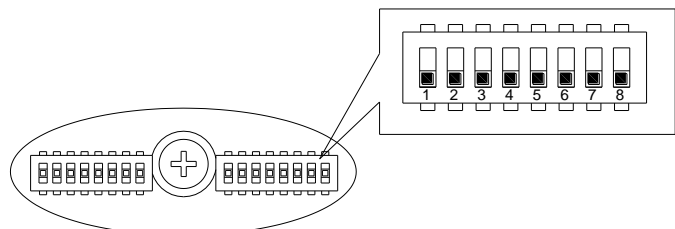

Set the ID codes needed to the decoder board dip-switch. For the receiver group ID code (GID) which is set by the Alpha 600 software, please keep it as default setting 00 to avoid odd and even number problem on GID+ID.

7.3 Receiving RF Module Binding

The Alpha 600XJ series is using the receiving RF module to bind with each transmitter. That is, the receiving RF module memorizes the system type and ID code of the transmitter. The receiving RF module is receiving signals only when the system type and ID code received are identical to the ones saved in the memory. If not, the signals will be objected.

1. One receiving RF module can only bind with one transmitter ID. Whenever a different transmitter with different ID code is replaced, the procedure of receiving RF module binding will need to be started again.
2. If the spare transmitter and the original one are set with the same ID code, the spare transmitter can be operated again without been binding again.
3. The same transmitter can be bound with several receiving RF modules at the same time. That is, the transmitter can work with all the receivers which have ever been bound.

Receiving RF Module LED Status Table

Receiving RF module			
Priority	Red status LED	Binding button	Status instruction
1	Blink twice every second	Not related	TX testing mode (for in-factory testing)
2	Flash (0.1 sec On/0.1 sec Off)	Press & hold	Transmitter pairing successfully
3	Not lit	Press & hold	Not yet bound to any transmitter
4	Not lit	No pressed	No any transmitter binding records
5	Quick flash (0.05 sec On/0.05 sec Off)	No pressed	Receiving signals for transmitter bound
6	Slow flash (1 sec On/1 Sec Off)	No pressed	Transmitter bound, waiting to be operated.

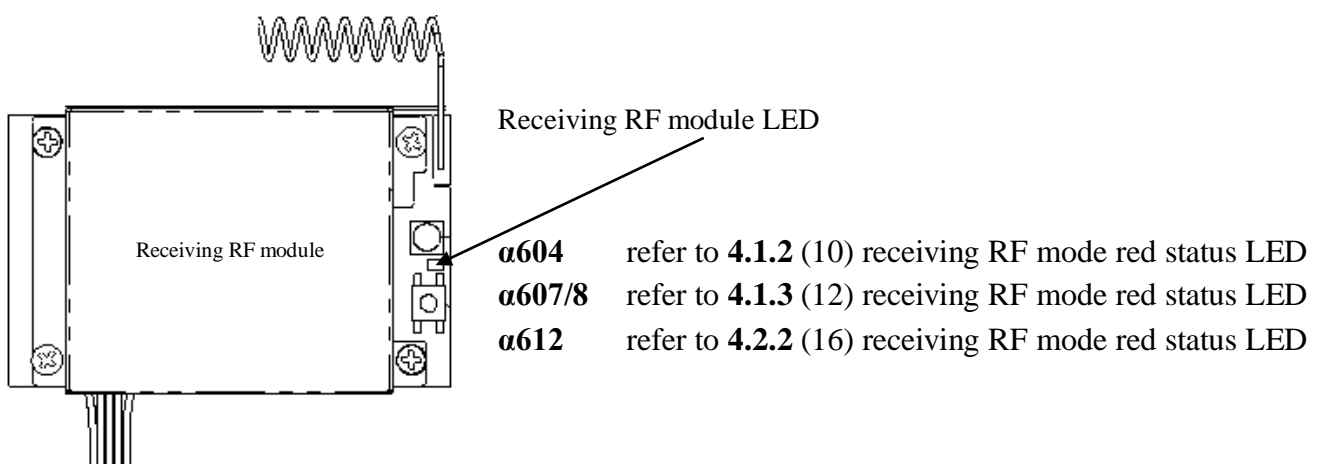

7.4 Steps for Receiving RF Module to Pair with Transmitter

* The pairing is for one transmitter to one receiving RF module only. No 2 transmitters or more than 2 enter pairing mode at the same time. Please refer to the pairing steps as below:

1. **Receiving RF module**_Press and hold PAIR button until the pairing is successful. (Red status light is off, receiving RF module enters pairing mode.)
2. **Transmitter**_Rotate the transmitter power switch to OFF position and close it to the receiving RF module.
3. **Transmitter**_Press and hold Up/Down button at the same time, then rotate the power switch to ON position.
4. **Transmitter**_After the power switch is turned on, release Up/Down button and press WEST button (the 4th button). (The green status light flashes slowly => transmitter enters pairing mode)
5. **Receiving RF module**_Wait until the red status light blinks (0.1 sec On/0.1 sec Off).
 - 5-1 Receiving RF module: Blinks -> transmitter pairing successfully and the receiving RF module will memorize the pairing transmitter ID.
 - 5-2 Receiving RF module: If the blink status light is not appeared after 1 minutes, then turn off the transmitter and receiver power and start the pairing from step 1 again.
6. After pairing is successful:
 - 6-1 Receiving RF module: Release the transmitter PAIR button to end the pairing mode. (At this time, the red status light of the receiving RF module flashes slowly => It means the pairing with the transmitter is successful and can be operated normally.)
 - 6-2 Transmitter: Turn off the transmitter power to end the pairing mode and then turn on the transmitter again to operate normally.

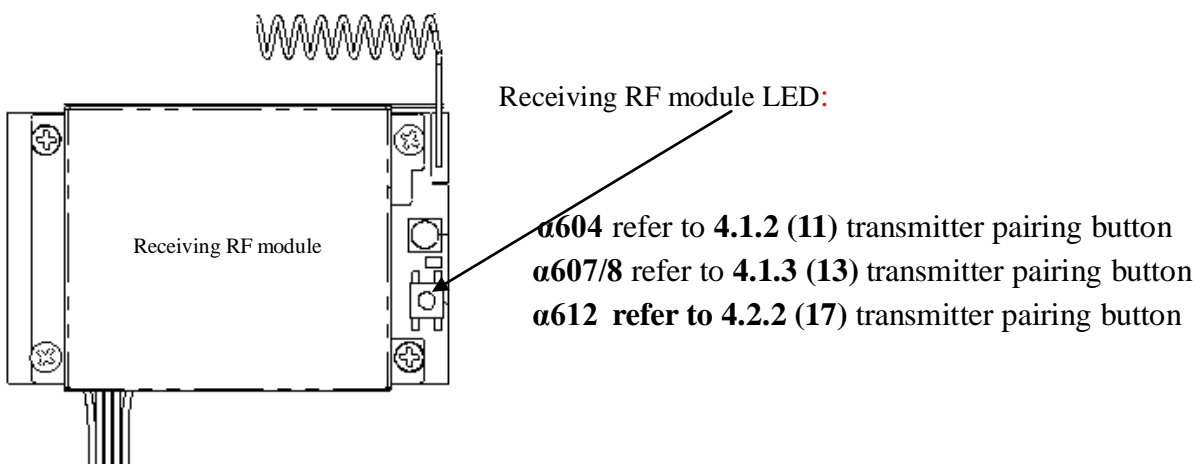

7.5 Receiver Function Settings

7.5.1 α 604/607/608 Receiver Function Settings

7.5.1.1 Set by the programming tool

Set from programming port CN5.

7.5.1.2. Adjust the jumper setting function on the decoder board

Adjusting the jumper setting to change the function selection (refer to Jump Set table as below):

* α600XJ series is for Mode 1 only.

JP1 : Insert short pin on α604/607/608. For power switch startup only.

JP2 : No function.

JP3 : “ JP3 (一) “__For α604AJ/BJ,607AJ/ATJ/BJ/BTJ and 608AJ/BJ.

“ JP3 (二) α608T only” __For α608ATJ/BTJ.

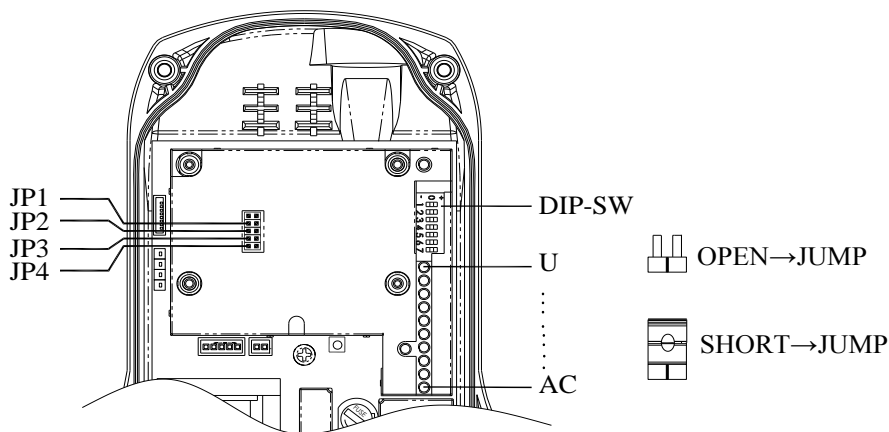

Jumper Set table: in-plant setting (default).

JP1	Open	Not available
	Short	Transmitter power switch start (when MAIN is off)
JP2	Open	No function
	Short	No function
JP3(*1)	Open	When the transmitter voltage is low, LV relay activates/deactivates every second.
	Short	* 4 pushbuttons: When either relay of pushbutton 1~4 is activated, LV relay will also be activated. * 8 pushbuttons: When either relay of pushbutton 1~6 is activated, LV relay will also be activated. * 12 pushbuttons: When either relay of pushbutton 1~8 is activated, LV relay will also be activated.
JP3(*2) α608T only	Open	MAIN relay off, I & II relays remain unchanged
	Short	MAIN relay off, I & II relay off.
JP4	Open	7 th AUX pushbutton: Set as “Normal”
	Short	7 th AUX pushbutton: Set as “Toggle”

“Start” means: MAIN relay unlatches and then latches.

※ Open → no Jumper

Short → put Jumper

7.5.2 α612 Receiver Function Settings

7.5.2.1 Set by the programming tool

Set from programming port CN5.

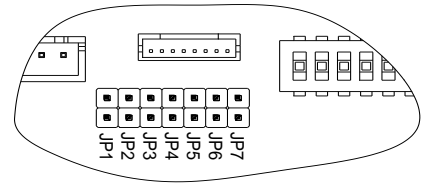

7.5.2.2 Adjust Jumper setting function on decoder board

Receiver function setting:

Jumper Set Table: In-plant setting (default).

JP1	Open	Not available
	Short	Transmitter power switch start (when MAIN is off)
JP2	Open	No function
	Short	No function
JP3	Open	When the transmitter voltage is low, LV relay activates/deactivates every second.
	Short	When either relay of pushbutton 1~8 is activated, LV relay will also be activated.

“Start” means: MAIN relay unlatches and then latches. JP1/JP2 is for Mode 0, Alpha 600-J series is for Mode 1 only:

JP1 setting is not available. Please proceed setting only when power is off.

JP2 No function

※ *Open* → *No jumper*

Short → *Put Jumper*

7.5.3 Alpha 612 Models Dip-Switch Function Table

※ In-plant all set as “0”

Model	Pushbutton	Dip-Switch Setting		Description	
612AJ	1 & 2 3 & 4 5 & 6	DIP 1	→ 1	Not Interlocked	
			→ 0	Interlocked	
	7 & 8	DIP 2	→ 1	Not Interlocked	
			→ 0	Interlocked	
	7 & 8	DIP 3	→ 1	Latching/toggle relay contact	DIP2 set at “1”
			→ 0	Momentary relay contact	
	9 & 10	DIP 4	→ 1	Not Interlocked	
			→ 0	Interlocked	
612BJ	9	DIP 5	→ 1	Latching/toggle relay contact	DIP4 Set at “1”
			→ 0	Momentary relay contact	
	10	DIP 6	→ 1	Latching/toggle relay contact	DIP4 Set at “1”
			→ 0	Momentary relay contact	

612BJ	7 & 8	DIP 1	→ 1 Not Interlocked	
			→ 0 Interlocked	
	7	DIP 2	→ 1 Latching/toggle relay contact	
			→ 0 Momentary relay contact	DIP4 Set at “1”
	8	DIP 3	→ 1 Latching/toggle relay contact	
			→ 0 Momentary relay contact	DIP4 Set at “1”
	9	DIP 4	→ 1 Latching/toggle relay contact	
			→ 0 Momentary relay contact	
612C-1J/ 612C-2J	1 & 2 (2 nd speed)	DIP 1	→ 1 Both 1 st and 2 nd speed contact relay interlocked when pressed to 2 nd speed	Both 1 st and 2 nd speed contact relays activated
			→ 0 Both 1 st and 2 nd speed contact relay activated when pressed to 2 nd speed	Only 2 nd speed contact relay activated
	9	DIP 2,3	→ 00 Momentary relay contact	
		DIP 2,3	→ 01 Latching/toggle relay contact	
		DIP 2,3	→ 10 Activate the 3 rd speed	
	10	DIP 4	→ 1 Latching/toggle relay contact	
→ 0 Momentary relay contact				
612DJ	1 & 2 (2 nd speed)	DIP 1	→ 1 Both 1 st and 2 nd speed contact relay interlocked when pressed to 2 nd speed	Both 1 st and 2 nd speed contact relays activated
			→ 0 Both 1 st and 2 nd speed contact relay activated when pressed to 2 nd speed	Only 2 nd speed contact relay activated
	---	DIP 2,3,4	→0 Momentary relay contact	DIP2&3 Must set to “0” all the time (In-plant set at “0”)
612E-1J/ 612E-2J	1 & 2 (2 nd speed)	DIP 1	→ 1 Both 1 st and 2 nd speed contact relay interlocked when pressed to 2 nd speed	Both 1 st and 2 nd speed contact relays activated
			→ 0 Both 1 st and 2 nd speed contact relay activated when pressed to 2 nd speed	Only 2 nd speed contact relay activated
	7 & 8	DIP 2	→ 1 Not Interlocked	
			→ 0 Interlocked	
7	DIP 3	→ 1 Latching/toggle relay contact		
		→ 0 Momentary relay contact	DIP2 Set at “1”	
612 AJ/BJ/C-1J/ C-2J/DJ/ E-1J/E-2J	11	DIP 7	→ 1 Latching/toggle relay contact	

7.5.4 Alpha 612 Receiver Voltage Settings

1. Select the voltage of the place where the receiver is installed.
2. Select the position of the “Y” terminal base on the label marked on the transformer.
If the default voltage setting is different from the place where the receiver is installed, please change the setting base on below steps:

- 2.1 Please first refer to below figure. Keep the “COM” end of the wire in the position as it is, remove the “Y” terminal from the other end of the wire, then screw the position originally with “Y” terminal tightly.
- 2.2 Select the voltage needed base on the label of the transformer. Unscrew the position on selected, put the “Y” terminal into the position selected and screw it tightly.

**Transformer type no. :
K-2367**

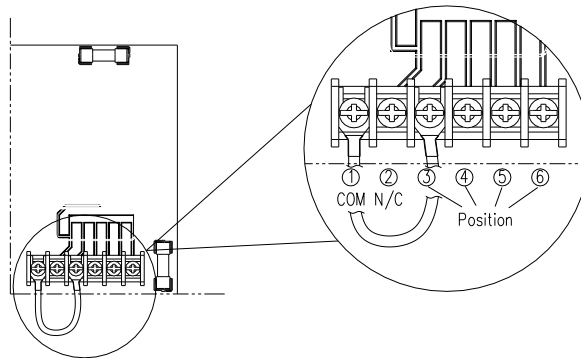

- Position ③ AC 110V → AC 100V ~ AC 125V
- Position ④ AC 240V → AC 200V ~ AC 240V

Transformer type no. : K-2368

- Position ⑤ AC 380V → AC 350V ~ AC 380V
- Position ⑥ AC 460V → AC 400V ~ AC 460V

Transformer type no. : SSB-2665

- Position ③ AC 24 V
- Position ④ AC 32 V
- Position ⑤ AC 36 V
- Position ⑥ AC 48V

DC power module :

PS12-24(A580)

- Position ② DC 12V ~ 24 V

3. Please make sure that the wire and the 5 screws are securely screwed.

7.6 Frequency (RF) Range

The frequency range of Alpha 600XJ group channel series is 902~928MHz. Please refer to 6.2.2 for more details.

8. TRANSMITTER OPERATION & STATUS LIGHT

8.1 Transmitter Operating Steps

1. Battery replacement steps



For induction charging, please use two “AA” low self-discharge NiMH (Nickel Metal Hydride) Batteries.

- A. Screw open the battery cover.
- B. Pull up the ribbon (to take out the exhausted batteries)
- D. & D. Put and press the first battery into the battery compartment. (Note the polarity and position)
- E. & F. Put and press the second battery into the battery compartment. (Note the polarity and position)

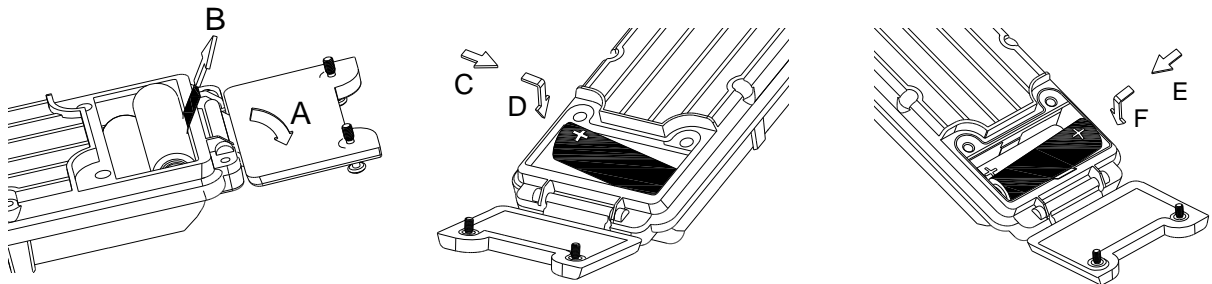

2. **Status lights** _To operate the transmitter, please rotate the power key on the top-left corner clockwise to “on” position. The status LED (green and red) will be steady “on” for 2 seconds and then “off”. If the transmitter Status LED displays a red blinking light that is “on” → 0.1 second and “off” → 1.9 seconds, or no light at all, this indicates the transmitter with batteries needs to be recharged. For battery charging or replacement, please refer to instruction next page.
3. When any function pushbutton is depressed, the transmitter Status LED displays a red blinking light that is “on”→ 0.1 second and “off”→ 1.9 seconds. If the voltage is low, the transmitter Status LED will be “on”→0.1 second and “off”→1.9 seconds, this indicates the transmitter with batteries needs to be recharged. Continuous operation will cause the transmitter battery power exhausting and cannot operate at all.
4. **EMS & Restarting** _ In case of an emergency, press down the red emergency stop button (EMS) will immediately deactivates the transmitter and receiver MAIN relay (Do not first switch off the power key in case of any emergency).
5. The emergency stop button is a right-rotate momentary spring-return type. To turn on the transmitter and activate the MAIN relay, please elevate the emergency stop button again and rotate the transmitter power key to “ON” position.
6. Note that the transmitter cannot be hit by outer force, so that malfunction can be prevented.
7. The operating temperature is -10 ~ +60°C. Avoid operating the transmitter in high temperature workshop. If operating temperature is higher than 80°C, the auto shutdown protection installed inside CPU will shut down the transmitter and deactivate the MAIN relay.

Under high temperature protection: Press every pushbutton will send null commands and the corresponding pushbutton relay will be unlatched. In case of high temperature protection functions, please keep the transmitter away from high temperature environment and shut off transmitter power. High temperature protection won't be deactivated only after transmitter is back to operating temperature -10 ~ +60°C and restarted.

8. To operation normally, the battery power must over 2.2V. If the voltage is lower than 2.2V, the system cannot be started and low voltage will be showed until the MAIN is completely shutdown.
9. If the power voltage is lower than 2.2V when transmitter is operated, the LV code will be "1" and low voltage status light will be shown. For standard version, the transmitter will stop sending signals when voltage is lower than 2.0V.

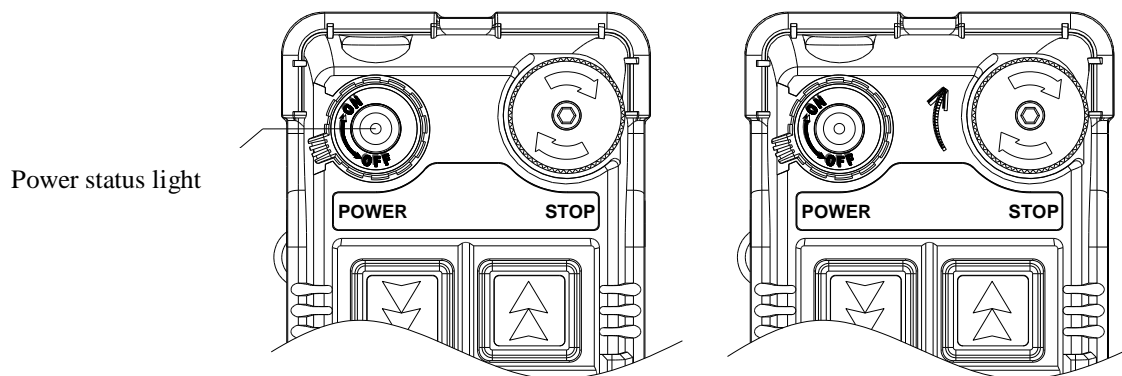

STOP: press → lock (emergency stop)

STOP: Elevate clockwise → reset (Turn on the transmitter at any time)

8.2 Transmitter Status Light

Type	Status	Problem	LED Indication
1	Charging	Place transmitter into charger	Constant red light ON
2	Power on when voltage is low	BATT<2.2V	Blinking red light flash ON_0.1/OFF_1.9 sec (until power off)
3	Setting failed or invalided	Set data by using JUMPER & dip-switch without following rules	Fast blinking on Red light ON_0.1/OFF_0.1 sec
4	Setting completed	JP1 or JP2 inserted	Constant green light ON until transmitter power shuts off.
5	EEPROM ID error	EEPROM ID code does not match CPU data	Constant red light ON until transmitter power shuts off
6	RF module abnormal	PLL UNLOCK	Red light ON_0.1/OFF_0.1 sec
7	Pushbutton locked	Power on pushbutton connected	Red light ON_1.9/OFF_0.1 sec (until power off)
8	Normal power on	BATT>=2.2V and all the pushbuttons are not depressed	All the lights ON_2 sec
9	STOP status	STOP button is pressed	MODE 1: all the lights OFF
10	Low voltage during operation	BATT<2.2V and press pushbutton	Red light flash ON_0.1/OFF_1.9sec

11	High temperature protection	encoder board temperature higher than 80°C	Press and hold the pushbutton: Blinking blinks ON_0.05/OFF_0.15 second All pushbutton released: All lights are off
12	Normal operation	Press pushbutton	Green light flash ON_0.1/OFF_1.9 sec

9. RECEIVER INSTALLATION

9.1 Preparation for Installation

- Required Tools for Receiver Installation:
 - Flat Head Screwdriver (-)
 - Phillips Head Screwdriver (+)
 - Multi-Meter
 - 14mm Wrench x 2
 - Power Drill with φ 10.5mm Drill-Bit
- Check to ensure that your receiver is not set to the same RF channel and ID code as any other systems in operation at the same facility or within 300-meter distance.
- Prior to installation, make sure that the crane or equipment itself is working properly.
- Use a multi-meter to check the voltage source available and ensure the receiver voltage setting matches your power source.
- Prior to installation, switch off the main power source to the crane or equipment.

9.2 Step By Step Installation and Commissioning

9.2.1 Select the location



Select the location for installation and wiring: (**Attention!!!**)

α 604/607/608 Systems

- For better reception, the location selected should have the antenna visible from all areas where the transmitter is to be used.
- The location selected should not be exposed to high levels of electrical noise. Mounting the receiver next to an unshielded variable frequency control (inverter) may cause minor interference. If it is unavoidable, please consider using antenna with external coaxial cable to relocate the antenna to better signal receipt position.
- Always locate the receiver unit as far away from high voltage wiring or equipment, such as: motor, relay, magnetic valve, inverter controls and output cable...etc. as possible. Be sure to install the receiver at least 2 meters away from the inverter. If the receiver is installed on the control box, then the antenna position has to be higher than the control box. (as Fig.11)

α 612 Systems

Drill four holes (dia.10.5mm) base on the position of the receiver shock absorbers. (Fig.12)

9.2.2 Commissioning steps

1. Decide the wiring type and cable. If the cable gland is used for the cable, please use the enclosed rubber cork to seal the cable gland without cable.
2. For system wiring, please refer to the output contact diagrams from page 13.
3. Ensure the selected location has adequate space to accommodate the receiver enclosure.
4. Make sure the receiver unit is in upright position (vertical).



The distance between the antenna and the control panel should be as far apart as possible. (refer to the fig.11 & 12).

5. If a crane or equipment's runway is longer than 100 meters, an external antenna should be added. The Alpha 608 receiver housing has provisions for an external factory installed antenna available as an option, contact your dealer for price and delivery.
6. Drill a hole on the control panel (10.5mm).
7. Tightened the bolt nuts provided.
- 8. If the control panel has a plastic surface, extended grounding wire should be used.**
9. Ensure all wiring is correct and safely secured and all screws are fastened.

The distance between receiver antenna and the control panel should be as far apart as possible.

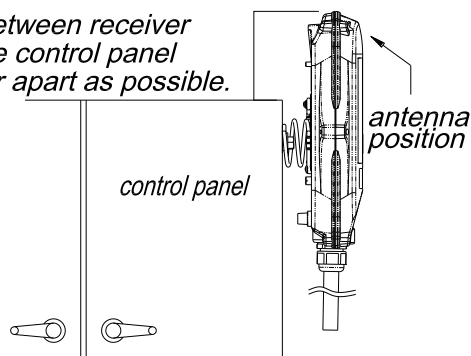

(Fig.11) Alpha 604, 607, 608 Models

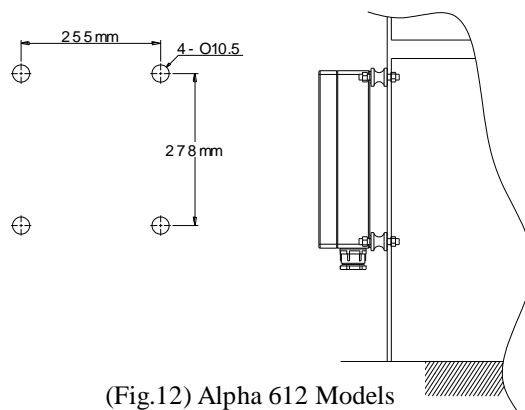

(Fig.12) Alpha 612 Models

9.3 System Testing

1. Connect the power source to the receiver and test the MAIN relay output by pressing the red emergency stop button (EMS) and observe that it properly opens and closes the main line disconnect contactor.
2. Test the operation of each function to ensure it corresponds to the transmitter direction labels and/or the pendant it is replacing.
3. Test the limit switches on the hoist and/or crane and verify they are working properly.
4. If your new remote control is replacing an existing pendant, make sure it is completely disconnected to prevent unwanted control commands, i.e. snick circuits.
5. If your new remote control is replacing an existing pendant make sure it is stored in a safe location where it will not interfere with remote operation (get torn off).

9.4 Receiver system Status LED Display

9.4.1. α604/607/608 Receiver System LED Display

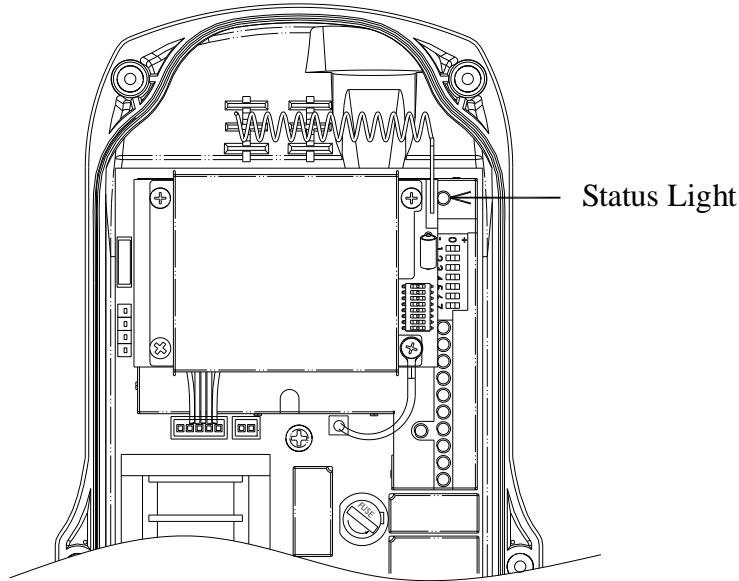

α604/607/608 Receiver system LED Display

Type	LED Indication	Problem and Solution
1	Constant flash red light.	EEPROM error – reprogramming required.
		Transmitter ON: Receiving signals from transmitter normally.
2	Dim or no light.	Under-voltage, check the MAIN relay power-supply.
3	ON → 2.0 seconds OFF → 0.1 second	MAIN contact relay jammed or defective.
4	ON → 0.1 second OFF → 2.0 seconds	Receiver under standby status.

9.4.2. α612 Receiver System LED Display

Receiver system LED Display

Type	LED Indication	Problem and Solution
1	Constant flash red light.	EEPROM error – reprogramming required.
		Transmitter ON: Receiving signals from transmitter normally.
2	Dim or no light.	Under-voltage, check the MAIN relay power-supply.
3	ON → 2.0 seconds OFF → 0.1 second	MAIN contact relay jammed or defective.
4	ON → 0.1 second OFF → 2.0 seconds	Receiver under standby status.

9.4.3 Alpha 612 Receiver System Status LED Display

LED Indication		Reason	Solution
Power LED display	ON	Normal-voltage	
	OFF	Under-voltage	
SQ LED display	ON	Transmitted signals detected and received	
	OFF	No transmitting signal detected	
	BLINK	1.Transmitter standby	Turn on the transmitter
		2.Interference	Turn off the transmitter
Relay LED display	ON	Normal operation	
	OFF	Receiver defective	Repair decoder board

10. BATTERY CHARGER

10.1 Charger Operation

Electromagnetic Induction Charge

- The electromagnetic induction charger with undisclosed metal charging contacts on transmitter provides immediate charging simply by sliding the transmitter into the charger. It is no need to open the battery cover to replace batteries.
- To avoid rain, high temperature, humidity and corroding air, please place or install the battery charger indoor with good ventilation. Keep 5cm space for two sides of the charger to keep the heat out. The suggesting temperature range is 0 ~ 40°C .

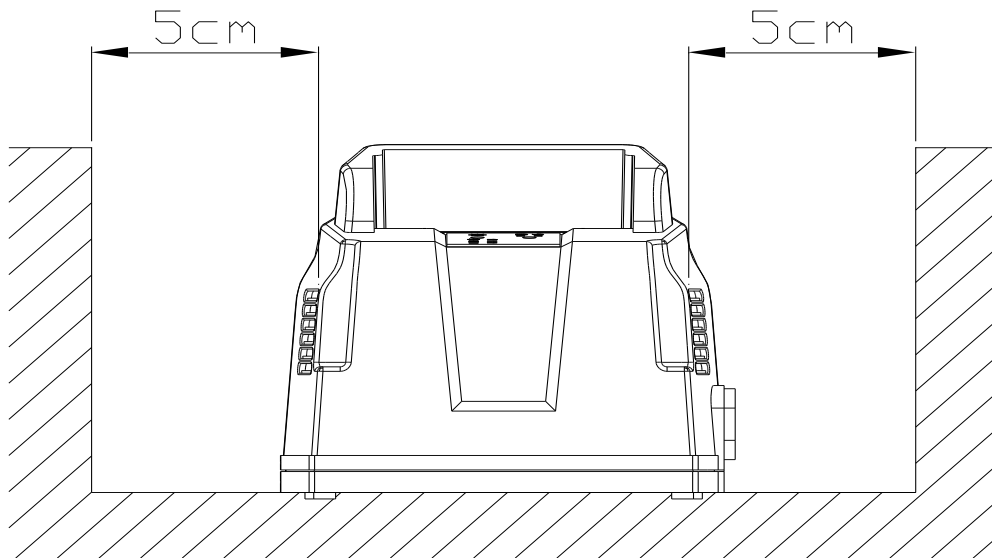

(Fig. 13) Front view

- Battery charger voltage AC100~240V 50/60Hz, power consumption 10W ◦
- Use Nickel-Metal low self-discharge Hydride (NI-MH) 2000mA, AA size*2 rechargeable batteries. Charging can be completed in 4 hours.
- Set the power switch on the OFF position whenever transmitter is not operated. Press E-STOP button and slide-in the transmitter into the charger to charge. The transmitter is suggested to be charged whenever it is not operated. The power switch should be rotated to OFF position while charging, otherwise charging cannot be proceeded.
- The charger status light shows red when transmitter is charging; transmitter status light will be off when charging is completed or failed. Please refer to below Battery Charger LED Status Light for details. After charging is completed, the charger status light shows green.
- When the rechargeable batteries are placed under low temperature environment, the activity is low and the “charging completed” LED will display in a shorter time than usual. To avoid such condition, please recharge the batteries within 0 ~ 40°C. Under lower temperature environment (below 0°C), the running down batteries will complete charging within half an hour. That means the charging is completed earlier than scheduled. Please take out the transmitter from the charger and insert it into charger again to proceed with charging normally.
- If the rechargeable batteries are not used for a longer period of time, the charging will be completed

in a shorter time than usual. To charge normally, please take out the transmitter from charger and insert it into charger again.

- Transmitter charging temperature might be abnormally high and then cause charging failed when the rechargeable battery is old. To avoid it, please replace old batteries with new ones.
- Please change the two rechargeable batteries from the transmitter battery compartment at the same time to charge or discharge completely.
- Charging will stop after induction charging is completed, failed or the transmitter is removed from the charger. The charger radiation fan will also be deactivated. To prolong charger life, its radiation fan will continue activating for another 3 minutes for heat radiation if the temperature of induction charging coil is higher than 40°C. If induction coil temperature is lower than 35°C during the 3 minutes of delay time, the radiation fan will deactivate immediately.
- Charger power LED: green

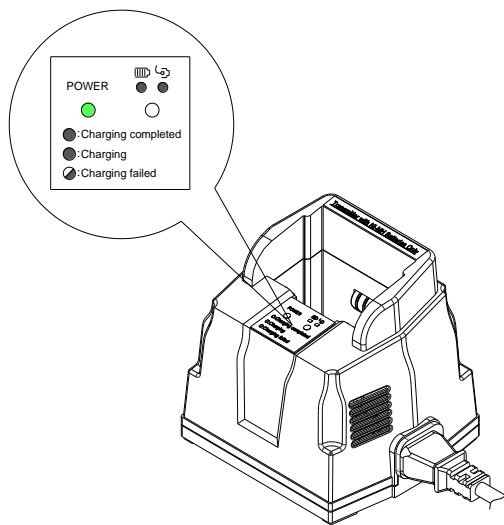

Slide-in transmitter into battery charger (transmitter vinyl protective cover has to be taken off)

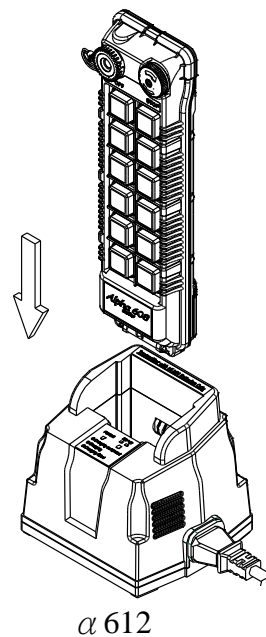
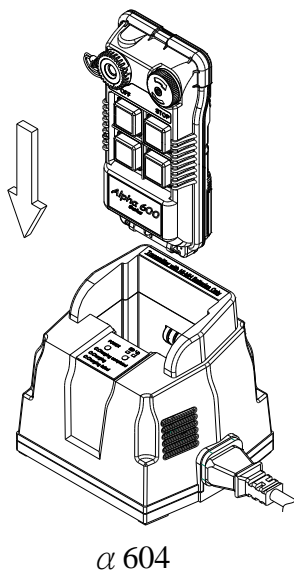

THE RECHARGEABLE BATTERIES HAVE TO BE RECHARGED WITHIN 6 MONTHS AFTER THE MANUFACTURING DATE.

10.2 Battery Charger LED Status Light

Item	Status	Condition	Status Light
1	Startup check	Within 2 seconds after power is on	Red + Green LED for 2 sec
2	Charging failed	No battery inside the transmitter battery holder or non-rechargeable battery is used/transmitter with abnormally high charging temperature.	Red LED ON_0.5/OFF_0.1 sec
		Charger with abnormally high temperature while it is standby or charging.	Red LED ON_1.9/OFF_0.1 sec
3	Charging	Charging procedure is normal	Red LED ON
4	Charging completed	Charging procedure is completed	Green LED ON
5	Standby	No transmitter in the charger	Not lit

11. TROUBLE SHOOTING

Should the operator find the equipment not operating normally, please check the chart below for simple trouble shooting tips.

Problem	Possible Reason	Solution
Transmitter does not communicate with the receiver.	Battery low or no voltage.	Turn “on” the transmitter with EMS elevated. If the status LED shows blinking red light or no light at all, then turn the power “off” and replace the two alkaline “AA” batteries.
Transmitter does not communicate with the receiver.	Turn on the transmitter with emergency stop button depressed.	Elevate the emergency stop button, turn off the transmitter and turn on again.
No power to the receiver (AC power indicator on the receiver unit not lit).	Blown fuse or no input power connection.	Ensure power input to the receiver unit is correct. If the power indicator (AC) is still not lit, please check the receiver for any open fuse.
Abnormal outputs.	Receiver configuration is not set properly or output wiring is incorrect.	Please refer to section 9 and 10 to ensure receiver is correctly wired and configured for your application.
Transmitter does not communicate with the receiver.	Transmitter and receiver are not bound. (SQ light is not on)	Proceeding with pairing. (refer to 7.2.2 receiving RF module pairing)

12. SYSTEM SPECIFICATION

Transmitter Unit

Source Voltage	:	Ni-MH AA size x 2 batteries 2.4V (no contact charging) Or AA size alkaline x 2 batteries 3.0V
Antenna Impedance	:	Internal Antenna 50 ohms. External antenna is available.
Dimension	:	604 Models : 140mm x 68mm x 30mm 607, 608 Models: 189mm x 68mm x 30mm 612 Models : 235mm x 68mm x 30mm
Weight	:	604 Models : 220g (include batteries) 607, 608 Models: 280g (include batteries) 612 Models : 350g (include batteries)
Enclosure Rating	:	IP-66
Operating Temperature	:	-10 ~ +60°C (> 80°C high temperature protection)
Transmitting Power Consumption	:	≒ 20mA@3V (Various from encoding mode and transmitting power)
Continue Operating Time	:	80hrs 1.5V@batteries full (2000mA)x2, Transmitting Power 10mW
Low Voltage	:	2.2V – 1.8V

Transmitting RF Board Unit

Frequency Range	:	902~928 MHz
Transmitting Power	:	1 mW – 100mW
Frequency Control	:	TCXO + PLL
Frequency Deviation	:	2ppm @ 25°C
Spurious Emission	:	< - 50dBc.
Emission	:	GFSK
Antenna Impedance	:	50 ohms
Operating Temperature	:	-10°C ~ +60°C

Charger Unit

Dimension	:	120mm x 105mm x 105mm
Voltage	:	100~240V 50/60Hz
Power Consumption	:	Max.10 Watt
Operating Temperature	:	0°C~ +40°C
Heat Ventilation	:	Temperature Control Fan
Charging Current	:	About 600mA @3V
Charging Time	:	About 3hrs @2000mAh
Charging Detection	:	- Δ V + Temperature

Receiver Unit

Frequency Band	:	BRX-915 (902~928 MHz)
Channel Spacing	:	500KHz
Frequency Control	:	PLL
Frequency Drift	:	< 2ppm @ -20°C ~ +70°C
Frequency Deviation	:	< 1ppm @ 25°C
Sensitivity	:	<-110dBm
Spurious Emission	:	- 50dB
Antenna Impedance	:	50 ohms
Responding Time	:	100ms (Standard)
Enclosure Rating	:	IP-66
Source Voltage	:	α604/607/608: DC12V-24V, AC48V, AC380V Full voltage module: AC100-240V @50/60Hz α612: DC12V-24V, AC24/32/36/48V, AC110V/240V, AC380-460V @50/60Hz
Power Consumption	:	α604: 8 Watt α607/8: 10 Watt α612: 16 Watt
Operating Temperature	:	-10°C ~ +70°C
Output Contact Rating	:	250V @ 5A
Dimension	:	604 Models : 310mm x 134mm x 72mm 607, 608 Models: 310mm x 134mm x 72mm 612 Models : 300mm x 230mm x 86mm
Weight	:	604 Models : 1,770g (include output cable) 607, 608 Models: 2,022g (include output cable) 612 Models : 3,500g (include output cable)

13. PARTS LIST

Transmitter

1. Transmitter RF module (All models)	BTXN433J
2. Encoder board (Alpha604AJ)	BEN604AJ
Encoder board (Alpha604BJ)	BEN604BJ
Encoder board (Alpha 607AJ)	BEN607AJ
Encoder board (Alpha 607BJ)	BEN607BJ
Encoder board (Alpha 607ATJ)	BEN607ATJ
Encoder board (Alpha 607BTJ)	BEN607BTJ
Encoder board (Alpha 608AJ)	BEN608AJ
Encoder board (Alpha 608BJ)	BEN608BJ
Encoder board (Alpha 608ATJ)	BEN608ATJ
Encoder board (Alpha 608BTJ)	BEN607BTJ
Encoder board (Alpha 612AJ)	BEN612AJ
Encoder board (Alpha 612BJ)	BEN612BJ
Encoder board (Alpha 612C-1J)	BEN612C-1J
Encoder board (Alpha 612C-2J)	BEN612C-2J
Encoder board (Alpha 612DJ)	BEN612DJ
Encoder board (Alpha 612E-1J)	BEN612E-1J
Encoder board (Alpha 612E-2J)	BEN612E-2J
3. Transmitter enclosure (Alpha 604)	BCT604
Transmitter enclosure (Alpha 607 & 608)	BCT607
Transmitter enclosure (Alpha 612)	BCT612
4. Battery cover	BC600
5. 2-step pushbutton	B50001
1-step pushbutton	B50002
6. EMS red cap (All models)	EMS01
7. EMS pushbutton mechanism (All models, red cap included)	B50003
8. Pushbutton rubber boot fixing holder (Alpha 604)	BFH604
Pushbutton rubber boot fixing holder (Alpha 607 & 608)	BFH607/608
Pushbutton rubber boot fixing holder (Alpha 612)	BFH612
9. Pushbutton rubber boot (Alpha 604)	PRB01
Pushbutton rubber boot (Alpha 607 & 608)	PRB02
Pushbutton rubber boot (Alpha 612)	PRB03
10. Transmitter shock-absorbing rubber (All models)	SAR02
11. Transmitter vinyl protective cover (Alpha 604)	VPC01
Transmitter vinyl protective cover (Alpha 607 & 608)	VPC02
Transmitter vinyl protective cover (Alpha 612)	VPC03
12. A600 waist strap (All models)	WS01
13. Ni-MH AA rechargeable battery	RCB01
Alkaline AA battery	ALB01
14. A600 pushbutton direction label	DL01

Receiver

	Part No.
1. 433MHz receiver RF module (All models, Group channel version)	BRX433J
2. Decoder board (Alpha 604A)	BDE604A
Decoder board (Alpha 604B)	BDE604B
Decoder board (Alpha 607A)	BDE607A
Decoder board (Alpha 607B)	BDE607B
Decoder board (Alpha 607AT)	BDE607AT
Decoder board (Alpha 607BT)	BDE607BT
Decoder board (Alpha 608A)	BDE608A
Decoder board (Alpha 608B)	BDE608B
Decoder board (Alpha 608AT)	BDE608AT
Decoder board (Alpha 608BT)	BDE608BT
Decoder board (Alpha 612A)	BDE612A
Decoder board (Alpha 612B)	BDE612B
Decoder board (Alpha 612C-1)	BDE612C-1
Decoder board (Alpha 612C-2)	BDE612C-2
Decoder board (Alpha 612D)	BDE612D
Decoder board (Alpha 612E-1)	BDE612E-1
Decoder board (Alpha 612E-2)	BDE612E-2
3. Receiver enclosure (Alpha 604/607/608)	BCR607
Receiver enclosure (Alpha 612)	BCR612
4. Receiver mounting spring (Alpha 604/607/608)	RMS600
5. Regular Output Contact Relay-blue (All Models)	RLY01
6. Safety MAIN Contact Relay-DC12V (All Models)	RLY02
7. Transformer (12-24VDC – Alpha 600-608, 612)	T24VDC
Transformer (48VAC – Alpha 600-608)	T48VAC
Transformer (110VAC – Alpha 600-608)	T110VAC
Transformer (220VAC – Alpha 600-608)	T220VAC
Transformer (230VAC – Alpha 600-608)	T230VAC
Transformer (240VAC – Alpha 600-608)	T240VAC
Transformer (380VAC – Alpha 600-608)	T380VAC
Transformer (25/36/42/50VAC – Alpha 612)	T25/36/42/50VAC
Transformer (110/240VAC – Alpha 612)	T110/240VAC
Transformer (380/460VAC – Alpha 612)	T380/460VAC
8. Full voltage module (100-240VAC-Alpha 600-608)	FV100-240VAC
9. 2-meter Output Cable with 5 Common Circuits Cable (24C*2m V3.5, Alpha 607, 608)	OC607
10. Optional External 433 MHz Antenna (All Models)	ANT433

Charger/USB programming parts

1. Charging board	CHPCB600
2. Electromagnetic board	ELEPCB
3. Charger casing	CHC600
4. Charging cable	CHCA
5. Charger holder	CHH600
6. USB programming board	USBPCB
7. USB connecting cable (1m)	USBC