

# *EXACT-V2*

## High End Rack Modulator / Exciter

- User Manual -



Document Reference:

MPD-1611291-A



**EXACT-V2 High End Rack Modulator / Exciter**

**Table of Content**

<b>1</b>	<b>System Overview</b>	<b>9</b>
1.1	General overview .....	11
1.2	Block diagram .....	12
<b>2</b>	<b>Features Summary</b>	<b>13</b>
2.1	Features Overview .....	15
2.2	Input Stream Interfaces .....	17
2.2.1	ASI/SMPTE Inputs.....	17
2.3	Input Stream Management .....	17
2.3.1	TS <i>CleverSwitch</i> Control .....	18
2.3.2	Seamless Switching .....	19
2.4	Modulation Core .....	19
2.5	Test modes operation.....	19
2.5.1	PRBS sequence.....	19
2.5.2	Sinus tone generation .....	19
2.6	Digital Precorrection.....	20
2.6.1	Digital Adaptive Precorrection.....	22
2.6.2	Manual Digital Pre-correction .....	25
2.6.3	Adaptive Linear pre-correction for sharp channel filters (in ATSC 1.0) .....	25
2.7	Output Processing.....	26
2.7.1	RF output muting and RF maintain features.....	26
2.7.2	Crest Factor Reduction Management .....	27
2.7.3	DAP Operation.....	30
2.8	Clock and Synchronization .....	32
2.8.1	GPS and clock management for VX20-x0x2.....	32
2.8.2	Warm-up Time .....	35
2.8.3	Loss of Reference Signal management (LORS) .....	35
2.9	Power Measurements .....	37
2.10	Automatic Gain Control (AGC) .....	38
<b>3</b>	<b>EXACT-V2 Rack</b>	<b>39</b>
3.1	EXACT-V2 mechanics .....	41
3.1.1	Front panel layout.....	41
3.1.2	Rear Panel Layout.....	42
3.2	Interface characteristics .....	42
3.3	Front Panel signalization (LEDs description) .....	52
3.4	Power requirements .....	53
3.5	Performances and technical characteristics.....	53
3.5.1	General characteristics .....	53
3.5.2	Control and data Ethernet interfaces .....	53
3.5.3	Serial control interfaces .....	54
3.5.4	ASI inputs / output and MPEG-TS processing.....	55
3.5.5	Digital modulation.....	56
3.5.6	Clock synchronization.....	57
3.5.7	RF and monitoring outputs.....	59

**EXACT-V2 High End Rack Modulator / Exciter**

3.5.8	Digital precorrection .....	60
3.5.9	Power level measurement inputs and AGC .....	61
3.5.10	Dry contacts .....	61
3.6	Conformity with EC Directive .....	62
<b>4</b>	<b>EXACT-V2 Installation</b>	<b>63</b>
4.1	Unpack the Unit .....	65
4.2	Installation and Recommendations .....	65
4.2.1	Temperature alarms .....	66
4.2.2	Cooling methods .....	66
4.3	Wiring and Powering on.....	66
4.4	Initial Configuration .....	67
<b>5</b>	<b>Operation</b>	<b>71</b>
5.1	Operation Generalities .....	73
5.1.1	Local Operation .....	73
5.1.2	Remote Operation .....	73
5.2	Embedded Web GUI Description .....	74
5.2.1	Requirements .....	74
5.2.2	Connection to EXACT-V2 .....	74
5.2.3	General Overview .....	75
5.2.4	Settings Tab .....	76
5.2.5	Monitoring Tab .....	78
5.2.6	Log File .....	79
5.3	Front Panel Menu Description .....	79
<b>6</b>	<b>Maintenance &amp; Troubleshooting</b>	<b>81</b>
6.1	Versions management.....	83
6.2	Software updates .....	83
6.3	Licence key management .....	84
6.4	Troubleshooting of the exciter .....	84
6.4.1	LED Check .....	84
6.4.2	Contact the technical support.....	85
<b>Appendix A</b>	<b>GPS Installation Recommendations</b>	<b>87</b>
<b>Appendix B</b>	<b>Example of GPS Antenna</b>	<b>91</b>

**EXACT-V2 High End Rack Modulator / Exciter****Revision sheet**

Document Number	Revision	Date	Version	Comments
MPD-1611291	A	Nov 2016	S100	Document creation ATSC 1.0 Version (ATSC 3.0 Ready)
MPD-1611291	B	Feb 2017	S100	Revised

**Warning****Content warning**

This document contains preliminary information about some of the products in the Hitachi-Comark family. Hitachi-Comark maintains the right to make changes to the documentation at any time without prior notice in order to improve, design and supply the best possible product.

**Copy warning**

This document includes some confidential information. Its usage is limited to the owners of the product that it is relevant to. It cannot be copied, modified, or translated into another language without prior written authorization from Hitachi-Comark.

**EXACT-V2 High End Rack Modulator / Exciter****About this manual****▪ Intended audience**

This user manual has been written for those who have to use, configure and install the product. Some chapters require some prerequisite knowledge in electronics and especially in broadcast technologies and standards.

**▪ Product described**

The following products are described in this user manual:

EXACT-V2  
EXACT-V2-20dB

**▪ Commercial references and available options**

Product ref.	Description
EXACT-V2 EXACT-V2-20dB	ATSC rack modulator with UHF/VHF* output, DAP and onboard GPS Optional +20dBm, output, DAP and onboard GPS
EXACT-ATSC 3 VP EXACT-ALP3	ATSC 3.0 software license (Single PLP) ALP software license (3.0)

\*Specify at the time of order: UHF, VHF Band 3, or VHF Band I

**▪ Document structure :**

- **Chapter 1 – System Overview**  
This chapter gives an overview of the product.
- **Chapter 2 – Features Summary**  
This chapter describes the features found in the product.
- **Chapter 3 – EXACT-V2 rack**  
This chapter describes the mechanics, characteristics and performances of the product.
- **Chapter 4 – Module Installation**  
This chapter explains how to install the product.
- **Chapter 5 – Operations**  
This chapter explains how to basically operate the product.
- **Chapter 6 – Maintenance and Troubleshooting**  
This chapter gives recommendation on how to maintain the product and how to perform first level Troubleshooting in the event of technical issues.

# EXACT-V2 High End Rack Modulator / Exciter

## ▪ Associated publications

The reader of this document could improve their understanding of the product and its effective use by reading the following documents:

[A1]	ATSC standards	A/53, A/54
	<a href="http://www.atsc.org/standards.html">http://www.atsc.org/standards.html</a>	
[A2]	DVB Measurements	ETSI TR 101 290 v1.2.1
	<a href="http://www.dvb.org">www.dvb.org</a>	
[A3]	ATSC Compliance	A/64
	<a href="http://www.atsc.org/standards.html">http://www.atsc.org/standards.html</a>	
[A4]	SFN Network in ATSC	A/111
	<a href="http://www.atsc.org/standards.html">http://www.atsc.org/standards.html</a>	

**Table 1: Relevant standards for ATSC**

[A6]	Physical Layer Protocol	A/322
	<a href="http://atsc.org/standards/atsc-3-0-standards/">http://atsc.org/standards/atsc-3-0-standards/</a>	
[A7]	Link-Layer Protocol	A/330
	<a href="http://atsc.org/standards/atsc-3-0-standards/">http://atsc.org/standards/atsc-3-0-standards/</a>	

**Table 2: Relevant standards for ATSC 3.0**

[D1]	DVB ASI	EN50083-9, ETSI TR101 891 v1.1.1
	<a href="http://atsc.org/standards/atsc-3-0-standards/">http://atsc.org/standards/atsc-3-0-standards/</a>	
[D2]	MPEG-2 TS Standard	ISO/IEC 13818-1
	<a href="http://www.iso.org">http://www.iso.org</a>	

**Table 3: Other standards**

[I1]	IP	RFC-791
	<a href="http://www.ietf.org">www.ietf.org</a>	
[I2]	UDP	RFC-768
	<a href="http://www.ietf.org">www.ietf.org</a>	
[I3]	RTP & MPEG/RTR	RFC-1889 / RFC-2250
	<a href="http://www.ietf.org">www.ietf.org</a>	
[I4]	IP Multicast	RFC-2365
	<a href="http://www.ietf.org">www.ietf.org</a>	
[I5]	Ethernet	IEEE-802.3
	<a href="http://www.ieee802.org/3/">http://www.ieee802.org/3/</a>	
[I6]	Multicast protocol IGMP	RFC-2236 / RFC-3376
	<a href="http://www.ietf.org">www.ietf.org</a>	

**Table 4: Relevant standards for IP**

**EXACT-V2 High End Rack Modulator / Exciter**



**EXACT-V2 High End Rack Modulator / Exciter**

---

# 1

## System Overview

---

**EXACT-V2 High End Rack Modulator / Exciter**

## EXACT-V2 High End Rack Modulator / Exciter

### 1.1 General overview

EXACT-V2 exciter has been especially designed to support, in addition to ATSC 1.0, the complex ATSC 3.0 modulation scheme, including Digital Adaptive Pre-correction (DAP) circuits and all required mechanisms to feed transmitters with flexible and highly secured input stream formats. This ready-to-use high-end 1RU exciter offers the best-in-class performance for broadcasters that want to launch ATSC 1.0 or ATSC 3.0 products with a high-performing, secured solution. Enabling users to migrate ATSC 3.0, reusing and recycling their existing transmission system, this unique exciter significantly reduces capital expenditure (CAPEX) costs.

In order to bring the highest performance, EXACT-V2 integrates up-to-date FPGA technology and sophisticated digital signal processing algorithms, especially for the modulation and the output filtering processes. With this in mind, broadcasters are able to take full advantage of ATSC 3.0 technology.

The clock system has been carefully designed to reach a very low phase noise and it achieves the flexibility required to operate with different synchronization schemes. EXACT-V2 includes a high-stability OCXO oscillator and an on-board GPS receiver. It generates a fully modulated analogue signal and includes all necessary clock & synchronization features for high quality ATSC 3.0 synchronization, especially for SFN networks.

Fully controlled via a user friendly WEB GUI and via SNMP (optional), EXACT-V2 also features some very unique functionalities such as a Power Measurement Unit (measuring in real-time the forward and reflected power levels), the TX power ON/OFF control and the Automatic Gain Control (AGC) mechanism. EXACT-V2 Digital Adaptive Pre-correction (Digital Adaptive Processing) algorithm, permits transmitter operation very close to the saturation limit with unequalled RF signal performance and allows for significant gain in transmitter Power Efficiency. This generates significant savings in operating expenses (OPEX).

Three Ethernet control ports are available, which provides the opportunity to upgrade a legacy transmitter configuration into a fully IP-controlled solution!

**EXACT-V2 High End Rack Modulator / Exciter**

**1.2 Block diagram**

The generic block diagram is described below:

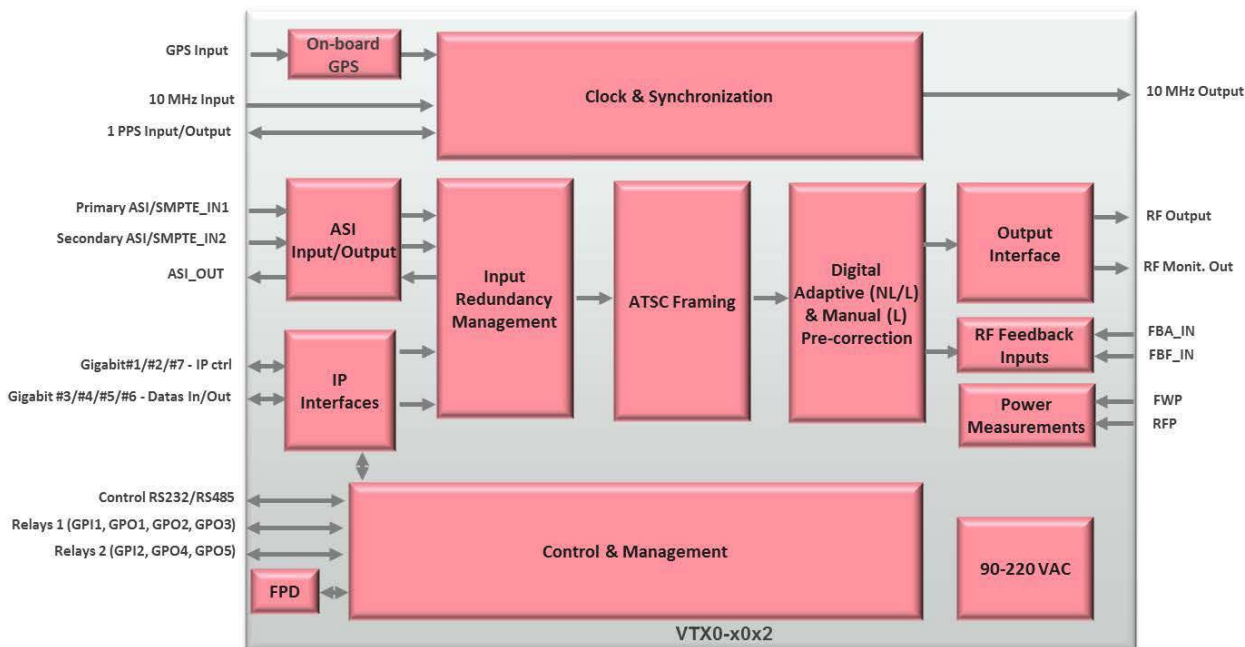

**Figure 1: EXACT-V2 functional block diagram**

EXACT-V2 features two ASI/SMPTE input streams that can be processed in parallel for stream redundancy (Primary/Secondary). Four IP streaming (Gigabit) input/output ports are reserved for ATSC 3.0 mode.

The clock and synchronization process has been carefully designed to reach the best performance for all of the supported standards. 1PPS and 10MHz external reference signals are available to reach a higher frequency accuracy. An on-board GPS receiver is also available and may be used for this purpose.

Regarding the control and management of EXACT-V2, an embedded web server provides a user-friendly graphical user interface (GUI) that can be accessed by any web browser. Three IP control ports are available.

Two connectors are provided for the feedback inputs from the amplifier (FBA\_IN) and from the filter (FBF\_IN). These inputs are used for the Digital Adaptive Precorrection (DAP).

A serial port is also available for complete transmitter control and monitoring integration within the modulator's Web GUI.

**EXACT-V2 High End Rack Modulator / Exciter**

---

# 2

## Features Summary

---

**EXACT-V2 High End Rack Modulator / Exciter**

## EXACT-V2 High End Rack Modulator / Exciter

### 2.1 Features Overview

- Input Stream Management

#### **ATSC 1.0 :**

- 2x ASI/SMPTE 310M Inputs :
  - ✓ ASI: 188 or 204 byte format with RS decoding – TS/ASI (ETSI EN 102 773 - [\[D1\]](#) & [\[D2\]](#))
  - ✓ SMPTE 310M: 188 byte format
- 1x ASI Output (188 byte) – Stream output type: TS/ASI
- Redundancy management :
  - *TS CleverSwitch*: stream switching between Main and Secondary input – See [TS CleverSwitch control](#)
- Bit rate adaptation & PCR re-stamping
- Null packet deletion

- ATSC framing and channel encoding

- 8-VSB modulation core
- Virtual Channel Table Update

#### **ATSC 3.0 : (Available from the S110 firmware version)**

- Digital Adaptive Non-Linear Precorrection circuits
  - Flexible operating modes: STATIC (EDIT), SINGLE, SURVEY or CONTINUOUS
  - RF feedback signals sampled in real-time after Power Amplifier
- Digital Linear Precorrection circuits
  - Manual mode
  - Adaptive mode : STATIC (EDIT) or SINGLE
  - RF feedback signals sampled in real-time after RF filter
- PAPR reduction system and protection clipping
- RF output
  - Frequency band: UHF and VHF band
  - Bandwidth: **6MHz**
  - Main output (0dBm or optional +20dBm) and monitoring output (-20dB relative to main output)

## EXACT-V2 High End Rack Modulator / Exciter

- Manual mute and programmable mute condition on LORS
- RF maintain function on stream input loss
- Clock and synchronization signal management
  - External reference sources: 1PPS, 10MHz inputs
  - Onboard GPS (VX20-x0x2)
  - 10 MHz reference output
  - LORS management
- Measurement/Monitoring
  - ATSC1.0: MER and shoulder level monitoring (indicative)
  - 2 dedicated inputs for forward and reflected powers measurement
- AGC feature
  - Capacity to automatically adjust the output power to ensure a stable system output power
  - Feedback input using direct adapted RF signal from amplifier output (-10dBm) or VDC signal from external power sensor
- Control and Management
  - Control and monitoring via web based GUI
  - LCD front panel for main features control and monitoring
  - 4 front panel status LED's
  - Alarm relays
  - 1+1 Redundancy proprietary management
  - 2 Ethernet control ports on rear panel
  - 1 Ethernet control ports on front panel
- Transmitter Environment Interface
  - Full control/monitoring using seamless Web GUI
  - Based on Hitachi-Comark serial protocol and integrated serial port
- Other
  - 110-240 VAC
  - 1RU rack form factor

**Note:** Availability of features depends on software release version. (Please refer to the product release notes).



## EXACT-V2 High End Rack Modulator / Exciter

### 2.2 Input Stream Interfaces

#### 2.2.1 ASI/SMPTE Inputs

The unit offers 2 ASI/SMPTE inputs compliant either with DVB-ASI ([D1] & [D2]) or with SMPTE 310M. They can be used either in single or redundant mode. 188 or 204 byte packets without RS coding and 204 byte packets with RS coding are supported when used in ASI mode. If 204 byte packets including RS coding are provided, then the RS error checking and correction are performed. Both ASI "Packet mode" and "Burst mode" are supported. When used in SMPTE 310M mode, only 188-byte format is supported.

#### Input Equalizer

Each input has an equalizer that can be turned ON or OFF. This equalizer works well to equalize cable length attenuation but does not perform as well if the input cable is mismatched. If this is the case, and in the case of SMPTE 310M input mode being used, the Equalizer should be turned off.

### 2.3 Input Stream Management

The Stream Management consists in routing the incoming data from the ASI/SMPTE or the Ethernet interface towards the modulation core. This part can manage all types of interfaces and it also provides the TS output stream for the ASI output interface. The Stream Management process might operate additional basic functions such as data monitoring, data extraction, bit-rate adaptation and routing.

**Bit-rate adaptation:** When using an external clock reference, the global clock synchronization might be plesiochronous (i.e. small clock deviance between the multiplexer and the modulator reference). In that case, it is recommended to enable the bit rate adaptation. When this mode is activated, the unit discards or inserts null packets in order to accurately adapt the TS input bit-rate to the bit-rate defined by the selected ATSC mode. PCR re-stamping is then executed accordingly.

At last, an ASI output has been designed for copying either one of the input streams (ASI1, ASI2 or the TS from the active IP input) on the Active\_Stream.

**EXACT-V2 High End Rack Modulator / Exciter**

**2.3.1 TS CleverSwitch Control**

*CleverSwitch* is a flexible input redundancy management mechanism designed by Hitachi-Comark. It is enabled by default and can be manually disabled or enabled.

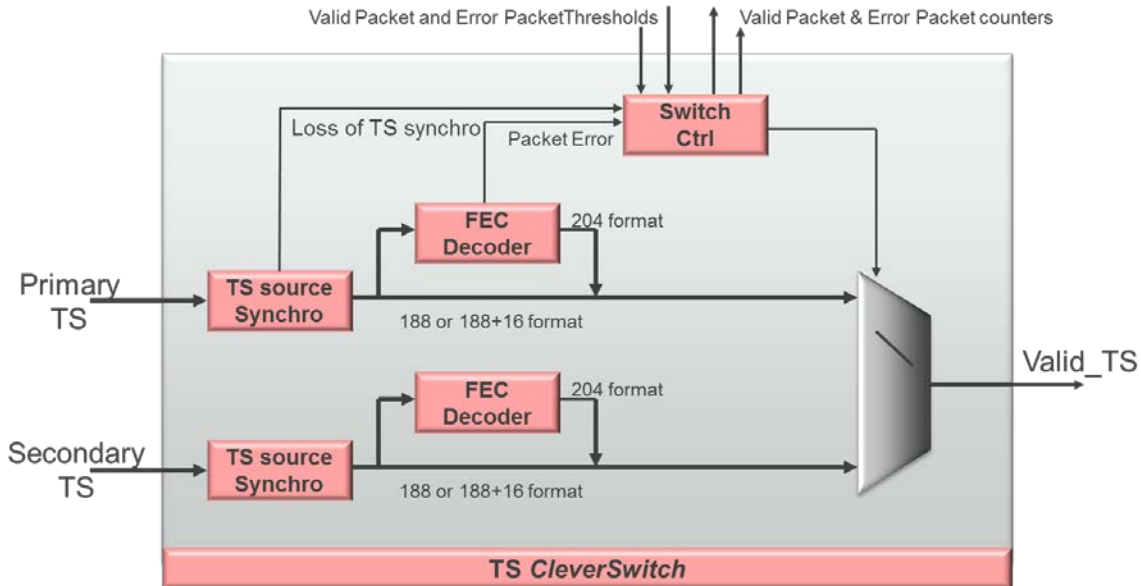

**Figure 2: TS CleverSwitch block diagram**

*CleverSwitch* is based on a programmable consecutive error threshold. Once it is reached, the stream selection switches automatically from the primary input to the secondary. When the valid packets threshold is reached, the stream input switches back to the primary. In 188 byte format, the switch criteria only considers the number of consecutive valid and error packets (0x47 sync detection), whereas in 204 byte mode, it also uses the RS errors. The switch decision is implemented only on the primary input. The switch-back is manual or automatic in case of secondary signal failure.

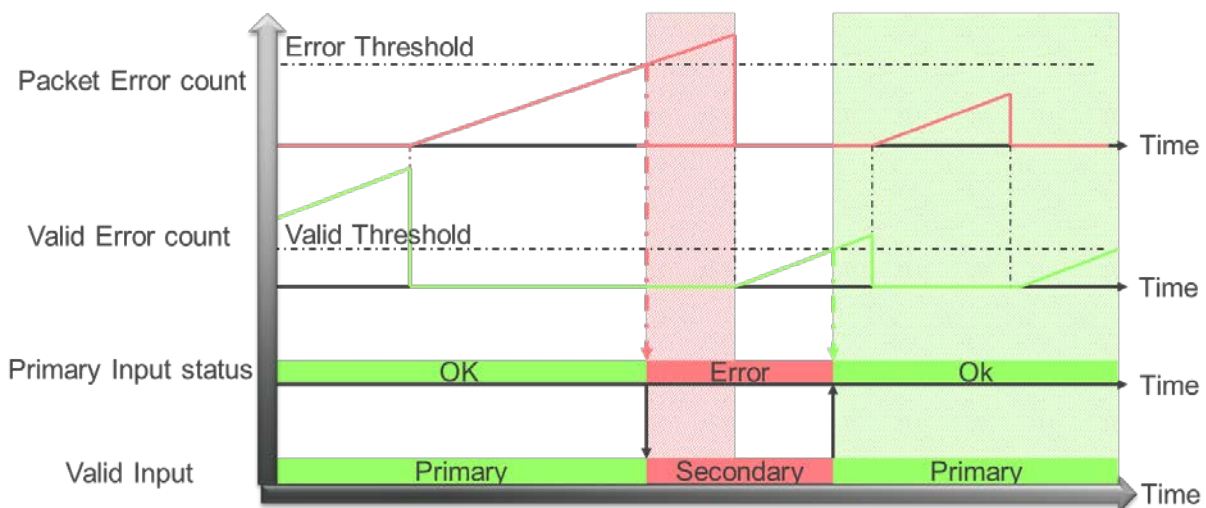

## EXACT-V2 High End Rack Modulator / Exciter

### 2.3.2 Seamless Switching

The switching (and switching back) performed by the TS CleverSwitch between the primary and the secondary stream is not expected to be seamless. However, if the exact same data stream is present on both inputs (Primary & Secondary) then the modulator performs seamless switching between inputs. Switching is made on a packet basis.

### 2.4 Modulation Core

The modulator is fed by the active TS stream coming out of the *CleverSwitch*. It then delivers IQ samples towards the Digital Pre-corrector.

From S110 version, it will support both ATSC 1.0 and ATSC 3.0 standards in the same firmware. The user just selects the desired standard using a simple command.

In ATSC 1.0:

VCT (Virtual Channel Table) updates allows the user to change the major channel number and carrier frequency.

In ATSC 3.0:

(Available from the S110 firmware version)

### 2.5 Test modes operation

#### 2.5.1 PRBS sequence

A PRBS sequence can be internally generated and inserted at the input of the modulator instead of an external MPEG-TS or IP Packets. The PRBS polynomial coefficients are configurable.

#### 2.5.2 Sinus tone generation

Two sinus tone modes are available: sinus and +6dB Boosted sinus. In these modes, the output RF signal is replaced by a simple sinus wave at the RF frequency. The boosted mode allows phase noise measurement without the requirement of an external amplifier. Sinus tone generation should only be used if the exciter is being bench tested (ie. not connected to the transmitter).

**Note:** Use of either sinus tone might damage the power amplifier.

**EXACT-V2 High End Rack Modulator / Exciter**

**2.6 Digital Precorrection**

The digital pre-correction feature is available for both ATSC 1.0 and ATSC 3.0 signal waveforms.

The digital precorrection feature consists of two types of correction:

- o Linear precorrection for compensating the distortion due to the channel filter
- o Non-linear precorrection in order to cope with the power amplifier distortion

Digital precorrection can be:

adaptive: running automatically thanks to an internal (DAP) algorithm

manual: curves are set via **TuneCast** software (using IP connection)

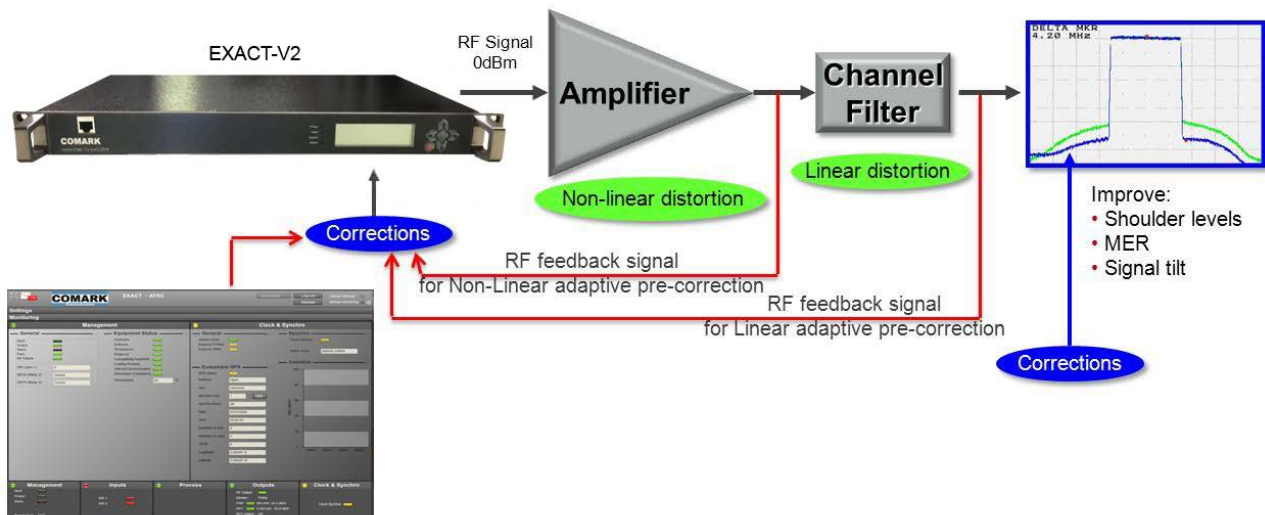

Web GUI for manual (Linear) Pre-correction

The EXACT-V2 product integrates both Linear and Non-Linear Digital Adaptive Precorrection, as well as Linear manual precorrection.

**Figure 3: Linear & Non-Linear Precorrection methods**

**EXACT-V2 High End Rack Modulator / Exciter**

The use of adaptive precorrection is generally preferred not only in order to reach higher performance and efficiency, but also in order to save on technician time. However, when several RF signals are combined together (adjacent channels), the use of Linear DAP is not possible because the feedback signal is then a combined spectrum of several channels. In that case a manual Linear precorrection is needed.

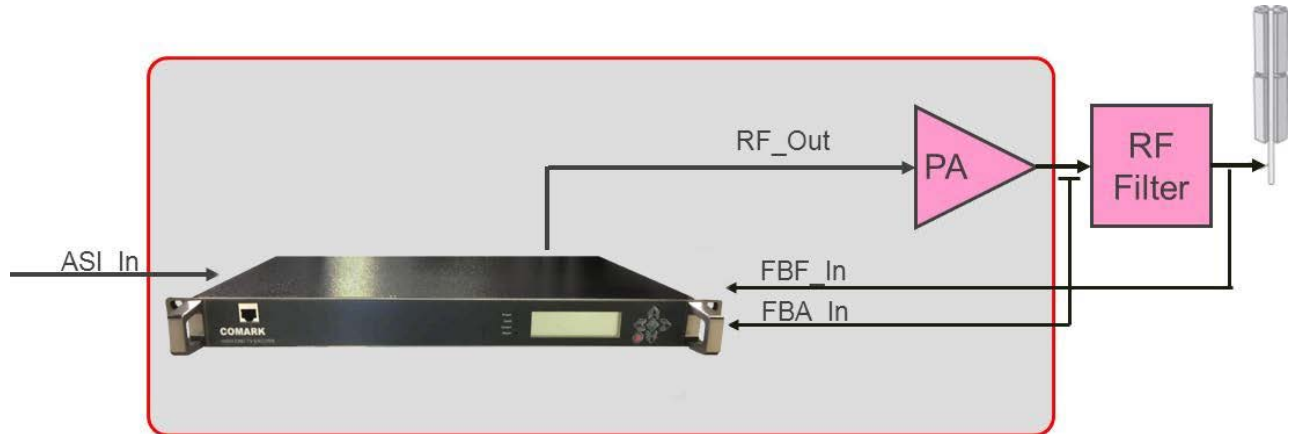

**Figure 4: Linear DAP typical use-case**

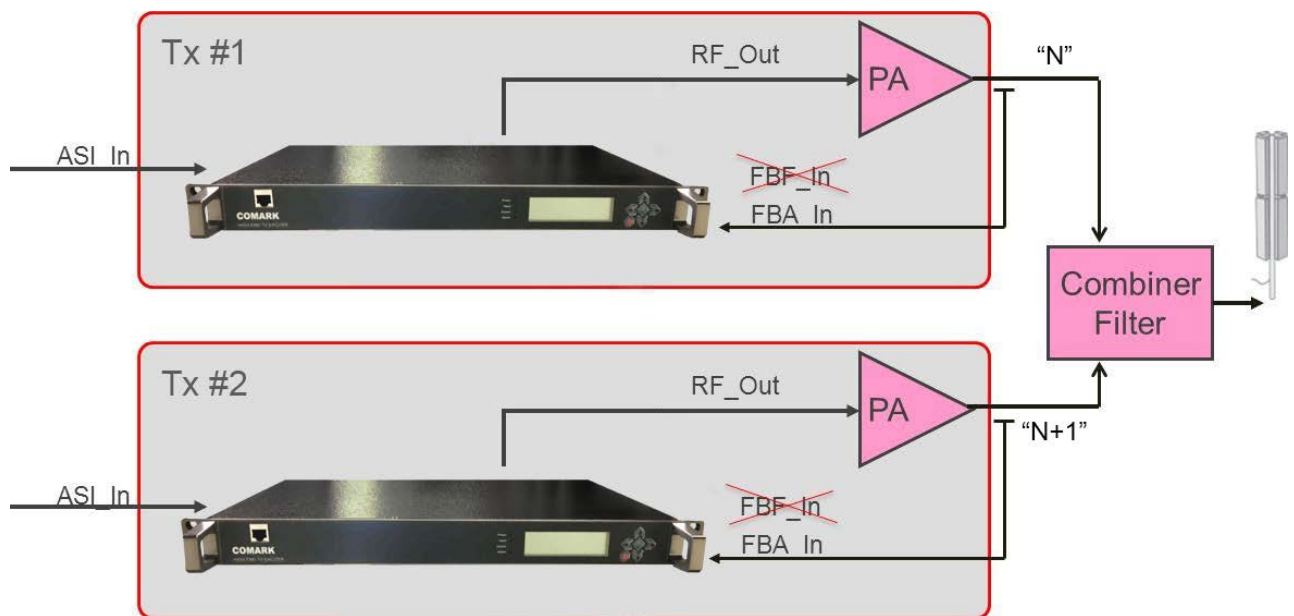
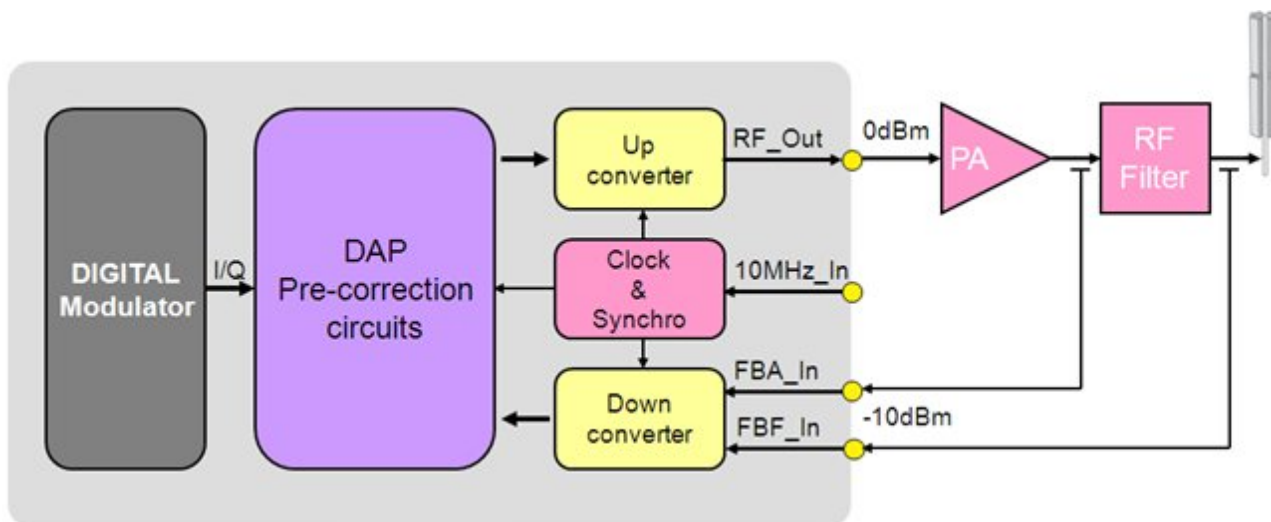

**Figure 5: Manual Linear Precorrection use-case – Combined filter**

**EXACT-V2 High End Rack Modulator / Exciter**

**2.6.1 Digital Adaptive Precorrection**

The Digital Adaptive Precorrection (DAP) block is illustrated here below.



**Figure 6: DAP integration block diagram**

The DAP function is composed of Non-Linear and Linear Precorrection and a dedicated down-converter. The down-converter receives the signal feedback after the external amplifier (FBA\_In) and after the RF filter (FBF\_In). Then, a particular algorithm processes the digital IQ samples to reduce the signal distortions at the transmitter output.

To monitor the DAP process several statuses are available:

- ✓ MER indicative measure
- ✓ PAPR indicative measure
- ✓ Measured left and right shoulder levels
- ✓ DAP elapsed time
- ✓ DAP status: Active, Stopped by user, Stopped by timer, Failed

**2.6.1.1 Non-Linear Adaptive Precorrection**

EXACT-V2 performs non-linear precorrection over a 75 MHz bandwidth. The purpose of non-linear precorrection is to correct the distortion from the power amplifier. With the feedback from the output amplifier, an adaptive non-linear precorrection should automatically find the best precorrection and follow the variations of the amplifier characteristics.

Four operating modes are available:

- **STATIC (EDIT) mode:** The DAP is disabled. The user can load a previous DAP configuration to be applied to the modulator.

**EXACT-V2 High End Rack Modulator / Exciter**

- **SINGLE DAP:** The DAP process is manually started and is stopped either by a timer value (user configurable) or manually stopped.

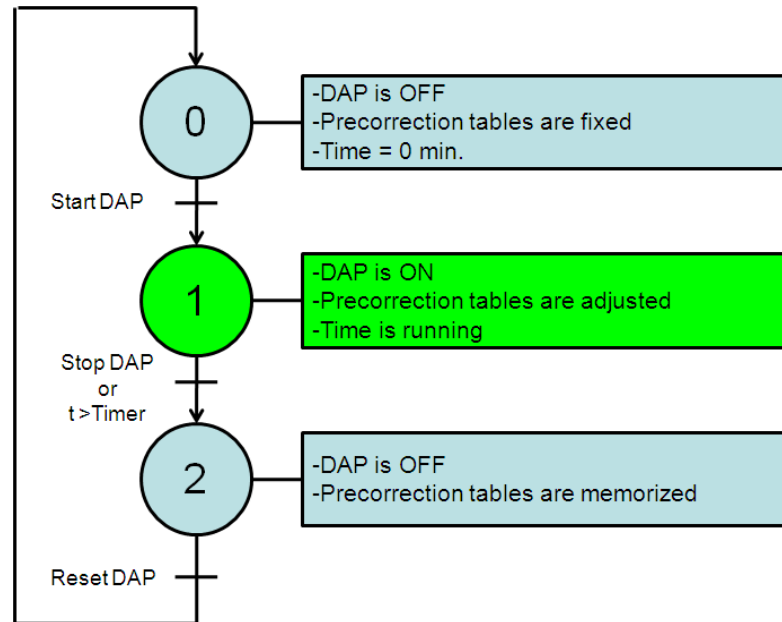

**Figure 7: Single DAP mode operation**

- **SURVEY DAP:** In this mode, the DAP process is started as the Single DAP mode. Once the timer is reached, then the DAP process can be automatically restarted if a shoulder or MER deviation is detected (user configurable).

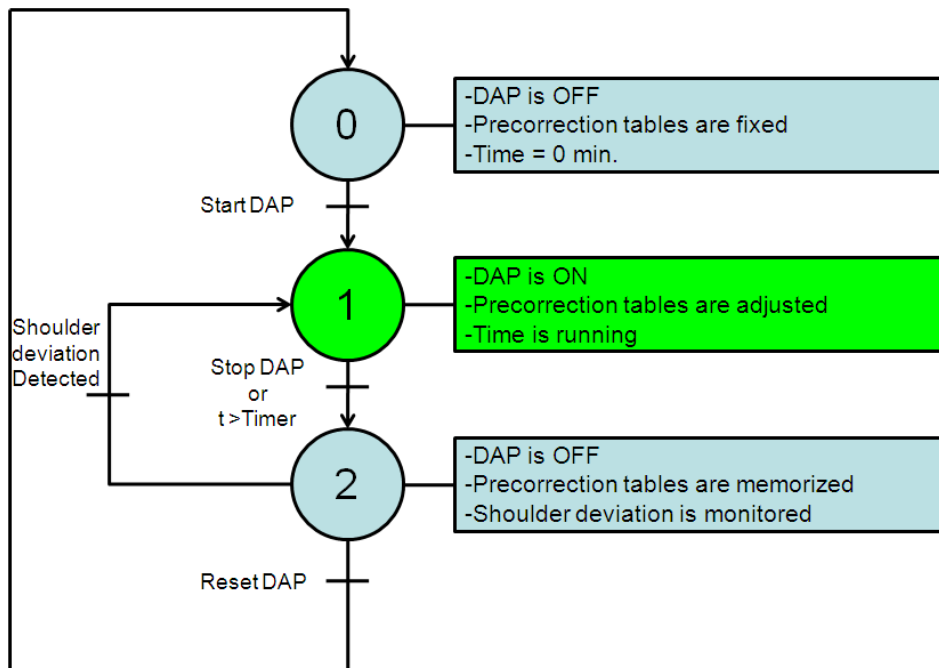
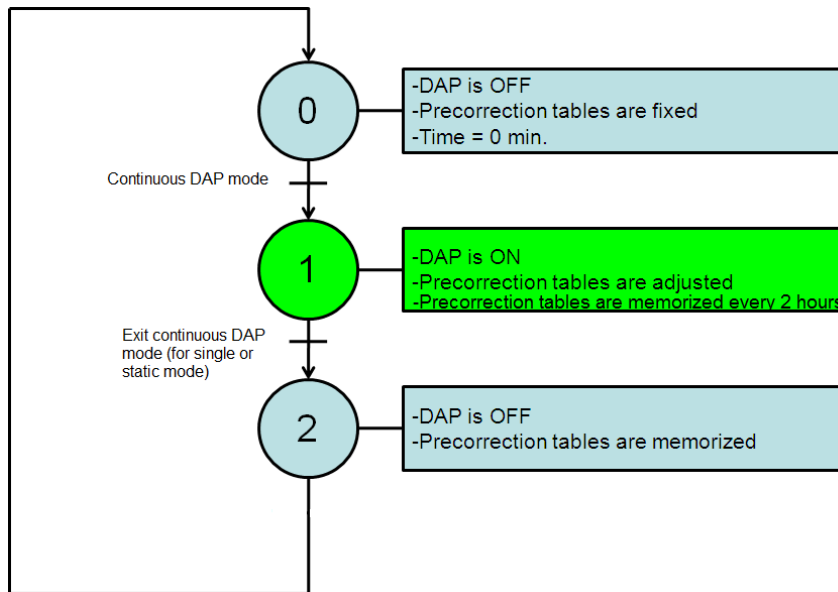

**Figure 8: Survey DAP mode operation**



**EXACT-V2 High End Rack Modulator / Exciter**

- **CONTINUOUS DAP:** The DAP works continuously until the user exits continuous mode.



**Figure 9: Continuous DAP mode operation**

**2.6.1.2 Linear Adaptive Precorrection**

The purpose of Linear precorrection is to correct the distortion in amplitude and in group delay of the output filter. The precorrector is based on a complex FIR filter which can correct up to 3dB (range -3dB to 3dB) in amplitude and up to 3µs (range 0 to 3µs) in group delay.

With the feedback after the output filter, an adaptive linear precorrection should automatically find the correct precorrection curve in a few minutes.

Two operating modes are possible:

- **STATIC (MANUAL EDIT) mode:** The DAP is disabled. The user can load a previous DAP configuration to be applied to the modulator or can edit the precorrection curves manually.
- **SINGLE mode:** The user starts the adaptive precorrection manually. The adaptive precorrection process is stopped if the timeout value has been reached or if the user stops the process manually.



## EXACT-V2 High End Rack Modulator / Exciter

### 2.6.2 Manual Digital Pre-correction

In addition to digital adaptive precorrection, EXACT-V2 also performs manual linear precorrection. Using the "MANUAL EDIT" mode, both amplitude and phase corrections are performed over the full spectrum of the signal.

For this purpose, a table of 32 points can be loaded in the modulator with the *Set Linear Curves* command. The table defines the amplitude and the phase precorrection that will be applied on the spectrum. For each point, a correction of  $\pm 3$  dB can be defined for the amplitude and  $\pm 500$  ns for the phase. The 32 points are equally spaced over the useful spectrum. The module itself then computes the correction to each carrier accordingly.

	6 MHz
Useful bandwidth	5.71 MHz
Frequency spacing between 2 consecutive points	184 KHz

**Table 2: Linear precorrection - frequency spacing**

**Note:** Using the *Set Linear Curves* command, the processing time required by the module (for computing the corresponding coefficients) can be long. It is therefore **recommended to use the busy flag** (available in *Get Linear Status* command) before any further module request, **or even better: the command *Set Linear Coefficients*** can be used instead in order to directly load the coefficients.

### 2.6.3 Adaptive Linear pre-correction for sharp channel filters (in ATSC 1.0)

With specific, sharp tuned filters, the EXACT-V2 Linear DAP algorithm could fail. Generally, the complexity of the channel filter is due to the fact that this filter is so tight. The compensation of such filtering requires a high level digital filter algorithm. The channel filter is so tight that DAP synchronization mechanisms cannot stay locked after a few iterations.

Hitachi-Comark has developed a dedicated method to improve the Linear precorrection for sharp filters. An additional digital filter process located after the original Linear DAP, known as the "Sharp Filter Profile" can be activated. This filter can be configured in the Web GUI in the "Settings/Precorrections" screen:

**EXACT-V2 High End Rack Modulator / Exciter**

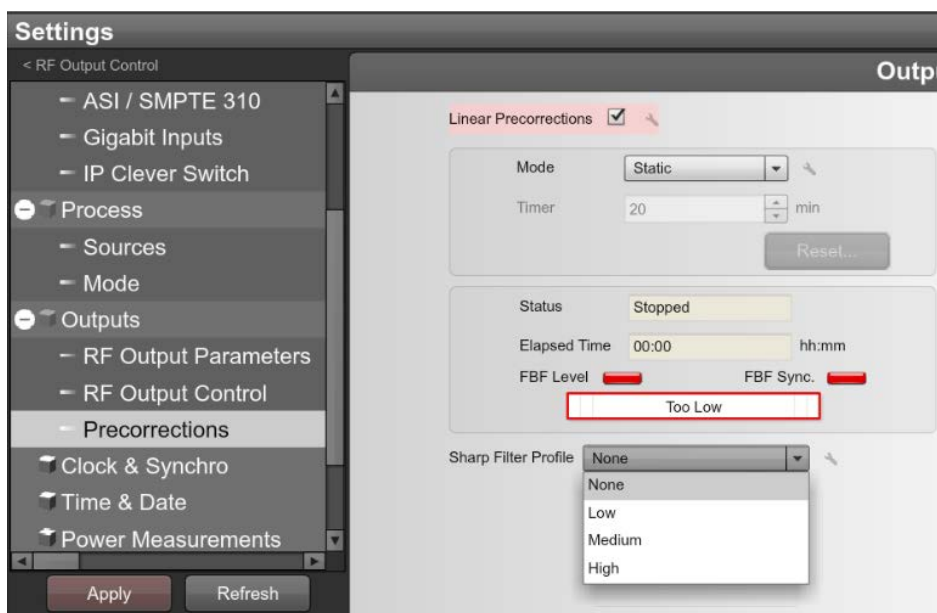

**Figure 10: Sharp Filter Profile menu**

**2.7 Output Processing**

The nominal output level of the main output "RF Out" is 0 dBm for the standard exciter and 20dBm for the exciter with optional preamp. An attenuation between 0 and 17 dB per increment of 0.1 dB can be set. In addition, an offset gain between -1 dB and + 1 dB per increment of 0.1 dB can be set. If needed, the output spectrum can be reversed. A copy of the main signal is available on the "RF Monitor". This output signal is the same as the main "RF Out" signal but with a lower level (-20dB for the 0dBm exciter, and -43dB for exciter with optional +20dBm internal preamp).

**2.7.1 RF output muting and RF maintain features**

The output can be muted either by the user or automatically in some conditions. The un-mute is pre-configured to "progressive" (2 seconds). The mute function is available for both ATSC standards.

Mute Mode	Mute cases & conditions in ATSC
Manually set	Manual Mute
	Starting Delay (after a boot)
Configurable mute conditions	Warm-up Time (before 10MHz regulation starts)
	Loss of Reference TimeOut (LORS) see <a href="#">LORS Management</a>

**Table 3: Mute cases and configurable mute conditions**

**RF Maintain feature:**

**EXACT-V2 High End Rack Modulator / Exciter**

The “RF Maintain” feature consists in keeping an RF signal presence out of the modulator in order to allow a constant power at the modulator RF output during an input stream error (the function “*RF Maintain on Input Stream Error*” shall then be enabled).

The overall objective is to avoid any RF signal interruption at the output of the modulator for protecting the amplifier.

When the “RF maintain” feature is selected, specific data is not broadcasted during the switching time from one input stream to another. A PRBS-like signal is used to maintain the original RF signal and RF power level. Thus the broadcasted signal cannot be decoded by any receiver.

**2.7.2 Crest Factor Reduction Management**

PAPR (Peak to Average Power Ratio) issues are associated with high power peaks present in the signal. By correctly managing PAPR reduction (Crest Factor reduction), the user will be able to avoid high power peaks from the modulator and so increase the output power level from the amplifier. It will then allow the best coverage for a given transmission site. However, this PAPR reduction feature will decrease MER performance as well as shoulder levels. It must be used carefully after studying the following explanations.

The PAPR solution uses two clipping modules for the best efficiency. Figure shows the location of the two modules as well as the user parameters.

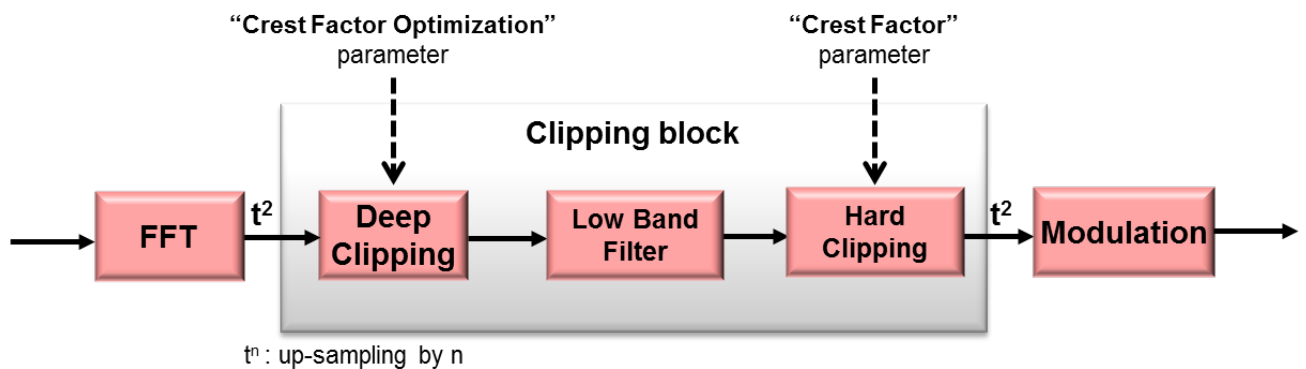

**Figure 11: PAPR block diagram**

**2.7.2.1 Crest Factor Parameter**

In order to reduce these peaks and avoid damage to the amplifier, the exciter uses a “crest factor” parameter. It is used to set the clipping level of the signal. The range is

**EXACT-V2 High End Rack Modulator / Exciter**

from 8dB to 20dB. The default value is 10 dB, meaning that a light crest factor reduction is performed.

The following figures display the Crest Factor parameter impact on a signal:

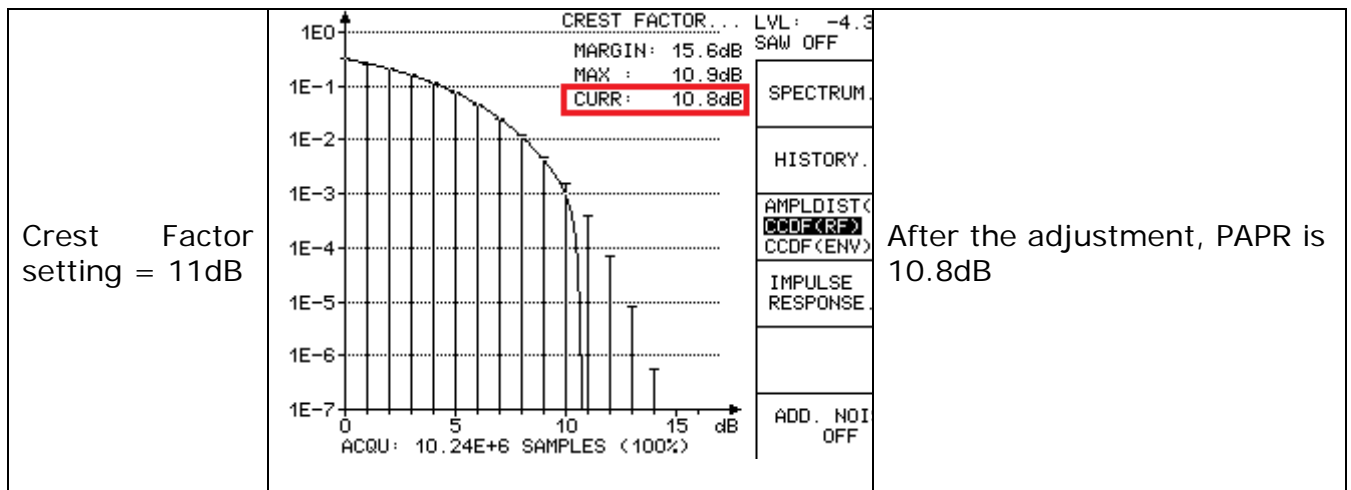
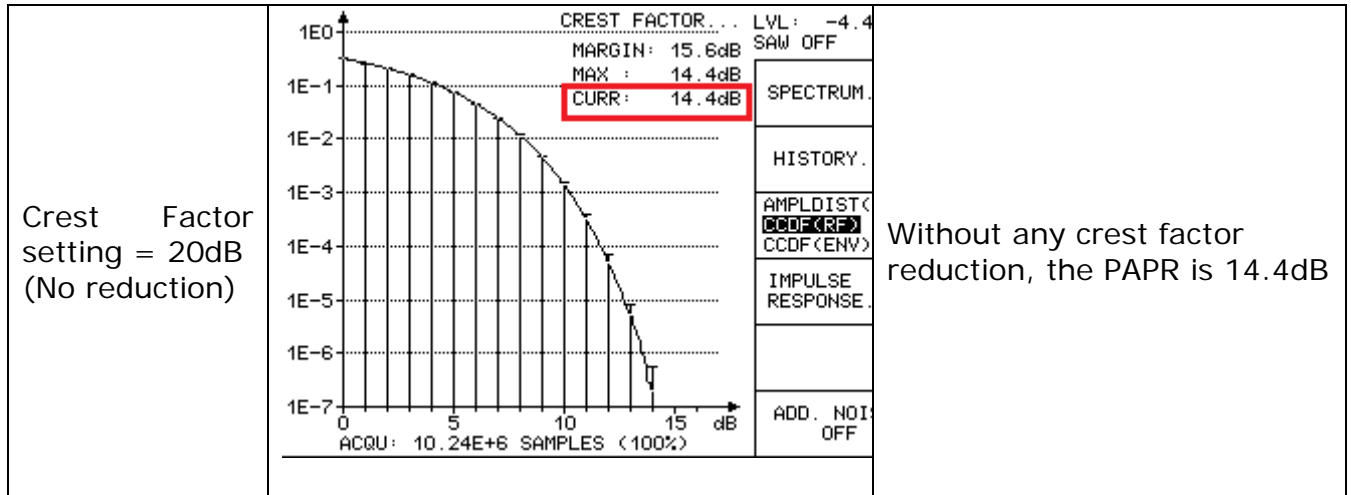

**Note:** In the screenshots above, the measurements are made using the <RF> value because the crest factor limit is fixed in the modulator using the RF value. Please note that some equipment may consider the <ENV> (Envelope) value, which is also commonly used and is about 3db less.

**EXACT-V2 High End Rack Modulator / Exciter**

**2.7.2.2 Crest Factor Optimization Parameter**

In order to allow the best amplifier efficiency a “Crest Factor Optimization” parameter has also been added. It is active when the crest factor reduction is enabled (value ≠ 0).

For a given “Crest Factor”, the “Crest Factor Optimization” enhances the signal shoulders. Finding the best value for this parameter allows the user to gain dB on the shoulders of the signal, thus optimizing the amplifier power.

This shoulder optimization involves a limited reduction in MER performance. That is why the user must find the best trade-off for the best efficiency.

This parameter can vary in a range from 0 to 255 (no unit). Figure shows the variation of the shoulder level and the MER for different parameter values at a given crest factor. When the Crest Factor Optimization parameter is increased, the shoulder level becomes better (from -33dBm to -50dBm). At the same time, the MER performance decreases (from 28dB to 15dB). As explained earlier, a trade-off between the two is necessary to obtain the best overall optimization.

In addition, due to curve shape we see there is an ideal range for the Crest Factor Optimization parameter of about 70 to 150. In this range the variation of both shoulder level and MER are significant. Out of this range the loss of MER is too severe for little or no shoulder level gain. For instance, for a Crest Factor Optimization of 120, we observe a gain of 10dB for the shoulder level and a loss of only 3dB for the MER.

Hitachi-Comark therefore recommends that this parameter be set in the ideal range of 70 to 150.

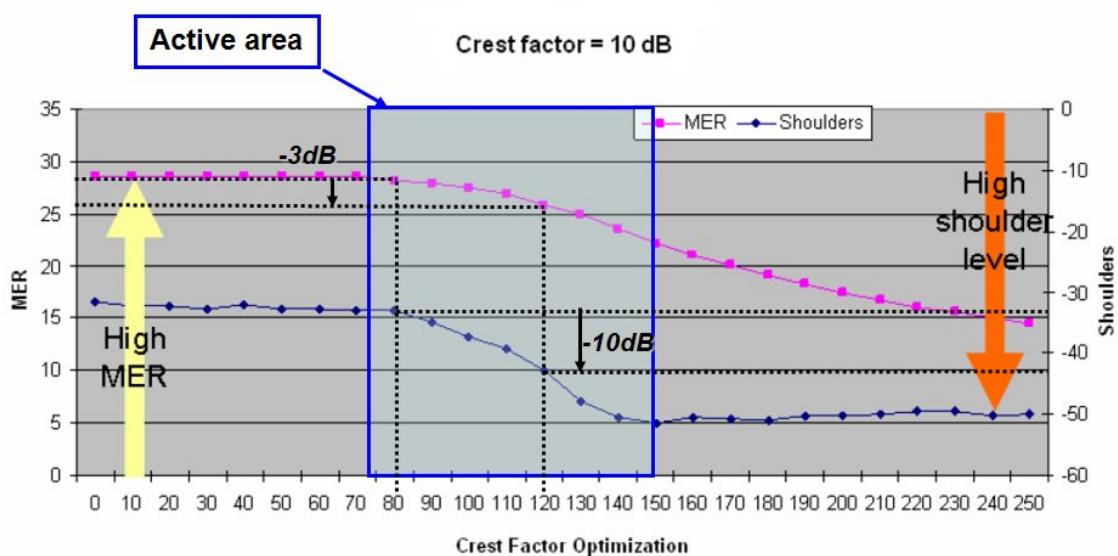

**Figure 12: Crest Factor Optimization Impact**

## EXACT-V2 High End Rack Modulator / Exciter

### 2.7.2.3 Protection Clipping Parameter

Since adaptive precorrection can produce power peaks at the modulator output, a “protection clipping” has been added at the output of the modulator. It will allow the user to protect the amplifier input by clipping the signal out from the modulator.

**Note:** Protection Clipping = 20 means OFF  
Recommended value to start = 15dB (default value)

### 2.7.3 DAP Operation

DAP stands for “Digital Adaptive Precorrection”, it is an option allowing the user to run the EXACT-V2 in a very high-end mode in order to reach unequalled RF signal performance and to allow a significant gain in transmitter Power Efficiency.

#### ✓ License activation

First, the use of the DAP mode requires the user to unlock the “DAP” license key. This can be done in the *Settings* Tab under *Management > Options*

The screenshot displays the web interface for the EXACT-V2 High End Rack Modulator / Exciter. The top navigation bar includes the COMARK logo, the title "EXACT - ATSC", and user controls like "Administrator", "Log out", "Refresh Settings", "Refresh", and "Refresh Monitoring". The main content area is titled "Settings" and shows the "Management - Options" configuration page. A left-hand navigation menu lists various settings categories: Management (General, Options, Files), Inputs, Process, Outputs, Clock & Synchro, Time & Date, Power Measurements, Redundancy, and Transmitter. The "Options" section is expanded, showing a list of parameters: TSolP (Locked), GAP (Unlocked), AGC (Unlocked), REDUNDANCY (Locked), and SNMP (Locked). Each parameter has a corresponding "Unlock..." button. A red arrow points to the "Unlocked" status of the GAP parameter. Below the Options section is the "Standards" section, which includes ATSC 1.0 (Enabled) and ATSC 3.0p (Disabled) with an "Enable..." button. At the bottom of the interface is a "Monitoring" dashboard with five panels: Management (Input, Output, Alarm status), Inputs (ASI 1, ASI 2 status), Process (status), Outputs (RF Output, Stream, FWP, RFP, RFP Status status), and Clock & Synchro (Clock Synchro status). A "Refresh" button is located at the bottom left of the settings area.

**EXACT-V2 High End Rack Modulator / Exciter**

✓ DAP mode activation

In the *Settings* Tab, the DAP mode can be enabled under *Outputs > Precorrections*:



**Note:** Enabling or disabling the *DAP* causes a reset of the non-linear curves. The user is then given the possibility to save the current curves, if needed.

✓ Non-Linear DAP launch

The same protocol as the basic DAP applies (please refer to the previous chapter).



## EXACT-V2 High End Rack Modulator / Exciter

### 2.8 Clock and Synchronization

The clock and synchronization function is responsible for synthesizing the required temporal signals and data rates. A high-stability 10 MHz OCXO provides the internal clock reference.

However, if synchronization with other equipment is required, an external 10 MHz clock signal can be chosen as a reference together with external 1PPS. The user shall configure the signal reference edge (rising or falling edge). An internal 1 PPS signal is generated from the external signal in order to maintain synchronized the output signal as long as possible in case of external signal failure.

The modulator clock reference (10MHz) source can be configured as:

- Locked on the external 10 MHz signal reference (by default),
- Derived from the 1PPS source (either on-board GPS or external 1PPS)
- Internal.

The module delivers a 10 MHz clock reference output signal and can also provide 1PPS if the user configures the "1PPS IN/OUT" connector as an output. For VX20-x0x2 (with on-board GPS), the 1PPS output is derived from the on-board GPS.

#### 2.8.1 GPS and clock management for VX20-x0x2

For VX20-x0x2, the on-board GPS block gives the possibility to directly receive an incoming GPS or Glonass signal. Please refer to [Appendix C](#) for GPS installation recommendations and [Appendix D](#) for GPS antenna recommendations.

Up to four satellite signal levels may be displayed (Note: In case of GPS/Glonass, the four strongest levels are chosen amongst the eight total signals available.) Signal level is normally positive. If it is zero, this means that no satellite lock has been acquired yet. If it is negative, then that satellite is not being locked. The absolute value of a signal level field is the last known signal level of that satellite.

**Note:** The GPS configuration parameters (location & time) is kept in the memory for faster synchronization after reset or ON/OFF.



**EXACT-V2 High End Rack Modulator / Exciter**

The figure below shows the entire VX20-x0x2 synchronization processing block (the on-board GPS being depicted as "GPS receiver"):

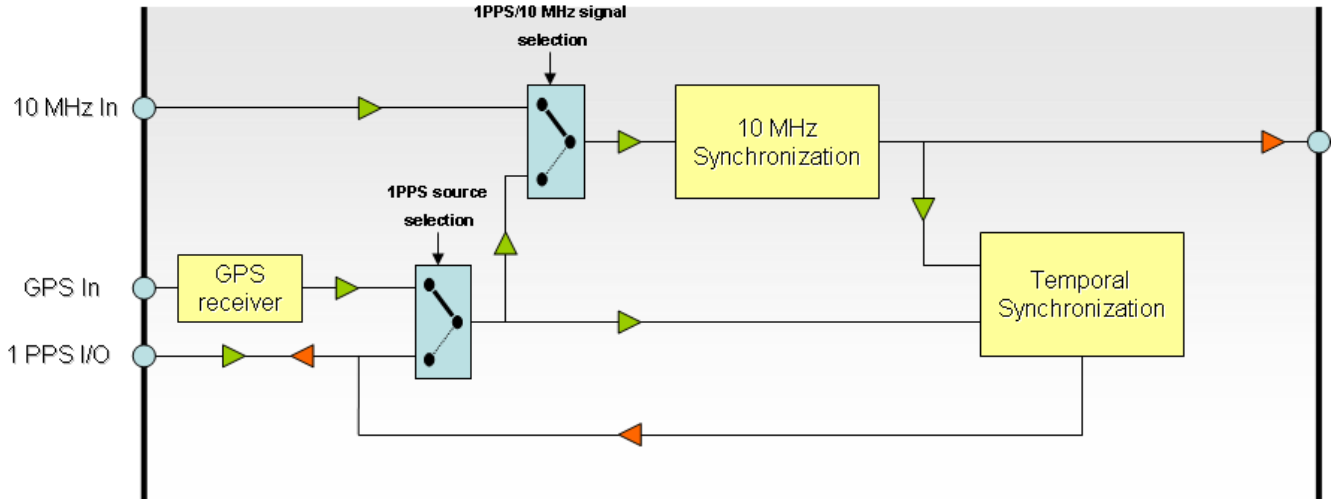

**Figure 13: VX20-x0x2 synchronization processing block**

Then, depending on the user's setup, three cases can be considered:

1) Working with external GPS signal reference (using on-board GPS receiver):

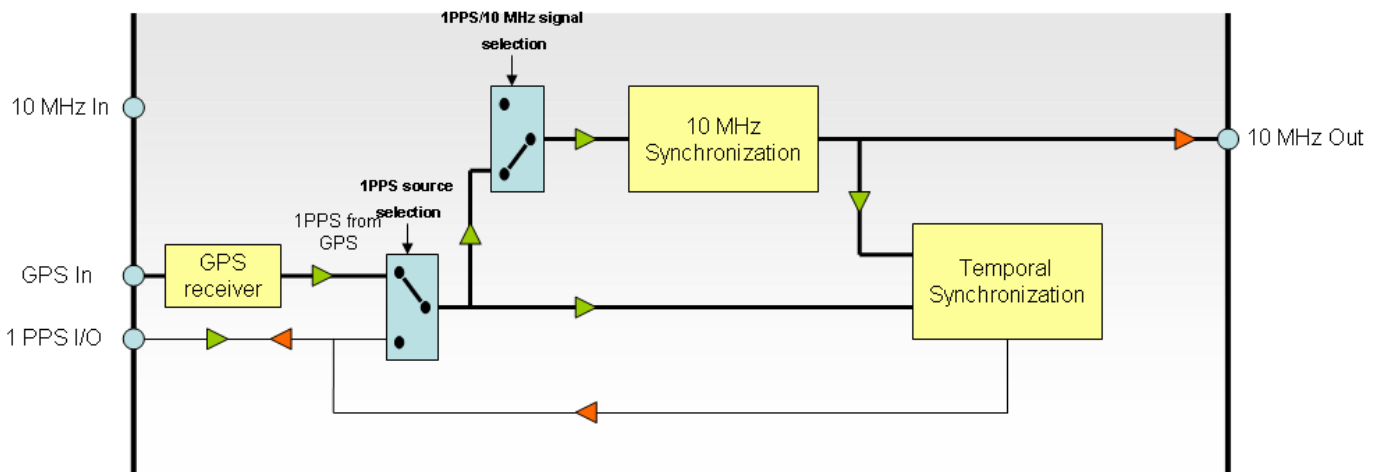
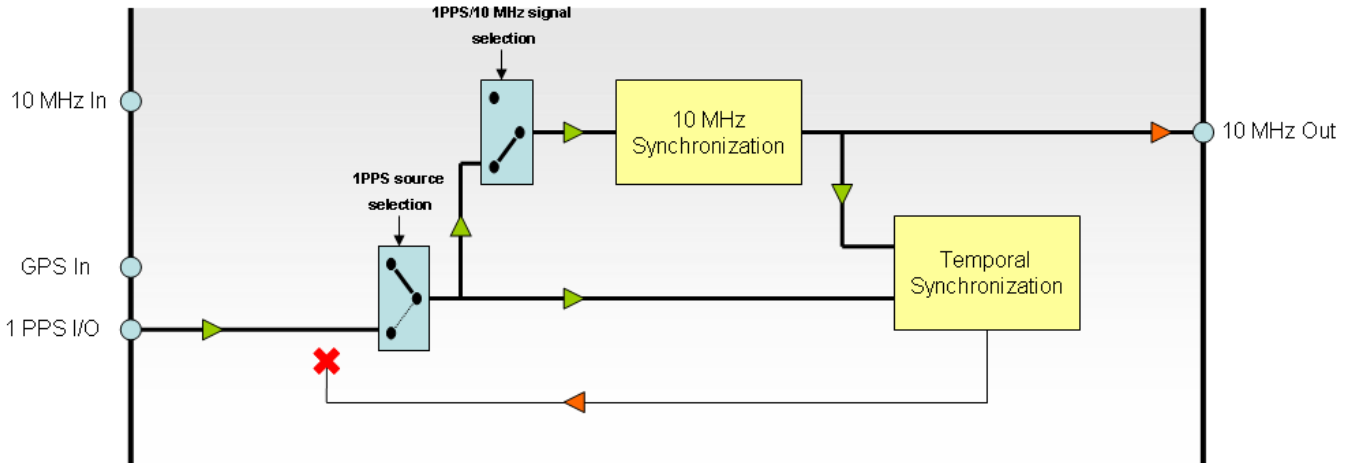

**Figure 14: VX20-x0x2 clock synchronization - GPS signal**

In this case, the modulator processes the 1PPS due to the on-board GPS receiver. The GPS reference signal is available on GPS In interface. This 1PPS reference signal is used both for temporal synchronization and 10 MHz PLL locking. The 1 PPS I/O can be configured as an output to provide a 1PPS signal to other equipment.

**EXACT-V2 High End Rack Modulator / Exciter**

2) Working with external 1PPS reference signal:



**Figure 15: VX20-x0x2 clock synchronization – external 1PPS signal**

In this case, the modulator directly uses the 1PPS available from the external source available on the 1PPS I/O interface. This 1PPS reference signal is used for both temporal synchronization and 10 MHz PLL locking.

3) Working with external 10 MHz and external 1PPS reference:

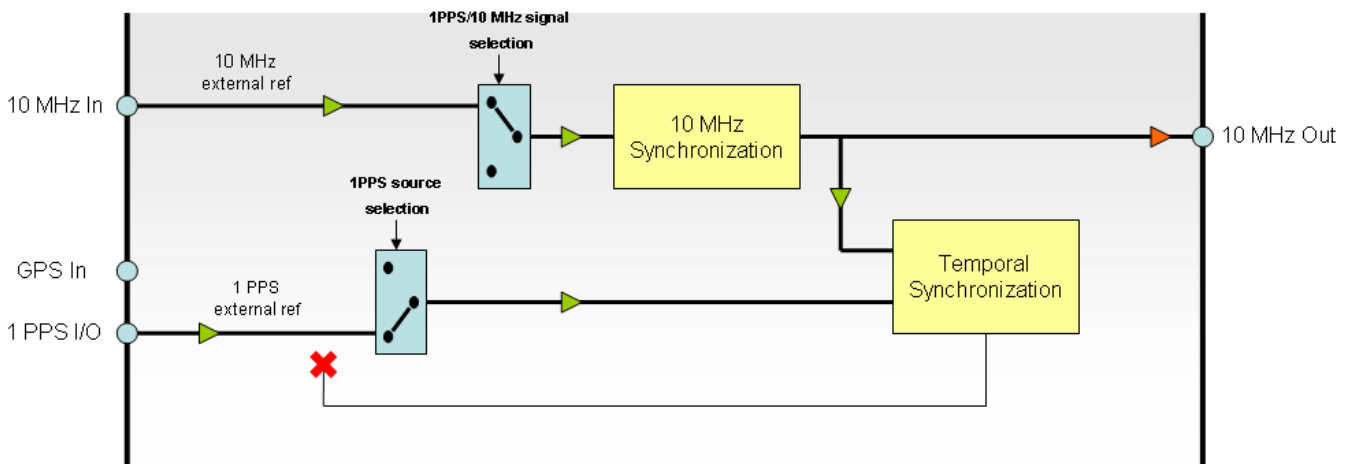

**Figure 16: VX20-x0x2 clock synchronization – external 10 MHz and 1PPS signal**

In this case, the modulator uses the external 10 MHz signal as well as the external 1PPS signal available on the 10 MHz In and 1PPS I/O interfaces, respectively.

A 10 MHz reference signal is always available on the 10 MHz Out interface.

## EXACT-V2 High End Rack Modulator / Exciter

### 2.8.2 Warm-up Time

This part aims at describing the WARM-UP function which has been designed for compensating the start-up delay of the OCXO (for instance, in case of AC power loss). In order to be stable the internal temperature of the OCXO must be stabilized and equal to 85°C. However, this could take up to 5 minutes to obtain a stable 10MHz reference.

During this unstable situation, the OCXO response is not linear and the 10MHz regulation algorithm takes a long time to converge. The WARM-UP survey has been defined for optimizing the 10MHz behaviour during that time.

If it is enabled, the WARM-UP function is a new state of the 10MHz regulation, during which it is deactivated until the external reference is stable again. The 10 MHz regulation then starts again after that state is finished.

This WARM-UP time typically takes 3-4 minutes and is limited to 10 minutes in any case.

### 2.8.3 Loss of Reference Signal management (LORS)

**Note:** LORS is not useful when operating in MFN-Standalone configuration and shall be considered ad reserved for Future Use (RFU).

In SFN, an accurate clock synchronization is very critical for ensuring a good SFN operation. For this purpose, the module implements the following operating modes in case of loss of the synchronization signal reference(s) (LORS). When losing temporal synchronization, it can be set to automatically mute after a variable delay (Time Out counter) also set by the user, from 0 (immediate mute) to 1440 min (24 hours), by 1 minute steps.

In the table below, it is assumed that the primary clock is 10MHz and the secondary clock is 1 PPS:

10 MHz	1 PPS	Operating Mode	Status
Detected	Detected	Normal	No alarm
Detected	Loss of Signal	Clock_source= External 10MHz	External 1 PPS warning
Loss of Signal	Detected	Clock_source= External 1PPS	External 10 MHz warning
Loss of Signal	Loss of Signal	Clock_source= Internal (Configurable Mute after LORS TimeOut)	External 1 PPS & 10 MHz critical alarms.
Unlocked PLL	-	Configurable Mute on SFN Not Ready	PLL_ Unlocked status = SFN not ready

**Table 4: LORS management table**

## EXACT-V2 High End Rack Modulator / Exciter

The PLL\_Unlocked status (*Mute on SFN Not Ready*) is used in order to maintain that the output signal is muted (please refer to the mute conditions in chapter *RF output muting and RF maintain features*.)

In case of SFN application, an optional functionality “PPS auto resync” is available to allow resynchronization of the internal PPS (used as a reference time in SFN) when 10MHz clock control is locked. This optional functionality allows having the best accuracy on time reference PPS used for SFN systems.

The external references have to follow the recommendations specified in the interface description § Interfaces characteristics. The switching is seamless from external reference signal to the 10 MHz internal clock.

Note: In case both Mute conditions “Mute on LORS” and “Mute on Clock Not Synchro” (or “Mute on SFN Not Ready”) are enabled, the Mute will occur only after the LORS TimeOut has ended, as shown in the chronograms below:

1. Mute behaviour when:
  - ✓ Mute on LORS is enabled
  - ✓ Mute on Clock Not Synchro is enabled
  - ✓ LORS TimeOut is reached

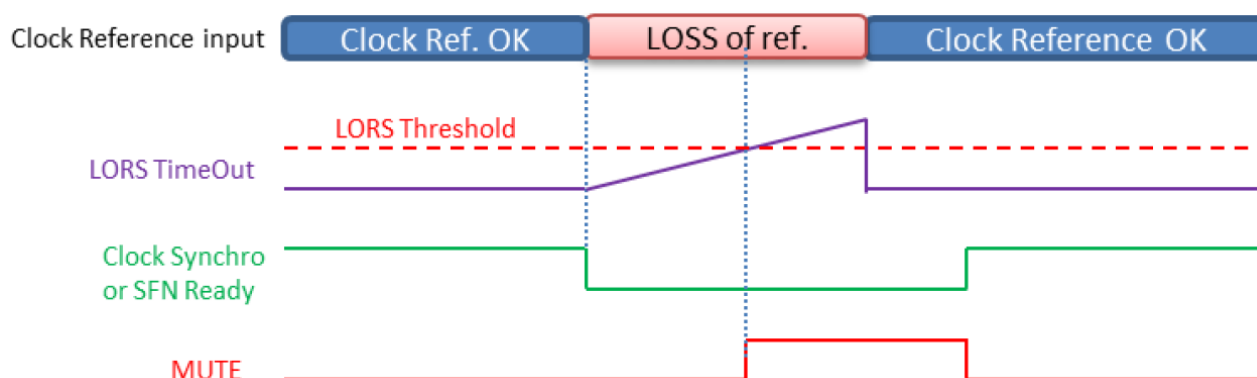
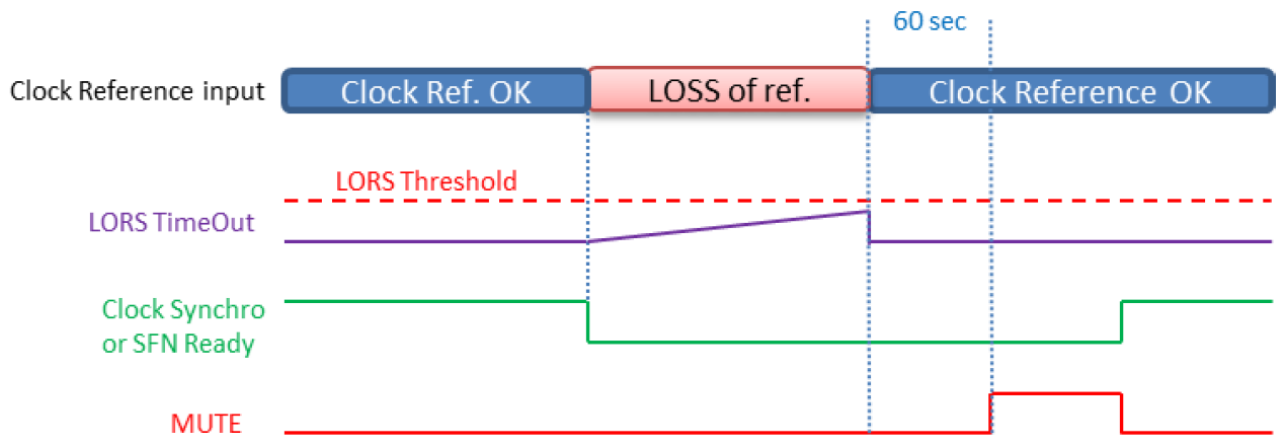

Figure 17: Mute behaviour – LORS TimeOut is reached

**EXACT-V2 High End Rack Modulator / Exciter**

2. Mute behavior when:
- ✓ Mute on LORS is enabled
  - ✓ Mute on Clock Not Synchro is enabled
  - ✓ LORS TimeOut is not reached

If the LORS TimeOut is not reached when the clock reference comes back, another timeout starts (fixed to 60 sec), after which the module will mute if the Clock Synchro is still not OK:



**Figure 18: Mute behavior – LORS TimeOut is not reached**

**2.9 Power Measurements**

EXACT-V2 provides the capability to measure the forwarded and reflected RF power output from the transmitter, as described in the following figure.

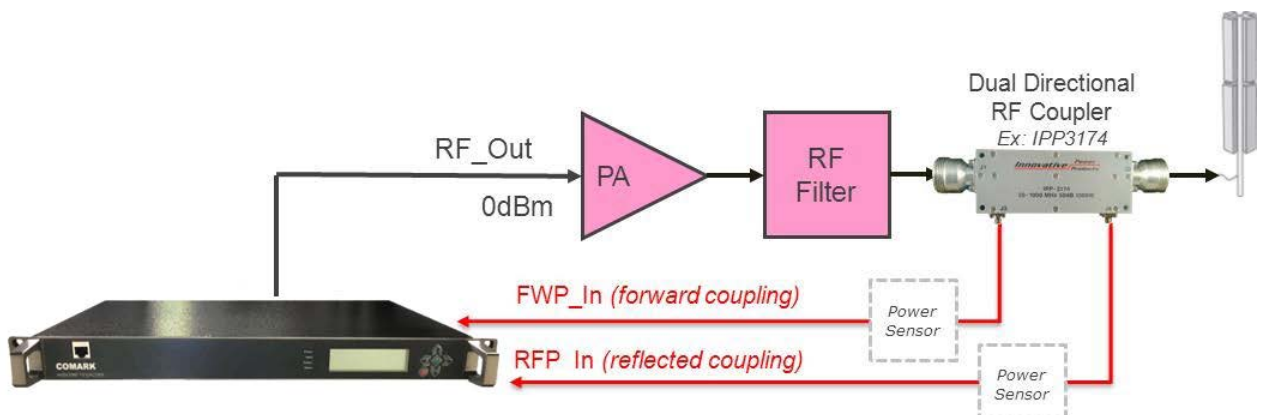

**Figure 19: Power measurement**

Using an RF coupler, the user will connect the output of the transmitter to both FWP\_In and RFP\_In dedicated inputs.

Each input is able to receive:

- An RF signal from 0 to -20dBm ( $\pm 0.5$ dBm accuracy from 0 to -10dBm,  $\pm 1$ dBm accuracy from 0 to -10dBm)

## EXACT-V2 High End Rack Modulator / Exciter

- A VDC signal from an external power sensor from 0 to 5VDC

The working mode is configurable using the WEB GUI.

Depending on the mode selected, additional parameters will be needed, such as the coupler sample value or external sensor offset/slope factor, to ensure an accurate measurement. Please refer to your external device user manual.

Minimum and maximum warning and alarm thresholds for both forward and reflected power can be set via WEB GUI by the user for error management and monitoring.

### 2.10 Automatic Gain Control (AGC)

EXACT-V2 provides a built-in output AGC to drive power amplifier stage. The output allows the device to maintain a very stable system output power that could otherwise vary depending on temperature, aging, etc.

This feature uses the previously described FWP-In input. The maximum gain can be configured (depending on the initial EXACT-V2 output power and the maximum EXACT-V2 output power) by the user to protect the PA input stage from power peaks.

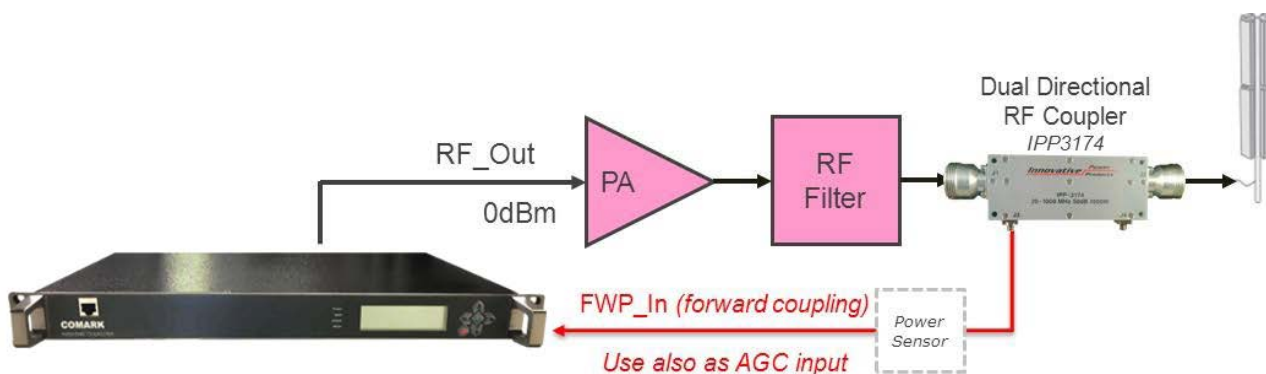

Figure 20: Built-in output AGC

**EXACT-V2 High End Rack Modulator / Exciter**

---

**3**

**EXACT-V2 Rack**

---

**EXACT-V2 High End Rack Modulator / Exciter**



## EXACT-V2 High End Rack Modulator / Exciter

The EXACT-V2 unit is a standard 1RU rackmount chassis. The dimensions are 9.8" x 19" x 1.75". The modulator weight is 10 lbs.



Figure 21: EXACT-V2 1RU

### 3.1 EXACT-V2 mechanics

#### 3.1.1 Front panel layout

Below is a depiction of the exciter's front panel.



Figure 22: Front panel overview

The front panel is composed of an LCD screen display with six buttons: four navigation buttons (up, down, left and right arrows), one "OK" green button and one "Cancel/Return" red button.

This front panel display allows the user to monitor and control the main features of the EXACT-V2 exciter. Advanced features need to be accessed via the Web GUI.

Four status LEDs are also available: Power, Input, Output and Alarm. For a detailed description, refer to paragraph 3.3 "Front Panel signalization (LEDs description)".

**EXACT-V2 High End Rack Modulator / Exciter**

A Control Ethernet port is also available on the front panel.

**3.1.2 Rear Panel Layout**

Below is a depiction of the exciter’s rear panel.



**Figure 23: EXACT-V2 Rear panel overview**

The rear panel provides all the connectors needed for interconnection with the exciter. Please refer to the next section for a detailed description.

**3.2 Interface characteristics**

The product interface are as follows:

Stream input interfaces		x 2
General	Function: Standard: Name: Connector: Type:	Primary & secondary Inputs SMPTE-310M & DVB-ASI ASI/SMPTE_IN1 & ASI/SMPTE_IN2 BNC Connector– Input impedance 75Ω Input
Performance	Data Rate: Mode: Format:	DVB-ASI: 80 Mbps maxi. SMPTE-310M: 19 Mbps Burst or Packet mode (DVB-ASI) DVB-ASI: 188/204 bytes SMPTE-310M: 188 bytes



**Figure 24 ASI/SMPTE-310M Input interfaces**

**EXACT-V2 High End Rack Modulator / Exciter**

**ASI Stream Output interface x 1**

General	Function:	ASI Output
	Standard:	DVB-ASI
	Name:	ASI_Out
	Connector:	BNC Connector-impedance 75Ω
	Type:	Output
Performances	Data Rate:	ASI: 80 Mbps maxi.
	Mode/Format (Out):	Packet mode/188-byte



**Figure 25: ASI Output interface**

**Electrical Gigabit Port (Data & Control) x 2**

General	Function:	Gigabit Ethernet Port
	Standards:	Ethernet, IP
	Connector Name:	Gigabit1/Ctrl & Gigabit2
	Connector Type:	RJ-45
	Type:	Input/output
Performances	Data Rate:	1 Gbps max
	Ethernet:	10/100/1000 Base T
	Packet Type:	IPv4 – IPV6 Ready
	Protocols:	IEEE802.3, IPv4, IPv6, XML, FTP, SNTP
	Jitter Tolerance:	50 ms
	Mode:	Half/full duplex
	Stream Encapsulation:	Accept IP and ALP formats (ATSC3.0)
	FEC Decoding	SMPTE-2022 [17 & 18]



**Figure 26: Electrical Gigabit Data Interfaces**



**Figure 27: Electrical Gigabit Control Interfaces**

**EXACT-V2 High End Rack Modulator / Exciter**

GPS Antenna input		x1
General	Function: Name: Connector: Type:	GPS antenna input GPS SMA Input
Performances	Antenna Type:	Active
	Antenna Voltage	3.3 VDC
	Antenna System Gain:	10 dB
	Frequency	1575.42 MHz



Figure 28: GPS antenna input

Clock reference input		x 1
General	Function: Name: Connector: Type:	Frequency reference input 10 MHz_IN BNC – 50 Ω Input
Performances	Frequency: Level:	10 MHz From -15 to +15 dBm



Figure 29: Clock reference input

Clock reference Output		x 1
General	Function: Name: Connector: Type:	10 MHz reference output 10 MHz_OUT BNC – 50 Ω Output
Performances	Frequency: Level:	10 MHz 0 dBm ± 3 dB



Figure 302: Clock reference output

**EXACT-V2 High End Rack Modulator / Exciter**

1PPS reference input/output		x 1
General	Function: Name: Connector: Type:	Time Reference in/out 1PPS BNC – 50 kΩ Configurable I/O
Performances	Signal : Level:	1 PPS LVTTL / TTL (input) LVTTL (output) ±50ns (input tolerance)



Figure 31: 1PPS reference input/output

RF Output		x 1
General	Function: Standards: Name: Connector: Type:	RF output ATSC 1.0 & ATSC 3.0 RF N connector – 50 Ω Output
Performances	Frequency*:  Bandwidth: Level:  <u>ATSC 1.0:</u> EVM: Shoulders: Spurious:  <u>ATSC 3.0:</u> MER: Shoulder: Spurious:	VHF (54-88 MHz) VHF (170-216 MHz) UHF (470-862 MHz) 6 MHz 0 dBm  < 2.5% equalizer off 57 dB / 63 dB with precor ≤ -50dBc  ≥ 40dB ≥ 40dB ≤ -50dBc

\*Specify UHF, VHF, or VHFB3 at time of order.



**EXACT-V2 High End Rack Modulator / Exciter**

RF Output (with OPT-20dB Internal Preamp)		x 1
General	<b>Function:</b> RF output <b>Standards:</b> ATSC 1.0 & ATSC 3.0 <b>Name:</b> RF <b>Connector:</b> N connector – 50 Ω <b>Type:</b> Output	
Performances	<b>Frequency*:</b> VHF (54-88 MHz) VHF (170-216 MHz) UHF (470-862 MHz)  <b>Bandwidth:</b> 6 MHz <b>Level:</b> +20 dBm  <u>ATSC 1.0:</u> <b>EVM:</b> ≤ 2.5% equalizer off <b>Shoulders:</b> 57 dB / 63 dB with precor <b>Spurious:</b> ≤ -50dBc  <u>ATSC 3.0:</u> <b>MER:</b> ≥ 40dB <b>Shoulder:</b> ≥ 40dB <b>Spurious:</b> ≤ -50dBc	

\*Specify UHF, VHF, or VHFB3 at time of order.



**Figure 32: RF output**

**EXACT-V2 High End Rack Modulator / Exciter**

<b>Monitoring Output</b>		<b>x 1</b>
General	Function: Standards: Name: Connector: Type:	Monitoring output ATSC Monit Out SMA – 50 Ω Output
Performances	Frequency: Level: Other:	See RF Output -20 dB (relative to RFout)
<b>Monitoring Output (with OPT-20dB internal preamplifier)</b>		<b>x 1</b>
General	Function: Standards: Name: Connector: Type:	Monitoring output ATSC 1.0 / ATSC 3.0 Monit Out SMA – 50 Ω Output
Performances	Frequency: Level: Other:	See RF Output -43 dB (relative to RFout) Monitoring signal from modulator board (before amplifier)



**Figure 33: Monitoring output**

**EXACT-V2 High End Rack Modulator / Exciter**

<b>RF Feedback Inputs</b>		<b>x 2</b>
General	Function: Standards: Name: Connector: Type:	RF Feedback inputs / RF Measurements - FBA / FBF SMA – 50 Ω Input
Performances	Frequency: Bandwidth: Level: Max input level: Return loss:	UHF, VHF or VHF B3 depending on model 75 MHz -5 to -15 dBm +5dBm (before damage) >13dB



**Figure 34: Feedback inputs**

<b>Forward Power Measure Input/AGC</b>		<b>x 1</b>
General	Function: Standards: Name: Connector: Type:	Forward Power Measure - FWP In SMA – 50 Ω / High impedance Input
Performances (RF input)	Frequency: Range: Precision: Max input level: Return loss: Impedance:	Depends on model 0 to -20dBm Typical 0 to -10dBm 0.5dB typical +5dBm (before damage) >12dB 50 Ω
Performances (VDC input)	Range: Precision: Impedance:	0 to 5VDC 0.01VDC typical 80 KΩ



**Figure 35: Forward Power Measurement / AGC input**



**EXACT-V2 High End Rack Modulator / Exciter**

Reflected Power Measure Input		x 1
General	Function: Standards: Name: Connector: Type:	Reflected Power Measure - RFP In SMA – 50 Ω / High impedance Input
Performances (RF input)	Frequency: Range: Precision: Max Input Level: Return Loss: Impedance:	Depends on model 0 to -10dBm 0.5dB typical +5dBm (before damage) >12dB 50 Ω
Performances (VDC input)	Range: Precision: Impedance:	0 to 5VDC 0.01VDC typical 80 KΩ



**Figure 36: Reflected Power Measurement input**

**EXACT-V2 High End Rack Modulator / Exciter**

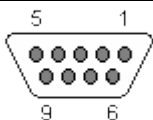
TOD		x 1
General	Function: Standards: Name: Connector: Type:	Control / monitoring 1x RS-232 Serial Port 1 Female SubD9 RS-232/RS-485
Performances	Control Baud rate: TOD Baud rate: Other:	9600 bps to 115200 bps 9600 bps No parity, 8 bits data, 1 bit stop
		
PIN	Name	Dir
1	RS232 Tx	Out
2	Rfu	
3	TOD Rx	In
4	RS232 Rx	In
5	GND	
6	RS485 Rx+	In
7	RS485 Rx-	In
8	RS485 Tx+	Out
9	RS485 Tx-	Out
Shield	GND	



**Figure 37: TOD/RS232 Port**

The information containing Time Of Day (TOD) is available on Tekelec GPS with the following characteristics:

- ASCII, 9600 bps, 8bits, 1 stop bit, no parity
- Protocole <message> <CR> <LF>
- Format day/year hour:minute:seconds e.g. 317/1996\_18:16:20

The content of message should read "GPS reference" and not "UTC reference" or "local time".

**EXACT-V2 High End Rack Modulator / Exciter**

Alarm <span style="float: right;">x 2</span>		
General	Function:	Alarm relays
	Name:	GPIO / GPIO2
	Connector:	SubD9 connectors
	Type:	Dry contacts / GPI / VDC <sub>in</sub> / VDC <sub>out</sub>

PIN	Name	Dir
1	RELAY1_Normally_Open (Open when active alarm)	
2	12 VDC output through 2.7 Kohms resistor and protection diode	
3	RELAY2_COM	
4	RELAY3_Normally_Open (Open when active alarm)	
5	GND (cathode of the opto-coupler diode)	
6	RELAY1_COM	
7	RELAY2_Normally_Open (Open when active alarm)	
8	Anode of the opto-coupler diode through 330 ohms resistor	
9	RELAY3_COM	
Shield	GND	

PIN	Name	Dir
1	RELAY4_Normally_Open (Open when active alarm)	
2	12 VDC output through 2.7 Kohms resistor and protection diode	
3	RELAY5_COM	
4	RFU	
5	GND (cathode of the opto-coupler diode)	
6	RELAY4_COM	
7	RELAY5_Normally_Open (Open when active alarm)	
8	Anode of the opto-coupler diode through 330 ohms resistor	
9	RFU	
Shield	GND	



**Figure 38 : Alarms Port**

**EXACT-V2 High End Rack Modulator / Exciter**

**3.3 Front Panel signalization (LEDs description)**

A set of 4 LED's indicate the exciter status:

- o A Power LED indicator
- o An Input LED indicator
- o An Output LED indicator
- o An Alarm LED indicator

Behavior may differ depending on the exciter function and configuration.

Below is a description of the LED's behavior:

Name	Description
Power	Green off: power off Green static: power on
Input	Green off: Primary input is not detected (in manual mode) or primary and secondary input is not detected (in auto mode) Green flashing: Primary input is OK <sup>(1)</sup> but secondary input is OK (in auto mode) Green static: Primary input is OK <sup>(1)(4)</sup>
Output	Green off: no RF output (module failure or mute condition) Green static: the RF output is available (normal mode) Green flashing: Test signal <sup>(2)</sup> is generated or RF Maintain mode Yellow static: Warning RFP or FWP Red static: Error RFP or FWP Red flashing : RFP Critical Error
Alarm	Off: No critical error detected Red static: Module failure Red flashing: Primary input failure <sup>(3)</sup> or primary clock reference <sup>(5)</sup> loss (10 MHz or PPS in case of ext 10MHz + ext 1PPS primary selection)

**Table 5: LED status**

- (1) If primary input is detected while any condition for "Mute on TS error" is met, the input LED flashes.
- (2) PRBS, Sine, or any special test.
- (3) Except in case of PRBS or Sine test mode.
- (4) In automatic mode, if primary input is detected, the input LED is fixed whatever the secondary input status.

**EXACT-V2 High End Rack Modulator / Exciter**

**3.4 Power requirements**

The exciter must be powered by a 110-240VAC 50-60Hz voltage.

The overall EXACT-V2 modulator consumes up to 70 W.

The overall EXACT-V2 exciter consumes up to 120 W with optional +20 dB preamp.



**Figure 39: Power supply plug**

A yellow/green ground cable (0.75mm<sup>2</sup> min) must be connected to the small connector located between the power supply plug and the GPS antenna input. This cable must be securely connected to the ground before switching on the equipment.

**3.5 Performances and technical characteristics**

**3.5.1 General characteristics**

Characteristics	Typical Value	Comment
<b>Environment</b>		
Power Voltage: Frequency Range: Power Consumption:	90 - 264 VAC 50-60 Hz < 70 W <120 W	EXACT-V2 EXACT-V2-20dB
Dimensions:	9.8" x 19" x 1.75"	
Weight:	10 lbs	
Operating Temperature:	0 °C to +50 °C	
Storage Temperature:	-10 °C to +70 °C	
Storage Relative Humidity:	10 to 80 % at 50 °C	
Operating altitude:	≤ 2000m	
Cleaning:	Air cooling areas	

**3.5.2 Control and data Ethernet interfaces**

Gigabit interfaces	Typical Value	Comment
<b>Ethernet</b>		
Control Link & :	10/100/1000 Base-T Half / Full duplex	

## EXACT-V2 High End Rack Modulator / Exciter

Data Link	Auto nego	
<b>IP Characteristics</b>		
Maximum Bit Rate:	100 Mbps	
Number of Processed IP Streams:	1 per physical interface	
Maxi Network Jitter Tolerance:	50 ms	
Ethernet MTU Length:	Max 1500 bytes	In ATSC 1.0
<b>Data De-Encapsulation</b>		
Protocol:	TS / RTP / UDP / IP and Pro-MPEG Cope 3 decoding (compliant with SMPTE 2022-1-2007 and SMPTE 2022-2-2007)	
TS Packet Number per IP Packet:	1 to 7	User configurable
FEC Decoding:	SMPTE 2022	
FEC Type:	SMPTE 2022	
FEC Matrix (L,D)/(LxD) :	SMPTE 2022	
MPEG-TS Packet Length:	188 bytes	

### 3.5.3 Serial control interfaces

Control interfaces	Typical Value	Comment
<b>RS232</b>		
Standard:	RS232	TX and RX signals only. Limited to the use for "TX control" part (does not fully control the exciter)
Electrical Level:	±12v compatible	
Baud Rate:	9600 bauds to 115200 bauds	
Others:	No parity, 8 bits data, 1 bit stop	
Connector:	SuB-D9 specific pinout with RS485 and TOD interfaces	TOD is RFU in ATSC1.0

<b>RS485</b>		
Standard:	RS485 Full or Half duplex	TX and RX signals only. Limited to the use for "TX control" part (does not fully control the exciter)
Electrical Level:	RS485 compatible	
Baud Rate:	9600 bauds to 115200 bauds	
Others:	No parity, 8 bits data, 1 bit stop	
Connector:	SuB-D9 specific pinout with RS232 and TOD interfaces	

## EXACT-V2 High End Rack Modulator / Exciter

TOD		
Standard:	RS232	Limited to RX signal
Electrical Level:	±12v compatible	
Baud Rate:	9600 bauds	
Others:	No parity, 8 bits data, 1 bit stop	
Connector:	SuB-D9 specific pinout with RS232 and RS485 interfaces	

### 3.5.4 ASI inputs / output and MPEG-TS processing

TS stream	Typical Value	Comment
<b>ASI / SMPTE Inputs</b>		
Format:	TS/DVB-ASI or TS/SMPTE-310M	
Packet Size:	188/204 bytes - Packet or Burst mode 188 bytes	DVB-ASI SMPTE-310M
Maximum Useful Bit Rate:	19.39 Mbps	DVB-ASI / SMPTE-310M
Max. Input Jitter:	+/- 100 ms	
Input Impedance:	75 ohms	
Return Loss:	> 15 dB up to 270 MHz	
<b>TS or T2-MI Processing</b>		
TS Stream switching: TS <i>CleverSwitch</i> : IP <i>CleverSwitch</i> :	Automatic or manual Between primary & sec. stream Between prim. & sec. IP stream	With auto or manual switch-back Not seamless Not seamless
TS processing	NIT update Bit rate adaptation PCR re-stamping	Carrier Frequency update
<b>ASI Output</b>		
Format:	TS over DVB-ASI	
Packet Size:	188 byte 188 byte	DVB-ASI SMPTE-310M
Maximum Useful Bit Rate:	19.39 Mbps 19.39 Mbps	DVB-ASI SMPTE-310M
Max. Output Jitter:	Same as incoming jitter	

## EXACT-V2 High End Rack Modulator / Exciter

### 3.5.5 Digital modulation

Characteristics	Typical Value	Comment
<b>ATSC Modulation</b>		
ATSC Mode:	8VSB	According to ATSC A/53
Channel Bandwidth:	6 MHz	

Characteristics	Typical Value	Comment
<b>Modulation Performances</b>		
In Band SNR (Eq. OFF):	$\geq 30$ dB	
EVM (Eq. OFF):	$\leq 2.0\%$	
MER (Eq. OFF):	$\geq 30$ dB	
MER (Eq. ON):	$\geq 45$ dB	
Shoulder and Out of Band Rejection:	$\geq 63$ dB  $\geq 57$ dB / $\geq 63$ dB with precor $\geq 63$ dB typical	From pilot level EXACT-V2  EXACT-V2-20dB at +20 dBm EXACT-V2-20dB at +17 dBm
Spurious:	$\leq -50$ dBc	Relative to the total power of the signal at nominal output power
Amplitude Ripple:	$\leq 0.2$ dB typical	
Group Delay Ripple:	$\leq 20$ ns typical	
Pilot Carrier Phase Noise:	$\leq -104$ dBc/Hz @ 20 kHz up to 700 MHz	
PAPR Configuration Range: Pre-clipping Optimization: Protection Clipping:	8 to 20 dB (0.1 dB step) 0 to 255 8 to 20 dB (0.1 dB step)	

Characteristics	Typical Value	Comment
<b>Miscellaneous</b>		
Automatic Mute:	Configurable on stream errors Configurable on clock errors	Configurable Timeout (LORS)
RF Maintain:	Configurable on stream errors	
Spectrum Reverse:	Configurable	
Test Modes:	Single sine tone / +6 dB Sinus PRBS	



**EXACT-V2 High End Rack Modulator / Exciter**
**3.5.6 Clock synchronization**

Characteristics	Typical Value	Comment
<b>External References</b>		
External 10 MHz Reference Input		
Impedance:	50 Ohms	
Level:	-15 to +15 dBm	
Frequency:	10 MHz $\pm$ 0.6 ppm	
External 1 PPS Reference Input		
Level:	LVTTL level – 5 kohms	
Min Pulse Width:	1 $\mu$ s	
10 MHz Reference Output:	0 dBm $\pm$ 3 dB	
1 PPS Reference Output		
Level:	LVTTL	
Pulse Width:	$\geq$ 100 ns	
Characteristics	Typical Value	Comment
<b>GPS Synchronization</b>		
System:	GPS	
Frequency:	1575.42 MHz	
Max Nb of Tracked Sat.:	12	
Antenna System Gain:	10 dB	
Sensitivity:	< -138 dBm	
PPS Accuracy:	$\pm$ 50 ns	
Antenna Power Supply:	3.3 Volts DC	

## EXACT-V2 High End Rack Modulator / Exciter

Characteristics	Typical Value	Comment
<b>Clocks &amp; Synchronization</b>		
10 MHz Lock Control Type:	Digital	
Internal 10 MHz clock		With OCXO
T° Stability (Full Temperature Range):	$< \pm 5.10^{-9}$	0 → 50 °C
Tuning:	$< \pm 0.6$ ppm	
Short Term Stability:	$< \pm 1.10^{-11}$	Over 1 s, 10 s
Aging:	$< \pm 5.10^{-10}$ / day $< \pm 7.5.10^{-8}$ / year $< \pm 5.10^{-7}$ / 15 years	
<i>Synchronization Cases</i>	<i>Stability</i> <i>Aging</i>	
External_10MHz_Locked:	$< \pm 3.10^{-10}$ -	
External_10MHz_Unlocked:	$< \pm 3.10^{-10}$ $< \pm 7.5.10^{-8}$ / year $< \pm 5.10^{-10}$ / day	Internal
Onboard GPS_Locked:	$< \pm 7.10^{-10}$ -	
Onboard GPS_Unlocked:	$< \pm 7.10^{-10}$ $< \pm 7.5.10^{-8}$ / year $< \pm 5.10^{-10}$ / day	Internal
Output Phase Noise:	$< -104$ dBc/Hz @ 20 kHz	Guaranteed from 470 MHz to 700MHz

**EXACT-V2 High End Rack Modulator / Exciter**

**3.5.7 RF and monitoring outputs**

Characteristics	Typical Value	Comment
<b>RF Output</b>		
Adjustable Frequency Range:	470 to 862 MHz 170 to 240 MHz 54 to 88 MHz	
Step Size:	1 Hz	
Accuracy:	0.2 Hz	
Impedance:	50 ohms	
Output Level: Main Signal:	0 dBm ± 1 dB +20 dBm ± 1 dB	EXACT-V2 EXACT-V2-20dB
Stability:	± 0.1 dB / 10 °C	EXACT-V2
Return Loss:	> 13 dB > 12 dB	EXACT-V2-20dB
Attenuation Range:	0 to 17 dB	
Attenuation Step:	0.1 dB	
Monitoring Signal: (Relative to Main Output)	-20 dB ± 2 dB -40 dB ± 2 dB	EXACT-V2 EXACT-V2-20dB

## EXACT-V2 High End Rack Modulator / Exciter

### 3.5.8 Digital precorrection

Characteristics	Typical Value	Comment
<b>Feedback Inputs</b>		
RF Frequency Band:	470 to 862 MHz 170 to 240 MHz 54 to 88 MHz	
Impedance:	50 ohms	
Return Loss:	> 13 dB	
Nominal Input Level:	-5 to -15 dBm	
Max Input Level:	+5 dBm (before damage)	
Adjacent Channel Rejection:	No adjacent channel support	

Characteristics	Typical Value	Comment
<b>Manual Precorrection</b>		
Linear Precorrection: Amplitude: Group Delay:	32 points $\pm 3$ dB (0.1 dB step) $\pm 500$ ns (10 ns step)	On the overall bandwidth
<b>Adaptive Precorrection</b>		
Linear Adaptive Precorrection Amplitude: Group Delay:	$\pm 3$ dB (0.1 dB step) $\pm 500$ ns (10 ns step)	
Non-Linear Adaptive Precorrection AM/AM: AM/PM:	$\pm 6$ dB (0.05 dB step) $\pm 25^\circ$ (0.2° step)	

Characteristics	Typical Value	Comment
<b>DAP Performances Measurement</b>		
RF Feedback Input Levels:	Bar graph 0-100 %	
Left and Right Shoulders:	On FBA or FBF input > 45 dB max	Resolution 1 dB
MER:	On FBA or FBF input For relative use only From 20 up to 40 dB Typical	The MER measurement should not be used as an absolute value. It can be used only for variation detection.

## EXACT-V2 High End Rack Modulator / Exciter

### 3.5.9 Power level measurement inputs and AGC

Characteristics	Typical Value	Comment
<b>Measurement Inputs (Forward and Reflected Power)</b>		
AC Impedance:	50 ohms	
DC Impedance:	~ 80 kohms	
Return Loss:	> 12 dB	
Nominal Input Level:	-10 to 0 dBm 0 to 5 Vdc	In RF power mode In DC voltage mode
Maximum Input Level:	+5 dBm / 6Vdc	
Accuracy:	0.5 dB typical 0.01 Vdc	In RF power mode In DC voltage mode May require significant calibration
Max Input Level:	+5 dBm (before damage)	
Reactivity Time:	1 s max	
Measurement Bandwidth:	Full bandwidth	
<b>Measurement Calibration</b>		
Configurable Coupler Gain:	0 to +100.0 dB	
Gain Step:	0.1 dB	
Configurable Probe Offset:	-32768 mV to +32767 mV	
Offset Step:	1 mV	
Configurable Probe Slope:	-100.00 to +100.00 dB/V -32768 to +32767 mVrms/V 0 to +65535 mW/V	for VDC/dBm type for VDC/Vrms type for VDC/W type
Slope Step:	0.01 dB/V 1 mVrms/V 1 mW/V	for VDC/dBm type for VDC/Vrms type for VDC/W type
<b>AGC</b>		
Maximum AGC Gain:	0 to 20.0 dB	
Maximum AGC Gain Step:	0.1 dB	
Nominal Power Level:	-100.0 to 100.0 dBm	
Nominal Power Level Step:	0.1 dB	

### 3.5.10 Dry contacts

Characteristics	Typical Value	Comment
<b>Relay characteristics</b>		
Maximum Switching Voltage:	25 Vac / 60 Vdc	
Maximum Switching Current:	1 A	
Maximum Switching Power:	62.5 VA / 30 W	
Available Contacts:	Normally open Normally close	

**EXACT-V2 High End Rack Modulator / Exciter****3.6 Conformity with EC Directive**

The CE marking is present on the RTM-50 product. It:

- Shows that we have checked that this product meets safety, health or environmental requirements
- Is an indication of a product's compliance with legislation
- Allows the free movement of products within the market

By placing the CE marking on our product we are declaring, on our own responsibility, conformity with all of the legal requirements to achieve CE marking.

**EXACT-V2 High End Rack Modulator / Exciter**

---

# 4 EXACT-V2 Installation

---

**EXACT-V2 High End Rack Modulator / Exciter**



## EXACT-V2 High End Rack Modulator / Exciter

### 4.1 Unpack the Unit

Please check the shipping container for any damage due to transportation when receiving the product. If there is any damage please contact the carrier immediately.

Carefully unpack the exciter from the storage box.

Check the exciter for any damage due to transportation.

Save the box and foam packaging in case the system needs to be shipped to another location or returned for repair.

### 4.2 Installation and Recommendations

Install the unit in the appropriate location using four, rack-mounting screws (not included) as shown in the following figure:



Figure 40: Chassis installation

#### Notes:

- Mechanical mounting into a rack must take into account any overloading to the mounting ears of the chassis to avoid danger.
- Rack connection to power supply must be taken into account for any electrical overload protection. A specific electrical study must be performed by integrator/installer.
- The equipment must be connected to power supply with a ground connection. Ground connection of the equipment must be checked before use.
- Installation must be performed by a qualified individual following the CEI60728-11: 2005 directive.

## EXACT-V2 High End Rack Modulator / Exciter

### 4.2.1 Temperature alarms

The maximum temperature levels are as follows:

- A warning will be raised when the internal temperature reaches higher than 68°C
- An alarm with output muting will trigger after internal temperatures reach higher than 71°C

In both cases, the normal status conditions return when the temperature falls below 67°C.

### 4.2.2 Cooling methods

Specific care must be taken concerning the cooling system. The following figure shows air flow due to internal fans. When the unit is integrated in an equipment cabinet, sufficient space must be left on the right and left side of the unit to allow sufficient air flow.



Figure 41: Rack air flow

## 4.3 Wiring and Powering on

Once fixed in a location, the exciter can be wired depending on its configuration.

When powered ON, the exciter is fully operational after a few seconds. Please refer to section 3.3 for a front panel LED diagnostic.

To simply control and monitor the EXACT, any web browser can be used with an IP connection between the exciter and the PC. The default IP address is 192.168.0.209 on IP port #1. The control port #1 IP configuration can be retrieved/modified using the front panel menu.

**Notes:** The power supply connector must remain available to easily disconnect the equipment in case of emergency.

## EXACT-V2 High End Rack Modulator / Exciter

### 4.4 Initial Configuration

Except otherwise specified at the time of order, the exciter is delivered with the basic configuration as described hereafter. The following configuration can also be retrieved with the "Set Default" command (not available in the WEB GUI) that will only keep IP settings and precorrection curves.

IP Parameters	Default Settings
Ethernet Mode:	Auto-sensing
DHCP	Disabled
Gigabit#1 Configuration: <i>(not changed by default command)</i>	MAC address: module unique address Address: 192.168.0.209 Subnet: 255.255.255.0 Gateway: 192.168.0.254 DHCP: OFF
Gigabit#2 SNMP <i>(not changed by default command)</i>	MAC address: module unique address Address: 192.168.0.211 Subnet: 255.255.255.0 Gateway: 192.168.0.254 DHCP: OFF
Gigabit#7 Front Panel Control <i>(not changed by default command)</i>	MAC address: module unique address Address: 192.168.0.210 Subnet: 255.255.255.0 Gateway: 192.168.0.254 DHCP: OFF
Gigabit#3 Input <i>(not changed by default command)</i>	MAC address: Port#2 unique address Address: 192.168.1.210 Subnet: 255.255.255.0 Gateway: 192.168.1.254
Gigabit#4 Input <i>(not changed by default command)</i>	MAC address: Port#2 unique address Address: 192.168.1.211 Subnet: 255.255.255.0 Gateway: 192.168.1.254
Gigabit#5 Input <i>(not changed by default command)</i>	MAC address: Port#2 unique address Address: 192.168.2.210 Subnet: 255.255.255.0 Gateway: 192.168.2.254
Gigabit#6 Input <i>(not changed by default command)</i>	MAC address: Port#2 unique address Address: 192.168.2.211 Subnet: 255.255.255.0 Gateway: 192.168.2.254
Gigabit #3, #4, #5, #6 Input Time Out	1 sec.

**Table 9: Default IP settings at the delivery**

# EXACT-V2 High End Rack Modulator / Exciter

## ATSC 1.0

Other Parameters	Default Settings
Standard: <i>(not changed by default command)</i>	ATSC
Test Mode:	Disabled
Serial Speed:	57600
Serial Protocol:	Standard
Auto Logout Time:	Off
ASI/SMPTE_IN1 Type:	ASI
ASI/SMPTE_IN2 Type:	ASI
ASI/SMPTE_IN1 Equalizer*:	Disabled
ASI/SMPTE_IN2 Equalizer*:	Disabled
Primary Source:	ASI/SMPTE_IN1
Secondary Source:	ASI/SMPTE_IN2
ASI Output	OFF
TS <i>CleverSwitch</i> :	Enabled
Auto_Switch_Back:	Disabled
Packet error threshold:	5
Packet valid threshold:	80000
ATSC signalization:	8-VSB
ASI management unit (Bit rate adaptation):	Enable
Major Channel number update:	Disable
Major Channel number:	0
Carrier Frequency update:	Disable
Carrier Frequency for Carrier Frequency Update:	665 MHz
Bandwidth:	6 MHz
Center Frequency (ATSC) *:	665 MHz (channel 46)
Output Attenuation (ATSC) *:	0 dB
Crest Factor:	10.0 dB
Crest Factor Optimization:	0
Protection Clipping:	15 dB
Spectrum Inversion:	No
RF Output Monitoring:	Enabled
Exciter RF Failure Offset:	5.0 dB
Starting Delay	5 seconds
AGC	Off
AGC Maximum Gain	0 dB
AGC Response Time	Nominal

## EXACT-V2 High End Rack Modulator / Exciter

Mute Conditions:	GPI=0: Disabled GPI=1: Disabled
Mute:	Disable
RFP Warning AGC Protection:	Disabled
RFP Error Protection Cycle:	Disabled
RFP Error Protection – No. of Retries:	3
RFP Error Protection – Delay Between Retries:	4
RFP Error Protection – Cycle Reset Time:	60
RF Maintain:	On Input Stream Error: Enabled
Enable Down-Converter:	Enabled
DAP Mode:	Off (standard)
Linear Precorrection Circuits* :	Disabled (Bypassed)
Non-Linear Precorrection circuits* :	Disabled (Bypassed)
Linear DAP Mode:	Static (DAP is disabled)
Non-Linear DAP Mode:	Static (DAP is disabled)
Linear DAP Time_Out:	20 min
Non-Linear DAP Time_Out:	10 min
Primary Clock:	Internal
Secondary Clock:	Internal
PPS Source:	Onboard GPS
PPS Interface:	Output
PPS Edge (RFU):	Rising
Warm-Up Time (Before 10MHz Synchro):	Enabled
GPS Antenna Voltage:	3.3 VDC
Absolute Reference Time:	GPS
Time and Date Setting:	Manual
Power Measurements: <i>(not changed by default command)</i>	Active
FWP Input Type: <i>(not changed by default command)</i>	RF input
FWP Coupler Attenuation: <i>(not changed by default command)</i>	0 dB
Nominal Power: <i>(not changed by default command)</i>	0 dBm
Min FWP Error: <i>(not changed by default command)</i>	80 %
Min FWP Warning: <i>(not changed by default command)</i>	90 %
Max FWP Warning: <i>(not changed by default command)</i>	110 %

**EXACT-V2 High End Rack Modulator / Exciter**

Max FWP Error: <i>(not changed by default command)</i>	120 %
RFP Input Type: <i>(not changed by default command)</i>	RF input
RFP Coupler Attenuation: <i>(not changed by default command)</i>	0 dB
Max RFP Warning: <i>(not changed by default command)</i>	10 %
Max RFP Error: <i>(not changed by default command)</i>	20 %
Dual-Drive Redundancy:	Disabled
GPO2 Opening Triggers:	None
GPO3 Opening Triggers:	Output error Alarm error
RF Switch Monitoring:	Disabled
Transmitter Control:	Disabled

**\*Note:** different set of parameters are used for Single Carrier modulation (ATSC) and OFDM modulation (future ATSC 3.0) in regards to their:

- Frequency (Carrier frequency in ATSC // Center frequency in ATSC 3.0)
- Attenuation
- Gain offset
- Linear Precorrection activation (with separate curves banks)
- Non-Linear Precorrection activation (with separate curves banks)

**\*Note:** On the WEB GUI, the input equalizer is automatically changed to « disabled » when the user selects the « SMPTE » input type.

ATSC 3.0 (Available from the S110 firmware version)

**EXACT-V2 High End Rack Modulator / Exciter**

---

# 5

# Operation

---

**EXACT-V2 High End Rack Modulator / Exciter**



## EXACT-V2 High End Rack Modulator / Exciter

### 5.1 Operation Generalities

#### 5.1.1 Local Operation

The product can be locally controlled using the front panel menu. It is composed of an LCD screen and 6 buttons to navigate the control/monitoring menu.

The primary features are available using the front panel but for complete access to the unit, please use the web GUI.

#### 5.1.2 Remote Operation

The product can be controlled using any web browser. It allows the user to control, monitor, and maintain the unit.

Below are the system requirements:

- PC using a Pentium 1GHz or higher microprocessor
- Microsoft Windows Vista/XP or Windows 2000 Service Pack 3 or later
- 1024 x 768 resolution (or higher) video adapter
- Minimum of 128 MB of RAM (256 MB recommended)
- 120 MB of disk space
- A Microsoft-compatible mouse



**Figure 42: EXACT-V2 IP connection**

The web GUI can be accessed via any web browser using the IP address of the unit. By default, this address is 192.168.0.209. The IP address can be retrieved/modified using the front panel menu.

**EXACT-V2 High End Rack Modulator / Exciter**

**5.2 Embedded Web GUI Description**

**5.2.1 Requirements**

To connect to the EXACT-V2 web interface, a web browser with Flash Player is mandatory.

**5.2.2 Connection to EXACT-V2**

Using the web browser, the user will access the modulator by typing "[http://\[IP\]](http://[IP])", where [IP] is the IP address of the equipment. This address can be retrieved using the front panel display menu: **MANAGEMENT > Control IP Port > Add**

To access any settings of the EXACT-V2 unit, a login is required. There are 3 logins:

- o User (Guest): Only monitoring of the equipment is allowed
- o Maintenance: Minor changes are allowed like test mode, input management, precorrections, mute/unmute, clock and synchronization, etc.
- o Administrator: Complete access to the equipment

To login, the user will choose their access level, type the password and click on the "Login" button. There is no password for the "Guest" account. Both the "Administrator" and "Maintenance" accounts have the same password: **admin**

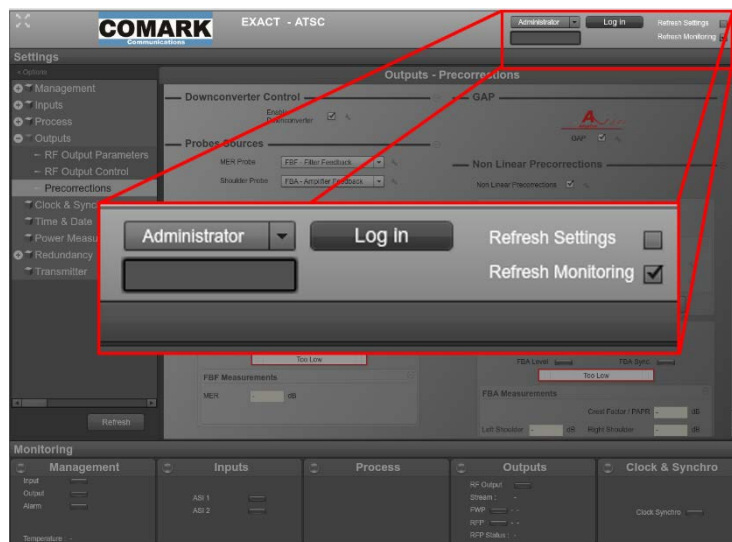

Depending on the granted access level, each parameter that can be modified by the user will be followed by a small "tool" icon.

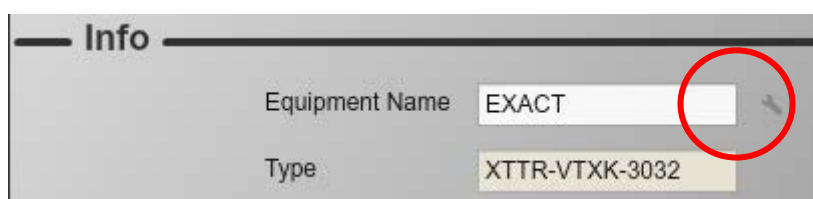

# EXACT-V2 High End Rack Modulator / Exciter

## 5.2.3 General Overview



Area 1 is the header of the main window. It presents the login/logout functions as well as equipment identification.

Area 2 is the main window. It presents either the parameters settings or the detailed monitoring.

Area 3 is the "Status Overview" area. It presents an overview of the main status.

**EXACT-V2 High End Rack Modulator / Exciter****5.2.4 Settings Tab**

The **Settings** tab can be accessed by clicking on the « Settings » header.

The screenshot displays the COMARK EXACT-ATSC web interface. The top navigation bar includes the COMARK logo, the title 'EXACT - ATSC', and user controls like 'Administrator', 'Log out', 'Refresh Settings', and 'Refresh Monitoring'. The main interface is split into a left sidebar menu and a main content area. The sidebar menu lists various settings categories such as Management, Inputs, Process, Outputs, Clock & Synchro, Time & Date, Power Measurements, Redundancy, and Transmitter. The main content area is titled 'Management - General' and contains several sections: 'Info' (Equipment Name: EXACT, Type: XTTR-VTXK-3032, S/N: 00195, Hard. Version: 0101, Soft. Version: 112), 'Standard' (Standard: ATSC 1.0), and 'Control / Gigabit 1' (Address: 192.168.255.209, Subnet Mask: 255.255.255.0, Gateway: 192.168.255.254, MAC: 00:18:D3:00:8F:9C, DHCP: unchecked). There are also 'Test' and 'Miscellaneous' sections. The 'Test' section has a 'Test Mode' dropdown set to 'PRBS'. The 'Miscellaneous' section has 'Serial Speed' (57600 bps), 'Serial Protocol' (Standard), and 'Auto Logout Time' (0 min). Buttons for 'Firmware Upgrade...', 'Reboot...', and 'About...' are visible. A red arrow points to the 'Settings' header in the top right corner. Below the settings is a 'Monitoring' section with five panels: Management (Input, Output, Alarm), Inputs (ASI 1, ASI 2), Process, Outputs (RF Output, Stream: PRBS, FWP: 263 mW 24.2 dBm, RFP: 0.263 μW -35.8 dBm, RFP Status: OK), and Clock & Synchro (Clock Synchro). A temperature indicator shows 43°C.

The left part of the screen describes the settings menu while the right part presents each screen related to one menu item.

When any parameter is changed, it is highlighted.



# EXACT-V2 High End Rack Modulator / Exciter

A message in the main window header allows the user to verify if the settings have been modified and not applied.



The **Apply** button appears to confirm the application.

The screenshot displays the web interface for the EXACT - ATSC device. The top header shows the COMARK logo and the text 'EXACT - ATSC Settings are modified'. The main content area is titled 'Management - General' and contains several sections: 'Info' (Equipment Name: EXACT, Type: XTTR-VTXK-3032, S/N: 00195, Hard. Version: 0101, Soft. Version: 112), 'Standard' (Standard: ATSC 1.0), and 'Control / Gigabit 1' (Address: 192.168.255.209, Subnet Mask: 255.255.255.0, Gateway: 192.168.255.254, MAC: 00:18:D3:00:8F:9C, DHCP: unchecked). There are also 'Test' and 'Miscellaneous' sections. At the bottom left, a red arrow points to the 'Apply' button. The bottom of the interface features a 'Monitoring' section with five panels: Management (Input, Output, Alarm), Inputs (ASI 1, ASI 2), Process, Outputs (RF Output, Stream, FWP, RFP), and Clock & Synchro.

If any change must be discarded, the « Refresh » button can be used to display the current configuration in the settings screens.

# EXACT-V2 High End Rack Modulator / Exciter

## 5.2.5 Monitoring Tab

The **Monitoring** tab can be accessed clicking on the **Monitoring** header.

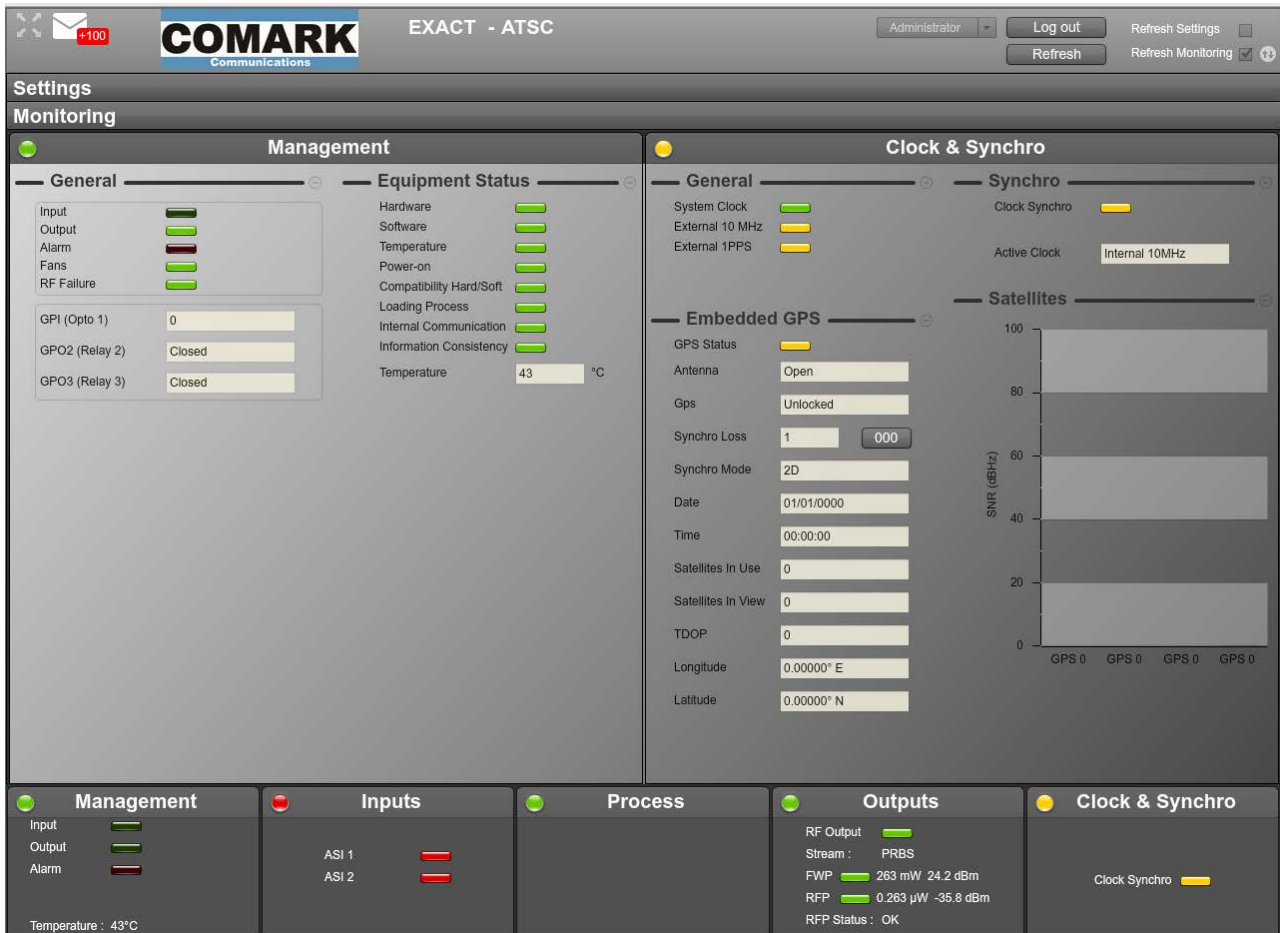

It is divided into 2 independent screens to allow the user to monitor two different blocks.

To select a block to monitor, a Drag and Drop feature can be used from the "Status Overview" area to one of the two areas.



## EXACT-V2 High End Rack Modulator / Exciter

### 5.2.6 Log File

EXACT-V2 features an onboard Log file to consult the different information, warning or error that occurred on the product.

To access to the Log File window, please press the envelop.



Then the log file window is displayed.

Line	Date	Time	Category	Severity	Description	ID	State	Trigger Value
395	2016-08-08	15:01:09	Alarm	CRITICAL	Atsc_Output_Fwp_MinErrorDown	4040204	Clear	97 %
394	2016-08-08	15:01:09	Alarm	WARNING	Atsc_Output_Fwp_MinWarningDown	4040203	Clear	97 %
393	2016-08-08	15:01:04	Alarm	CRITICAL	System Clock	8	Clear	
392	2016-08-08	15:01:03	Alarm	INFO	Atsc_Clock_Correct_Correction	4050404	Active	0

**Notes:** For more information concerning this topic, please refer to the dedicated Application Note.

### 5.3 Front Panel Menu Description

Main settings can be accessed from the EXACT-V2 front panel display (FPD).



Menu navigation is done using the keypad on the right side of the LCD screen.

**EXACT-V2 High End Rack Modulator / Exciter**



**EXACT-V2 High End Rack Modulator / Exciter**

---

# 6

## Maintenance & Troubleshooting

---

**EXACT-V2 High End Rack Modulator / Exciter**

## EXACT-V2 High End Rack Modulator / Exciter

### 6.1 Versions management

The product is defined by its commercial reference and its version numbers.

Product versions are managed using two separate and independent three digits numbers:

- The hardware version
- The software version

The version of the product is defined for example as: ..... **H100-S112**

This means that the hardware of the product is in version 1.00 and the software is in version 1.10.

These version ID's can be read from the Web GUI.

### 6.2 Software updates

Software updates can be made by the user. New software can be provided by the Hitachi-Comark customer service depart.

To request the latest updates, please contact our Customer Service Department by sending an email to [service@comarktv.com](mailto:service@comarktv.com) or by calling 800-345-9295.

For each software version available, a unique file ("customer pack") has to be provided by Hitachi-Comark. It is labeled as **EXACT-H100-S112.zip**, where EXACT-V2 is the commercial reference of the product to which it applies to, H100 gives the minimum hardware version required by this new software version, and S100 is the new software version

This customer pack contains:

- The firmware for ftp download (IP connection) referred to as EXACT-3000-S0100-B0301.tfw
- The Upgrade Procedure (.pdf file) explaining how to perform the update
- The release notes
- The User Manual
- Any additional software, if needed

The software upgrade is done using the Web GUI of the product:

- Copy the \*.tfw file on your local hard disk.
- Access to the web GUI and go to "Management / General" tab.
- Click on the "Firmware Upgrade" button
- Select the new release file on your local hard disk.

The product will then automatically reboot to take into account the new release.

**EXACT-V2 High End Rack Modulator / Exciter**

**6.3 Licence key management**

New licences for either TSOIP or SNMP may be purchased separately and added to the exciter. For this purpose:

- o Access the web GUI and go to the "Management / Options" tab
- o Select the desired option to unlock by clicking on the associated "Unlock" button
- o Enter the key code that is provided by Hitachi-Comark following the licence order

The product then automatically reboots and the new licence is taken into account.

**6.4 Troubleshooting of the exciter**

**6.4.1 LED Check**

If the exciter does not work properly, a few checks could be done before calling the technical support team at Hitachi-Comark.

A set of 4 LEDs indicates the modulator status following the *Hitachi-Comark* standard, Power, Input, Output and Alarm LED indicators.

Name	Description
Power	Green off: power off Green fix: power on
Input	Green off: Primary input is not detected (in manual mode) or primary and secondary input is not detected (in auto mode) Green flashing: Primary input is OK <sup>(1)</sup> but secondary input is OK (in auto mode) Green fixed: Primary input is ok <sup>(1)(4)</sup>
Output	Green off: no RF output (module failure or mute condition) Green fixed: the RF output is available (normal mode) Green flashing: Test signal <sup>(2)</sup> is generated or RF Maintain mode
Alarm	Off: No critical error detected Red fixed : Module failure Red flashing : Primary input failure <sup>(3)</sup> or primary clock reference <sup>(5)</sup> loss (10 MHz or PPS in case of ext 10MHz + ext 1PPS primary selection)

**Table 10: LED Analysis**

- (1) If primary input is detected but any condition for "Mute on TS error" is met, the input LED is flashing.
- (2) PRBS, Sine, or any special test.
- (3) Except in case of PRBS or Sine test mode.
- (4) In automatic mode, if the primary input is detected, the input LED is fixed at whatever the secondary input status is.

**EXACT-V2 High End Rack Modulator / Exciter**

(5) Alarm due to primary clock reference loss is defined in a specific table.

**6.4.2 Contact the technical support**

**Before contacting Hitachi-Comark Technical Support Team**, please ensure you can provide them with following information:

- The type, hardware and software version and Serial number of the equipment
- The delivery date of the equipment
- Symptoms of the breakdown or a description of the problem

**HITACHI-COMARK CUSTOMER SUPPORT**

Tel. + 800-345-9295

Email : [support@comarktv.com](mailto:support@comarktv.com)

The technical support team of Hitachi-Comark is present to answer your questions and try to understand the problem that may be encountering with your exciter. They will be able to help you to identify the problem or give you recommendations on how to return the unit to the factory.

**EXACT-V2 High End Rack Modulator / Exciter**

**EXACT-V2 High End Rack Modulator / Exciter**

---

## Appendix

# A

## GPS Installation Recommendations

---

**EXACT-V2 High End Rack Modulator / Exciter**



**EXACT-V2 High End Rack Modulator / Exciter**



While doing GPS installation and setup for a product with an embedded GPS receiver, it is highly recommended to respect the following conditions:

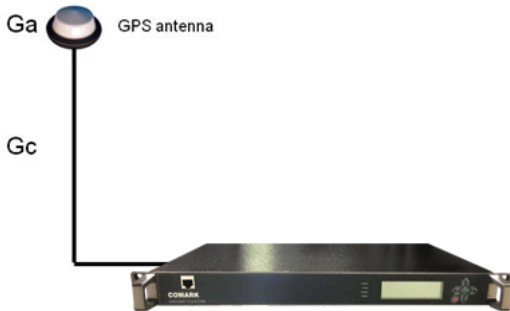

Considering:

**Pgps** as the power of the incoming signal (nominal value over the covered area)

**Ga** as the gain of the dedicated GPS antenna

**Gc** as the losses of the several RF components (cable, connectors,...)

**Gt** as the total Gain of the RF chain

$$Gt = Ga + Gc$$

The user shall respect the following condition:

$$20 \text{ dB} \leq Gt \leq 35 \text{ dB}$$

In order to fulfill this condition, and if **Gt** is not sufficient, the user can also add a line Amplifier, as shown in the drawing below:



with  $Gt = Ga + Gc + Gamp$

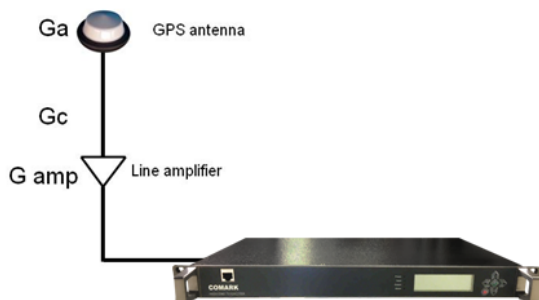

**Warning:** For the GPS reception to be optimal, it is highly recommended to place the Antenna in an open, free space (top of the building, etc.)

**EXACT-V2 High End Rack Modulator / Exciter**

**EXACT-V2 High End Rack Modulator / Exciter**

---

## Appendix

# B Example of GPS Antenna

---

**EXACT-V2 High End Rack Modulator / Exciter**

**EXACT-V2 High End Rack Modulator / Exciter**

The right one.™

**BULLET III GPS ANTENNA****KEY FEATURES**

- Waterproof and corrosion-resistant housing filtering for harsh RF jamming environments
- Proven extra rugged, reliable
- Available in 3.3v (TNC) or 5v (TNC or F)
- RoHs compliant (Pb free)

**JAM-RESISTANT ACTIVE GPS ANTENNA NOW AVAILABLE FOR USE WITH 3.3 V DC AND 5 V DC APPLICATIONS**

Whatever the environment—the Trimble® Bullet™ III GPS antenna will perform, year after year. The Bullet III antenna provides a perfect solution for manufacturers who need a fixed-site, rooftop GPS antenna. This antenna is also a high-quality solution for adding GPS RF signals for marine GPS navigation systems.

**Put it anywhere**

The antenna is housed in weatherproof packaging designed to withstand exposure to shock, excessive vibration, extreme temperatures, rain, snow and sunlight.

The dome is all plastic, and the threaded socket in the base of the antenna is corrosion resistant. The threaded socket accepts either a 1"-14" straight thread (typical marine antenna mount) or a 3/4" pipe thread.

The F-type or TNC antenna connector is located inside the threaded socket, which allows the antenna cable to be routed inside a mounting pole and protects the cable connection for added reliability.

**Strong performance**

The Bullet III antenna is an active GPS antenna with 35 dB preamp (5 V DC), 30 dB preamp (3.3 V DC). The high-gain preamp allows the Bullet III antenna to be used with up to 75 feet of RG-59 cable. The Bullet III filtering improves immunity to other RF signals for reliable performance in hostile RF jamming environments.

**Proven reliability**

For over 15 years, Trimble has sold GPS antennas renowned for their survivability in tough environments. The Bullet III antenna is the fourth generation of the proven Bullet antenna family and offers all the reliability and performance benefits that are required for GPS installations.

In unforgiving environments, an antenna failure could be disastrous. Don't risk it. Select a proven GPS antenna—the Trimble Bullet III GPS antenna.

**EXACT-V2 High End Rack Modulator / Exciter**

**BULLET III GPS ANTENNA**

**ENVIRONMENTAL SPECIFICATIONS**

Operating Temp.....-40 °C to +85 °C  
 Storage Temp.....-40 °C to +100 °C  
 Vibration..... 10-200 Hz Log sweep  
 3 g (Sweep time 30 minutes) 3 axes  
 Shock......50 g vertical, 30 g all axes  
 Humidity..... Mil-STD-810E  
 Corrosion..... 5% Salt spray  
 Waterproof..... Immersion to 1 meter

**PHYSICAL CHARACTERISTICS - 3.3 V DC AND 5 V DC ANTENNAS**

Dimensions..... 3.05" D x 2.61" H (77.5 mm x 66.2 mm)  
 Weight..... 6.0 oz (170 grams)  
 Enclosure..... Off-white plastic  
 Connector..... F-type & TNC (5 V DC) - TNC (3.3 V DC only)  
 Mounting..... 1"-14" thread or 3/4" pipe thread

**TECHNICAL/PERFORMANCE SPECIFICATIONS**

	3.3v	5v
Prime Power	3.3 V DC (±10%)	+5 V DC (±10%)
Power consumption	<20 mA	30 mA maximum
Gain	30 dB @ 25 °C	35 dB ± 3 dB
Output Impedance	50Ω	50Ω
Frequency	1575.42 MHz ± 1.023 MHz	1575.42 MHz ± 1.023 MHz
Polarization	Right-hand circular polarization (RHCP)	Right-hand circular polarization (RHCP)
VSWR	2.0 maximum	2.0 maximum
Axial ratio	90°: 4.0 dB maximum; 10°: 6 dB maximum	90°: 4.0 dB maximum; 10°: 6 dB maximum
Noise	3.3 dB maximum (25 °C ±5 °C)	3.3 dB maximum (25 °C ±5 °C)
Pass-band width	50 MHz	50 MHz
Out of Band rejection	f<=1575.42 MHz f>=20 MHz: 7 dB min f>=30 MHz: 12 dB min f>=50 MHz: 20 dB min f>=100 MHz: 30 dB min	f<=1575.42 MHz f>=20 MHz: 7 dB min f>=30 MHz: 12 dB min f>=50 MHz: 20 dB min f>=100 MHz: 30 dB min
Azimuth coverage	360° (omni-directional)	360° (omni-directional)
Elevation coverage	0° to 90° elevation (hemispherical)	0° to 90° elevation (hemispherical)

**MECHANICAL**

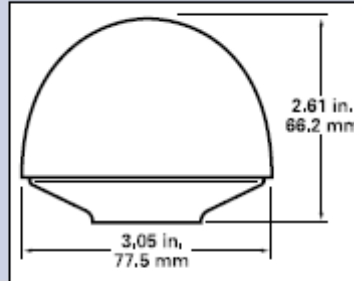

**CONNECTORS**



TNC (3.3v only)

F-type (3.3v or 5v)

**ORDERING INFORMATION AND ACCESSORIES**

Please go to [www.trimble.com/timing](http://www.trimble.com/timing) for the latest documentation & tools, part numbers and ordering information

Trimble has relied on representations made by its suppliers in certifying this product as RoHS compliant.

Specifications subject to change without notice.

Trimble Navigation Limited is not responsible for the operation or failure of operation of GPS systems or the availability of GPS satellite signals.

**NORTH AMERICA**  
 Trimble Navigation Limited  
 Corporate Headquarters  
 935 Stewart Drive  
 Sunnyvale, CA 94085  
 +1-800-787-4225  
 +1-408-481-7741  
 timing@trimble.com

**EUROPE**  
 Trimble Navigon Europe  
 Phone: +49-6142-2100-161

**KOREA**  
 Trimble Export Ltd, Korea  
 Phone: +82 2 555 5361

**CHINA**  
 Trimble Navigation Ltd, China  
 Phone: +86-21-6391-7814



© 2006-2007, Trimble Navigation Limited. All rights reserved. Trimble and the Globe & Triangle logo are trademarks of Trimble Navigation Limited, registered in the United States Patent and Trademark Office and in other countries. Bullseye and The right eye logo are trademarks of Trimble Navigation Limited. All other trademarks are the property of their respective owners. PN 02562-032 02/07



[www.trimble.com](http://www.trimble.com)