



TEST REPORT

Test Report No. : UL-RPT-RP-11909763-3616-FCC-UNII2A

Applicant : SIEMENS AG
Model No. : MPCIE-R1-ABGNAC-U4
FCC ID : LYHRAPACV1
Technology : WLAN 5 GHz
Test Standard(s) : FCC Parts 15.207 & 15.407(a)(2)

For details of applied tests refer to test result summary

1. This test report shall not be reproduced in full or partial, without the written approval of UL International Germany GmbH.
2. The results in this report apply only to the sample tested.
3. The test results in this report are traceable to the national or international standards.
4. Test Report Version 1.0
5. Result of the tested sample: Pass

Prepared by: Krume, Ivanov
Title: Laboratory Engineer
Date: 04 March 2020

Approved by: Ajit, Phadtare
Title: Lead Test Engineer
Date: 04 March 2020



Deutsche
Akkreditierungsstelle
D-PL-19381-02-00

This laboratory is accredited by DAkkS.
The tests reported herein have been performed in
accordance with its' terms of accreditation.

This page has been left intentionally blank.

Table of Contents

1. Customer Information.....	4
1.1. Applicant Information	4
1.2. Manufacturer Information	4
2. Summary of Testing.....	5
2.1. General Information	5
Applied Standards	5
Location	5
Date information	5
2.2. Summary of Test Results	6
2.3. Methods and Procedures	6
2.4. Deviations from the Test Specification	6
3. Equipment Under Test (EUT)	7
3.1. Identification of Equipment Under Test (EUT)	7
3.2. Description of EUT	7
3.3. Modifications Incorporated in the EUT	7
3.4. Additional Information Related to Testing	8
3.5. Antenna Information	9
3.6. Support Equipment	9
A. Support Equipment (In-house)	9
B. Support Equipment (Manufacturer supplied)	9
4. Operation and Monitoring of the EUT during Testing	10
4.1. Operating Modes	10
4.2. Configuration and Peripherals	11
4.3. Used Power Settings & Port Terminations	12
4.4. Used RF Cables	13
5. Measurements, Examinations and Derived Results	14
5.1. General Comments	14
5.2. Test Results	15
5.2.1. Transmitter AC Conducted Spurious Emissions	15
5.2.2. Transmitter 26 dB Emission Bandwidth	23
5.2.3. Transmitter Duty Cycle	129
5.2.4. Transmitter Maximum Conducted Output Power	160
5.2.5. Transmitter Maximum Power Spectral Density	324
6. Measurement Uncertainty	464
7. Used equipment	465
8. Report Revision History	466

1. Customer Information

1.1.Applicant Information

Company Name:	SIEMENS AG
Company Address:	Östliche Rheinbrückenstr. 50, 76187 Karlsruhe, Germany
Contact Person:	Dr. Malgorzata Janson
Contact E-Mail Address:	malgorzata.janson@siemens.com
Contact Phone No.:	+ 49 721 595 2606

1.2.Manufacturer Information

Company Name:	SIEMENS AG
Company Address:	76181 Karlsruhe, Germany
Contact Person:	Mr. Kilian Löser
Contact E-Mail Address:	kilian.loeser@siemens.com
Contact Phone No.:	+49 911 895-5363

2. Summary of Testing

2.1. General Information

Applied Standards

Specification Reference:	47CFR15.407 and 47CFR15.403
Specification Title:	Code of Federal Regulations Volume 47 (Telecommunications): Part 15 Subpart E (Unlicensed National Information Infrastructure Devices) – Sections 15.403 and 15.407
Specification Reference:	47CFR15.207
Specification Title:	Code of Federal Regulations Volume 47 (Telecommunications): Part 15 Subpart C (Intentional Radiators) - Sections 15.207
Test Firm Registration:	399704

Location

Location of Testing:	UL International Germany GmbH Hedelfinger Str. 61 70327 Stuttgart Germany
-----------------------------	--

Date information

Order Date:	26 September 2017
EUT arrived:	26 January 2018
Test Dates:	15 February 2020 to 9 March 2020
EUT returned:	-/-

2.2. Summary of Test Results

Clause	Measurement (5.25-5.35 GHz band)	Complied	Did not comply	Not performed	Not applicable
Part 15.207 / Part 15.407(b)(6)	Transmitter AC Conducted Emissions	<input checked="" type="checkbox"/>	<input type="checkbox"/>	<input type="checkbox"/>	<input type="checkbox"/>
Part 15.403(i)	Transmitter 26 dB Emission Bandwidth	<input checked="" type="checkbox"/>	<input type="checkbox"/>	<input type="checkbox"/>	<input type="checkbox"/>
Part 15.35(c)	Transmitter Duty Cycle	<input checked="" type="checkbox"/>	<input type="checkbox"/>	<input type="checkbox"/>	<input type="checkbox"/>
Part 15.407(a)(2)	Transmitter Maximum Conducted Output Power	<input checked="" type="checkbox"/>	<input type="checkbox"/>	<input type="checkbox"/>	<input type="checkbox"/>
Part 15.407(a)(2)	Transmitter Power Spectral Density	<input checked="" type="checkbox"/>	<input type="checkbox"/>	<input type="checkbox"/>	<input type="checkbox"/>
Part 15.407(b)/ 15.209(a)	Transmitter Out of Band Conducted Emissions ^(Note 1)	<input type="checkbox"/>	<input type="checkbox"/>	<input checked="" type="checkbox"/>	<input type="checkbox"/>
Part 15.407(b)/ 15.209(a)	Transmitter Out of Band Radiated Emissions ^(Note 1)	<input type="checkbox"/>	<input type="checkbox"/>	<input checked="" type="checkbox"/>	<input type="checkbox"/>
Part 15.407(b)/ 15.209(a)	Transmitter Band Edge Radiated Emissions ^(Note 1)	<input type="checkbox"/>	<input type="checkbox"/>	<input checked="" type="checkbox"/>	<input type="checkbox"/>
Part 15.407(g)	Transmitter Frequency Stability ^(Note 2) (Temperature & Voltage Variation)	<input type="checkbox"/>	<input type="checkbox"/>	<input type="checkbox"/>	<input checked="" type="checkbox"/>
Part 15.407(h)(1)	Transmitter Power Control	<input type="checkbox"/>	<input type="checkbox"/>	<input type="checkbox"/>	<input checked="" type="checkbox"/>

Note:

1. Refer separate test report : UL-RPT-RP11909763-3616A.pdf
2. As per applicant's user manual Frequency stability is better than 20 ppm which ensures that the signal remains in the allocated bands under all operational conditions stated in the user manual.

2.3. Methods and Procedures

Reference:	ANSI C63.10-2013
Title:	American National Standard of Procedures for Compliance Testing of Unlicensed Wireless Devices
Reference:	KDB 789033 D02 General U-NII Test Procedures New Rules v02r01 December 14, 2017
Title:	Guidelines for Compliance Testing of Unlicensed National Information Infrastructure (U-NII) Devices – Part 15, Subpart E
Reference:	KDB 662911 D01 Multiple Transmitter Output v02r01 October 31, 2013
Title:	Emissions Testing of Transmitters with Multiple Outputs in the Same Band
Reference:	KDB 174176 D01 Line Conducted FAQ v01r01 June 3, 2015
Title:	AC Power-Line Conducted Emissions Frequently Asked Questions

2.4. Deviations from the Test Specification

For the measurements contained within this test report, there were no deviations from, additions to, or exclusions from the test specification identified above.

3. Equipment Under Test (EUT)

3.1. Identification of Equipment Under Test (EUT)

Brand Name:	SIEMENS
Model Name or Number:	MPCI-E-R1-ABGNAC-U4
Model Type:	A5E36528526
Serial/ Fixed IP Number:	192.168.0.65 (Conducted Test Sample)
Hardware Version Number:	1
Software Version Number:	V02.00.00
FCC ID:	LYHRAPACV1

Brand Name:	SIEMENS
Model Name or Number:	MPCI-E-R1-ABGNAC-U4
Model Type:	A5E36528526
Serial/ Fixed IP Number:	192.168.0.70 (AC Conducted Test Sample)
Hardware Version Number:	1
Software Version Number:	V02.00.00
FCC ID:	LYHRAPACV1

3.2. Description of EUT

The equipment under test was a 4 X 4 MIMO radio module supporting WLAN 2.4 GHz & WLAN 5 GHz technologies.

3.3. Modifications Incorporated in the EUT

No modifications were applied to the EUT during testing.

3.4. Additional Information Related to Testing

Technology Tested:	WLAN (IEEE 802.11a,n, ac)		
Type of Unit:	Transceiver		
Test Evaluation Board Power Supply Requirement(s):	Nominal	24.0 V DC	
	Minimum	16.8 V DC	
	Maximum	31.2 V DC	
EUT Power Supply Requirement(s):	Power Range	3.3 V DC \pm 5 %	520 mA
	Power Range	5.0 V DC \pm 5 %	700 mA
Supported Modulation Types:	BPSK, QPSK, 16QAM, 64QAM, 256QAM		
Supported Data rates:	802.11a	6, 9, 12, 18, 24, 36, 48 & 54 Mbit/s (SISO or MIMO)	
	802.11n HT20	MCS0 to MCS7 (1 spatial stream) MCS8 to MCS15 (2 spatial streams) MCS16 to MCS23 (3 spatial streams) MCS24 to MCS31 (4 spatial streams)	
	802.11n HT40	MCS0 to MCS7 (1 spatial stream) MCS8 to MCS15 (2 spatial streams) MCS16 to MCS23 (3 spatial streams) MCS24 to MCS31 (4 spatial streams)	
	802.11ac HT20	MCS0 to MCS8 (up to 4 spatial streams)	
	802.11ac HT40	MCS0 to MCS9 (up to 4 spatial streams)	
	802.11ac HT80	MCS0 to MCS9 (up to 4 spatial streams)	
Antenna Gains:	Refer section 3.5 Antenna Information		
Maximum Conducted Output Power:	20 MHz	16.1 dBm	
	40 MHz	10.9 dBm	
	80 MHz	10.6 dBm	
Transceiver Frequency Band:	5250 MHz to 5350 MHz [U-NII-2A Band]		
Nominal Channel Bandwidth	20 MHz		
Transmit Channels Tested:	Channel ID	Channel Number	Channel Frequency (MHz)
	Bottom	52	5260
	Bottom +1	56	5280
	Top -1	60	5300
	Top	64	5320
Nominal Channel Bandwidth	40 MHz		
Transmit Channels Tested:	Bottom	54	5270
	Top	62	5310
Nominal Channel Bandwidth	80 MHz		
Transmit Channels Tested:	Single	58	5290

3.5. Antenna Information

Antenna types with highest antenna gains amongst their supported radiation patterns were used for the EUT testing:

Antenna Type:	9 dBi Antenna
Antenna Radiation Type:	Sector
Antenna Model Number:	ANT795-6DC
Antenna Gain:	9 dBi @ 5 GHz
Antenna Beamwidth:	55°H / 55°V
Antenna Connector Type:	N
Manufacturer Article Number:	6GK5795-6DC00-0AA0
Batch Number:	006.707039

3.6. Support Equipment

The following support equipment was used to exercise the EUT during testing:

A. Support Equipment (In-house)

Item	Description	Brand Name	Model Name or Number	Serial Number
1	Laptop	Lenovo	L560	MP-16X73B 16/11
2	Lab DC Power Supply	Conrad Electronic	PS-2403D	Not stated
3	Lab Voltage Rectifier Power Supply	Spitzenberger Spies	PAS 5000	A2464 00/2 0200

B. Support Equipment (Manufacturer supplied)

Item	Description	Brand Name	Model Name or Number	Serial Number
1	DC Power Supply Cable (Length: 0.5 m Quantity: 2 Pcs)	--	Standard 2 wire cable	--
2	M12- RJ45 Ethernet Cable (Length: 2 m Quantity: 2 Pcs)	SIEMENS	LEONI L INDUSTRIAL ETHERNET FLEXIBLE 6XV1870-2E	--
3	Test Evaluation Board (Quantity: 2 Pcs)	SIEMENS	A5E36374290-AE GTW 18 94V-0	--
4	UMCC- N Connector Cable (Length: 0.25 m Quantity: 4 Pcs)	SIEMENS	--	--
5	N Connector-50 Ω Terminations (Quantity: 4 Pcs)	SIEMENS	--	--
6	SIMATIC PS 307 Power Supply (Input: AC 120 /230 V 2.3 /1.2 A 50-60 Hz) (Output: DC 24 V 5 A) (Quantity: 1 Pcs)	SIEMENS	6ES7307-1EA01-0AA0	YSU/HO 165357

4. Operation and Monitoring of the EUT during Testing

4.1. Operating Modes

The EUT was tested in the following operating mode(s):

Continuously transmitting modulated carrier with combination of

- **Maximum Power Settings** [refer section 4.3]
- **Test Channels** [refer section 3.4]
- **Worst Case* SISO and MIMO modes** [refer section 4.3]

*Multiple supported modulation schemes, nominal channel bandwidths and SISO/MIMO configurations were initially investigated to determine the above mentioned worst case data rates in terms of highest output power & widest bandwidth.

4.2. Configuration and Peripherals

The EUT was tested in the following configuration(s):

- **EUT Power Supply:**
 - For AC Conducted measurement EUT(the radio module) was mounted on Test Evaluation Board. Using Siemens SIMATIC PS 307 Power Supply, 24 V DC was supplied to this board; which in turn supplying 3.3 V DC to EUT.
 - For all conducted measurements EUT(the radio module) was mounted on Test Evaluation Board. Using Lab DC Power Supply 24 V DC was supplied to this board; which in turn supplying 3.3 V DC to EUT.
- **Test Mode Activation:**
 - For continuous transmit tests the EUT was controlled using the chipset manufacturers 'cli' console over tera-term and putty. This was run from within the terminal application on the EUT. The application was used to enable continuous transmission mode and to select the test channels, data rates and modulation schemes as required.
- **Worst Case Mode Determination:**
 - Multiple supported modulation schemes, nominal channel bandwidths and SISO+MIMO Modes configurations were initially investigated to determine worst case modes.
 - The data rates that produced worst case results for each 802.11 mode (a/n/ac) were then used for measurements presented in this report.
- **Conducted Measurements:**
 - RF Output Power, Power Spectral Density, Occupied Channel Bandwidths measured separately on each Port with all supported SISO & MIMO Port combinations.
 - Duty Cycles were computed with worst case SISO mode; as they found to be independent of number of transmitter chains used.
- **AC Conducted Emissions Measurements:**
 - AC conducted tests were performed with all listed Antennas with MIMO Port 1+2+3+4, employing maximum possible Antennas.
 - The Toyo EMI Software EP5/CE Ver 4.0.1. was used for these measurements.
- **Applicable to all Tests:**
 - All the supplied antennas listed in section 3.5 have been tested with power settings in section 4.3.
 - During testing unused EUT ports were terminated as listed in section 4.3.

4.3. Used Power Settings & Port Terminations

The EUT was configured with following GUI Power Settings (PWL), worst case data rates (in terms of highest output power & widest bandwidth) & test channels for 9 dBi Antenna configurations.

5250 MHz to 5350 MHz [U-NII-2A Band]							
9 dBi Antenna							
SISO Port 1 (Note 1)							
Nominal Channel Bandwidth	20 MHz						
Worst Case Data Rates	a-mode: 48 & 54 Mbit n-mode : MCS 2 & 6 ac-mode: MCS 2 & 6				40 MHz		
Test Channel	52	56	60	64	n-mode : MCS 3 & 4 ac-mode: MCS 3 & 4		80 MHz
PWL	17	17	17	12	54	62	ac-mode: MCS 1 & 8
	17	17	17	12	12	12	58
	17	17	17	12	12	12	12
Note 1: Unused Ports 2,3 & 4 Terminated with 50 Ω							
MIMO Port 1+2 (Note 2)							
Nominal Channel Bandwidth	20 MHz						
Worst Case Data Rates	a-mode: 48 & 54 Mbit n-mode : MCS 0 & 4 ac-mode: MCS 0 & 4				40 MHz		
Test Channel	52	56	60	64	n-mode : MCS 7 ac-mode: MCS 7		80 MHz
PWL	18	18	18	12	54	62	ac-mode: MCS 5 & 9
	18	18	18	12	12	12	58
	18	18	18	12	12	12	12
Note 2: Unused Ports 3 & 4 Terminated with 50 Ω							
MIMO Port 1+2+3 (Note 3)							
Nominal Channel Bandwidth	20 MHz						
Worst Case Data Rates	a-mode: 9 & 12 Mbit n-mode : MCS 3 & 7 ac-mode: MCS 3 & 7				40 MHz		
Test Channel	52	56	60	64	n-mode : MCS 3 & 5 ac-mode: MCS 3 & 5		80 MHz
PWL	16	16	16	13	54	62	ac-mode: MCS 1 & 2
	16	16	16	13	13	13	58
	16	16	16	13	13	13	13
Note 3: Unused Port 4 Terminated with 50 Ω							
MIMO Port 1+2+3+4 (Note 4)							
Note 4: Refer separate test report : UL-RPT-RP11909763-3616A.pdf for 9 dBi Antenna-MIMO Port 1+2+3+4 Testings.							

4.4. Used RF Cables

For AC conducted emission measurements performed with Antennas, EUT ports were connected with following RF cables to the antenna type.
 For further details refer Section 3.6.B.

Antenna Type	EUT to Antennas Cable Details
	MIMO Mode Port 1+2+3+4
9 dBi Antenna	UMCC- N Connector Cables

For all conducted measurements performed EUT ports were connected with following RF cables to the Spectrum Analyzer's RF cable.
 For further details refer Section 3.6.B.

Antenna Type	EUT to Antennas Cable Details		
	SISO Mode Port 1	MIMO Mode Port 1+2	MIMO Mode Port 1+2+3
9 dBi Antenna	UMCC- N Connector Cables		

5. Measurements, Examinations and Derived Results

5.1. General Comments

Measurement uncertainties are evaluated in accordance with current best practice. Our reported expanded uncertainties are based on standard uncertainties, which are multiplied by an appropriate coverage factor to provide a statistical confidence level of approximately 95%. Please refer to Section 6 *Measurement Uncertainty* for details.

In accordance with DAkkS requirements all the measurement equipment is on a calibration schedule. All equipment was within the calibration period on the date of testing.

5.2. Test Results

5.2.1. Transmitter AC Conducted Spurious Emissions

Test Summary:

Test Engineers:	Krume Ivanov & Bernd Woerl	Test Dates:	17 & 18 February 2020
Test Sample Serial Number:	192.168.0.70		
Test Site Identification	SR 7/8		

FCC Reference:	Part 15.207
Test Method Used:	ANSI C63.10 Section 6.2 / FCC KDB 174176 and notes below

Environmental Conditions:

Temperature (°C):	23
Relative Humidity (%):	35

Settings of the Instrument

Detector	Quasi Peak/ Average Peak
-----------------	--------------------------

Notes:

- Measurement software used: Toyo EMI Software; CE measurement software EP5/CE Ver 4.0.1.
- The EUT was powered by supplying 24 V DC via SIEMENS SIMATIC PS 307 Power Supply.
- In accordance with FCC KDB 174176 Q4; the SIEMENS SIMATIC PS 307 Power Supply was connected to 120 VAC 60 Hz single phase supply via a LISN.
- In accordance with FCC KDB 174176 Q4; the SIEMENS SIMATIC PS 307 Power Supply was connected to 240 VAC 60 Hz single phase supply via a LISN.
- AC conducted tests were performed with the EUT set to the worst case mode:
 - maximum power setting (PWL) amongst all supported SISO-MIMO modes
 - MIMO Port 1+2+3+4 employing maximum possible Antennas
 - maximum power level setting (PWL 18) | n-Mode | Data rate: MCS1 | Bandwidth: 20 MHz | Channel 56 (5280 MHz)
- Measurements were performed in shielded room (SR7/ 8 Asset Number 1603671). The EUT was placed at a height of 80 cm above the reference ground plane and in a distance of 40 cm from the vertical ground plane at the edge of the table.
- Pre-scans were performed and markers placed on the highest live and neutral measured levels. Final measurements were performed on the marker frequencies and the results entered into the tables below.
- All other emissions shown on the pre-scan plot were investigated and found to be ambient or >20 dB below the applicable limit or below the measurement system noise floor.
- The final measured value, for the given emission, in the table below incorporates the cable loss. Calculation: Level = test receiver reading + path loss (cable attenuation + correction LISN).

Transmitter AC Conducted Spurious Emissions (continued)

Test setup:

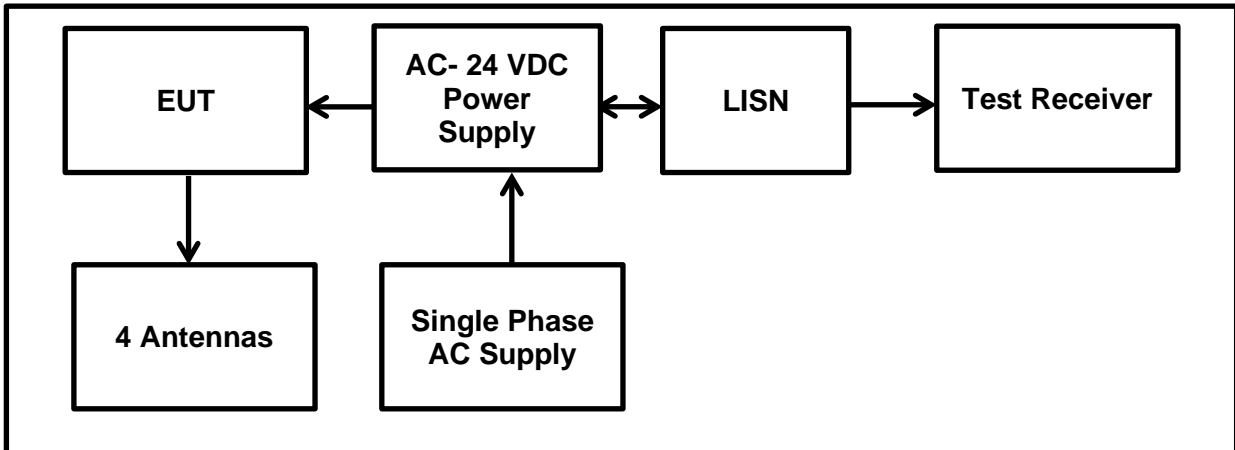

Transmitter AC Conducted Spurious Emissions (continued)

Results: Live (L1) / Quasi Peak / 120 VAC 60 Hz / 9 dBi Antenna

Frequency [MHz]	Line Phase	Reading QP [dB(μV)]	Correction Factor [dB]	Level QP [dB(μV)]	Limit QP [dB(μV)]	Margin QP [dB]	Result
0.16002	Live (L1)	31.8	9.9	41.7	65.5	23.8	Complied
0.16603	Live (L1)	31.8	9.9	41.7	65.2	23.5	Complied
0.21112	Live (L1)	29.5	9.9	39.4	63.2	23.8	Complied
0.43006	Live (L1)	23.5	9.8	33.4	57.3	23.9	Complied
3.19840	Live (L1)	22.7	9.9	32.6	56.0	23.4	Complied
3.71543	Live (L1)	19.6	9.9	29.5	56.0	26.5	Complied

Results: Live (L1) / Average / 120 VAC 60 Hz / 9 dBi Antenna

Frequency [MHz]	Line Phase	Reading AV [dB(μV)]	Correction Factor [dB]	Level AV [dB(μV)]	Limit AV [dB(μV)]	Margin AV [dB]	Result
0.16002	Live (L1)	18.2	9.9	28.1	55.5	27.4	Complied
0.16603	Live (L1)	22.6	9.9	32.5	55.2	22.7	Complied
0.21112	Live (L1)	16.2	9.9	26.1	53.2	27.1	Complied
0.43006	Live (L1)	9.6	9.8	19.5	47.3	27.8	Complied
3.19840	Live (L1)	8.6	9.9	18.5	46.0	27.5	Complied
3.71543	Live (L1)	7.3	9.9	17.2	46.0	28.8	Complied

Result: Pass

Transmitter AC Conducted Spurious Emissions (continued)

Results: Neutral (N) / Quasi Peak / 120 VAC 60 Hz / 9 dBi Antenna

Frequency [MHz]	Line Phase	Reading QP [dB(µV)]	Correction Factor [dB]	Level QP [dB(µV)]	Limit QP [dB(µV)]	Margin QP [dB]	Result
0.17154	Neutral (N)	31.8	9.9	41.7	64.9	23.2	Complied
0.19259	Neutral (N)	30.1	9.9	40.0	63.9	23.9	Complied
0.23918	Neutral (N)	28.3	9.9	38.2	62.1	23.9	Complied
0.26924	Neutral (N)	27.0	9.8	36.8	61.1	24.3	Complied
0.39299	Neutral (N)	23.3	9.9	33.2	58.0	24.8	Complied
3.19439	Neutral (N)	23.0	9.9	32.9	56.0	23.1	Complied

Results: Neutral (N) / Average / 120 VAC 60 Hz / 9 dBi Antenna

Frequency [MHz]	Line Phase	Reading AV [dB(µV)]	Correction Factor [dB]	Level AV [dB(µV)]	Limit AV [dB(µV)]	Margin AV [dB]	Result
0.17154	Neutral (N)	17.7	9.9	33.4	54.9	21.5	Complied
0.19259	Neutral (N)	15.6	9.9	26.7	53.9	27.2	Complied
0.23918	Neutral (N)	14.8	9.9	24.1	52.1	28.0	Complied
0.26924	Neutral (N)	12.6	9.8	22.7	51.1	28.4	Complied
0.39299	Neutral (N)	7.9	9.9	23.1	48.0	24.9	Complied
3.19439	Neutral (N)	11.2	9.9	18.8	46.0	27.2	Complied

Result: Pass

Transmitter AC Conducted Spurious Emissions (continued)

Plot: Live and Neutral Line / 120 VAC 60 Hz / 9 dBi Antenna

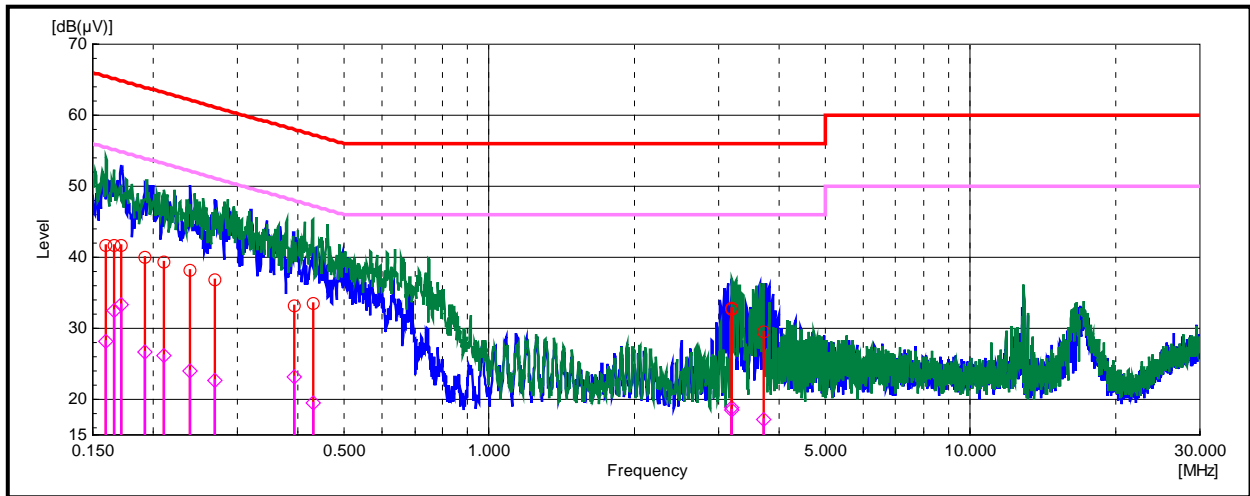

Note: The plots show the max hold (peak detector) pre-scan results measured. Blue graph represents the result of the N-Line; green graph - the results for L1-Line. The bar graphs indicate the final measurement result applying the dedicated detector at selected frequencies for each limit line (red cycle for quasi peak limit; violet cycle for average limit).

Legend (Conducted Emissions)	
Items	Description
	Blue graph is the result of peak measurement phase L
	Green graph is the result of peak measurement phase N
	Limit line Quasi-Peak
	Limit line Average
	Final item Quasi-Peak
	Final item Average

Transmitter AC Conducted Spurious Emissions (continued)

Results: Live (L1) / Quasi Peak / 240 VAC 60 Hz / 9 dBi Antenna

Frequency [MHz]	Line Phase	Reading QP [dB(µV)]	Correction Factor [dB]	Level QP [dB(µV)]	Limit QP [dB(µV)]	Margin QP [dB]	Result
0.15351	Live (L1)	29.2	9.9	39.1	65.8	26.7	Complied
0.22415	Live (L1)	26.0	9.9	35.9	62.7	26.8	Complied
0.27275	Live (L1)	24.1	9.8	33.9	61.0	27.1	Complied
3.24649	Live (L1)	17.0	9.9	26.9	56.0	29.1	Complied
3.87976	Live (L1)	21.9	9.9	31.8	56.0	24.2	Complied
12.91182	Live (L1)	24.5	10.1	34.6	60.0	25.4	Complied

Results: Live (L1) / Average / 240 VAC 60 Hz / 9 dBi Antenna

Frequency [MHz]	Line Phase	Reading AV [dB(µV)]	Correction Factor [dB]	Level AV [dB(µV)]	Limit AV [dB(µV)]	Margin AV [dB]	Result
0.15351	Live (L1)	11.5	9.9	21.4	55.8	26.7	Complied
0.22415	Live (L1)	16.8	9.9	26.7	52.7	26.8	Complied
0.27275	Live (L1)	8.1	9.8	17.9	51.0	27.1	Complied
3.24649	Live (L1)	7.7	9.9	17.6	46.0	29.1	Complied
3.87976	Live (L1)	12.9	9.9	22.8	46.0	24.2	Complied
12.91182	Live (L1)	22.4	10.1	32.5	50.0	25.4	Complied

Result: Pass

Transmitter AC Conducted Spurious Emissions (continued)

Results: Neutral (N) / Quasi Peak / 240 VAC 60 Hz / 9 dBi Antenna

Frequency [MHz]	Line Phase	Reading QP [dB(μV)]	Correction Factor [dB]	Level QP [dB(μV)]	Limit QP [dB(μV)]	Margin QP [dB]	Result
0.15501	Neutral (N)	28.4	9.9	38.3	65.7	27.4	Complied
0.17004	Neutral (N)	34.4	9.9	44.3	65.0	20.7	Complied
0.21814	Neutral (N)	25.6	9.9	35.5	62.9	27.4	Complied
0.27074	Neutral (N)	23.6	9.8	33.4	61.1	27.7	Complied
3.28657	Neutral (N)	11.0	9.9	20.9	56.0	35.1	Complied
12.91182	Neutral (N)	24.6	10.1	34.7	60.0	25.3	Complied

Results: Neutral (N) / Average / 240 VAC 60 Hz / 9 dBi Antenna

Frequency [MHz]	Line Phase	Reading AV [dB(μV)]	Correction Factor [dB]	Level AV [dB(μV)]	Limit AV [dB(μV)]	Margin AV [dB]	Result
0.15501	Neutral (N)	10.6	9.9	20.5	55.7	35.2	Complied
0.17004	Neutral (N)	21.4	9.9	31.3	55.0	23.7	Complied
0.21814	Neutral (N)	10.3	9.9	20.2	52.9	32.7	Complied
0.27074	Neutral (N)	6.9	9.8	16.7	51.1	34.4	Complied
3.28657	Neutral (N)	1.3	9.9	11.2	46.0	34.8	Complied
12.91182	Neutral (N)	22.5	10.1	32.6	50.0	17.4	Complied

Result: Pass

Transmitter AC Conducted Spurious Emissions (continued)

Plot: Live and Neutral Line / 240 VAC 60 Hz / 9 dBi Antenna

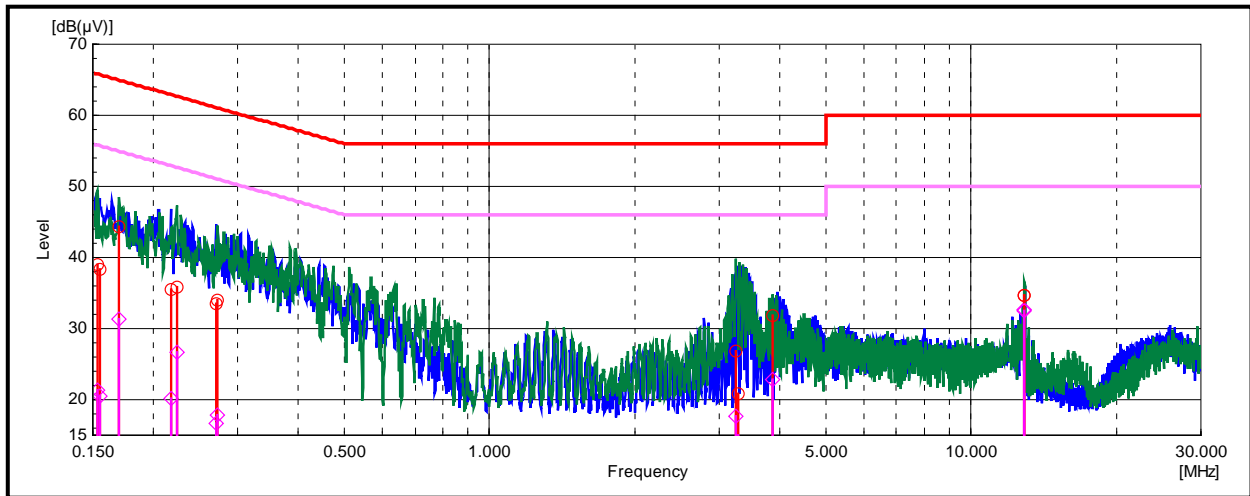

Note: The plots show the max hold (peak detector) pre-scan results measured. Blue graph represents the result of the N-Line; green graph - the results for L1-Line. The bar graphs indicate the final measurement result applying the dedicated detector at selected frequencies for each limit line (red cycle for quasi peak limit; violet cycle for average limit).

Legend (Conducted Emissions)	
Items	Description
	Blue graph is the result of peak measurement phase L
	Green graph is the result of peak measurement phase N
	Limit line Quasi-Peak
	Limit line Average
	Final item Quasi-Peak
	Final item Average

5.2.2. Transmitter 26 dB Emission Bandwidth

Test Summary:

Test Engineer:	Krume Ivanov & Sercan Usta	Test Date:	15 February 2020 to 17 February 2020
Test Sample Serial Number:	192.168.0.65		
Test Site Identification	SR 9		

FCC Reference:	Part 15.403(i)
Test Method Used:	KDB 789033 D02 Section II.C.1.

Environmental Conditions:

Temperatures (°C):	21 to 26
Relative Humidity (%):	25 to 40

Notes:

1. All configurations supported by the EUT were investigated on the one channel in accordance with KDB 789033 Section II.C.1. Emission Bandwidth (EBW) test procedure.
2. Final measurements were performed in each supported operating band using the above configurations on the bottom, middle and top or single channels.
3. 26 dB Emission Bandwidth were measured separately with worst case data rates on SISO mode & all MIMO modes.
4. The RF port on the EUT was connected to the spectrum analyser using suitable attenuation and RF cable. The measured values takes into consideration the external attenuation correction factors which is compensated by adding reference level offset of 26.80 dB @ 5.25-5.35 GHz to each of the conducted plots.

Transmitter 26 dB Emission Bandwidth (continued)

Test setup:

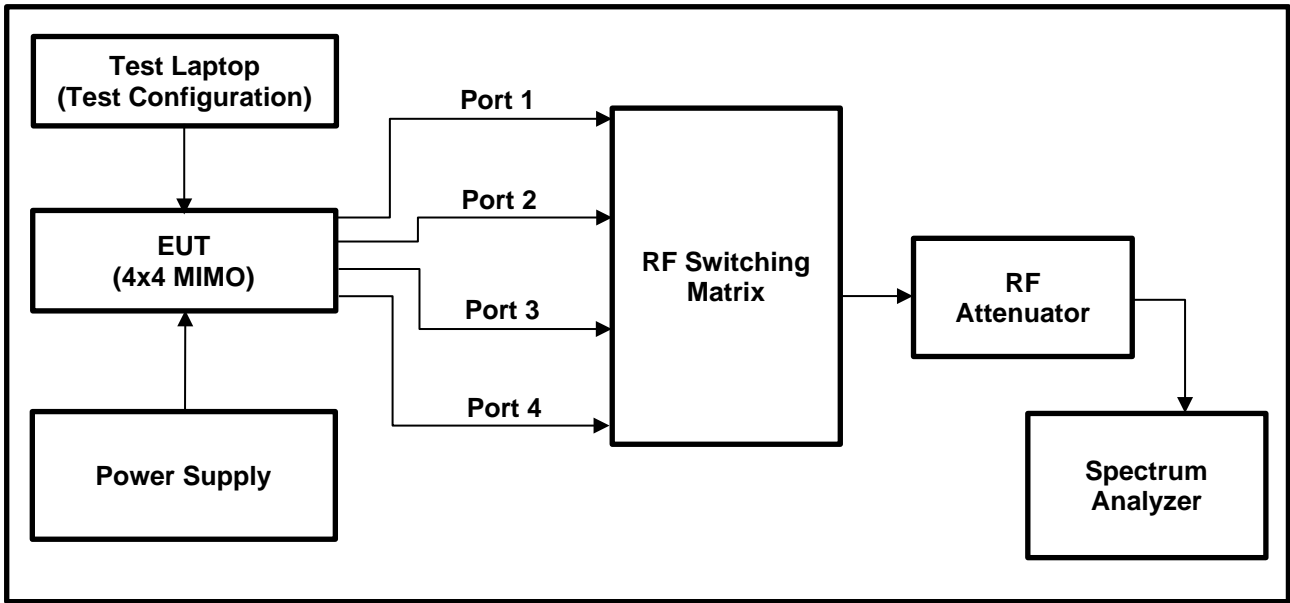

Transmitter 26 dB Emission Bandwidth (continued)

Results: 802.11a / 20 MHz / 48Mbit / SISO / Port 1 / Port 1 / PWL 17 / 9 dBi Antenna

Channel	Frequency (MHz)	26 dB Emission Bandwidth (MHz)
Bottom	5260	21.047
Middle	5280	20.964
Top-1	5300	20.62

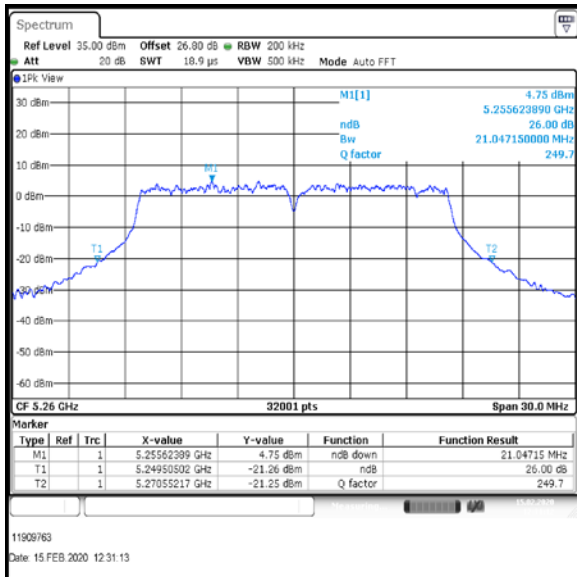

Bottom Channel

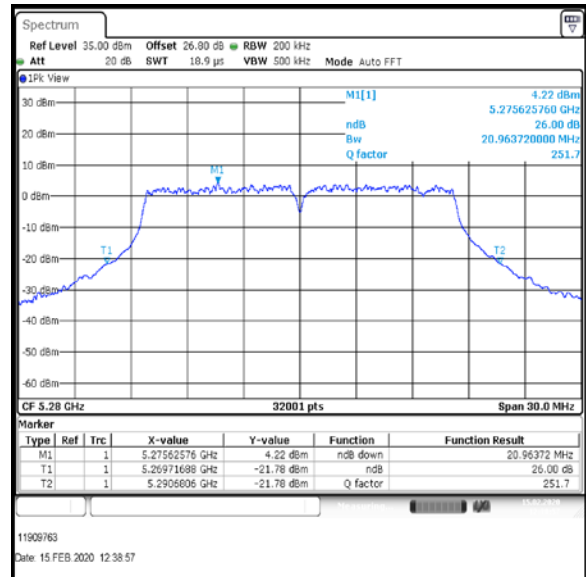

Middle Channel

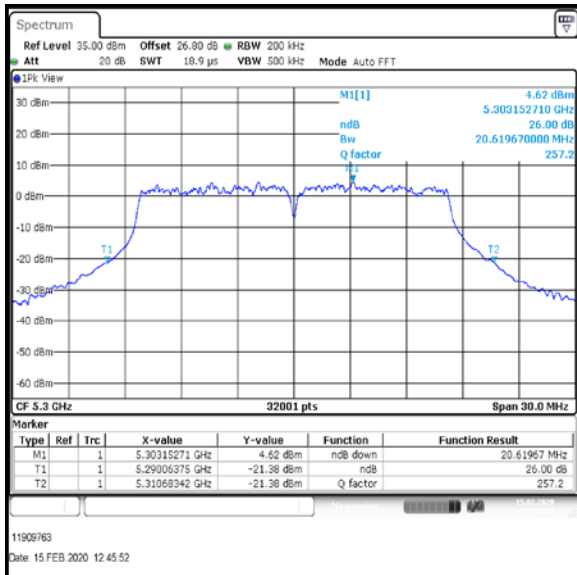

Top-1 Channel

Result: **Pass**

Transmitter 26 dB Emission Bandwidth (continued)

Results: 802.11a / 20 MHz / 48Mbit / SISO / Port 1 / Port 1 / PWL 12 / 9 dBi Antenna

Channel	Frequency (MHz)	26 dB Emission Bandwidth (MHz)
Top	5320	20.492

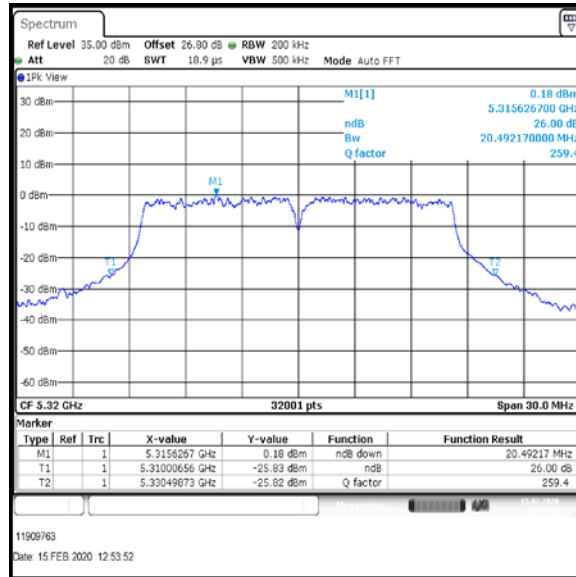

Top Channel

Result: **Pass**

Transmitter 26 dB Emission Bandwidth (continued)

Results: 802.11a / 20 MHz / 54Mbit / SISO / Port 1 / Port 1 / PWL 17 / 9 dBi Antenna

Channel	Frequency (MHz)	26 dB Emission Bandwidth (MHz)
Bottom	5260	21.087
Middle	5280	20.793
Top-1	5300	20.848

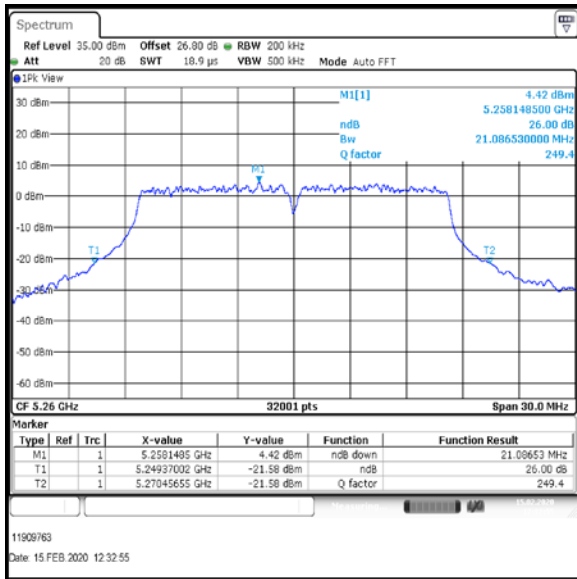

Bottom Channel

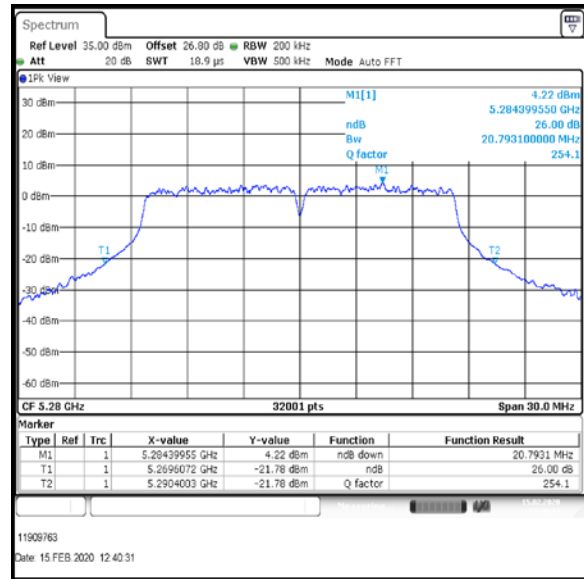

Middle Channel

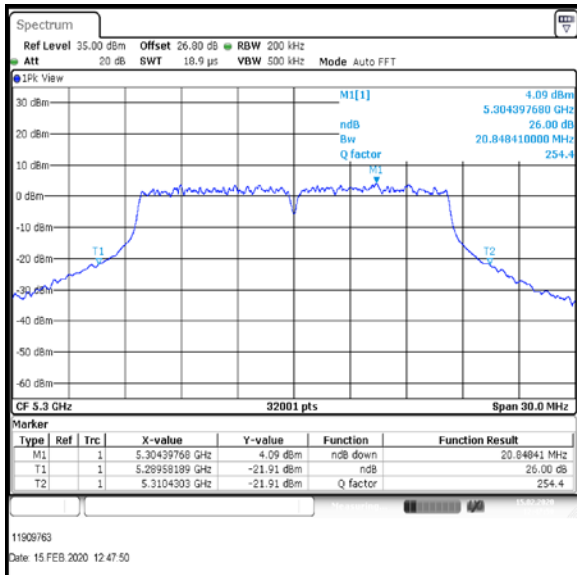

Top-1 Channel

Result: **Pass**

Transmitter 26 dB Emission Bandwidth (continued)

Results: 802.11a / 20 MHz / 54Mbit / SISO / Port 1 / Port 1 / PWL 12 / 9 dBi Antenna

Channel	Frequency (MHz)	26 dB Emission Bandwidth (MHz)
Top	5320	20.783

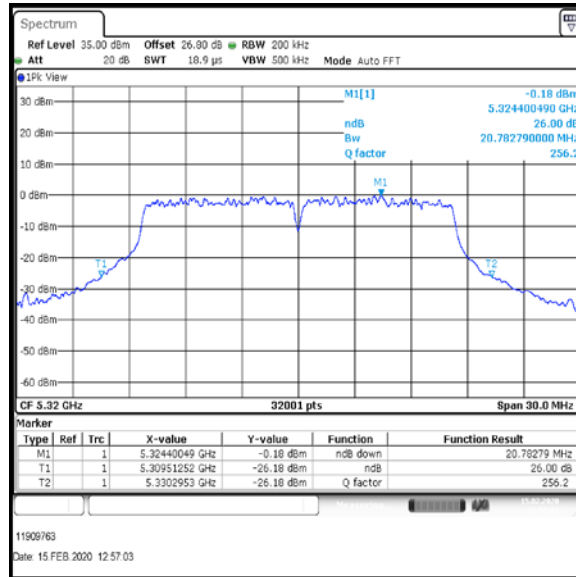

Top Channel

Result: **Pass**

Transmitter 26 dB Emission Bandwidth (continued)

Results: 802.11n / HT20 / MCS2 / SISO / Port 1 / Port 1 / PWL 17 / 9 dBi Antenna

Channel	Frequency (MHz)	26 dB Emission Bandwidth (MHz)
Bottom	5260	20.166
Middle	5280	20.11
Top-1	5300	20.092

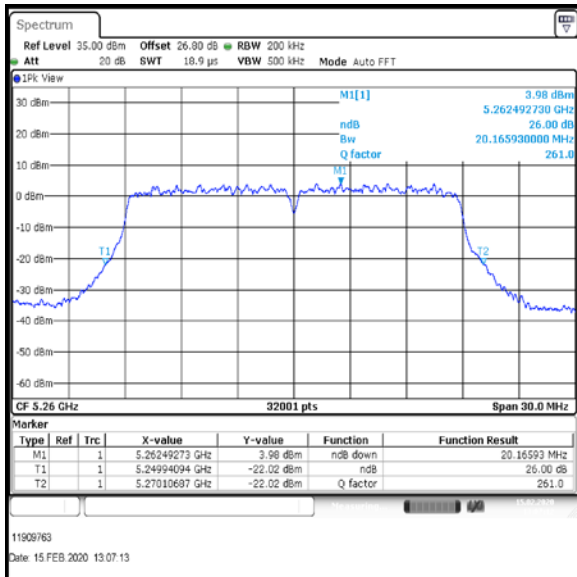

Bottom Channel

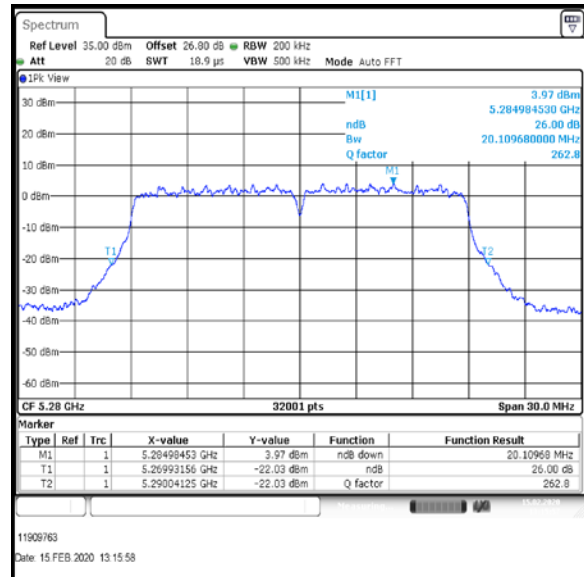

Middle Channel

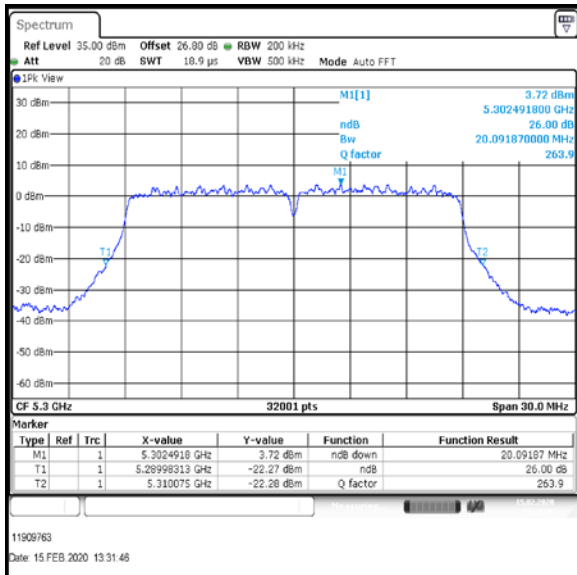

Top-1 Channel

Result: **Pass**

Transmitter 26 dB Emission Bandwidth (continued)

Results: 802.11n / HT20 / MCS2 / SISO / Port 1 / Port 1 / PWL 12 / 9 dBi Antenna

Channel	Frequency (MHz)	26 dB Emission Bandwidth (MHz)
Top	5320	20.046

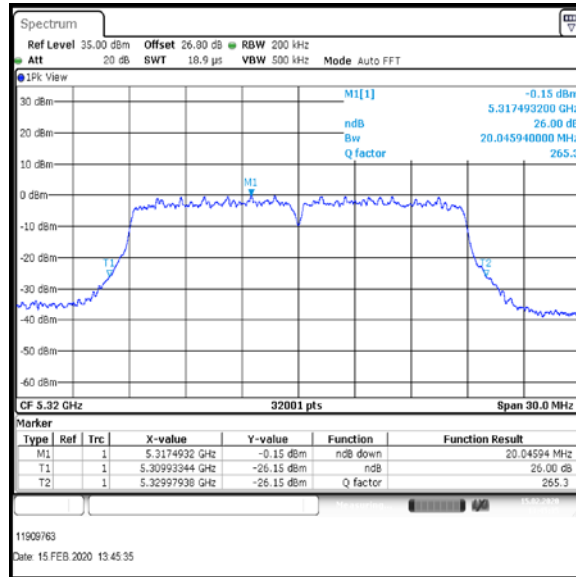

Top Channel

Result: **Pass**

Transmitter 26 dB Emission Bandwidth (continued)

Results: 802.11n / HT20 / MCS6 / SISO / Port 1 / Port 1 / PWL 17 / 9 dBi Antenna

Channel	Frequency (MHz)	26 dB Emission Bandwidth (MHz)
Bottom	5260	21.438
Middle	5280	21.26
Top-1	5300	22.383

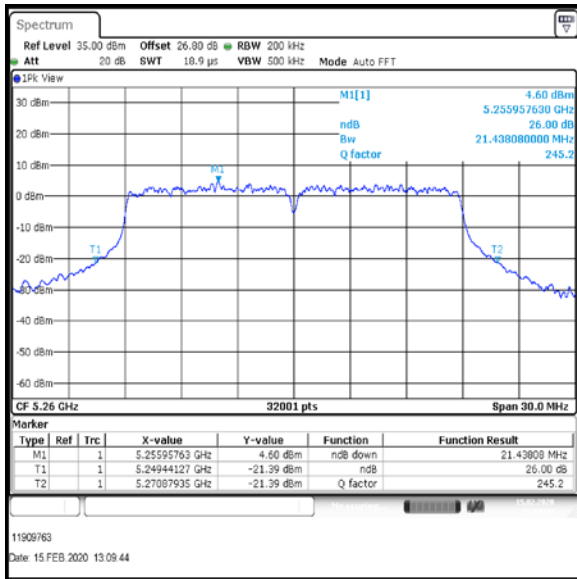

Bottom Channel

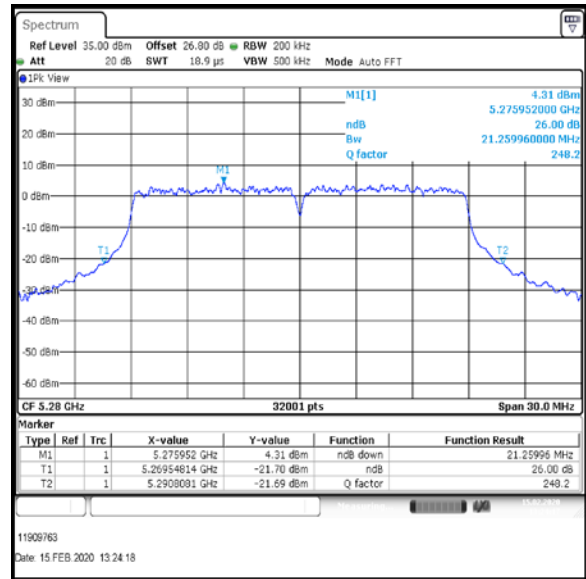

Middle Channel

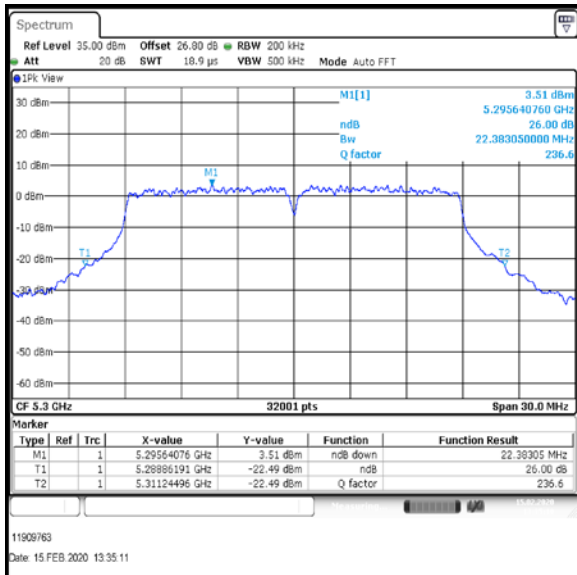

Top-1 Channel

Result: **Pass**

Transmitter 26 dB Emission Bandwidth (continued)

Results: 802.11n / HT20 / MCS6 / SISO / Port 1 / Port 1 / PWL 12 / 9 dBi Antenna

Channel	Frequency (MHz)	26 dB Emission Bandwidth (MHz)
Top	5320	21.227

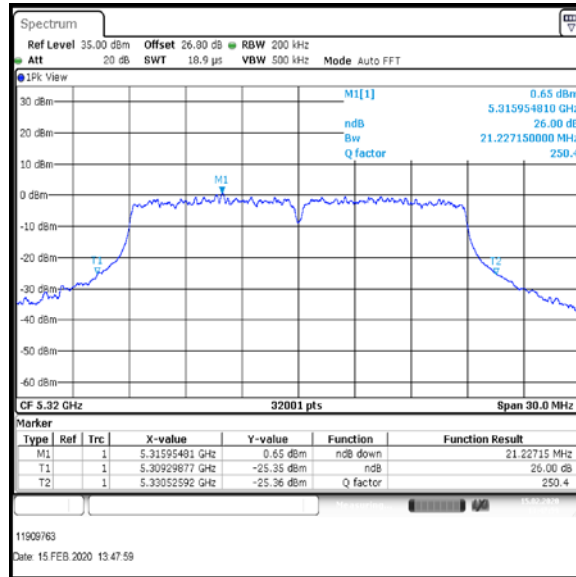

Top Channel

Result: **Pass**

Transmitter 26 dB Emission Bandwidth (continued)

Results: 802.11ac / HT20 / MCS2 / SISO / Port 1 / Port 1 / PWL 17 / 9 dBi Antenna

Channel	Frequency (MHz)	26 dB Emission Bandwidth (MHz)
Bottom	5260	20.038
Middle	5280	19.964
Top-1	5300	20.077

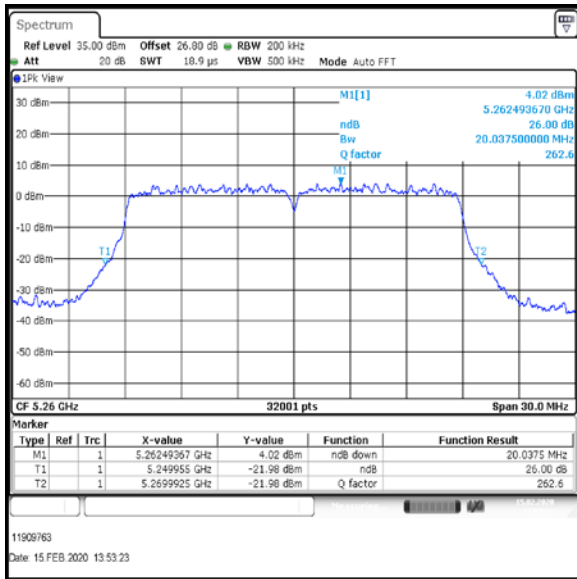

Bottom Channel

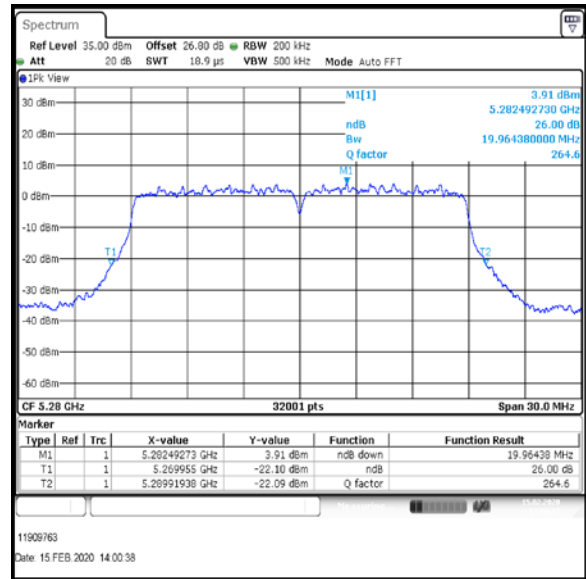

Middle Channel

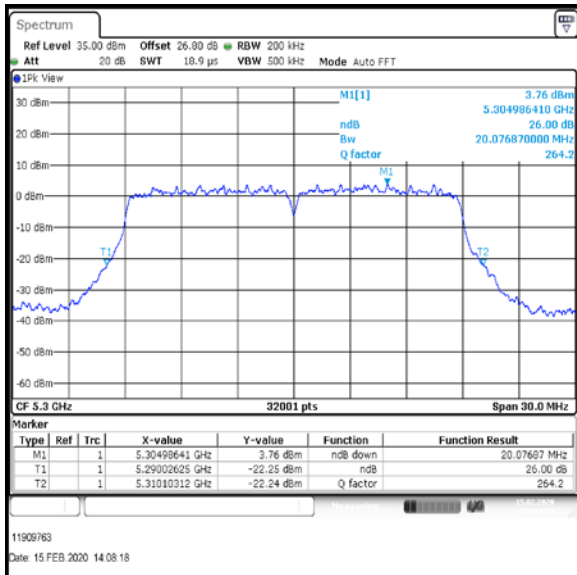

Top-1 Channel

Result: **Pass**

Transmitter 26 dB Emission Bandwidth (continued)

Results: 802.11ac / HT20 / MCS2 / SISO / Port 1 / Port 1 / PWL 12 / 9 dBi Antenna

Channel	Frequency (MHz)	26 dB Emission Bandwidth (MHz)
Top	5320	20.019

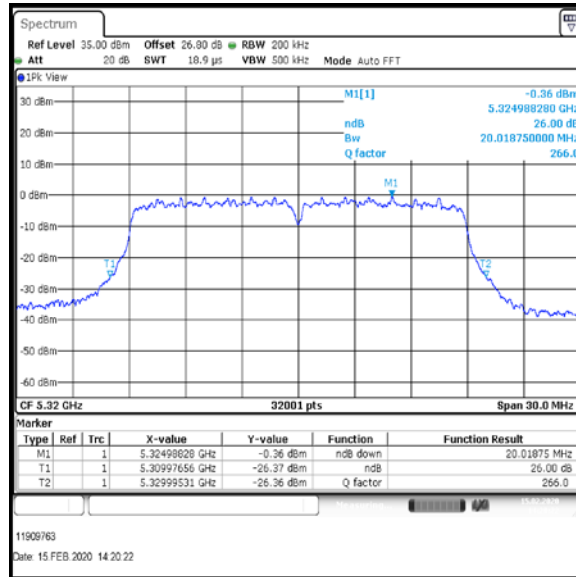

Top Channel

Result: **Pass**

Transmitter 26 dB Emission Bandwidth (continued)

Results: 802.11ac / HT20 / MCS6 / SISO / Port 1 / Port 1 / PWL 17 / 9 dBi Antenna

Channel	Frequency (MHz)	26 dB Emission Bandwidth (MHz)
Bottom	5260	21.939
Middle	5280	21.544
Top-1	5300	21.79

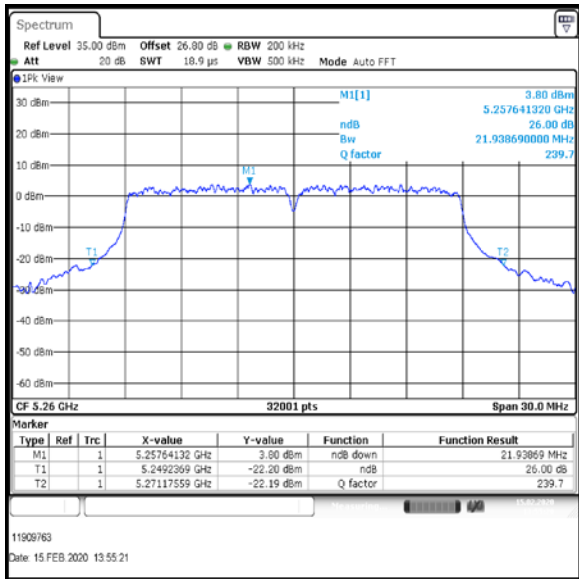

Bottom Channel

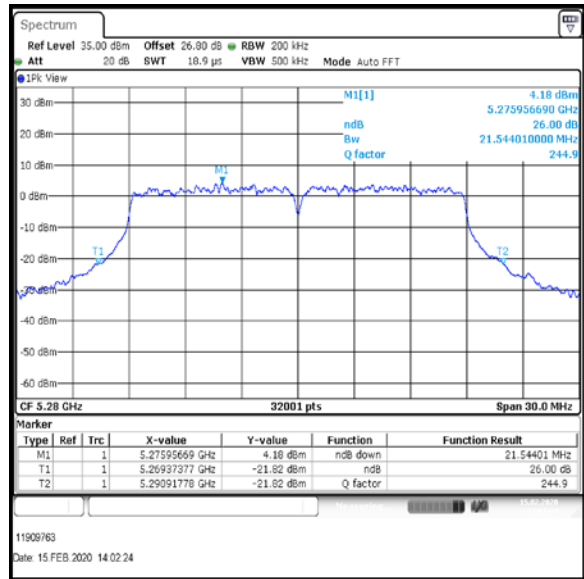

Middle Channel

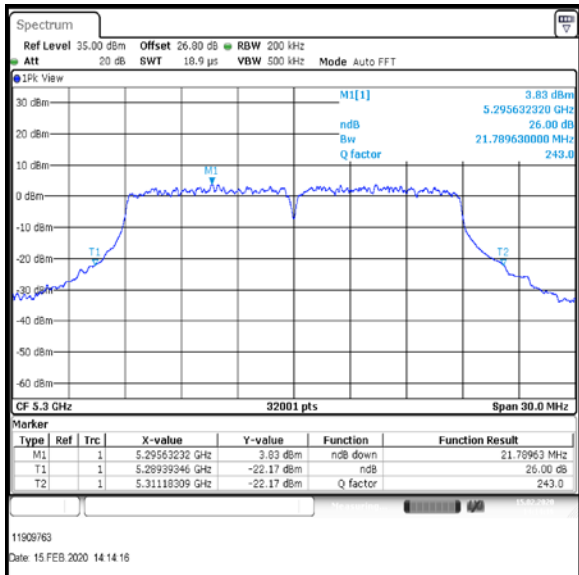

Top-1 Channel

Result: **Pass**

Transmitter 26 dB Emission Bandwidth (continued)

Results: 802.11ac / HT20 / MCS6 / SISO / Port 1 / Port 1 / PWL 12 / 9 dBi Antenna

Channel	Frequency (MHz)	26 dB Emission Bandwidth (MHz)
Top	5320	22.049

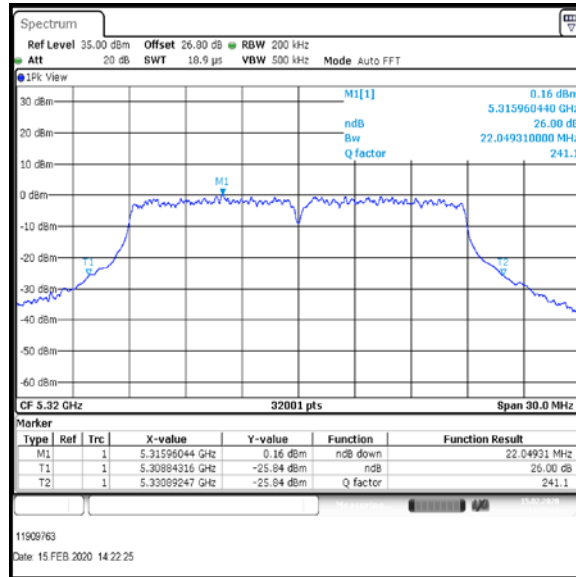

Top Channel

Result: **Pass**

Transmitter 26 dB Emission Bandwidth (continued)

Results: 802.11n / HT40 / MCS3 / SISO / Port 1 / Port 1 / PWL 12 / 9 dBi Antenna

Channel	Frequency (MHz)	26 dB Emission Bandwidth (MHz)
Bottom	5270	42.914
Top	5310	43.114

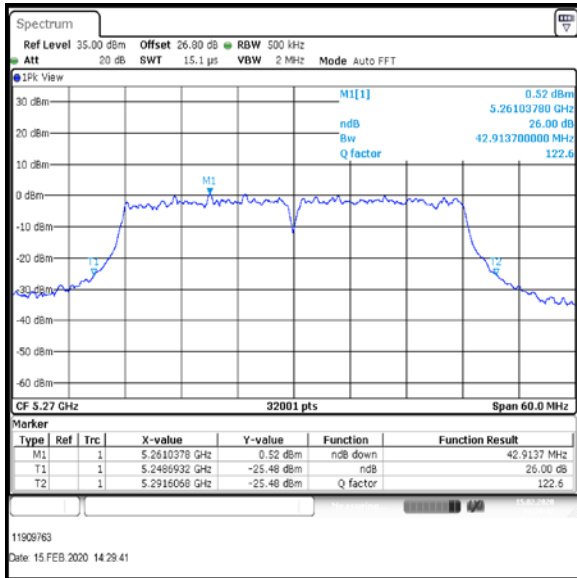

Bottom Channel

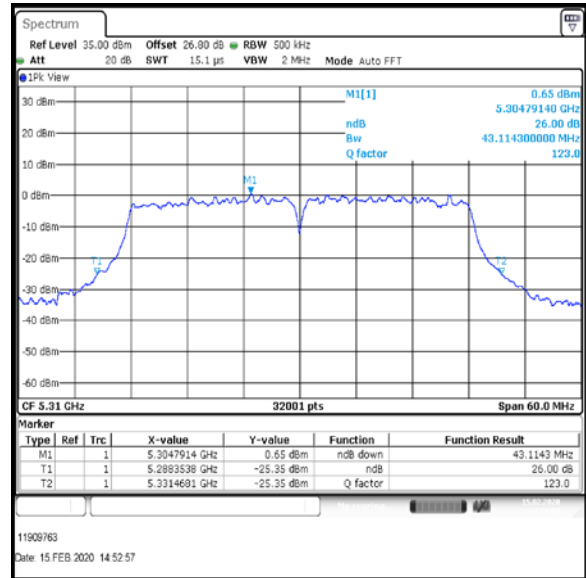

Top Channel

Result: **Pass**

Transmitter 26 dB Emission Bandwidth (continued)

Results: 802.11n / HT40 / MCS4 / SISO / Port 1 / Port 1 / PWL 12 / 9 dBi Antenna

Channel	Frequency (MHz)	26 dB Emission Bandwidth (MHz)
Bottom	5270	43.879
Top	5310	42.833

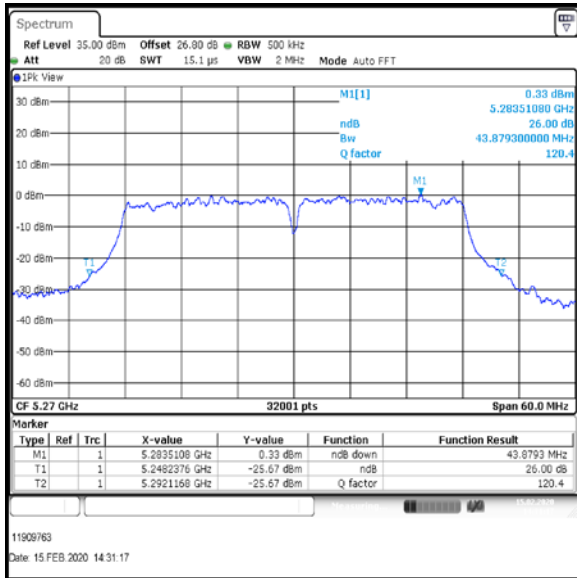

Bottom Channel

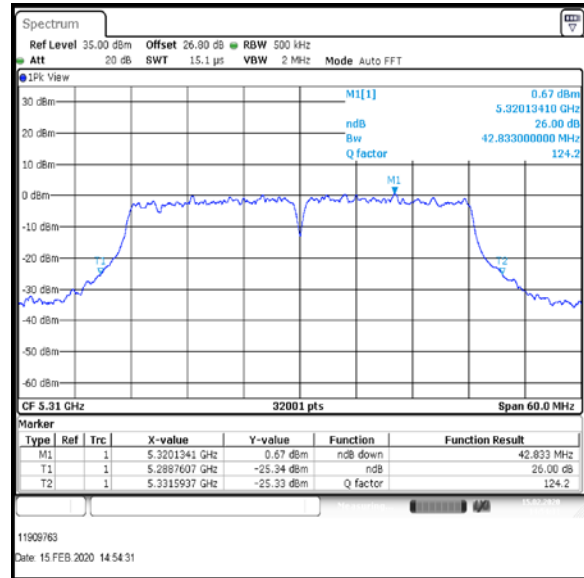

Top Channel

Result: Pass

Transmitter 26 dB Emission Bandwidth (continued)

Results: 802.11ac / HT40 / MCS3 / SISO / Port 1 / Port 1 / PWL 12 / 9 dBi Antenna

Channel	Frequency (MHz)	26 dB Emission Bandwidth (MHz)
Bottom	5270	43.028
Top	5310	44.194

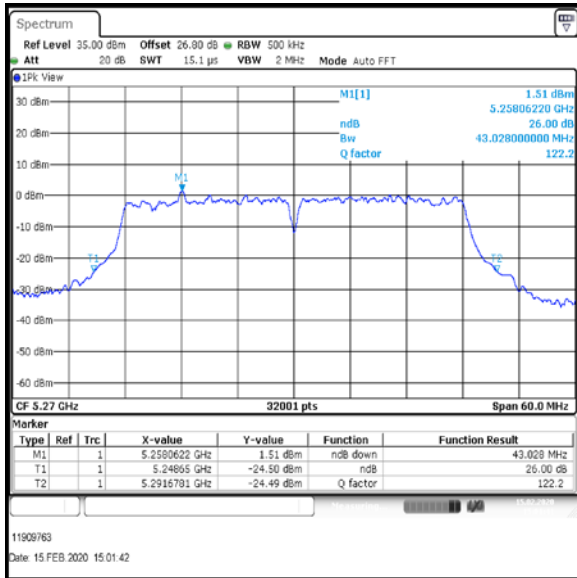

Bottom Channel

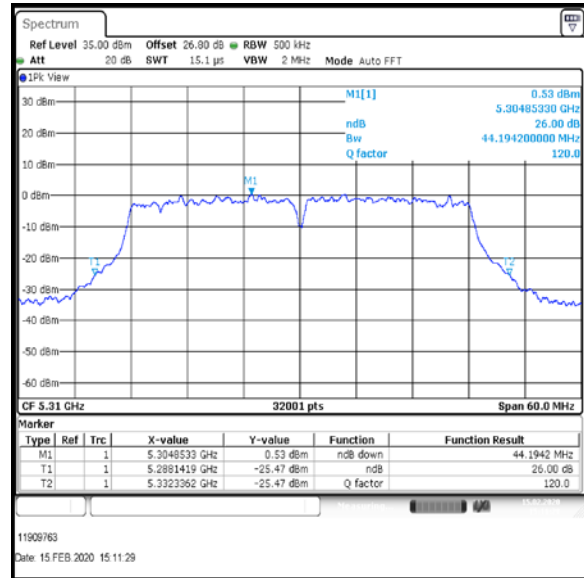

Top Channel

Result: **Pass**

Transmitter 26 dB Emission Bandwidth (continued)

Results: 802.11ac / HT40 / MCS4 / SISO / Port 1 / Port 1 / PWL 12 / 9 dBi Antenna

Channel	Frequency (MHz)	26 dB Emission Bandwidth (MHz)
Bottom	5270	44.087
Top	5310	42.987

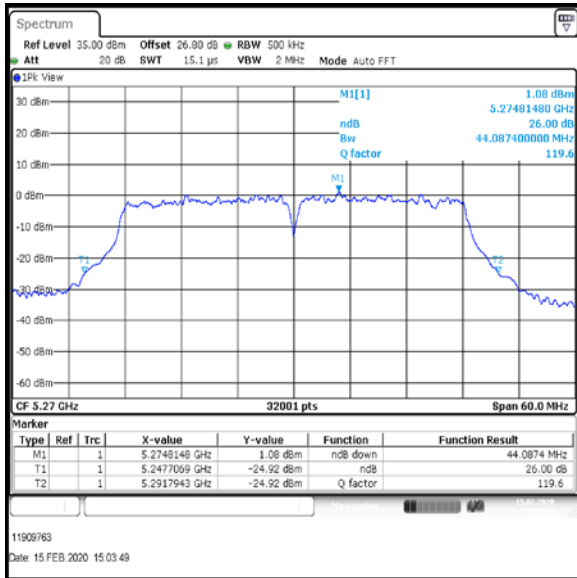

Bottom Channel

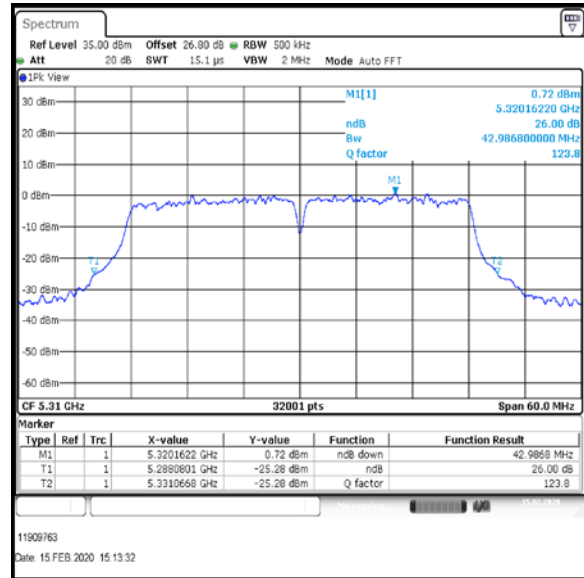

Top Channel

Result: **Pass**

Transmitter 26 dB Emission Bandwidth (continued)

Results: 802.11ac / HT80 / MCS1 / SISO / Port 1 / Port 1 / PWL 12 / 9 dBi Antenna

Channel	Frequency (MHz)	26 dB Emission Bandwidth (MHz)
Single	5290	83.814

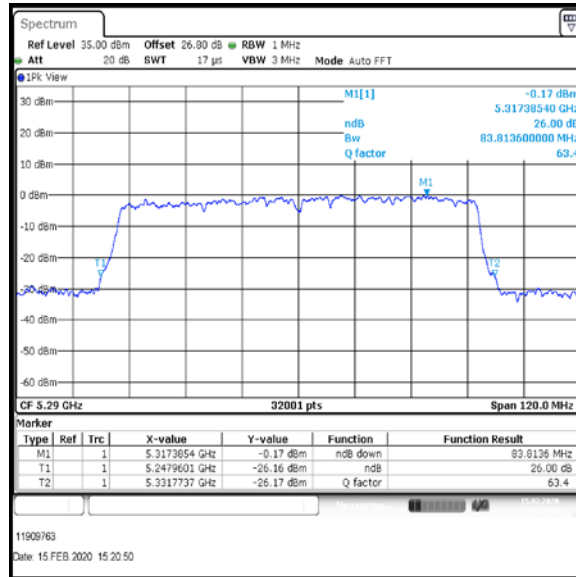

Single Channel

Result: **Pass**

Transmitter 26 dB Emission Bandwidth (continued)

Results: 802.11ac / HT80 / MCS8 / SISO / Port 1 / Port 1 / PWL 12 / 9 dBi Antenna

Channel	Frequency (MHz)	26 dB Emission Bandwidth (MHz)
Single	5290	88.782

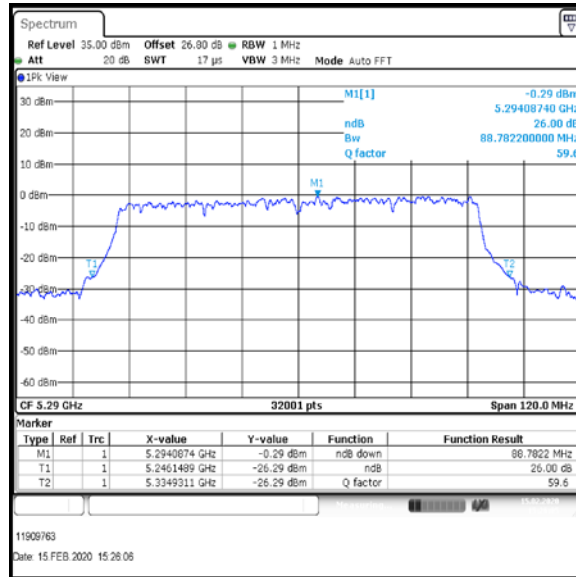

Single Channel

Result: **Pass**

Transmitter 26 dB Emission Bandwidth (continued)

Results: 802.11a / 20 MHz / 48Mbit / MIMO / Port 1+2 / Port 1 / PWL 18 / 9 dBi Antenna

Channel	Frequency (MHz)	26 dB Emission Bandwidth (MHz)
Bottom	5260	20.476
Middle	5280	20.893
Top-1	5300	21.043

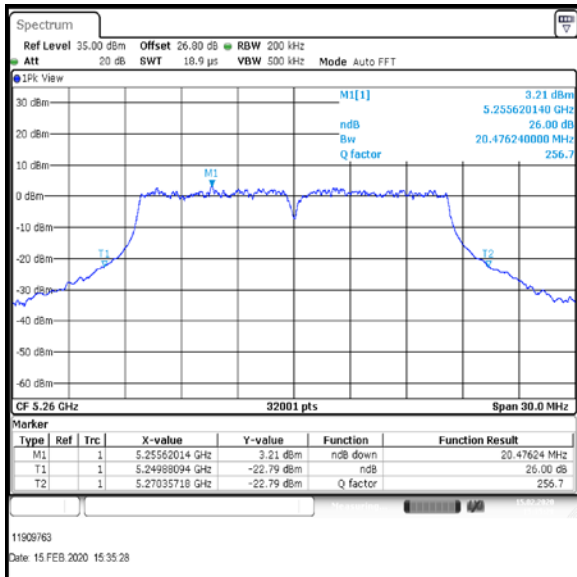

Bottom Channel

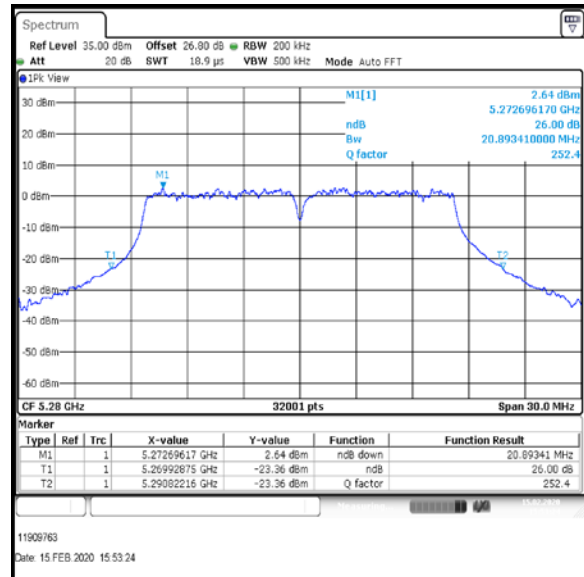

Middle Channel

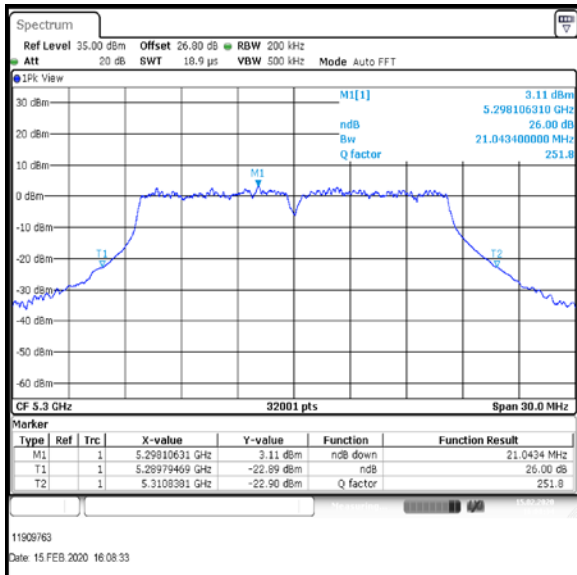

Top-1 Channel

Result: **Pass**

Transmitter 26 dB Emission Bandwidth (continued)

Results: 802.11a / 20 MHz / 48Mbit / MIMO / Port 1+2 / Port 2 / PWL 18 / 9 dBi Antenna

Channel	Frequency (MHz)	26 dB Emission Bandwidth (MHz)
Bottom	5260	20.994
Middle	5280	20.713
Top-1	5300	20.607

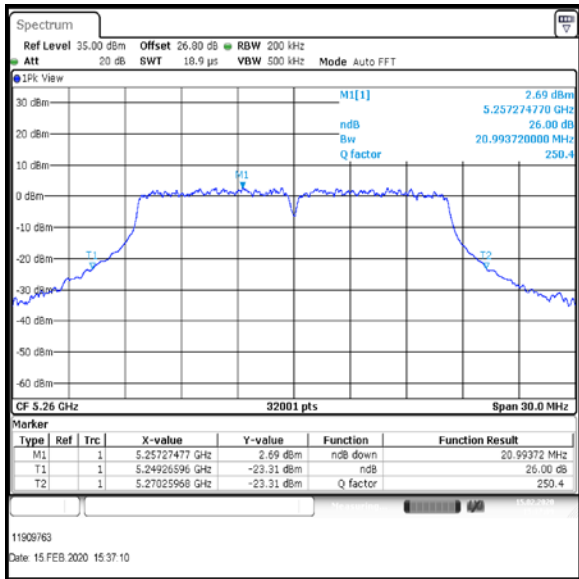

Bottom Channel

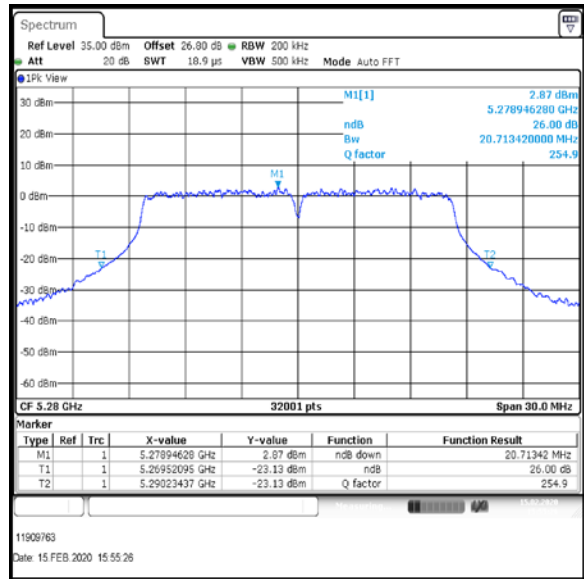

Middle Channel

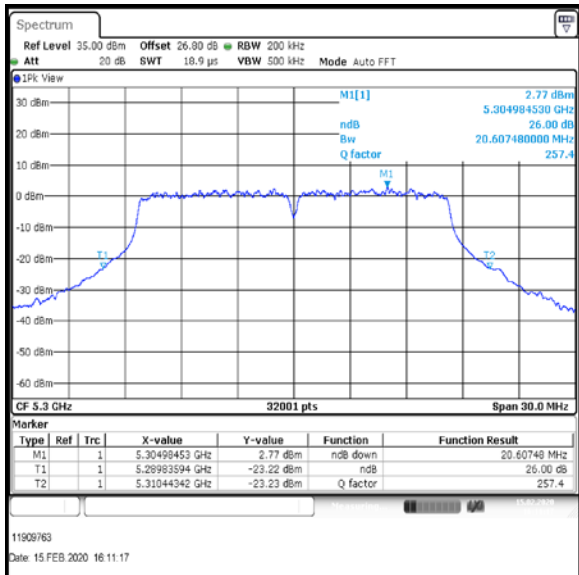

Top-1 Channel

Result: **Pass**

Transmitter 26 dB Emission Bandwidth (continued)

Results: 802.11a / 20 MHz / 48Mbit / MIMO / Port 1+2 / Port 1 / PWL 12 / 9 dBi Antenna

Channel	Frequency (MHz)	26 dB Emission Bandwidth (MHz)
Top	5320	20.672

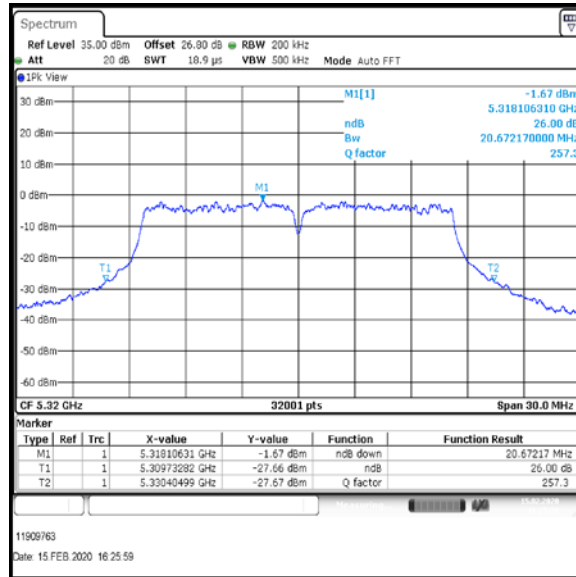

Top Channel

Result: **Pass**

Transmitter 26 dB Emission Bandwidth (continued)

Results: 802.11a / 20 MHz / 48Mbit / MIMO / Port 1+2 / Port 2 / PWL 12 / 9 dBi Antenna

Channel	Frequency (MHz)	26 dB Emission Bandwidth (MHz)
Top	5320	20.655

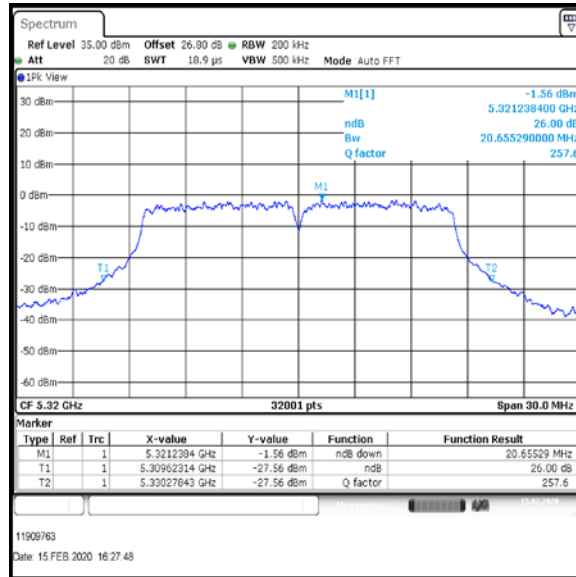

Top Channel

Result: **Pass**

Transmitter 26 dB Emission Bandwidth (continued)

Results: 802.11a / 20 MHz / 54Mbit / MIMO / Port 1+2 / Port 1 / PWL 18 / 9 dBi Antenna

Channel	Frequency (MHz)	26 dB Emission Bandwidth (MHz)
Bottom	5260	21.081
Middle	5280	20.887
Top-1	5300	20.675

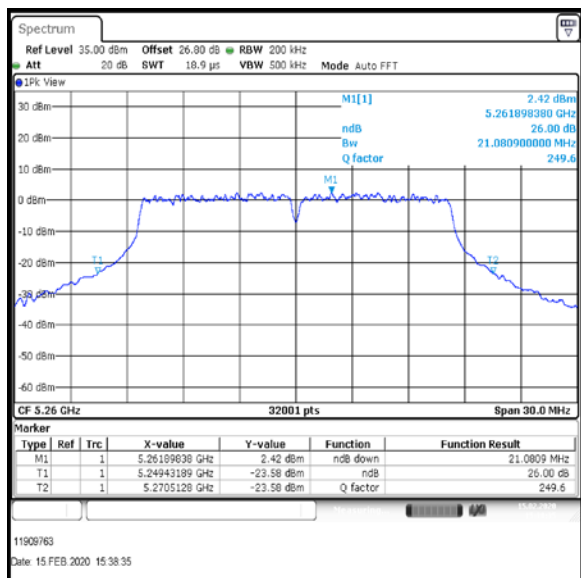

Bottom Channel

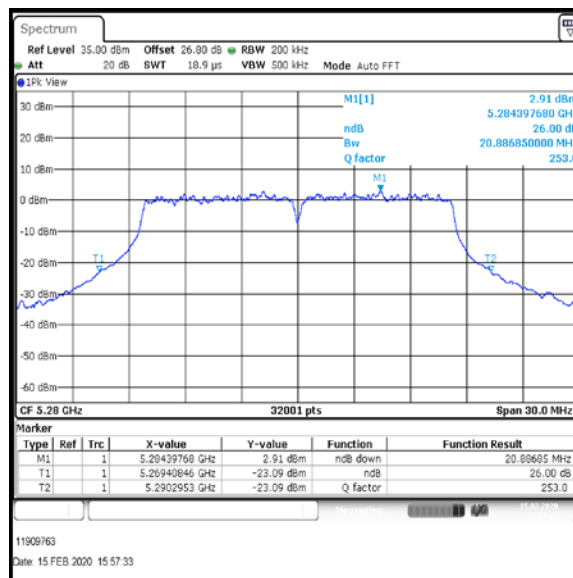

Middle Channel

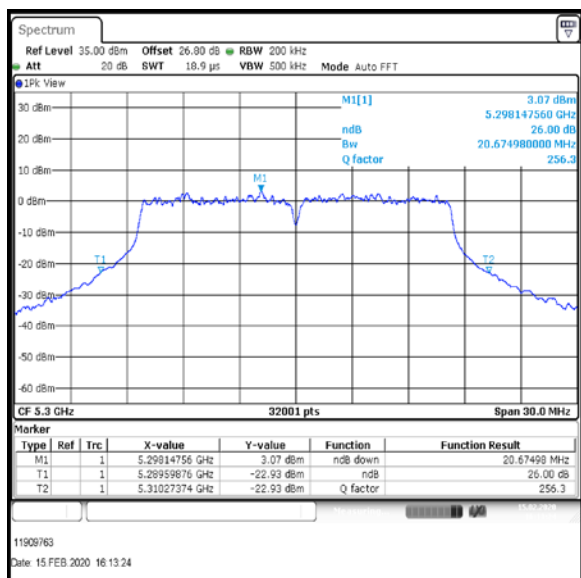

Top-1 Channel

Result: **Pass**

Transmitter 26 dB Emission Bandwidth (continued)

Results: 802.11a / 20 MHz / 54Mbit / MIMO / Port 1+2 / Port 2 / PWL 18 / 9 dBi Antenna

Channel	Frequency (MHz)	26 dB Emission Bandwidth (MHz)
Bottom	5260	20.522
Middle	5280	20.442
Top-1	5300	20.415

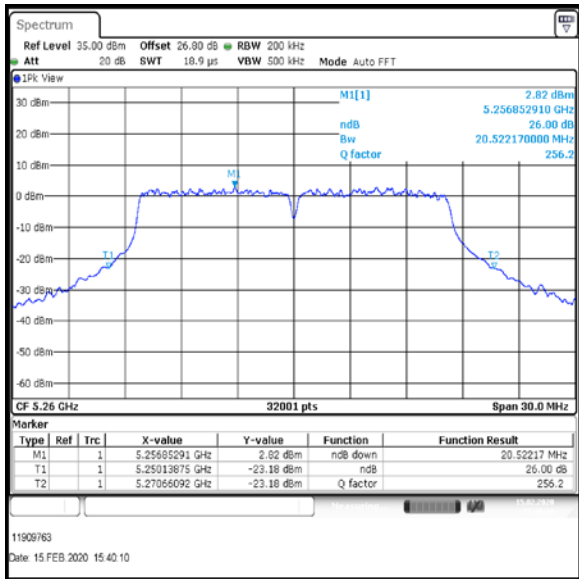

Bottom Channel

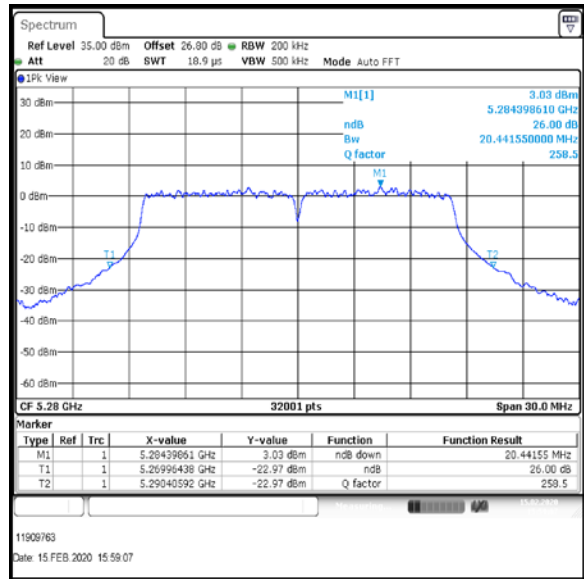

Middle Channel

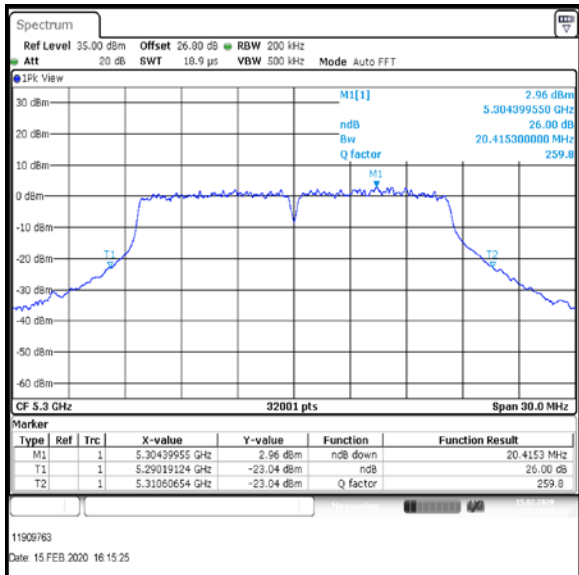

Top-1 Channel

Result: **Pass**

Transmitter 26 dB Emission Bandwidth (continued)

Results: 802.11a / 20 MHz / 54Mbit / MIMO / Port 1+2 / Port 1 / PWL 12 / 9 dBi Antenna

Channel	Frequency (MHz)	26 dB Emission Bandwidth (MHz)
Top	5320	20.996

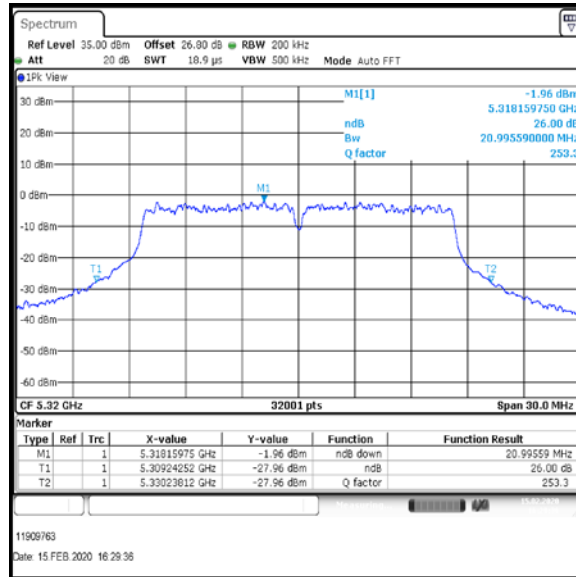

Top Channel

Result: **Pass**

Transmitter 26 dB Emission Bandwidth (continued)

Results: 802.11a / 20 MHz / 54Mbit / MIMO / Port 1+2 / Port 2 / PWL 12 / 9 dBi Antenna

Channel	Frequency (MHz)	26 dB Emission Bandwidth (MHz)
Top	5320	21.001

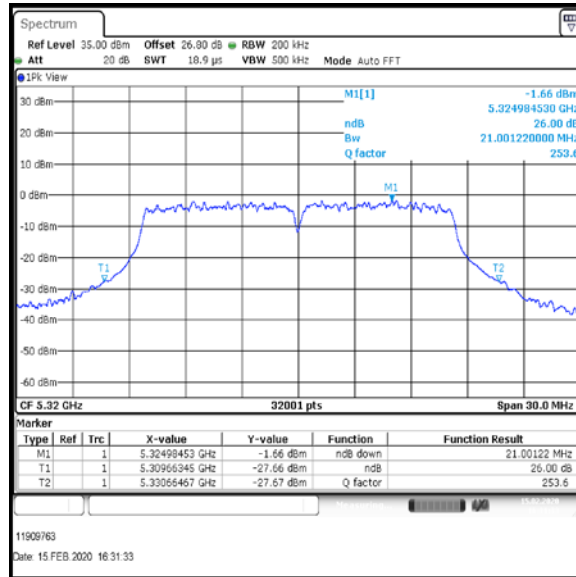

Top Channel

Result: **Pass**

Transmitter 26 dB Emission Bandwidth (continued)

Results: 802.11n / HT20 / MCS0 / MIMO / Port 1+2 / Port 1 / PWL 18 / 9 dBi Antenna

Channel	Frequency (MHz)	26 dB Emission Bandwidth (MHz)
Bottom	5260	20.322
Middle	5280	20.181
Top-1	5300	20.193

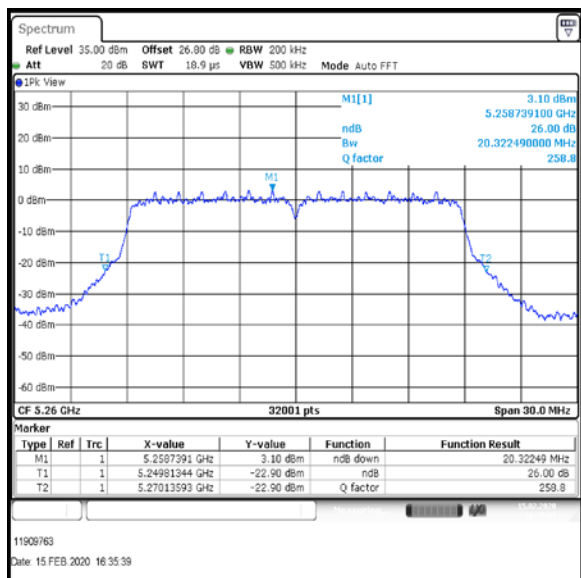

Bottom Channel

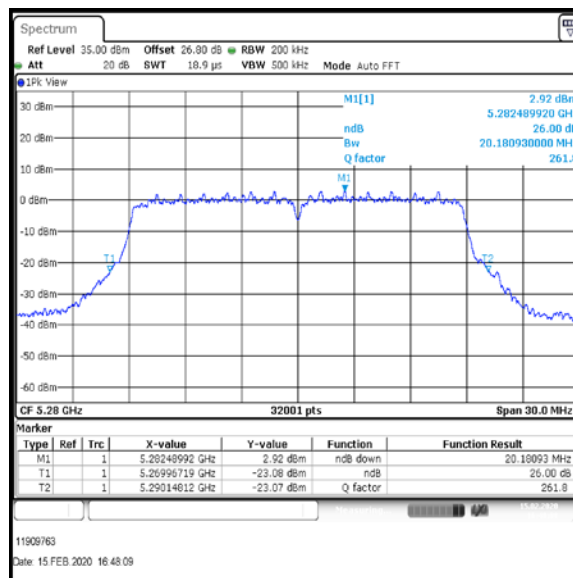

Middle Channel

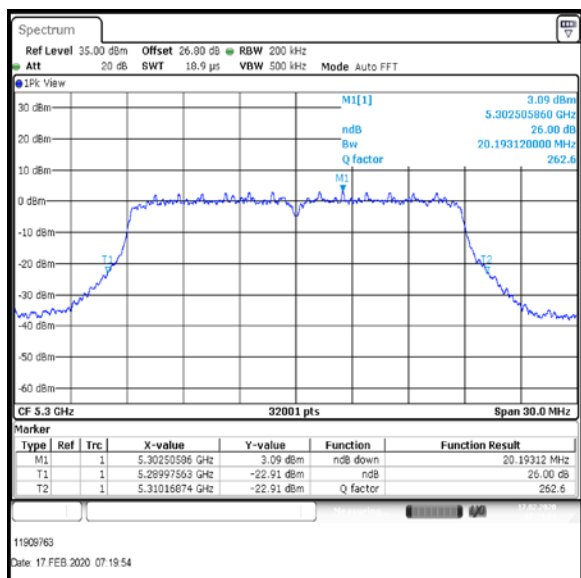

Top-1 Channel

Result: **Pass**

Transmitter 26 dB Emission Bandwidth (continued)

Results: 802.11n / HT20 / MCS0 / MIMO / Port 1+2 / Port 2 / PWL 18 / 9 dBi Antenna

Channel	Frequency (MHz)	26 dB Emission Bandwidth (MHz)
Bottom	5260	20.32
Middle	5280	20.267
Top-1	5300	19.995

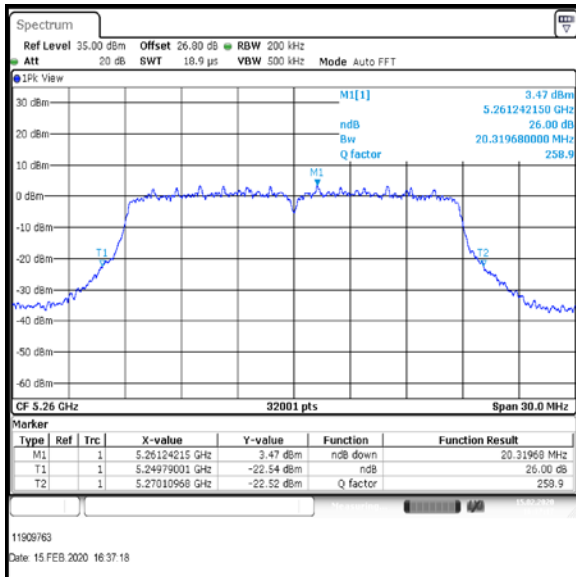

Bottom Channel

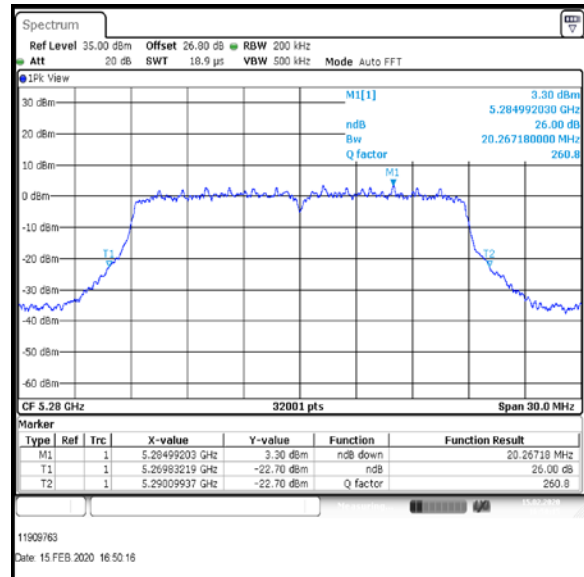

Middle Channel

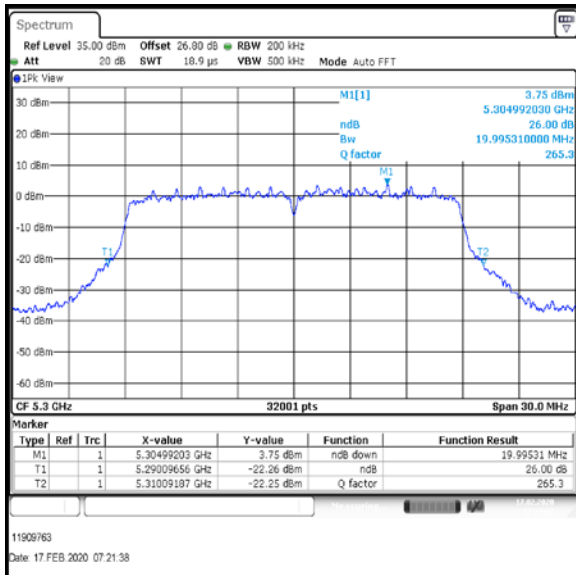

Top-1 Channel

Result: **Pass**

Transmitter 26 dB Emission Bandwidth (continued)

Results: 802.11n / HT20 / MCS0 / MIMO / Port 1+2 / Port 1 / PWL 12 / 9 dBi Antenna

Channel	Frequency (MHz)	26 dB Emission Bandwidth (MHz)
Top	5320	20.335

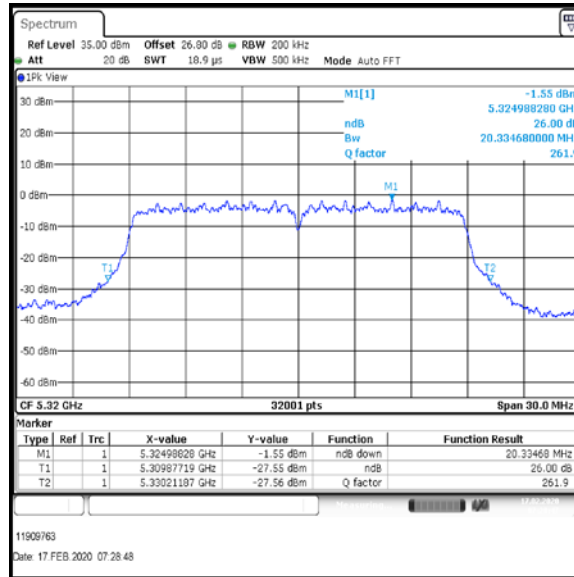

Top Channel

Result: **Pass**

Transmitter 26 dB Emission Bandwidth (continued)

Results: 802.11n / HT20 / MCS0 / MIMO / Port 1+2 / Port 2 / PWL 12 / 9 dBi Antenna

Channel	Frequency (MHz)	26 dB Emission Bandwidth (MHz)
Top	5320	20.292

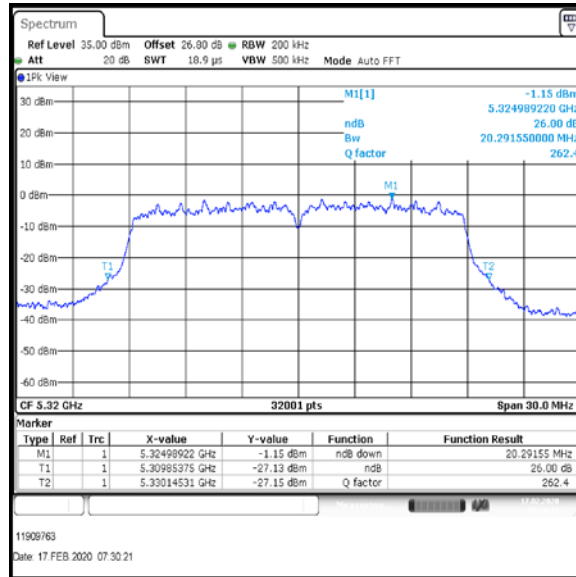

Top Channel

Result: **Pass**

Transmitter 26 dB Emission Bandwidth (continued)

Results: 802.11n / HT20 / MCS4 / MIMO / Port 1+2 / Port 1 / PWL 18 / 9 dBi Antenna

Channel	Frequency (MHz)	26 dB Emission Bandwidth (MHz)
Bottom	5260	22.779
Middle	5280	22.36
Top-1	5300	22.577

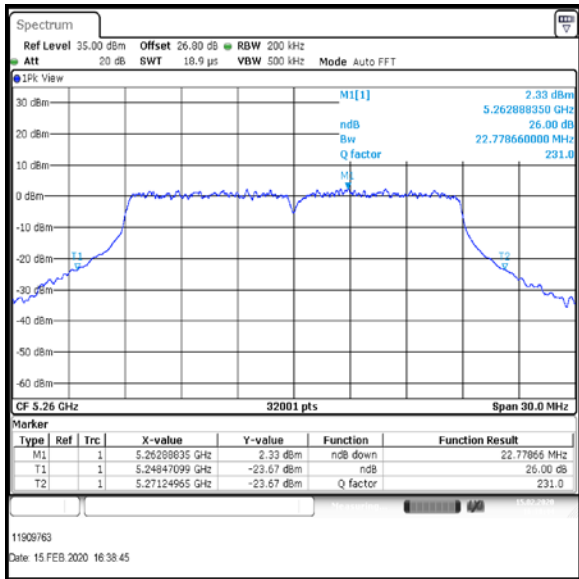

Bottom Channel

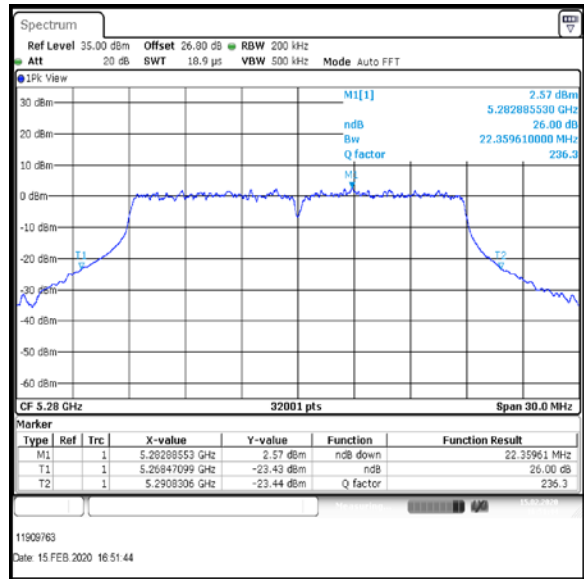

Middle Channel

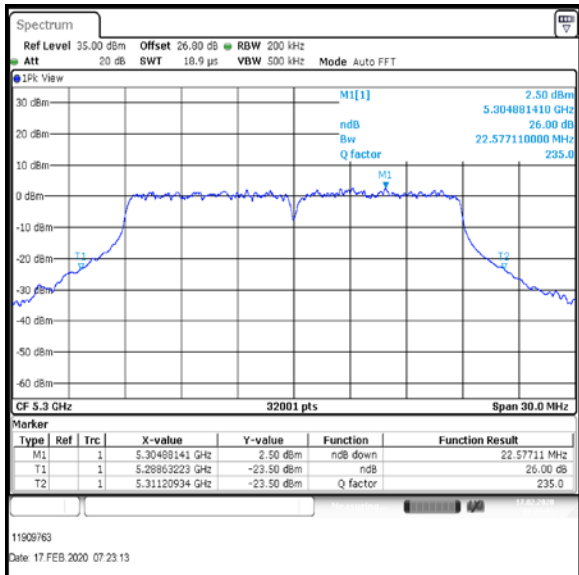

Top-1 Channel

Result: **Pass**

Transmitter 26 dB Emission Bandwidth (continued)

Results: 802.11n / HT20 / MCS4 / MIMO / Port 1+2 / Port 2 / PWL 18 / 9 dBi Antenna

Channel	Frequency (MHz)	26 dB Emission Bandwidth (MHz)
Bottom	5260	21.842
Middle	5280	21.764
Top-1	5300	21.531

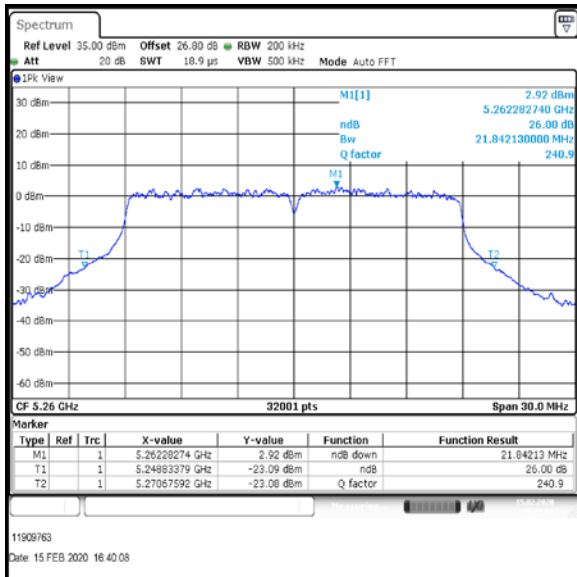

Bottom Channel

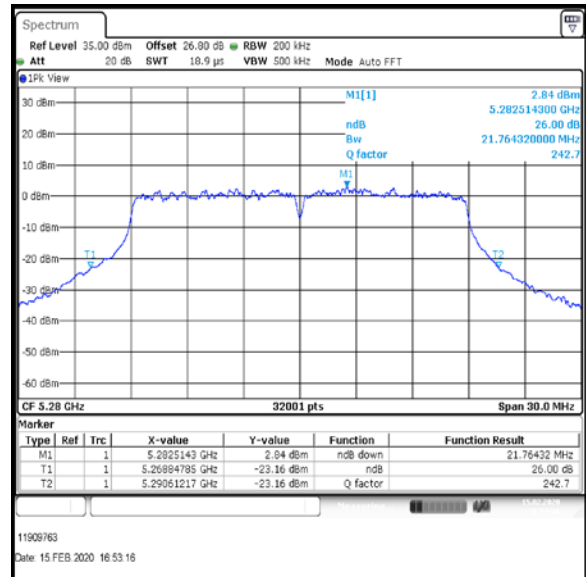

Middle Channel

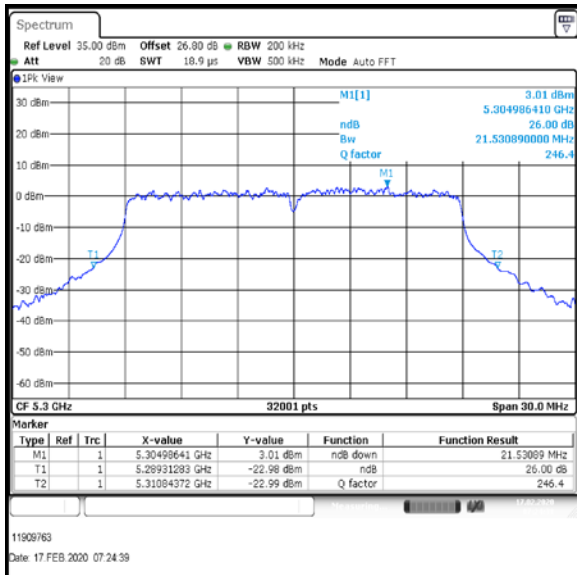

Top-1 Channel

Result: **Pass**

Transmitter 26 dB Emission Bandwidth (continued)

Results: 802.11n / HT20 / MCS4 / MIMO / Port 1+2 / Port 1 / PWL 12 / 9 dBi Antenna

Channel	Frequency (MHz)	26 dB Emission Bandwidth (MHz)
Top	5320	22.072

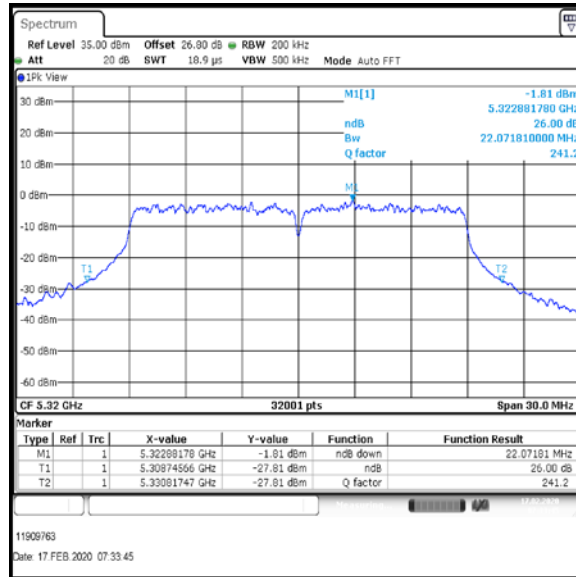

Top Channel

Result: **Pass**

Transmitter 26 dB Emission Bandwidth (continued)

Results: 802.11n / HT20 / MCS4 / MIMO / Port 1+2 / Port 2 / PWL 12 / 9 dBi Antenna

Channel	Frequency (MHz)	26 dB Emission Bandwidth (MHz)
Top	5320	21.588

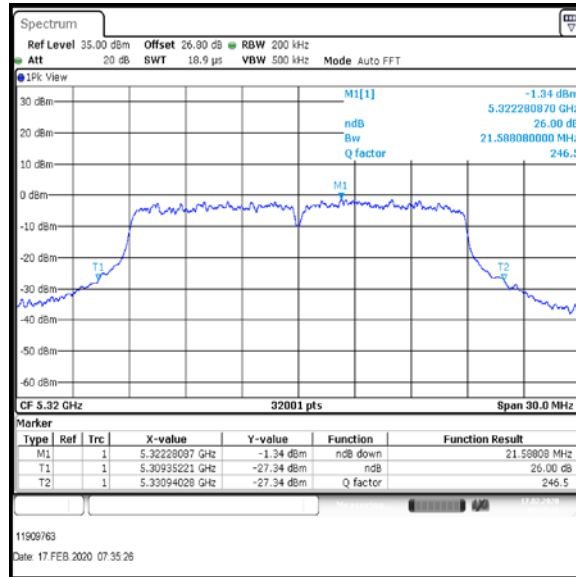

Top Channel

Result: **Pass**

Transmitter 26 dB Emission Bandwidth (continued)

Results: 802.11ac / HT20 / MCS0 / MIMO / Port 1+2 / Port 1 / PWL 18 / 9 dBi Antenna

Channel	Frequency (MHz)	26dB Emission Bandwidth (MHz)
Bottom	5260	19.72
Middle	5280	19.603
Top-1	5300	19.663

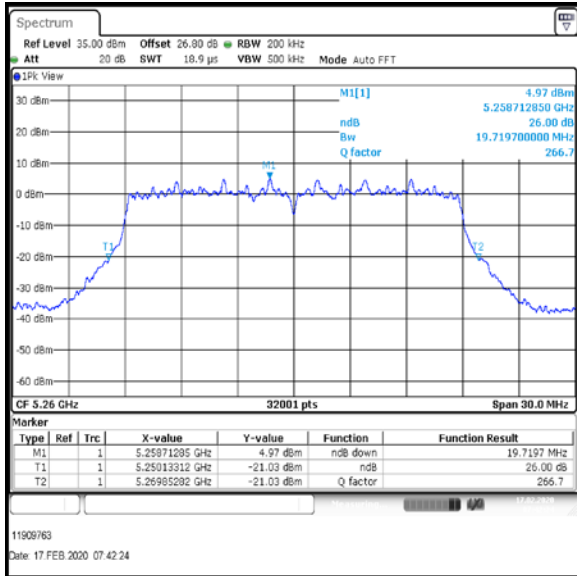

Bottom Channel

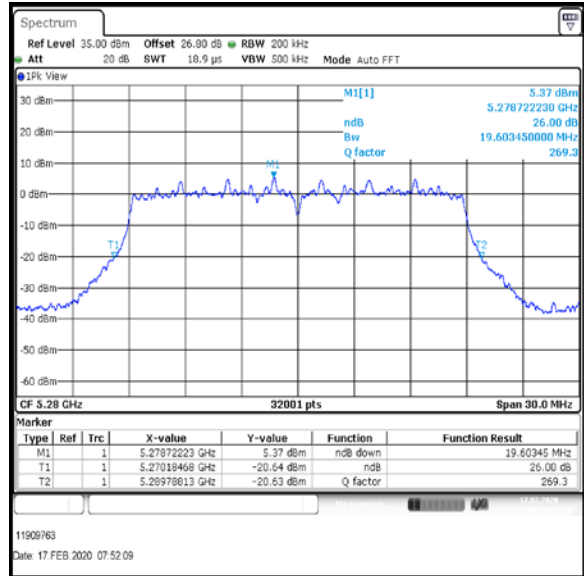

Middle Channel

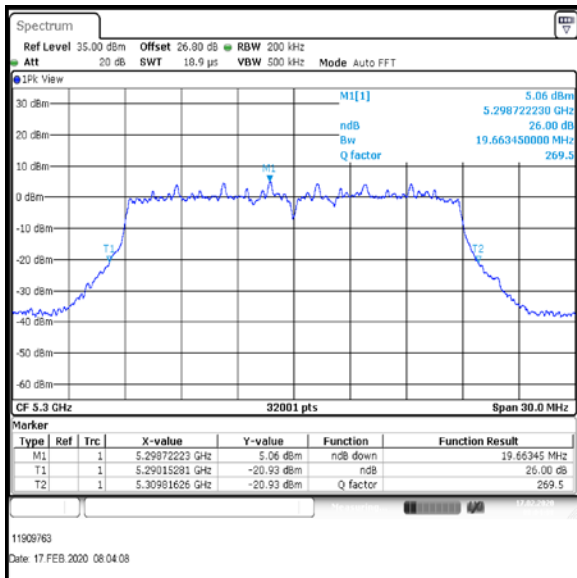

Top-1 Channel

Result: Pass

Transmitter 26 dB Emission Bandwidth (continued)

Results: 802.11ac / HT20 / MCS0 / MIMO / Port 1+2 / Port 2 / PWL 18 / 9 dBi Antenna

Channel	Frequency (MHz)	26dB Emission Bandwidth (MHz)
Bottom	5260	19.644
Middle	5280	19.943
Top-1	5300	19.901

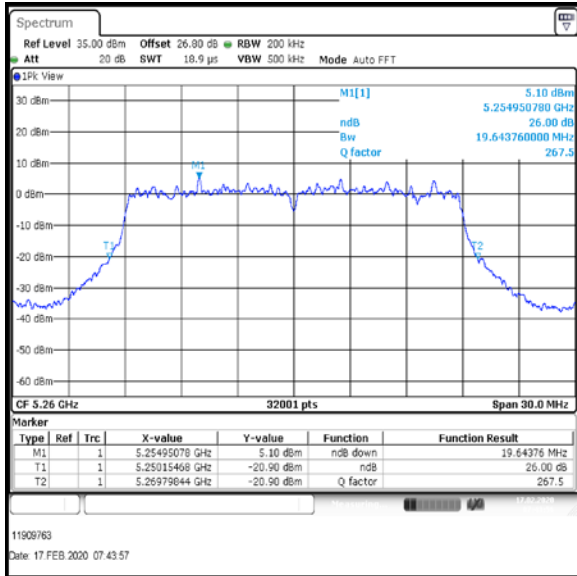

Bottom Channel

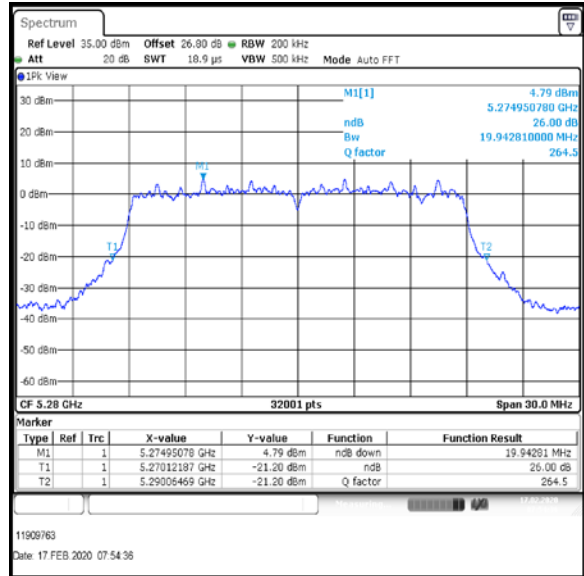

Middle Channel

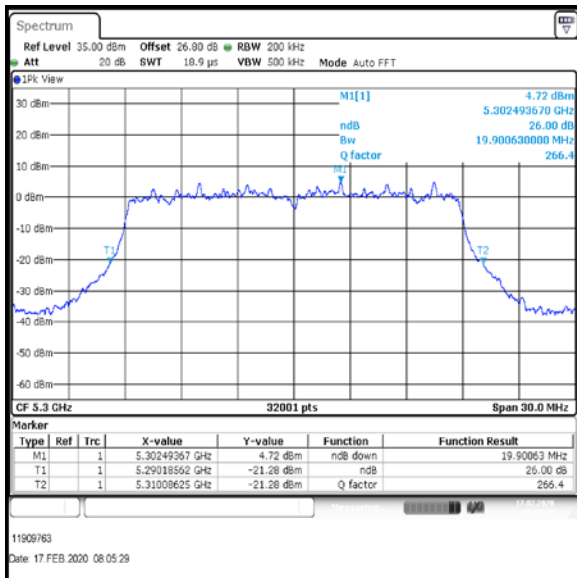

Top-1 Channel

Result: Pass

Transmitter 26 dB Emission Bandwidth (continued)

Results: 802.11ac / HT20 / MCS0 / MIMO / Port 1+2 / Port 1 / PWL 12 / 9 dBi Antenna

Channel	Frequency (MHz)	26dB Emission Bandwidth (MHz)
Top	5320	19.665

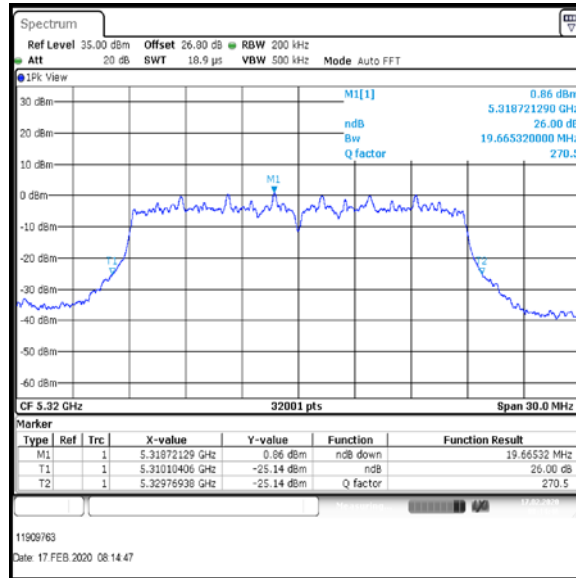

Top Channel

Result: **Pass**

Transmitter 26 dB Emission Bandwidth (continued)

Results: 802.11ac / HT20 / MCS0 / MIMO / Port 1+2 / Port 2 / PWL 12 / 9 dBi Antenna

Channel	Frequency (MHz)	26dB Emission Bandwidth (MHz)
Top	5320	19.813

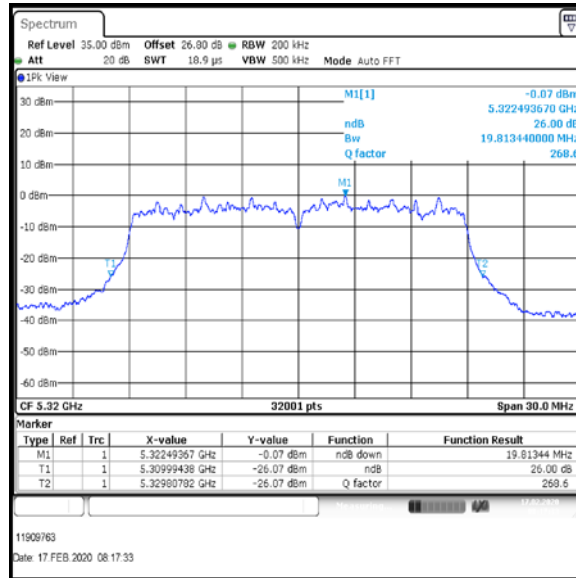

Top Channel

Result: **Pass**

Transmitter 26 dB Emission Bandwidth (continued)

Results: 802.11ac / HT20 / MCS4 / MIMO / Port 1+2 / Port 1 / PWL 18 / 9 dBi Antenna

Channel	Frequency (MHz)	26 dB Emission Bandwidth (MHz)
Bottom	5260	21.647
Middle	5280	21.328
Top-1	5300	21.263

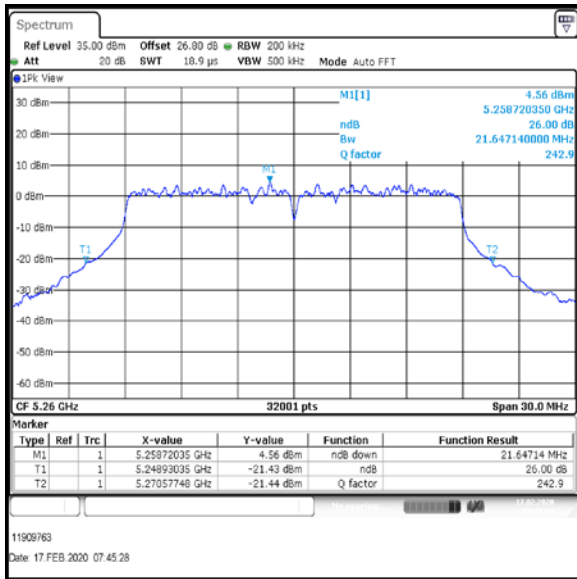

Bottom Channel

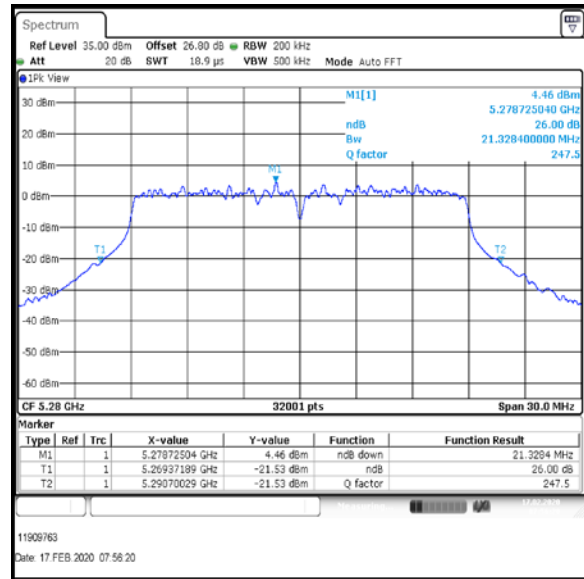

Middle Channel

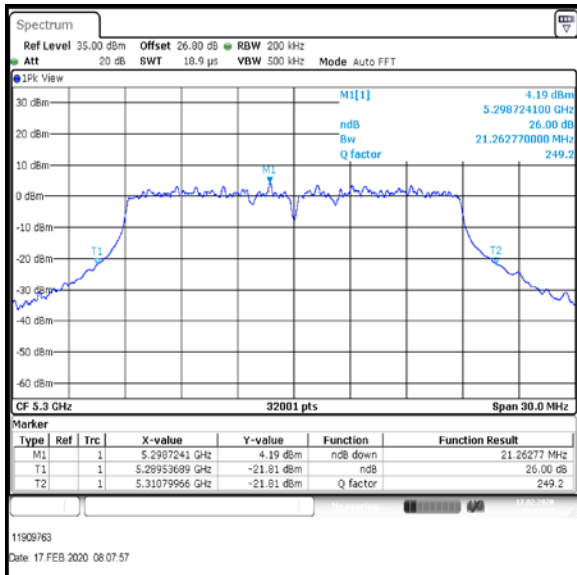

Top-1 Channel

Result: **Pass**

Transmitter 26 dB Emission Bandwidth (continued)

Results: 802.11ac / HT20 / MCS4 / MIMO / Port 1+2 / Port 2 / PWL 18 / 9 dBi Antenna

Channel	Frequency (MHz)	26 dB Emission Bandwidth (MHz)
Bottom	5260	21.241
Middle	5280	21.218
Top-1	5300	21.162

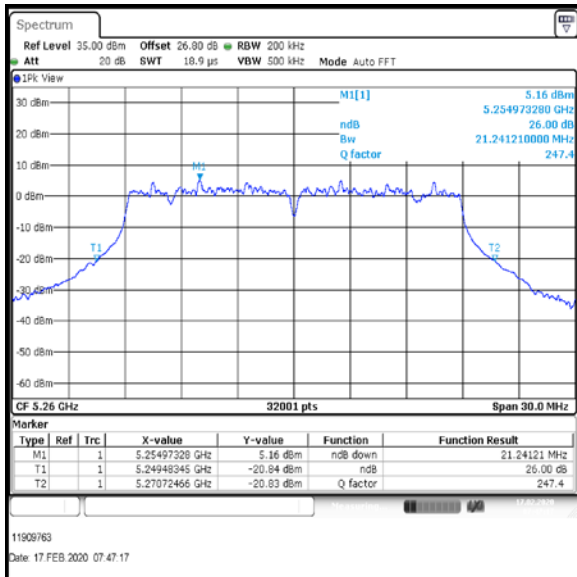

Bottom Channel

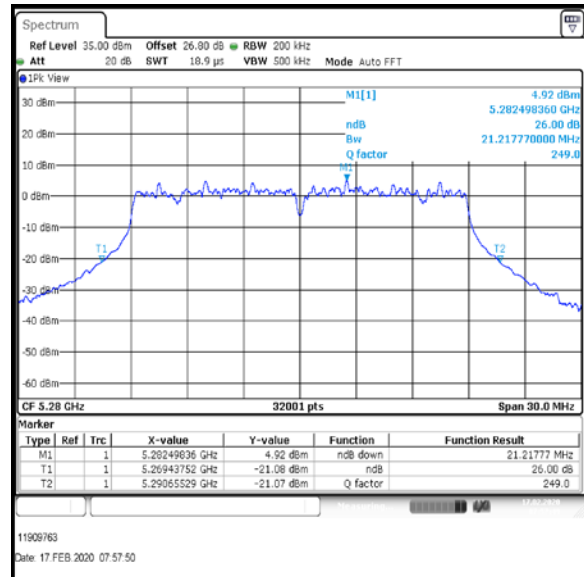

Middle Channel

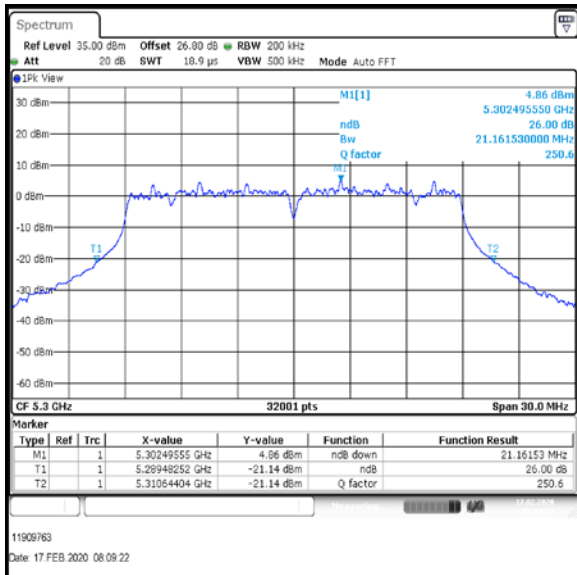

Top-1 Channel

Result: **Pass**

Transmitter 26 dB Emission Bandwidth (continued)

Results: 802.11ac / HT20 / MCS4 / MIMO / Port 1+2 / Port 1 / PWL 12 / 9 dBi Antenna

Channel	Frequency (MHz)	26 dB Emission Bandwidth (MHz)
Top	5320	21.504

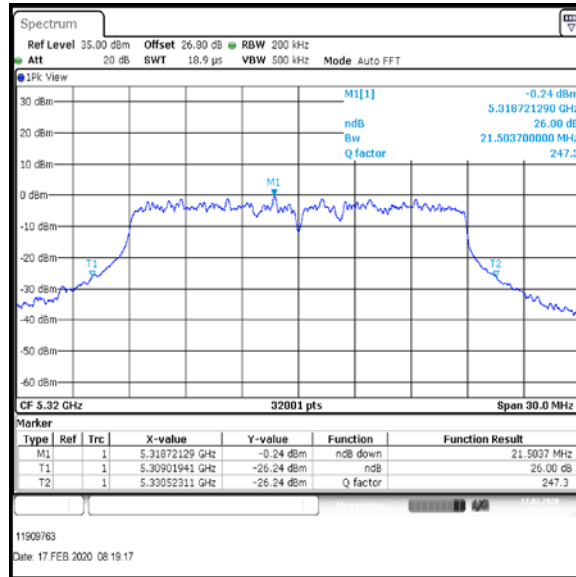

Top Channel

Result: **Pass**

Transmitter 26 dB Emission Bandwidth (continued)

Results: 802.11ac / HT20 / MCS4 / MIMO / Port 1+2 / Port 2 / PWL 12 / 9 dBi Antenna

Channel	Frequency (MHz)	26 dB Emission Bandwidth (MHz)
Top	5320	21.257

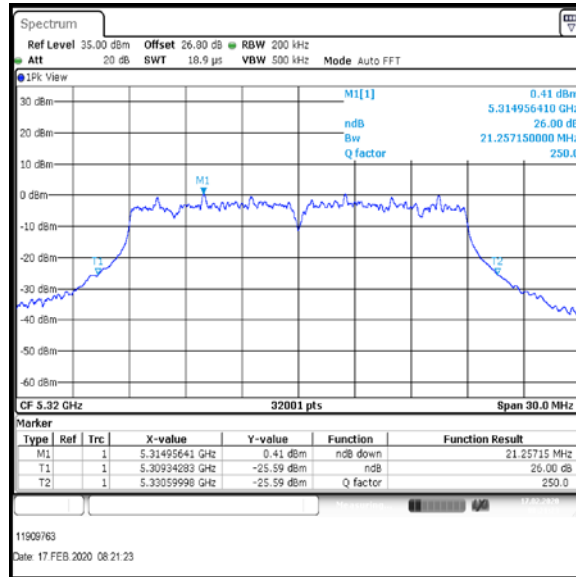

Top Channel

Result: **Pass**

Transmitter 26 dB Emission Bandwidth (continued)

Results: 802.11n / HT40 / MCS7 / MIMO / Port 1+2 / Port 1 / PWL 12 / 9 dBi Antenna

Channel	Frequency (MHz)	26 dB Emission Bandwidth (MHz)
Bottom	5270	44.588
Top	5310	43.364

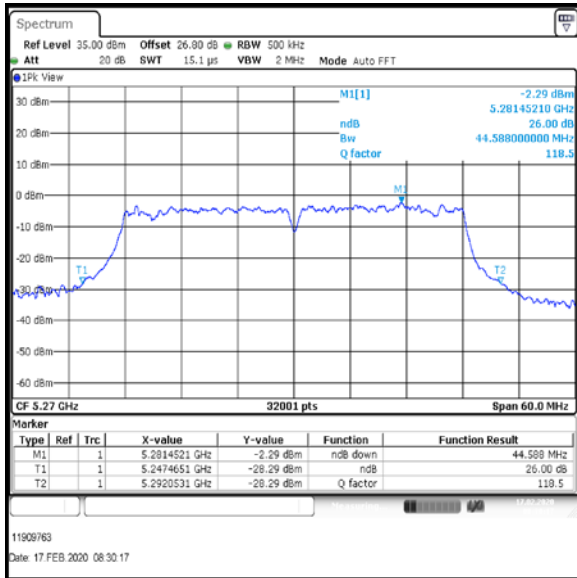

Bottom Channel

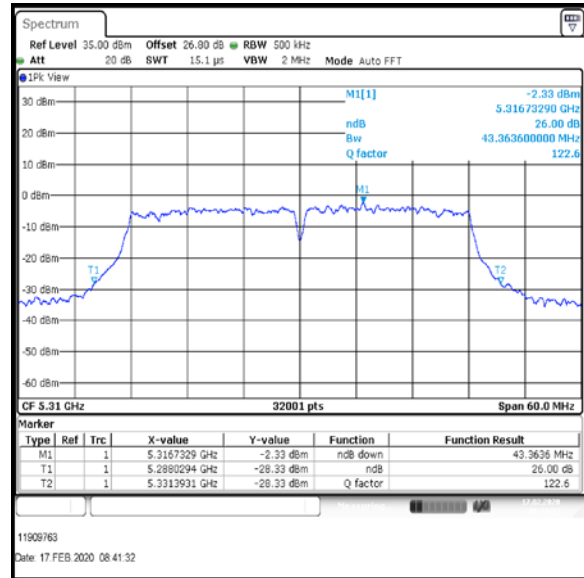

Top Channel

Result: **Pass**

Transmitter 26 dB Emission Bandwidth (continued)

Results: 802.11n / HT40 / MCS7 / MIMO / Port 1+2 / Port 2 / PWL 12 / 9 dBi Antenna

Channel	Frequency (MHz)	26 dB Emission Bandwidth (MHz)
Bottom	5270	43.542
Top	5310	43.217

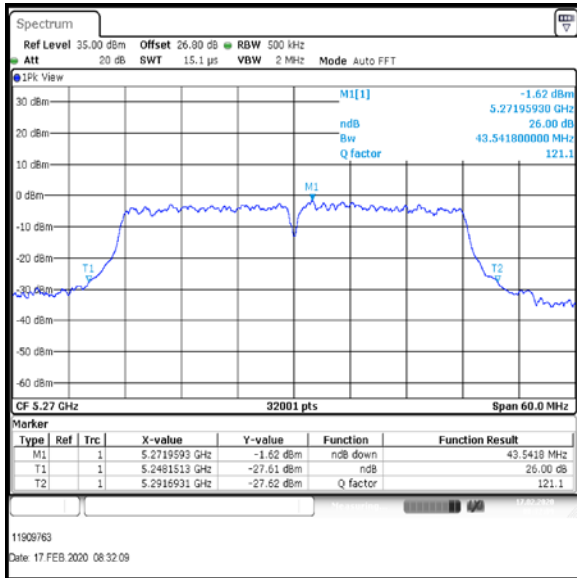

Bottom Channel

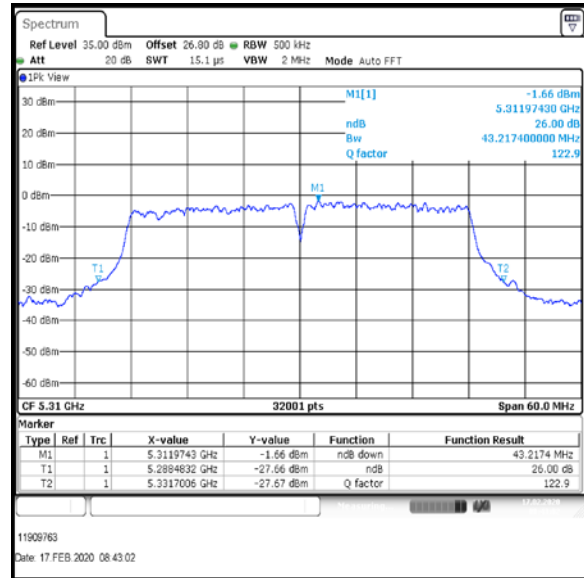

Top Channel

Result: **Pass**

Transmitter 26 dB Emission Bandwidth (continued)

Results: 802.11ac / HT40 / MCS7 / MIMO / Port 1+2 / Port 1 / PWL 12 / 9 dBi Antenna

Channel	Frequency (MHz)	26 dB Emission Bandwidth (MHz)
Bottom	5270	41.789
Top	5310	42.989

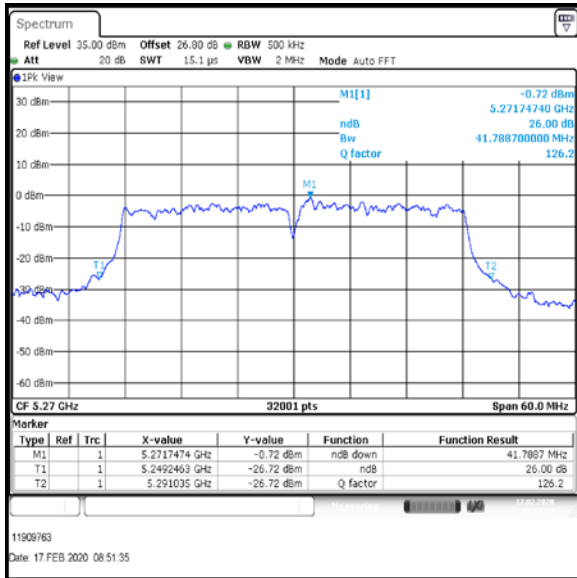

Bottom Channel

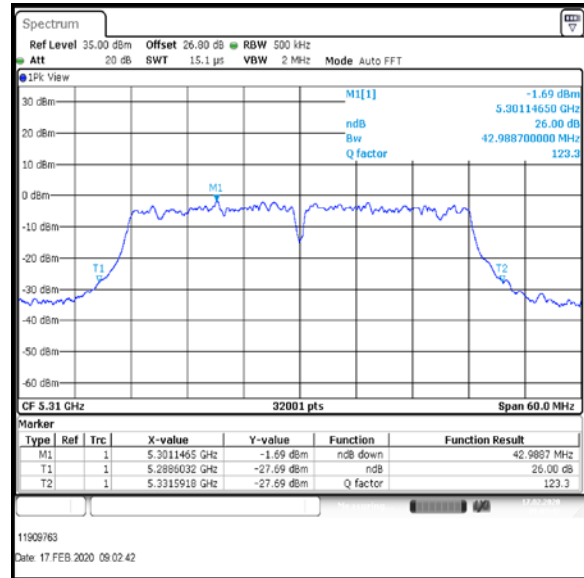

Top Channel

Result: **Pass**

Transmitter 26 dB Emission Bandwidth (continued)

Results: 802.11ac / HT40 / MCS7 / MIMO / Port 1+2 / Port 2 / PWL 12 / 9 dBi Antenna

Channel	Frequency (MHz)	26 dB Emission Bandwidth (MHz)
Bottom	5270	43.002
Top	5310	42.842

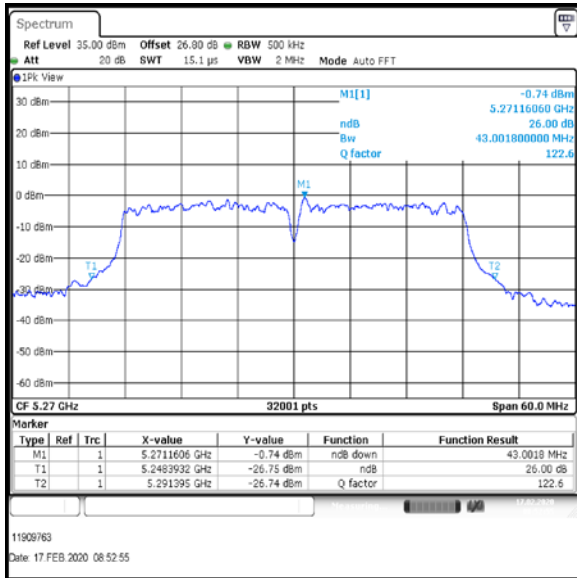

Bottom Channel

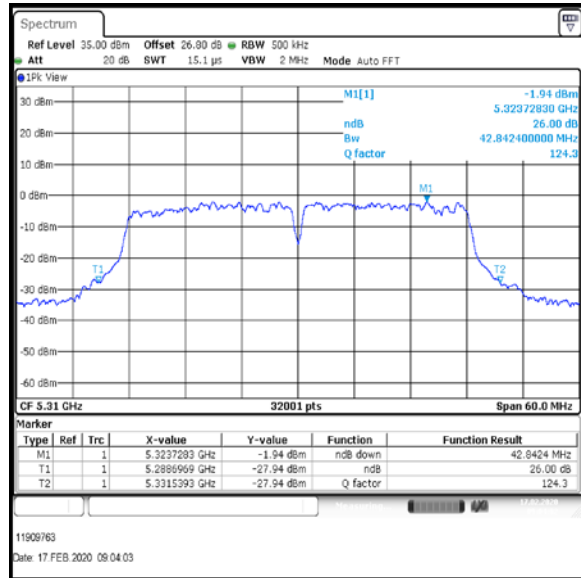

Top Channel

Result: **Pass**

Transmitter 26 dB Emission Bandwidth (continued)

Results: 802.11ac / HT80 / MCS5 / MIMO / Port 1+2 / Port 1 / PWL 12 / 9 dBi Antenna

Channel	Frequency (MHz)	26 dB Emission Bandwidth (MHz)
Single	5290	87.091

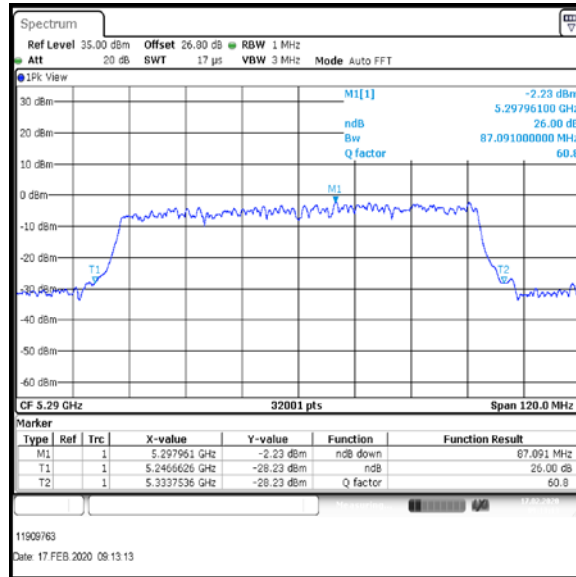

Single Channel

Result: **Pass**

Transmitter 26 dB Emission Bandwidth (continued)

Results: 802.11ac / HT80 / MCS5 / MIMO / Port 1+2 / Port 2 / PWL 12 / 9 dBi Antenna

Channel	Frequency (MHz)	26 dB Emission Bandwidth (MHz)
Single	5290	87.229

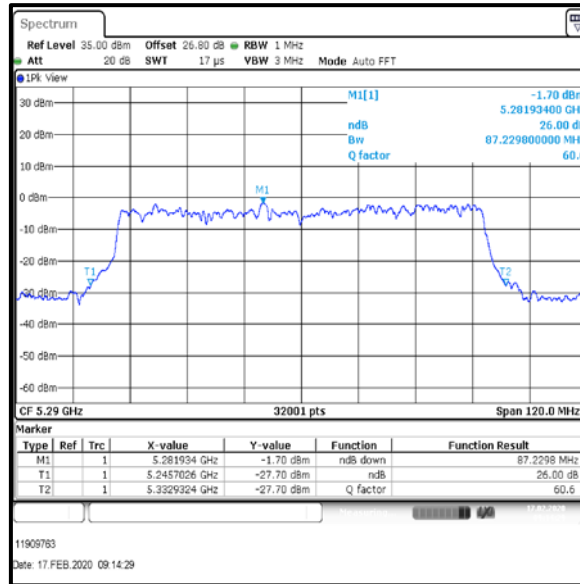

Single Channel

Result: **Pass**

Transmitter 26 dB Emission Bandwidth (continued)

Results: 802.11ac / HT80 / MCS9 / MIMO / Port 1+2 / Port 1 / PWL 12 / 9 dBi Antenna

Channel	Frequency (MHz)	26 dB Emission Bandwidth (MHz)
Single	5290	85.047

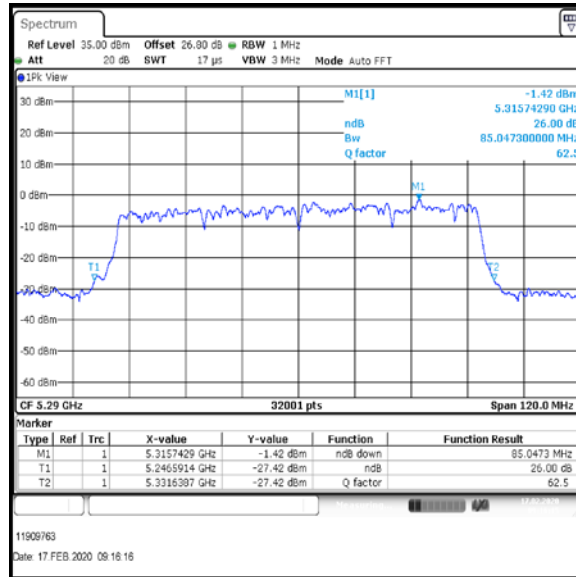

Single Channel

Result: **Pass**

Transmitter 26 dB Emission Bandwidth (continued)

Results: 802.11ac / HT80 / MCS9 / MIMO / Port 1+2 / Port 2 / PWL 12 / 9 dBi Antenna

Channel	Frequency (MHz)	26 dB Emission Bandwidth (MHz)
Single	5290	89.484

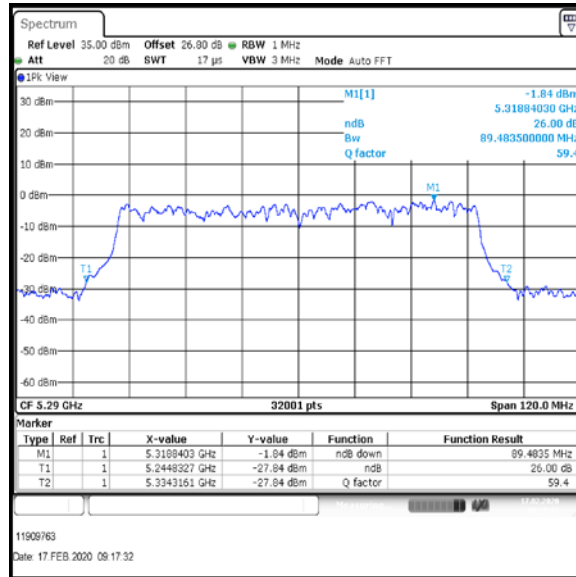

Single Channel

Result: **Pass**