



TEST REPORT

Test Report No. : UL-RPT-RP11909763-3516A V2.0

Customer : Siemens AG
Model No. : MPCIE-R1-ABGNAC-U4
FCC ID : LYHRAPACV1
Technology : WLAN
Test Standard(s) : FCC Parts 15.209(a) & 15.407(b)

Test Laboratory : UL VS LTD, Basingstoke, Hampshire, RG24 8AH, United Kingdom

1. This test report shall not be reproduced in full or partial, without the written approval of UL VS LTD.
2. The results in this report apply only to the sample(s) tested.
3. The sample tested is in compliance with the above standard(s).
4. The test results in this report are traceable to the national or international standards.
5. Version 2.0 supersedes all previous versions.

Date of Issue: 18 March 2020

Checked by:

Ben Mercer
Senior Test Engineer, Radio Laboratory

Company Signatory:

Sarah Williams
Senior Test Engineer, Radio Laboratory
UL VS LTD



UL VS LTD

Unit 1-3 Horizon, Kingsland Business Park, Wade Road, Basingstoke, Hampshire, RG24 8AH, UK
Telephone: +44 (0)1256 312000
Facsimile: +44 (0)1256 312001

Customer Information

Company Name:	Siemens AG
Address:	Östliche Rheinbrückenstr. 50, 76187 Karlsruhe, Germany

Report Revision History

Version Number	Issue Date	Revision Details	Revised By
1.0	17/02/2020	Initial Version	Ben Mercer
2.0	18/03/2020	Addresses TCB comments	Ben Mercer

Table of Contents

Customer Information.....	2
Report Revision History	2
1. Attestation of Test Results.....	4
1.1. Description of EUT	4
1.2. General Information	4
1.3. Summary of Test Results	5
1.4. Deviations from the Test Specification	5
2. Summary of Testing.....	6
2.1. Facilities and Accreditation	6
2.2. Methods and Procedures	6
2.3. Calibration and Uncertainty	7
2.4. Test and Measurement Equipment	8
3. Equipment Under Test (EUT)	11
3.1. Identification of Equipment Under Test (EUT)	11
3.2. Modifications Incorporated in the EUT	11
3.3. Additional Information Related to Testing	12
3.4. Description of Available Antennas	14
3.5. Tested Power Settings	15
3.6. Description of Test Setup	16
4. Antenna Port Test Results	22
4.1. Transmitter Duty Cycle	22
4.1.1. 5.25-5.35 GHz band	23
4.1.2. 5.47-5.725 GHz band	46
4.2. Transmitter Out of Band Conducted Emissions <1 GHz	72
4.3. Transmitter Out of Band Conducted Emissions >1 GHz	76
4.3.1. 5.25-5.35 GHz band	76
4.3.2. 5.47-5.725 GHz band	78
5. Radiated Test Results.....	84
5.1. Transmitter Out of Band Cabinet Radiated Emissions <1 GHz	84
5.2. Transmitter Out of Band Cabinet Radiated Emissions >1 GHz	87
5.2.1. 5.25-5.35 GHz band	87
5.2.2. 5.47-5.725 GHz band	91
5.3. Transmitter Band Edge Radiated Emissions	94
5.3.1. 5.25-5.35 GHz band	94
5.3.2. 5.47-5.725 GHz band	126

1. Attestation of Test Results





1.1. Description of EUT

The equipment under test was a 4x4 MIMO radio module supporting WLAN 2.4 GHz and WLAN 5 GHz technologies.

1.2. General Information

Specification Reference:	47CFR15.407
Specification Title:	Code of Federal Regulations Volume 47 (Telecommunications): Part 15 Subpart E (Unlicensed National Information Infrastructure Devices) – Section 15.407
Specification Reference:	47CFR15.209
Specification Title:	Code of Federal Regulations Volume 47 (Telecommunications): Part 15 Subpart C (Intentional Radiators) - Section 15.209
Site Registration:	621311
Location of Testing:	UL VS LTD, Unit 3 Horizon, Wade Road, Kingsland Business Park, Basingstoke, Hampshire, RG24 8AH, United Kingdom
Test Dates:	30 August 2019 to 16 October 2019

1.3. Summary of Test Results

FCC Reference (47CFR)	Measurement	Result
Part 15.35(c)	Transmitter Duty Cycle	Note 1
Part 15.407(b)/15.209(a)	Transmitter Out of Band Conducted Emissions	
Part 15.407(b)/15.209(a)	Transmitter Out of Band Cabinet Radiated Emissions	
Part 15.407(b)/15.209(a)	Transmitter Band Edge Radiated Emissions	
Key to Results		
 = Complied  = Did not comply		

Note(s):

- The measurement was performed to assist in the calculation of the average level of emissions as the EUT employs pulsed operation.

1.4. Deviations from the Test Specification

For the measurements contained within this test report, there were no deviations from, additions to, or exclusions from the test specifications identified above.

2. Summary of Testing

2.1. Facilities and Accreditation

The test site and measurement facilities used to collect data are located at Unit 3 Horizon, Wade Road, Kingsland Business Park, Basingstoke, Hampshire, RG24 8AH, United Kingdom. The following table identifies which facilities were utilised for radiated emission measurements documented in this report. Specific facilities are also identified in the test results sections.

Site 1	X
Site 2	-
Site 17	X

UL VS LTD is accredited by UKAS. The tests reported herein have been performed in accordance with its terms of accreditation.

2.2. Methods and Procedures

Reference:	ANSI C63.10-2013
Title:	American National Standard of Procedures for Compliance Testing of Unlicensed Wireless Devices
Reference:	KDB 789033 D02 General U-NII Test Procedures New Rules v02r01 December 14, 2017
Title:	Guidelines for Compliance Testing of Unlicensed National Information Infrastructure (U-NII) Devices (Part 15, Subpart E)
Reference:	KDB662911 D01 Multiple Transmitter Output v02r01 October 31, 2013
Title:	Emissions Testing of Transmitter with Multiple Outputs in the Same Band

2.3. Calibration and Uncertainty

Measuring Instrument Calibration

In accordance with UKAS requirements all the measurement equipment is on a calibration schedule. All equipment was within the calibration period on the date of testing.

Measurement Uncertainty

No measurement or test can ever be perfect and the imperfections give rise to error of measurement in the results. Consequently the result of a measurement is only an approximation to the value measured (the specific quantity subject to measurement) and is only complete when accompanied by a statement of the uncertainty of the approximation.

The expression of uncertainty of a measurement result allows realistic comparison of results with reference values and limits given in specifications and standards.

The uncertainty of the result may need to be taken into account when interpreting the measurement results.

The reported expanded uncertainties below are based on a standard uncertainty multiplied by an appropriate coverage factor such that a confidence level of approximately 95% is maintained. For the purposes of this document "approximately" is interpreted as meaning "effectively" or "for most practical purposes".

Measurement Type	Range	Confidence Level (%)	Calculated Uncertainty
Duty Cycle	5.15 GHz to 5.850 GHz	95%	±1.14 %
Radiated Spurious Emissions	30 MHz to 1 GHz	95%	±3.30 dB
Radiated Spurious Emissions	1 GHz to 40 GHz	95%	±2.94 dB
Conducted Spurious Emissions	9 kHz to 40 GHz	95%	±2.62 dB

The methods used to calculate the above uncertainties are in line with those recommended within the various measurement specifications. Where measurement specifications do not include guidelines for the evaluation of measurement uncertainty the published guidance of the appropriate accreditation body is followed.

2.4. Test and Measurement Equipment

Test Equipment Used for Transmitter Duty Cycle Conducted Tests

Asset No.	Instrument	Manufacturer	Type No.	Serial No.	Date Calibration Due	Cal. Interval (Months)
M2004	Thermohygrometer	Testo	608-H1	45046425	06 Jan 2020	12
M1883	Signal Analyser	Rhode & Schwarz	FSV30	103084	29 May 2020	12
A3004	RF Switch	Pickering Interfaccs	64-102-002	XZ363230	Calibrated before use	-
S0576	DC Power Supply	TTI	PL330QMD	066701	Calibrated before use	-
G0628	Signal Generator	Rhode & Schwarz	SMBV100A	261847	01 Sept 2020	36
M1818	Multimeter	Fluke	79 series III	71811580	13 Mar 2020	12
A3027	Attenuator	Broadwave Technologies Inc.	351-311-006	#1	Calibrated before use	-
A3028	Attenuator	Broadwave Technologies Inc.	351-311-006	#2	Calibrated before use	-
A3019	Attenuator	Broadwave Technologies Inc.	351-311-006	#3	Calibrated before use	-
A3030	Attenuator	Broadwave Technologies Inc.	351-311-006	#4	Calibrated before use	-

Test Measurement Software/Firmware Used

Name	Version	Release Date
UL VS LTD Replay	1	29 November 2018

Test and Measurement Equipment (continued)**Test Equipment Used for Transmitter Conducted Emissions**

Asset No.	Instrument	Manufacturer	Type No.	Serial No.	Date Calibration Due	Cal. Interval (Months)
M1932	Thermohygrometer	Testo	608-H1	45124919	06 Jan 2020	12
M1832	Signal Analyser	Agilent	N9010A	MY53470303	28 Mar 2020	24
M2036	Signal Analyser	Rohde & Schwarz	FSV30	101791	07 May2020	12
G0614	Signal Generator	Rohde & Schwarz	SMB100A	177687	08 May 2020	36
G0615	Vector Signal generator	Rohde & Schwarz	SMBV100A	260473	08 May 2020	36
A3084	2 GHz Low Pass Filter	AtlanTecRF	AFL-02000	18032100008	09 Apr 2020	12
A3014	6 GHz High Pass Filter	AtlanTecRF	AFH-06000	17042400007	20 Feb 2020	12
A3094	7 GHz High Pass Filter	AtlanTecRF	AFH-07000	18051600011	09 Apr 2020	12
A2481	Band Reject Filter	Wainwright Instruments GmbH	WRCJV16-554-5470-5725-5755-40	2	Calibrated Before Use	-
A2063	WG20 to SMA Adaptor	Flann Microwave	20094-SF-40	196553	Calibrated Before Use	-
A2058	WG20 to SMA Adaptor	Flann Microwave	20094-SF-40	196548	Calibrated Before Use	-
A174	WG22 to K-Type Adaptor	Flann Microwave	22094-KF20	211	Calibrated Before Use	-
A360	WG22 to K-Type Adaptor	Flann Microwave	22094-KF20	778	Calibrated Before Use	-
A2631	6dB Attenuator	Weinschel Associates	WA75-6-12	A300	Calibrated Before Use	-
A2632	10dB Attenuator	Weinschel Associates	WA75-10-12	A301	Calibrated Before Use	-
A2525	10dB Attenuator	AtlanTechRF	AN18W5-10	832827~3	Calibrated Before Use	-

Test and Measurement Equipment (continued)**Test Equipment Used for Transmitter Cabinet Radiated Emissions**

Asset No.	Instrument	Manufacturer	Type No.	Serial No.	Date Calibration Due	Cal. Interval (Months)
M2040	Thermohygrometer	Testo	608-H1	45124934	07 Jan 2021	12
K0017	3m RSE Chamber	Rainford EMC	N/A	N/A	01 Aug 2020	12
A490	Antenna	Chase	CBL6111A	1590	21 May 2020	12
M2044	Test Receiver	Rohde & Schwarz	ESU26	100122	01 Apr 2020	12
A3138	Antenna	Schwarzbeck	BBHA 9120 B	00702	04 Oct 2020	12
A2523	Attenuator	AtlanTecRF	AN18W5-10	832827#1	04 Mar 2020	12
A3167	Pre Amplifier	Com-Power	PAM-103	18020010	14 Aug 2020	12
M1995	Test Receiver	Rohde & Schwarz	ESU40	100428	08 May 2020	12
A3155	Pre Amplifier	Com-Power	PAM-118A	18040037	04 Oct 2020	12
A3139	Antenna	Schwarzbeck	HWRD750	00027	07 Oct 2020	12
A2892	Antenna	Schwarzbeck	BBHA 9170	9170-727	01 Aug 2020	12
A2893	Amplifier	Schwarzbeck	BBV 9721	9721-021	31 Jul 2020	12

Test Equipment Used for Transmitter Band Edge Radiated Emissions

Asset No.	Instrument	Manufacturer	Type No.	Serial No.	Date Calibration Due	Cal. Interval (Months)
M2040	Thermohygrometer	JM Handelpunkt	608-H1	45124934	07 Jan 2021	12
K0001	5m RSE Chamber	Rainford EMC	N/A	N/A	16 Oct 2020	12
A3179	Pre-Amplifier	Hewlett Packard	8449B	3008A00934	04 Apr 2020	12
M2044	Test Receiver	Rohde & Schwarz	ESU26	100122	01 Apr 2020	12
A3138	Antenna	Schwarzbeck	BBHA 9120B	00702	04 Oct 2020	12
A2523	Attenuator	AtlanTecRF	AN18W5-10	83282727#1	04 Mar 2020	12
K0017	3m RSE Chamber	Rainford	N/A	N/A	01 Aug 2020	12
M2003	Thermohygrometer	Testo	608-H1	45046641	06 Jan 2020	12
M1995	Test Receiver	Rohde & Schwarz	ESU40	100428	08 May 2020	12
A2916	Attenuator	AtlanTecRF	AN18W5-10	832827#1	20 Feb 2020	12
A2889	Antenna	Schwarzbeck	BBHA 9120 B	BBHA 9120 B 653	08 Aug 2020	12
A2863	Pre-Amplifier	Agilent	8449B	3008A02100	08 Aug 2020	12

3. Equipment Under Test (EUT)

3.1. Identification of Equipment Under Test (EUT)

Brand Name:	SIEMENS
Model Name or Number:	MPCIE-R1-ABGNAC-U4
Test Sample Serial Number:	2405066 (<i>Radiated sample #1</i>)
Hardware Version:	1
Software Version:	V02.00.00
FCC ID:	LYHRAPACV1

Brand Name:	SIEMENS
Model Name or Number:	MPCIE-R1-ABGNAC-U4
Test Sample Serial Number:	2405067 (<i>Conducted sample #1</i>)
Hardware Version:	1
Software Version:	V02.00.00
FCC ID:	LYHRAPACV1

Brand Name:	SIEMENS
Model Name or Number:	MPCIE-R1-ABGNAC-U4
Test Sample Serial Number:	2428534 (<i>Conducted / Radiated sample #2</i>)
Hardware Version:	1
Software Version:	V02.00.00
FCC ID:	LYHRAPACV1

3.2. Modifications Incorporated in the EUT

No modifications were applied to the EUT during testing.

3.3. Additional Information Related to Testing

Technology Tested:	WLAN (IEEE 802.11a,n,ac) / U-NII	
Type of Unit:	Transceiver	
Modulation:	BPSK, QPSK, 16QAM, 64QAM & 256QAM	
Data rates:	802.11a	6, 9, 12, 18, 24, 36, 48 & 54 Mbps (SISO, or MIMO with CDD)
	802.11n HT20	MCS0 to MCS7 (≤ 4 spatial stream), (SISO, or MIMO with CDD)
	802.11n HT40	MCS0 to MCS7 (≤ 4 spatial stream), (SISO, or MIMO with CDD)
	802.11ac VHT20	MCS0 to MCS8 (≤ 4 spatial streams) (SISO, or MIMO with CDD)
	802.11ac VHT40	MCS0 to MCS9 (≤ 4 spatial streams) (SISO, or MIMO with CDD)
	802.11ac VHT80	MCS0 to MCS9 (≤ 4 spatial streams) (SISO, or MIMO with CDD)
Power Supply Requirement(s):	Nominal	24.0 VDC (PCB) 3.3 VDC & 5.0 VDC (Module)

Additional Information Related to Testing (continued)

Channel Spacing:	20 MHz		
Transmit Frequency Band:	5250 MHz to 5350 MHz		
Transmit Channels Tested:	Channel ID	Channel Number	Channel Frequency (MHz)
	Bottom	52	5260
	Middle	56	5280
	Top	64	5320
Transmit Frequency Band:	5470 MHz to 5725 MHz		
Transmit Channels Tested:	Channel ID	Channel Number	Channel Frequency (MHz)
	Bottom	100	5500
	Middle	116	5580
	Top	140	5700
Channel Spacing:	40 MHz		
Transmit Frequency Band:	5250 MHz to 5350 MHz		
Transmit Channels Tested:	Channel ID	Channel Number	Channel Frequency (MHz)
	Bottom	54	5270
	Top	62	5310
Transmit Frequency Band:	5470 MHz to 5725 MHz		
Transmit Channels Tested:	Channel ID	Channel Number	Channel Frequency (MHz)
	Bottom	102	5510
	Middle	110	5550
	Top	134	5670
Channel Spacing:	80 MHz		
Transmit Frequency Band:	5250 MHz to 5350 MHz		
Transmit Channels Tested:	Channel ID	Channel Number	Channel Frequency (MHz)
	Single	58	5290
Transmit Frequency Band:	5470 MHz to 5725 MHz		
Transmit Channels Tested:	Channel ID	Channel Number	Channel Frequency (MHz)
	Bottom	106	5530
	Top	122	5610

3.4. Description of Available Antennas

The table below lists the external antenna that the manufacturer intends to use with the EUT. The antenna gain was stated by Siemens AG.

Radiation Pattern	Type	Model Number	Gain @ 2.4 GHz (dBi)	Gain @ 5 GHz (dBi)
Omni	Dipole	ANT795-6MN	6	8

For the measurements presented within this report, the following maximum gains were used:

Frequency Band (MHz)	G_{Antenna 1} (dBi)	G_{Antenna 2} (dBi)	G_{Antenna 3} (dBi)	G_{Antenna 4} (dBi)
5250 to 5350	8.0	8.0	8.0	8.0
5470 to 5725	8.0	8.0	8.0	8.0

3.5. Tested Power Settings**802.11a**

Channel	SISO	2Tx CDD	3Tx CDD	4Tx CDD
52	18	19	17	16
56	18	19	17	16
64	13	13	14	15
100	13	13	14	15
116	18	19	17	16
140	15	19	17	16

802.11n HT20

Channel	SISO	2Tx CDD	3Tx CDD	4Tx CDD
52	18	19	17	16
56	18	19	17	16
64	13	13	14	15
100	13	13	14	15
116	18	19	17	16
140	15	19	17	16

802.11n HT40

Channel	SISO	2Tx CDD	3Tx CDD	4Tx CDD
54	13	13	14	15
62	13	13	14	15
102	13	13	14	15
110	13	13	14	15
134	13	13	14	15

802.11ac VHT80

Channel	SISO	2Tx CDD	3Tx CDD	4Tx CDD
58	13	13	14	15
106	13	13	14	15
122	13	13	14	15

3.6. Description of Test Setup

Support Equipment

The following support equipment was used to exercise the EUT during testing:

Description:	Laptop PC
Brand Name:	Lenovo
Model Name or Number:	L480
Serial Number:	PF1EJ3BY

Description:	DC Power Supply Cable. Length 2.0 metres. Quantity 2
Brand Name:	Not marked or stated
Model Name or Number:	Not marked or stated
Serial Number:	Not marked or stated

Description:	M12 to RJ45 Ethernet Cable. Length 2.0 metres. Quantity 2
Brand Name:	Siemens
Model Name or Number:	6XV1870-2E
Serial Number:	Not marked or stated

Description:	N-Type Antenna Cable. Length 10 metres. Quantity 4
Brand Name:	Siemens
Model Name or Number:	6XV1875-5AN10
Serial Number:	Not marked or stated

Description:	UMCC to N-Type Cable. Length 0.25 meters. Quantity 4
Brand Name:	Siemens
Model Name or Number:	Not marked or stated
Serial Number:	Not marked or stated

Description:	5 Port Ethernet Switch
Brand Name:	Netgear
Model Name or Number:	GS605
Serial Number:	1YG194390218E

Description:	PCB Board
Brand Name:	Siemens
Model Name or Number:	GTW 18 94V-0
Serial Number:	Not marked or stated

Operating Modes

The EUT was tested in the following operating mode(s):

- Continuously transmitting with a modulated carrier at maximum power on the bottom, middle and top channels as required using the supported data rates/modulation types.

Configuration and Peripherals

The EUT was tested in the following configuration(s):

- Controlled in test mode using CLI commands supplied by the customer. The commands were used to enable continuous transmission and to select the test channels and data rates as required. The EUT was connected to a laptop PC via an Ethernet cable.
- Transmitter spurious emissions were performed with the EUT transmitting with a data rate of 802.11n / 20 MHz / MIMO / 2Tx CDD / MCS0.
- Transmitter radiated tests were performed with a laptop PC and Ethernet router connected to the EUT. The laptop PC and router were placed outside the chamber. There were no other ports to terminate.
- Transmitter radiated band edge emissions were performed with the EUT & Antennas in the orientation resulting in the worst case emissions.
- Transmitter cabinet radiated emissions were performed with all antenna ports terminated into 50Ω loads.
- The EUT was powered from a 24 VDC power supply via a 120 VAC 60 Hz single phase mains supply.
- RF cables and attenuators connecting the test equipment to the EUT were calibrated before use and the calibration data incorporated into the conducted measurement results.
- All supported modes and channel widths were initially investigated on one channel. The modes that produced the highest power and widest bandwidth for all bands were:
 - Highest power
 - 802.11a SISO – 64-QAM / 54 Mbps / Port 1
 - 802.11n HT20 SISO – 64-QAM / MCS6 / Port 1
 - 802.11n HT40 SISO – 16-QAM / MCS4 / Port 1
 - 802.11ac VHT80 SISO – QPSK / MCS1x1 / Port 1
 - 802.11a MIMO – 64-QAM / 54 Mbps / 2Tx CDD / Ports 1 & 2
 - 802.11n HT20 MIMO – 16-QAM / MCS4 / 2Tx CDD / Ports 1 & 2
 - 802.11n HT40 MIMO – 64-QAM / MCS7 / 2Tx CDD / Ports 1 & 2
 - 802.11ac VHT80 MIMO – 64-QAM / MCS5x1 / 2Tx CDD / Ports 1 & 2
 - 802.11a MIMO – BPSK / 9 Mbps / 3Tx CDD / Ports 1, 2 & 3
 - 802.11n HT20 MIMO – 64-QAM / MCS7 / 3Tx CDD / Ports 1, 2 & 3
 - 802.11n HT40 MIMO – 64-QAM / MCS5 / 3Tx CDD / Ports 1, 2 & 3
 - 802.11ac VHT80 MIMO – QPSK / MCS1x1 / 3Tx CDD / Ports 1, 2 & 3
 - 802.11a MIMO – QPSK / 12 Mbps / 4Tx CDD / Ports 1, 2, 3 & 4
 - 802.11n HT20 MIMO – QPSK / MCS1 / 4Tx CDD / Ports 1, 2, 3 & 4
 - 802.11n HT40 MIMO – 16-QAM / MCS3 / 4Tx CDD / Ports 1, 2, 3 & 4
 - 802.11ac VHT80 MIMO – 64-QAM / MCS6x1 / 4Tx CDD / Ports 1, 2, 3 & 4

Configuration and Peripherals (continued)

- o Widest bandwidth
 - o 802.11a SISO – 64-QAM / 48 Mbps / Port 1
 - o 802.11n HT20 SISO – QPSK / MCS2 / Port 1
 - o 802.11n HT40 SISO – 16-QAM / MCS3 / Port 1
 - o 802.11ac VHT80 SISO – 256-QAM / MCS8x1 / Port 1
 - o 802.11a MIMO – 64-QAM / 48 Mbps / 2Tx CDD / Ports 1 & 2
 - o 802.11n HT20 MIMO – BPSK / MCS0 / 2Tx CDD / Ports 1 & 2
 - o 802.11n HT40 MIMO – 64-QAM / MCS7 / 2Tx CDD / Ports 1 & 2
 - o 802.11ac VHT80 MIMO – 256-QAM / MCS9x1 / 2Tx CDD / Ports 1 & 2
 - o 802.11a MIMO – QPSK / 12 Mbps / 3Tx CDD / Ports 1, 2 & 3
 - o 802.11n HT20 MIMO – 16-QAM / MCS3 / 3Tx CDD / Ports 1, 2 & 3
 - o 802.11n HT40 MIMO – 16-QAM / MCS3 / 3Tx CDD / Ports 1, 2 & 3
 - o 802.11ac VHT80 MIMO – QPSK / MCS2x1 / 3Tx CDD / Ports 1, 2 & 3
 - o 802.11a MIMO – QPSK / 12 Mbps / 4Tx CDD / Ports 1, 2, 3 & 4
 - o 802.11n HT20 MIMO – QPSK / MCS2 / 4Tx CDD / Ports 1, 2, 3 & 4
 - o 802.11n HT40 MIMO – 16-QAM / MCS7 / 4Tx CDD / Ports 1, 2, 3 & 4
 - o 802.11ac VHT80 MIMO – 16-QAM / MCS3x1 / 4Tx CDD / Ports 1, 2, 3 & 4

Worst case analysis data for all modes is archived on the Company server and available for inspection if required.

Test Setup Diagrams

Conducted Tests:

Test Setup for Transmitter Duty Cycle Conducted Tests

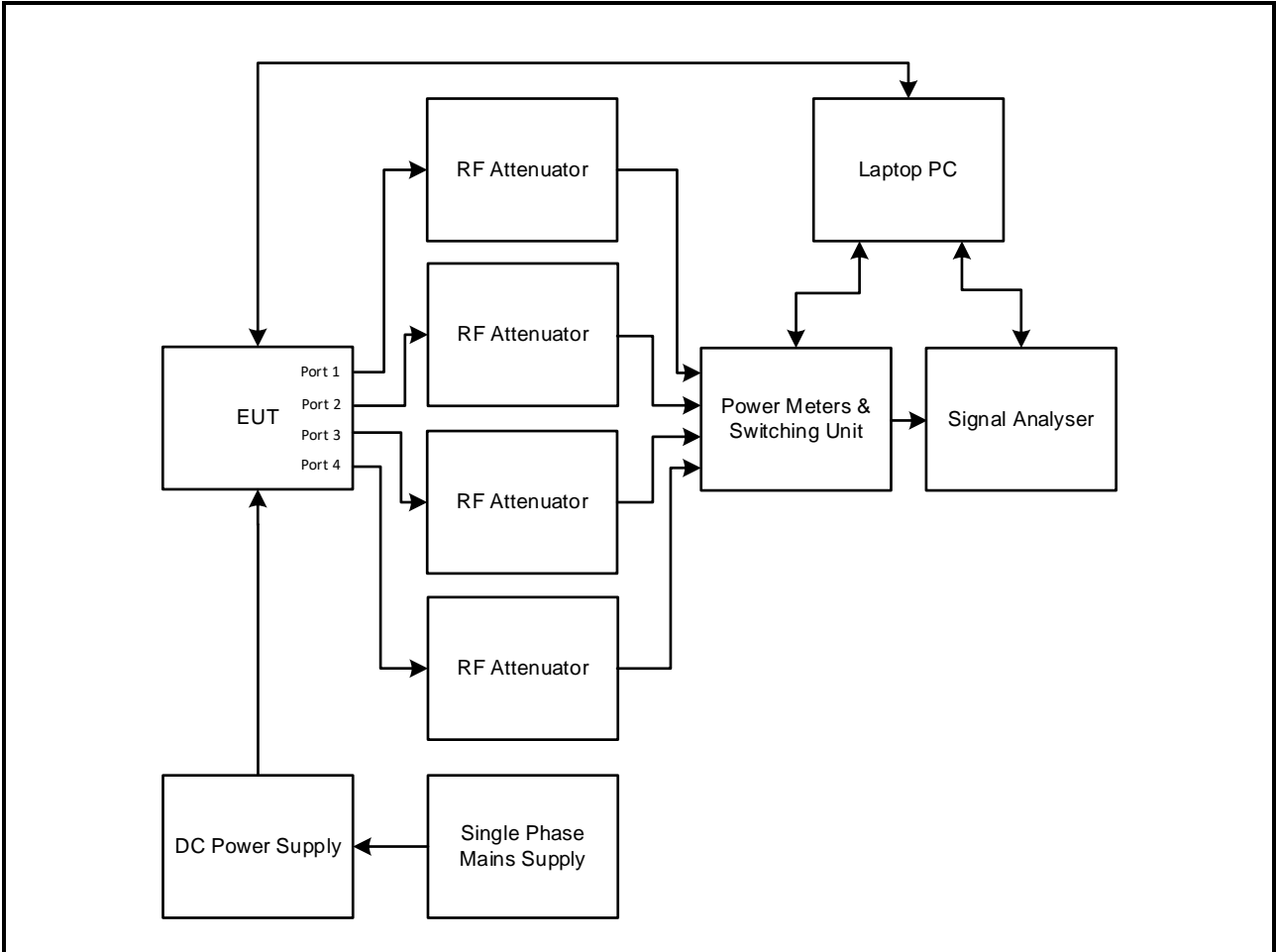

Test Setup for Transmitter Conducted Out of Band Tests

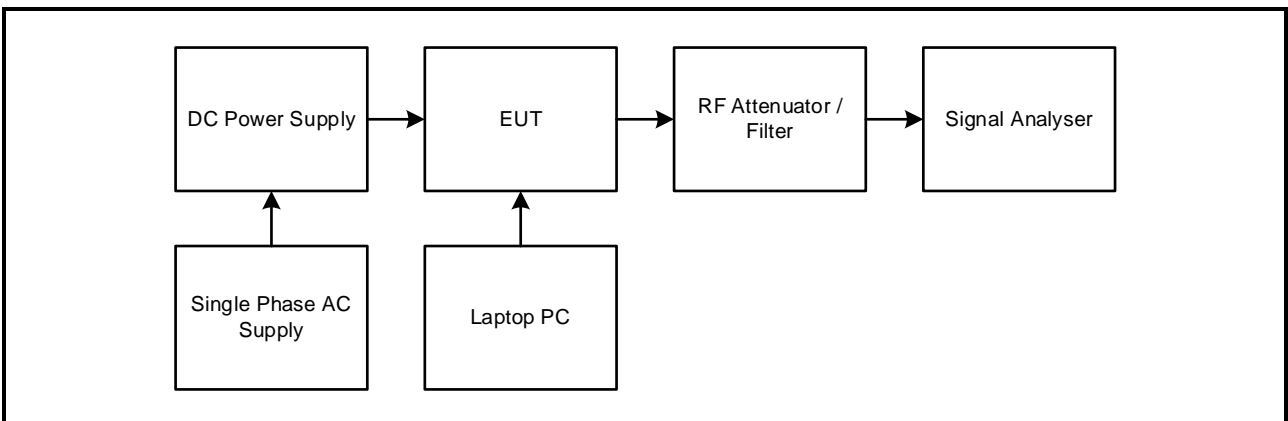

Radiated Tests:

Test Setup for Transmitter Cabinet Radiated Emissions

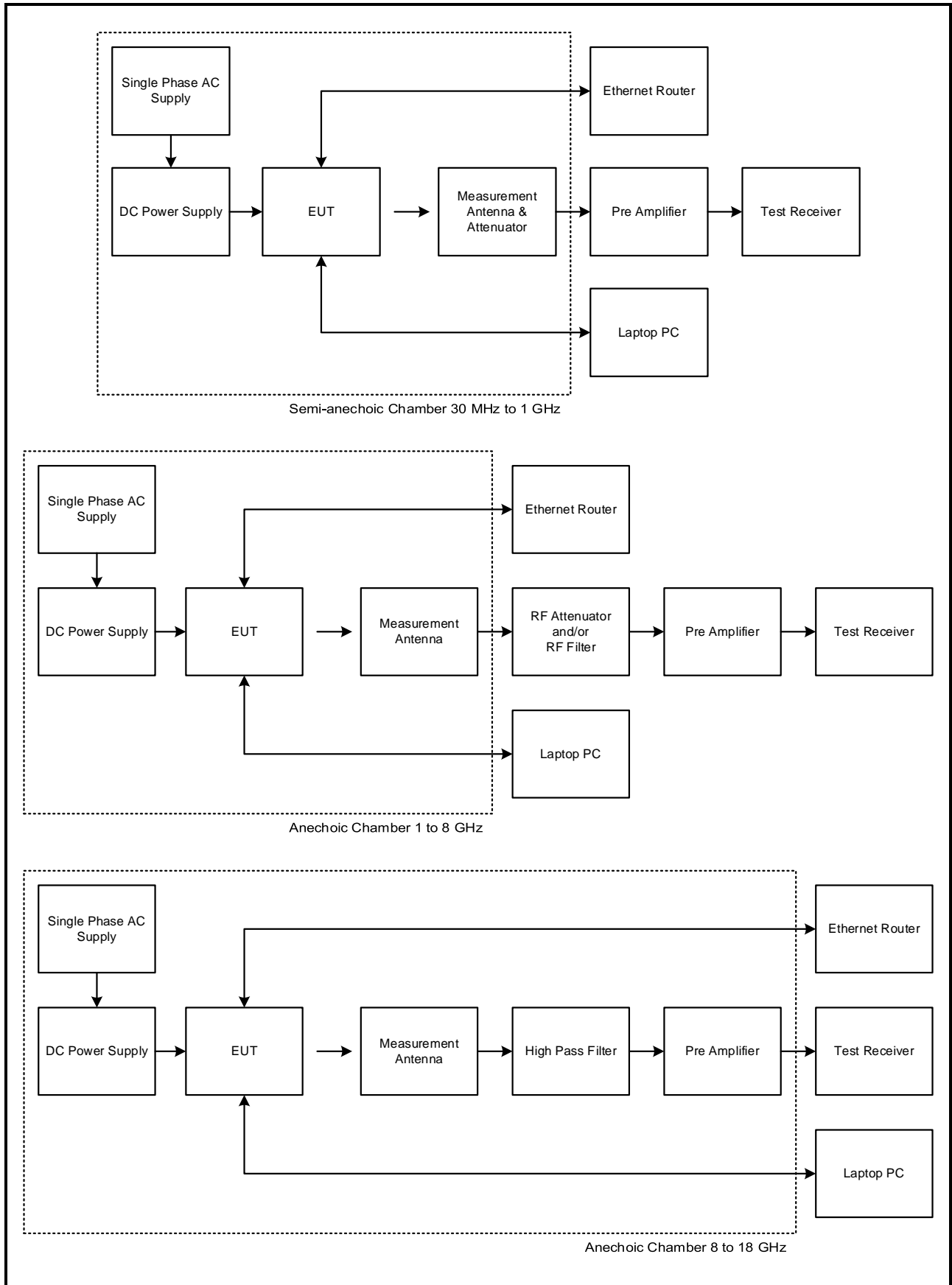

Test Setup for Transmitter Cabinet Radiated Emissions (continued)

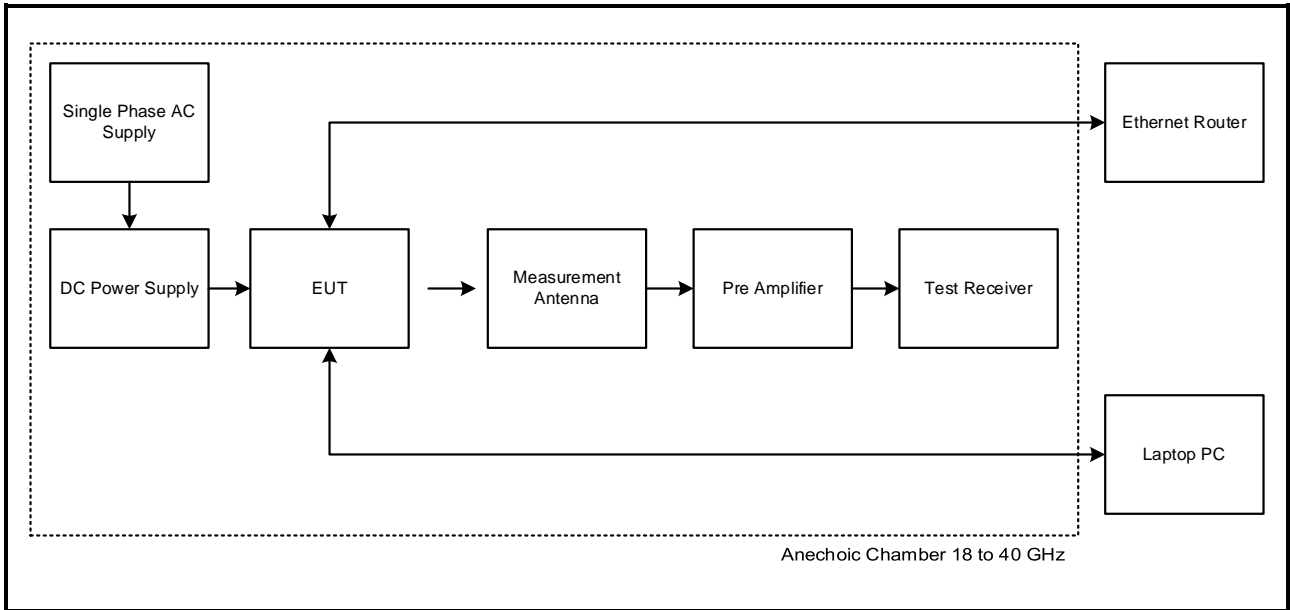

Test Setup for Transmitter Radiated Band Edge Emissions

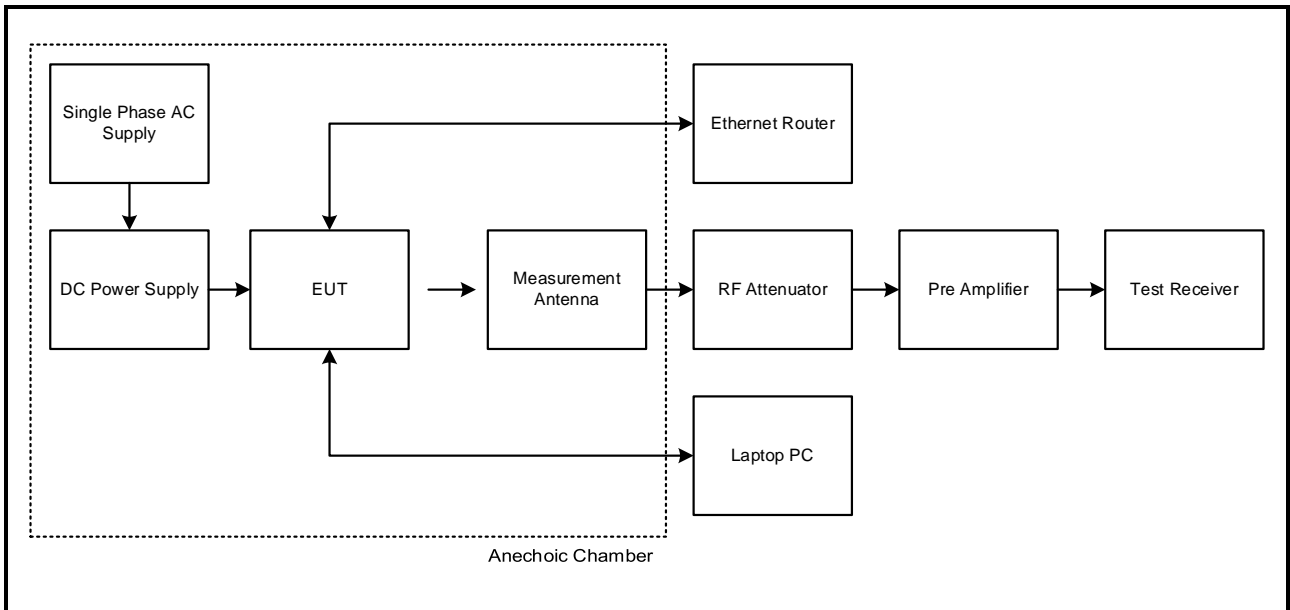

4. Antenna Port Test Results

4.1. Transmitter Duty Cycle

Test Summary:

Test Engineer:	Max Passell	Test Dates:	30 August 2019 to 16 October 2019
Test Sample Serial Number:	2405067		

FCC Reference:	Part 15.35(c)
Test Method Used:	KDB 789033 D02 Section II.B.2.b)

Environmental Conditions:

Temperatures (°C):	21 to 24
Relative Humidity (%):	35 to 44

Note(s):

- In order to assist with the determination of the average level of fundamental and spurious emissions field strength, measurements were made of duty cycle to determine the transmission duration and the silent period time of the transmitter. The transmitter duty cycle was measured using a spectrum analyser in the time domain and calculated by using the following calculation:

$$10 \log 1 / (\text{On Time} / [\text{Period or } 100\text{ms whichever is the lesser}]).$$
- Measurements were performed on all EUT ports and found to be identical. Therefore only results for port 1 are presented in the section of the test report.
- The signal analyser was connected to the RF port on the EUT using an RF switch, suitable attenuation and RF cables. An RF level offset was entered on the signal analyser to compensate for the loss of the switch, attenuators and RF cables.

Transmitter Duty Cycle (continued)

4.1.1. 5.25-5.35 GHz band

Results: 802.11a / 20 MHz / SISO / 64-QAM / 48 Mbps / Port 1

Channel	Frequency (MHz)	Pulse Duration (ms)	Period (ms)	Duty Cycle (dB)
Bottom	5260	0.1994	0.2782	1.4
Middle	5280	0.1994	0.2991	1.8
Top	5320	0.1995	0.2881	1.6

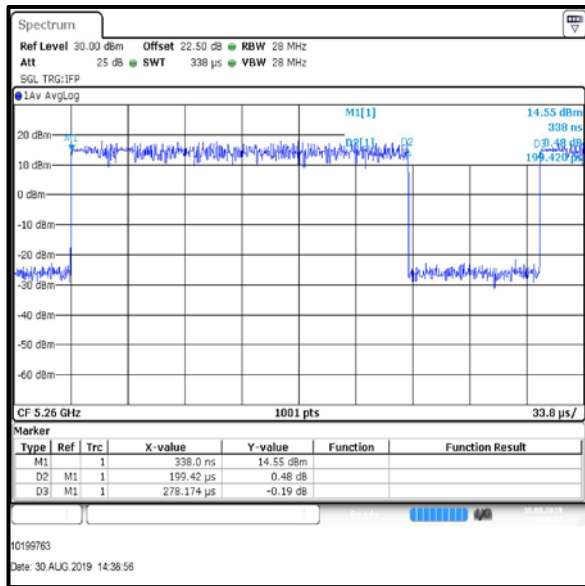

Bottom Channel

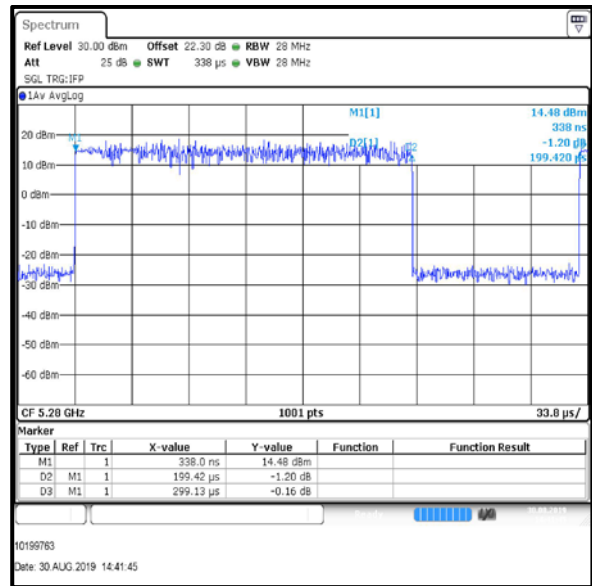

Middle Channel

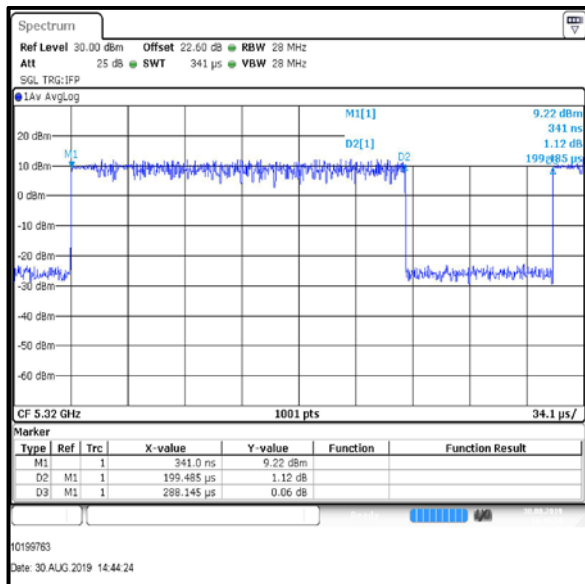

Top Channel

Transmitter Duty Cycle (continued)

Results: 802.11a / 20 MHz / SISO / 64-QAM / 54 Mbps / Port 1

Channel	Frequency (MHz)	Pulse Duration (ms)	Period (ms)	Duty Cycle (dB)
Bottom	5260	0.1993	0.2851	1.6
Middle	5280	0.1995	0.2810	1.5
Top	5320	0.1994	0.2812	1.5

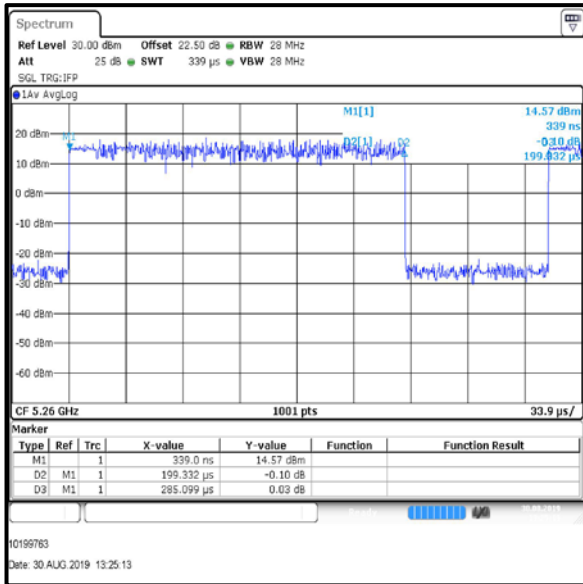

Bottom Channel

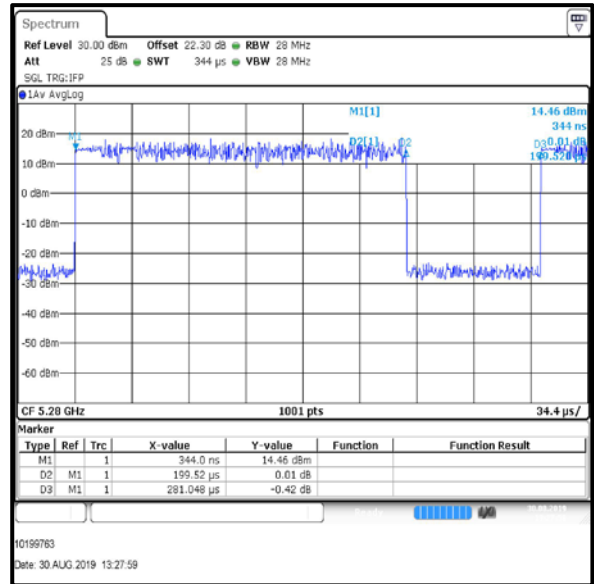

Middle Channel

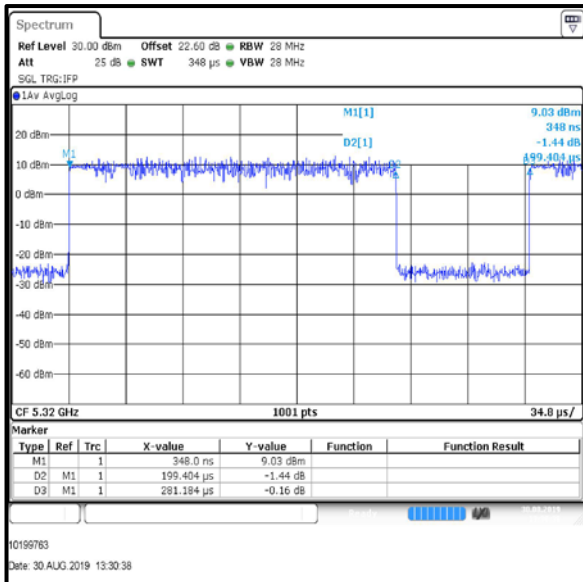

Top Channel

Transmitter Duty Cycle (continued)

Results: 802.11n / 20 MHz / SISO / QPSK / MCS2 / Port 1

Channel	Frequency (MHz)	Pulse Duration (ms)	Period (ms)	Duty Cycle (dB)
Bottom	5260	0.1994	0.2993	1.8
Middle	5280	0.1994	0.2991	1.8
Top	5320	0.1994	0.2991	1.8

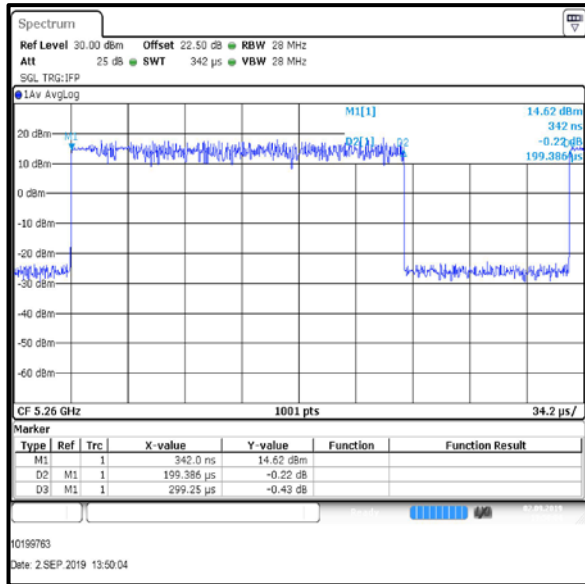

Bottom Channel

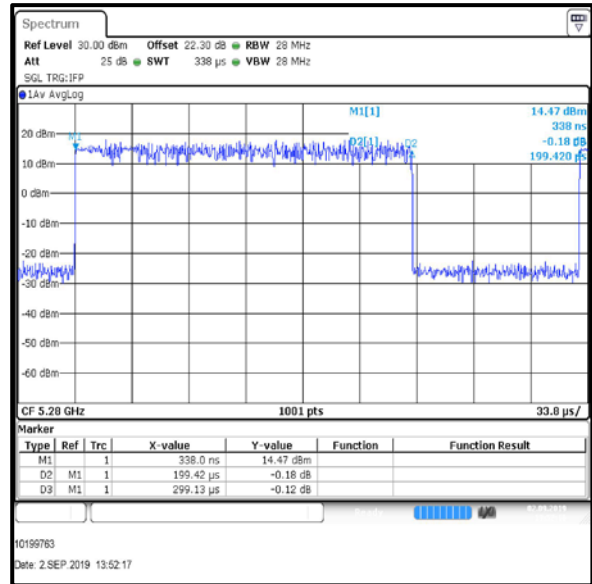

Middle Channel

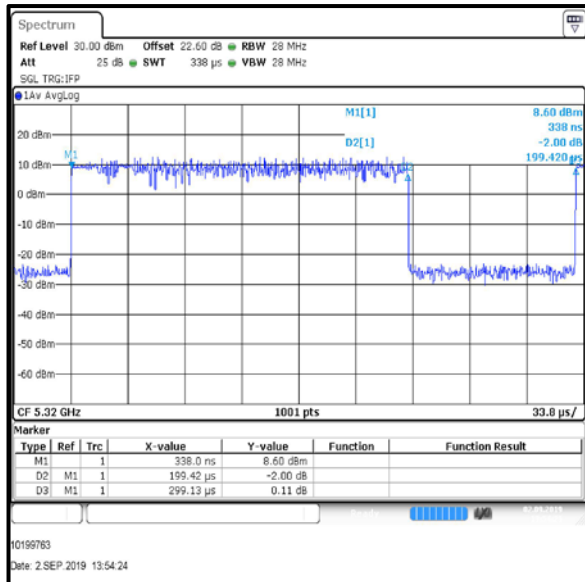

Top Channel

Transmitter Duty Cycle (continued)

Results: 802.11n / 20 MHz / SISO / 64-QAM / MCS6 / Port 1

Channel	Frequency (MHz)	Pulse Duration (ms)	Period (ms)	Duty Cycle (dB)
Bottom	5260	0.1994	0.2792	1.5
Middle	5280	0.1994	0.2822	1.5
Top	5320	0.1994	0.2991	1.8

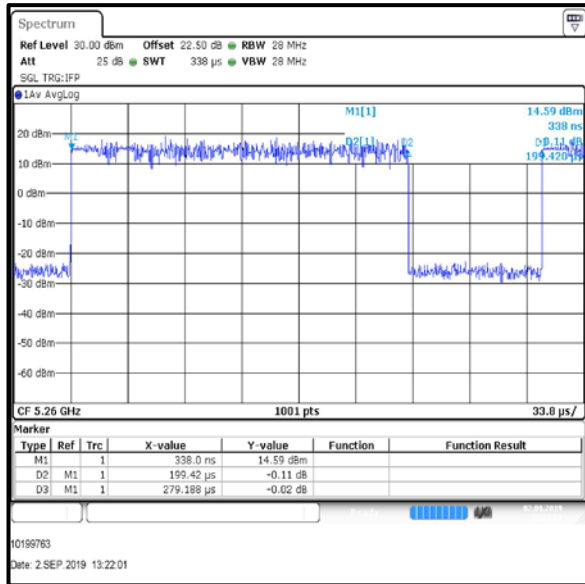

Bottom Channel

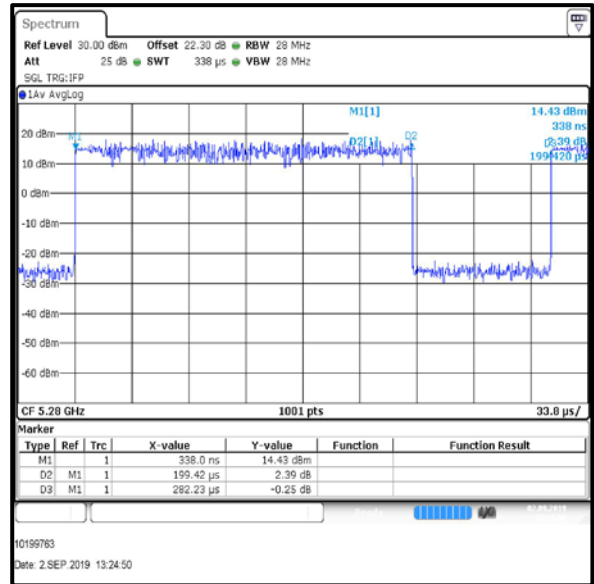

Middle Channel

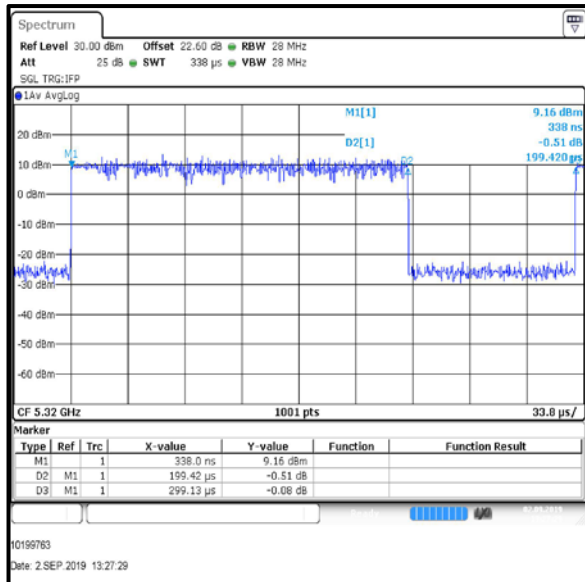

Top Channel

Transmitter Duty Cycle (continued)

Results: 802.11n / 40 MHz / SISO / 16-QAM / MCS3 / Port 1

Channel	Frequency (MHz)	Pulse Duration (ms)	Period (ms)	Duty Cycle (dB)
Bottom	5270	0.1195	0.1902	2.0
Top	5310	0.1195	0.2083	2.4

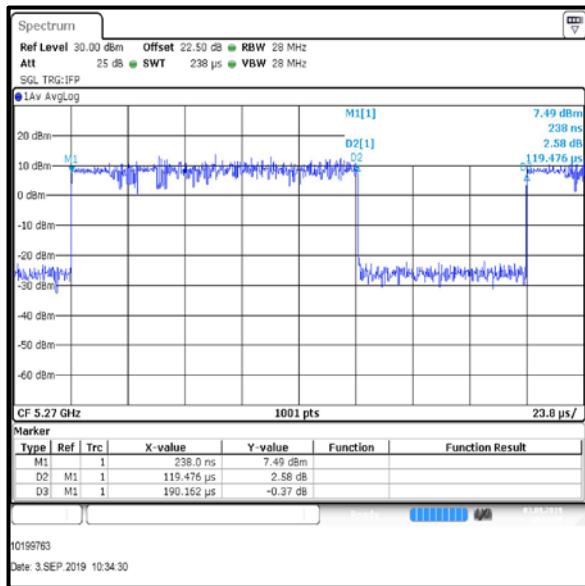

Bottom Channel

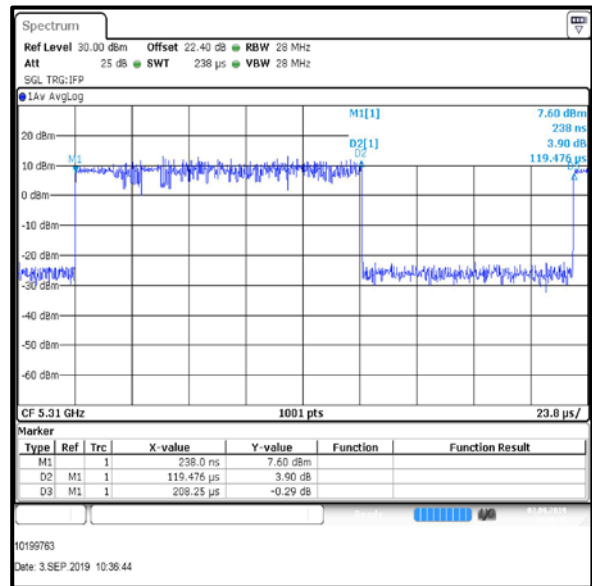

Top Channel

Results: 802.11n / 40 MHz / SISO / 16-QAM / MCS4 / Port 1

Channel	Frequency (MHz)	Pulse Duration (ms)	Period (ms)	Duty Cycle (dB)
Bottom	5270	0.1195	0.1911	2.0
Top	5310	0.1195	0.1921	2.1

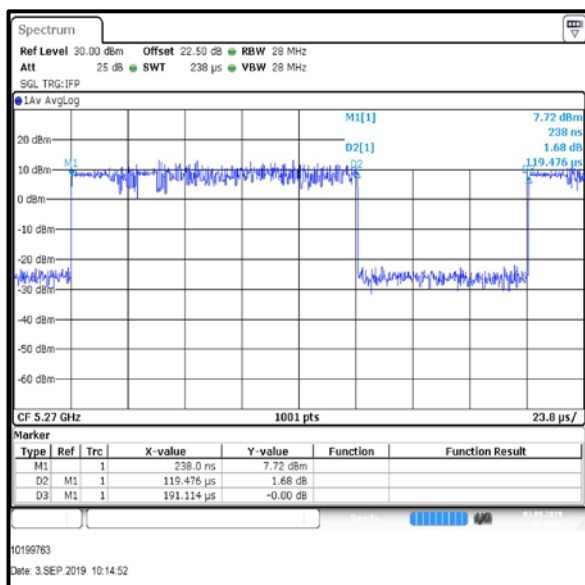

Bottom Channel

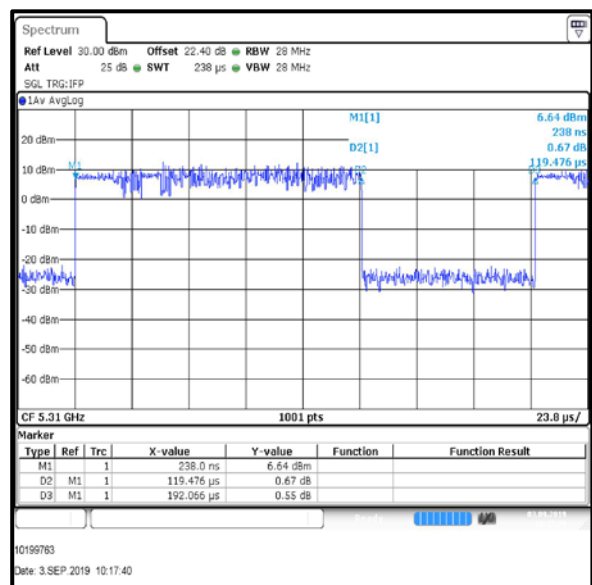

Top Channel

Transmitter Duty Cycle (continued)

Results: 802.11ac / 80 MHz / SISO / QPSK / MCS1x1 / Port 1

Channel	Frequency (MHz)	Pulse Duration (ms)	Period (ms)	Duty Cycle (dB)
Single	5290	0.1835	0.2741	1.7

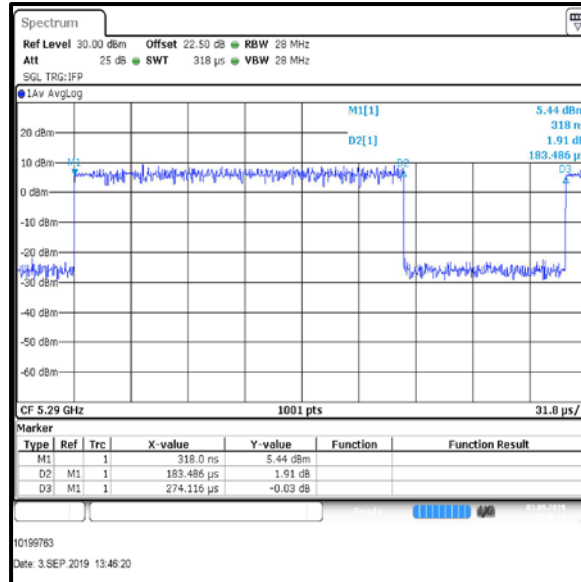

Single Channel

Results: 802.11ac / 80 MHz / SISO / 256-QAM / MCS8x1 / Port 1

Channel	Frequency (MHz)	Pulse Duration (ms)	Period (ms)	Duty Cycle (dB)
Single	5290	0.0636	0.1342	3.2

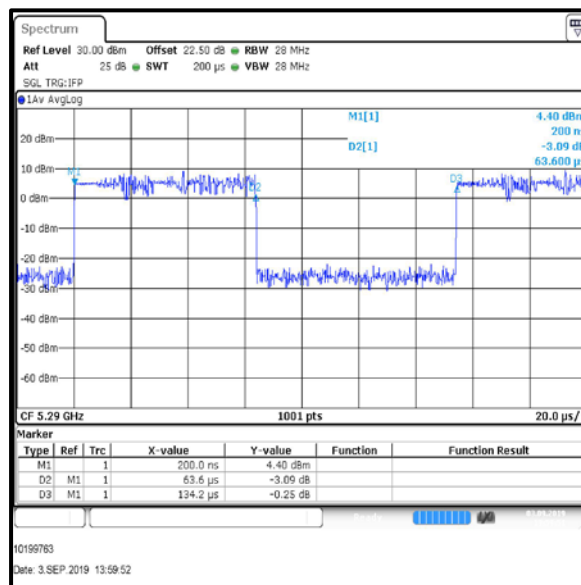

Single Channel

Transmitter Duty Cycle (continued)

Results: 802.11a / 20 MHz / MIMO / 2Tx CDD / 64-QAM / 48 Mbps / Port 1

Channel	Frequency (MHz)	Pulse Duration (ms)	Period (ms)	Duty Cycle (dB)
Bottom	5260	0.1994	0.2991	1.8
Middle	5280	0.1993	0.2902	1.6
Top	5320	0.1995	0.2994	1.8

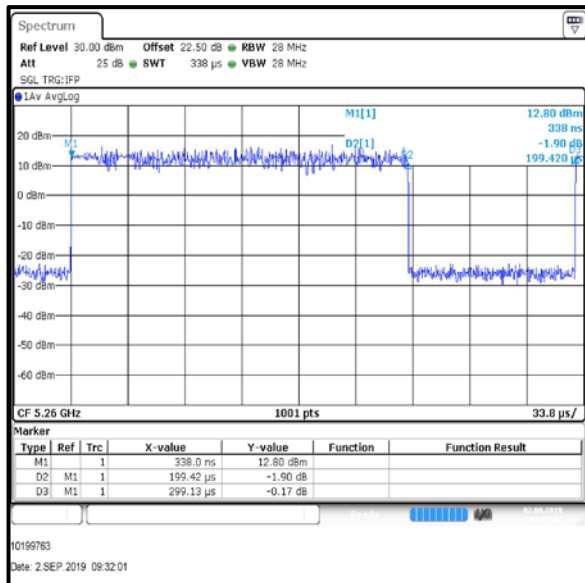

Bottom Channel

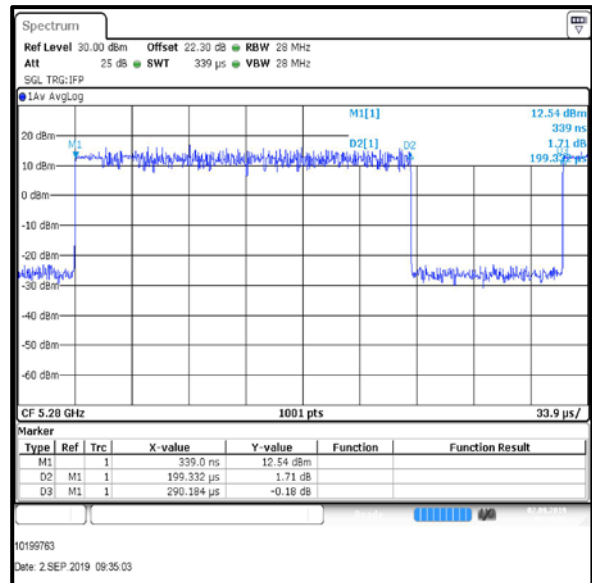

Middle Channel

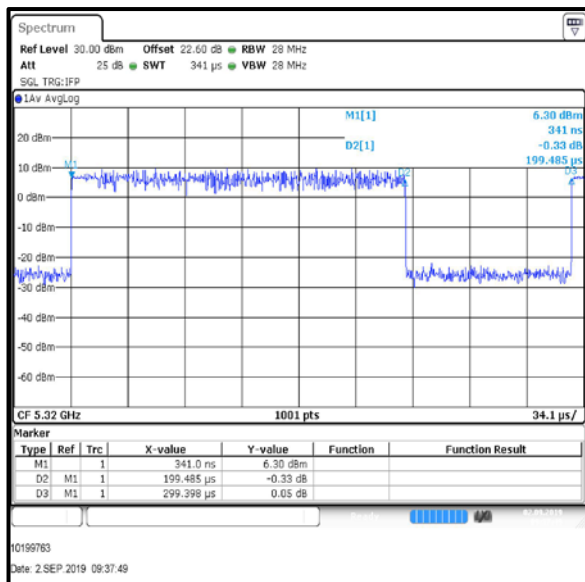

Top Channel

Transmitter Duty Cycle (continued)

Results: 802.11a / 20 MHz / MIMO / 2Tx CDD / 64-QAM / 54 Mbps / Port 1

Channel	Frequency (MHz)	Pulse Duration (ms)	Period (ms)	Duty Cycle (dB)
Bottom	5260	0.1994	0.2700	1.3
Middle	5280	0.1994	0.2822	1.5
Top	5320	0.1994	0.2822	1.5

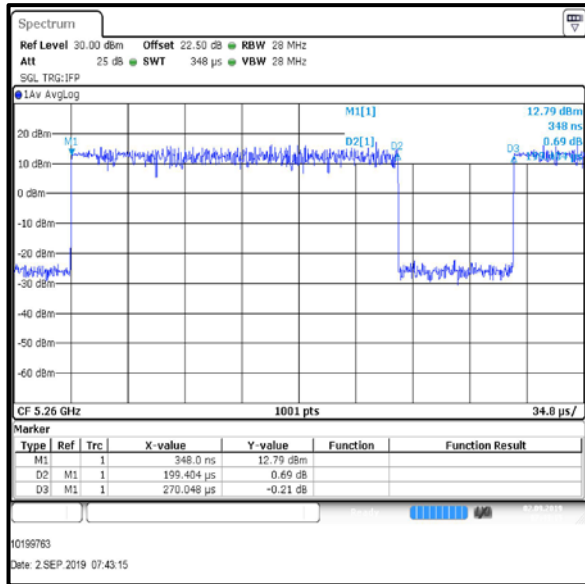

Bottom Channel

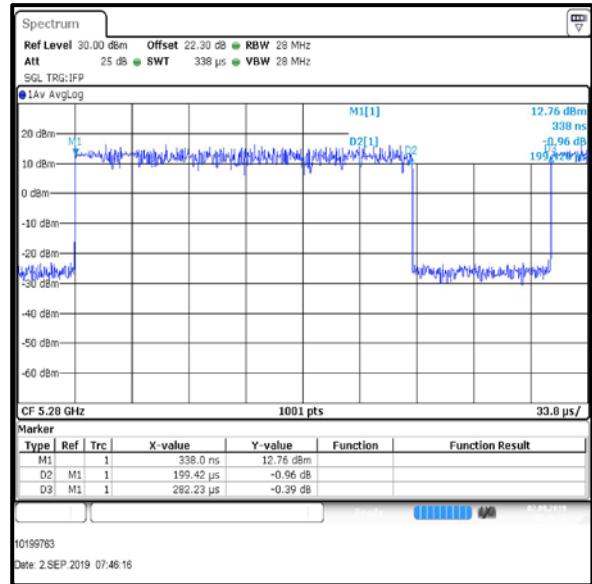

Middle Channel

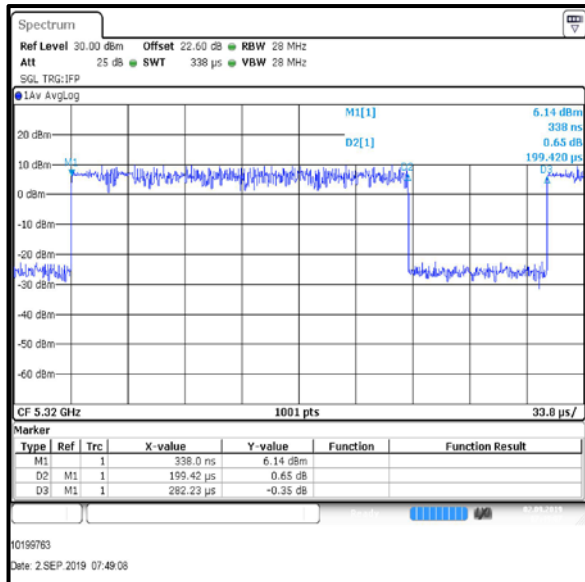

Top Channel

Transmitter Duty Cycle (continued)

Results: 802.11n / 20 MHz / MIMO / 2Tx CDD / BPSK / MCS0 / Port 1

Channel	Frequency (MHz)	Pulse Duration (ms)	Period (ms)	Duty Cycle (dB)
Bottom	5260	0.1994	0.2731	1.4
Middle	5280	0.1994	0.2941	1.7
Top	5320	0.1994	0.2792	1.5

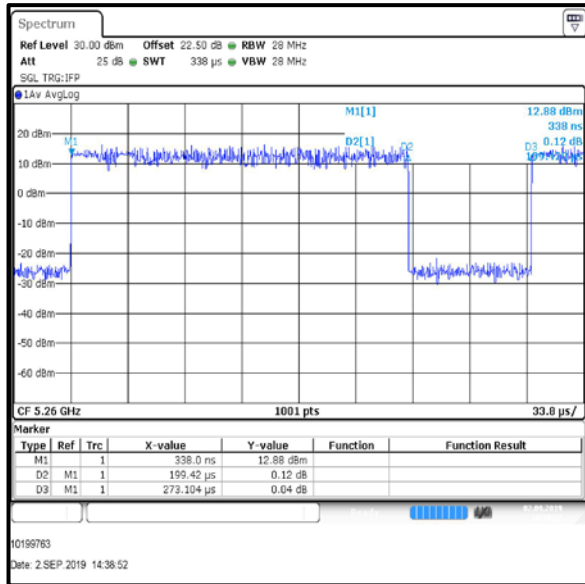

Bottom Channel

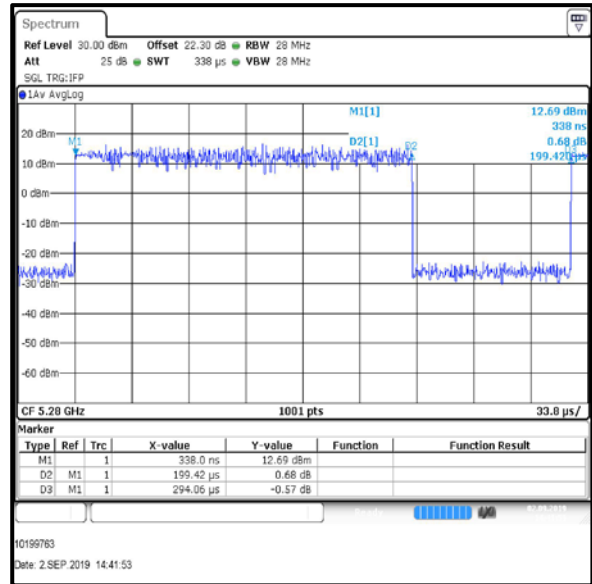

Middle Channel

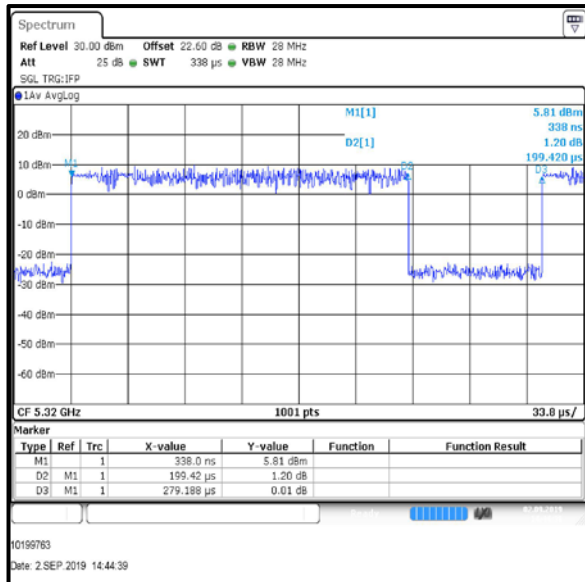

Top Channel

Transmitter Duty Cycle (continued)

Results: 802.11n / 20 MHz / MIMO / 2Tx CDD / 16-QAM / MCS4 / Port 1

Channel	Frequency (MHz)	Pulse Duration (ms)	Period (ms)	Duty Cycle (dB)
Bottom	5260	0.1994	0.2721	1.3
Middle	5280	0.1994	0.2721	1.3
Top	5320	0.1993	0.2702	1.3

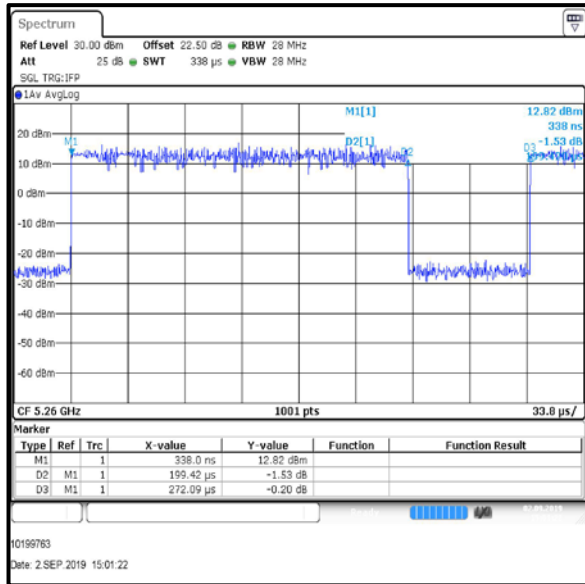

Bottom Channel

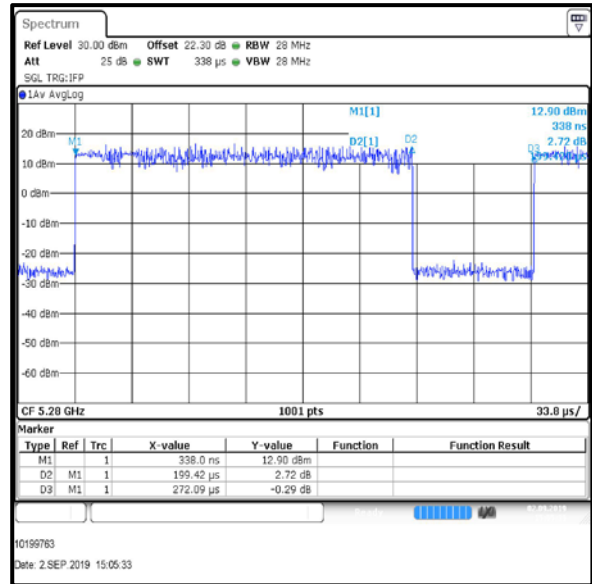

Middle Channel

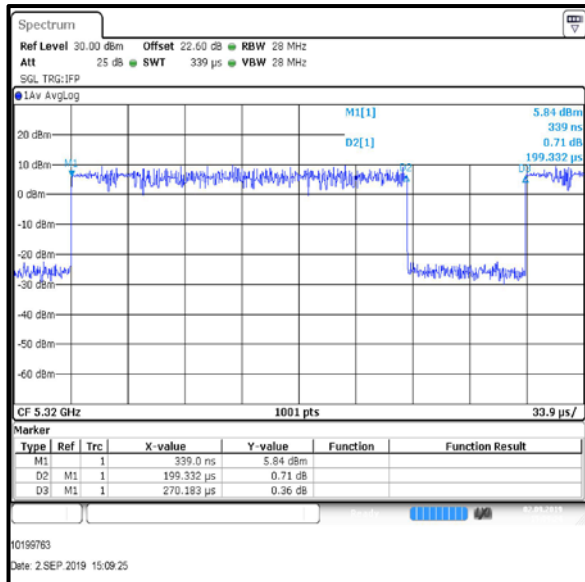

Top Channel

Transmitter Duty Cycle (continued)

Results: 802.11n / 40 MHz / MIMO / 2Tx CDD / 64-QAM / MCS7 / Port 1

Channel	Frequency (MHz)	Pulse Duration (ms)	Period (ms)	Duty Cycle (dB)
Bottom	5270	0.1195	0.2102	2.5
Top	5310	0.1195	0.1991	2.2

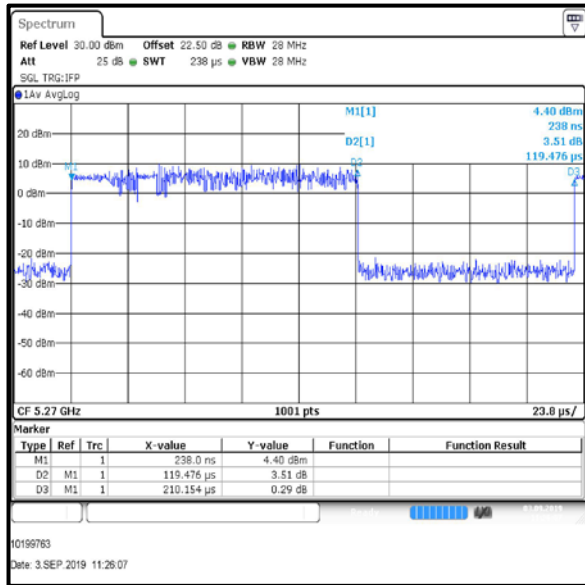

Bottom Channel

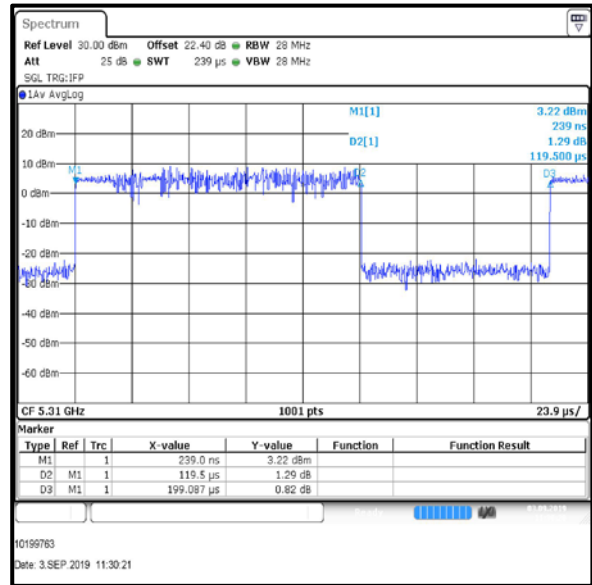

Top Channel

Results: 802.11ac / 80 MHz / MIMO / 2Tx CDD / 64-QAM / MCS5x1 / Port 1

Channel	Frequency (MHz)	Pulse Duration (ms)	Period (ms)	Duty Cycle (dB)
Single	5290	0.0636	0.1361	3.3

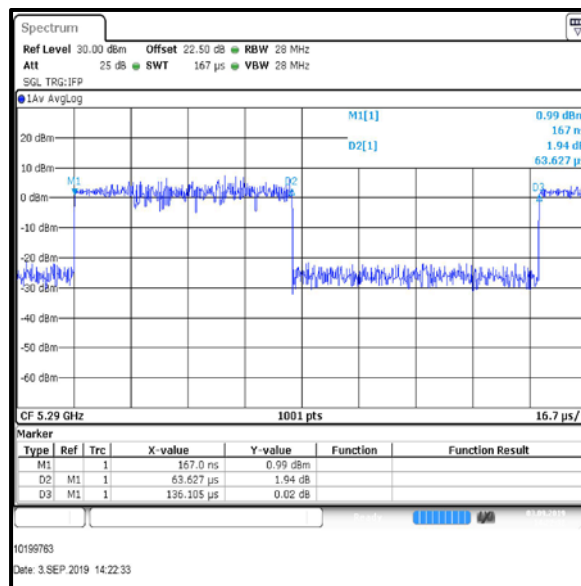

Single Channel

Transmitter Duty Cycle (continued)

Results: 802.11ac / 80 MHz / MIMO / 2Tx CDD / 256-QAM / MCS9x1 / Port 1

Channel	Frequency (MHz)	Pulse Duration (ms)	Period (ms)	Duty Cycle (dB)
Single	5290	0.0556	0.1272	3.6

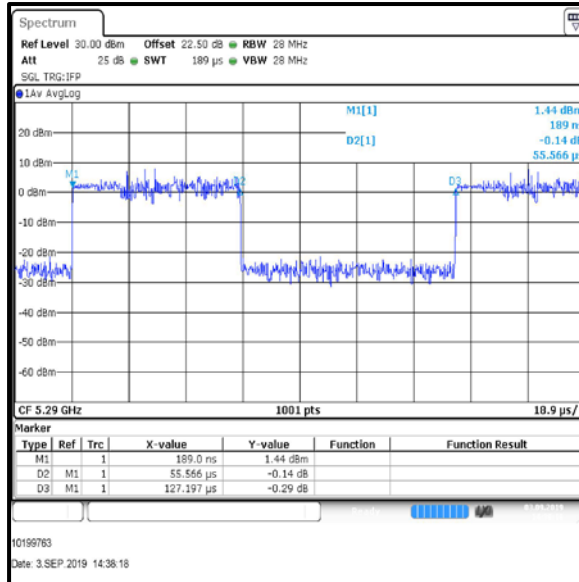

Single Channel

Transmitter Duty Cycle (continued)

Results: 802.11a / 20 MHz / MIMO / 3Tx CDD / BPSK / 9 Mbps / Port 1

Channel	Frequency (MHz)	Pulse Duration (ms)	Period (ms)	Duty Cycle (dB)
Bottom	5260	0.1994	0.2701	1.3
Middle	5280	0.1995	0.2814	1.5
Top	5320	0.1995	0.2701	1.3

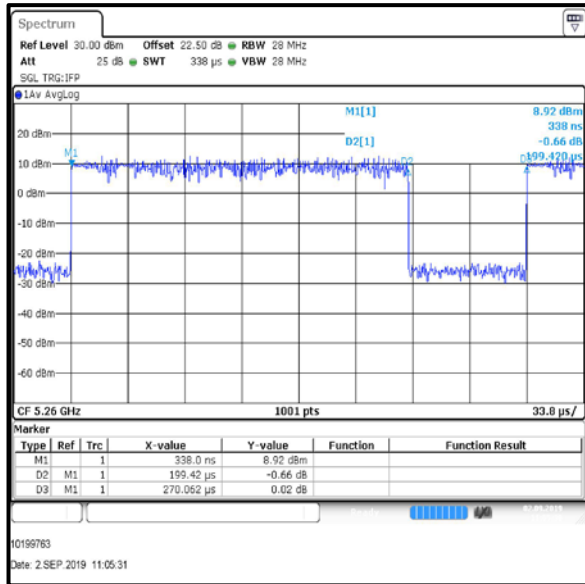

Bottom Channel

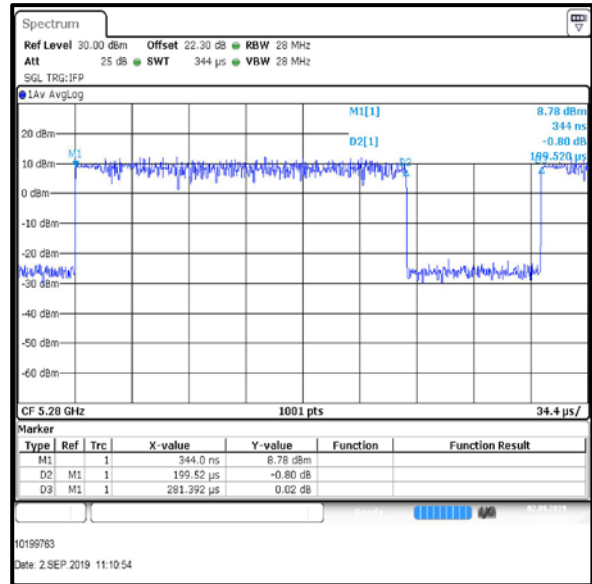

Middle Channel

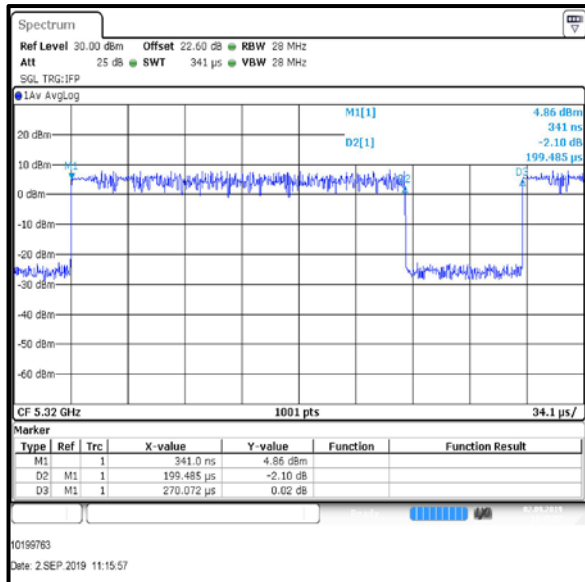

Top Channel

Transmitter Duty Cycle (continued)

Results: 802.11a / 20 MHz / MIMO / 3Tx CDD / QPSK / 12 Mbps / Port 1

Channel	Frequency (MHz)	Pulse Duration (ms)	Period (ms)	Duty Cycle (dB)
Bottom	5260	0.1994	0.2802	1.5
Middle	5280	0.1996	0.2843	1.5
Top	5320	0.1994	0.2941	1.7

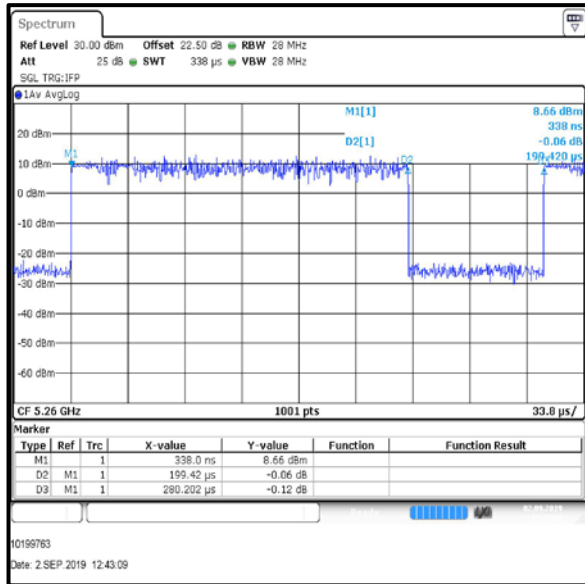

Bottom Channel

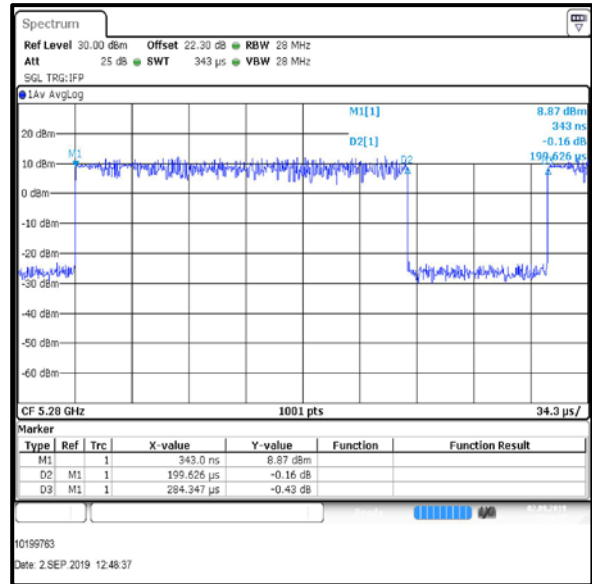

Middle Channel

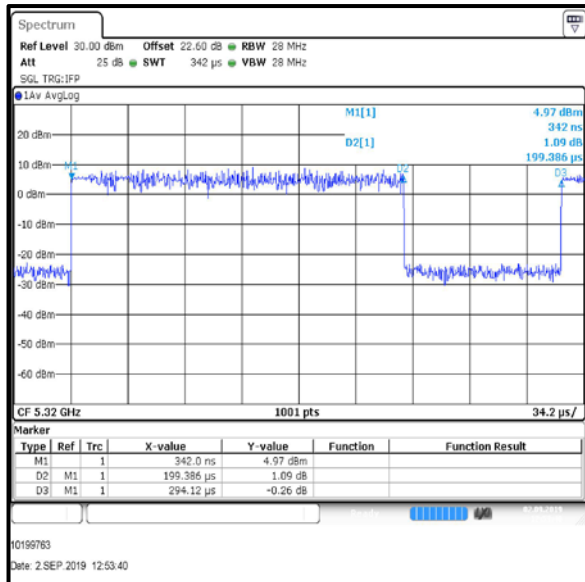

Top Channel

Transmitter Duty Cycle (continued)

Results: 802.11n / 20 MHz / MIMO / 3Tx CDD / 16-QAM / MCS3 / Port 1

Channel	Frequency (MHz)	Pulse Duration (ms)	Period (ms)	Duty Cycle (dB)
Bottom	5260	0.1995	0.2902	1.6
Middle	5280	0.1995	0.2841	1.5
Top	5320	0.1994	0.2903	1.6

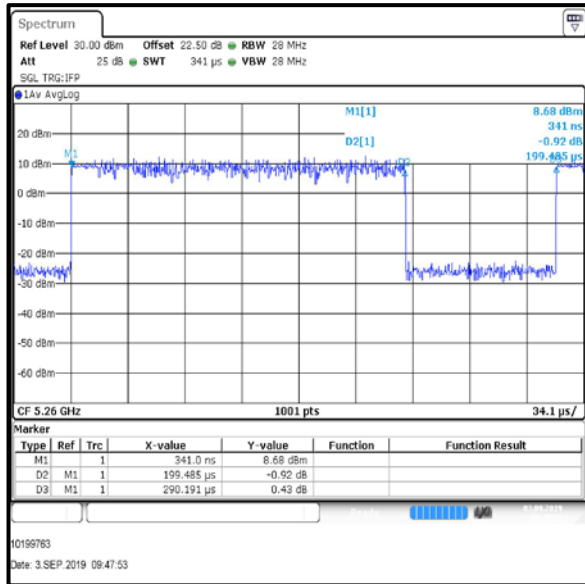

Bottom Channel

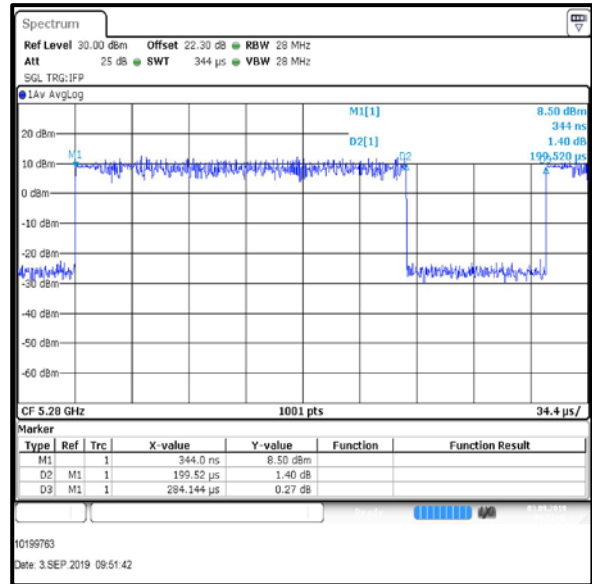

Middle Channel

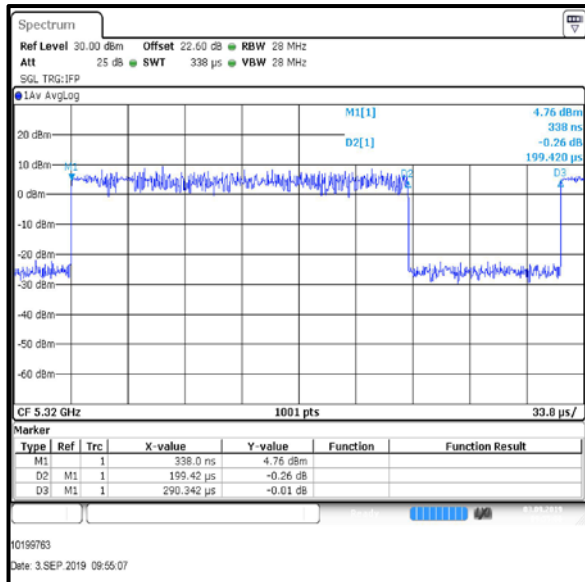

Top Channel

Transmitter Duty Cycle (continued)

Results: 802.11n / 20 MHz / MIMO / 3Tx CDD / 64-QAM / MCS7 / Port 1

Channel	Frequency (MHz)	Pulse Duration (ms)	Period (ms)	Duty Cycle (dB)
Bottom	5260	0.1994	0.2822	1.5
Middle	5280	0.1994	0.2944	1.7
Top	5320	0.1994	0.2991	1.8

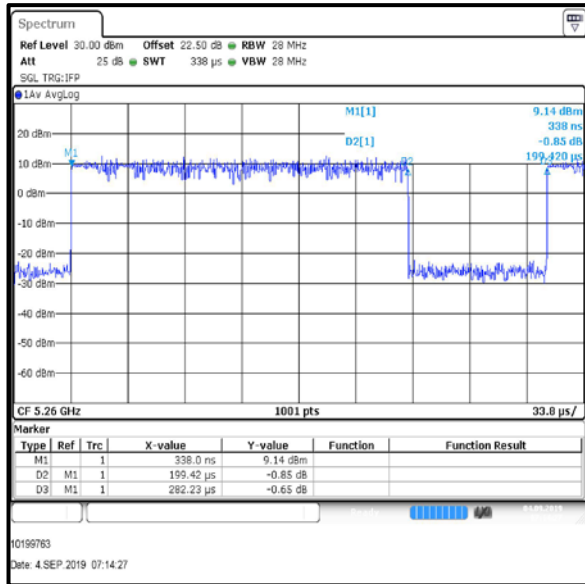

Bottom Channel

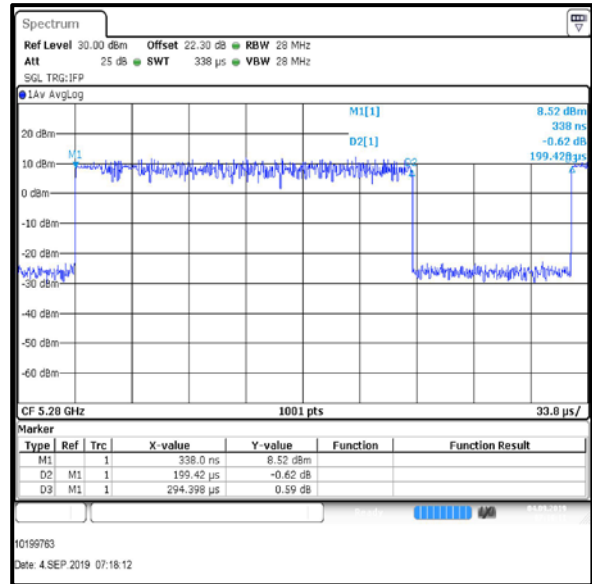

Middle Channel

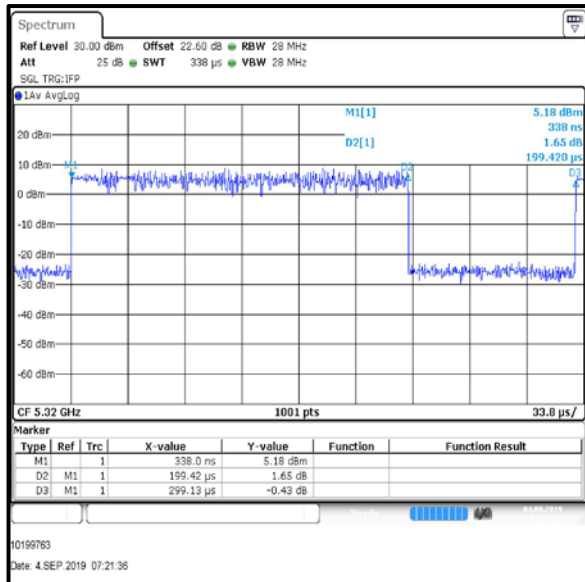

Top Channel

Transmitter Duty Cycle (continued)

Results: 802.11n / 40 MHz / MIMO / 3Tx CDD / 16-QAM / MCS3 / Port 1

Channel	Frequency (MHz)	Pulse Duration (ms)	Period (ms)	Duty Cycle (dB)
Bottom	5270	0.1189	0.1953	2.2
Top	5310	0.1195	0.2102	2.5

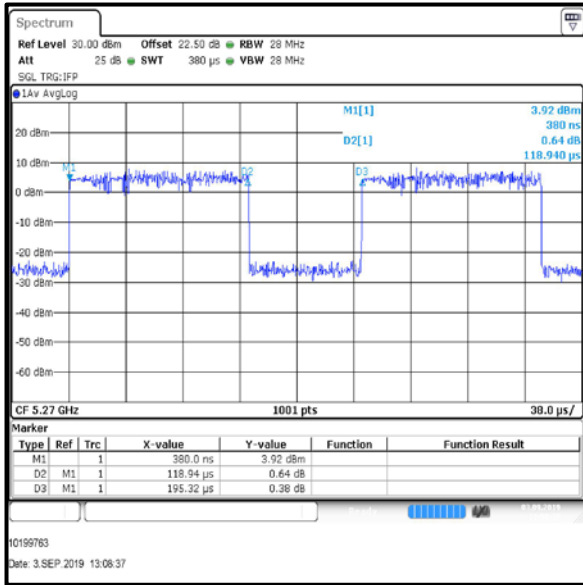

Bottom Channel

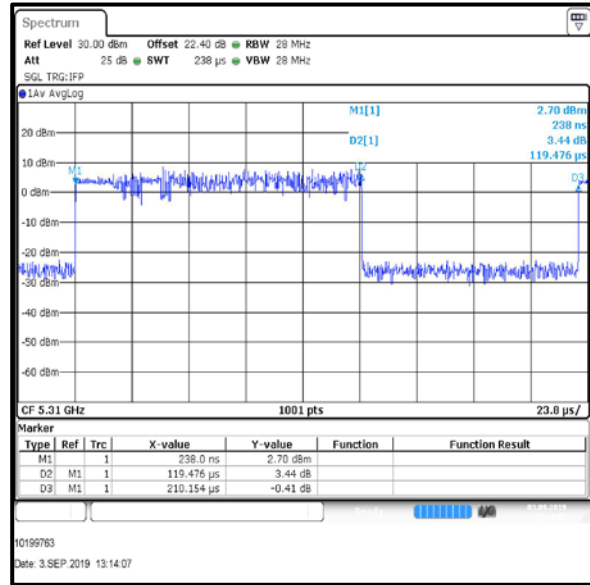

Top Channel

Results: 802.11n / 40 MHz / MIMO / 3Tx CDD / 64-QAM / MCS5 / Port 1

Channel	Frequency (MHz)	Pulse Duration (ms)	Period (ms)	Duty Cycle (dB)
Bottom	5270	0.1195	0.2104	2.5
Top	5310	0.1195	0.1933	2.1

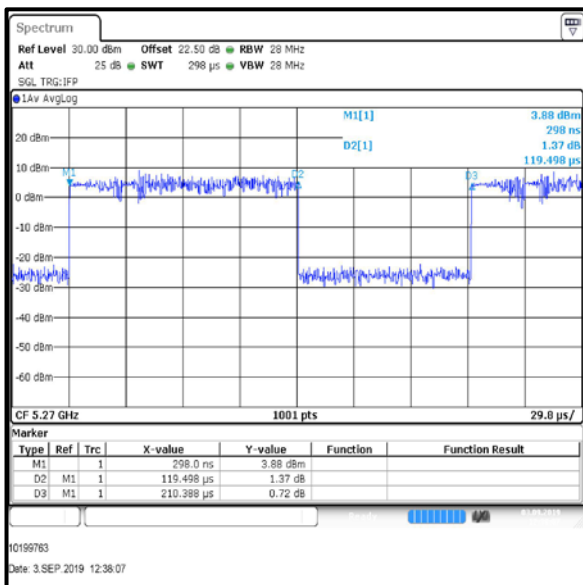

Bottom Channel

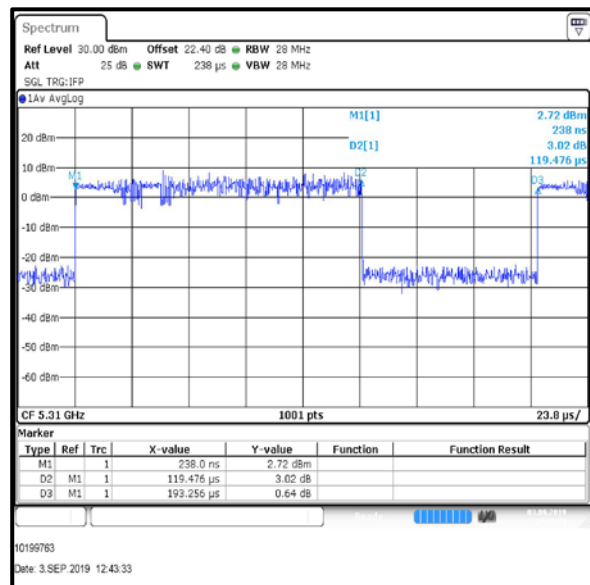

Top Channel

Transmitter Duty Cycle (continued)

Results: 802.11ac / 80 MHz / MIMO / 3Tx CDD / QPSK / MCS1x1 / Port 1

Channel	Frequency (MHz)	Pulse Duration (ms)	Period (ms)	Duty Cycle (dB)
Single	5290	0.0995	0.1702	2.3

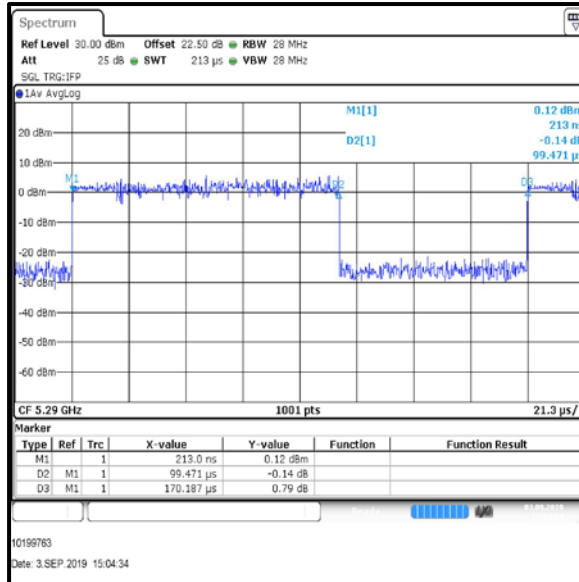

Single Channel

Results: 802.11ac / 80 MHz / MIMO / 3Tx CDD / QPSK / MCS2x1 / Port 1

Channel	Frequency (MHz)	Pulse Duration (ms)	Period (ms)	Duty Cycle (dB)
Single	5290	0.0836	0.1662	3.0

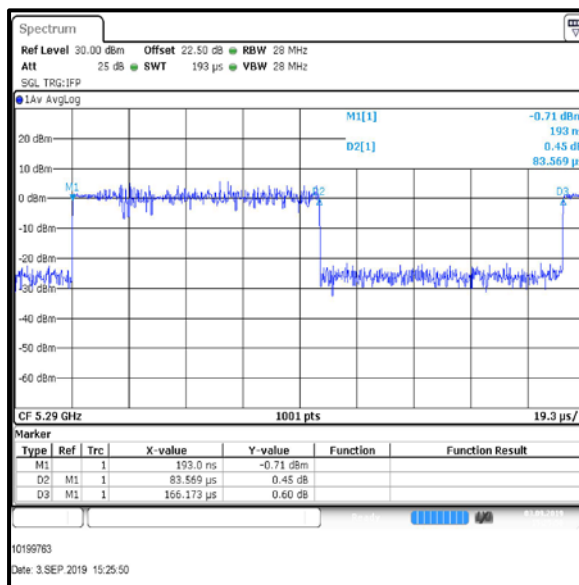

Single Channel

Transmitter Duty Cycle (continued)

Results: 802.11a / 20 MHz / MIMO / 4Tx CDD / QPSK / 12 Mbps / Port 1

Channel	Frequency (MHz)	Pulse Duration (ms)	Period (ms)	Duty Cycle (dB)
Bottom	5260	0.6981	0.7878	0.5
Middle	5280	0.7023	0.7948	0.5
Top	5320	0.7028	0.7786	0.4

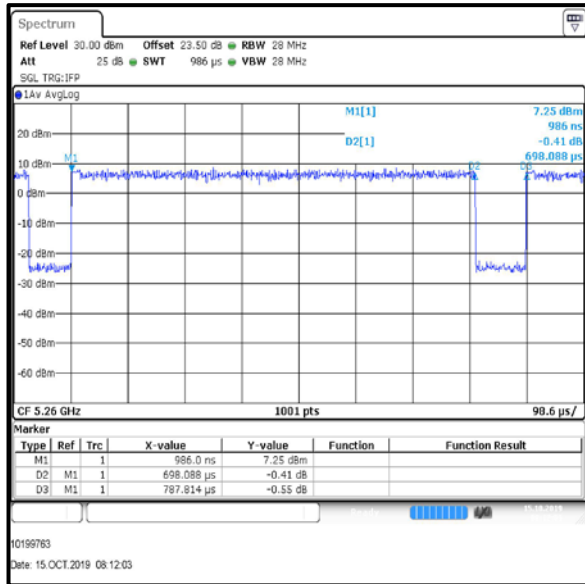

Bottom Channel

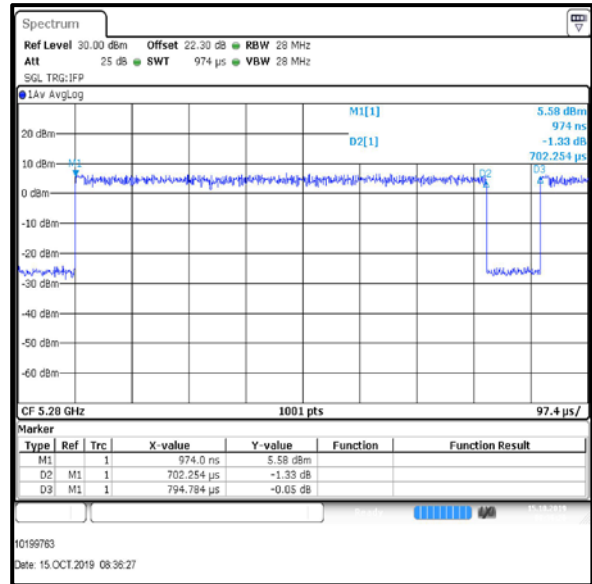

Middle Channel

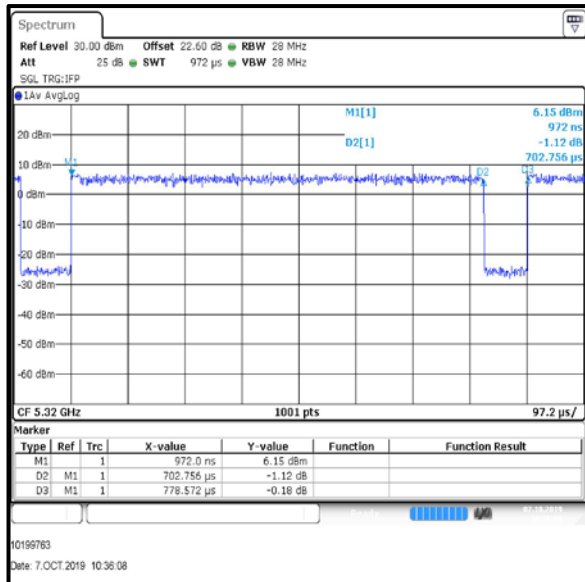

Top Channel

Transmitter Duty Cycle (continued)

Results: 802.11n / 20 MHz / MIMO / 4Tx CDD / QPSK / MCS1 / Port 1

Channel	Frequency (MHz)	Pulse Duration (ms)	Period (ms)	Duty Cycle (dB)
Bottom	5260	0.6665	0.7416	0.5
Middle	5280	0.6662	0.7430	0.5
Top	5320	0.6662	0.7586	0.6

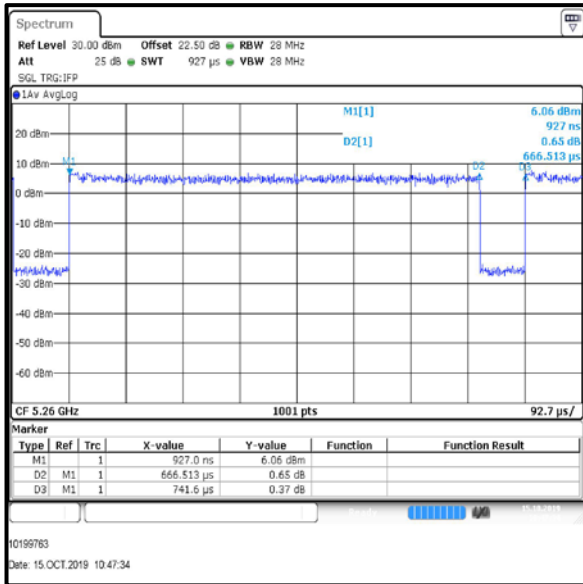

Bottom Channel

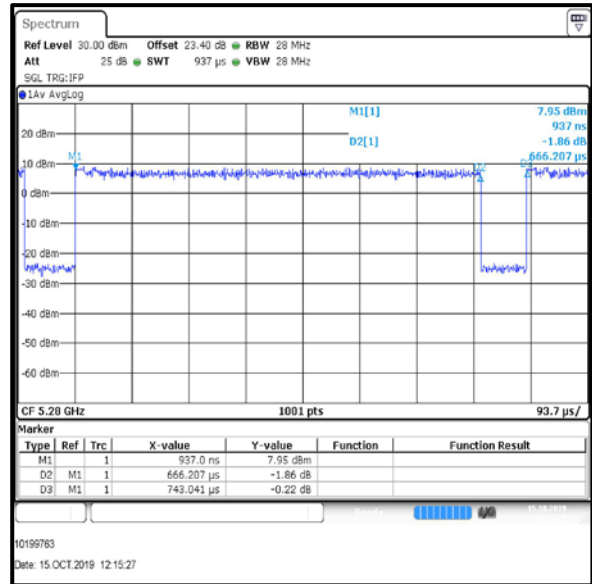

Middle Channel

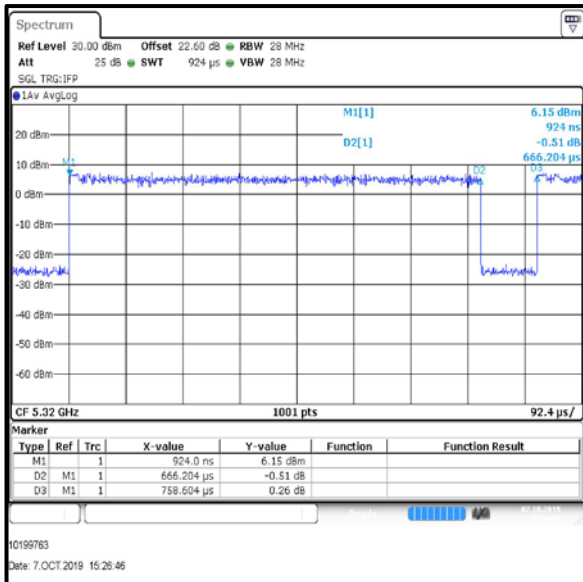

Top Channel

Transmitter Duty Cycle (continued)

Results: 802.11n / 20 MHz / MIMO / 4Tx CDD / QPSK / MCS2 / Port 1

Channel	Frequency (MHz)	Pulse Duration (ms)	Period (ms)	Duty Cycle (dB)
Bottom	5260	0.4590	0.5397	0.7
Middle	5280	0.4589	0.5364	0.7
Top	5320	0.4590	0.5436	0.7

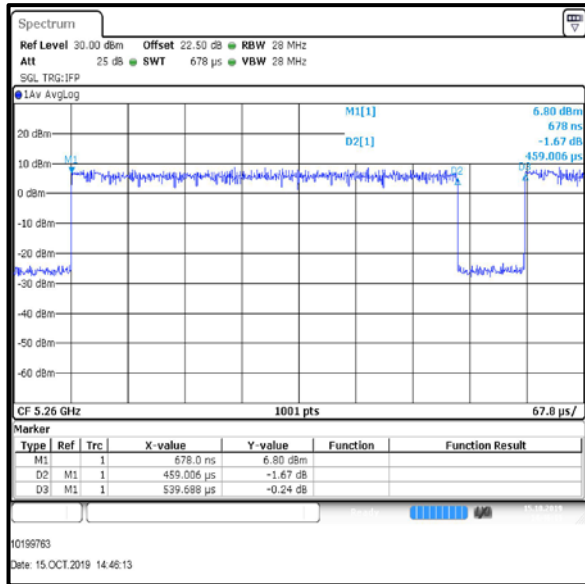

Bottom Channel

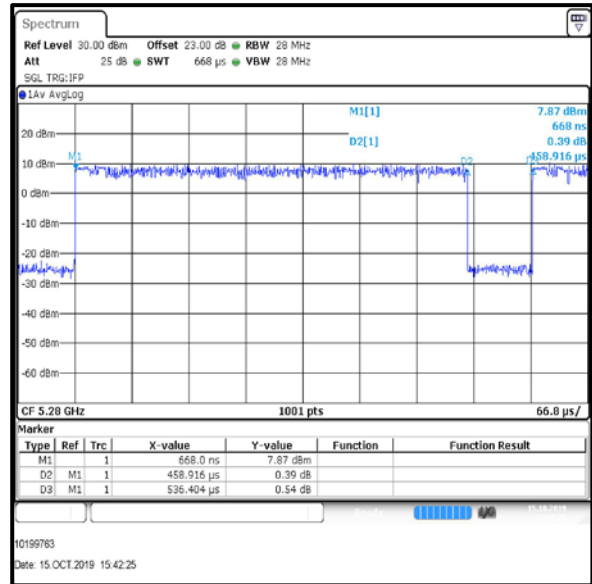

Middle Channel

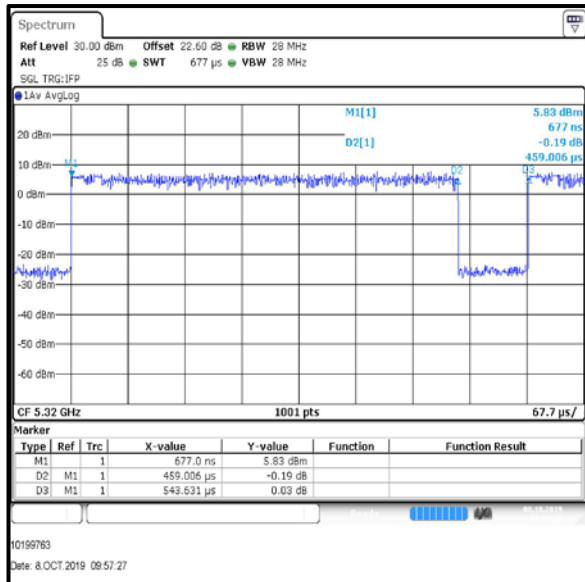

Top Channel

Transmitter Duty Cycle (continued)

Results: 802.11n / 40 MHz / MIMO / 4Tx CDD / 16-QAM / MCS3 / Port 1

Channel	Frequency (MHz)	Pulse Duration (ms)	Period (ms)	Duty Cycle (dB)
Bottom	5270	0.1873	0.2581	1.4
Top	5310	0.1873	0.2584	1.4

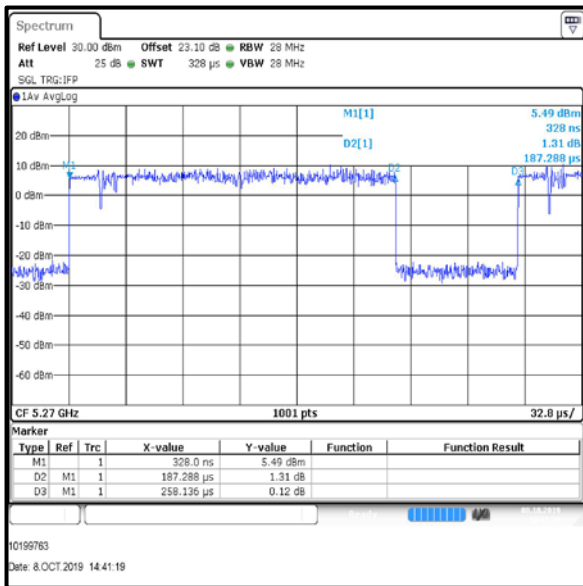

Bottom Channel

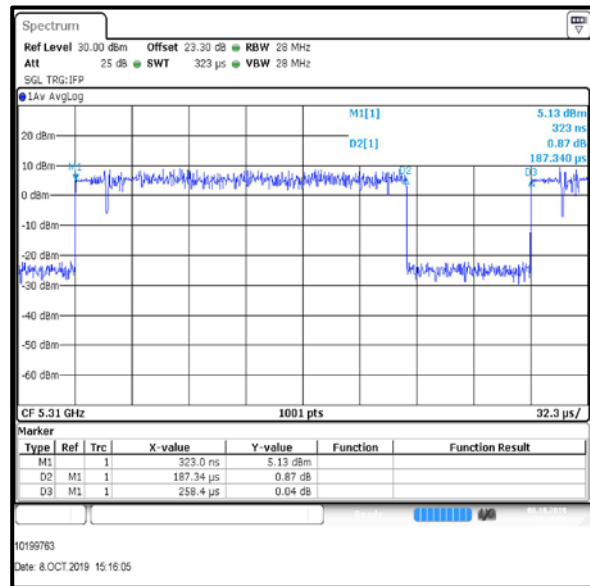

Top Channel

Results: 802.11n / 40 MHz / MIMO / 4Tx CDD / 64-QAM / MCS7 / Port 1

Channel	Frequency (MHz)	Pulse Duration (ms)	Period (ms)	Duty Cycle (dB)
Bottom	5270	0.0995	0.1753	2.5
Top	5310	0.0996	0.1703	2.3

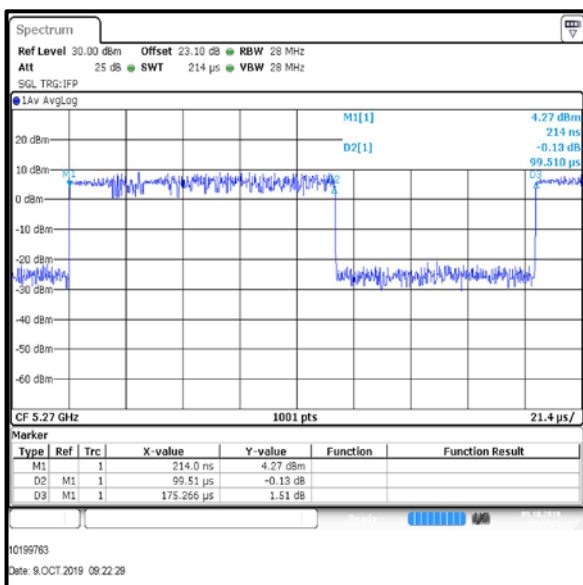

Bottom Channel

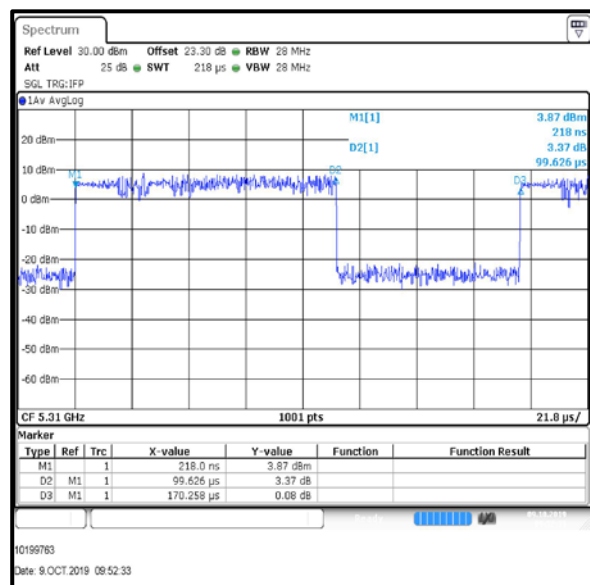

Top Channel

Transmitter Duty Cycle (continued)

Results: 802.11ac / 80 MHz / MIMO / 4Tx CDD / 16-QAM / MCS3x1 / Port 1

Channel	Frequency (MHz)	Pulse Duration (ms)	Period (ms)	Duty Cycle (dB)
Single	5290	0.0715	0.1421	3.0

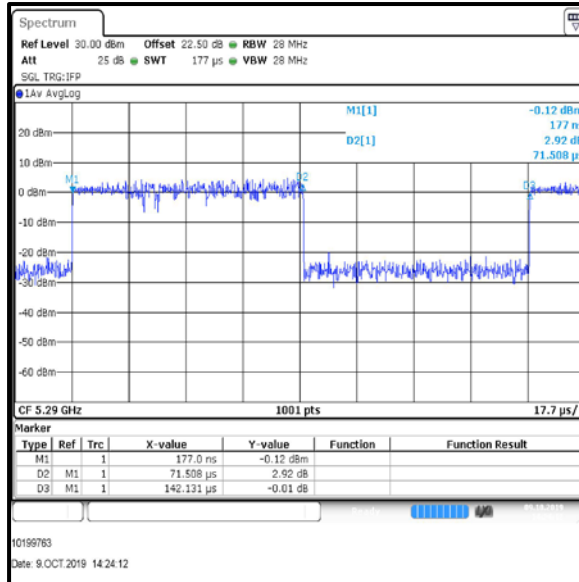

Single Channel

Results: 802.11ac / 80 MHz / MIMO / 4Tx CDD / 64-QAM / MCS6x1 / Port 1

Channel	Frequency (MHz)	Pulse Duration (ms)	Period (ms)	Duty Cycle (dB)
Single	5290	0.0597	0.1302	3.4

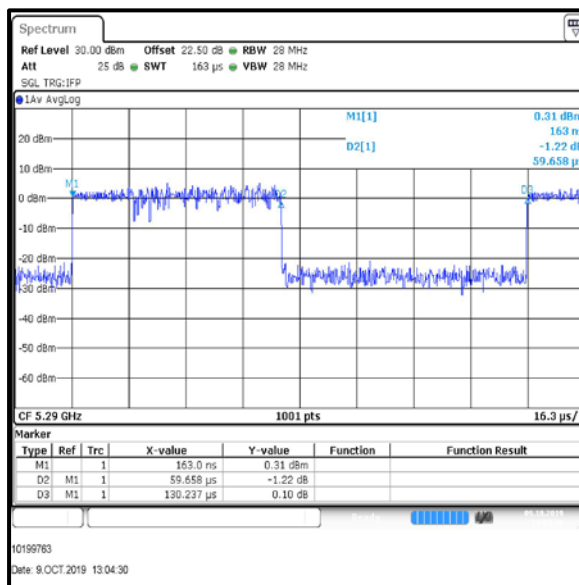

Single Channel

Transmitter Duty Cycle (continued)

4.1.2. 5.47-5.725 GHz band

Results: 802.11a / 20 MHz / SISO / 64-QAM / 48 Mbps / Port 1

Channel	Frequency (MHz)	Pulse Duration (ms)	Period (ms)	Duty Cycle (dB)
Bottom	5500	0.1994	0.2903	1.6
Middle	5580	0.1994	0.2914	1.6
Top	5700	0.1993	0.2993	1.8

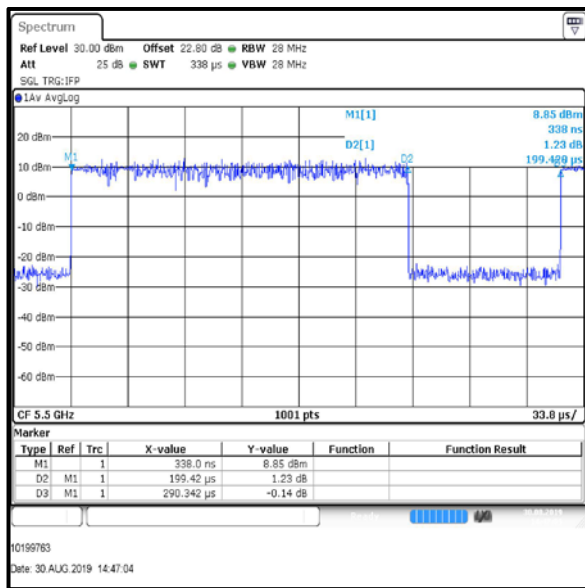

Bottom Channel

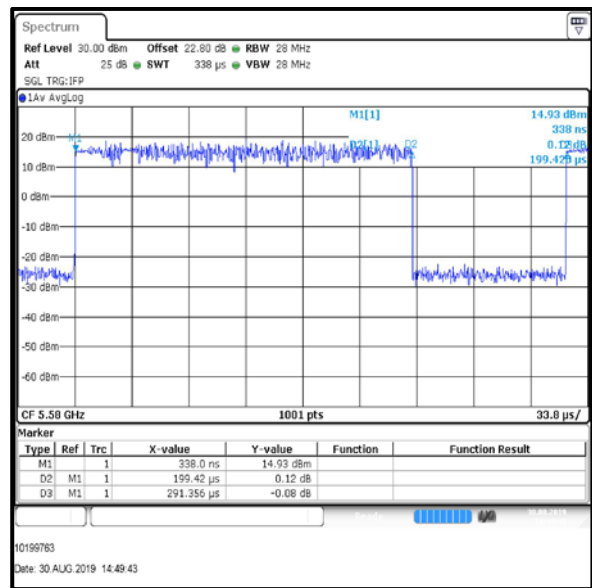

Middle Channel

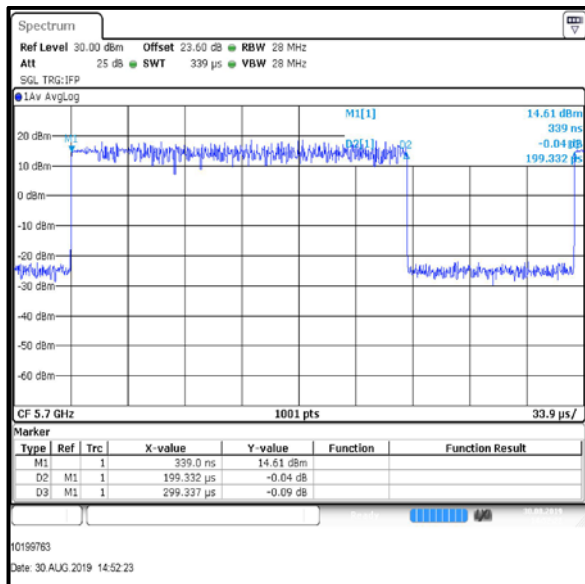

Top Channel

Transmitter Duty Cycle (continued)

Results: 802.11a / 20 MHz / SISO / 64-QAM / 54 Mbps / Port 1

Channel	Frequency (MHz)	Pulse Duration (ms)	Period (ms)	Duty Cycle (dB)
Bottom	5500	0.1994	0.2843	1.5
Middle	5580	0.1994	0.2761	1.4
Top	5700	0.1993	0.2793	1.5

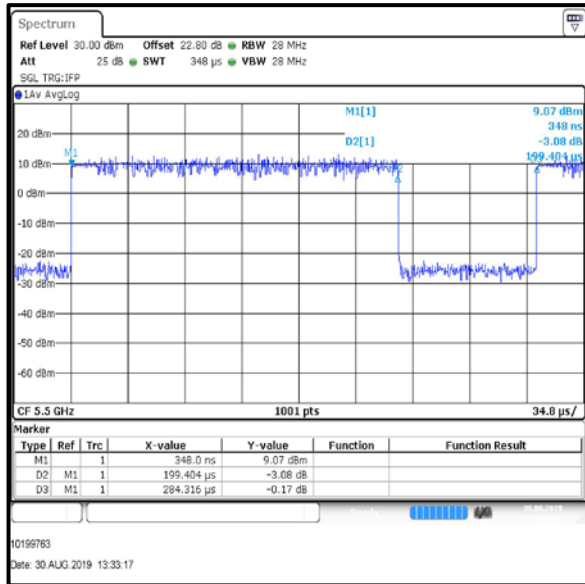

Bottom Channel

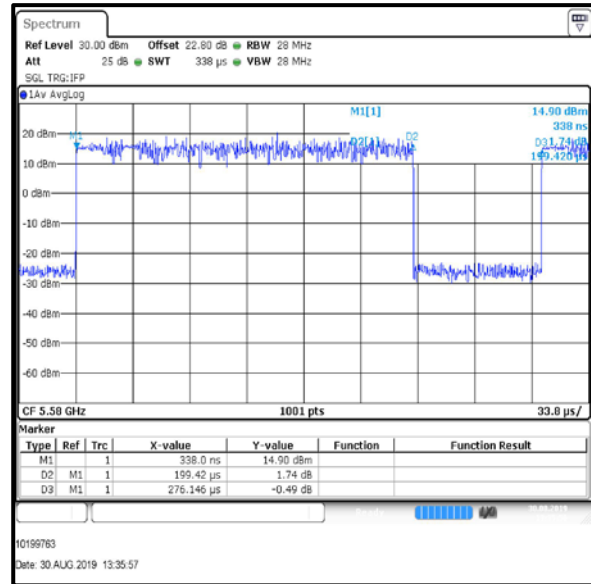

Middle Channel

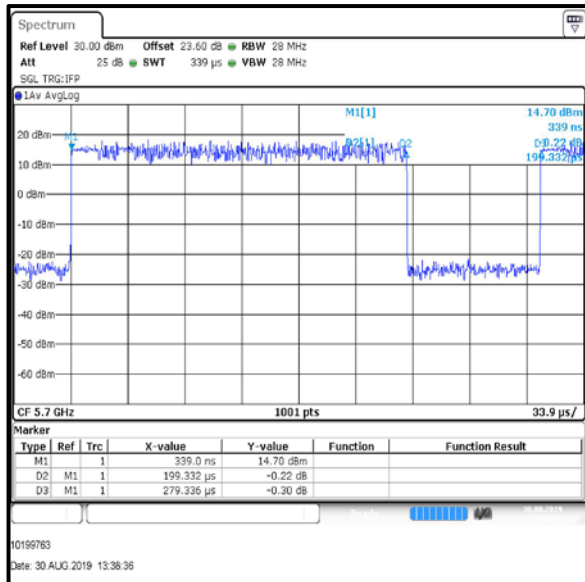

Top Channel

Transmitter Duty Cycle (continued)

Results: 802.11n / 20 MHz / SISO / QPSK / MCS2 / Port 1

Channel	Frequency (MHz)	Pulse Duration (ms)	Period (ms)	Duty Cycle (dB)
Bottom	5500	0.1993	0.2893	1.6
Middle	5580	0.1994	0.2702	1.3
Top	5700	0.1993	0.2732	1.4

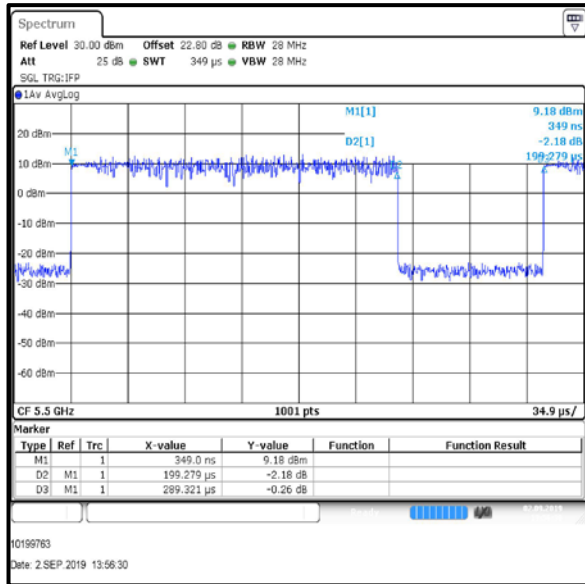

Bottom Channel

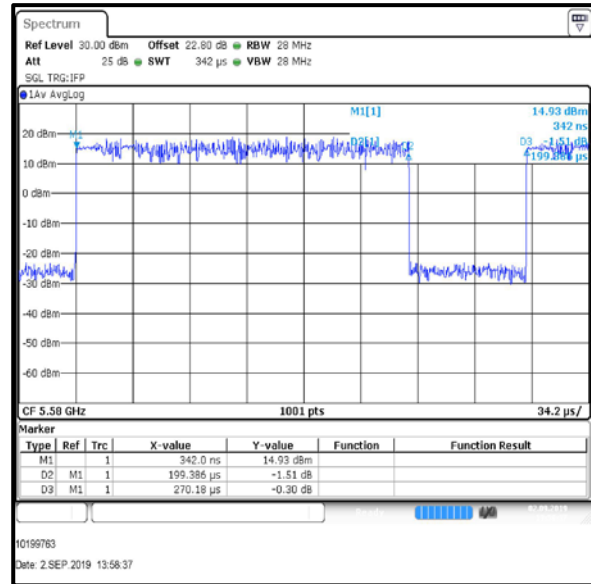

Middle Channel

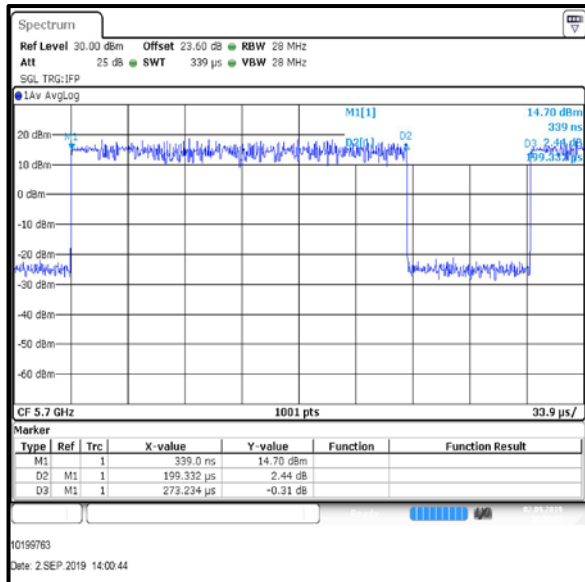

Top Channel

Transmitter Duty Cycle (continued)

Results: 802.11n / 20 MHz / SISO / 64-QAM / MCS6 / Port 1

Channel	Frequency (MHz)	Pulse Duration (ms)	Period (ms)	Duty Cycle (dB)
Bottom	5500	0.1994	0.2702	1.3
Middle	5580	0.1994	0.2811	1.5
Top	5700	0.1993	0.2783	1.4

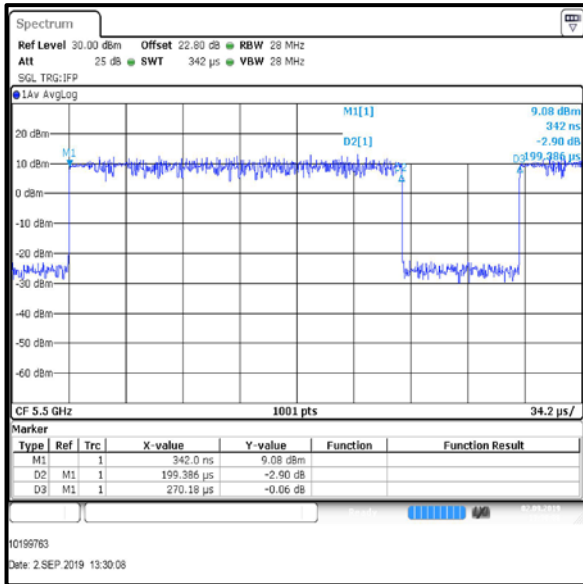

Bottom Channel

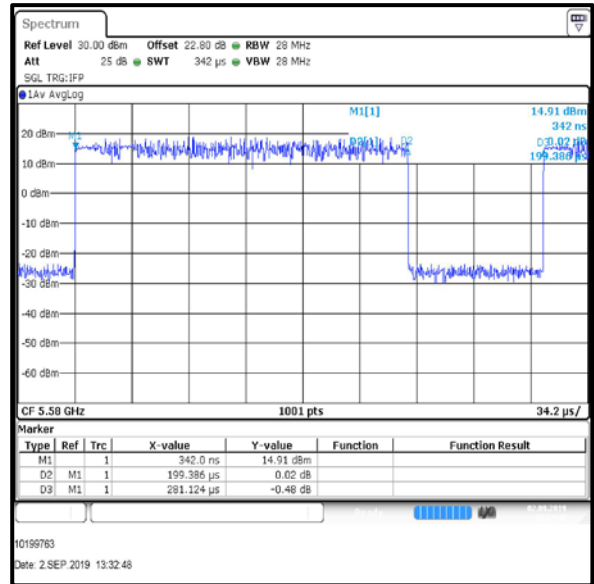

Middle Channel

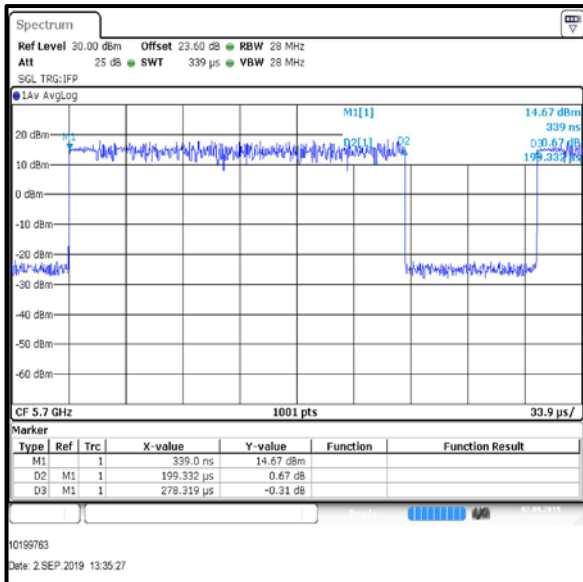

Top Channel