

Function	Signal name	IO	Signal form and level	Comment
Analog Audio interface	VMIC	O	$V_{Omin} = 2.4V$ $V_{Otyp} = 2.5V$ $V_{Omax} = 2.6V$ $I_{max} = 2mA$	Microphone supply for customer feeding circuits
	EPP2	O	1.0954Vpp (differential) typical	The audio output can directly operate a 32-Ohm-loudspeaker. If unused keep pins open.
	EPN2	O	3.4Vpp differential maximal Audio mode TBD Measurement conditions TBD Minimum differential resp. single ended load 27 Ohms	
	EPP1	O	1.0954Vpp (differential) typical	The audio output can directly operate an 8-Ohm-loudspeaker. If unused keep pins open.
	EPN1	O	6.0 Vp-p differential maximal Audio mode TBD Measurement conditions TBD Minimum differential resp. single ended load 7.5 Ohms	
	MICP1	I	Full Scale Input Voltage 1.578 Vpp	Balanced or single ended microphone or line inputs with external feeding circuit (using VMIC and AGND). If unused keep pins open.
	MICN1	I	0dBm0 Input Voltage 1.0954 Vpp	
	MICP2	I	At MICNx, apply external bias from 1.0V to 1.6V.	
	MICN2	I	Audio mode TBD Measurement conditions TBD	
	AGND			Analog Ground

## 5.4 Electrostatic Discharge

The GSM engine is not protected against Electrostatic Discharge (ESD) in general. Consequently, it is subject to ESD handling precautions that typically apply to ESD sensitive components. Proper ESD handling and packaging procedures must be applied throughout the processing, handling and operation of any application that incorporates a MC75 module.

*Special ESD protection provided on MC75:*

Antenna interface: one spark discharge line (spark gap)

SIM interface: clamp diodes for protection against overvoltage.

The remaining ports of MC75 are not accessible to the user of the final product (since they are installed within the device) and therefore, are only protected according to the "Human Body Model" requirements.

MC75 has been tested according to the EN 61000-4-2 standard. The measured values can be gathered from the following table.

Table 17: Measured electrostatic values

Specification / Requirements	Contact discharge	Air discharge
<b>ETSI EN 301 489-7</b>		
ESD at SIM port	± 4kV	± 8kV
ESD at antenna port	± 4kV	± 8kV
<b>Human Body Model</b> (Test conditions: 1.5 kΩ, 100 pF)		
ESD at USB interface	± 1kV	± 1kV
ESD at SD card interface	± 1kV	± 1kV
ESD at all other interfaces	± 1kV	± 1kV

Note: Please note that the values may vary with the individual application design. For example, it matters whether or not the application platform is grounded over external devices like a computer or other equipment, such as the Siemens reference application described in Chapter 8.

## 5.5 Reliability Characteristics

The test conditions stated below are an extract of the complete test specifications.

Table 18: Summary of reliability test conditions

Type of test	Conditions	Standard
Vibration	Frequency range: 10-20 Hz; acceleration: 3.1mm amplitude Frequency range: 20-500 Hz; acceleration: 5g Duration: 2h per axis = 10 cycles; 3 axes	DIN IEC 68-2-6
Shock half-sinus	Acceleration: 500g Shock duration: 1msec 1 shock per axis 6 positions ( $\pm$ x, y and z)	DIN IEC 68-2-27
Dry heat	Temperature: $+70 \pm 2^{\circ}\text{C}$ Test duration: 16 h Humidity in the test chamber: $< 50\%$	EN 60068-2-2 Bb ETS 300019-2-7
Temperature change (shock)	Low temperature: $-40^{\circ}\text{C} \pm 2^{\circ}\text{C}$ High temperature: $+85^{\circ}\text{C} \pm 2^{\circ}\text{C}$ Changeover time: $< 30\text{s}$ (dual chamber system) Test duration: 1 h Number of repetitions: 100	DIN IEC 68-2-14 Na ETS 300019-2-7
Damp heat cyclic	High temperature: $+55^{\circ}\text{C} \pm 2^{\circ}\text{C}$ Low temperature: $+25^{\circ}\text{C} \pm 2^{\circ}\text{C}$ Humidity: $93\% \pm 3\%$ Number of repetitions: 6 Test duration: 12h + 12h	DIN IEC 68-2-30 Db ETS 300019-2-5
Cold (constant exposure)	Temperature: $-40 \pm 2^{\circ}\text{C}$ Test duration: 16 h	DIN IEC 68-2-1

## 6 Mechanics

### 6.1 Mechanical Dimensions of MC75

Figure 35 shows the top view of MC75 and provides an overview of the board's mechanical dimensions. For further details see Figure 36.

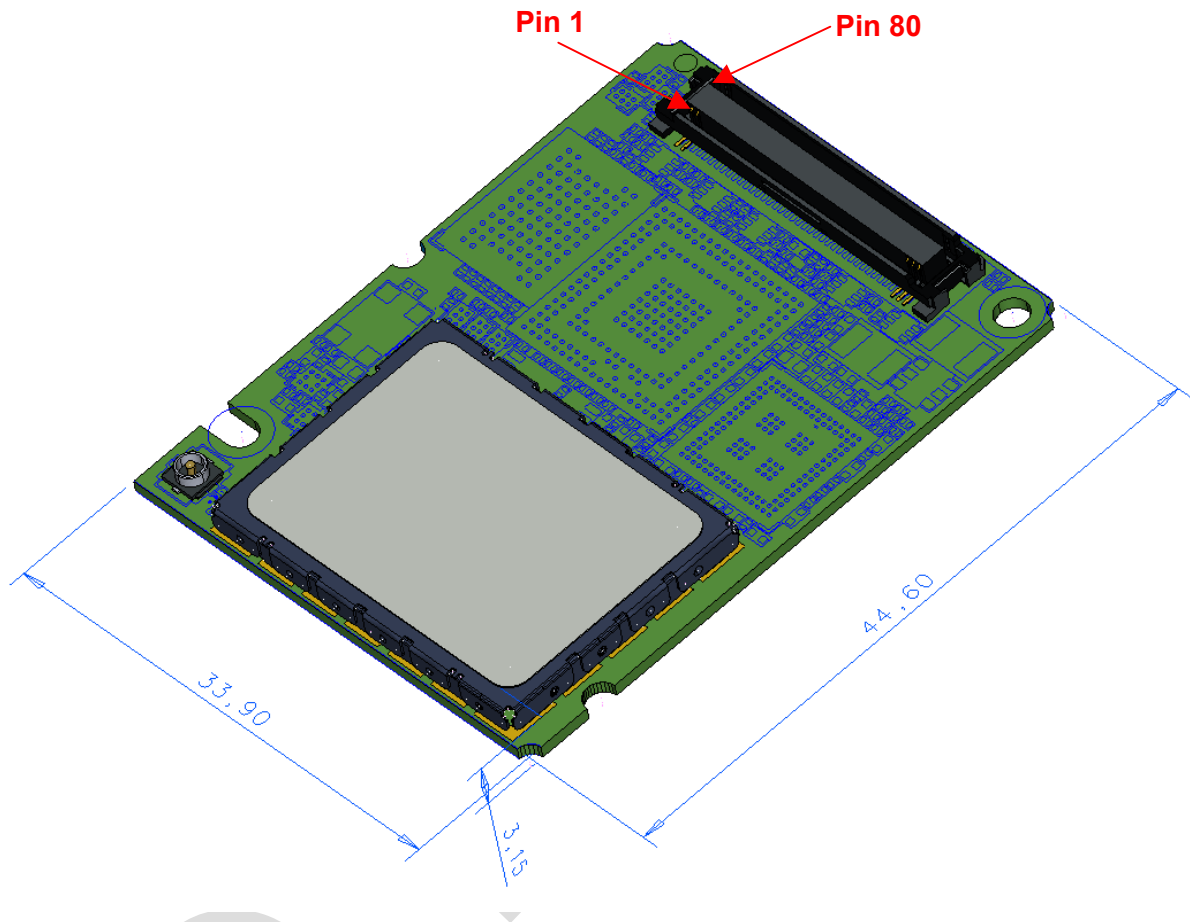
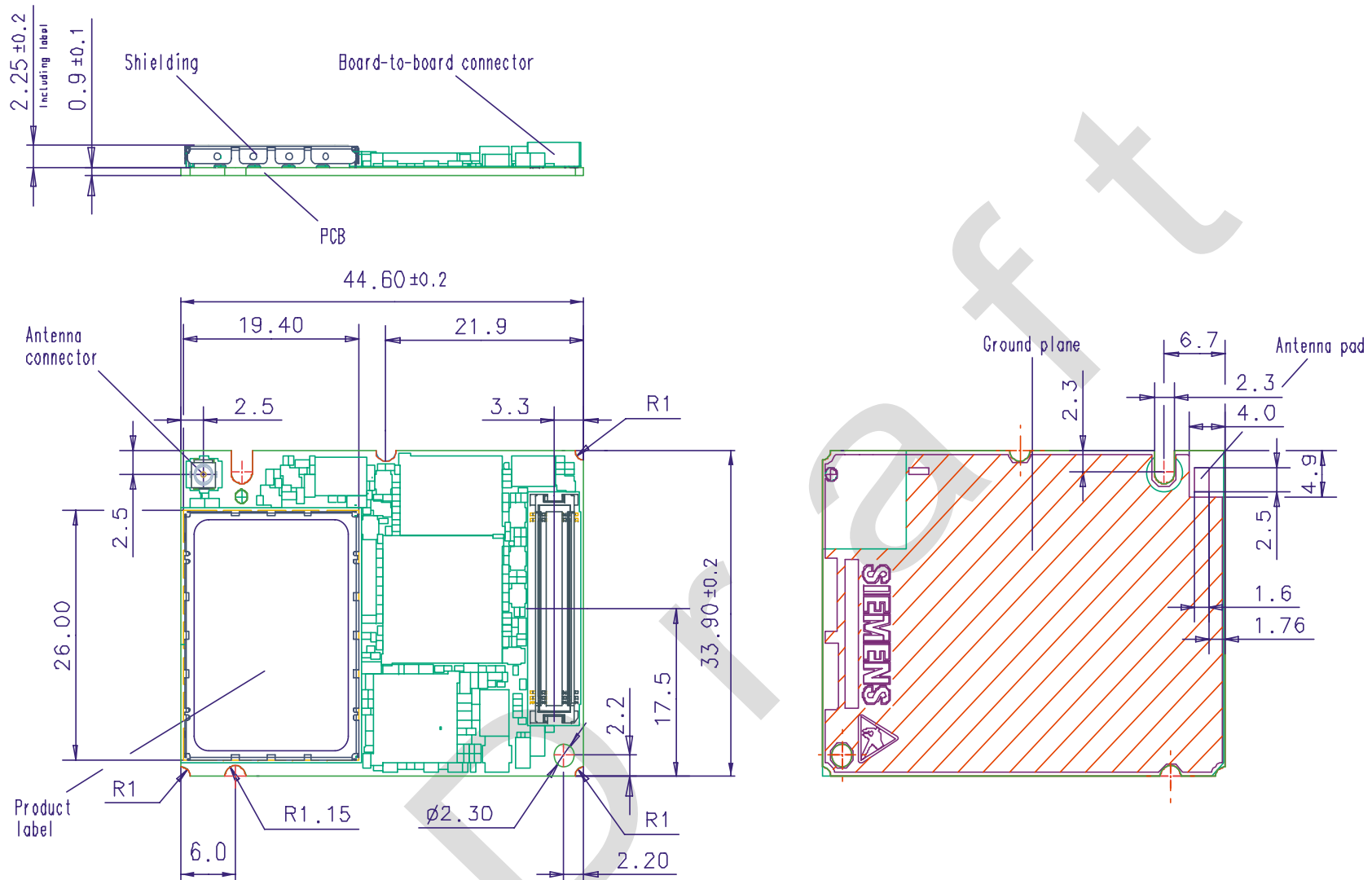

Figure 35: MC75 – top view



All dimensions in mm

Figure 36: Dimensions of MC75

## 6.2 Mounting MC75 to the Application Platform

There are many ways to properly install MC75 in the host device. An efficient approach is to mount the MC75 PCB to a frame, plate, rack or chassis.

Fasteners can be M2 screws plus suitable washers, circuit board spacers, or customized screws, clamps, or brackets. In addition, the board-to-board connection can also be utilized to achieve better support. To help you find appropriate spacers a list of selected screws and distance sleeves for 3mm stacking height can be found in Section 9.2.

When using the two small holes take care that the screws are inserted with the screw head on the bottom of the MC75 PCB. Screws for the large holes can be inserted from top or bottom.

For proper grounding it is strongly recommended to use large ground plane on the bottom of board in addition to the five GND pins of the board-to-board connector. The ground plane may also be used to attach cooling elements, e.g. a heat sink or thermally conductive tape.

To prevent mechanical damage, be careful not to force, bend or twist the module. Be sure it is positioned flat against the host device.

All the information you need to install an antenna is summarized in Chapter 4. Note that the antenna pad on the bottom of the MC75 PCB must not be influenced by any other PCBs, components or by the housing of the host device. It needs to be surrounded by a restricted space as described in Section 4.1.

### 6.3 Board-to-Board Application Connector

This section provides the specifications of the 80-pin board-to-board connector used to connect MC75 to the external application.

Connector mounted on the MC75 module:  
 Type: 52991-0808 SlimStack Receptacle  
 80 pins, 0.50mm pitch,  
 for stacking heights from 3.0 to 4.0mm,  
 see Figure 37 for details.

Supplier: Molex  
[www.molex.com](http://www.molex.com)

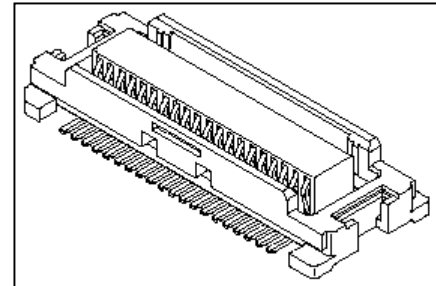
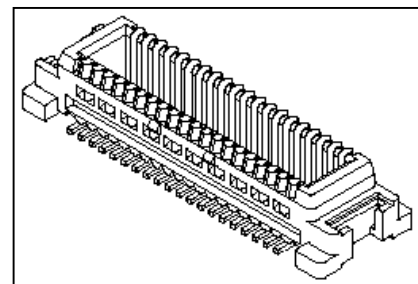

Table 19: Technical specifications of Molex board-to-board connector

Parameter	Specification (80-pin B2B connector)
<i>Electrical</i>	
Number of Contacts	80
Contact spacing	0.5mm (.020")
Voltage	50V
Rated current	0.5 A max per contact
Contact resistance	50mΩ max per contact
Insulation resistance	> 100 MΩ
Dielectric Withstanding Voltage	500 V AC (for 1 minute)
<i>Physical</i>	
Insulator material (housing)	White glass-filled LCP plastic, flammability UL 94V 0
Contact material	Plating: Gold over nickel
Insertion force 1 <sup>st</sup>	< 74.4 N
Insertion force 30 <sup>th</sup>	< 65.6 N
Withdrawal force 1 <sup>st</sup>	> 10.8 N
Maximum connection cycles	30 (@ 70mΩ max per contact)

Mating connector types for the customer's application offered by Molex:

- 53748-0808 SlimStack Plug, 3mm stacking height, see Figure 38 for details.
- 53916-0808 SlimStack Plug, 4mm stacking height



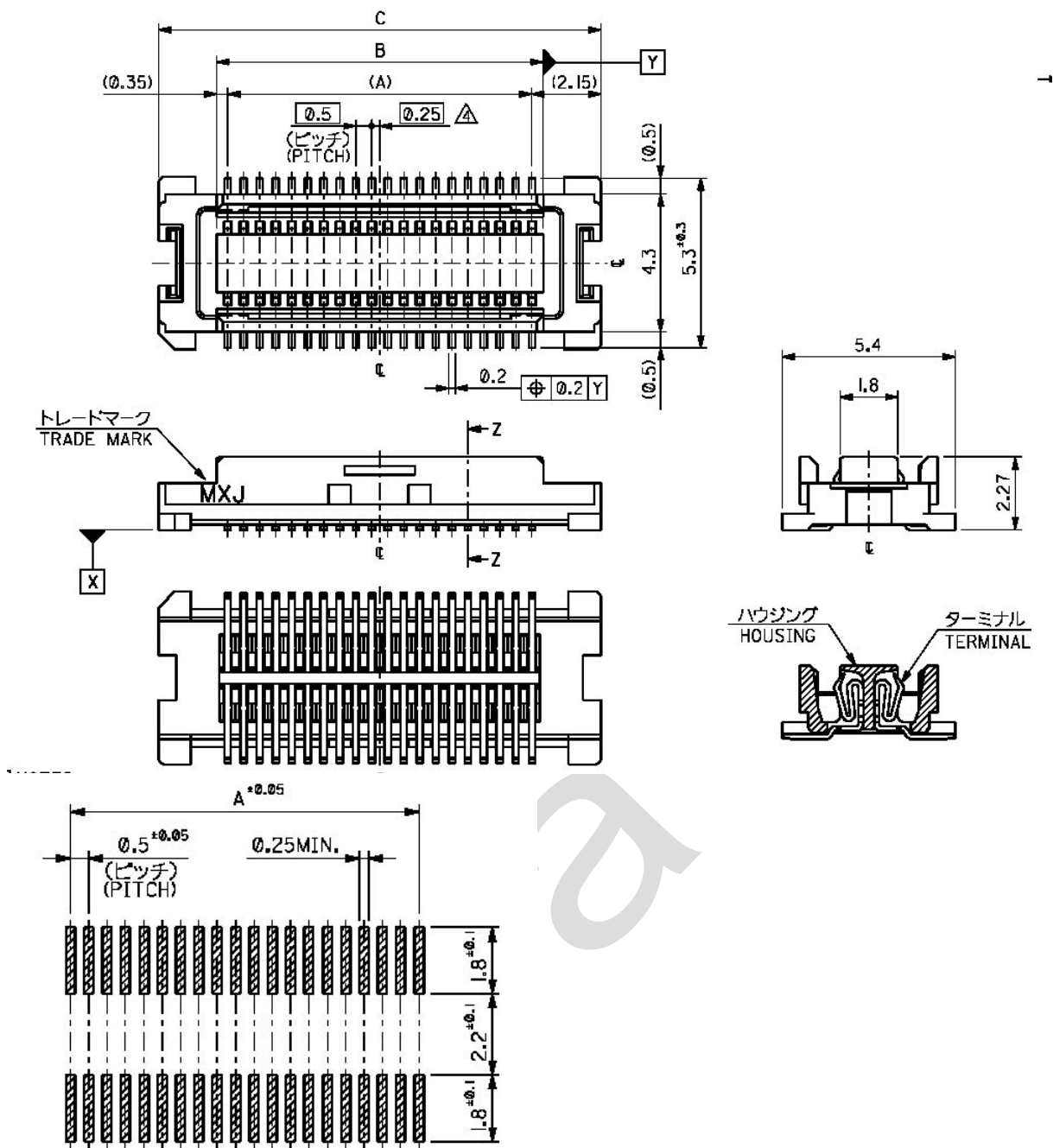





## 7 Sample Application

Figure 39 shows a typical example of how to integrate a MC75 module into the GSM part of a mobile application. Usage of the various host interfaces depends on the desired features of the application.

Audio interface 1 demonstrates the balanced connection of microphone and earpiece. This solution is particularly well suited for internal transducers. Audio interface 2 uses an unbalanced microphone and earpiece connection typically found in headset applications.

The charging circuit is optimized for the charging stages (trickle charging and software controlled charging) as well as the battery and charger specifications described in Section 3.4.

The PWR\_IND line is an open collector that needs an external pull-up resistor which connects to the voltage supply of the microcontroller VCC  $\mu$ C. Low state of the open collector pulls the PWR\_IND signal low and indicates that the MC75 module is active, high level notifies the Power-down mode.

If the module is in Power-down mode avoid current flowing from any other source into the module circuit, for example reverse current from high state external control lines. Therefore, the controlling application must be designed to prevent reverse or return flow. This is not necessary for the USB interface.

The SD memory card interface can be powered from an external supply or via the VEXT line of MC75. Figure 39 uses the VEXT line. The advantage of this solution is that when the module enters the Power-down mode, the SD memory card interface is shut down as well. If you prefer to connect an SD card to an external power supply, take care that the interface is shut down when the PWR\_IND signal goes high in Power-down mode. The same applies to the I<sup>2</sup>C interface.

The EMC measures are best practice recommendations. In fact, an adequate EMC strategy for an individual application is very much determined by the overall layout and, especially, the position of components. For example, mounting the internal acoustic transducers directly on the PCB eliminates the need to use the ferrite beads shown in the sample schematic. However, when connecting cables to the module's interfaces it is strongly recommended to add appropriate ferrite beads for reducing RF radiation.

### Disclaimer

No warranty, either stated or implied, is provided on the sample schematic diagram shown in Figure 39 and the information detailed in this section. As functionality and compliance with national regulations depend to a great amount on the used electronic components and the individual application layout manufacturers are required to ensure adequate design and operating safeguards for their products using MC75 modules.

# MC75 Application (Draft) \*)

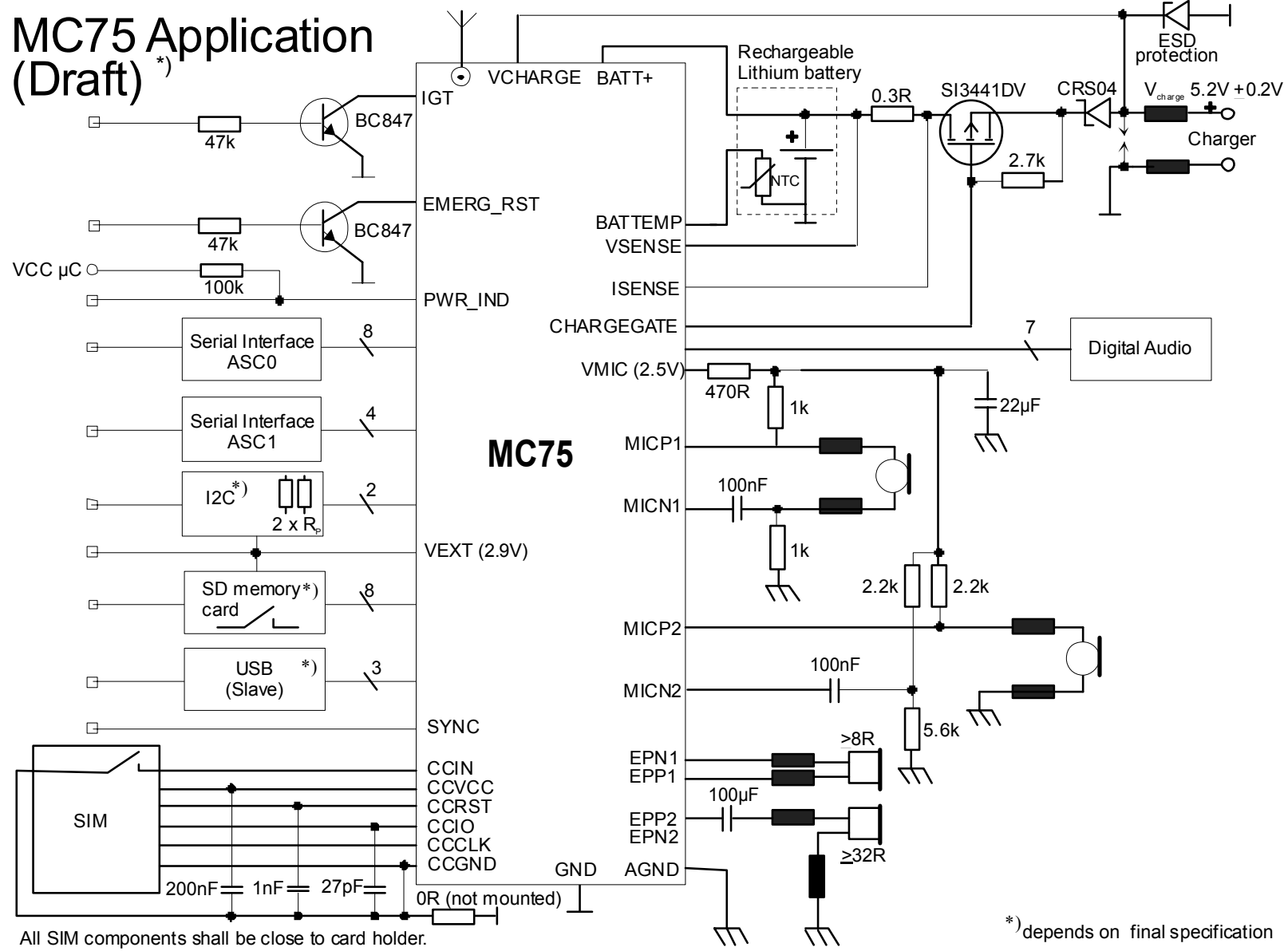

Figure 39: MC75 sample application (draft)

## 8 Reference Approval

### 8.1 Reference Equipment for Type Approval

The Siemens reference setup submitted to type approve MC75 consists of the following components:

- Siemens MC75 cellular engine
- Development Support Box DSB75
- SIM card reader integrated on DSB75
- U.FL-R-SMT antenna connector and U.FL-LP antenna cable
- Handset type Votronic HH-SI-30.3/V1.1/0
- Li-Ion battery
- PC as MMI

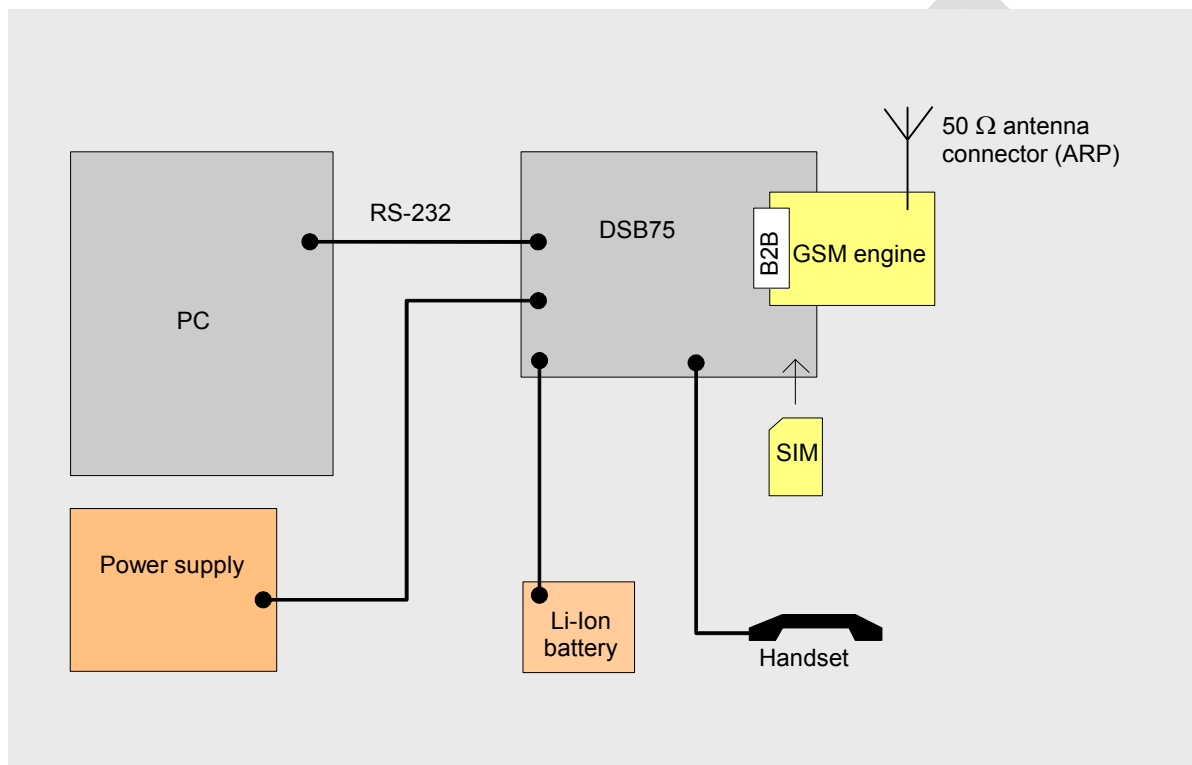

Figure 40: Reference equipment for Type Approval

## 8.2 Compliance with FCC Rules and Regulations

The FCC Equipment Authorization Certification for the MC75 reference application described in Section 8.1 is listed under the

*FCC identifier QIPMC75  
IC: 267W-MC75  
granted to Siemens AG.*

The MC75 reference application registered under the above identifier is certified to be in accordance with the following Rules and Regulations of the Federal Communications Commission (FCC).

Power listed is ERP for Part 22 and EIRP for Part 24

“This device contains GSM, GPRS Class12 and EGPRS Class 10 functions in the 900 and 1800MHz Band which are not operational in U.S. Territories.

This device is to be used only for mobile and fixed applications. The antenna(s) used for this transmitter must be installed to provide a separation distance of at least 20cm from all persons and must not be co-located or operating in conjunction with any other antenna or transmitter. Users and installers must be provided with antenna installation instructions and transmitter operating conditions for satisfying RF exposure compliance. Antennas used for this OEM module must not exceed 8.4dBi gain (GSM 1900) and 2.9dBi (GSM 850) for mobile and fixed operating configurations. This device is approved as a module to be installed in other devices.

The FCC label of the module must be visible from the outside. If not, the host device is required to bear a second label stating, “Contains FCC ID QIPMC75”.

IMPORTANT: Manufacturers of mobile or fixed devices incorporating MC75 modules are advised to

- clarify any regulatory questions,
- have their completed product tested,
- have product approved for FCC compliance, and
- include instructions according to above mentioned RF exposure statements in end product user manual.

Please note that changes or modifications not expressly approved by the party responsible for compliance could void the user’s authority to operate the equipment.

## 9 Appendix

### 9.1 List of Parts and Accessories

Table 20: List of parts and accessories

Description	Supplier	Ordering information
MC75	Siemens	Siemens ordering number: L36880-N8810-N100
Siemens Car Kit Portable	Siemens	Siemens ordering number: L36880-N3015-A117
DSB75 Support Box	Siemens	Siemens ordering number:
Votronic Handset	VOTRONIC	Votronic HH-SI-30.3/V1.1/0 VOTRONIC Entwicklungs- und Produktionsgesellschaft für elektronische Geräte mbH Saarbrücker Str. 8 66386 St. Ingbert Germany Phone: +49-(0)6 89 4 / 92 55-0 Fax: +49-(0)6 89 4 / 92 55-88 e-mail: <a href="mailto:contact@votronic.com">contact@votronic.com</a>
SIM card holder incl. push button ejector and slide-in tray	Molex	Ordering numbers: 91228 91236 Sales contacts are listed in Table 21.
Board-to-board connector	Molex	Sales contacts are listed in Table 21.
U.FL-R-SMT antenna connector	Hirose	See Section 4.3 for details on U.FL-R-SMT connector, mating plugs and cables. Sales contacts are listed in Table 22.

Table 21: Molex sales contacts (subject to change)

<p>Molex For further information please click: <a href="http://www.molex.com/">http://www.molex.com/</a></p>	<p>Molex Deutschland GmbH Felix-Wankel-Str. 11 4078 Heilbronn-Biberach Germany Phone: +49-7066-9555 0 Fax: +49-7066-9555 29 Email: <a href="mailto:mxgermany@molex.com">mxgermany@molex.com</a></p>	<p>American Headquarters Lisle, Illinois 60532 U.S.A. Phone: +1-800-78MOLEX Fax: +1-630-969-1352</p>
<p>Molex China Distributors Beijing, Room 1319, Tower B, COFCO Plaza No. 8, Jian Guo Men Nei Street, 100005 Beijing P.R. China Phone: +86-10-6526-9628 Phone: +86-10-6526-9728 Phone: +86-10-6526-9731 Fax: +86-10-6526-9730</p>	<p>Molex Singapore Pte. Ltd. Jurong, Singapore Phone: +65-268-6868 Fax: +65-265-6044</p>	<p>Molex Japan Co. Ltd. Yamato, Kanagawa, Japan Phone: +81-462-65-2324 Fax: +81-462-65-2366</p>

Table 22: Hirose sales contacts (subject to change)

<p>Hirose Ltd. For further information please click: <a href="http://www.hirose.com">http://www.hirose.com</a></p>	<p>Hirose Electric (U.S.A.) Inc 2688 Westhills Court Simi Valley, CA 93065 U.S.A. Phone: +1-805-522-7958 Fax: +1-805-522-3217</p>	<p>Hirose Electric GmbH Zeppelinstrasse 42 73760 Ostfildern Kemnat 4 Germany Phone: +49-711-4560-021 Fax +49-711-4560-729 E-mail <a href="mailto:info@hirose.de">info@hirose.de</a></p>
<p>Hirose Electric UK, Ltd Crownhill Business Centre 22 Vincent Avenue, Crownhill Milton Keynes, MK8 OAB Great Britain Phone:+44-1908-305400 Fax: +44-1908-305401</p>	<p>Hirose Electric Co., Ltd. 5-23, Osaki 5 Chome, Shinagawa-Ku Tokyo 141 Japan Phone: +81-03-3491-9741 Fax: +81-03-3493-2933</p>	<p>Hirose Electric Co., Ltd. European Branche First class Building 4F Beechavenue 46 1119PV Schiphol-Rijk Netherlands Phone: +31-20-6557-460 Fax: +31-20-6557-469</p>

## 9.2 Fasteners and Fixings for Electronic Equipment

This section provides a list of suppliers and manufacturers offering fasteners and fixings for electronic equipment and PCB mounting. The content of this section is designed to offer basic guidance to various mounting solutions with no warranty on the accuracy and sufficiency of the information supplied. Please note that the list remains preliminary although it is going to be updated in later versions of this document.

### 9.2.1 Fasteners from German Supplier ETTINGER GmbH

Sales contact: ETTINGER GmbH  
<http://www.ettinger.de/main.cfm>  
 Phone: +4981 04 66 23 – 0  
 Fax: +4981 04 66 23 – 0

The following tables contain only article numbers and basic parameters of the listed components. For further detail and ordering information please contact Ettinger GmbH.

Please note that some of the listed screws, spacers and nuts are delivered with the DSB75 Support Board. See comments below.

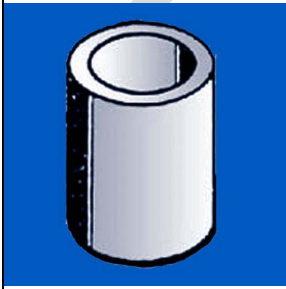
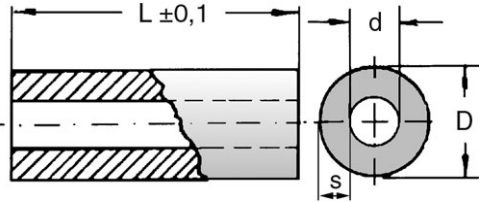
Article number: 05.71.038	<b>Spacer - Aluminum / Wall thickness = 0.8mm</b>
Length	3.0 mm
Material	AlMgSi-0,5
For internal diameter	M2=2.0-2.3
Internal diameter	d = 2.4 mm
External diameter	4.0 mm
Vogt AG No.	x40030080.10
	

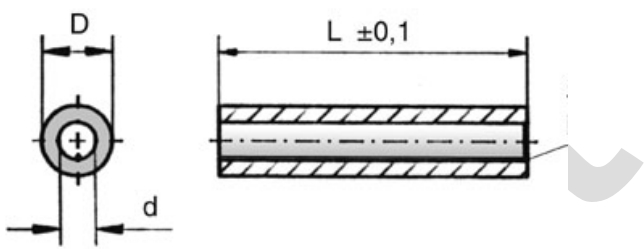

Article number: 07.51.403	<b>Insulating Spacer for M2 Self-gripping <sup>*)</sup></b>
Length	3.0 mm
Material	Polyamide 6.6
Surface	Black
Internal diameter	2.2 mm
External diameter	4.0 mm
Flammability rating	UL94-HB
	

<sup>\*)</sup> 2 spacers are delivered with DSB75 Support Board

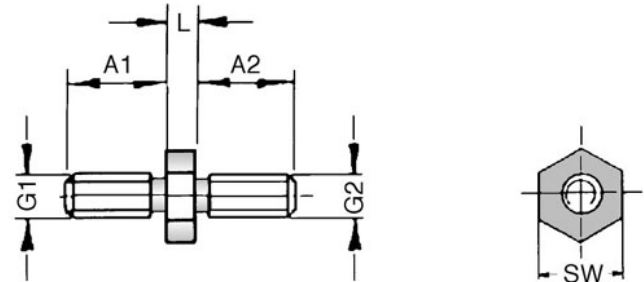
Article number: 05.11.209	<b>Threaded Stud M2.5 - M2 Type E / External thread at both ends</b>
Length	3.0 mm
Material	Stainless steel X12CrMoS17
Thread 1 / Length	M2.5 / 6.0 mm
Thread 2 / Length	M2 / 8.0 mm
Width across flats	5
Recess	yes
Type	External / External
	

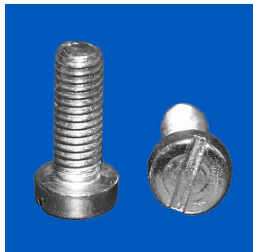
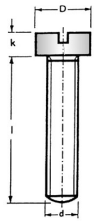
Article number: 01.14.131	<b>Screw M2 <sup>*)</sup></b> <b>DIN 84 - ISO 1207</b>
Length	8.0 mm
Material	Steel 4.8
Surface	Zincd A2K
Thread	M2
Head diameter	D = 3.8 mm
Head height	1.30 mm
Type	Slotted cheese head screw
	

\*) 2 screws are delivered with DSB75 Support Board

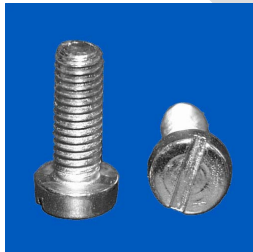
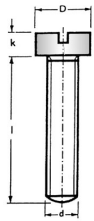
Article number: 01.14.141	<b>Screw M2</b> <b>DIN 84 - ISO 1207</b>
Length	10.0 mm
Material	Steel 4.8
Surface	Zincd A2K
Thread	M2
Head diameter	D = 3.8 mm
Head height	1.30 mm
Type	Slotted cheese head screw
	

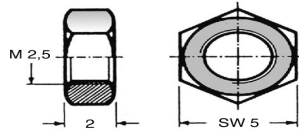
Article number: 02.10.011	<b>Hexagon Nut <sup>*)</sup></b> <b>DIN 934 - ISO 4032</b>
Material	Steel 4.8
Surface	Zincd A2K
Thread	M2
Wrench size / Ø	4
Thickness / L	1.6 mm
Type	Nut DIN/UNC, DIN934
	

<sup>\*)</sup> 2 nuts are delivered with DSB75 Support Board

### 9.3 Data Sheets of Recommended Batteries

The following two data sheets have been provided by VARTA Microbattery GmbH.

Click here for sales contacts and further information: <http://www.varta-microbattery.com>

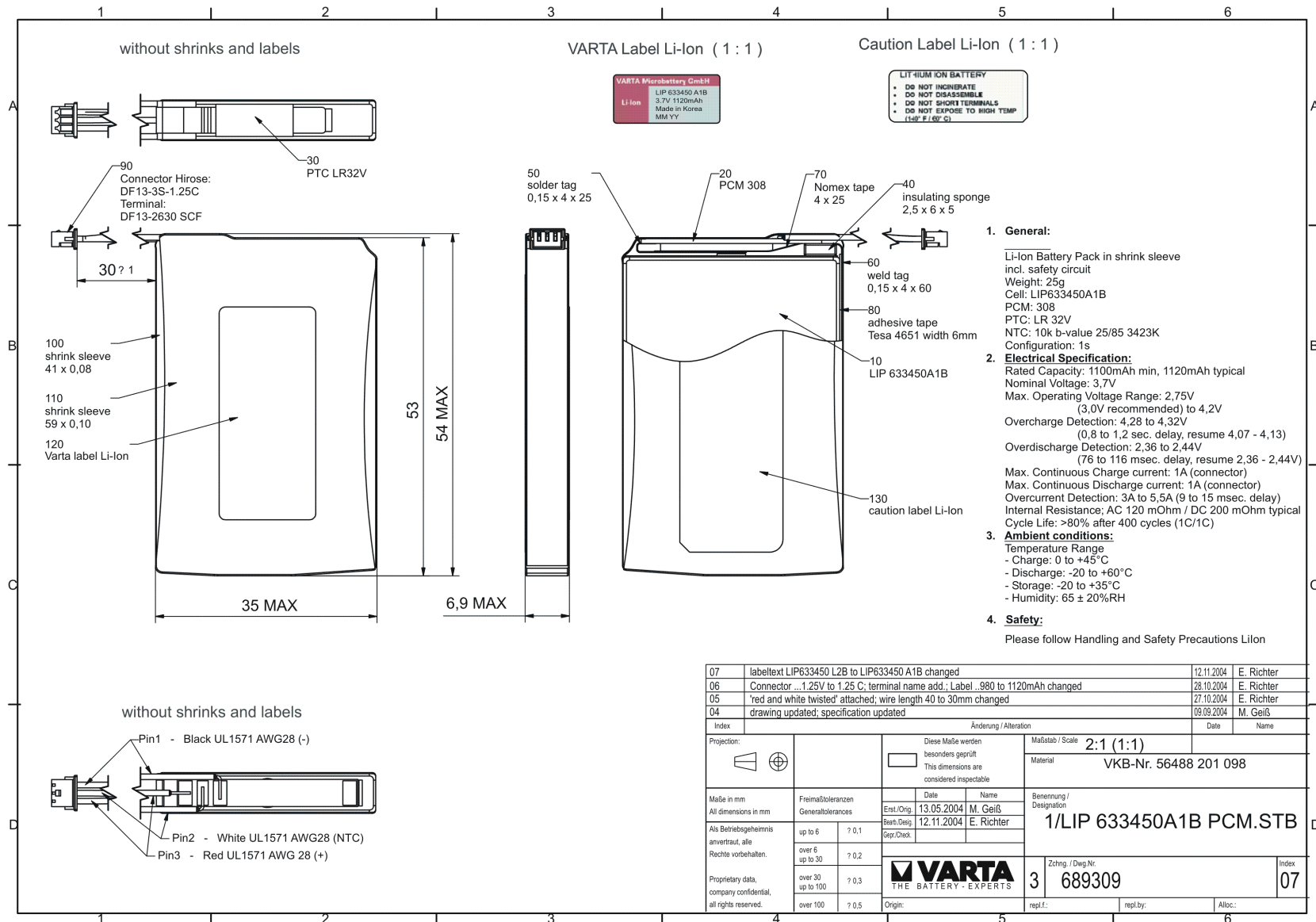

Figure 41: Lithium Ion battery from VARTA

