



**DFS portion of
FCC CFR47 PART 15 SUBPART E
INDUSTRY CANADA RSS-210 ISSUE 7**

CERTIFICATION TEST REPORT

FOR

INTEGRATED MEASUREMENT INTERFACE BOX

MODEL NUMBER: IMIB

**FCC ID: LYHIMIB0001
IC: 267AA-IMIB001**

REPORT NUMBER: 08U12233-1

ISSUE DATE: NOVEMBER 21, 2008

Prepared for
**SIEMENS AG
76187 KARLSRUHE
GERMANY**

Prepared by
**COMPLIANCE CERTIFICATION SERVICES
47173 BENICIA STREET
FREMONT, CA 94538, U.S.A.
TEL: (510) 771-1000
FAX: (510) 661-0888**



NVLAP LAB CODE 200065-0

Revision History

<u>Rev.</u>	<u>Issue Date</u>	<u>Revisions</u>	<u>Revised By</u>
--	11/21/2008	Initial Issue	M. Heckrotte

TABLE OF CONTENTS

1. ATTESTATION OF TEST RESULTS	4
2. TEST METHODOLOGY	5
3. FACILITIES AND ACCREDITATION	5
4. CALIBRATION AND UNCERTAINTY	5
4.1. <i>MEASURING INSTRUMENT CALIBRATION</i>	5
4.2. <i>MEASUREMENT UNCERTAINTY</i>	5
5. DYNAMIC FREQUENCY SELECTION	6
5.1. <i>OVERVIEW</i>	6
5.1.1. <i>LIMITS</i>	6
5.1.2. <i>TEST AND MEASUREMENT SYSTEM</i>	10
5.1.3. <i>DESCRIPTION OF EUT</i>	14
5.2. <i>RESULTS FOR 20 MHz BANDWIDTH</i>	15
5.2.1. <i>TEST CHANNEL AND METHOD</i>	15
5.2.2. <i>PLOTS OF RADAR WAVEFORM, AND WLAN TRAFFIC</i>	15
5.2.3. <i>CHANNEL MOVE TIME AND CHANNEL CLOSING TRANSMISSION TIME</i>	17
5.2.4. <i>NON-OCCUPANCY PERIOD</i>	22
5.3. <i>RESULTS FOR 40 MHz BANDWIDTH</i>	23
5.3.1. <i>TEST CHANNEL AND METHOD</i>	23
5.3.2. <i>PLOTS OF RADAR WAVEFORM, AND WLAN TRAFFIC</i>	23
5.3.3. <i>CHANNEL MOVE TIME AND CHANNEL CLOSING TRANSMISSION TIME</i>	25
5.3.4. <i>NON-OCCUPANCY PERIOD</i>	30
6. SETUP PHOTOS	31

1. ATTESTATION OF TEST RESULTS

COMPANY NAME: SIEMENS AG
76187 KARLSRUHE
GERMANY

EUT DESCRIPTION: INTEGRATED MEASUREMENT INTERFACE BOX

MODEL: IMIB

SERIAL NUMBER: PT0095

DATE TESTED: NOVEMBER 18, 2008

APPLICABLE STANDARDS	
STANDARD	TEST RESULTS
DFS portion of CFR 47 Part 15 Subpart E	Pass
DFS portion of INDUSTRY CANADA RSS-210 Issue 7 Annex 9	Pass

Compliance Certification Services, Inc. (CCS) tested the above equipment in accordance with the requirements set forth in the above standards. All indications of Pass/Fail in this report are opinions expressed by CCS based on interpretations and/or observations of test results. The test results show that the equipment tested is capable of demonstrating compliance with the requirements as documented in this report.

Note: The results documented in this report apply only to the tested sample, under the conditions and modes of operation as described herein. This document may not be altered or revised in any way unless done so by CCS and all revisions are duly noted in the revisions section. Any alteration of this document not carried out by CCS will constitute fraud and shall nullify the document. No part of this report may be used to claim product certification, approval, or endorsement by NVLAP, NIST, or any government agency.

Approved & Released For CCS By:

Tested By:



MICHAEL HECKROTTE
DIRECTOR OF ENGINEERING
COMPLIANCE CERTIFICATION SERVICES

MONICA HARRISON
EMC ENGINEER
COMPLIANCE CERTIFICATION SERVICES

2. TEST METHODOLOGY

The tests documented in this report were performed in accordance with FCC 06-96 and the DFS portion of FCC Part 15 Subpart E and RSS-210 Issue 7.

3. FACILITIES AND ACCREDITATION

The test sites and measurement facilities used to collect data are located at 47173 Benicia Street, Fremont, California, USA.

CCS is accredited by NVLAP, Laboratory Code 200065-0. The full scope of accreditation can be viewed at <http://www.ccsemc.com>.

4. CALIBRATION AND UNCERTAINTY

4.1. MEASURING INSTRUMENT CALIBRATION

The measuring equipment utilized to perform the tests documented in this report has been calibrated in accordance with the manufacturer's recommendations, and is traceable to recognized national standards.

4.2. MEASUREMENT UNCERTAINTY

Where relevant, the following measurement uncertainty levels have been estimated for tests performed on the apparatus:

PARAMETER	UNCERTAINTY
Power Line Conducted Emission	+/- 2.3 dB
Radiated Emission	+/- 3.4 dB

Uncertainty figures are valid to a confidence level of 95%.

5. DYNAMIC FREQUENCY SELECTION

5.1. OVERVIEW

5.1.1. LIMITS

INDUSTRY CANADA

IC RSS-210 is closely harmonized with FCC Part 15 DFS rules. The deviations are as follows:

RSS-210 Issue 7 A9.4 (b) (ii) **Channel Availability Check Time:** ...

Additional requirements for the band 5600-5650 MHz: Until further notice, devices subject to this Section shall not be capable of transmitting in the band 5600-5650 MHz, so that Environment Canada weather radars operating in this band are protected.

RSS-210 Issue 7 A9.4 (b) (iv) **Channel closing time:** the maximum channel closing time is 260 ms.

FCC

§15.407 (h) and FCC 06-96 APPENDIX "COMPLIANCE MEASUREMENT PROCEDURES FOR UNLICENSED-NATIONAL INFORMATION INFRASTRUCTURE DEVCIES OPERATING IN THE 5250-5350 MHz AND 5470-5725 MHz BANDS INCORPORATING DYNAMIC FREQUENCY SELECTION".

Table 1: Applicability of DFS requirements prior to use of a channel

Requirement	Operational Mode		
	Master	Client (without radar detection)	Client (with radar detection)
<i>Non-Occupancy Period</i>	Yes	Not required	Yes
<i>DFS Detection Threshold</i>	Yes	Not required	Yes
<i>Channel Availability Check Time</i>	Yes	Not required	Not required
<i>Uniform Spreading</i>	Yes	Not required	Not required

Table 2: Applicability of DFS requirements during normal operation

Requirement	Operational Mode		
	Master	Client (without DFS)	Client (with DFS)
<i>DFS Detection Threshold</i>	Yes	Not required	Yes
<i>Channel Closing Transmission Time</i>	Yes	Yes	Yes
<i>Channel Move Time</i>	Yes	Yes	Yes

Table 3: Interference Threshold values, Master or Client incorporating In-Service Monitoring

Maximum Transmit Power	Value (see note)
≥ 200 milliwatt	-64 dBm
< 200 milliwatt	-62 dBm
Note 1: This is the level at the input of the receiver assuming a 0 dBi receive antenna Note 2: Throughout these test procedures an additional 1 dB has been added to the amplitude of the test transmission waveforms to account for variations in measurement equipment. This will ensure that the test signal is at or above the detection threshold level to trigger a DFS response.	

Table 4: DFS Response requirement values

Parameter	Value
<i>Non-occupancy period</i>	30 minutes
<i>Channel Availability Check Time</i>	60 seconds
<i>Channel Move Time</i>	10 seconds
<i>Channel Closing Transmission Time</i>	200 milliseconds + approx. 60 milliseconds over remaining 10 second period
The instant that the <i>Channel Move Time</i> and the <i>Channel Closing Transmission Time</i> begins is as follows: <ul style="list-style-type: none"> • For the Short pulse radar Test Signals this instant is the end of the <i>Burst</i>. • For the Frequency Hopping radar Test Signal, this instant is the end of the last radar burst generated. • For the Long Pulse radar Test Signal this instant is the end of the 12 second period defining the radar transmission. The Channel Closing Transmission Time is comprised of 200 milliseconds starting at the beginning of the Channel Move Time plus any additional intermittent control signals required to facilitate channel changes (an aggregate of approximately 60 milliseconds) during the remainder of the 10 second period. The aggregate duration of control signals will not count quiet periods in between transmissions.	

Table 5 – Short Pulse Radar Test Waveforms

Radar Type	Pulse Width (Microseconds)	PRI (Microseconds)	Pulses	Minimum Percentage of Successful Detection	Minimum Trials
1	1	1428	18	60%	30
2	1-5	150-230	23-29	60%	30
3	6-10	200-500	16-18	60%	30
4	11-20	200-500	12-16	60%	30
Aggregate (Radar Types 1-4)				80%	120

Table 6 – Long Pulse Radar Test Signal

Radar Waveform	Bursts	Pulses per Burst	Pulse Width (µsec)	Chirp Width (MHz)	PRI (µsec)	Minimum Percentage of Successful Detection	Minimum Trials
5	8-20	1-3	50-100	5-20	1000-2000	80%	30

Table 7 – Frequency Hopping Radar Test Signal

Radar Waveform	Pulse Width (µsec)	PRI (µsec)	Burst Length (ms)	Pulses per Hop	Hopping Rate (kHz)	Minimum Percentage of Successful Detection	Minimum Trials
6	1	333	300	9	.333	70%	30

5.1.2. TEST AND MEASUREMENT SYSTEM

CONDUCTED METHOD SYSTEM BLOCK DIAGRAM

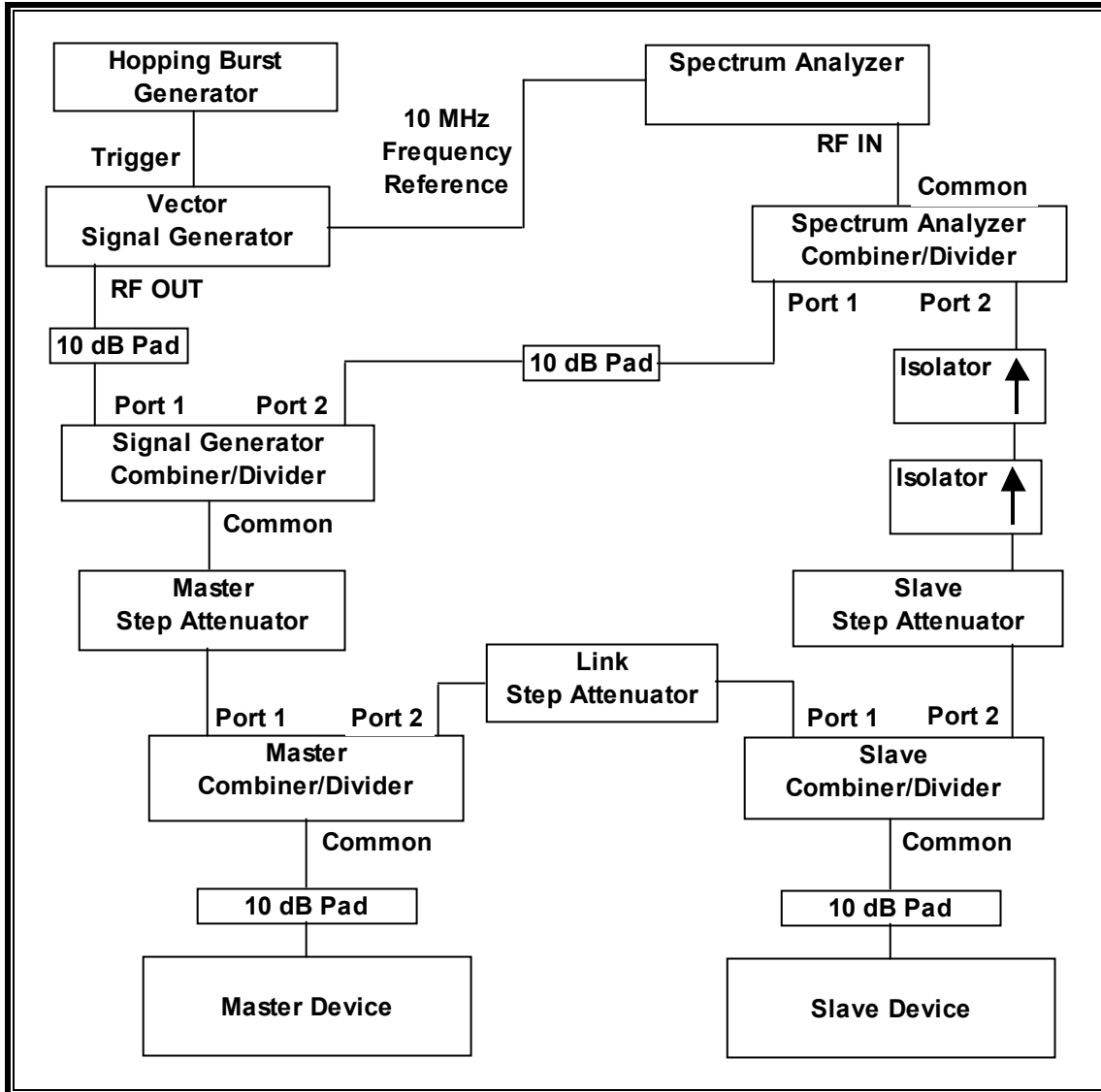

SYSTEM OVERVIEW

The short pulse and long pulse signal generating system utilizes the NTIA software. The Vector Signal Generator has been validated by the NTIA. The hopping signal generating system utilizes the CCS simulated hopping method and system, which has been validated by the DoD, FCC and NTIA. The software selects waveform parameters from within the bounds of the signal type on a random basis using uniform distribution.

The short pulse types 2, 3 and 4, and the long pulse type 5 parameters are randomized at run-time.

The hopping type 6 pulse parameters are fixed while the hopping sequence is based on the August 2005 NTIA Hopping Frequency List. The initial starting point randomized at run-time and each subsequent starting point is incremented by 475. Each frequency in the 100-length segment is compared to the boundaries of the EUT Detection Bandwidth and the software creates a hopping burst pattern in accordance with Section 7.4.1.3 Method #2 Simulated Frequency Hopping Radar Waveform Generating Subsystem of FCC 06-96 APPENDIX. The frequency of the signal generator is incremented in 1 MHz steps from F_L to F_H for each successive trial. This incremental sequence is repeated as required to generate a minimum of 30 total trials and to maintain a uniform frequency distribution over the entire Detection Bandwidth.

The signal monitoring equipment consists of a spectrum analyzer set to display 8001 bins on the horizontal axis. The time-domain resolution is 2 msec / bin with a 16 second sweep time, meeting the 10 second short pulse reporting criteria. The aggregate ON time is calculated by multiplying the number of bins above a threshold during a particular observation period by the dwell time per bin, with the analyzer set to peak detection and max hold.

Should multiple RF ports be utilized for the Master and/or Slave devices (for example, for diversity or MIMO implementations), additional combiner/dividers are inserted between the Master Combiner/Divider and the pad connected to the Master Device (and/or between the Slave Combiner/Divider and the pad connected to the Slave Device). Additional pads are utilized such that there is one pad at each RF port on each EUT.

SYSTEM CALIBRATION

A 50 ohm load is connected in place of the spectrum analyzer, and the spectrum analyzer is connected in place of the master device and the signal generator is set to CW mode. The amplitude of the signal generator is adjusted to yield a level of -64 dBm as measured on the spectrum analyzer.

Without changing any of the instrument settings, the spectrum analyzer is reconnected to the Common port of the Spectrum Analyzer Combiner/Divider. Measure the amplitude and calculate the difference from -64 dBm. Adjust the Reference Level Offset of the spectrum analyzer to this difference.

The spectrum analyzer displays the level of the signal generator as received at the antenna ports of the Master Device. The interference detection threshold may be varied from the calibrated value of -64 dBm and the spectrum analyzer will still indicate the level as received by the Master Device.

Set the signal generator to produce a radar waveform, trigger a burst manually and measure the level on the spectrum analyzer. Readjust the amplitude of the signal generator as required so that the peak level of the waveform is at a displayed level equal to the required or desired interference detection threshold. Separate signal generator amplitude settings are determined as required for each radar type.

ADJUSTMENT OF DISPLAYED TRAFFIC LEVEL

Establish a link between the Master and Slave, adjusting the Link Step Attenuator as needed to provide a suitable received level at the Master and Slave devices. Stream the video test file to generate WLAN traffic. Confirm that the WLAN traffic level, as displayed on the spectrum analyzer, is at lower amplitude than the radar detection threshold. For Master Device testing confirm that the displayed traffic does not include Slave Device traffic. For Slave Device testing confirm that the displayed traffic does not include Master Device traffic.

If a different setting of the Master Step Attenuator is required to meet the above conditions, perform a new System Calibration for the new Master Step Attenuator setting.

TEST AND MEASUREMENT EQUIPMENT

The following test and measurement equipment was utilized for the DFS tests documented in this report:

TEST EQUIPMENT LIST				
Description	Manufacturer	Model	Serial Number	Cal Due
MXA Signal Analyzer 26.5GHz	Agilent / HP	N9020A	US48350984	10/23/2009
PSG Signal Generator 40GHz	Agilent / HP	E8257D	MY48050612351-1	10/29/2009
Arbitrary Waveform Generator	Agilent / HP	33220A	C01146	5/5/2009

CONDUCTED METHOD EUT TEST SETUP

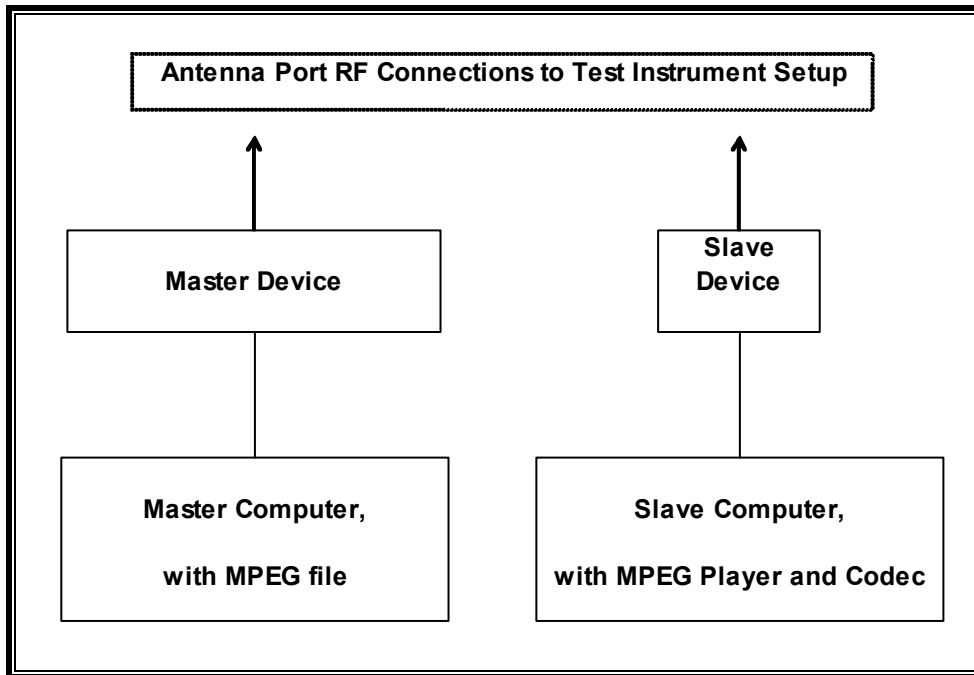

The EUT (Slave Device) does not have a display. All of the DFS software and driver software documented below in “Description of EUT” resides in the EUT. The Slave computer provides the streaming video player software and display capabilities for test purposes.

The video file is streamed from the Master computer to the Slave computer via the ethernet connection between the Master computer and the AP, the wireless link between the AP and the EUT, and the ethernet connection between the EUT and the Slave computer.

SUPPORT EQUIPMENT

The following test and measurement equipment was utilized for the DFS tests documented in this report:

PERIPHERAL SUPPORT EQUIPMENT LIST				
Description	Manufacturer	Model	Serial Number	FCC ID
IMIB AC Adapter	Fairway	VAN90A-195A-0A	SIEMENS A5E01212097	DoC
Master Laptop	Dell	Latitude D620	C01092	DoC
AC Adapter	Dell	LA65NS0-00	CN0DF263716156AU1019	DoC
Slave Laptop	Compaq	Presario 3000	CNU327025L	DoC
AC Adapter	Compaq	PPP012L	565BC0ALLOJ1BE	DoC
Access Point	Cisco	AP1252AG-A-K9	FTXF120690N2	LDK102061
AC Adapter	Delta	EADP-45BBB	DTH112490BD	DoC

5.1.3. DESCRIPTION OF EUT

The EUT is an Integrated Measurement Interface Device. It contains an Intel 4965AGN WLAN radio card that provides DFS functions. It operates over the 5250-5350 MHz range.

The EUT is a Slave Device without radar detection.

The highest power level within these bands is 21.4 dBm EIRP.

The antenna utilized with the EUT has a gain of 2 dBi.

Three identical integral antennas are utilized to meet MIMO and diversity operational requirements.

The EUT uses two Tx/Rx chains and one Rx only chain, each connected to a 50-ohm coaxial antenna port. All antenna ports are connected to the test system via a power divider to perform conducted tests.

WLAN traffic is generated by streaming the video file TestFile.mp2 "6 ½ Magic Hours" from the Master to the Slave in full motion video mode using the media player with the V2.61 Codec package.

TPC is not required since the maximum EIRP is less than 500 mW (27 dBm).

The EUT utilizes the 802.11a/n architecture. Two nominal channel bandwidths, 20 MHz and 40 MHz, are implemented.

The driver installed in the EUT is Intel V12.1.0.14.

The software installed in the EUT is Intel WiFi software version 12.1.1.0.

OVERVIEW OF MASTER DEVICE WITH RESPECT TO §15.407 (h) REQUIREMENTS

The Master Device is a Cisco Access Point, FCC ID: LDK102061. The DFS software installed in the Master Device is revision 6.00.1. The minimum antenna gain for the Master Device is 3.5 dBi.

The rated output power of the Master unit is > 23dBm (EIRP). Therefore the required interference threshold level is -64 dBm. After correction for antenna gain and procedural adjustments, the required conducted threshold at the antenna port is $-64 + 2 + 1 = -61$ dBm.

The calibrated conducted DFS Detection Threshold level is set to -64 dBm. The tested level is lower than the required level hence it provides margin to the limit.

5.2. RESULTS FOR 20 MHz BANDWIDTH

5.2.1. TEST CHANNEL AND METHOD

All tests were performed at a channel center frequency of 5320 MHz. Measurements were performed using conducted test methods.

5.2.2. PLOTS OF RADAR WAVEFORM, AND WLAN TRAFFIC

PLOTS OF RADAR WAVEFORMS

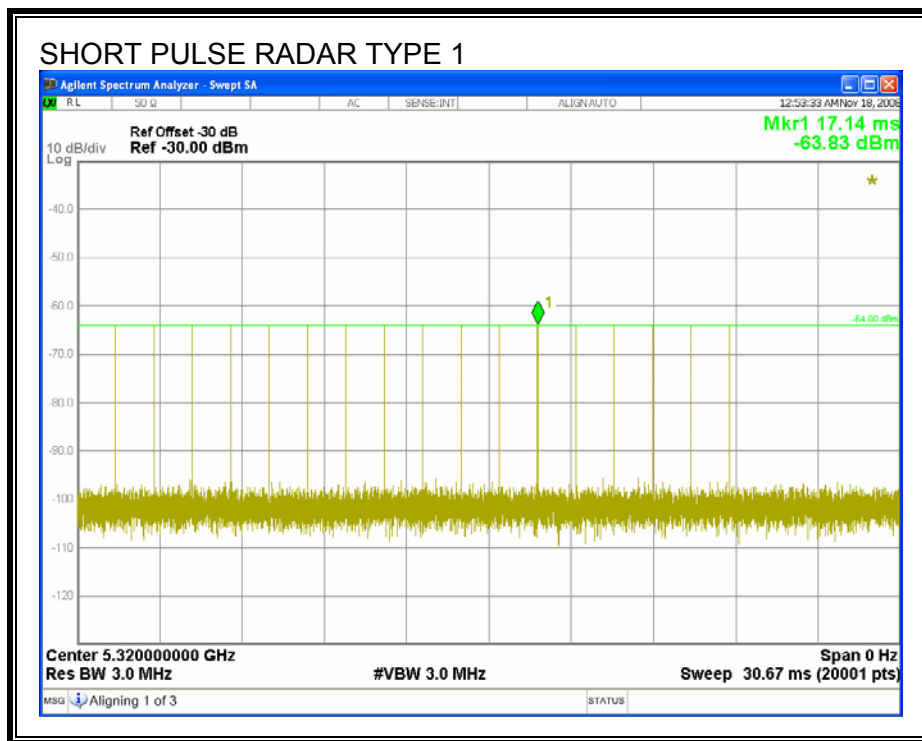

PLOT OF WLAN TRAFFIC FROM SLAVE

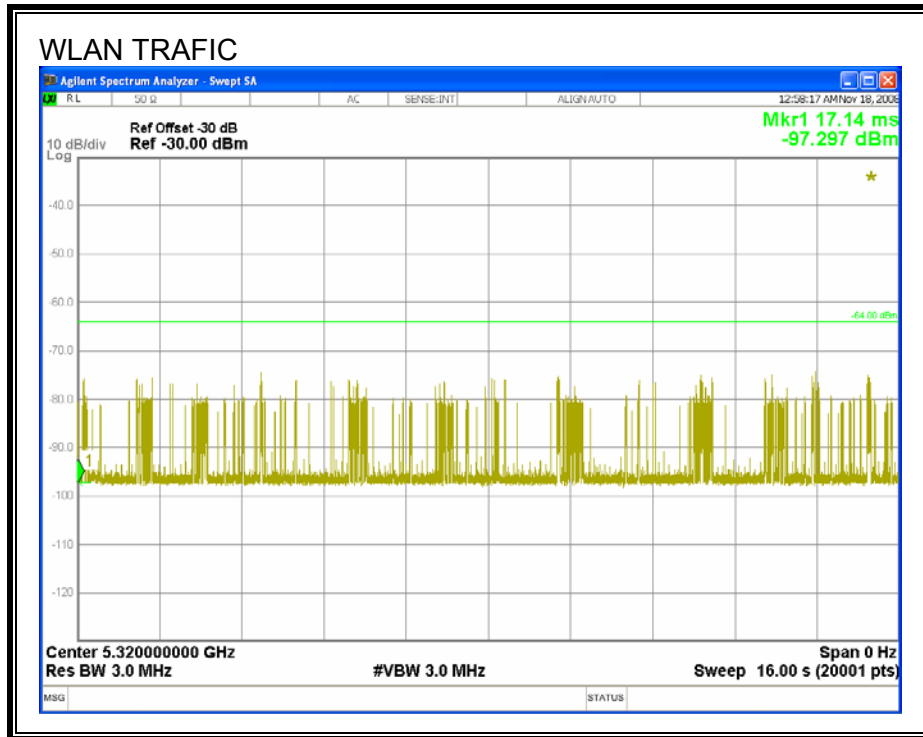

5.2.3. CHANNEL MOVE TIME AND CHANNEL CLOSING TRANSMISSION TIME

REPORTING NOTES

The reference marker is set at the end of last radar pulse.

The delta marker is set at the end of the last WLAN transmission following the radar pulse. This delta is the channel move time.

The aggregate channel closing transmission time is calculated as follows:

Aggregate Transmission Time =
(Number of analyzer bins showing transmission) * (dwell time per bin)

FCC

The observation period over which the aggregate time is calculated
Begins at (Reference Marker + 200 msec)
and
Ends no earlier than (Reference Marker + 10 sec).

IC

The observation period over which the aggregate time is calculated
Begins at (Reference Marker)
and
Ends no earlier than (Reference Marker + 10 sec).

RESULTS

Agency	Channel Move Time (sec)	Limit (sec)
FCC / IC	0.022	10

Agency	Aggregate Channel Closing Transmission Time (msec)	Limit (msec)
FCC	0.0	60
IC	21.6	260

CHANNEL MOVE TIME RESULTS

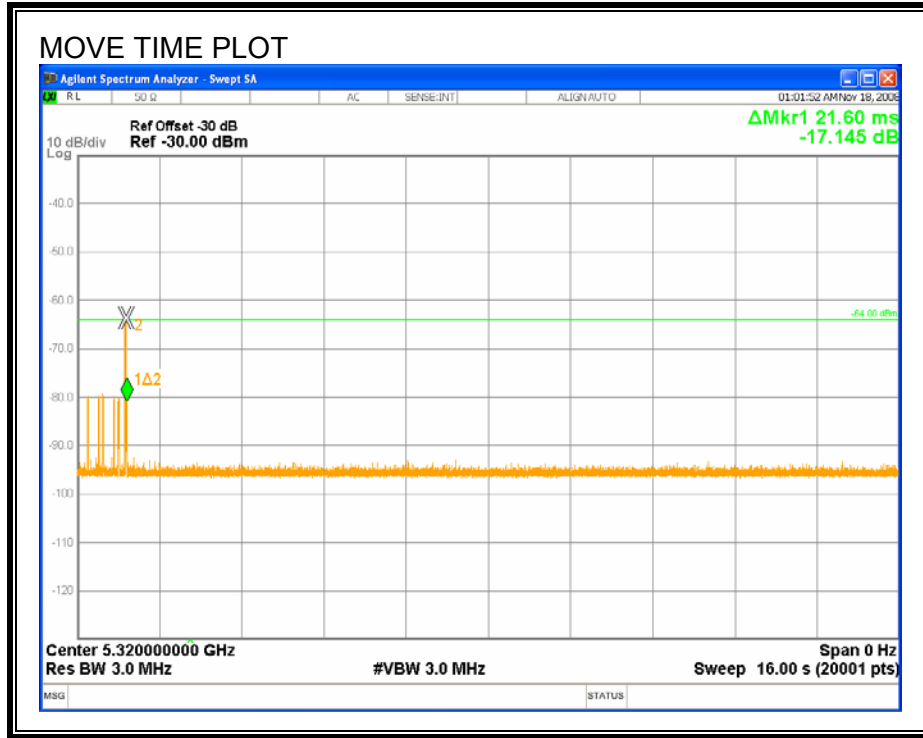

CHANNEL CLOSING TIME RESULTS

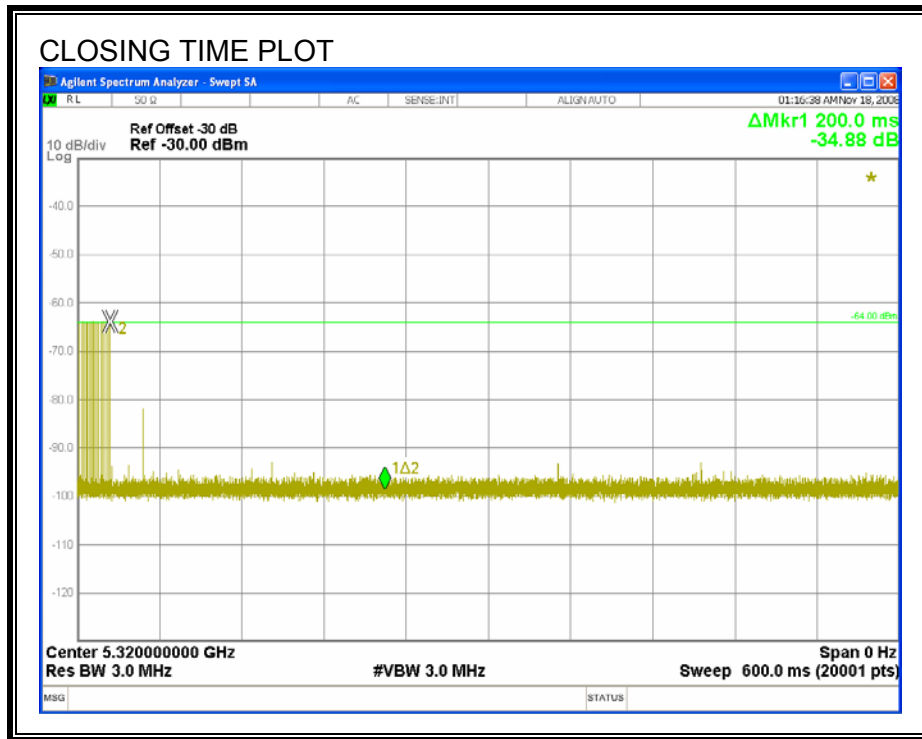

FCC AGGREGATE CHANNEL CLOSING TRANSMISSION TIME RESULTS

No transmissions are observed during the aggregate monitoring period.

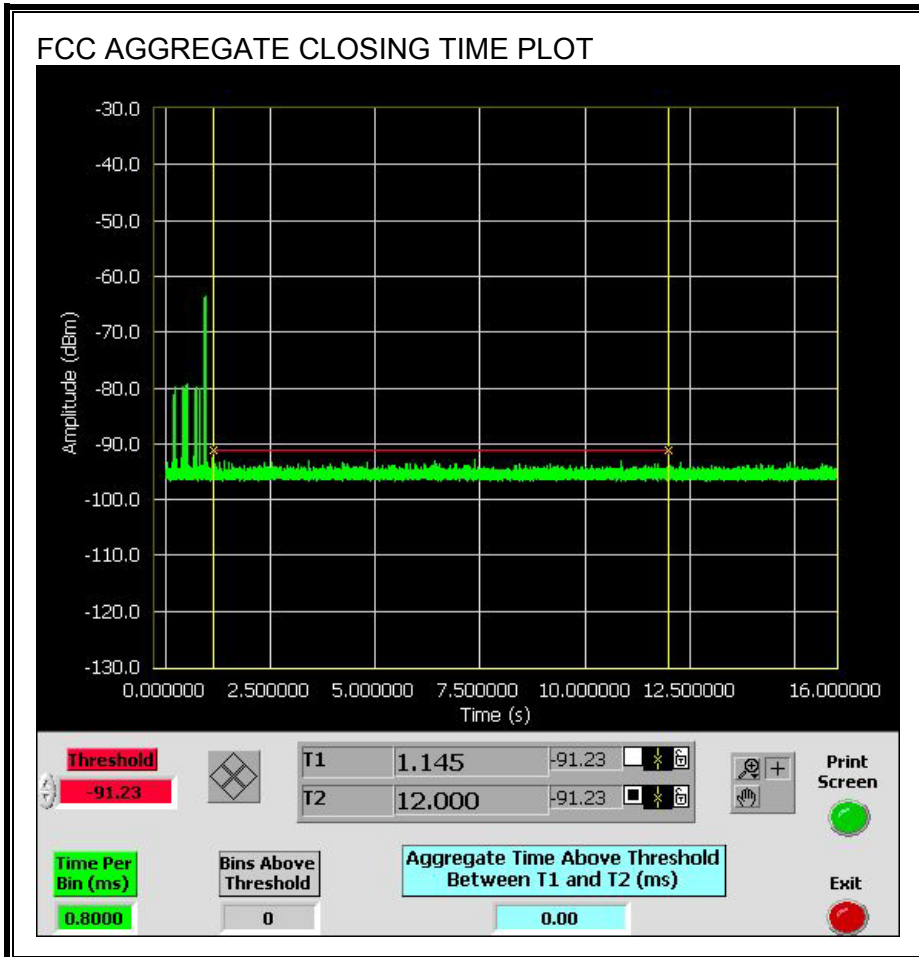

IC AGGREGATE CHANNEL CLOSING TRANSMISSION TIME RESULTS

Only intermittent transmissions are observed during the aggregate monitoring period.

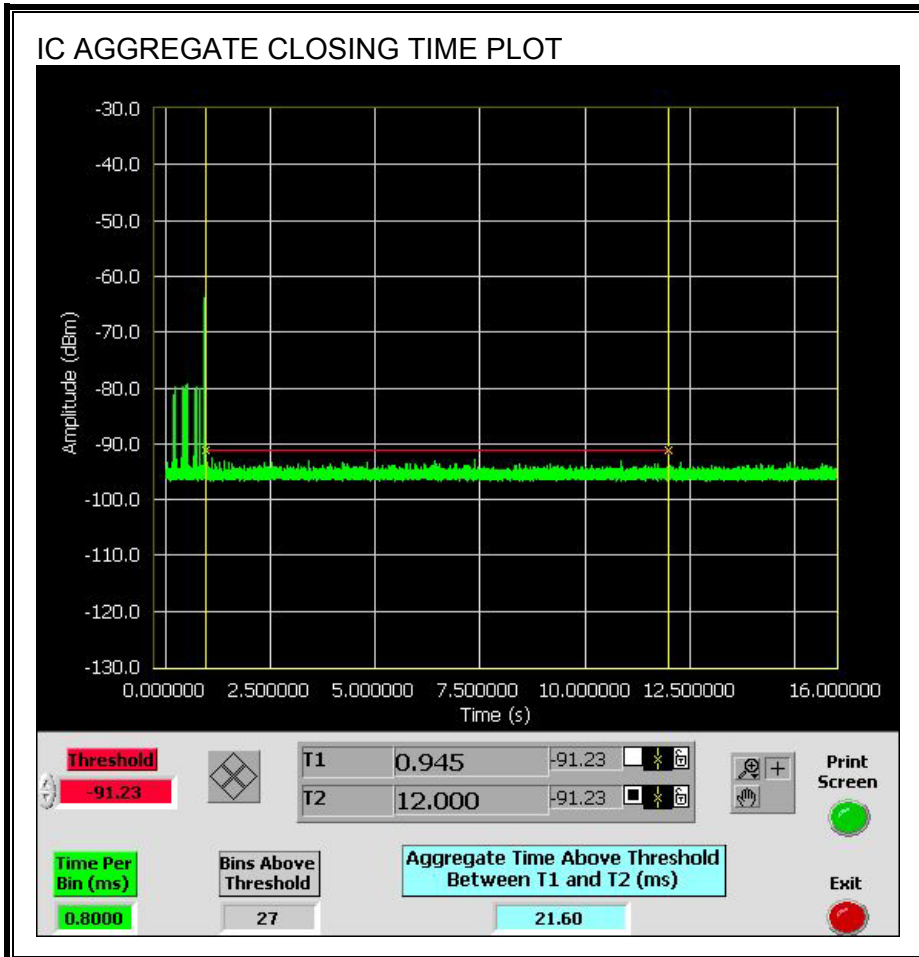

5.2.4. NON-OCCUPANCY PERIOD

RESULTS

No EUT transmissions were observed on the test channel during the 30 minute observation time.

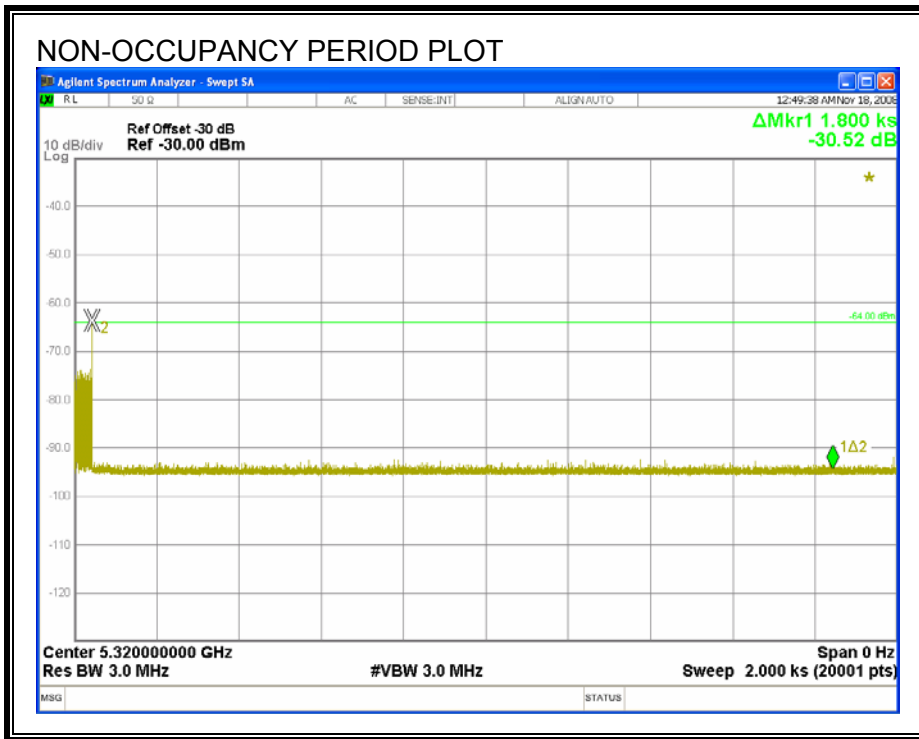

5.3. RESULTS FOR 40 MHz BANDWIDTH

5.3.1. TEST CHANNEL AND METHOD

All tests were performed at a channel center frequency of 5310 MHz. Measurements were performed using conducted test methods.

5.3.2. PLOTS OF RADAR WAVEFORM, AND WLAN TRAFFIC

PLOTS OF RADAR WAVEFORMS

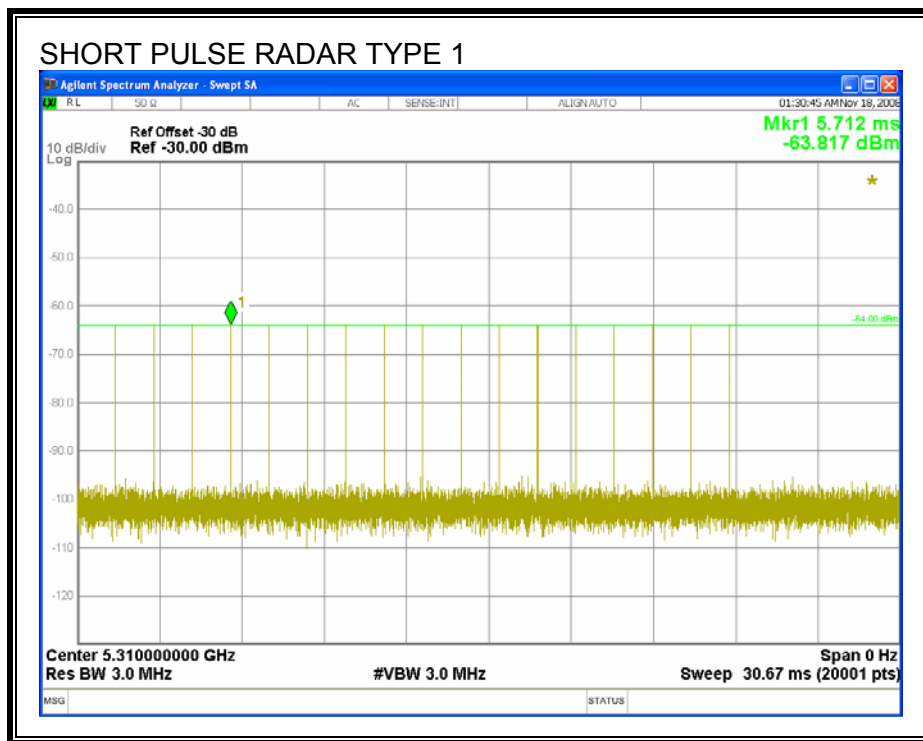

PLOT OF WLAN TRAFFIC FROM SLAVE

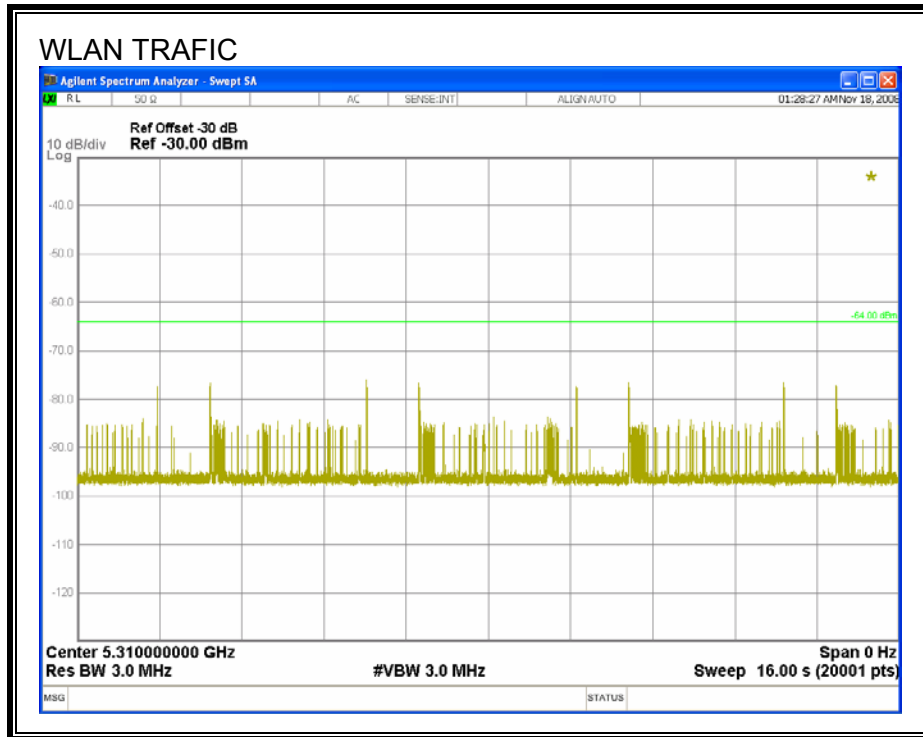

5.3.3. CHANNEL MOVE TIME AND CHANNEL CLOSING TRANSMISSION TIME

REPORTING NOTES

The reference marker is set at the end of last radar pulse.

The delta marker is set at the end of the last WLAN transmission following the radar pulse. This delta is the channel move time.

The aggregate channel closing transmission time is calculated as follows:

Aggregate Transmission Time =
 (Number of analyzer bins showing transmission) * (dwell time per bin)

FCC

The observation period over which the aggregate time is calculated
 Begins at (Reference Marker + 200 msec)
 and
 Ends no earlier than (Reference Marker + 10 sec).

IC

The observation period over which the aggregate time is calculated
 Begins at (Reference Marker)
 and
 Ends no earlier than (Reference Marker + 10 sec).

RESULTS

Agency	Channel Move Time (sec)	Limit (sec)
FCC / IC	0.000	10

Agency	Aggregate Channel Closing Transmission Time (msec)	Limit (msec)
FCC	0.0	60
IC	0.0	260

CHANNEL MOVE TIME RESULTS

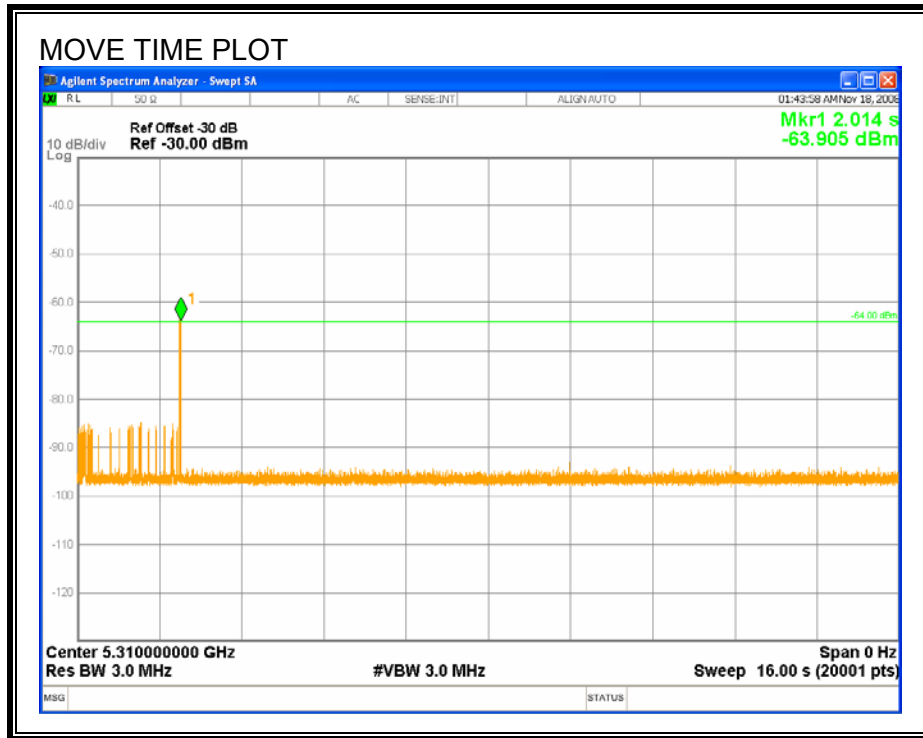

CHANNEL CLOSING TIME RESULTS

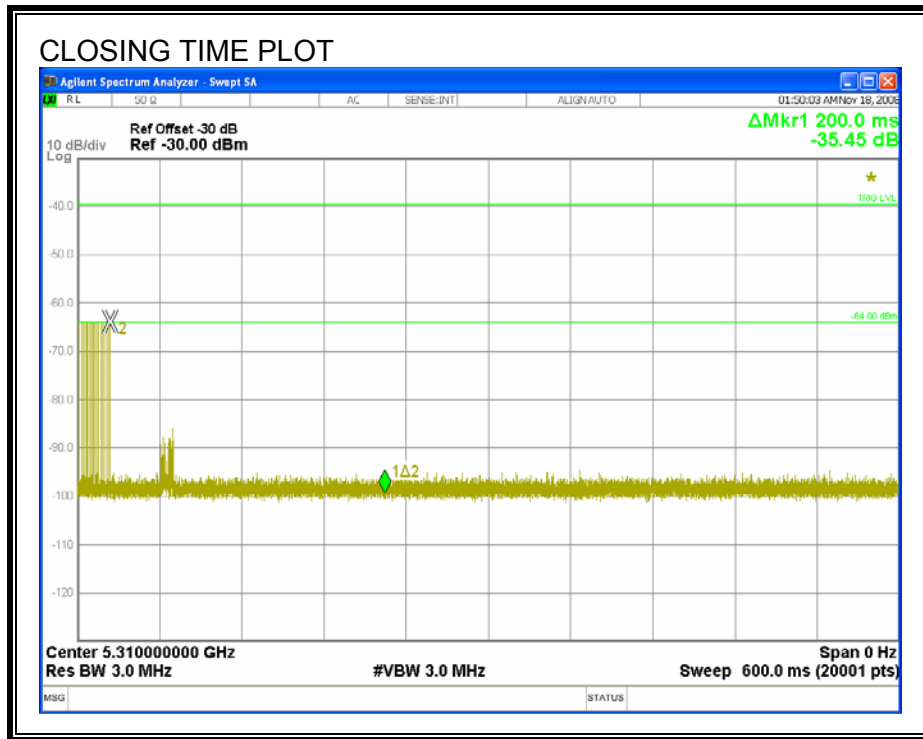

FCC AGGREGATE CHANNEL CLOSING TRANSMISSION TIME RESULTS

No transmissions are observed during the aggregate monitoring period.

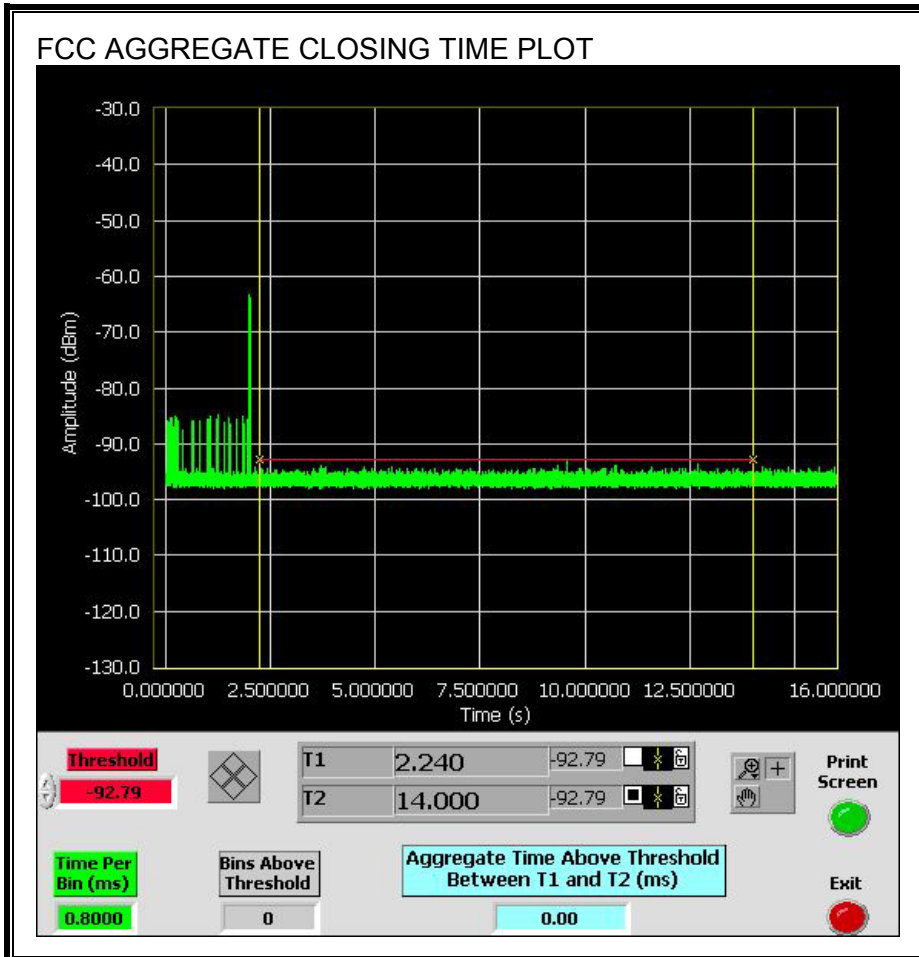

IC AGGREGATE CHANNEL CLOSING TRANSMISSION TIME RESULTS

Only intermittent transmissions are observed during the aggregate monitoring period.

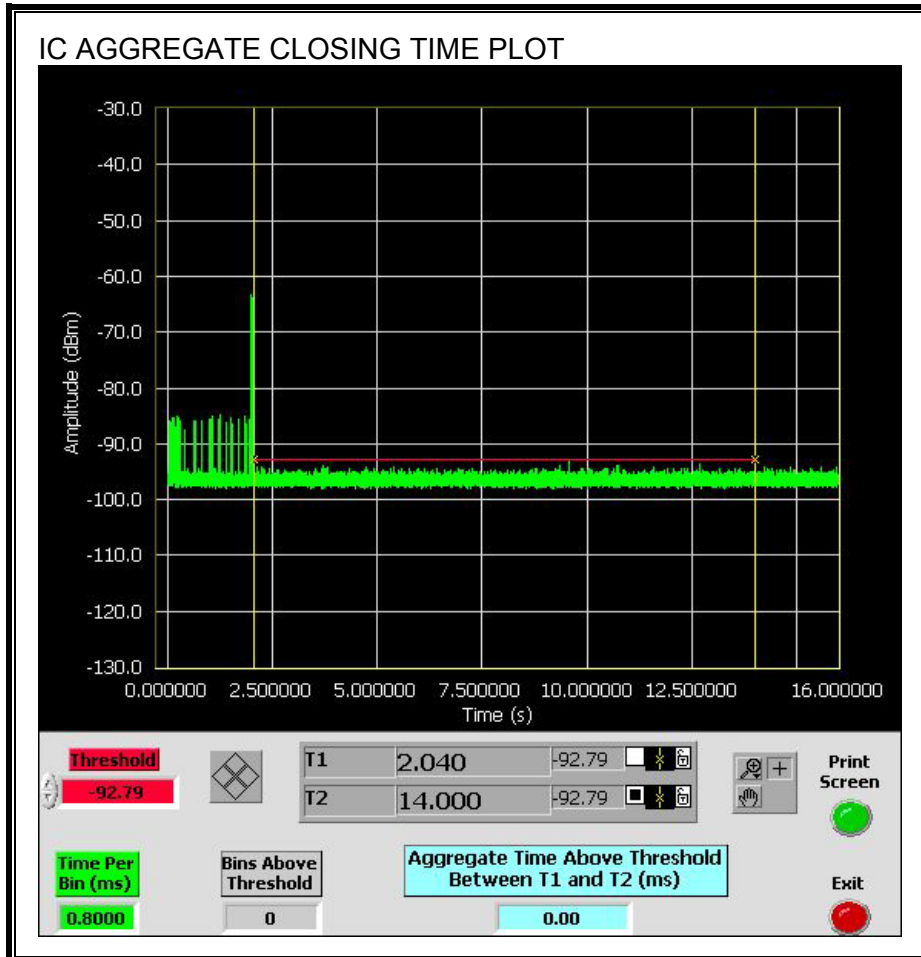

5.3.4. NON-OCCUPANCY PERIOD

RESULTS

No EUT transmissions were observed on the test channel during the 30 minute observation time.

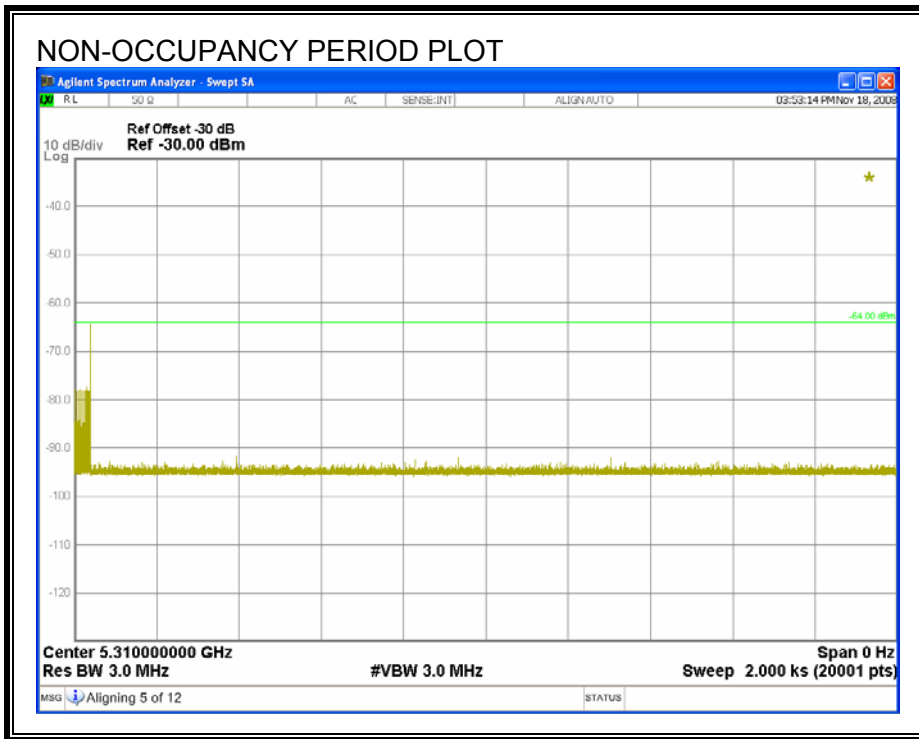

6. SETUP PHOTOS

DFS MEASUREMENT SETUP

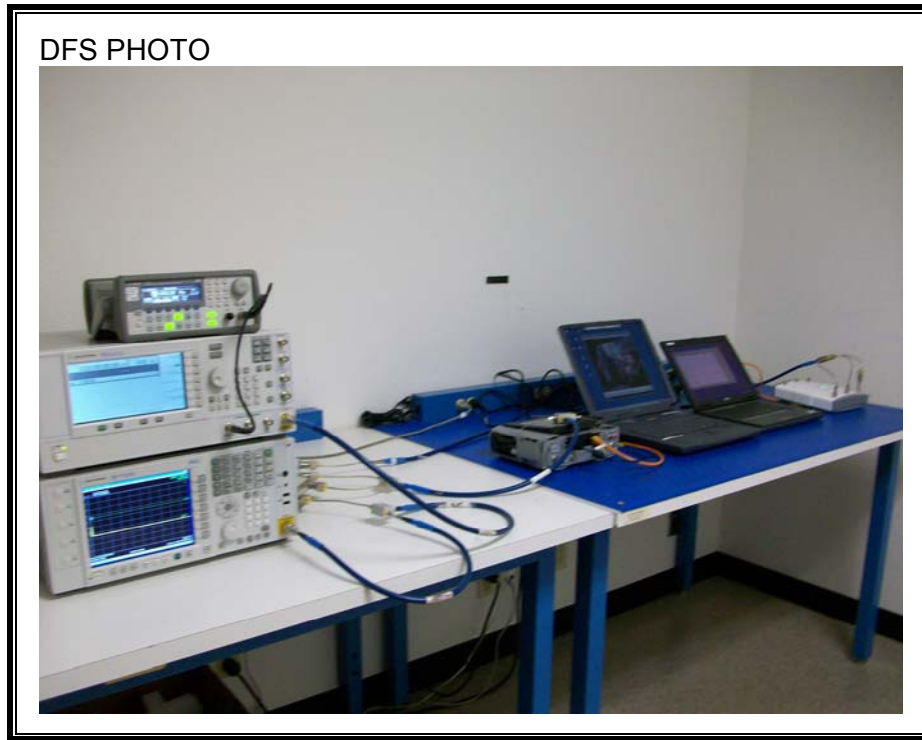

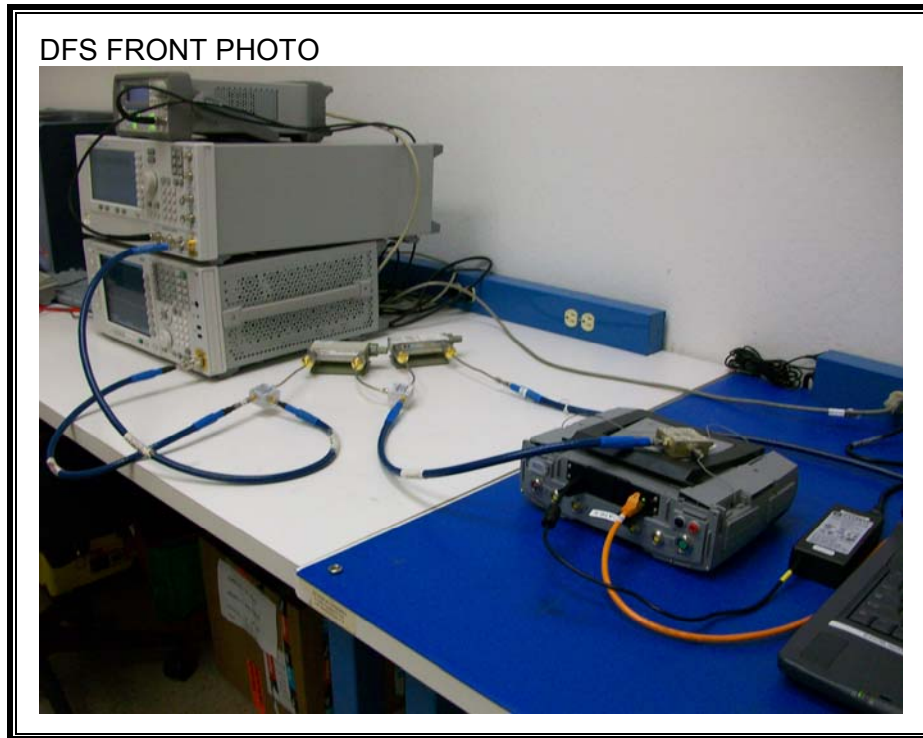

END OF REPORT