

This document/data record is the property of PCI Private Limited, and is confidential material.

3RD ANGLE 	MATERIAL OR SOURCE See Note	GENERAL TOLERANCE	±0.5
		ONE DECIMAL PL	
SCALE 1 : 1	FINISH See Note	TWO DECIMAL PL	
		ANGULAR	

REVISIONS ARE INDICATED BY TRIANGLED LETTERS
ALL DIMENSIONS IN MILLIMETRES

REV	DESCRIPTION	DATE
A	Initial Issue	28 May 2019

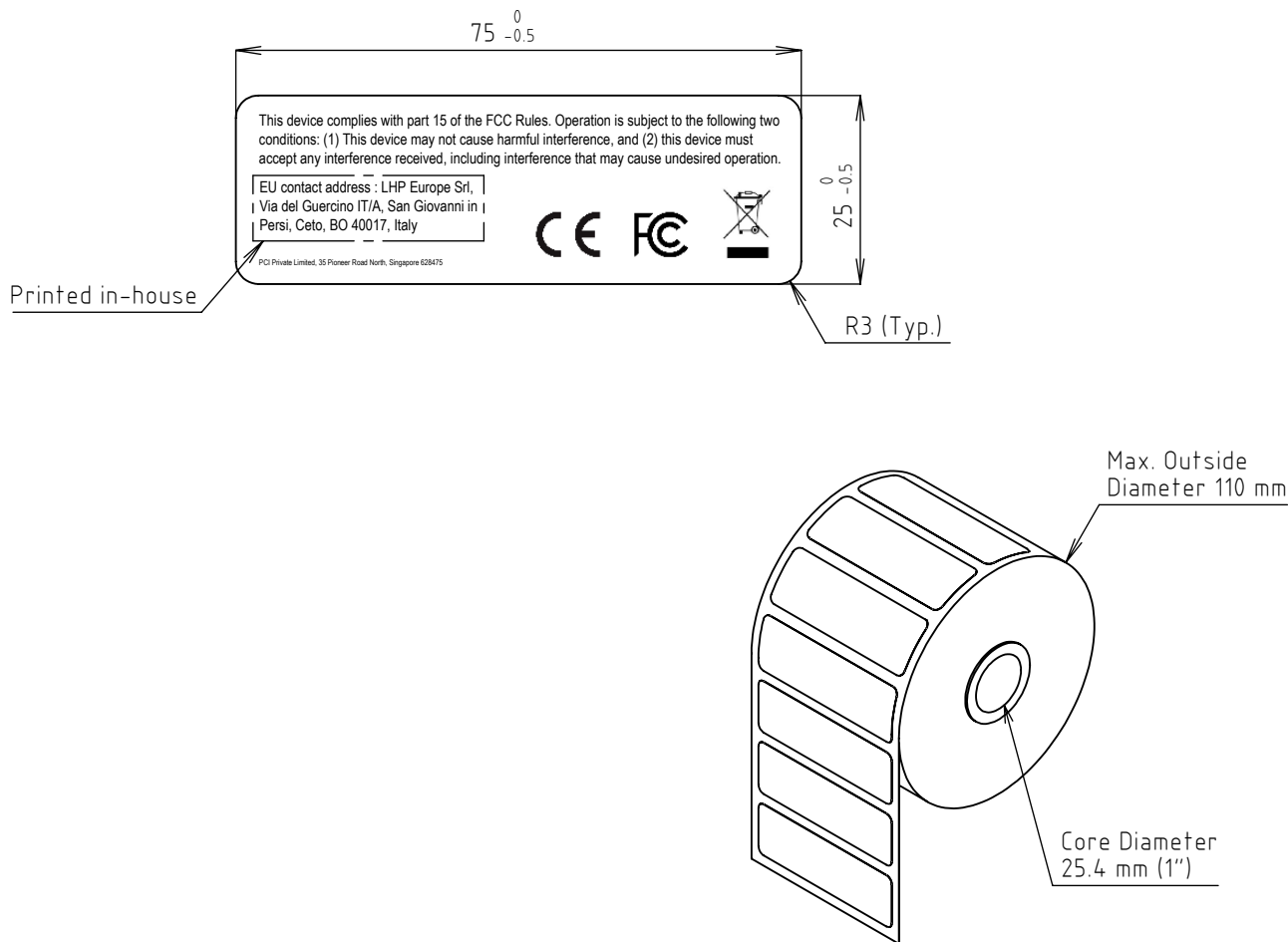



- NOTE:
- Material :
Printable Substrate : 3M 7931 Sheet Label Stock
Facestock : 2.0 mil PET, gloss white
Adhesive tape : 0.8 mil type 400 Acrylic
 - Temperature rating : label material and adhesive must be suitable for continuous use from -40°C to +85°C
 - Parts to be manufactured in accordance with UL 969 standard
 - Durability test to comply with UL 1950 standard third edition, paragraph 1.7.15
 - Labels shall be kiss cut multiple up in roll(s)
 - Part must be recast RoHS 2011/65/EU compliant

DRAWN BY TELLY K.	DATE 28 May 2019
APPROVED BY (ORIGINATOR'S DEPT. HEAD) T. NATHAN	
RELEASED BY (ORIGINATOR) SYED SHARFUDEEN	
pci	
TITLE LABEL TP1 PRODUCT ID-CE	
CUSTOMER	
SPEC OR DWG NUMBER HQLB000300	SHT 1
	1 SHT

This document/data record is the property of PCI Private Limited, and is confidential material.

3RD ANGLE 	MATERIAL OR SOURCE See Note	GENERAL TOLERANCE ±0.5
	SCALE 1 : 1	FINISH See Note
		ONE DECIMAL PL
		TWO DECIMAL PL
		ANGULAR

REV	DESCRIPTION	DATE
-----	-------------	------

Model : PCI-TP1
 MCN : P18-TP001-300
 SN : 100YYWWXXXXXX

 IMEI : XXXXXXXXXXXXXXX

 Input : DC 12V === 0.5A or 24V === 0.25A
 MADE IN INDONESIA

ICC ID : XXXXXXXXXXXXXXX
 FCC ID : LY5-PCITP1
 IC : 5113A-PCITP1
 Class : CAN ICES-3(A)/NMB-3(A)
 Contains FCC ID : LY5-PCITP100
 Contains IC : 5113A-PCITP100

2D Barcode

REVISIONS ARE INDICATED BY TRIANGLED LETTERS
ALL DIMENSIONS IN MILLIMETRES

NOTES :

1. Refer to separate drawing for blank label material spec (HQLB000100)
2. This part must comply with RoHS

Label Contents :

Serial Number : 100YYWWXXXXXX
 100 - Hardware Version
 YYWW - Date Code
 XXXXXX- 6 Digits Running Number
 Starting from 000001

MCN : P18-TP001-100
 P - PCI Design
 18 - FY18 Project
 TP001 - Product Code
 100 - Build Version
 (i.e. 100 for P1, 120 for P1.2 build, ...)

Content	Info	Format	Font	Size
Model	PCI-TP1	7 characters	Arial Narrow, Bold	8
MCN	P18-TP001-200	13 characters	Arial Narrow, Bold	6
Serial Number	100YYWWXXXXXX	13 characters	Arial Narrow, Bold	6
Serial Number Barcode	Barcode Symbiology Code 128	13 characters	-	-
IMEI	XXXXXXXXXXXXXX	15 characters	Arial Narrow	6
IMEI Barcode	Barcode Symbiology Code 128	15 characters	-	-
Contains FCC ID	LY5-PCITP100	12 characters	Arial Narrow	5
Contains IC	5113A-PCITP100	14 characters	Arial Narrow	5
FCC ID	LY5-PCITP1	10 characters	Arial Narrow	6
IC	5113A-PCITP1	12 characters	Arial Narrow	6
Class	CAN ICES-3(A)/NMB-3(A)	22 characters	Arial Narrow	6
ICC ID	XXXXXXXXXXXXXX	20 characters	Arial Narrow	6
Input	DC 12V === 0.5A or 24V === 0.25A	-	Arial Narrow	5
Country of Origin	MADE IN INDONESIA	17 characters	Arial Narrow	5
2D Barcode	See 2D Barcode Definition	-	-	-

2D Barcode Contents :

Position	Description	Content
1-13	MCN	13 characters MCN #
14	Semicolon	;
15-27	Serial Number	13 characters Serial Number
28	Semicolon	;
29-43	IMEI	15 characters IMEI
44	Semicolon	;
45-64	ICC ID	20 characters ICC ID
65	Semicolon	;
66-77	MAC Address (Ethernet)	12 digits MAC Address
78	Semicolon	;
79-90	MAC Address (Bluetooth Modem)	12 digits MAC Address
91	Semicolon	;
92-103	MAC Address (Wi-Fi Modem)	12 digits MAC Address
104	Semicolon	;
105-121	MADE IN INDONESIA	17 characters Country of Origin
122	Semicolon	;

A	Initial Issue	28 May 2019
---	---------------	-------------

DRAWN BY TELLY K.	DATE 28 May 2019
APPROVED BY (ORIGINATOR'S DEPT. HEAD) T. NATHAN	
RELEASED BY (ORIGINATOR) SYED SHARFUDEEN	
	
TITLE Printing for TP1 ID LABEL	
CUSTOMER	
SPEC OR DWG NUMBER	SHT 1 1 SHT