

# **Intentional Radiator Test Report**

**Test Standards:  
FCC Part 15 (Subpart C – Intentional Radiators)  
Industry Canada RSS-210**

**Prepared For:  
Socket Communications, Inc.  
39700 Eureka Drive  
Newark, CA 94560**

**Equipment Under Test:  
SDIO Wi-Fi Card**

**Model:  
GO WI-FI! P300-EXT**

**Prepared by:**



**44366 S. Grimmer Blvd.  
Fremont, CA 94538  
USA**

# TABLE OF CONTENTS

1. CUSTOMER INFORMATION	3
2. EUT AND ACCESSORY INFORMATION	4
3. SUMMARY OF TEST RESULTS	5
4. STANDARDS AND MEASUREMENT METHODS	6
5. TEST SETUPS	7
6. TEST RESULTS	9
7. TEST EQUIPMENT	68
8. ANNEX 1 – RADIATED SPURIOUS EMISSIONS [MODULAR SETUP]	

## 1.0 CUSTOMER INFORMATION

<b>Test Laboratory:</b>	EMCE Engineering 44366 S. Grimmer Blvd. Fremont, CA 94538 USA  Tel: 510-490-4307 Fax: 510-490-3441 bob@universalcompliance.com
<b>FCC registration number</b>	0007-1981-20
<b>Customer:</b>	Socket Communications, Inc. 39700 Eureka Drive Newark, CA  Tel: 510-933-3077 Fax: 510-933-3001
<b>Contact Person:</b>	Thomas Moyland
<b>Receipt of EUT:</b>	12/20/07
<b>Test plan reference:</b>	FCC Part 2, 15 (15.247) / IC RSS-210
<b>FCC ID:</b>	LUB-P300SD-1
<b>IC #:</b>	2529A-P300SD1
<b>Date of testing:</b>	12/20/07 – 1/31/08
<b>Date of Report:</b>	2/7/08

*The tests listed in this report have been completed to demonstrate compliance to the CFR 47 Section 15.247, as well as Industry Canada Radio Standard RSS-210, Issue 7.*

Contents approved:

Name: Bob Cole Title: President

## 2.0 EUT AND ACCESSORY INFORMATION

### EUT description

The EUT is a Socket Communications, Inc. **SDIO WiFi Card, M/N: GO WI-FI! P300-EXT.**

### EUT and accessories

The table below lists all EUTs and accessories used in the tests. Later in this report, only numbers in the last column are used to refer to the devices in each test.

### Software

The computers were equipped with test software provided by the customer. The software was used to control the EUT in the tests.

	Name	Type	S/N	Number
<b>EUT</b>	<b>CF Wi-Fi Card</b>	<b>GO WI-FI! P300-EXT</b>	N/A	E0001
<b>Accessories</b>	Laptop Computer	Compaq Presario M/N: 1694	3882A744	S0001
<b>Software</b>	MediaTek	WLAN RF Test	N/A	N/A

### EUT Information

Product Specification	Description
Model Name	GO WI-FI! P300-EXT
Type of Modulation	DSS
Number of Channels	11
Operating Frequency Range	2412 – 2462 MHz
Type of Equipment	Communications, Portable, Modular
Extreme Operating Temperature Range	-20 C – 55 C
Extreme Operating Voltage Range	108 – 132 VAC
Transmitter Method of Frequency Generation	Synthesized
Transmitter Aggregate Data Rate	>250kbps
Transmitter Duty Type	Continuous
Continuous Operation for Testing Purposes?	Yes

### Antenna Information

Antenna #	Model Name	Antenna Type	Description	Connector	Gain (dBi)
1	N/A	Printed	External	0.81 mm MHF	6.0

### 3.0 SUMMARY OF TEST RESULTS

RSS 210 Section	CFR Section		Results
A8.4(2)	15.245 (b)(1)	Peak output power (Radiated Emissions)	PASSED
A8.2(b)	15.247 (e)	Power Density	PASSED
A8.1(a)	15.247 (a)(2)	20 dB Bandwidth	PASSED
A8.1(b)	15.247(a)(1)	Center Frequency	PASSED
A8.5	15.247, c	Band-edge compliance of RF emissions	PASSED
2.2, 2.7	15.247, (4)(c)	Restricted Band	PASSED
A8.5	15.247,c	Spurious radiated emissions	PASSED

PASS            The EUT passed that particular test.  
FAIL            The EUT failed that particular test.

## **4.0 STANDARDS AND MEASUREMENT METHODS**

The tests were performed in guidance of CFR 47 section 15.247, FCC Public Notice DA 00-705 (March 30, 2000), FCC Report & Order 97-114 (April 10, 1997), and ANSI C63.4 (2003). Deviations, modifications or clarifications (if any) to above mentioned documents are written in each section under “Test method”. For the test equipment, see device list in the end of this test.

### **4.1 Selection of operation mode for tests**

Before tests, several operation modes, and modulation patterns were tried. The worst case was selected for each test and those results reported.

## 5.0 TEST SETUPS

To fulfill all requirements for the testing, total of two different test setups were used. One EUT was used, unmodified for radiated tests.

SMA connector added in place of internal antenna for Antenna Conducted measurements.

### Setup A (Antenna Conducted measurements)

#### Operational description

#### ANTENNA CONDUCTED EMISSIONS MEASUREMENTS

The EUT was connected to the Laptop Computer through the serial port (COM1), the antenna bypassed and the SMA Cable connected to the Spectrum Analyzer. This setup was used for the **PEAK POWER OUTPUT, POWER DENSITY, 6 dB BW, BAND-EDGE COMPLIANCE, and RESTRICTED BAND** measurements.

#### *Block Diagram*

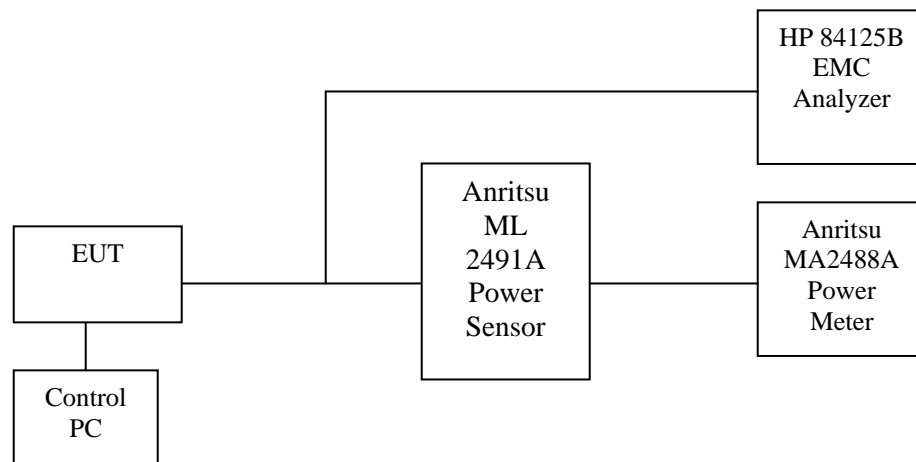

The solid lines are coaxial cables and the dashed lines are either EUT insertion to the test board or control cables between test setup devices. The measurement results were adjusted with the attenuation of the coaxial cable.

## Setup B (Radiated measurements)

### Operational description

#### RADIATED EMISSIONS MEASUREMENTS

This setup was used in radiated emissions measurements.

The EUT was tested in 3 orthogonal orientations.

Worst case data is presented.

THIS SETUP USED FOR *RADIATED SPURIOUS EMISSIONS*

### *Block diagram*

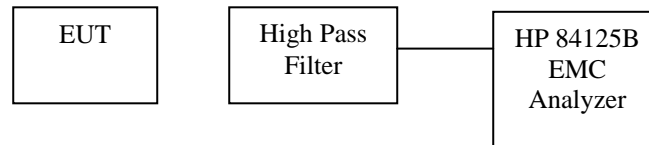

Note: The high –pass filter is used for the Radiated Spurious emissions above 2.4835 GHz. A pass-thru connector is used for Radiated Spurious emissions measurements from 30 MHz – 2.4 GHz.

The solid lines are coaxial cables and the dashed lines are either EUT insertion to the test board or control cables between test setup devices.



## 6.0 TEST RESULTS

The measurement results were adjusted for the attenuation of the cable between the EUT connector and receiver.

### PEAK OUTPUT POWER

Peak Output Power [CFR 47, 15.247(b)(1) and RSS-210 6.2.2(o)]

<b>EUT</b>	<b>GO WI-FI! P300-EXT</b>
<b>Test setup</b>	A (conducted)
<b>Temp, Humidity, Air Pressure</b>	58° F, 30.28
<b>Date of Measurement</b>	1/20/08
<b>Measured by</b>	Bob Cole
<b>Result</b>	PASSED

#### Modes Tested (Maximum Power Output Data Presented)

Modulation	Data Rate (MB/Sec)
OFDM	54
OFDM	6
CCK	11
CCK	5.5

#### Limits and results

#### PEAK OUTPUT POWER

EUT Channel Info	Limit (dBm)	Test results (dBm)
2412 OFDM 6 MB/S	30.0	11.57
2437 OFDM 6 MB/S	30.0	11.83
2467 OFDM 6 MB/S	30.0	11.45

Note: Peak Output Power measured using the Anritsu MA2488A Power Meter / ML 2491A Power Sensor in 802.11b (CCK) and 802.11g (OFDM) Modes per FCC Publication Number 558074, "New Guidance on Measurements for Digital Transmissions Systems in Section 15.247" Maximum Power output listed here.

## POWER DENSITY

### Peak Output Power [R&O 97-114]

<b>EUT</b>	<b>GO WI-FI! P300-EXT</b>
<b>Test setup</b>	A (conducted)
<b>Temp, Humidity, Air Pressure</b>	60° F, 30.26
<b>Date of Measurement</b>	1/15/08
<b>Measured by</b>	Bob Cole
<b>Result</b>	PASSED

### Modes Tested (Worst Case Data Presented)

Modulation	Data Rate (MB/Sec)
OFDM	54
OFDM	48
OFDM	36
OFDM	24
OFDM	12
OFDM	9
OFDM	6
CCK	11
CCK	5.5

### Limits and results

#### POWER DENSITY

EUT Channel	Limit (dBm)
2412 OFDM 6 MB/S	8.0
2437 OFDM 6 MB/S	8.0
2467 OFDM 6 MB/S	8.0

#### Worst Case Data presented for each channel.

Note: Power Spectral Density measured for both CCK and OFDM modulation on Channels 1, 6, and 11, using “PSD Option 1” per FCC Publication Number 558074, “New Guidance on Measurements for Digital Transmissions Systems in Section 15.247” Test software divides span into 5 sweeps of 100 mS each for 500 mS total Sweep Time.

## PSD – Channel 1 / 2412 MHz / OFDM Mod / 6 MBS Data Rate

Test Location: EMCE Engineering •44366 S. Grimmer Blvd • Fremont, CA 94538 • 510-490-4307

Customer: **SocketCommunications, Inc.**  
 Specification: **DSS PSD 2.41785**  
 Work Order #: **2758** Date: 1/15/2008  
 Test Type: **Conducted Emissions** Time: 12:01:37 PM  
 Equipment: **CF WLAN** Sequence#: 2  
 Manufacturer: **SocketCommunications** Tested By: **Bob Cole**  
 Model: **Go WiFi! P300-EXT** N/A  
 S/N:

**Test Equipment:**

Function	S/N	Calibration Date	Cal Due Date	Asset #
----------	-----	------------------	--------------	---------

**Equipment Under Test (\* = EUT):**

Function	Manufacturer	Model #	S/N
CF WLAN*	SocketCommunications	Go WiFi! P300-EXT	

**Support Devices:**

Function	Manufacturer	Model #	S/N
----------	--------------	---------	-----

**Test Conditions / Notes:**

RBW = 3 kHz VBW = 10 kHz Sweep Time = 500 sec Data Rate = 6 MBS
---

**Transducer Legend:**

T1=dBuV - dBm conversion
--------------------------

**Measurement Data:** Reading listed by margin. Test Lead: Antenna

#	Freq MHz	Rdng dB $\mu$ V	T1 dB	dB	dB	dB	Dist Table	Corr dBm	Spec dBm	Margin dB	Polar Anten
1	2417.883M	82.9	-107.0				+0.0	-24.1	8.0	-32.1	Anten
2	2418.188M	82.7	-107.0				+0.0	-24.3	8.0	-32.3	Anten
3	2418.240M	82.7	-107.0				+0.0	-24.3	8.0	-32.3	Anten
4	2417.641M	82.4	-107.0				+0.0	-24.6	8.0	-32.6	Anten
5	2417.273M	82.1	-107.0				+0.0	-24.9	8.0	-32.9	Anten
6	2417.612M	81.8	-107.0				+0.0	-25.2	8.0	-33.2	Anten
7	2417.939M	81.8	-107.0				+0.0	-25.2	8.0	-33.2	Anten
8	2418.288M	81.7	-107.0				+0.0	-25.3	8.0	-33.3	Anten
9	2418.220M	81.5	-107.0				+0.0	-25.5	8.0	-33.5	Anten
10	2418.214M	81.4	-107.0				+0.0	-25.6	8.0	-33.6	Anten

EMCE Engineering Date: 1/15/2008 Time: 12:01:37 PM SocketMobile, Inc. WO#: 2721  
DSS PSD 2.41785 Test Lead: Antenna N/A Sequence#: 2

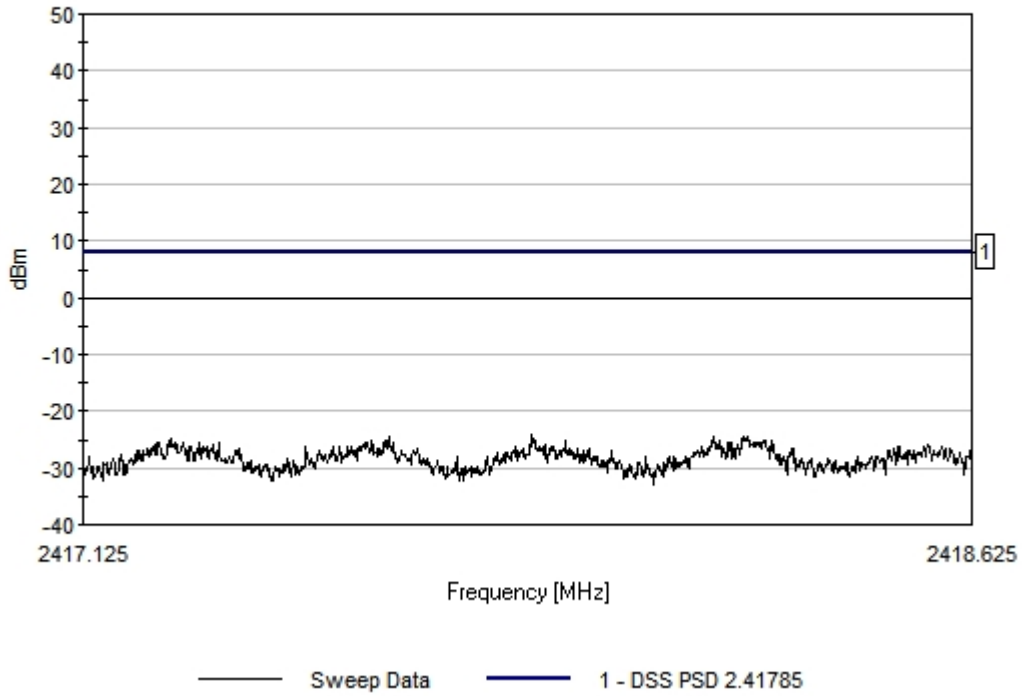

## PSD – Channel 6 / 2437 MHz / OFDM Mod / 6 MBS Data Rate

Test Location: EMCE Engineering •44366 S. Grimmer Blvd • Fremont, CA 94538 • 510-490-4307

Customer: **Socket Communications, Inc.**

Specification: **DSS PSD 2.41785**

Work Order #: **2721**

Date: 1/15/2008

Test Type: **Conducted Emissions**

Time: 3:12:43 PM

Equipment: **CF WLAN**

Sequence#: 4

Manufacturer: **SocketCommunications**

Tested By: **Bob Cole**

Model: **Go WiFi! P300-EXT**

N/A

S/N:

**Test Equipment:**

Function	S/N	Calibration Date	Cal Due Date	Asset #
----------	-----	------------------	--------------	---------

**Equipment Under Test (\* = EUT):**

Function	Manufacturer	Model #	S/N
CF WLAN*	SocketCommunications	Go WiFi! P300-EXT	

**Support Devices:**

Function	Manufacturer	Model #	S/N
----------	--------------	---------	-----

**Test Conditions / Notes:**

2437 MHz RBW = 3 kHz VBW = 10 kHz Sweep Time = 500 sec Data Rate = 6 MBS
--

**Transducer Legend:**

T1=dBuV - dBm conversion
--------------------------

**Measurement Data:** Reading listed by margin. Test Lead: Antenna

#	Freq MHz	Rdng dBuV	T1 dB				Dist Table	Corr dBm	Spec dBm	Margin dB	Polar Ant
1	2417.878M	51.6	-107.0				+0.0	-55.4	8.0	-63.4	Anten
2	2417.281M	51.3	-107.0				+0.0	-55.7	8.0	-63.7	Anten
3	2418.215M	51.3	-107.0				+0.0	-55.7	8.0	-63.7	Anten
4	2418.526M	51.3	-107.0				+0.0	-55.7	8.0	-63.7	Anten
5	2418.288M	50.6	-107.0				+0.0	-56.4	8.0	-64.4	Anten
6	2417.579M	50.5	-107.0				+0.0	-56.5	8.0	-64.5	Anten
7	2417.948M	50.4	-107.0				+0.0	-56.6	8.0	-64.6	Anten
8	2417.630M	50.2	-107.0				+0.0	-56.8	8.0	-64.8	Anten
9	2417.996M	50.1	-107.0				+0.0	-56.9	8.0	-64.9	Anten
10	2418.451M	49.8	-107.0				+0.0	-57.2	8.0	-65.2	Anten

EMCE Engineering Date: 1/15/2008 Time: 3:12:43 PM SocketMobile, Inc. WO#: 2721  
DSS PSD 2.41785 Test Lead: Antenna N/A Sequence#: 4

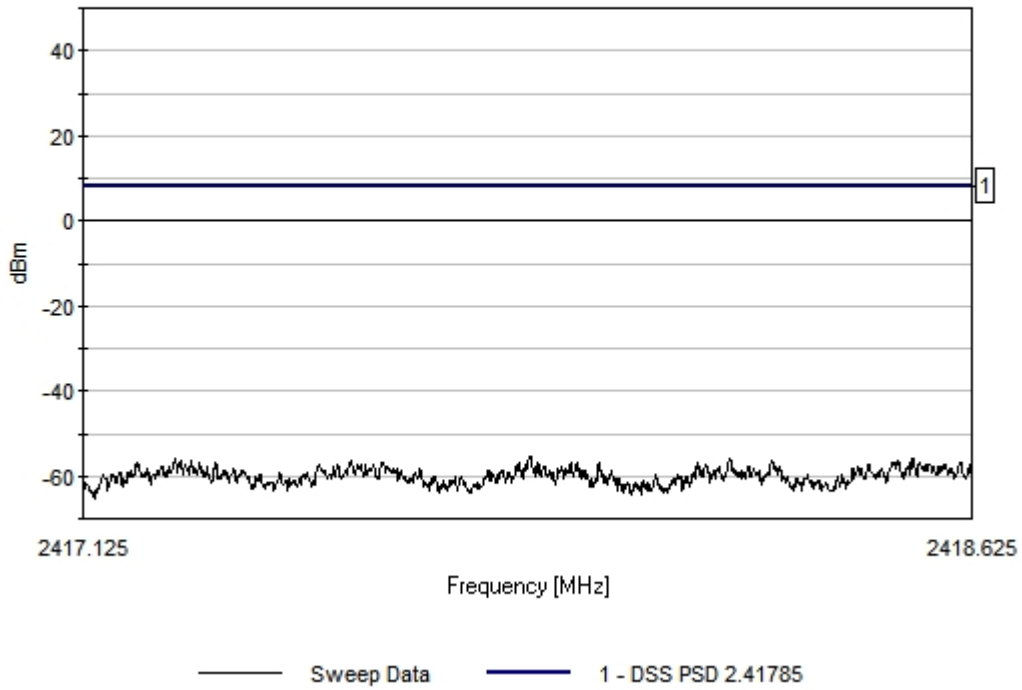

## PSD – Channel 11 / 2462 MHz / OFDM Mod / 6 MBS Data Rate

Test Location: EMCE Engineering •44366 S. Grimmer Blvd • Fremont, CA 94538 • 510-490-4307

Customer:	<b>Socket Communications, Inc.</b>	Date:	1/15/2008
Specification:	<b>2467 DSS PSD Channel 11 OFDM</b>	Time:	3:44:36 PM
Work Order #:	<b>2758</b>	Sequence#:	5
Test Type:	<b>Conducted Emissions</b>	Tested By:	Bob Cole
Equipment:	<b>CF WLAN</b>		N/A
Manufacturer:	SocketCommunications		
Model:	Go WiFi! P300-EXT		
S/N:			

**Test Equipment:**

Function	S/N	Calibration Date	Cal Due Date	Asset #
----------	-----	------------------	--------------	---------

**Equipment Under Test (\* = EUT):**

Function	Manufacturer	Model #	S/N
CF WLAN*	SocketCommunications	Go WiFi! P300-EXT	

**Support Devices:**

Function	Manufacturer	Model #	S/N
----------	--------------	---------	-----

**Test Conditions / Notes:**

2462 MHz RBW = 3 kHz VBW = 10 kHz Sweep Time = 500 sec Data Rate = 6 MBS
--

**Transducer Legend:**

T1=dBuV - dBm conversion
--------------------------

**Measurement Data:** Reading listed by margin. Test Lead: Antenna

#	Freq MHz	Rdng dBuV	T1 dB				Dist Table	Corr dBm	Spec dBm	Margin dB	Polar Ant
1	2466.977M	88.4	-107.0				+0.0	-18.6	8.0	-26.6	Anten
2	2468.243M	88.0	-107.0				+0.0	-19.0	8.0	-27.0	Anten
3	2466.954M	87.7	-107.0				+0.0	-19.3	8.0	-27.3	Anten
4	2468.185M	87.6	-107.0				+0.0	-19.4	8.0	-27.4	Anten
5	2467.266M	87.3	-107.0				+0.0	-19.7	8.0	-27.7	Anten
6	2467.882M	87.2	-107.0				+0.0	-19.8	8.0	-27.8	Anten
7	2467.600M	87.1	-107.0				+0.0	-19.9	8.0	-27.9	Anten
8	2467.315M	86.6	-107.0				+0.0	-20.4	8.0	-28.4	Anten
9	2467.248M	86.3	-107.0				+0.0	-20.7	8.0	-28.7	Anten
10	2466.919M	86.0	-107.0				+0.0	-21.0	8.0	-29.0	Anten

EMCE Engineering Date: 1/15/2008 Time: 3:44:36 PM SocketMobile, Inc. WO#: 2721  
2466.875DSS PSD Channel 11 OFDM Test Lead: Antenna N/A Sequence#: 5

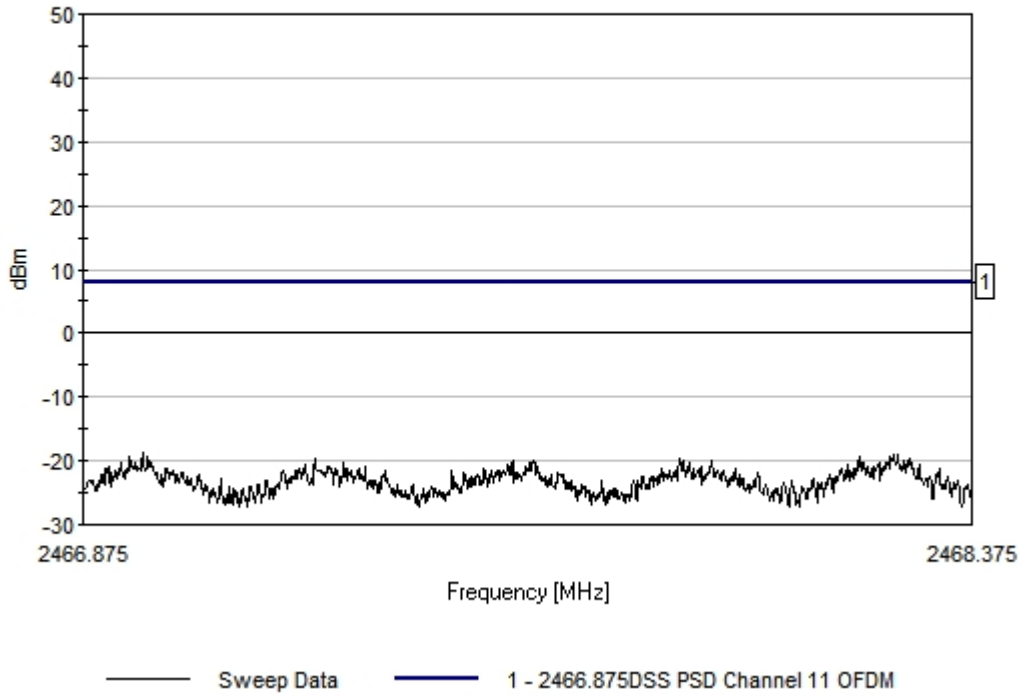



## 6 dB Bandwidth

**6 dB Bandwidth [CFR 47 15.247 (a)(1)(ii) and RSS-210 6.2.2(o)]**

<b>EUT</b>	<b>GO WI-FI! P300-EXT</b>
<b>Test setup</b>	A (conducted)
<b>Temp, Humidity, Air Pressure</b>	63° F, 30.39
<b>Date of Measurement</b>	1/23/08
<b>Measured by</b>	Bob Cole
<b>Result</b>	PASSED

### Limits and Results

#### 6 dB BANDWIDTH

EUT Channel	Limit (MHz)	Test results (MHz)
2412 OFDM 6 MB/S	>/= .500	PASS
2437 OFDM 6 MB/S	>/= .500	PASS
2467 OFDM 6 MB/S	>/= .500	PASS

## Screen Shots

### 6 dB BW Channel 1, 2412 MHz / 5.5 MBS CCK Modulation

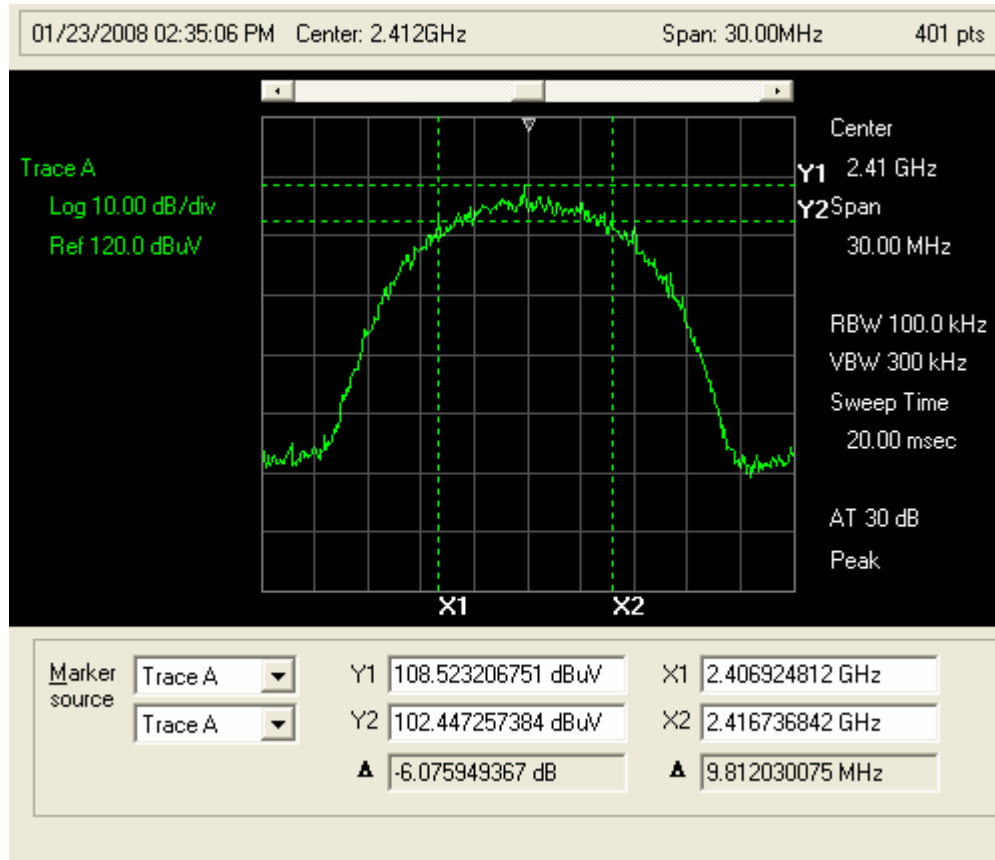

### 6 dB BW 2412 MHz / 6 Mbit OFDM Modulation

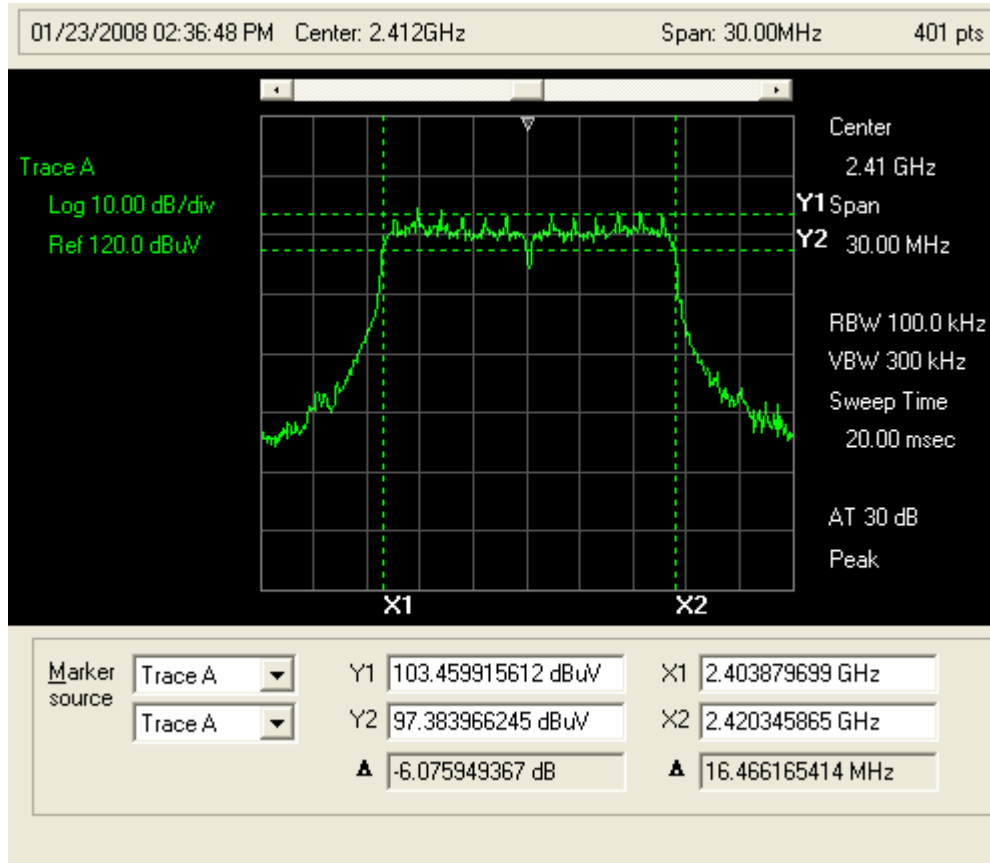

### 6 dB BW Channel 6, 2437 MHz / 5.5 MBS / CCK Modulation

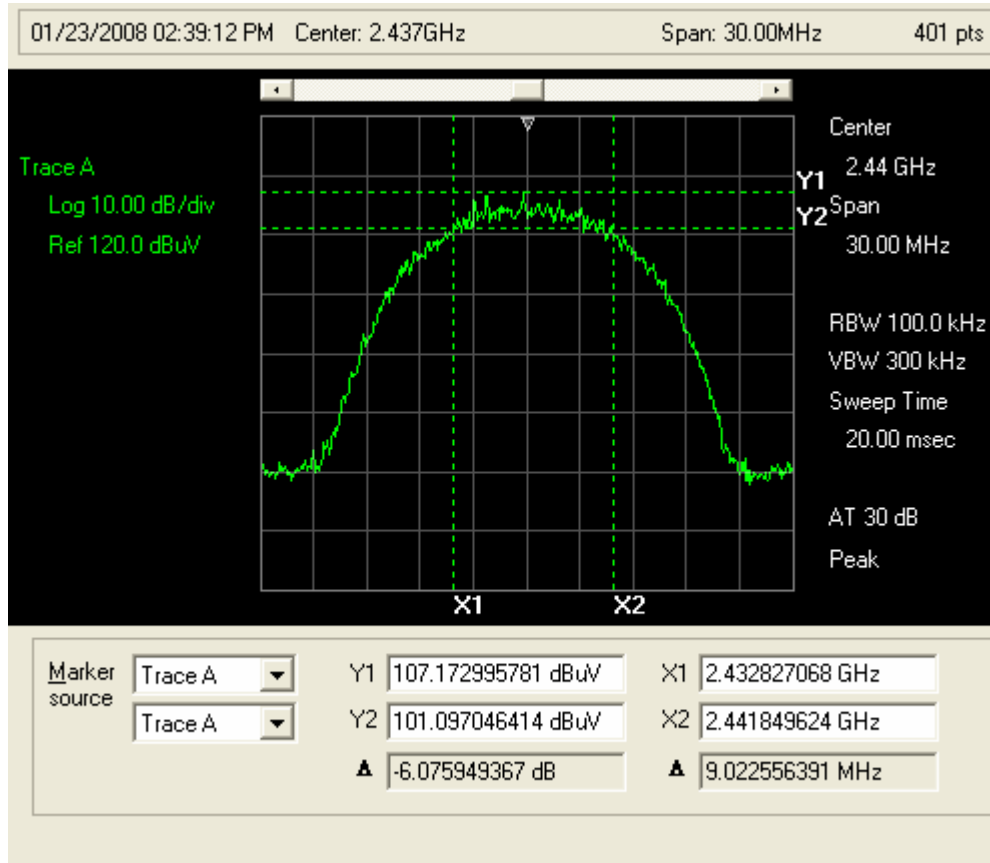

### 6 dB BW Channel 6, 2437 MHz / 6 MBS / OFDM Modulation

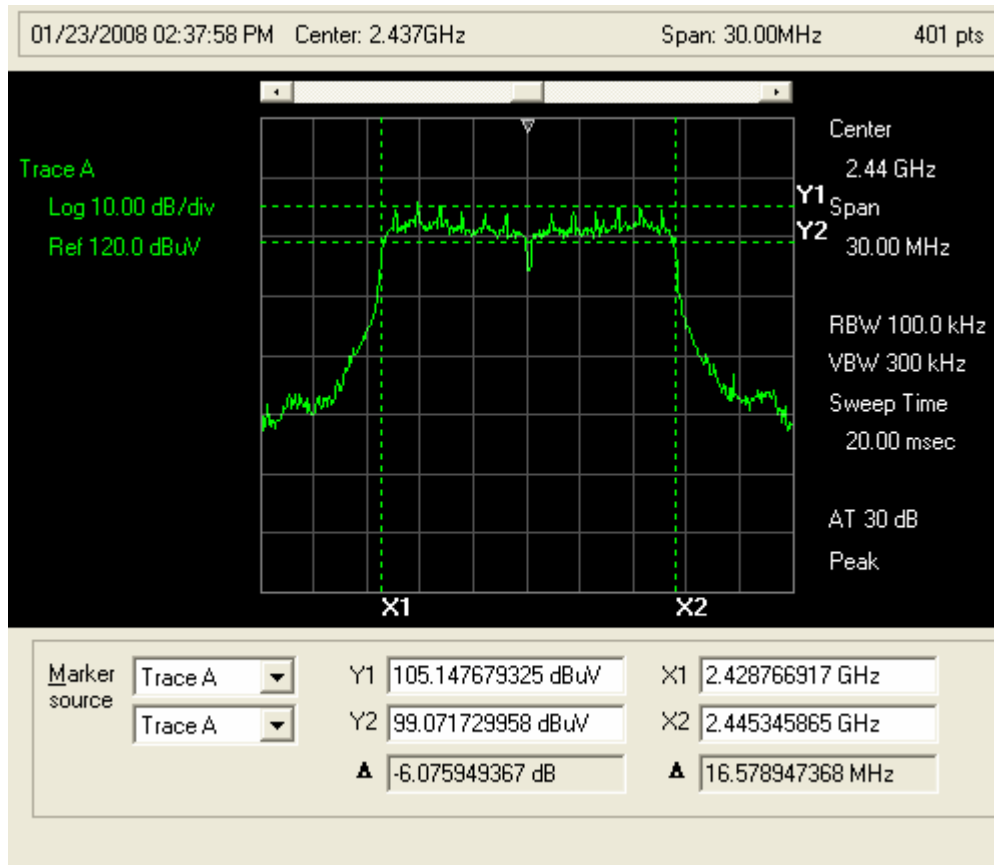

### 6 dB BW Channel 11, 2462 MHz / 5.5 MBS / CCK Modulation

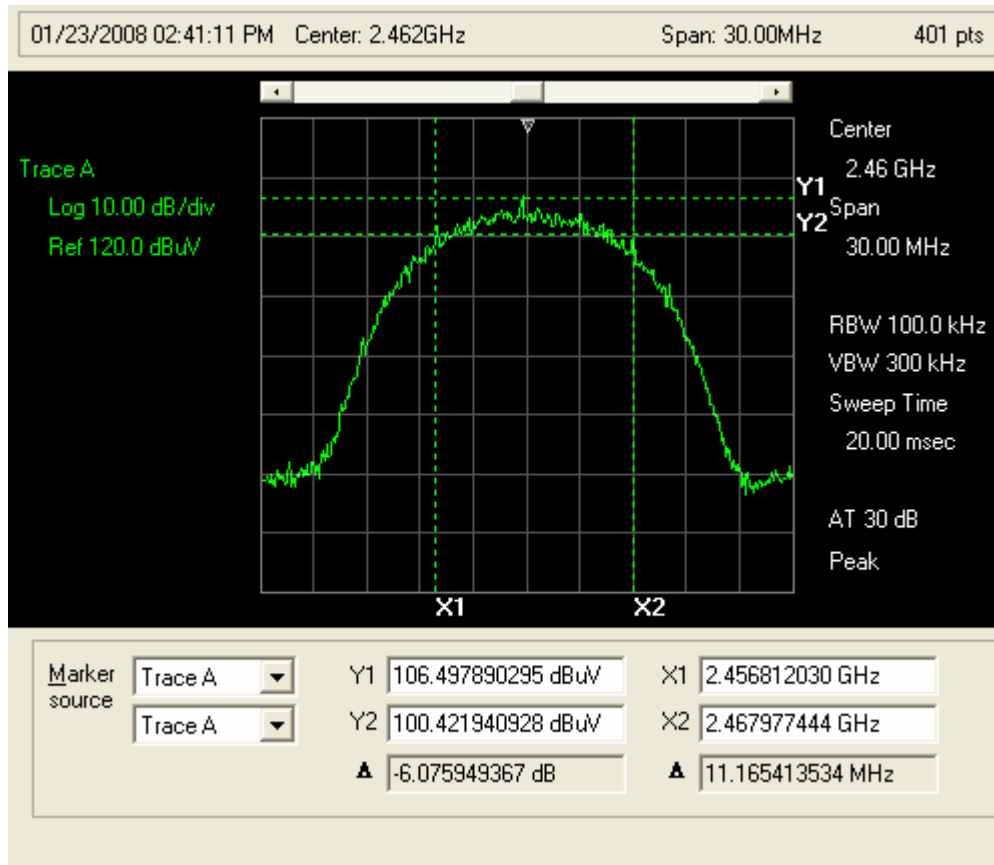

**6dB BW Channel 11, 2462 MHz / 6 MBS / OFDM Modulation**

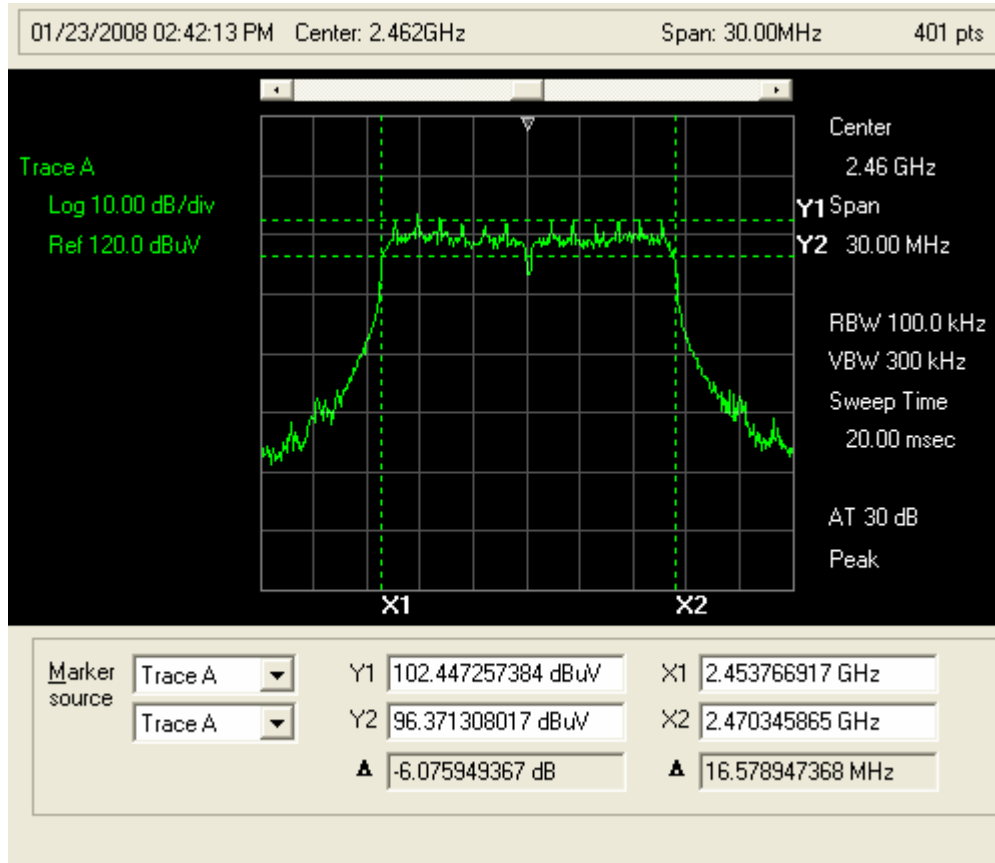

## BANEDGE MEASUREMENTS

### FCC ID: LUB-P300-EXTCF-1 Bandedge Measurement [Channel 1 / 2412 MHz CCK / 5.5 MBS - AVERAGE]

#### Channel 1 Average Power [Radiated]

Test Location: EMCE Engineering •44366 S. Grimmer Blvd • Fremont, CA 94538 • 510-490-4307

Customer: **Socket Communications, Inc.**

Specification: **FCC 2412 MHz AVE**

Work Order #: **2758**

Date: 1/22/2008

Test Type: **Radiated Scan**

Time: 11:50:03 AM

Equipment: **SD WLAN**

Sequence#: 4

Manufacturer: **SocketCommunications**

Tested By: **Bob Cole**

Model: **SDIO WLAN**

S/N:

**Test Equipment:**

Function	S/N	Calibration Date	Cal Due Date	Asset #
----------	-----	------------------	--------------	---------

**Equipment Under Test (\* = EUT):**

Function	Manufacturer	Model #	S/N
SD WLAN*	SocketCommunications	SDIO WLAN	

**Support Devices:**

Function	Manufacturer	Model #	S/N
PDA (Host)	Dell	C22	

**Test Conditions / Notes:**

2412 MHz 1 MHz RBW/ 10 Hz VBW 5.5 MBS CCK
---

**Transducer Legend:**

T1=84125 RF Amps	T2=A.H. SAS-200/571 Horn 1 meter
T3=cable1 18 GHz test	

**Measurement Data:** Reading listed by margin. Test Distance: 3 Meters

#	Freq MHz	Rdng dBµV	T1 dB	T2 dB	T3 dB	Dist dB	Table	Corr dBµV/m	Spec dBµV/m	Margin dB	Polar Ant
1	2411.068M	105.3	+54.8	+29.2	+8.8	+0.0		88.5			



EMCE Engineering Date: 1/22/2008 Time: 11:50:03 AM Socket Mobile, Inc. WO#: 2758  
FCC 2412 MHz AVE Test Distance: 3 Meters Sequence#: 4

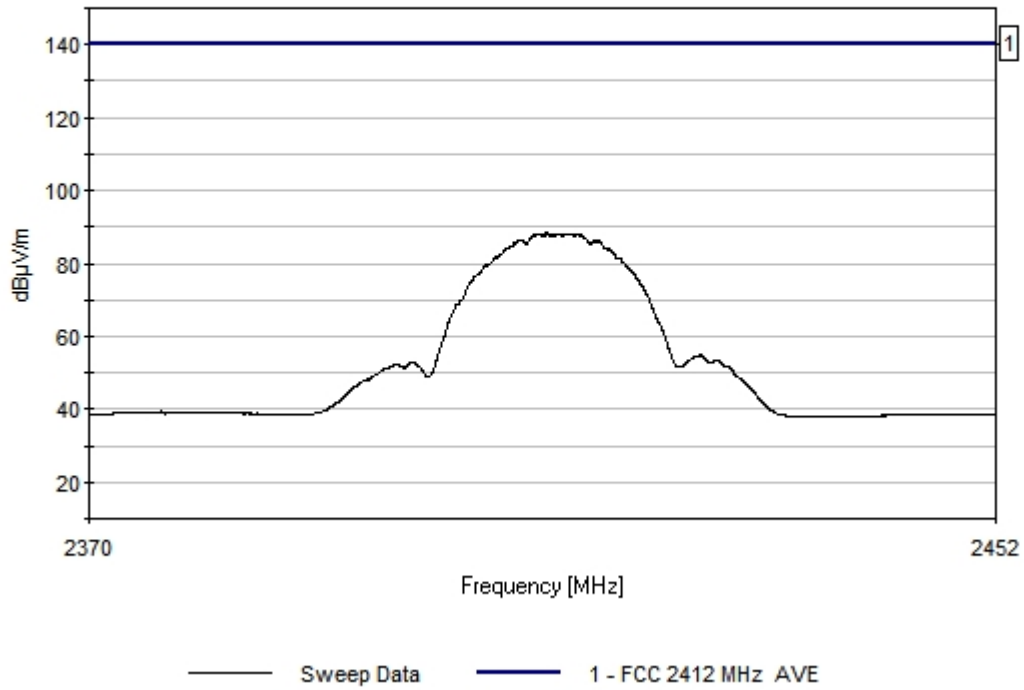

**Bandedge Measurement [Average]**

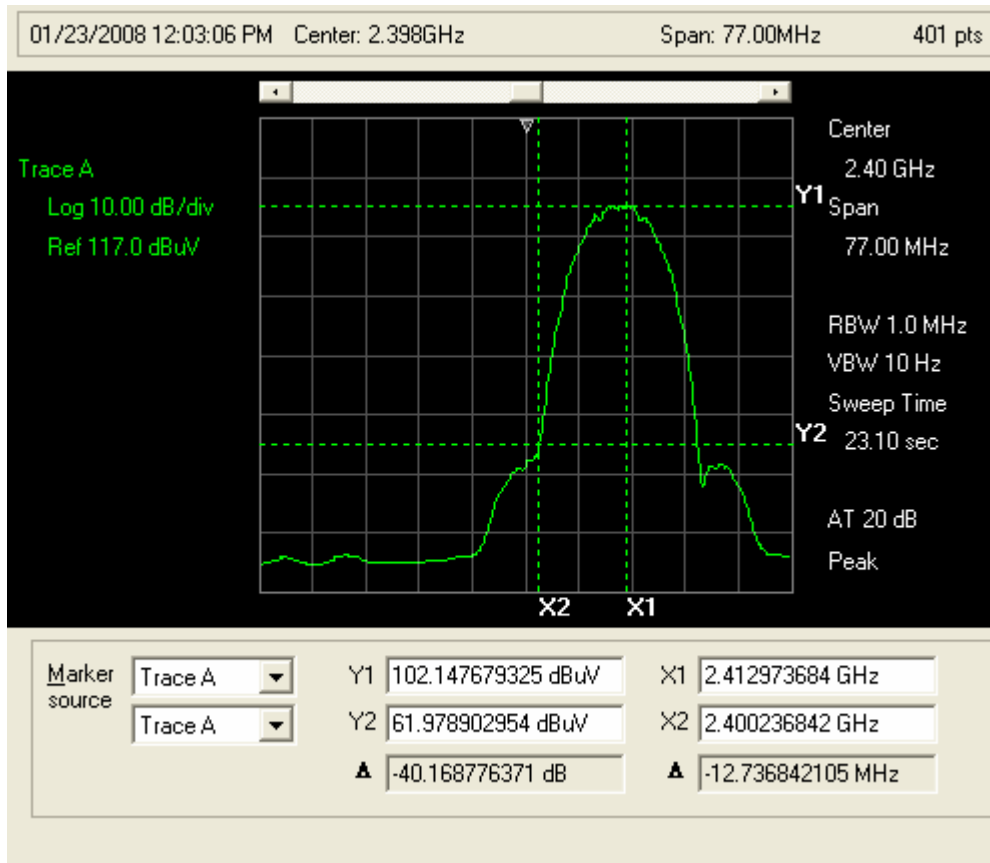

Bandedge Calculation:

Radiated Amplitude – Distance Factor (1 Meter) – Conducted Delta = Bandedge Amplitude

$$88.5 - 40.17 = 48.33 \text{ dBuV}$$

$$48.33 < 54 \text{ dB Limit}$$

**PASS**

**FCC ID: LUB-P300-EXTCF-1**  
**Bandedge Measurement**  
**[Channel 1 / 2412 MHz OFDM / 6 MBS - AVERAGE]**

**Channel 1 Average Power [Radiated]**

Test Location: EMCE Engineering •44366 S. Grimmer Blvd • Fremont, CA 94538 • 510-490-4307

Customer: **Socket Communications, Inc.**  
 Specification: **FCC 2412 MHz AVE**  
 Work Order #: **2758** Date: 1/22/2008  
 Test Type: **Radiated Scan** Time: 11:46:27 AM  
 Equipment: **SD WLAN** Sequence#: 3  
 Manufacturer: **SocketCommunications** Tested By: **Bob Cole**  
 Model: **SDIO WLAN**  
 S/N:

**Test Equipment:**

Function	S/N	Calibration Date	Cal Due Date	Asset #
----------	-----	------------------	--------------	---------

**Equipment Under Test (\* = EUT):**

Function	Manufacturer	Model #	S/N
SD WLAN*	SocketCommunications	SDIO WLAN	

**Support Devices:**

Function	Manufacturer	Model #	S/N
PDA (Host)	Dell	C22	

**Test Conditions / Notes:**

2412 MHz 1 MHz RBW/ 10 Hz VBW 6 MBS OFDM
--

**Transducer Legend:**

T1=84125 RF Amps	T2=A.H. SAS-200/571 Horn 1 meter
T3=cable1 18 GHz test	

**Measurement Data:** Reading listed by margin. Test Distance: 3 Meters

#	Freq MHz	Rdng dBµV	T1 dB	T2 dB	T3 dB	Dist dB	Corr dBµV/m	Spec dBµV/m	Margin dB	Polar Ant
1	2405.164M	101.9	+54.8	+29.2	+8.8	+0.0	85.1			

EMCE Engineering Date: 1/22/2008 Time: 11:46:27 AM Socket Mobile, Inc. WO#: 2758  
FCC 2412 MHz AVE Test Distance: 3 Meters Sequence#: 3

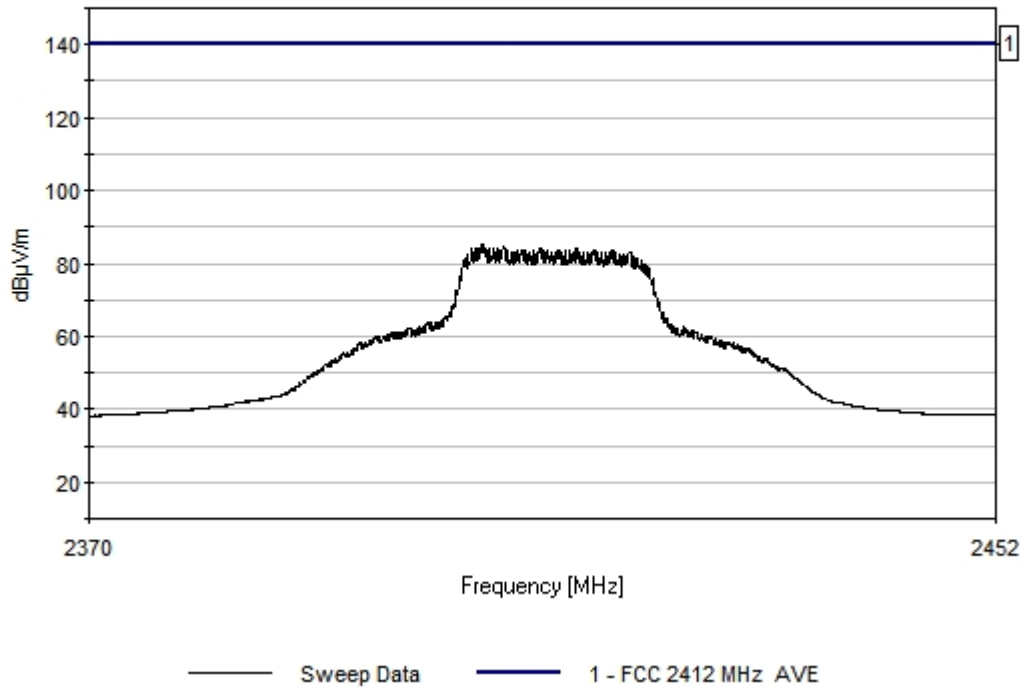

**Bandedge Measurement [Average]**

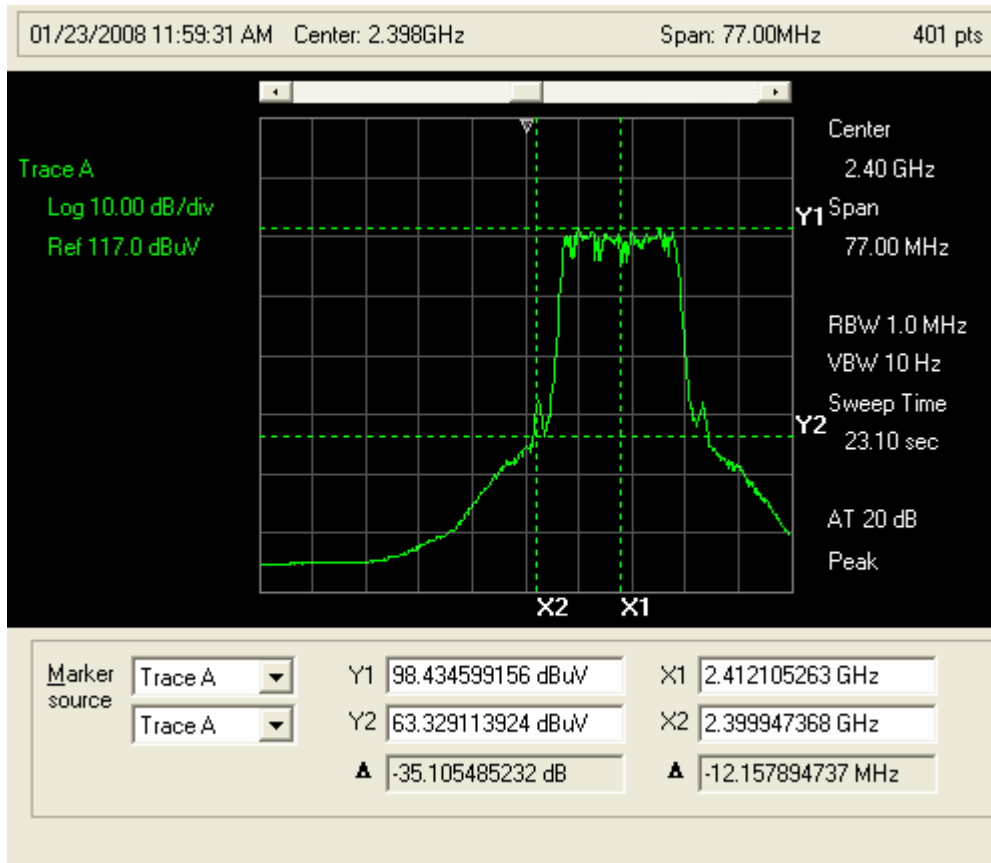

Bandedge Calculation:

Radiated Amplitude – Distance Factor (1 Meter) – Conducted Delta = Bandedge Amplitude

$$85.1 - 35.1 = 50.00 \text{ dBuV}$$

$$50.00 < 54 \text{ dB Limit}$$

**PASS**

**FCC ID: LUB-P300-EXTCF-1**  
**Bandedge Measurement**  
**[Channel 11 / 2462 MHz CCK / 1 MBS - AVERAGE]**

**Channel 11 Average Power [Radiated]**

Test Location: EMCE Engineering •44366 S. Grimmer Blvd • Fremont, CA 94538 • 510-490-4307

Customer: **Socket Communications, Inc.**

Specification: **FCC 2462 MHz AVE**

Work Order #: **2758**

Date: 1/22/2008

Test Type: **Radiated Scan**

Time: 12:01:46 PM

Equipment: **SD WLAN**

Sequence#: 8

Manufacturer: **SocketCommunications**

Tested By: **Bob Cole**

Model: **SDIO WLAN**

S/N:

**Test Equipment:**

Function	S/N	Calibration Date	Cal Due Date	Asset #
----------	-----	------------------	--------------	---------

**Equipment Under Test (\* = EUT):**

Function	Manufacturer	Model #	S/N
SD WLAN*	SocketCommunications	SDIO WLAN	

**Support Devices:**

Function	Manufacturer	Model #	S/N
PDA (Host)	Dell	C22	

**Test Conditions / Notes:**

2462 MHz 1 MHz RBW/ VBW 5.5 MBS CCK
-------------------------------------

**Transducer Legend:**

T1=84125 RF Amps	T2=A.H. SAS-200/571 Horn 1 meter
T3=cable1 18 GHz test	

**Measurement Data:** Reading listed by margin. Test Distance: 3 Meters

#	Freq MHz	Rdng dBμV	T1 dB	T2 dB	T3 dB	Dist dB	Corr dB	Spec dBμV/m	Margin dB	Polar Ant
1	2463.802M	106.9	+54.9	+29.2	+8.9	+0.0	90.1			

EMCE Engineering Date: 1/22/2008 Time: 12:01:46 PM Socket Mobile, Inc. WO#: 2758  
FCC 2462 MHz AVE Test Distance: 3 Meters Sequence#: 8

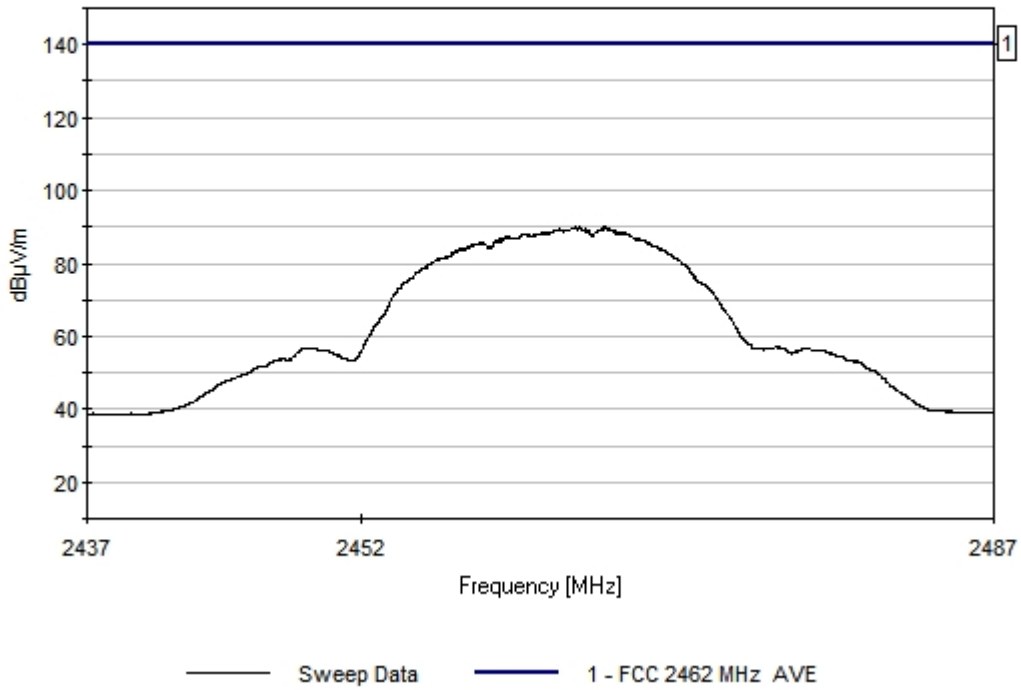

**Bandedge Measurement [Average]**

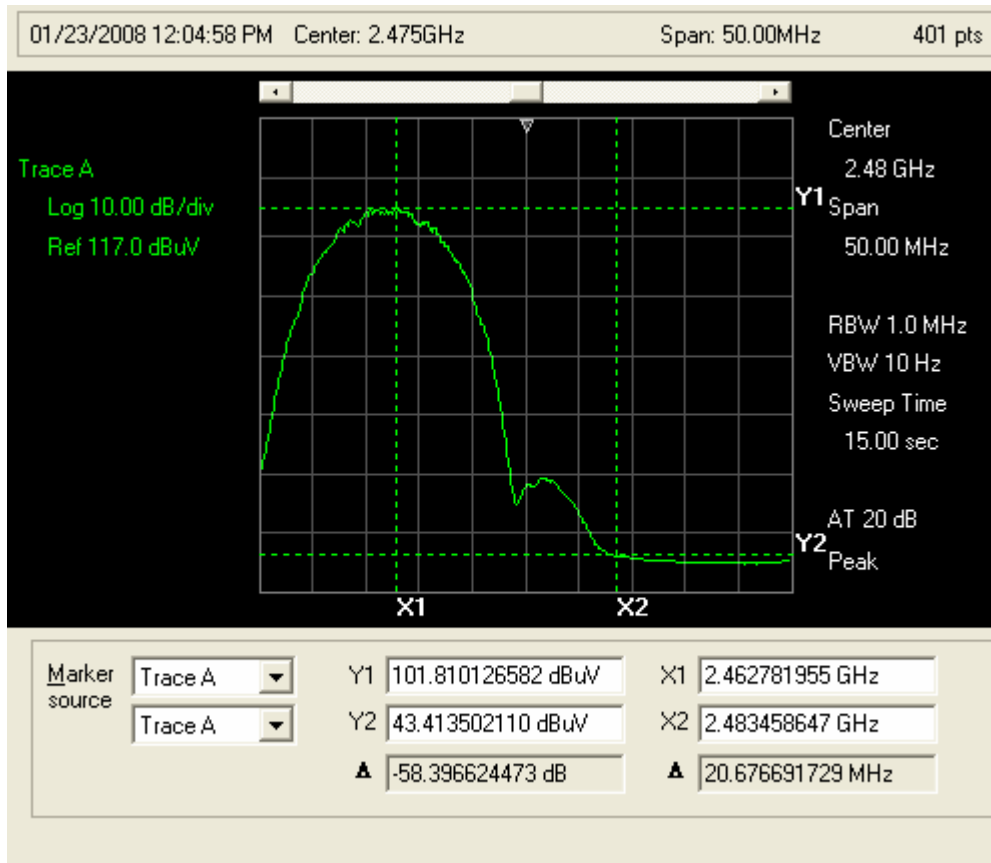

Bandedge Calculation:

Radiated Amplitude – Distance Factor (1 Meter) – Conducted Delta = Bandedge Amplitude

$$90.1 - 58.4 = 31.7 \text{ dBuV}$$

$$31.7 < 54 \text{ dB Limit}$$

**PASS**



**FCC ID: LUB-P300-EXTCF-1**  
**Bandedge Measurement**  
**[Channel 11 / 2462 MHz OFDM / 6 MBS - AVERAGE]**

**Channel 11 Average Power [Radiated]**

Test Location: EMCE Engineering •44366 S. Grimmer Blvd • Fremont, CA 94538 • 510-490-4307

Customer: **Socket Communications, Inc.**

Specification: **FCC 2462 MHz AVE**

Work Order #: **2758**

Date: 1/17/2008

Test Type: **Radiated Scan**

Time: 12:10:20 PM

Equipment: **SD WLAN**

Sequence#: 3

Manufacturer: **SocketCommunications**

Tested By: **Bob Cole**

Model: **SDIO WLAN**

S/N:

**Test Equipment:**

Function	S/N	Calibration Date	Cal Due Date	Asset #
----------	-----	------------------	--------------	---------

**Equipment Under Test (\* = EUT):**

Function	Manufacturer	Model #	S/N
SD WLAN*	SocketCommunications	SDIO WLAN	

**Support Devices:**

Function	Manufacturer	Model #	S/N
PDA (Host)	Dell	C22	

**Test Conditions / Notes:**

2462 MHz 6MBS 1 MHz RBW 10 Hz VBW
-----------------------------------

**Transducer Legend:**

T1=A.H. SAS-200/571 Horn 1 meter	T2=84125 RF Amps
T3=cable1 18 GHz test	

**Measurement Data:** Reading listed by margin. Test Distance: 3 Meters

#	Freq MHz	Rdng dBµV	T1 dB	T2 dB	T3 dB	Dist dB	Table	Corr dBµV/m	Spec dBµV/m	Margin dB	Polar Ant
1	2455.600M	110.3	+29.2	+54.9	+8.9	+0.0		93.5			

EMCE Engineering Date: 1/17/2008 Time: 12:10:20 PM Socket Mobile, Inc. WO#: 2758  
FCC 2462 MHz AVE Test Distance: 3 Meters Sequence#: 3

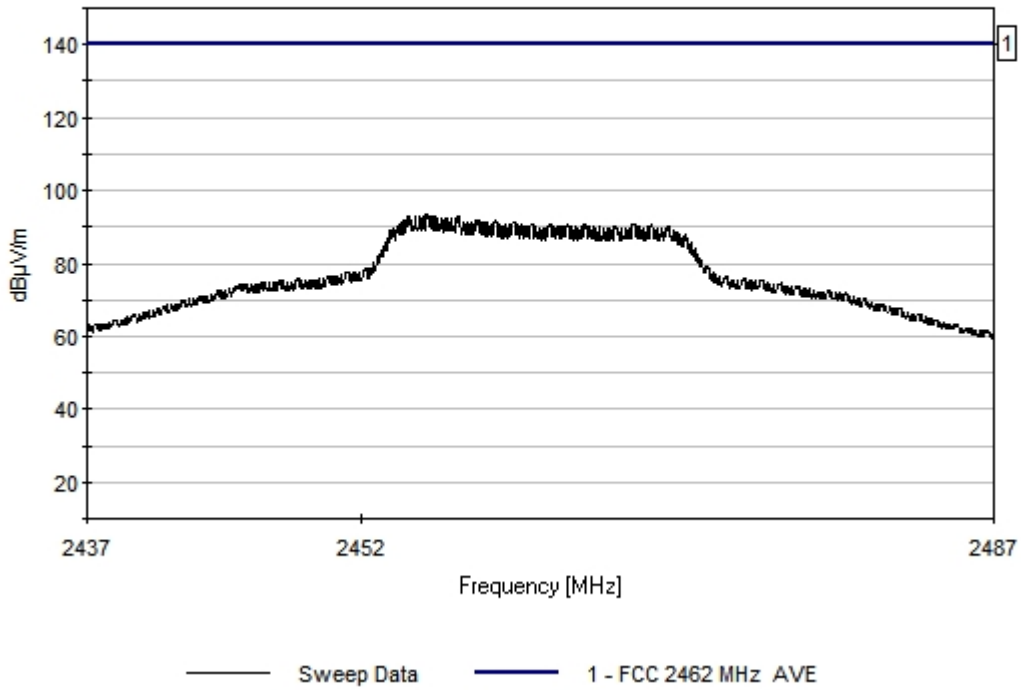

**Bandedge Measurement [Average]**

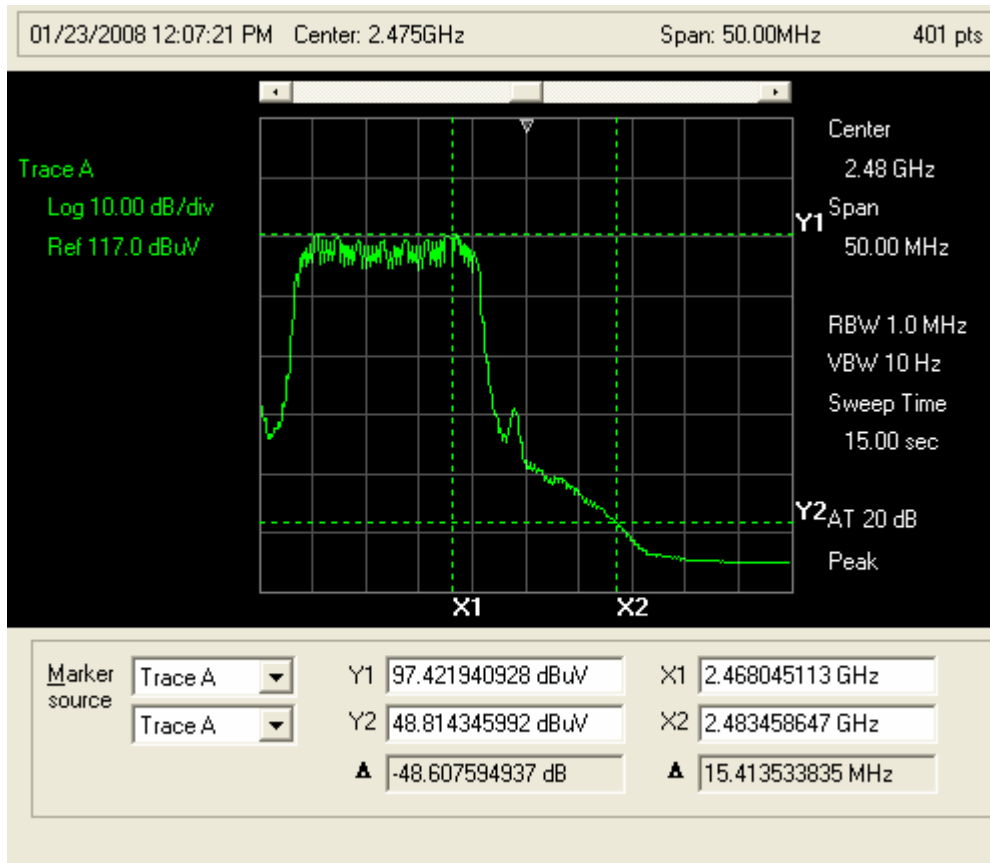

Bandedge Calculation:

Radiated Amplitude – Distance Factor (1 Meter) – Conducted Delta = Bandedge Amplitude

$$93.5 - 48.60 = 44.9 \text{ dBuV}$$

$$44.9 < 54 \text{ dB Limit}$$

**PASS**

## RESTRICTED BAND MEASUREMENTS

### Restricted Band Measurements [CFR 47, 15.247(c) and RSS-210 6.2.2(o)]

<b>EUT</b>	<b>GO WI-FI! P300-EXT</b>
<b>Test setup</b>	B (Radiated)
<b>Temp, Humidity, Air Pressure</b>	62° F, 30.45
<b>Date of Measurement</b>	1/23/08
<b>Measured by</b>	Bob Cole
<b>Result</b>	PASSED

*All Restricted Band measurements made in both horizontal and vertical polarizations, operating on Channels 1, 6, and 11 at both 802.11b (CCK) and 802.11g (OFDM) modulations with the worst case data reported.*

### Restricted Band Spurious Radiated Emissions 30 - 1000 MHz

Test Location: EMCE Engineering • 44366 S. Grimmer Blvd • Fremont, CA 94538 • 510-490-4307

Customer: **Socket Communications**  
 Specification: **FCC-Restricted Band 30-1000**  
 Work Order #: **2758** Date: 1/22/2008  
 Test Type: **Radiated Scan** Time: 1:04:03 PM  
 Equipment: **SD WLAN** Sequence#: 1  
 Manufacturer: Socket Communications Tested By: Bob Cole  
 Model: SDIO WLAN  
 S/N:

**Test Equipment:**

Function	S/N	Calibration Date	Cal Due Date	Asset #
----------	-----	------------------	--------------	---------

**Equipment Under Test (\* = EUT):**

Function	Manufacturer	Model #	S/N
SD WLAN*	Socket Communications	SDIO WLAN	

**Support Devices:**

Function	Manufacturer	Model #	S/N
PDA (Host)	Dell	C22	

**Test Conditions / Notes:**

2 MHz RBW/VBW, 120 kHz QPBW
-----------------------------

**Transducer Legend:**

T1=AH SAS-200/543 S/N: 199	T2=AH Log P SAS-200_510 S-N853
T3=cable5 test	T4=8447 Pre-Amp

**Measurement Data:** Reading listed by margin. Test Distance: 3 Meters

#	Freq MHz	Rdng dB $\mu$ V	T1 dB	T2 dB	T3 dB	T4 dB	Dist Table	Corr dB $\mu$ V/m	Spec dB $\mu$ V/m	Margin dB	Polar Ant
1	409.791M	55.7	+0.0	+15.5	+1.1	+26.8	+0.0	45.5	54.0	-8.5	Horiz
2	330.608M	55.9	+0.0	+13.8	+1.0	+26.8	+0.0	43.9	54.0	-10.1	Horiz

3	323.289M	47.5	+0.0	+13.6	+1.0	+26.8	+0.0	35.3	54.0	-18.7	Horiz
4	265.932M	42.3	+18.0	+0.0	+0.8	+26.7	+0.0	34.4	54.0	-19.6	Vert
5	992.743M	32.8	+0.0	+23.7	+1.6	+27.0	+0.0	31.1	54.0	-22.9	Vert
6	275.085M	36.9	+19.6	+0.0	+0.8	+26.7	+0.0	30.6	54.0	-23.4	Horiz
7	994.537M	32.3	+0.0	+23.7	+1.6	+27.0	+0.0	30.6	54.0	-23.4	Vert
8	984.392M	32.3	+0.0	+23.5	+1.7	+27.0	+0.0	30.5	54.0	-23.5	Vert
9	324.620M	42.4	+0.0	+13.6	+1.0	+26.8	+0.0	30.2	54.0	-23.8	Vert
10	985.151M	31.9	+0.0	+23.5	+1.7	+27.0	+0.0	30.1	54.0	-23.9	Vert

EMCE Engineering Date: 1/22/2008 Time: 1:04:03 PM Socket Communications WO#: 2758  
FCC-Restricted Band 30-1000 Test Distance: 3 Meters Sequence#: 1

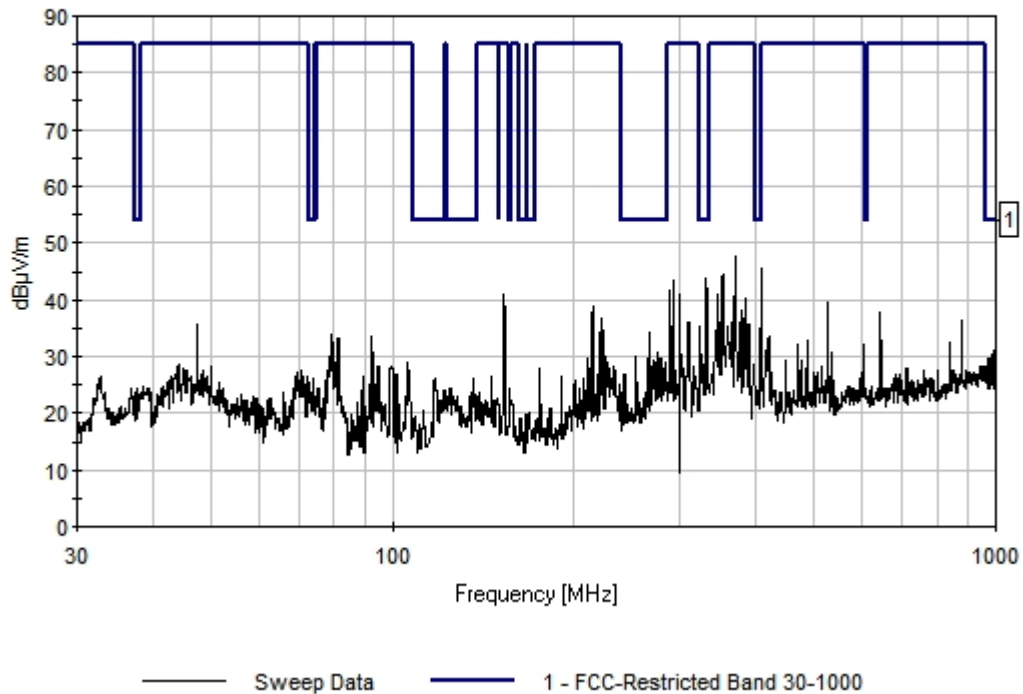

**Restricted Band Spurious Radiated Emissions**  
**1000 - 2400 MHz**  
**Channel 1 / 2412 MHz / CCK AVE**

Test Location: EMCE Engineering •44366 S. Grimmer Blvd • Fremont, CA 94538 • 510-490-4307

Customer: **Socket Mobile, Inc.**  
 Specification: **FCC Peak Restricted Band 1000-2400**  
 Work Order #: **2758** Date: 1/22/2008  
 Test Type: **Radiated Scan** Time: 2:38:50 PM  
 Equipment: **SD WLAN** Sequence#: 17  
 Manufacturer: SocketMobile Tested By: Bob Cole  
 Model: SDIO WLAN  
 S/N:

**Test Equipment:**

Function	S/N	Calibration Date	Cal Due Date	Asset #
----------	-----	------------------	--------------	---------

**Equipment Under Test (\* = EUT):**

Function	Manufacturer	Model #	S/N
SD WLAN*	SocketMobile	SDIO WLAN	

**Support Devices:**

Function	Manufacturer	Model #	S/N
PDA (Host)	Dell	C22	

**Test Conditions / Notes:**

2412 MHz 1 MHz RBW/ 10 Hz VBW 5.5 MBS CCK
---

**Transducer Legend:**

T1=84125 RF Amps	T2=A.H. SAS-200/571 Horn 1 meter
T3=cable1 18 GHz test	

**Measurement Data:** Reading listed by margin. Test Distance: 3 Meters

#	Freq MHz	Rdng dBµV	T1 dB	T2 dB	T3 dB	dB	Dist Table	Corr dBµV/m	Spec dBµV/m	Margin dB	Polar Ant
1	1000.339M	72.1	+54.8	+23.5	+7.0		+0.0	47.8	54.0	-6.2	Vert
2	1016.262M	71.1	+54.8	+23.5	+7.0		+0.0	46.8	54.0	-7.2	Vert
3	1033.202M	69.2	+54.8	+23.5	+7.0		+0.0	44.9	54.0	-9.1	Vert
4	1500.317M	66.8	+54.9	+24.5	+7.6		+0.0	44.0	54.0	-10.0	Vert
5	1099.607M	66.7	+54.8	+23.6	+7.1		+0.0	42.6	54.0	-11.4	Vert
6	1045.060M	66.4	+54.8	+23.6	+7.1		+0.0	42.3	54.0	-11.7	Vert
7	1021.006M	66.5	+54.8	+23.5	+7.0		+0.0	42.2	54.0	-11.8	Vert
8	2398.177M	76.7	+54.8	+29.2	+8.8		+0.0	59.9	85.0	-25.1	Vert
9	1299.838M	73.6	+54.9	+24.0	+7.4		+0.0	50.1	85.0	-34.9	Vert
10	1803.435M	67.5	+55.0	+26.0	+7.9		+0.0	46.4	85.0	-38.6	Vert

EMCE Engineering Date: 1/22/2008 Time: 2:38:50 PM Socket Mobile, Inc. WO#: 2758  
FCC Peak Restricted Band 1000-2400 Test Distance: 3 Meters Sequence#: 17

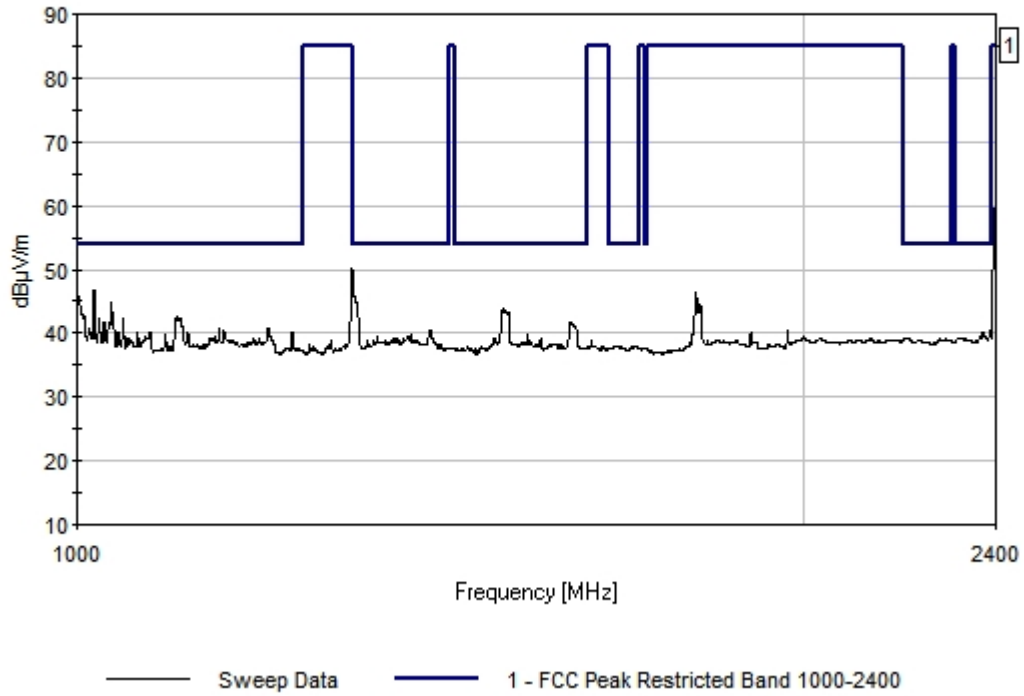

## Restricted Band Spurious Radiated Emissions 1000 - 2400 MHz

### Channel 1 / 2412 MHz / OFDM AVE

Test Location: EMCE Engineering • 44366 S. Grimmer Blvd • Fremont, CA 94538 • 510-490-4307

Customer:	<b>Socket Mobile, Inc.</b>	Date:	1/22/2008
Specification:	<b>FCC Peak Restricted Band 1000-2400</b>	Time:	2:34:29 PM
Work Order #:	<b>2758</b>	Sequence#:	16
Test Type:	<b>Radiated Scan</b>	Tested By:	Bob Cole
Equipment:	<b>SD WLAN</b>		
Manufacturer:	SocketMobile		
Model:	SDIO WLAN		
S/N:			

**Test Equipment:**

Function	S/N	Calibration Date	Cal Due Date	Asset #
----------	-----	------------------	--------------	---------

**Equipment Under Test (\* = EUT):**

Function	Manufacturer	Model #	S/N
SD WLAN*	SocketMobile	SDIO WLAN	

**Support Devices:**

Function	Manufacturer	Model #	S/N
PDA (Host)	Dell	C22	

**Test Conditions / Notes:**

2412 MHz 1 MHz RBW/ 10 Hz VBW 6 MBS OFDM
--

**Transducer Legend:**

T1=84125 RF Amps	T2=A.H. SAS-200/571 Horn 1 meter
T3=cable1 18 GHz test	

**Measurement Data:**      Reading listed by margin.      Test Distance: 3 Meters

#	Freq MHz	Rdng dBµV	T1 dB	T2 dB	T3 dB	dB	Dist Table	Corr dBµV/m	Spec dBµV/m	Margin dB	Polar Ant
1	1000.339M	72.3	+54.8	+23.5	+7.0		+0.0	48.0	54.0	-6.0	Vert
2	1016.262M	71.1	+54.8	+23.5	+7.0		+0.0	46.8	54.0	-7.2	Vert
3	1033.202M	69.0	+54.8	+23.5	+7.0		+0.0	44.7	54.0	-9.3	Vert
4	1499.864M	67.0	+54.9	+24.5	+7.6		+0.0	44.2	54.0	-9.8	Vert
5	1099.607M	67.0	+54.8	+23.6	+7.1		+0.0	42.9	54.0	-11.1	Vert
6	1045.060M	66.5	+54.8	+23.6	+7.1		+0.0	42.4	54.0	-11.6	Vert
7	1021.006M	66.7	+54.8	+23.5	+7.0		+0.0	42.4	54.0	-11.6	Vert
8	2399.393M	79.8	+54.8	+29.2	+8.8		+0.0	63.0	85.0	-22.0	Vert
9	1299.838M	73.7	+54.9	+24.0	+7.4		+0.0	50.2	85.0	-34.8	Vert



10	1806.473M	65.6	+55.0	+26.1	+7.9	+0.0	44.6	85.0	-40.4	Vert
----	-----------	------	-------	-------	------	------	------	------	-------	------

EMCE Engineering Date: 1/22/2008 Time: 2:34:29 PM Socket Mobile, Inc. WO#: 2758  
FCC Peak Restricted Band 1000-2400 Test Distance: 3 Meters Sequence#: 16

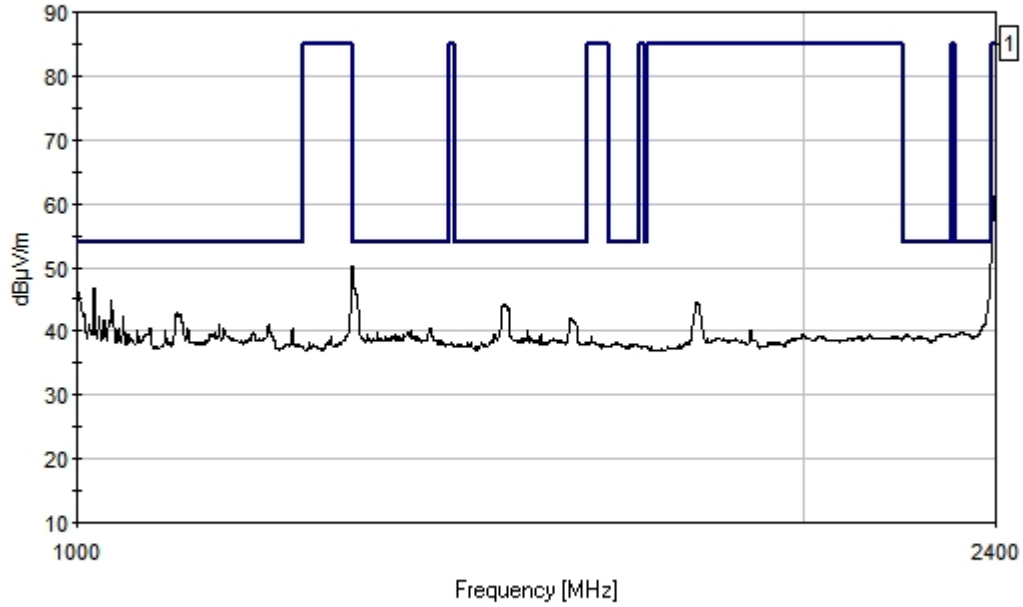

— Sweep Data      — 1 - FCC Peak Restricted Band 1000-2400

## Restricted Band Spurious Radiated Emissions 1000 - 2400 MHz

### Channel 6 / 2437 MHz / CCK Average

Test Location: EMCE Engineering • 44366 S. Grimmer Blvd • Fremont, CA 94538 • 510-490-4307

Customer: **Socket Communications, Inc.**  
 Specification: **FCC Average Limits 1000-2400**  
 Work Order #: **2758** Date: 1/22/2008  
 Test Type: **Radiated Scan** Time: 2:45:18 PM  
 Equipment: **SD WLAN** Sequence#: 19  
 Manufacturer: Socket Communications Tested By: Bob Cole  
 Model: SDIO WLAN  
 S/N:

**Test Equipment:**

Function	S/N	Calibration Date	Cal Due Date	Asset #
----------	-----	------------------	--------------	---------

**Equipment Under Test (\* = EUT):**

Function	Manufacturer	Model #	S/N
SD WLAN*	Socket Communications	SDIO WLAN	

**Support Devices:**

Function	Manufacturer	Model #	S/N
PDA (Host)	Dell	C22	

**Test Conditions / Notes:**

2437 MHz 1 MHz RBW/ 10 Hz VBW 5.5 MBS CCK
---

**Transducer Legend:**

T1=84125 RF Amps	T2=A.H. SAS-200/571 Horn 1 meter
T3=cable1 18 GHz test	

**Measurement Data:**

Reading listed by margin.

Test Distance: 3 Meters

#	Freq MHz	Rdng dBµV	Reading listed by margin.			dB	Test Distance: 3 Meters				
			T1 dB	T2 dB	T3 dB		Dist Table	Corr dBµV/m	Spec dBµV/m	Margin dB	Polar Ant
1	1848.390M	71.5	+55.0	+26.6	+7.9	+0.0	51.0	54.0	-3.0	Vert	
2	1840.493M	70.0	+55.0	+26.5	+7.9	+0.0	49.4	54.0	-4.6	Vert	
3	1299.838M	68.7	+54.9	+24.0	+7.4	+0.0	45.2	54.0	-8.8	Vert	
4	1000.339M	68.4	+54.8	+23.5	+7.0	+0.0	44.1	54.0	-9.9	Vert	
5	1016.262M	67.3	+54.8	+23.5	+7.0	+0.0	43.0	54.0	-11.0	Vert	
6	1033.202M	65.3	+54.8	+23.5	+7.0	+0.0	41.0	54.0	-13.0	Vert	
7	1500.317M	62.4	+54.9	+24.5	+7.6	+0.0	39.6	54.0	-14.4	Vert	
8	1099.607M	62.9	+54.8	+23.6	+7.1	+0.0	38.8	54.0	-15.2	Vert	
9	1021.344M	63.0	+54.8	+23.5	+7.0	+0.0	38.7	54.0	-15.3	Vert	

10	1044.722M	62.8	+54.8	+23.6	+7.1	+0.0	38.7	54.0	-15.3	Vert
----	-----------	------	-------	-------	------	------	------	------	-------	------

EMCE Engineering Date: 1/22/2008 Time: 2:45:18 PM Socket Mobile, Inc. WO#: 2758  
FCC Average Limits 1000-2400 Test Distance: 3 Meters Sequence#: 19

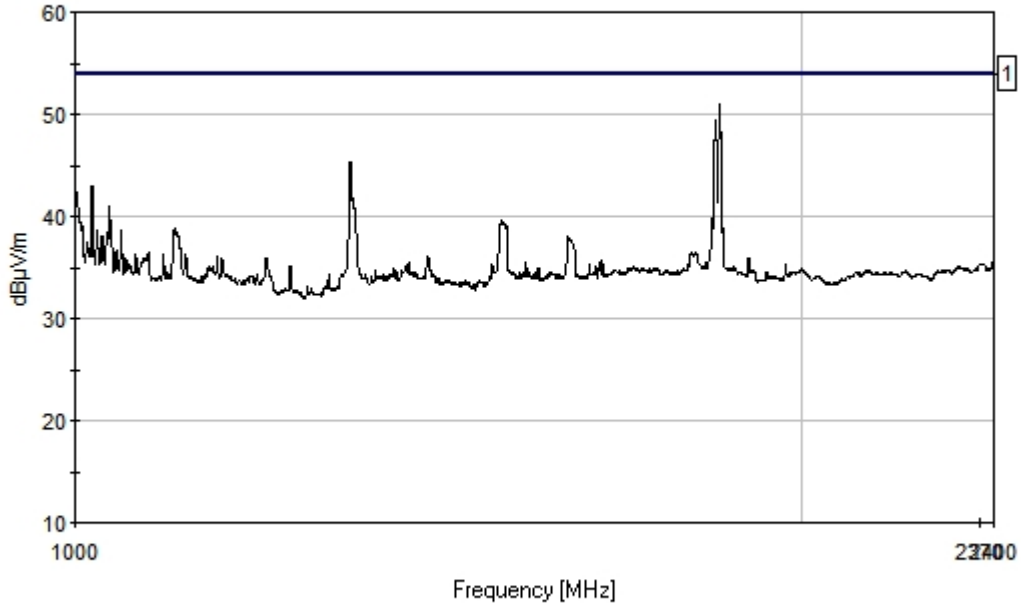

— Sweep Data      — 1 - FCC Average Limits 1000-2400

## Restricted Band Spurious Radiated Emissions 1000 - 2400 MHz

### Channel 6 / 2437 MHz / OFDM Average

Test Location: EMCE Engineering • 44366 S. Grimmer Blvd • Fremont, CA 94538 • 510-490-4307

Customer: **Socket Communications, Inc.**  
 Specification: **FCC Average Limits 1000-2400**  
 Work Order #: **2758** Date: 1/22/2008  
 Test Type: **Radiated Scan** Time: 2:48:26 PM  
 Equipment: **SD WLAN** Sequence#: 20  
 Manufacturer: Socket Communications Tested By: Bob Cole  
 Model: SDIO WLAN  
 S/N:

**Test Equipment:**

Function	S/N	Calibration Date	Cal Due Date	Asset #
----------	-----	------------------	--------------	---------

**Equipment Under Test (\* = EUT):**

Function	Manufacturer	Model #	S/N
SD WLAN*	Socket Communications	SDIO WLAN	

**Support Devices:**

Function	Manufacturer	Model #	S/N
PDA (Host)	Dell	C22	

**Test Conditions / Notes:**

2437 MHz 1 MHz RBW/ 10 Hz VBW 6 MBS OFDM
--

**Transducer Legend:**

T1=84125 RF Amps	T2=A.H. SAS-200/571 Horn 1 meter
T3=cable1 18 GHz test	

**Measurement Data:**

Reading listed by margin.

Test Distance: 3 Meters

#	Freq MHz	Rdng dBµV	Reading listed by margin.			dB	Test Distance: 3 Meters			Margin dB	Polar Ant
			T1 dB	T2 dB	T3 dB		Dist Table	Corr dBµV/m	Spec dBµV/m		
1	2399.393M	65.6	+54.8	+29.2	+8.8	+0.0	48.8	54.0	-5.2	Vert	
2	1845.353M	67.8	+55.0	+26.6	+7.9	+0.0	47.3	54.0	-6.7	Vert	
3	1299.838M	70.1	+54.9	+24.0	+7.4	+0.0	46.6	54.0	-7.4	Vert	
4	1000.339M	68.8	+54.8	+23.5	+7.0	+0.0	44.5	54.0	-9.5	Vert	
5	1016.262M	67.9	+54.8	+23.5	+7.0	+0.0	43.6	54.0	-10.4	Vert	
6	1502.586M	65.1	+54.9	+24.5	+7.6	+0.0	42.3	54.0	-11.7	Vert	
7	1033.202M	66.3	+54.8	+23.5	+7.0	+0.0	42.0	54.0	-12.0	Vert	
8	1099.607M	64.4	+54.8	+23.6	+7.1	+0.0	40.3	54.0	-13.7	Vert	
9	1045.060M	64.1	+54.8	+23.6	+7.1	+0.0	40.0	54.0	-14.0	Vert	

10	1021.006M	64.1	+54.8	+23.5	+7.0	+0.0	39.8	54.0	-14.2	Vert
----	-----------	------	-------	-------	------	------	------	------	-------	------

EMCE Engineering Date: 1/22/2008 Time: 2:48:26 PM Socket Mobile, Inc. WO#: 2758  
FCC Average Limits 1000-2400 Test Distance: 3 Meters Sequence#: 20

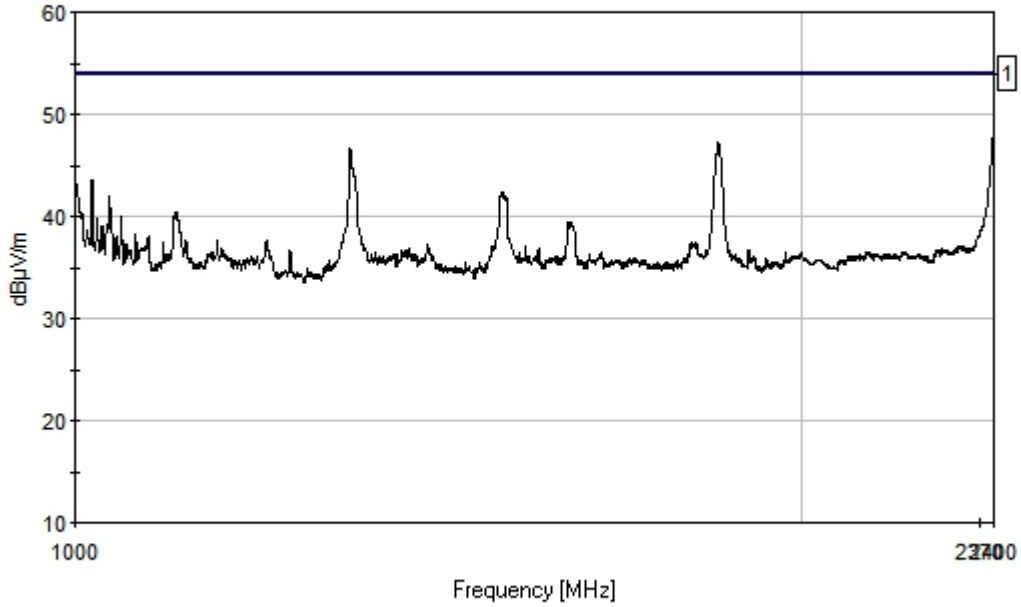

— Sweep Data      — 1 - FCC Average Limits 1000-2400

## Restricted Band Spurious Radiated Emissions 1000 - 2400 MHz

### Channel 11 / 2462 MHz / CCK AVG

Test Location: EMCE Engineering •44366 S. Grimmer Blvd • Fremont, CA 94538 • 510-490-4307

Customer: **Socket Communications, Inc.**  
 Specification: **FCC Average Limits 1000-2400**  
 Work Order #: **2758**  
 Test Type: **Radiated Scan**  
 Equipment: **SD WLAN**  
 Manufacturer: **Socket Communications**  
 Model: **SDIO WLAN**  
 S/N:

Date: 1/22/2008  
 Time: 2:55:29 PM  
 Sequence#: 22  
 Tested By: Bob Cole

**Test Equipment:**

Function	S/N	Calibration Date	Cal Due Date	Asset #
----------	-----	------------------	--------------	---------

**Equipment Under Test (\* = EUT):**

Function	Manufacturer	Model #	S/N
SD WLAN*	Socket Communications	SDIO WLAN	

**Support Devices:**

Function	Manufacturer	Model #	S/N
PDA (Host)	Dell	C22	

**Test Conditions / Notes:**

2462 MHz 1 MHz RBW/ 10 Hz VBW 5.5 MBS CCK
---

**Transducer Legend:**

T1=84125 RF Amps	T2=A.H. SAS-200/571 Horn 1 meter
T3=cable1 18 GHz test	

<b>Measurement Data:</b>		Reading listed by margin.					Test Distance: 3 Meters					
#	Freq MHz	Rdng dB $\mu$ V	T1 dB	T2 dB	T3 dB	Dist dB	Corr dB $\mu$ V/m	Spec dB $\mu$ V/m	Margin dB	Polar Ant		
1	1885.448M	71.4	+55.0	+27.1	+7.9	+0.0	51.4	54.0	-2.6	Vert		
2	1878.157M	70.7	+55.0	+27.0	+7.9	+0.0	50.6	54.0	-3.4	Vert		
3	1299.838M	67.5	+54.9	+24.0	+7.4	+0.0	44.0	54.0	-10.0	Vert		
4	1000.339M	67.2	+54.8	+23.5	+7.0	+0.0	42.9	54.0	-11.1	Vert		
5	1016.262M	66.3	+54.8	+23.5	+7.0	+0.0	42.0	54.0	-12.0	Vert		
6	1033.202M	64.4	+54.8	+23.5	+7.0	+0.0	40.1	54.0	-13.9	Vert		
7	1045.060M	62.8	+54.8	+23.6	+7.1	+0.0	38.7	54.0	-15.3	Vert		
8	1499.864M	61.3	+54.9	+24.5	+7.6	+0.0	38.5	54.0	-15.5	Vert		
9	1099.607M	62.3	+54.8	+23.6	+7.1	+0.0	38.2	54.0	-15.8	Vert		

10	1021.006M	62.1	+54.8	+23.5	+7.0	+0.0	37.8	54.0	-16.2	Vert
----	-----------	------	-------	-------	------	------	------	------	-------	------

EMCE Engineering Date: 1/22/2008 Time: 2:55:29 PM Socket Mobile, Inc. WO#: 2758  
FCC Average Limits 1000-2400 Test Distance: 3 Meters Sequence#: 22

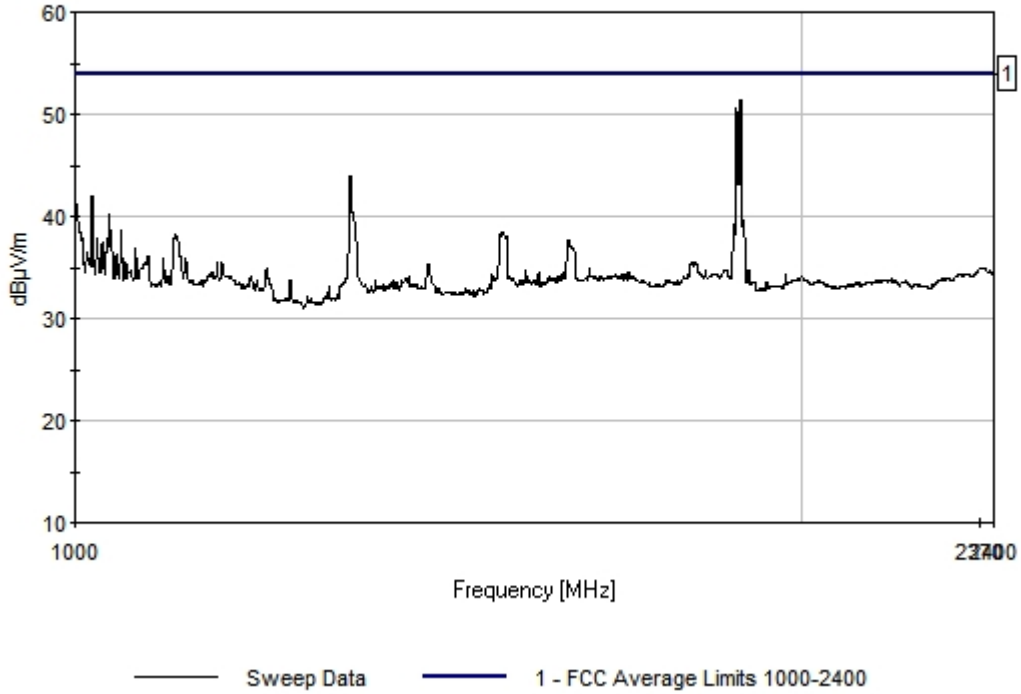

## Restricted Band Spurious Radiated Emissions 1000 - 2400 MHz

### Channel 11 / 2462 MHz / OFDM AVG

Test Location: EMCE Engineering • 44366 S. Grimmer Blvd • Fremont, CA 94538 • 510-490-4307

Customer: **Socket Communications, Inc.**  
 Specification: **FCC Average Limits 1000-2400**  
 Work Order #: **2758** Date: 1/22/2008  
 Test Type: **Radiated Scan** Time: 2:52:08 PM  
 Equipment: **SD WLAN** Sequence#: 21  
 Manufacturer: Socket Communications Tested By: Bob Cole  
 Model: SDIO WLAN  
 S/N:

**Test Equipment:**

Function	S/N	Calibration Date	Cal Due Date	Asset #
----------	-----	------------------	--------------	---------

**Equipment Under Test (\* = EUT):**

Function	Manufacturer	Model #	S/N
SD WLAN*	Socket Communications	SDIO WLAN	

**Support Devices:**

Function	Manufacturer	Model #	S/N
PDA (Host)	Dell	C22	

**Test Conditions / Notes:**

2462 MHz 1 MHz RBW/ 10 Hz VBW 6 MBS OFDM
--

**Transducer Legend:**

T1=84125 RF Amps	T2=A.H. SAS-200/571 Horn 1 meter
T3=cable1 18 GHz test	

**Measurement Data:**

Reading listed by margin.

Test Distance: 3 Meters

#	Freq MHz	Rdng dBµV	Reading listed by margin.			Dist Table	Corr dBµV/m	Spec dBµV/m	Margin dB	Polar Ant
			T1 dB	T2 dB	T3 dB					
1	1299.838M	71.1	+54.9	+24.0	+7.4	+0.0	47.6	54.0	-6.4	Vert
2	1881.802M	67.2	+55.0	+27.0	+7.9	+0.0	47.1	54.0	-6.9	Vert
3	1000.339M	69.2	+54.8	+23.5	+7.0	+0.0	44.9	54.0	-9.1	Vert
4	1016.262M	68.6	+54.8	+23.5	+7.0	+0.0	44.3	54.0	-9.7	Vert
5	1503.039M	65.3	+54.9	+24.5	+7.6	+0.0	42.5	54.0	-11.5	Vert
6	1033.202M	66.5	+54.8	+23.5	+7.0	+0.0	42.2	54.0	-11.8	Vert
7	1045.060M	64.8	+54.8	+23.6	+7.1	+0.0	40.7	54.0	-13.3	Vert
8	1100.285M	64.8	+54.8	+23.6	+7.1	+0.0	40.7	54.0	-13.3	Vert
9	1602.400M	62.3	+54.9	+24.8	+7.7	+0.0	39.9	54.0	-14.1	Vert



10	1026.088M	64.0	+54.8	+23.5	+7.0	+0.0	39.7	54.0	-14.3	Vert
----	-----------	------	-------	-------	------	------	------	------	-------	------

EMCE Engineering Date: 1/22/2008 Time: 2:52:08 PM Socket Mobile, Inc. WO#: 2758  
FCC Average Limits 1000-2400 Test Distance: 3 Meters Sequence#: 21

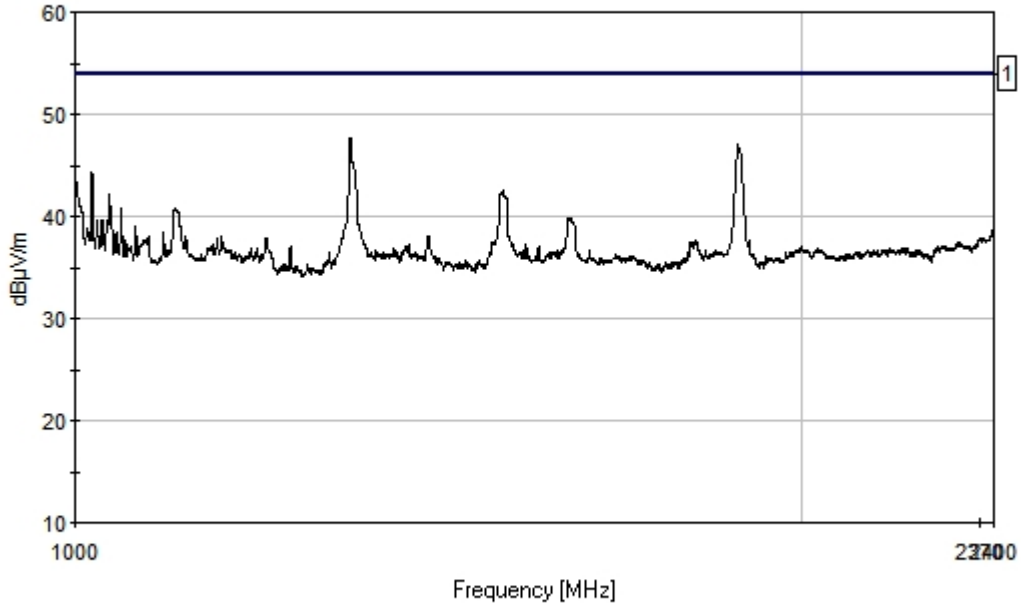

— Sweep Data      — 1 - FCC Average Limits 1000-2400

## Restricted Band Spurious Radiated Emissions 2483.5 - 18000 MHz

### Channel 1 / 2412 MHz / CCK Average

Test Location: EMCE Engineering • 44366 S. Grimmer Blvd • Fremont, CA 94538 • 510-490-4307

Customer: **Socket Communications, Inc.**  
 Specification: **FCC Rad Average Limits 2483.5 - 12750**  
 Work Order #: **2758** Date: 1/30/2008  
 Test Type: **Radiated Scan** Time: 2:59:37 PM  
 Equipment: **SD WLAN** Sequence#: 15  
 Manufacturer: Socket Communications Tested By: Bob Cole  
 Model: SDIO WLAN  
 S/N:

**Test Equipment:**

Function	S/N	Calibration Date	Cal Due Date	Asset #
----------	-----	------------------	--------------	---------

**Equipment Under Test (\* = EUT):**

Function	Manufacturer	Model #	S/N
SD WLAN*	Socket Communications	SDIO WLAN	

**Support Devices:**

Function	Manufacturer	Model #	S/N
PDA (Host)	Dell	C22	

**Test Conditions / Notes:**

2412 MHz 1 MHz RBW/ 10 Hz VBW 5.5 MBS CCK
---

**Transducer Legend:**

T1=84125 RF Amps	T2=A.H. SAS-200/571 Horn 1 meter
T3=cable1 18 GHz test	

**Measurement Data:**

Reading listed by margin.

Test Distance: 3 Meters

#	Freq MHz	Rdng dBµV	Reading listed by margin.			dB	Test Distance: 3 Meters				
			T1 dB	T2 dB	T3 dB		Dist Table	Corr dBµV/m	Spec dBµV/m	Margin dB	Polar Ant
1	4823.338M	61.5	+54.7	+34.8	+9.9	+0.0	51.5	54.0	-2.5	Vert	
2	17971.920 M	38.6	+54.6	+44.8	+16.9	+0.0	45.7	54.0	-8.3	Vert	
3	4075.591M	56.8	+54.8	+33.2	+9.7	+0.0	44.9	54.0	-9.1	Vert	
4	17489.990 M	38.7	+54.6	+43.9	+16.1	+0.0	44.1	54.0	-9.9	Vert	
5	3036.553M	59.0	+54.9	+30.3	+9.3	+0.0	43.7	54.0	-10.3	Vert	
6	2689.206M	59.8	+55.0	+29.7	+9.1	+0.0	43.6	54.0	-10.4	Vert	
7	3393.910M	58.2	+54.9	+30.8	+9.4	+0.0	43.5	54.0	-10.5	Vert	
8	12823.330 M	44.8	+55.1	+41.3	+11.1	+0.0	42.1	54.0	-11.9	Vert	

9	5893.407M	52.9	+54.9	+35.6	+8.3	+0.0	41.9	54.0	-12.1	Vert
10	5502.016M	52.5	+54.8	+34.9	+9.0	+0.0	41.6	54.0	-12.4	Vert

EMCE Engineering Date: 1/30/2008 Time: 2:59:37 PM Socket Mobile, Inc. WO#: 2758  
FCC Rad Average Limits 2483.5 - 12750 Test Distance: 3 Meters Sequence#: 15

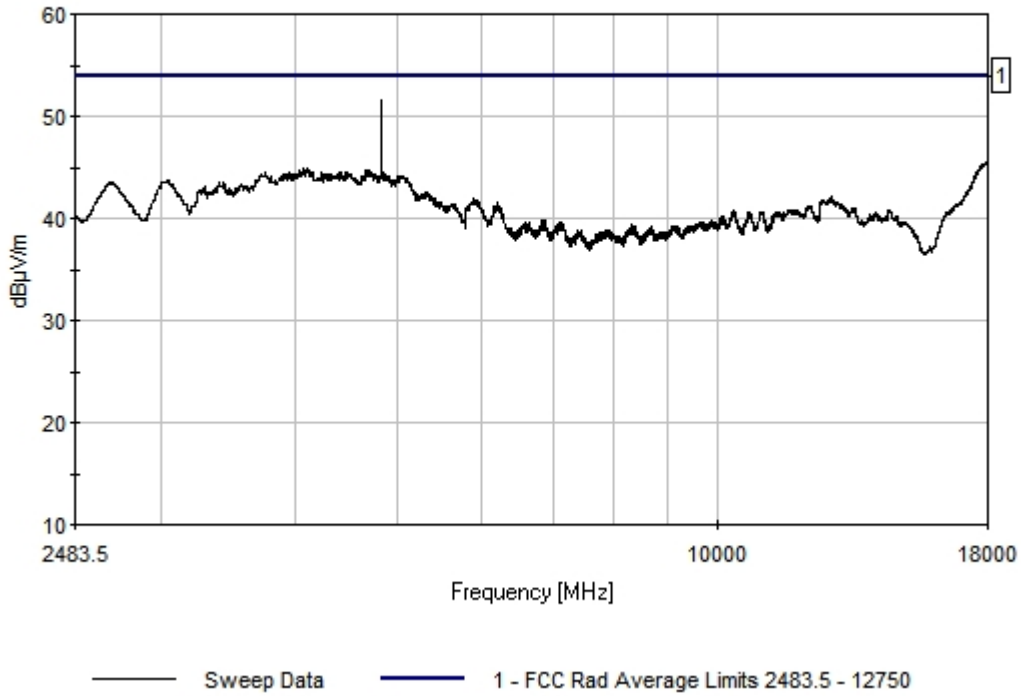

## Restricted Band Spurious Radiated Emissions 2483.5 - 18000 MHz

### Channel 1 / 2412 MHz / OFDM Average

Test Location: EMCE Engineering • 44366 S. Grimmer Blvd • Fremont, CA 94538 • 510-490-4307

Customer: **Socket Communications, Inc.**  
 Specification: **FCC Rad Average Limits 2483.5 - 12750**  
 Work Order #: **2758** Date: 1/30/2008  
 Test Type: **Radiated Scan** Time: 10:48:37 AM  
 Equipment: **SD WLAN** Sequence#: 17  
 Manufacturer: Socket Communications Tested By: Bob Cole  
 Model: SDIO WLAN  
 S/N:

**Test Equipment:**

Function	S/N	Calibration Date	Cal Due Date	Asset #
----------	-----	------------------	--------------	---------

**Equipment Under Test (\* = EUT):**

Function	Manufacturer	Model #	S/N
SD WLAN*	Socket Communications	SDIO WLAN	

**Support Devices:**

Function	Manufacturer	Model #	S/N
PDA (Host)	Dell	C22	

**Test Conditions / Notes:**

2412 MHz 1 MHz RBW/ 10 Hz VBW 6 MBS OFDM
--

**Transducer Legend:**

T1=84125 RF Amps	T2=A.H. SAS-200/571 Horn 1 meter
T3=cable1 18 GHz test	

**Measurement Data:**

Reading listed by margin.

Test Distance: 3 Meters

#	Freq MHz	Rdng dBµV	T1 dB	T2 dB	T3 dB	dB	Dist Table	Corr dBµV/m	Spec dBµV/m	Margin dB	Polar Ant
1	4823.338M	62.2	+54.7	+34.8	+9.9		+0.0	52.2	54.0	-1.8	Vert
2	17974.930M	38.5	+54.6	+44.8	+16.9		+0.0	45.6	54.0	-8.4	Vert
3	4114.630M	57.3	+54.8	+33.3	+9.7		+0.0	45.5	54.0	-8.5	Vert
4	3035.552M	59.6	+54.9	+30.3	+9.3		+0.0	44.3	54.0	-9.7	Vert
5	2675.192M	60.5	+55.0	+29.6	+9.1		+0.0	44.2	54.0	-9.8	Vert
6	3429.946M	58.7	+54.9	+30.8	+9.5		+0.0	44.1	54.0	-9.9	Vert
7	17486.990M	38.5	+54.6	+43.9	+16.1		+0.0	43.9	54.0	-10.1	Vert
8	5933.447M	53.3	+54.9	+35.7	+8.2		+0.0	42.3	54.0	-11.7	Vert
9	5503.017M	53.1	+54.8	+34.9	+9.0		+0.0	42.2	54.0	-11.8	Vert
10	12823.330M	44.9	+55.1	+41.3	+11.1		+0.0	42.2	54.0	-11.8	Vert

EMCE Engineering Date: 1/30/2008 Time: 10:48:37 AM Socket Mobile, Inc. WO#: 2758  
FCC Rad Average Limits 2483.5 - 12750 Test Distance: 3 Meters Sequence#: 17

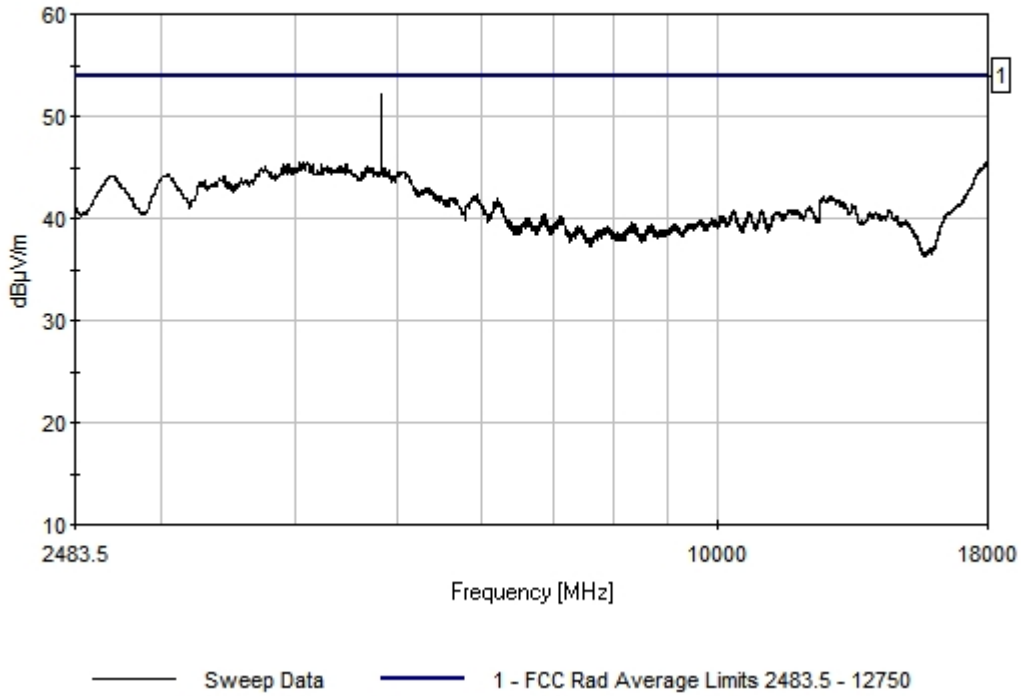

## Restricted Band Spurious Radiated Emissions 2483.5 - 18000 MHz

### Channel 6 / 2437 MHz / CCK Average

Test Location: EMCE Engineering • 44366 S. Grimmer Blvd • Fremont, CA 94538 • 510-490-4307

Customer:	<b>Socket Communications, Inc.</b>	Date:	1/30/2008
Specification:	<b>FCC Rad Average Limits 2483.5 - 12750</b>	Time:	12:48:03 PM
Work Order #:	<b>2758</b>	Sequence#:	14
Test Type:	<b>Radiated Scan</b>	Tested By:	Bob Cole
Equipment:	<b>SD WLAN</b>		
Manufacturer:	Socket Communications		
Model:	SDIO WLAN		
S/N:			

**Test Equipment:**

Function	S/N	Calibration Date	Cal Due Date	Asset #
----------	-----	------------------	--------------	---------

**Equipment Under Test (\* = EUT):**

Function	Manufacturer	Model #	S/N
SD WLAN*	Socket Communications	SDIO WLAN	

**Support Devices:**

Function	Manufacturer	Model #	S/N
PDA (Host)	Dell	C22	

**Test Conditions / Notes:**

2437 MHz 1 MHz RBW/ 10 Hz VBW 5.5 MBS CCK
---

**Transducer Legend:**

T1=84125 RF Amps	T2=A.H. SAS-200/571 Horn 1 meter
T3=cable1 18 GHz test	

**Measurement Data:**

Reading listed by margin.

Test Distance: 3 Meters

#	Freq MHz	Rdng dBµV	T1 dB	T2 dB	T3 dB	dB	Dist Table	Corr dBµV/m	Spec dBµV/m	Margin dB	Polar Ant
1	4873.388M	59.2	+54.7	+34.9	+10.0		+0.0	49.4	54.0	-4.6	Vert
2	17971.920 M	38.5	+54.6	+44.8	+16.9		+0.0	45.6	54.0	-8.4	Vert
3	4115.631M	56.9	+54.8	+33.3	+9.7		+0.0	45.1	54.0	-8.9	Vert
4	17486.990 M	38.6	+54.6	+43.9	+16.1		+0.0	44.0	54.0	-10.0	Vert
5	3034.551M	59.2	+54.9	+30.3	+9.3		+0.0	43.9	54.0	-10.1	Vert
6	2677.194M	60.1	+55.0	+29.6	+9.1		+0.0	43.8	54.0	-10.2	Vert
7	3429.946M	58.3	+54.9	+30.8	+9.5		+0.0	43.7	54.0	-10.3	Vert
8	5893.407M	53.0	+54.9	+35.6	+8.3		+0.0	42.0	54.0	-12.0	Vert
9	12776.280 M	44.8	+55.1	+41.2	+11.0		+0.0	41.9	54.0	-12.1	Vert

10	5504.018M	52.7	+54.8	+34.9	+9.0	+0.0	41.8	54.0	-12.2	Vert
----	-----------	------	-------	-------	------	------	------	------	-------	------

EMCE Engineering Date: 1/30/2008 Time: 12:48:03 PM Socket Mobile, Inc. WO#: 2758  
FCC Rad Average Limits 2483.5 - 12750 Test Distance: 3 Meters Sequence#: 14

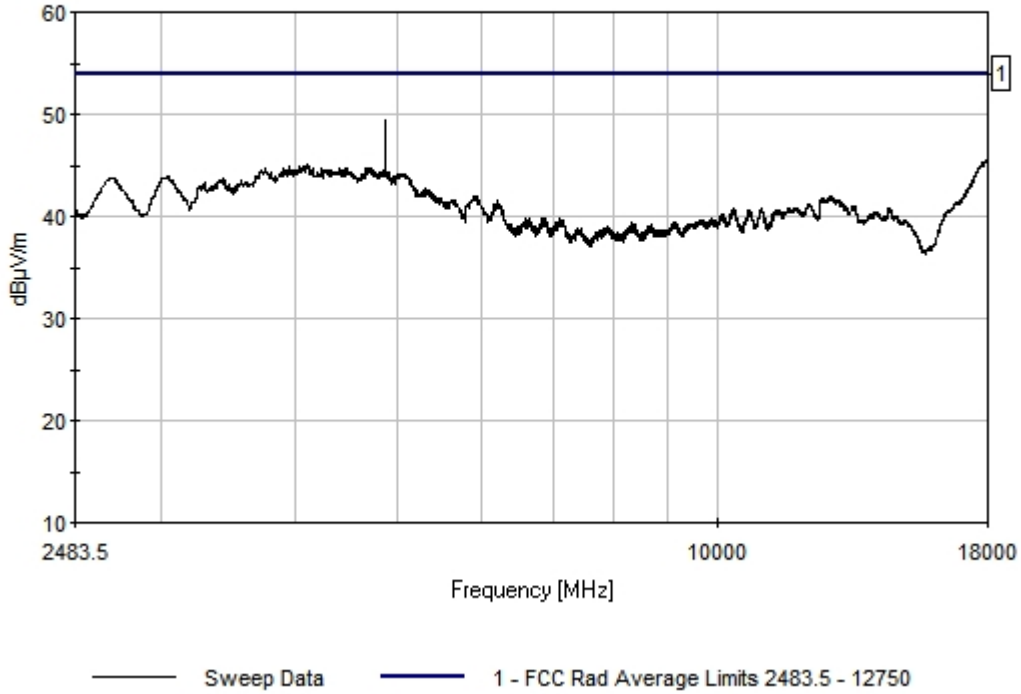

## Restricted Band Spurious Radiated Emissions 2483.5 - 18000 MHz

### Channel 6 / 2437 MHz / OFDM Average

Test Location: EMCE Engineering • 44366 S. Grimmer Blvd • Fremont, CA 94538 • 510-490-4307

Customer: **Socket Communications, Inc.**  
 Specification: **FCC Rad Average Limits 2483.5 - 12750**  
 Work Order #: **2758** Date: 1/30/2008  
 Test Type: **Radiated Scan** Time: 11:43:22 AM  
 Equipment: **SD WLAN** Sequence#: 14  
 Manufacturer: Socket Communications Tested By: Bob Cole  
 Model: SDIO WLAN  
 S/N:

**Test Equipment:**

Function	S/N	Calibration Date	Cal Due Date	Asset #
----------	-----	------------------	--------------	---------

**Equipment Under Test (\* = EUT):**

Function	Manufacturer	Model #	S/N
SD WLAN*	Socket Communications	SDIO WLAN	

**Support Devices:**

Function	Manufacturer	Model #	S/N
PDA (Host)	Dell	C22	

**Test Conditions / Notes:**

2437 MHz 1 MHz RBW/ 10 Hz VBW 6 MBS OFDM
--

**Transducer Legend:**

T1=84125 RF Amps	T2=A.H. SAS-200/571 Horn 1 meter
T3=cable1 18 GHz test	

**Measurement Data:**

Reading listed by margin.

Test Distance: 3 Meters

#	Freq MHz	Rdng dBµV	T1 listed by margin			T2 listed by margin			T3 listed by margin			Dist Table	Corr dBµV/m	Spec dBµV/m	Margin dB	Polar Ant
			T1 dB	T2 dB	T3 dB	T1 dB	T2 dB	T3 dB	T1 dB	T2 dB	T3 dB					
1	4873.388M	58.8	+54.7	+34.9	+10.0	+0.0	49.0	54.0	-5.0	Vert						
2	17971.920 M	38.5	+54.6	+44.8	+16.9	+0.0	45.6	54.0	-8.4	Vert						
3	4074.590M	57.0	+54.8	+33.2	+9.7	+0.0	45.1	54.0	-8.9	Vert						
4	3036.553M	59.3	+54.9	+30.3	+9.3	+0.0	44.0	54.0	-10.0	Vert						
5	17489.990 M	38.6	+54.6	+43.9	+16.1	+0.0	44.0	54.0	-10.0	Vert						
6	2677.194M	60.1	+55.0	+29.6	+9.1	+0.0	43.8	54.0	-10.2	Vert						
7	3392.909M	58.4	+54.9	+30.8	+9.4	+0.0	43.7	54.0	-10.3	Vert						
8	5888.402M	53.0	+54.9	+35.6	+8.3	+0.0	42.0	54.0	-12.0	Vert						
9	12823.330 M	44.7	+55.1	+41.3	+11.1	+0.0	42.0	54.0	-12.0	Vert						



10	5500.014M	52.7	+54.8	+34.9	+9.0	+0.0	41.8	54.0	-12.2	Vert
----	-----------	------	-------	-------	------	------	------	------	-------	------

EMCE Engineering Date: 1/30/2008 Time: 11:43:22 AM Socket Mobile, Inc. WO#: 2758  
FCC Rad Average Limits 2483.5 - 12750 Test Distance: 3 Meters Sequence#: 14

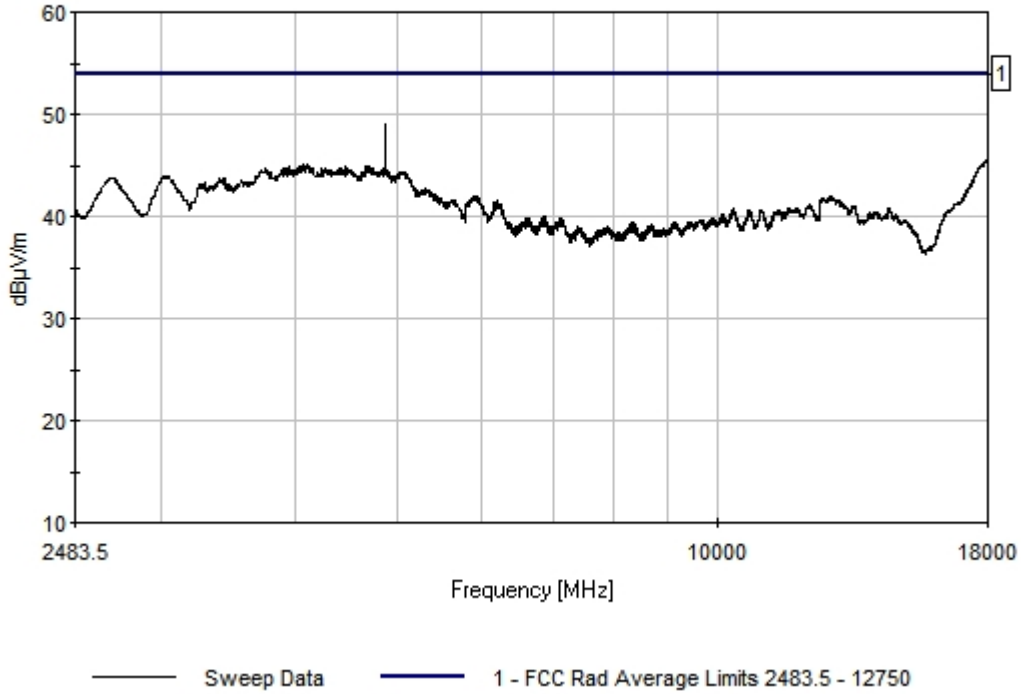

## Restricted Band Spurious Radiated Emissions 2483.5 - 18000 MHz

### Channel 11 / 2462 MHz / CCK Average

Test Location: EMCE Engineering • 44366 S. Grimmer Blvd • Fremont, CA 94538 • 510-490-4307

Customer: **Socket Communications, Inc.**  
 Specification: **FCC Rad Average Limits 2483.5 - 12750**  
 Work Order #: **2758** Date: 1/30/2008  
 Test Type: **Radiated Scan** Time: 12:33:45 PM  
 Equipment: **SD WLAN** Sequence#: 11  
 Manufacturer: Socket Communications Tested By: Bob Cole  
 Model: SDIO WLAN  
 S/N:

**Test Equipment:**

Function	S/N	Calibration Date	Cal Due Date	Asset #
----------	-----	------------------	--------------	---------

**Equipment Under Test (\* = EUT):**

Function	Manufacturer	Model #	S/N
SD WLAN*	Socket Communications	SDIO WLAN	

**Support Devices:**

Function	Manufacturer	Model #	S/N
PDA (Host)	Dell	C22	

**Test Conditions / Notes:**

2462 MHz 1 MHz RBW/ 10 Hz VBW 5.5 MBS CCK
---

**Transducer Legend:**

T1=84125 RF Amps	T2=A.H. SAS-200/571 Horn 1 meter
T3=cable1 18 GHz test	

**Measurement Data:**

Reading listed by margin.

Test Distance: 3 Meters

#	Freq MHz	Rdng dBµV	Reading listed by margin.			Dist Table	Corr dBµV/m	Spec dBµV/m	Margin dB	Polar Ant
			T1 dB	T2 dB	T3 dB					
1	4923.438M	60.3	+54.7	+35.0	+10.0	+0.0	50.6	54.0	-3.4	Vert
2	17971.920M	38.5	+54.6	+44.8	+16.9	+0.0	45.6	54.0	-8.4	Vert
3	4113.629M	56.9	+54.8	+33.3	+9.7	+0.0	45.1	54.0	-8.9	Vert
4	17486.990M	38.6	+54.6	+43.9	+16.1	+0.0	44.0	54.0	-10.0	Vert
5	3034.551M	59.2	+54.9	+30.3	+9.3	+0.0	43.9	54.0	-10.1	Vert
6	2684.201M	60.0	+55.0	+29.7	+9.1	+0.0	43.8	54.0	-10.2	Vert
7	3430.947M	58.3	+54.9	+30.8	+9.5	+0.0	43.7	54.0	-10.3	Vert
8	5890.404M	53.0	+54.9	+35.6	+8.3	+0.0	42.0	54.0	-12.0	Vert
9	12777.280M	44.8	+55.1	+41.2	+11.0	+0.0	41.9	54.0	-12.1	Vert

10	5500.014M	52.6	+54.8	+34.9	+9.0	+0.0	41.7	54.0	-12.3	Vert
----	-----------	------	-------	-------	------	------	------	------	-------	------

EMCE Engineering Date: 1/30/2008 Time: 12:33:45 PM Socket Mobile, Inc. WO#: 2758  
FCC Rad Average Limits 2483.5 - 12750 Test Distance: 3 Meters Sequence#: 11

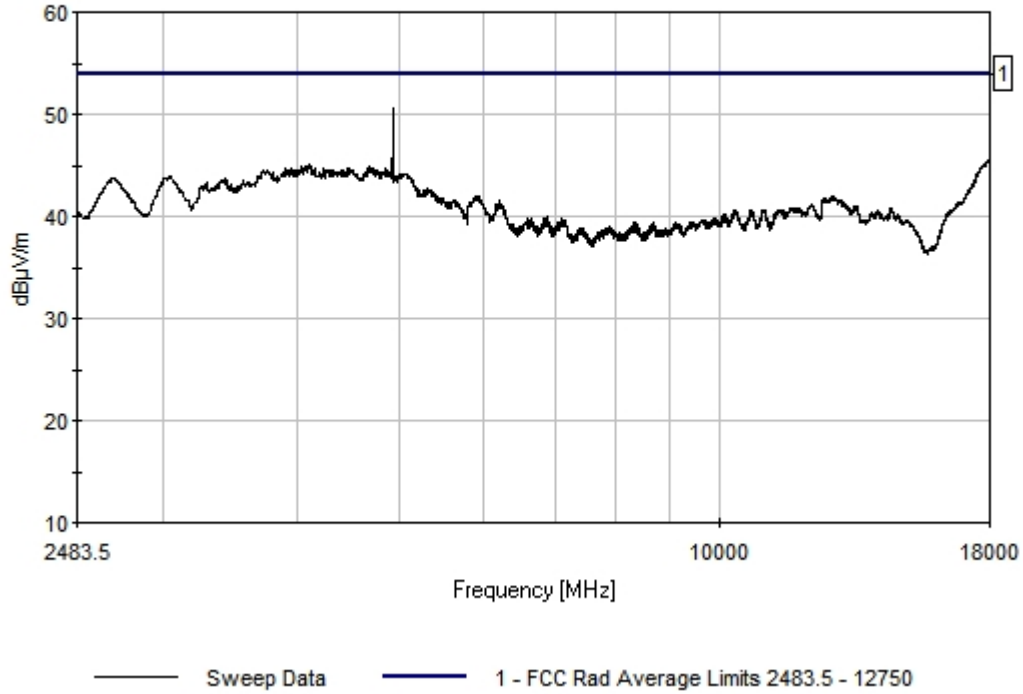

## Restricted Band Spurious Radiated Emissions 2483.5 - 18000 MHz

### Channel 11 / 2462 MHz / OFDM Average

Test Location: EMCE Engineering • 44366 S. Grimmer Blvd • Fremont, CA 94538 • 510-490-4307

Customer: **Socket Communications, Inc.**  
 Specification: **FCC Rad Average Limits 2483.5 - 12750**  
 Work Order #: **2758** Date: 1/30/2008  
 Test Type: **Radiated Scan** Time: 12:13:24 PM  
 Equipment: **SD WLAN** Sequence#: 13  
 Manufacturer: Socket Communications Tested By: Bob Cole  
 Model: SDIO WLAN  
 S/N:

**Test Equipment:**

Function	S/N	Calibration Date	Cal Due Date	Asset #
----------	-----	------------------	--------------	---------

**Equipment Under Test (\* = EUT):**

Function	Manufacturer	Model #	S/N
SD WLAN*	Socket Communications	SDIO WLAN	

**Support Devices:**

Function	Manufacturer	Model #	S/N
PDA (Host)	Dell	C22	

**Test Conditions / Notes:**

2462 MHz 1 MHz RBW/ 10 Hz VBW 6 MBS OFDM
--

**Transducer Legend:**

T1=84125 RF Amps	T2=A.H. SAS-200/571 Horn 1 meter
T3=cable1 18 GHz test	

**Measurement Data:**

Reading listed by margin.

Test Distance: 3 Meters

#	Freq MHz	Rdng dBµV	T1 dB	T2 dB	T3 dB	dB	Dist Table	Corr dBµV/m	Spec dBµV/m	Margin dB	Polar Ant
1	4923.438M	60.6	+54.7	+35.0	+10.0		+0.0	50.9	54.0	-3.1	Vert
2	17971.920M	38.5	+54.6	+44.8	+16.9		+0.0	45.6	54.0	-8.4	Vert
3	4073.589M	57.1	+54.8	+33.2	+9.7		+0.0	45.2	54.0	-8.8	Vert
4	3033.550M	59.3	+54.9	+30.3	+9.3		+0.0	44.0	54.0	-10.0	Vert
5	17486.990M	38.6	+54.6	+43.9	+16.1		+0.0	44.0	54.0	-10.0	Vert
6	2684.201M	60.1	+55.0	+29.7	+9.1		+0.0	43.9	54.0	-10.1	Vert
7	3427.944M	58.4	+54.9	+30.8	+9.5		+0.0	43.8	54.0	-10.2	Vert
8	5888.402M	53.0	+54.9	+35.6	+8.3		+0.0	42.0	54.0	-12.0	Vert
9	12821.330M	44.8	+55.1	+41.2	+11.1		+0.0	42.0	54.0	-12.0	Vert
10	5501.015M	52.8	+54.8	+34.9	+9.0		+0.0	41.9	54.0	-12.1	Vert

EMCE Engineering Date: 1/30/2008 Time: 12:13:24 PM Socket Mobile, Inc. WO#: 2758  
FCC Rad Average Limits 2483.5 - 12750 Test Distance: 3 Meters Sequence#: 13

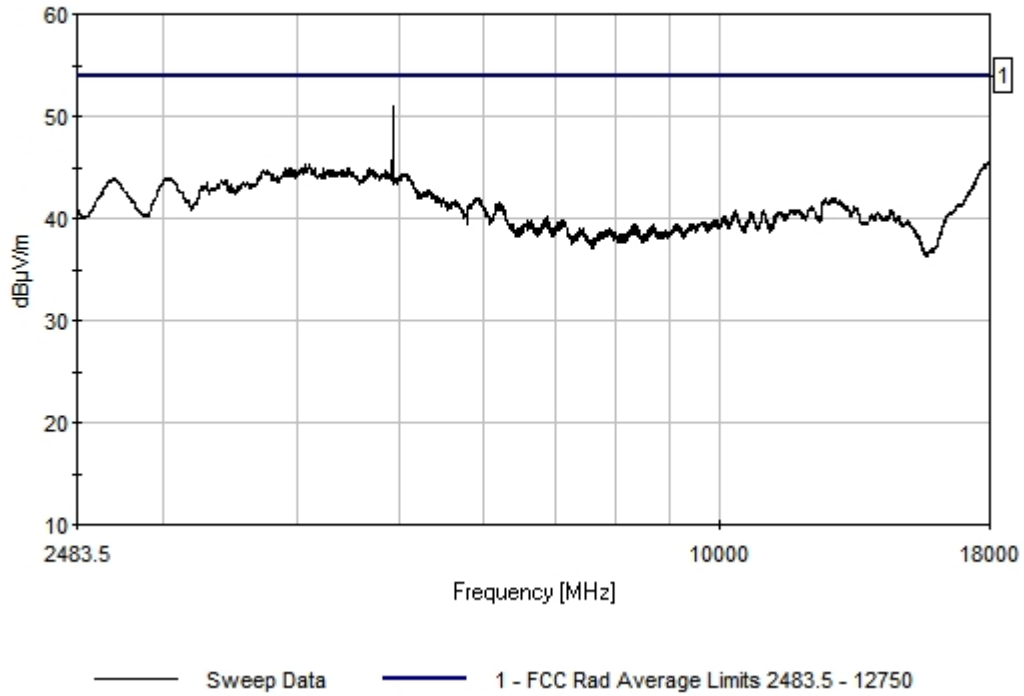

## RECEIVE MODE RADIATED EMISSIONS MEASUREMENT

Test Location: EMCE Engineering •44366 S. Grimmer Blvd • Fremont, CA 94538 • 510-490-4307

Customer: **Socket Communications**  
 Specification: **FCC Rad Average Limits 1000 - 18000**  
 Work Order #: **2758** Date: 1/29/2008  
 Test Type: **Radiated Scan** Time: 12:32:13 PM  
 Equipment: **SD WLAN** Sequence#: 1  
 Manufacturer: Socket Communications Tested By: Bob Cole  
 Model: SDIO WLAN  
 S/N:

**Test Equipment:**

Function	S/N	Calibration Date	Cal Due Date	Asset #
----------	-----	------------------	--------------	---------

**Equipment Under Test (\* = EUT):**

Function	Manufacturer	Model #	S/N
SD WLAN*	Socket Communications	SDIO WLAN	

**Support Devices:**

Function	Manufacturer	Model #	S/N
PDA (Host)	Dell	C22	

**Test Conditions / Notes:**

--

**Transducer Legend:**

T1=84125 RF Amps	T2=A.H. SAS-200/571 Horn 1 meter
T3=cable1 18 GHz test	

**Measurement Data:** Reading listed by margin. Test Distance: 3 Meters

#	Freq MHz	Rdng dBµV	T1 dB	T2 dB	T3 dB	dB	Dist Table	Corr dBµV/m	Spec dBµV/m	Margin dB	Polar Ant
1	1300.300M	76.8	+54.9	+24.0	+6.4		+0.0	52.3	54.0	-1.7	Vert
2	1102.102M	75.3	+54.8	+23.6	+6.1		+0.0	50.2	54.0	-3.8	Vert
3	4823.820M	60.0	+54.7	+34.8	+9.9		+0.0	50.0	54.0	-4.0	Vert
4	1033.033M	74.8	+54.8	+23.5	+6.0		+0.0	49.5	54.0	-4.5	Vert
5	1001.001M	73.3	+54.8	+23.5	+6.0		+0.0	48.0	54.0	-6.0	Vert
6	1200.200M	72.8	+54.9	+23.7	+6.3		+0.0	47.9	54.0	-6.1	Vert
7	1400.400M	72.1	+54.9	+24.2	+6.5		+0.0	47.9	54.0	-6.1	Vert
8	1503.503M	71.4	+54.9	+24.5	+6.6		+0.0	47.6	54.0	-6.4	Vert
9	1600.600M	70.8	+54.9	+24.8	+6.7		+0.0	47.4	54.0	-6.6	Vert

10	1072.072M	71.9	+54.8	+23.6	+6.1	+0.0	46.8	54.0	-7.2	Vert
----	-----------	------	-------	-------	------	------	------	------	------	------

EMCE Engineering Date: 1/29/2008 Time: 12:32:13 PM Socket Communications WO#: 2758  
FCC Rad Average Limits 1000 - 18000 Test Distance: 3 Meters Sequence#: 1

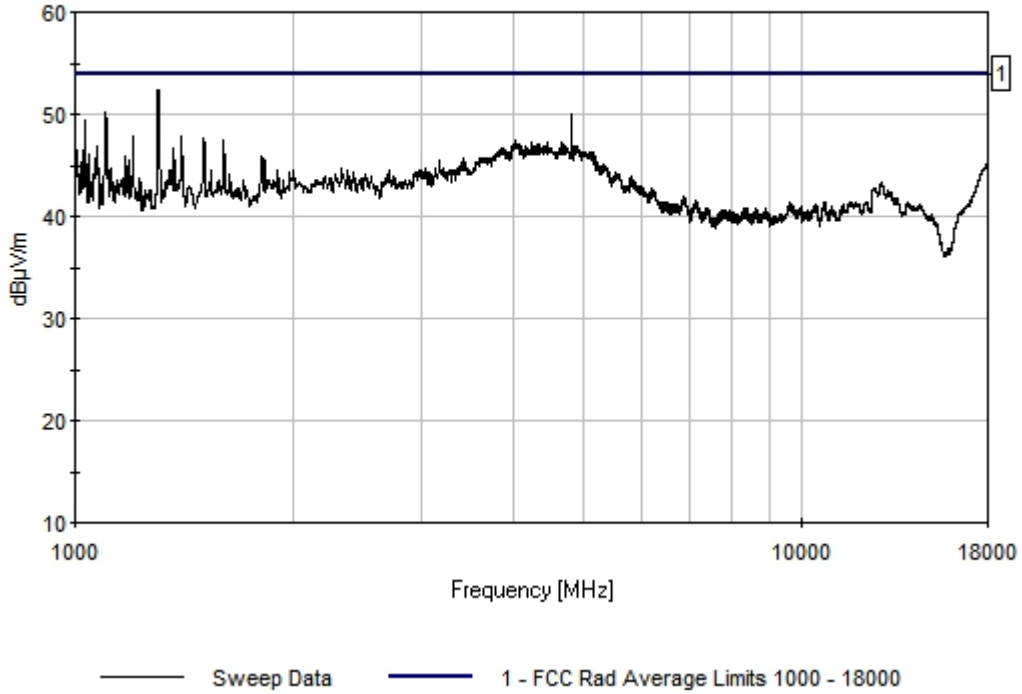

## AC LINE CONDUCTED EMISSIONS MEASUREMENT

### AC Line Conducted Emissions Measurement 150 kHz – 30 MHz

<b>EUT</b>	<b>GO WI-FI! P300-EXT</b>
<b>Test setup</b>	C (conducted)
<b>Temp, Humidity, Air Pressure</b>	62° F, 30.69
<b>Date of Measurement</b>	1/22/08
<b>Measured by</b>	Bob Cole
<b>Result</b>	PASSED

### EUT operation mode

<b>EUT operation mode</b>	6 Mbit modulation [OFDM]
<b>EUT channel</b>	1
<b>EUT TX power level</b>	Maximum
<b>EUT operation voltage</b>	120 VAC



**LINE CONDUCTED EMISSIONS, .15 - 30 MHz**  
**EN 55022 Class B Limits**

**LINE 1**

Test Location: EMCE Engineering •44366 S. Grimmer Blvd • Fremont, CA 94538 • 510-490-4307

Customer: **Socket Communications**  
 Specification: **EN55022 B COND [AVE]**  
 Work Order #: **2758**  
 Test Type: **Conducted Emissions**  
 Equipment: **SD WLAN**  
 Manufacturer: **Socket Communications**  
 Model: **SDIO WLAN**  
 S/N:

Date: 1/22/08  
 Time: 10:55:09 AM  
 Sequence#: 1  
 Tested By: Bob Cole  
 120V 60Hz

***Test Equipment:***

Function	S/N	Calibration Date	Cal Due Date	Asset #
----------	-----	------------------	--------------	---------

***Equipment Under Test (\* = EUT):***

Function	Manufacturer	Model #	S/N
SD WLAN*	Socket Communications	SDIO WLAN	

***Support Devices:***

Function	Manufacturer	Model #	S/N
PDA (Host)	Dell	C22	

***Test Conditions / Notes:***

--

***Transducer Legend:***

T1=cable5 test	T2=HP 11947A Transient Limiter
T3=LISN 1	

***Measurement Data:***      Reading listed by margin.      Test Lead: Line 1

#	Freq MHz	Rdng dB $\mu$ V	T1 dB	T2 dB	T3 dB	Dist dB	Table	Corr dB $\mu$ V	Spec dB $\mu$ V	Margin dB	Polar Ant
1	150.000k	32.3	+0.0	+9.9	+1.1	+0.0		43.3	56.0	-12.7	Black
2	241.627k	27.8	+0.0	+9.9	+1.0	+0.0		38.7	52.0	-13.3	Black
3	490.330k	20.7	+0.1	+10.0	+0.7	+0.0		31.5	46.2	-14.7	Black
4	363.797k	22.9	+0.0	+10.0	+0.8	+0.0		33.7	48.6	-14.9	Black
5	737.578k	19.9	+0.1	+10.0	+0.6	+0.0		30.6	46.0	-15.4	Black
6	949.301k	19.9	+0.1	+10.0	+0.5	+0.0		30.5	46.0	-15.5	Black
7	589.956k	18.2	+0.1	+10.0	+0.7	+0.0		29.0	46.0	-17.0	Black
8	1.196M	17.8	+0.1	+10.0	+0.5	+0.0		28.4	46.0	-17.6	Black
9	2.161M	17.5	+0.2	+10.0	+0.6	+0.0		28.3	46.0	-17.7	Black
10	16.517M	21.1	+0.3	+10.0	+0.9	+0.0		32.3	50.0	-17.7	Black

EMCE Engineering Socket Communications WO#: 2758  
EN55022 B COND [AVE] Test Lead: Line 1 120V 60Hz Sequence#: 1

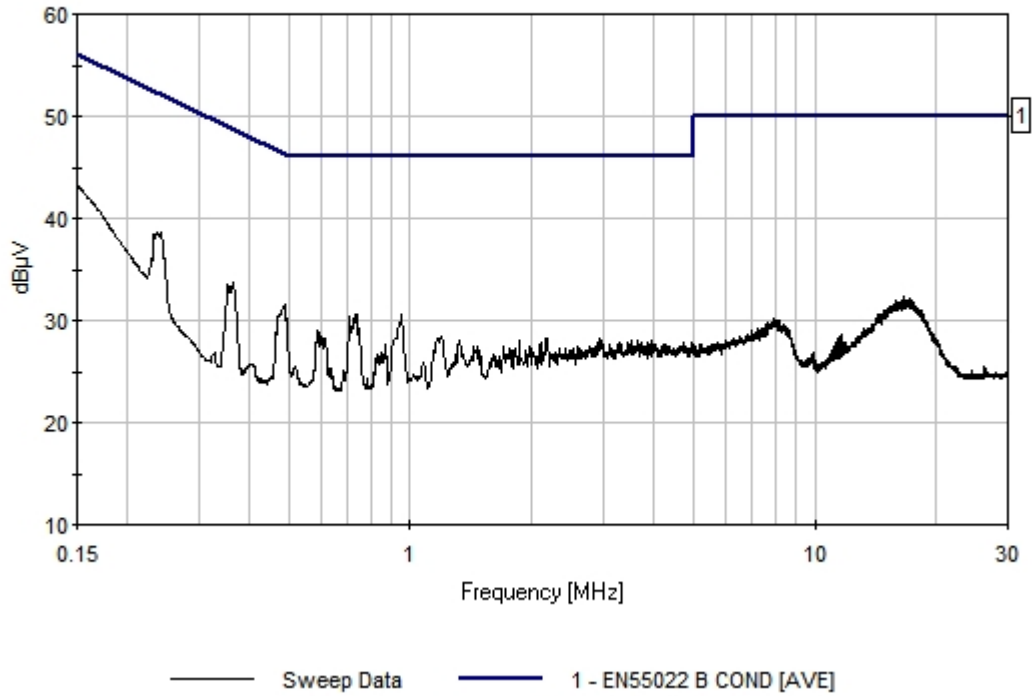

Test Location: EMCE Engineering •44366 S. Grimmer Blvd • Fremont, CA 94538 • 510-490-4307

Customer: **Socket Communications**  
 Specification: **EN55022 B COND [AVE]**  
 Work Order #: **2758**  
 Test Type: **Conducted Emissions**  
 Equipment: **SD WLAN**  
 Manufacturer: **Socket Communications**  
 Model: **SDIO WLAN**  
 S/N:

Date: 1/22/08  
 Time: 11:02:34 AM  
 Sequence#: 2  
 Tested By: **Bob Cole**  
 120V 60Hz

**Test Equipment:**

Function	S/N	Calibration Date	Cal Due Date	Asset #
----------	-----	------------------	--------------	---------

**Equipment Under Test (\* = EUT):**

Function	Manufacturer	Model #	S/N
SD WLAN*	Socket Communications	SDIO WLAN	

**Support Devices:**

Function	Manufacturer	Model #	S/N
PDA (Host)	Dell	C22	

**Test Conditions / Notes:**

--

**Transducer Legend:**

T1=cable5 test	T2=HP 11947A Transient Limiter
T3=LISN 1	

**Measurement Data:**

Reading listed by margin.

Test Lead: Line 2

#	Freq MHz	Rdng dBµV	T1 dB	T2 dB	T3 dB	Dist dB	Dist Table	Corr dBµV	Spec dBµV	Margin dB	Polar Ant
1	749.940k	29.6	+0.1	+10.0	+0.6	+0.0		40.3	46.0	-5.7	Line
2	500.510k	25.3	+0.1	+10.0	+0.7	+0.0		36.1	46.0	-9.9	Line
3	245.263k	30.3	+0.0	+9.9	+0.9	+0.0		41.1	51.9	-10.8	Line
4	368.887k	26.0	+0.1	+10.0	+0.8	+0.0		36.9	48.5	-11.6	Line
5	627.043k	23.4	+0.1	+10.0	+0.6	+0.0		34.1	46.0	-11.9	Line
6	150.000k	32.3	+0.0	+9.9	+1.1	+0.0		43.3	56.0	-12.7	Line
7	1.226M	22.5	+0.1	+10.0	+0.5	+0.0		33.1	46.0	-12.9	Line
8	1.596M	22.2	+0.1	+10.0	+0.6	+0.0		32.9	46.0	-13.1	Line
9	1.353M	22.2	+0.1	+10.0	+0.5	+0.0		32.8	46.0	-13.2	Line
10	874.291k	20.7	+0.1	+10.0	+0.5	+0.0		31.3	46.0	-14.7	Line

EMCE Engineering Socket Communications WO#: 2758  
EN55022 B COND [AVE] Test Lead: Line 2 120V 60Hz Sequence#: 2

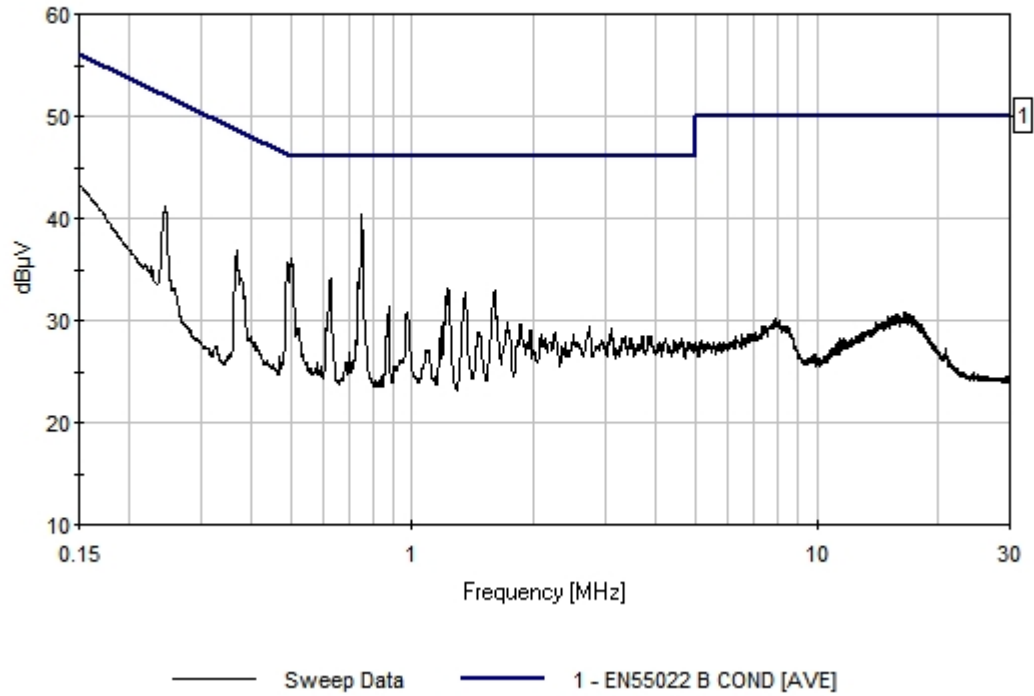

## 7.0 TEST EQUIPMENT

Antenna Conducted Measurements:

Equipment	Type	Manufacturer	Calibration Due Date
Spectrum Analyzer	8593EM	Hewlett-Packard	2/1/08
Oscilloscope	TDS820	Tektronix	2/1/08
RF Power Meter	MA2488A	Anritsu	11/1/08
Power Sensor	ML2491A	Anritsu	11/1/08
Coaxial cable	SMA Male – Reverse SMA Male (Length = 20 cm)	EMCE	10/1/08

Spurious RF radiated emissions:

Equipment	Type	Manufacturer	Calibration Due Date
EMI Analyzer System	84125B	Hewlett-Packard	2/1/08
Spectrum Analyzer	8566B	Hewlett-Packard	4/15/08
Pre-Amp	83051A	Hewlett-Packard	2/1/08
Pre-Amp	83017A	Hewlett-Packard	2/1/08
High Pass Filter	9701	CMT	2/1/08
Horn Antenna	SAS 200/571	AH Systems	6/15/08
Cable	N – N (3 Meters)	EMCE	11/22/07

Note: The HP 84125B EMC Analyzer System is calibrated as a system, including the analyzer, pre-amps, filters, and cable.

EN 55022 (AC powerline conducted emissions)

Equipment	Type	Manufacturer	Calibration Due Date
Spectrum analyzer	8568B	Hewlett-Packard	2/1/08
LISN	3810/2	EMCO	10/1/08
Coaxial cable	N Type – BNC (5 Meters)	Own	10/1/08

# RADIATED SPURIOUS EMISSIONS MEASUREMENTS (MODULAR APPROVAL PER DA 00-1407, REQUIREMENT #5)

## Setup C (Radiated measurements)

### Operational description

### RADIATED EMISSIONS MEASUREMENTS

This setup was used in radiated spurious emissions measurements.

The EUT was manipulated to find the maximum emissions at 2412, 2437 and 2462 MHz. This was used as the X orientation. Y and Z are orthogonal orientations from the X setup..

Worst case data is presented.

THIS SETUP USED FOR *RADIATED SPURIOUS EMISSIONS*

### *Block diagram*

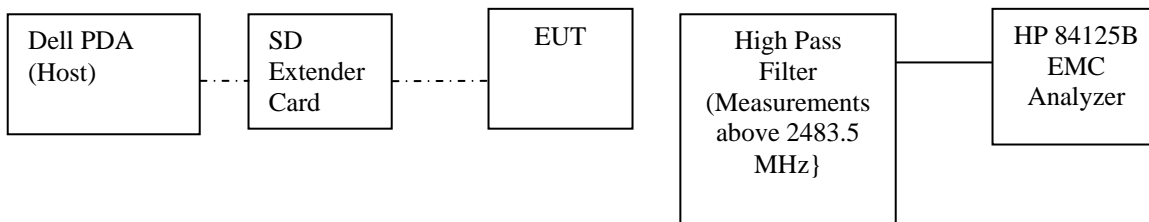

Note: The high –pass filter is used for the Radiated Spurious emissions above 2.4835 GHz. A pass-thru connector is used for Radiated Spurious emissions measurements from 30 MHz – 2.4 GHz.

The solid lines are coaxial cables and the dashed lines are EUT insertion to the test board and/or Host.

## RADIATED SPURIOUS EMISSIONS

### 30 – 1000 MHz

Test Location: EMCE Engineering •44366 S. Grimmer Blvd • Fremont, CA 94538 • 510-490-4307

Customer: **Socket Communications**  
 Specification: **FCC-Restricted Band 30-1000**  
 Work Order #: **2758**  
 Test Type: **Radiated Scan**  
 Equipment:  
 Manufacturer:  
 Model:  
 S/N:

Date: 1/30/2008  
 Time: 1:09:27 PM  
 Sequence#: 2  
 Tested By: Bob Cole

**Test Equipment:**

Function	S/N	Calibration Date	Cal Due Date	Asset #
----------	-----	------------------	--------------	---------

**Equipment Under Test (\* = EUT):**

Function	Manufacturer	Model #	S/N
SD WLAN	Socket Communications	SDIO WLAN	

**Support Devices:**

Function	Manufacturer	Model #	S/N
PDA (Host)	Dell	C22	

**Test Conditions / Notes:**

1 MHz RBW/VBW, 120 kHz QPBW 2412 MHz / 6 MBS / OFDM
--

**Transducer Legend:**

T1=AH SAS-200/543 S/N: 199	T2=AH Log P SAS-200_510 S-N853
T3=cable5 test	T4=8447 Pre-Amp

**Measurement Data:** Reading listed by margin. Test Distance: 3 Meters

#	Freq MHz	Rdng dBµV	T1 dB	T2 dB	T3 dB	T4 dB	Dist Table	Corr dBµV/m	Spec dBµV/m	Margin dB	Polar Ant
1	253.525M	57.4	+15.7	+0.0	+0.7	+26.7	+0.0	47.1	54.0	-6.9	Vert
2	408.460M	54.9	+0.0	+15.4	+1.1	+26.8	+0.0	44.6	54.0	-9.4	Horiz
3	331.939M	52.6	+0.0	+13.9	+1.0	+26.8	+0.0	40.7	54.0	-13.3	Vert
4	263.898M	43.7	+17.4	+0.0	+0.8	+26.7	+0.0	35.2	54.0	-18.8	Horiz
5	278.746M	39.8	+19.9	+0.0	+0.8	+26.7	+0.0	33.8	54.0	-20.2	Vert
6	136.163M	47.5	+12.0	+0.0	+0.7	+26.6	+0.0	33.6	54.0	-20.4	Vert
7	267.356M	39.9	+18.4	+0.0	+0.8	+26.7	+0.0	32.4	54.0	-21.6	Vert
8	985.151M	33.0	+0.0	+23.5	+1.7	+27.0	+0.0	31.2	54.0	-22.8	Vert
9	994.468M	32.3	+0.0	+23.7	+1.6	+27.0	+0.0	30.6	54.0	-23.4	Vert

10	981.562M	31.9	+0.0	+23.4	+1.7	+27.0	+0.0	30.0	54.0	-24.0	Vert
----	----------	------	------	-------	------	-------	------	------	------	-------	------

EMCE Engineering Date: 1/30/2008 Time: 1:09:27 PM Socket Communications WO#: 2758  
FCC-Restricted Band 30-1000 Test Distance: 3 Meters Sequence#: 2

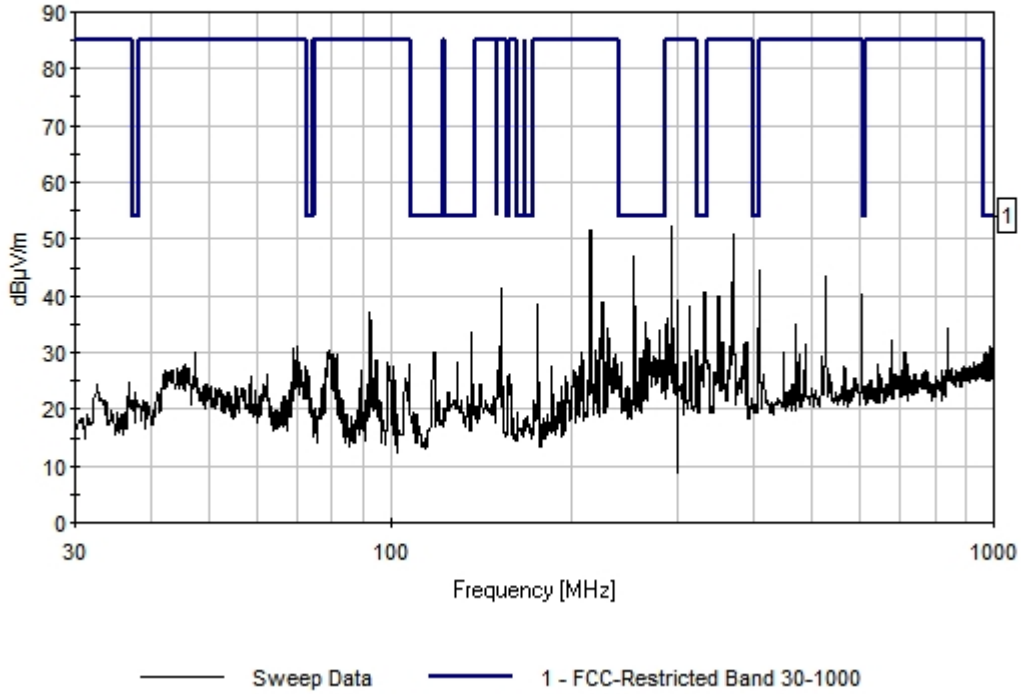



## RADIATED SPURIOUS EMISSIONS

### 1000 - 2400 MHz

Test Location: EMCE Engineering • 44366 S. Grimmer Blvd • Fremont, CA 94538 • 510-490-4307

Customer: **Socket Mobile, Inc.**

Specification: **FCC Peak Restricted Band 1000-2400**

Work Order #: **2758**

Date: 1/31/2008

Test Type: **Radiated Scan**

Time: 12:39:56 PM

Equipment: **SD WLAN**

Sequence#: 25

Manufacturer: **SocketMobile**

Tested By: **Bob Cole**

Model: **SDIO WLAN**

S/N:

**Test Equipment:**

Function	S/N	Calibration Date	Cal Due Date	Asset #
----------	-----	------------------	--------------	---------

**Equipment Under Test (\* = EUT):**

Function	Manufacturer	Model #	S/N
SD WLAN*	SocketMobile	SDIO WLAN	

**Support Devices:**

Function	Manufacturer	Model #	S/N
PDA (Host)	Dell	C22	

**Test Conditions / Notes:**

2412 MHz 1 MHz RBW/ 10 Hz VBW 5.5 MBS CCK EUT in SD Extender - Modular
--

**Transducer Legend:**

T1=84125 RF Amps	T2=cable1 18 GHz test
T3=A.H. SAS-200/571 Horn 1 meter	

**Measurement Data:**

Reading listed by margin.

Test Distance: 3 Meters

#	Freq MHz	Rdng dBµV	T1 dB	T2 dB	T3 dB	dB	Dist Table	Corr dBµV/m	Spec dBµV/m	Margin dB	Polar Ant
1	2387.752M	72.4	+54.8	+8.8	+29.1	+0.0	+0.0	55.5	54.0	+1.5	Vert
	<b>See Bandedge Data</b>										
2	2398.685M	88.3	+54.8	+8.8	+29.2	+0.0	+0.0	71.5	85.0	-13.5	Vert
3	1033.202M	62.3	+54.8	+7.0	+23.5	+0.0	+0.0	38.0	54.0	-16.0	Vert
4	1611.020M	58.4	+54.9	+7.7	+24.9	+0.0	+0.0	36.1	54.0	-17.9	Vert
5	1606.483M	57.6	+54.9	+7.7	+24.9	+0.0	+0.0	35.3	54.0	-18.7	Vert
6	1810.722M	73.5	+55.0	+7.9	+26.1	+0.0	+0.0	52.5	85.0	-32.5	Vert
7	1803.433M	72.5	+55.0	+7.9	+26.0	+0.0	+0.0	51.4	85.0	-33.6	Vert
8	1797.967M	63.6	+55.0	+7.8	+25.9	+0.0	+0.0	42.3	85.0	-42.7	Vert
9	1816.189M	62.5	+55.0	+7.9	+26.2	+0.0	+0.0	41.6	85.0	-43.4	Vert
10	1792.046M	54.9	+55.0	+7.8	+25.9	+0.0	+0.0	33.6	85.0	-51.4	Vert

EMCE Engineering Date: 1/31/2008 Time: 12:39:56 PM Socket Mobile, Inc. WO#: 2758  
FCC Peak Restricted Band 1000-2400 Test Distance: 3 Meters Sequence#: 25

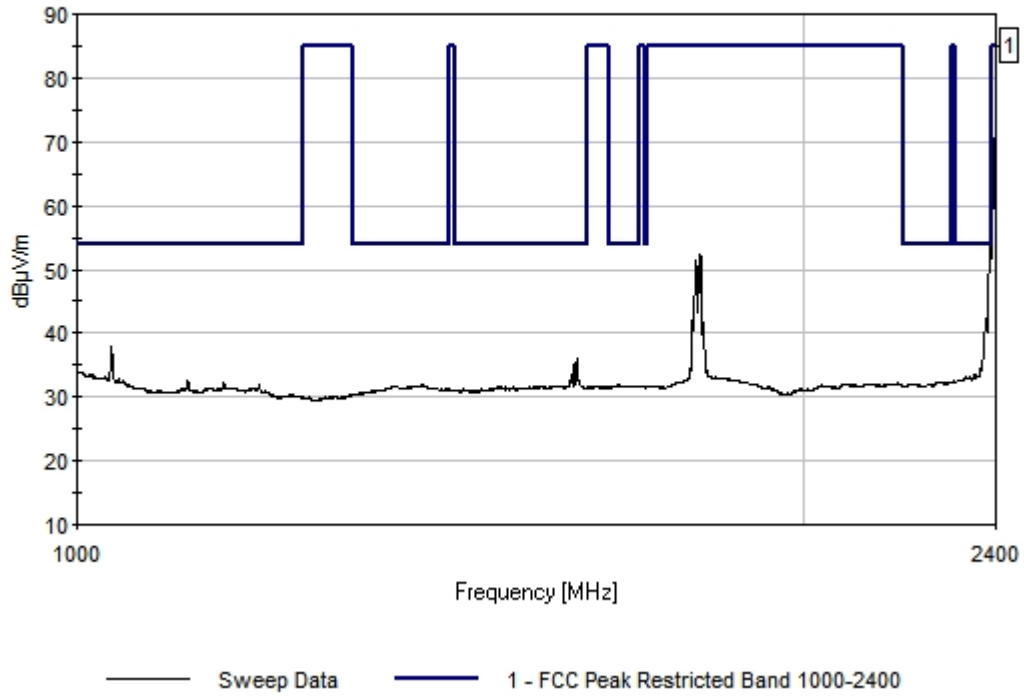

Test Location: EMCE Engineering •44366 S. Grimmer Blvd • Fremont, CA 94538 • 510-490-4307

Customer: **Socket Mobile, Inc.**  
 Specification: **FCC Peak Restricted Band 1000-2400**  
 Work Order #: **2758**  
 Test Type: **Radiated Scan**  
 Equipment: **SD WLAN**  
 Manufacturer: **SocketMobile**  
 Model: **SDIO WLAN**  
 S/N:

Date: 1/31/2008  
 Time: 12:55:14 PM  
 Sequence#: 30  
 Tested By: Bob Cole

**Test Equipment:**

Function	S/N	Calibration Date	Cal Due Date	Asset #
----------	-----	------------------	--------------	---------

**Equipment Under Test (\* = EUT):**

Function	Manufacturer	Model #	S/N
SD WLAN*	SocketMobile	SDIO WLAN	

**Support Devices:**

Function	Manufacturer	Model #	S/N
PDA (Host)	Dell	C22	

**Test Conditions / Notes:**

2412 MHz 1 MHz RBW/ 10 Hz VBW 6 MBS OFDM EUT in SD Extender - Modular
---

**Transducer Legend:**

T1=84125 RF Amps	T2=cable1 18 GHz test
T3=A.H. SAS-200/571 Horn 1 meter	

**Measurement Data:**

Reading listed by margin.

Test Distance: 3 Meters

#	Freq MHz	Rdng dBµV	T1 dB	T2 dB	T3 dB	dB	Dist Table	Corr dBµV/m	Spec dBµV/m	Margin dB	Polar Ant
1	1033.202M	65.2	+54.8	+7.0	+23.5	+0.0	40.9	54.0	-13.1	Vert	
2	2398.078M	87.8	+54.8	+8.8	+29.2	+0.0	71.0	85.0	-14.0	Vert	
3	1111.126M	60.7	+54.8	+7.2	+23.6	+0.0	36.7	54.0	-17.3	Vert	
4	1329.314M	58.6	+54.9	+7.4	+24.0	+0.0	35.1	54.0	-18.9	Vert	
5	1808.900M	69.0	+55.0	+7.9	+26.1	+0.0	48.0	85.0	-37.0	Vert	
6	1792.046M	58.5	+55.0	+7.8	+25.9	+0.0	37.2	85.0	-47.8	Vert	
7	2045.178M	55.3	+55.0	+8.1	+28.6	+0.0	37.0	85.0	-48.0	Vert	

EMCE Engineering Date: 1/31/2008 Time: 12:55:14 PM Socket Mobile, Inc. WO#: 2758  
FCC Peak Restricted Band 1000-2400 Test Distance: 3 Meters Sequence#: 30

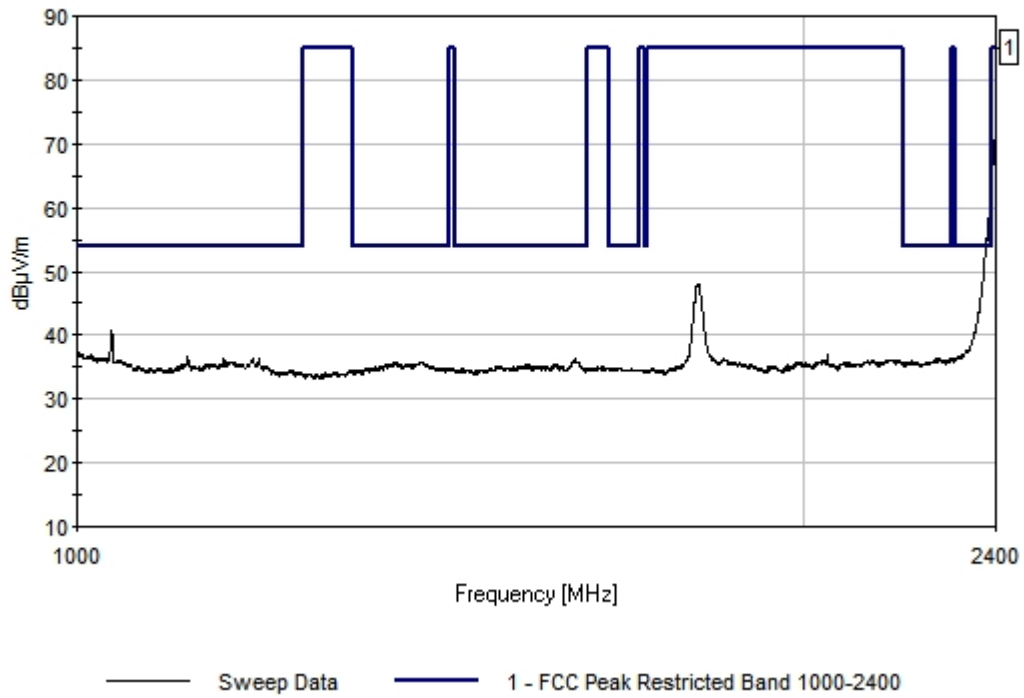

Test Location: EMCE Engineering •44366 S. Grimmer Blvd • Fremont, CA 94538 • 510-490-4307

Customer: **Socket Communications, Inc.**  
 Specification: **FCC Average Limits 1000-2400**  
 Work Order #: **2758**  
 Test Type: **Radiated Scan**  
 Equipment: **SD WLAN**  
 Manufacturer: Socket Communications  
 Model: SDIO WLAN  
 S/N:

Date: 1/31/2008  
 Time: 12:43:11 PM  
 Sequence#: 26  
 Tested By: Bob Cole

**Test Equipment:**

Function	S/N	Calibration Date	Cal Due Date	Asset #
----------	-----	------------------	--------------	---------

**Equipment Under Test (\* = EUT):**

Function	Manufacturer	Model #	S/N
SD WLAN*	Socket Communications	SDIO WLAN	

**Support Devices:**

Function	Manufacturer	Model #	S/N
PDA (Host)	Dell	C22	

**Test Conditions / Notes:**

2437 MHz 1 MHz RBW / 10 Hz VBW 5.5 MBS CCK EUT in SD Extender - Modular
---

**Transducer Legend:**

T1=84125 RF Amps	T2=cable1 18 GHz test
T3=A.H. SAS-200/571 Horn 1 meter	

**Measurement Data:** Reading listed by margin. Test Distance: 3 Meters

#	Freq MHz	Rdng dBµV	T1 dB	T2 dB	T3 dB	Dist dB	Corr dB	Spec dBµV/m	Margin dB	Polar Ant
1	1840.485M	71.3	+55.0	+7.9	+26.5	+0.0	50.7	54.0	-3.3	Vert
2	1848.381M	70.2	+55.0	+7.9	+26.6	+0.0	49.7	54.0	-4.3	Vert
3	1033.541M	64.6	+54.8	+7.0	+23.5	+0.0	40.3	54.0	-13.7	Vert
4	2399.292M	53.4	+54.8	+8.8	+29.2	+0.0	36.6	54.0	-17.4	Vert
5	1643.233M	57.7	+54.9	+7.7	+25.0	+0.0	35.5	54.0	-18.5	Vert

EMCE Engineering Date: 1/31/2008 Time: 12:43:11 PM Socket Mobile, Inc. WO#: 2758  
FCC Average Limits 1000-2400 Test Distance: 3 Meters Sequence#: 26

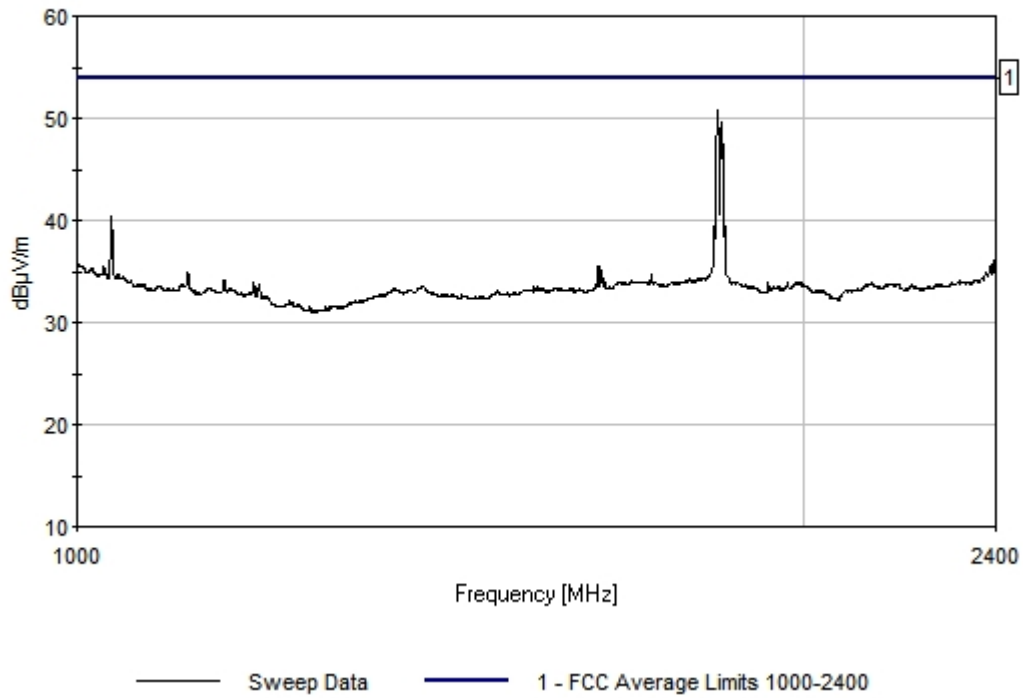

Test Location: EMCE Engineering •44366 S. Grimmer Blvd • Fremont, CA 94538 • 510-490-4307

Customer: **Socket Communications, Inc.**  
 Specification: **FCC Average Limits 1000-2400**  
 Work Order #: **2758**  
 Test Type: **Radiated Scan**  
 Equipment: **SD WLAN**  
 Manufacturer: Socket Communications  
 Model: SDIO WLAN  
 S/N:

Date: 1/31/2008  
 Time: 12:52:33 PM  
 Sequence#: 29  
 Tested By: Bob Cole

**Test Equipment:**

Function	S/N	Calibration Date	Cal Due Date	Asset #
----------	-----	------------------	--------------	---------

**Equipment Under Test (\* = EUT):**

Function	Manufacturer	Model #	S/N
SD WLAN*	Socket Communications	SDIO WLAN	

**Support Devices:**

Function	Manufacturer	Model #	S/N
PDA (Host)	Dell	C22	

**Test Conditions / Notes:**

2437 MHz 1 MHz RBW / 10 Hz VBW 6 MBS OFDM EUT in SD Extender - Modular
--

**Transducer Legend:**

T1=84125 RF Amps	T2=cable1 18 GHz test
T3=A.H. SAS-200/571 Horn 1 meter	

**Measurement Data:** Reading listed by margin. Test Distance: 3 Meters

#	Freq MHz	Rdng dBµV	T1 dB	T2 dB	T3 dB	Dist dB	Corr dB	Spec dBµV/m	Margin dB	Polar Ant
1	2399.292M	69.0	+54.8	+8.8	+29.2	+0.0	52.2	54.0	-1.8	Vert
2	1844.736M	67.7	+55.0	+7.9	+26.6	+0.0	47.2	54.0	-6.8	Vert
3	1033.541M	64.8	+54.8	+7.0	+23.5	+0.0	40.5	54.0	-13.5	Vert
4	1150.088M	59.8	+54.8	+7.2	+23.7	+0.0	35.9	54.0	-18.1	Vert
5	1182.952M	59.7	+54.8	+7.2	+23.7	+0.0	35.8	54.0	-18.2	Vert
6	1647.316M	57.9	+54.9	+7.7	+25.0	+0.0	35.7	54.0	-18.3	Vert

EMCE Engineering Date: 1/31/2008 Time: 12:52:33 PM Socket Mobile, Inc. WO#: 2758  
FCC Average Limits 1000-2400 Test Distance: 3 Meters Sequence#: 29

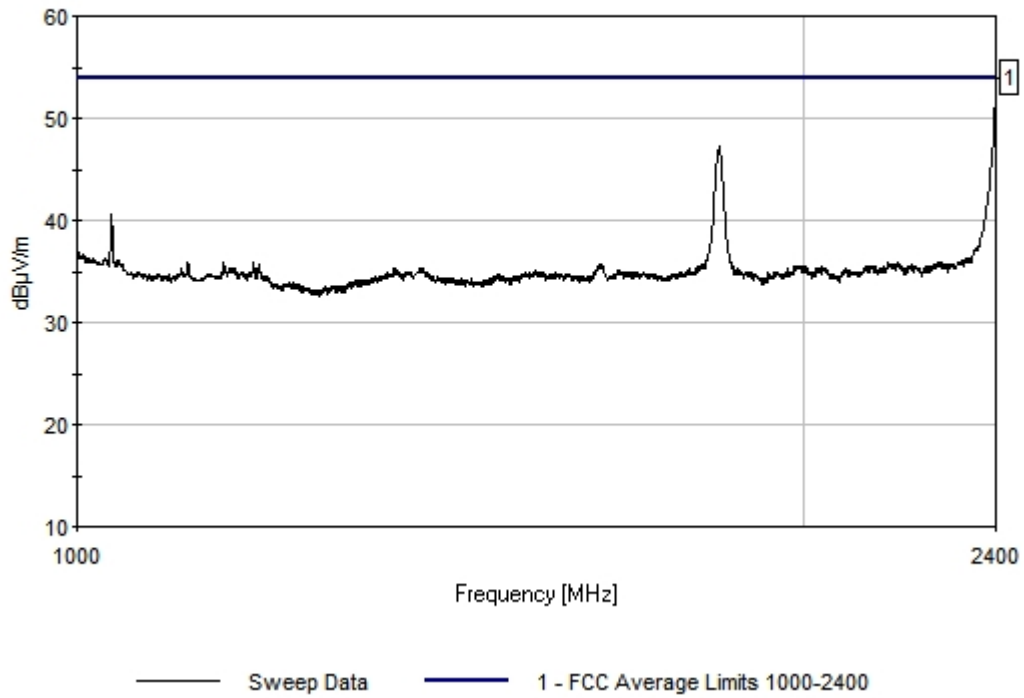



Test Location: EMCE Engineering •44366 S. Grimmer Blvd • Fremont, CA 94538 • 510-490-4307

Customer: **Socket Communications, Inc.**  
 Specification: **FCC Average Limits 1000-2400**  
 Work Order #: **2758**  
 Test Type: **Radiated Scan**  
 Equipment: **SD WLAN**  
 Manufacturer: Socket Communications  
 Model: SDIO WLAN  
 S/N:

Date: 1/31/2008  
 Time: 12:46:03 PM  
 Sequence#: 27  
 Tested By: Bob Cole

**Test Equipment:**

Function	S/N	Calibration Date	Cal Due Date	Asset #
----------	-----	------------------	--------------	---------

**Equipment Under Test (\* = EUT):**

Function	Manufacturer	Model #	S/N
SD WLAN*	Socket Communications	SDIO WLAN	

**Support Devices:**

Function	Manufacturer	Model #	S/N
PDA (Host)	Dell	C22	

**Test Conditions / Notes:**

2462 MHz 1 MHz RBW / 10 Hz VBW 5.5 MBS CCK EUT in SD Extender - Modular
---

**Transducer Legend:**

T1=84125 RF Amps	T2=cable1 18 GHz test
T3=A.H. SAS-200/571 Horn 1 meter	

**Measurement Data:**

Reading listed by margin.

Test Distance: 3 Meters

#	Freq MHz	Rdng dBµV	T1 dB	T2 dB	T3 dB	dB	Dist Table	Corr dBµV/m	Spec dBµV/m	Margin dB	Polar Ant
1	1885.432M	70.4	+55.0	+7.9	+27.1		+0.0	50.4	54.0	-3.6	Vert
2	1878.751M	69.6	+55.0	+7.9	+27.0		+0.0	49.5	54.0	-4.5	Vert
3	1033.202M	64.5	+54.8	+7.0	+23.5		+0.0	40.2	54.0	-13.8	Vert
4	1111.126M	59.6	+54.8	+7.2	+23.6		+0.0	35.6	54.0	-18.4	Vert
5	1694.501M	56.7	+55.0	+7.8	+25.1		+0.0	34.6	54.0	-19.4	Vert
6	1334.734M	56.1	+54.9	+7.4	+24.1		+0.0	32.7	54.0	-21.3	Vert

EMCE Engineering Date: 1/31/2008 Time: 12:46:03 PM Socket Mobile, Inc. WO#: 2758  
FCC Average Limits 1000-2400 Test Distance: 3 Meters Sequence#: 27

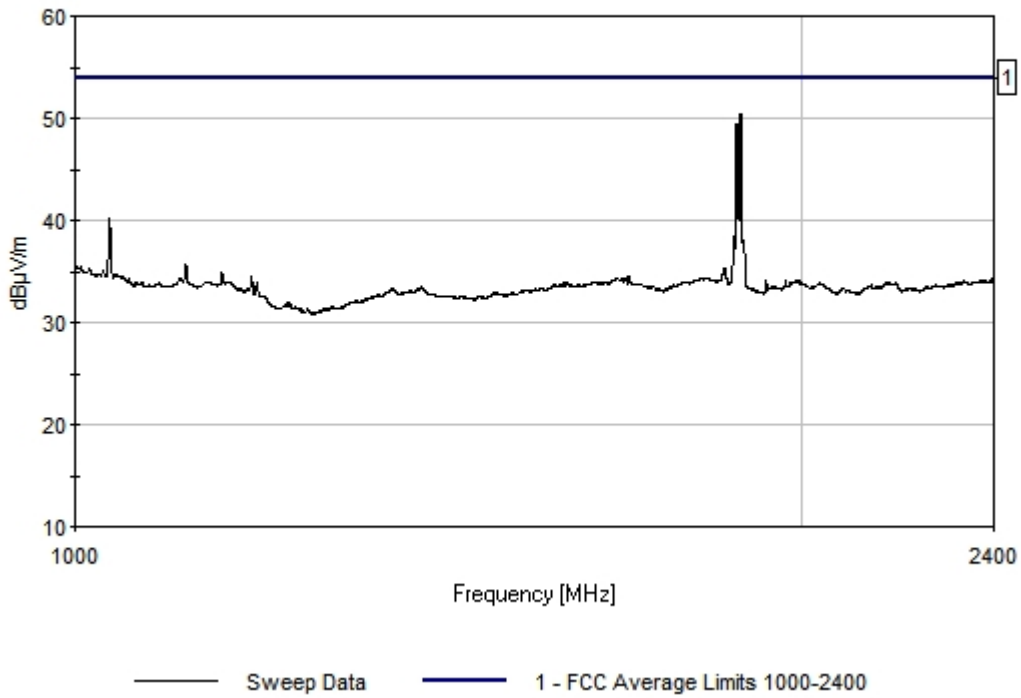

Test Location: EMCE Engineering •44366 S. Grimmer Blvd • Fremont, CA 94538 • 510-490-4307

Customer: **Socket Communications, Inc.**  
 Specification: **FCC Average Limits 1000-2400**  
 Work Order #: **2758**  
 Test Type: **Radiated Scan**  
 Equipment: **SD WLAN**  
 Manufacturer: **Socket Communications**  
 Model: **SDIO WLAN**  
 S/N:

Date: 1/31/2008  
 Time: 12:49:00 PM  
 Sequence#: 28  
 Tested By: Bob Cole

**Test Equipment:**

Function	S/N	Calibration Date	Cal Due Date	Asset #
----------	-----	------------------	--------------	---------

**Equipment Under Test (\* = EUT):**

Function	Manufacturer	Model #	S/N
SD WLAN*	Socket Communications	SDIO WLAN	

**Support Devices:**

Function	Manufacturer	Model #	S/N
PDA (Host)	Dell	C22	

**Test Conditions / Notes:**

2462 MHz 1 MHz RBW / 10 Hz VBW 6 MBS OFDM EUT in SD Extender - Modular
--

**Transducer Legend:**

T1=84125 RF Amps	T2=cable1 18 GHz test
T3=A.H. SAS-200/571 Horn 1 meter	

**Measurement Data:** Reading listed by margin. Test Distance: 3 Meters

#	Freq MHz	Rdng dBµV	T1 dB	T2 dB	T3 dB	Dist dB	Corr dB	Spec dBµV/m	Margin dB	Polar Ant
1	1884.217M	65.9	+55.0	+7.9	+27.1	+0.0	45.9	54.0	-8.1	Vert
2	1033.541M	67.1	+54.8	+7.0	+23.5	+0.0	42.8	54.0	-11.2	Vert
3	2398.078M	55.0	+54.8	+8.8	+29.2	+0.0	38.2	54.0	-15.8	Vert
4	1390.068M	60.2	+54.9	+7.5	+24.2	+0.0	37.0	54.0	-17.0	Vert

EMCE Engineering Date: 1/31/2008 Time: 12:49:00 PM Socket Mobile, Inc. WO#: 2758  
FCC Average Limits 1000-2400 Test Distance: 3 Meters Sequence#: 28

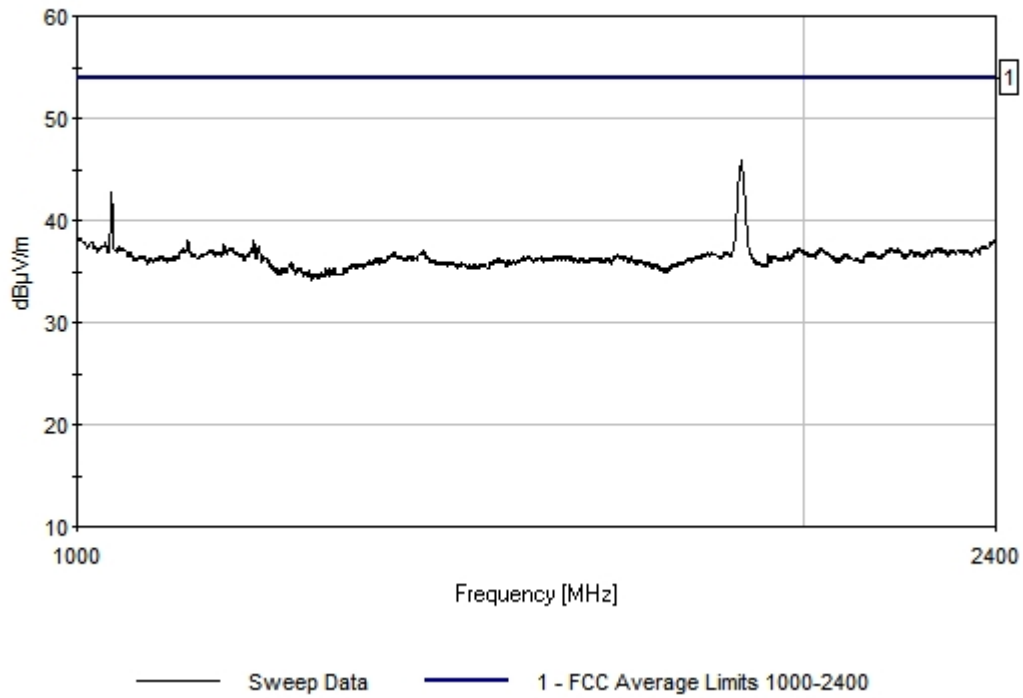

## RADIATED SPURIOUS EMISSIONS

### 2483.5 - 18000 MHz

Test Location: EMCE Engineering •44366 S. Grimmer Blvd • Fremont, CA 94538 • 510-490-4307

Customer: **Socket Communications, Inc.**  
 Specification: **FCC Rad Average Limits 2483.5 - 12750**  
 Work Order #: **2758** Date: 1/31/2008  
 Test Type: **Radiated Scan** Time: 12:29:01 PM  
 Equipment: **SD WLAN** Sequence#: 23  
 Manufacturer: Socket Communications Tested By: Bob Cole  
 Model: SDIO WLAN  
 S/N:

**Test Equipment:**

Function	S/N	Calibration Date	Cal Due Date	Asset #
----------	-----	------------------	--------------	---------

**Equipment Under Test (\* = EUT):**

Function	Manufacturer	Model #	S/N
SD WLAN*	Socket Communications	SDIO WLAN	

**Support Devices:**

Function	Manufacturer	Model #	S/N
PDA (Host)	Dell	C22	

**Test Conditions / Notes:**

2412 MHz 1 MHz RBW / 10 Hz VBW 5.5 MBS CCK EUT in SD Extender - Modular
---

**Transducer Legend:**

T1=84125 RF Amps	T2=A.H. SAS-200/571 Horn 1 meter
T3=cable1 18 GHz test	

#	Freq MHz	Rdng dBµV	Reading listed by margin.			Dist Table	Corr dBµV/m	Spec dBµV/m	Margin dB	Polar Ant
			T1 dB	T2 dB	T3 dB					
1	4823.338M	58.9	+54.7	+34.8	+9.9	+0.0	48.9	54.0	-5.1	Vert
2	17976.930M	38.5	+54.6	+44.8	+16.9	+0.0	45.6	54.0	-8.4	Vert
3	3731.247M	57.0	+54.8	+32.0	+9.6	+0.0	43.8	54.0	-10.2	Vert
4	17486.990M	38.4	+54.6	+43.9	+16.1	+0.0	43.8	54.0	-10.2	Vert
5	3399.916M	57.8	+54.9	+30.8	+9.4	+0.0	43.1	54.0	-10.9	Vert
6	3038.555M	57.9	+54.9	+30.3	+9.3	+0.0	42.6	54.0	-11.4	Vert
7	2697.214M	57.2	+55.0	+29.7	+9.1	+0.0	41.0	54.0	-13.0	Vert
8	16436.940M	38.8	+54.6	+41.1	+14.7	+0.0	40.0	54.0	-14.0	Vert
9	5499.013M	50.2	+54.8	+34.9	+9.0	+0.0	39.3	54.0	-14.7	Vert
10	14520.030M	39.4	+54.8	+41.5	+12.3	+0.0	38.4	54.0	-15.6	Vert

EMCE Engineering Date: 1/31/2008 Time: 12:29:01 PM Socket Mobile, Inc. WO#: 2758  
FCC Rad Average Limits 2483.5 - 12750 Test Distance: 3 Meters Sequence#: 23

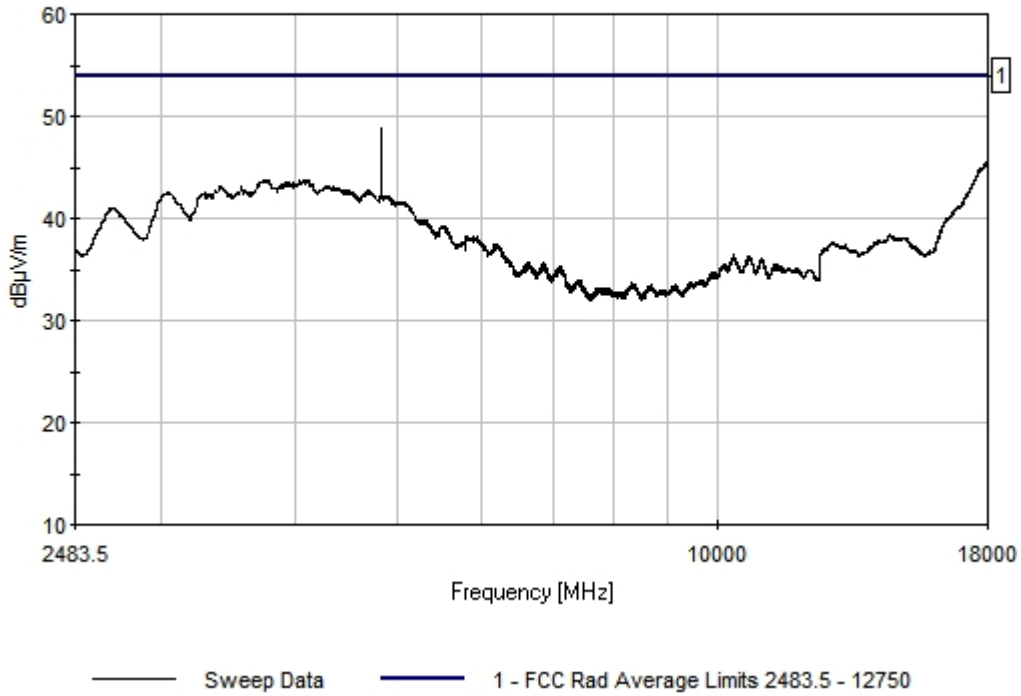

Test Location: EMCE Engineering •44366 S. Grimmer Blvd • Fremont, CA 94538 • 510-490-4307

Customer: **Socket Communications, Inc.**  
 Specification: **FCC Rad Average Limits 2483.5 - 12750**  
 Work Order #: **2758** Date: 1/31/2008  
 Test Type: **Radiated Scan** Time: 11:40:00 AM  
 Equipment: **SD WLAN** Sequence#: 18  
 Manufacturer: Socket Communications Tested By: Bob Cole  
 Model: SDIO WLAN  
 S/N:

**Test Equipment:**

Function	S/N	Calibration Date	Cal Due Date	Asset #
----------	-----	------------------	--------------	---------

**Equipment Under Test (\* = EUT):**

Function	Manufacturer	Model #	S/N
SD WLAN*	Socket Communications	SDIO WLAN	

**Support Devices:**

Function	Manufacturer	Model #	S/N
PDA (Host)	Dell	C22	

**Test Conditions / Notes:**

2412 MHz 1 MHz RBW / 10 Hz VBW 6 MBS OFDM EUT in SD Extender - Modular
--

**Transducer Legend:**

T1=84125 RF Amps	T2=A.H. SAS-200/571 Horn 1 meter
T3=cable1 18 GHz test	

**Measurement Data:**

Reading listed by margin.

Test Distance: 3 Meters

#	Freq MHz	Rdng dBµV	T1 dB	T2 dB	T3 dB	dB	Dist Table	Corr dBµV/m	Spec dBµV/m	Margin dB	Polar Ant
1	4824.339M	59.3	+54.7	+34.8	+9.9		+0.0	49.3	54.0	-4.7	Vert
2	17971.920M	38.3	+54.6	+44.8	+16.9		+0.0	45.4	54.0	-8.6	Vert
3	3732.248M	58.1	+54.8	+32.0	+9.6		+0.0	44.9	54.0	-9.1	Vert
4	3400.917M	58.8	+54.9	+30.8	+9.4		+0.0	44.1	54.0	-9.9	Vert
5	17486.990M	38.3	+54.6	+43.9	+16.1		+0.0	43.7	54.0	-10.3	Vert
6	16463.970M	38.7	+54.6	+41.2	+14.7		+0.0	40.0	54.0	-14.0	Vert
7	14512.020M	39.2	+54.8	+41.5	+12.3		+0.0	38.2	54.0	-15.8	Vert
8	14485.990M	39.1	+54.8	+41.5	+12.3		+0.0	38.1	54.0	-15.9	Vert
9	5501.015M	48.4	+54.8	+34.9	+9.0		+0.0	37.5	54.0	-16.5	Vert
10	12834.340M	39.4	+55.1	+41.3	+11.1		+0.0	36.7	54.0	-17.3	Vert

EMCE Engineering Date: 1/31/2008 Time: 11:40:00 AM Socket Mobile, Inc. WO#: 2758  
FCC Rad Average Limits 2483.5 - 12750 Test Distance: 3 Meters Sequence#: 18

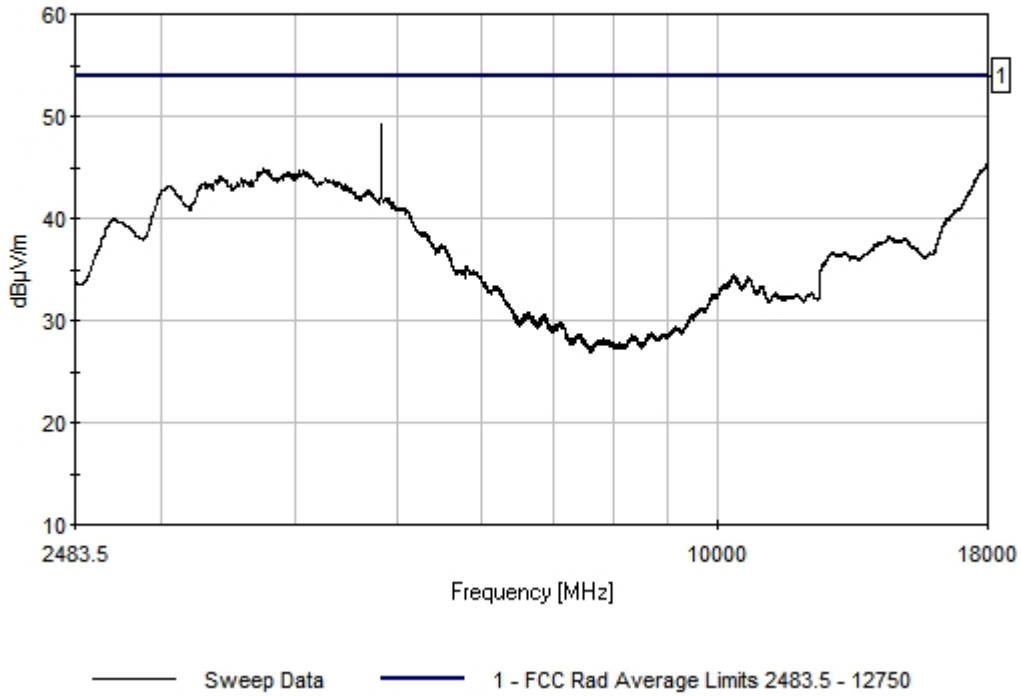



Test Location: EMCE Engineering •44366 S. Grimmer Blvd • Fremont, CA 94538 • 510-490-4307

Customer: **Socket Communications, Inc.**  
 Specification: **FCC Rad Average Limits 2483.5 - 12750**  
 Work Order #: **2758**  
 Test Type: **Radiated Scan**  
 Equipment: **SD WLAN**  
 Manufacturer: **Socket Communications**  
 Model: **SDIO WLAN**  
 S/N:

Date: 1/31/2008  
 Time: 12:20:51 PM  
 Sequence#: 22  
 Tested By: Bob Cole

**Test Equipment:**

Function	S/N	Calibration Date	Cal Due Date	Asset #
----------	-----	------------------	--------------	---------

**Equipment Under Test (\* = EUT):**

Function	Manufacturer	Model #	S/N
SD WLAN*	Socket Communications	SDIO WLAN	

**Support Devices:**

Function	Manufacturer	Model #	S/N
PDA (Host)	Dell	C22	

**Test Conditions / Notes:**

2437 MHz 1 MHz RBW / 10 Hz VBW 5.5 MBS CCK EUT in SD Extender - Modular
---

**Transducer Legend:**

T1=84125 RF Amps	T2=A.H. SAS-200/571 Horn 1 meter
T3=cable1 18 GHz test	

**Measurement Data:**

Reading listed by margin.

Test Distance: 3 Meters

#	Freq MHz	Rdng dBµV	T1 dB	T2 dB	T3 dB	dB	Dist Table	Corr dBµV/m	Spec dBµV/m	Margin dB	Polar Ant
1	4873.388M	60.1	+54.7	+34.9	+10.0		+0.0	50.3	54.0	-3.7	Vert
2	17971.920M	38.5	+54.6	+44.8	+16.9		+0.0	45.6	54.0	-8.4	Vert
3	3731.247M	57.1	+54.8	+32.0	+9.6		+0.0	43.9	54.0	-10.1	Vert
4	17494.000M	38.5	+54.6	+43.9	+16.1		+0.0	43.9	54.0	-10.1	Vert
5	3401.918M	58.0	+54.9	+30.8	+9.4		+0.0	43.3	54.0	-10.7	Vert
6	3037.554M	57.9	+54.9	+30.3	+9.3		+0.0	42.6	54.0	-11.4	Vert
7	2696.213M	57.2	+55.0	+29.7	+9.1		+0.0	41.0	54.0	-13.0	Vert
8	16489.990M	38.6	+54.6	+41.3	+14.8		+0.0	40.1	54.0	-13.9	Vert
9	5501.015M	50.2	+54.8	+34.9	+9.0		+0.0	39.3	54.0	-14.7	Vert
10	14498.000M	39.3	+54.8	+41.5	+12.3		+0.0	38.3	54.0	-15.7	Vert

EMCE Engineering Date: 1/31/2008 Time: 12:20:51 PM Socket Mobile, Inc. WO#: 2758  
FCC Rad Average Limits 2483.5 - 12750 Test Distance: 3 Meters Sequence#: 22

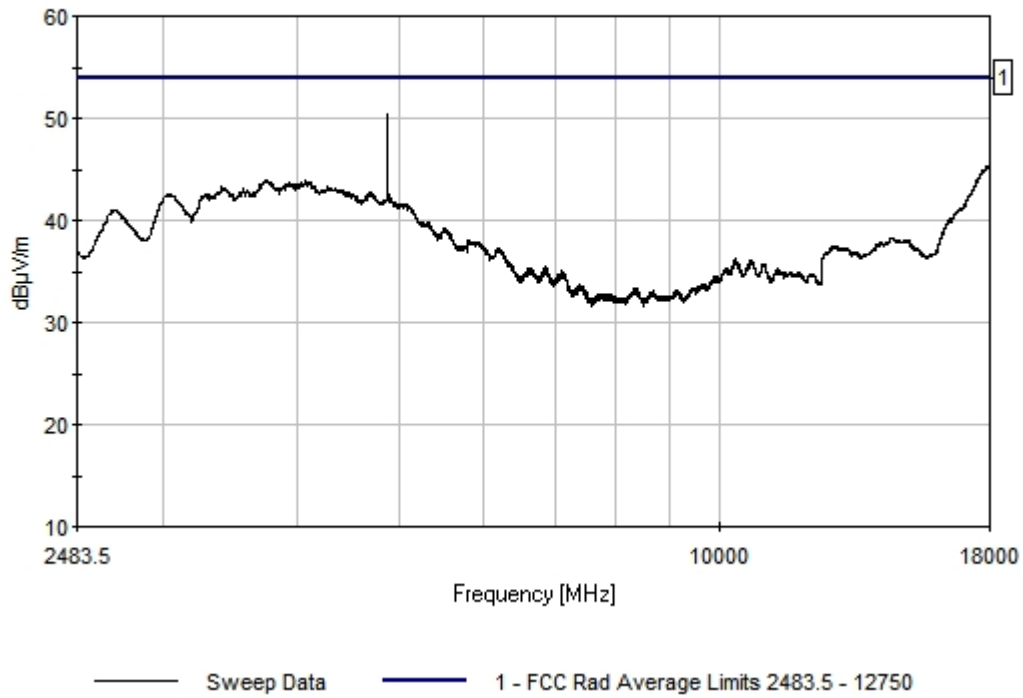

Test Location: EMCE Engineering •44366 S. Grimmer Blvd • Fremont, CA 94538 • 510-490-4307

Customer: **Socket Communications, Inc.**  
 Specification: **FCC Rad Average Limits 2483.5 - 12750**  
 Work Order #: **2758** Date: 1/31/2008  
 Test Type: **Radiated Scan** Time: 11:56:46 AM  
 Equipment: **SD WLAN** Sequence#: 19  
 Manufacturer: Socket Communications Tested By: Bob Cole  
 Model: SDIO WLAN  
 S/N:

**Test Equipment:**

Function	S/N	Calibration Date	Cal Due Date	Asset #
----------	-----	------------------	--------------	---------

**Equipment Under Test (\* = EUT):**

Function	Manufacturer	Model #	S/N
SD WLAN*	Socket Communications	SDIO WLAN	

**Support Devices:**

Function	Manufacturer	Model #	S/N
PDA (Host)	Dell	C22	

**Test Conditions / Notes:**

2437 MHz 1 MHz RBW / 10 Hz VBW 6 MBS OFDM EUT in SD Extender - Modular
--

**Transducer Legend:**

T1=84125 RF Amps	T2=A.H. SAS-200/571 Horn 1 meter
T3=cable 1 18 GHz test	

**Measurement Data:**

Reading listed by margin.

Test Distance: 3 Meters

#	Freq MHz	Rdng dBµV	T1 dB	T2 dB	T3 dB	Dist dB	Corr dBµV/m	Spec dBµV/m	Margin dB	Polar Ant
1	4873.388M	60.0	+54.7	+34.9	+10.0	+0.0	50.2	54.0	-3.8	Vert
2	17971.920M	38.4	+54.6	+44.8	+16.9	+0.0	45.5	54.0	-8.5	Vert
3	3731.247M	57.6	+54.8	+32.0	+9.6	+0.0	44.4	54.0	-9.6	Vert
4	17487.990M	38.4	+54.6	+43.9	+16.1	+0.0	43.8	54.0	-10.2	Vert
5	3400.917M	58.4	+54.9	+30.8	+9.4	+0.0	43.7	54.0	-10.3	Vert
6	3040.557M	58.3	+54.9	+30.3	+9.3	+0.0	43.0	54.0	-11.0	Vert
7	16489.990M	38.5	+54.6	+41.3	+14.8	+0.0	40.0	54.0	-14.0	Vert
8	5499.013M	49.6	+54.8	+34.9	+9.0	+0.0	38.7	54.0	-15.3	Vert
9	14510.010M	39.2	+54.8	+41.5	+12.3	+0.0	38.2	54.0	-15.8	Vert
10	14477.980M	39.1	+54.8	+41.5	+12.3	+0.0	38.1	54.0	-15.9	Vert

EMCE Engineering Date: 1/31/2008 Time: 11:56:46 AM Socket Mobile, Inc. WO#: 2758  
FCC Rad Average Limits 2483.5 - 12750 Test Distance: 3 Meters Sequence#: 19

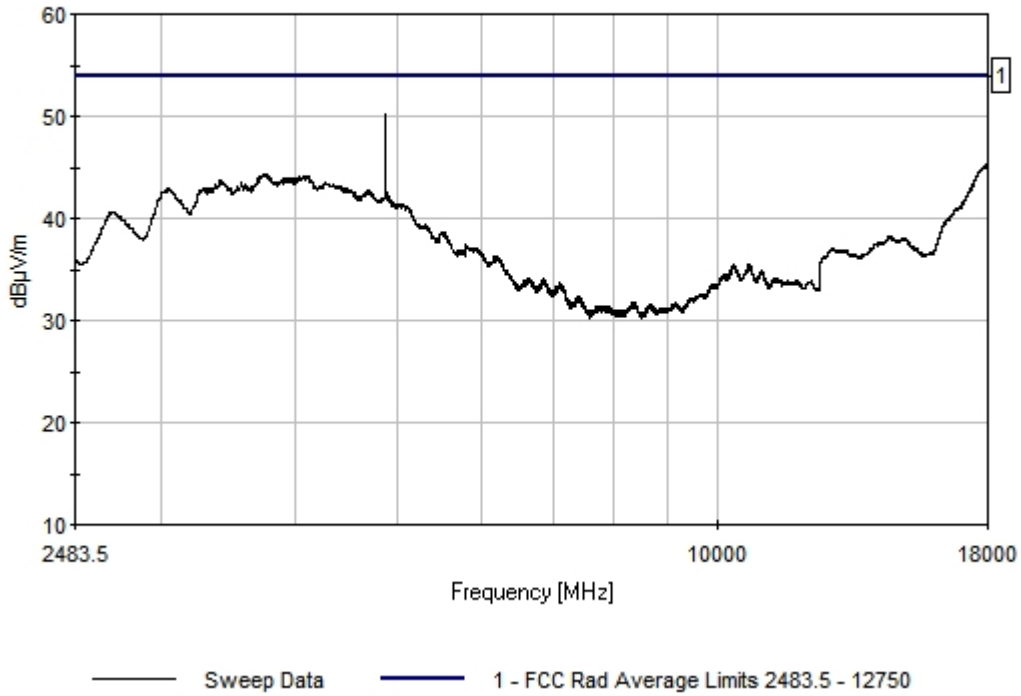

Test Location: EMCE Engineering •44366 S. Grimmer Blvd • Fremont, CA 94538 • 510-490-4307

Customer: **Socket Communications, Inc.**  
 Specification: **FCC Rad Average Limits 2483.5 - 12750**  
 Work Order #: **2758** Date: 1/31/2008  
 Test Type: **Radiated Scan** Time: 12:12:56 PM  
 Equipment: **SD WLAN** Sequence#: 21  
 Manufacturer: Socket Communications Tested By: Bob Cole  
 Model: SDIO WLAN  
 S/N:

**Test Equipment:**

Function	S/N	Calibration Date	Cal Due Date	Asset #
----------	-----	------------------	--------------	---------

**Equipment Under Test (\* = EUT):**

Function	Manufacturer	Model #	S/N
SD WLAN*	Socket Communications	SDIO WLAN	

**Support Devices:**

Function	Manufacturer	Model #	S/N
PDA (Host)	Dell	C22	

**Test Conditions / Notes:**

2462 MHz 1 MHz RBW / 10 Hz VBW 5.5 MBS CCK EUT in SD Extender - Modular
---

**Transducer Legend:**

T1=84125 RF Amps	T2=A.H. SAS-200/571 Horn 1 meter
T3=cable1 18 GHz test	

**Measurement Data:**

Reading listed by margin.

Test Distance: 3 Meters

#	Freq MHz	Rdng dB $\mu$ V	T1 dB	T2 dB	T3 dB	dB	Dist Table	Corr dB $\mu$ V/m	Spec dB $\mu$ V/m	Margin dB	Polar Ant
1	4923.438M	58.3	+54.7	+35.0	+10.0		+0.0	48.6	54.0	-5.4	Vert
2	17971.920M	38.4	+54.6	+44.8	+16.9		+0.0	45.5	54.0	-8.5	Vert
3	3731.247M	57.3	+54.8	+32.0	+9.6		+0.0	44.1	54.0	-9.9	Vert
4	17486.990M	38.4	+54.6	+43.9	+16.1		+0.0	43.8	54.0	-10.2	Vert
5	3403.920M	58.1	+54.9	+30.8	+9.4		+0.0	43.4	54.0	-10.6	Vert
6	3038.555M	58.0	+54.9	+30.3	+9.3		+0.0	42.7	54.0	-11.3	Vert
7	2694.211M	57.1	+55.0	+29.7	+9.1		+0.0	40.9	54.0	-13.1	Vert
8	16490.990M	38.6	+54.6	+41.3	+14.8		+0.0	40.1	54.0	-13.9	Vert
9	5498.012M	49.9	+54.8	+34.9	+9.0		+0.0	39.0	54.0	-15.0	Vert
10	14507.010M	39.3	+54.8	+41.5	+12.3		+0.0	38.3	54.0	-15.7	Vert

EMCE Engineering Date: 1/31/2008 Time: 12:12:56 PM Socket Mobile, Inc. WO#: 2758  
FCC Rad Average Limits 2483.5 - 12750 Test Distance: 3 Meters Sequence#: 21

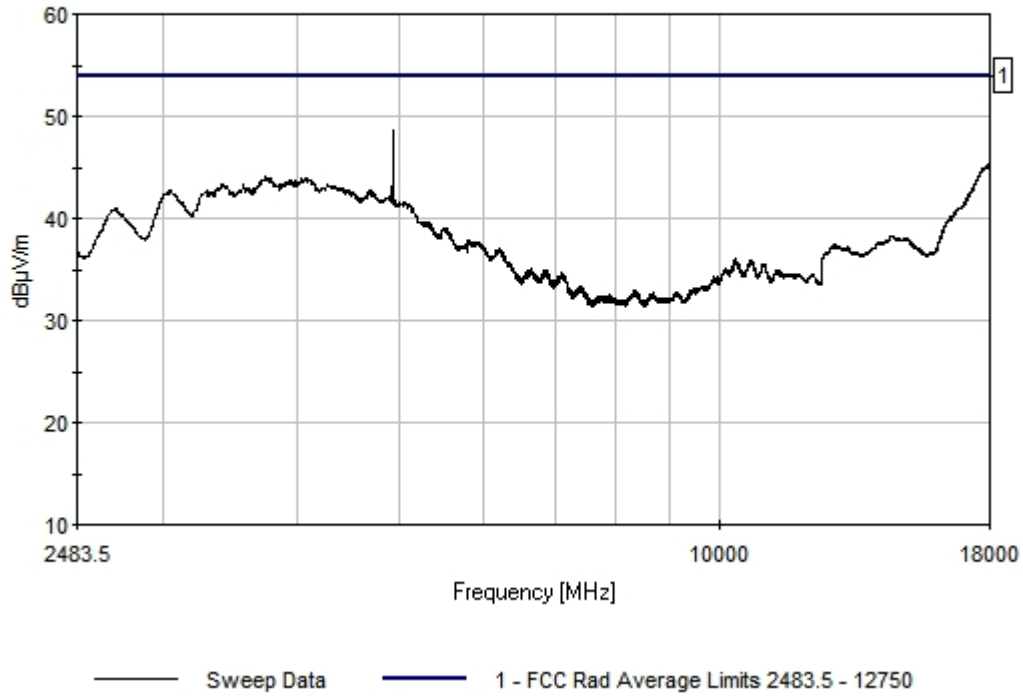

Test Location: EMCE Engineering •44366 S. Grimmer Blvd • Fremont, CA 94538 • 510-490-4307

Customer: **Socket Communications, Inc.**  
 Specification: **FCC Rad Average Limits 2483.5 - 12750**  
 Work Order #: **2758** Date: 1/31/2008  
 Test Type: **Radiated Scan** Time: 12:04:46 PM  
 Equipment: **SD WLAN** Sequence#: 20  
 Manufacturer: Socket Communications Tested By: Bob Cole  
 Model: SDIO WLAN  
 S/N:

**Test Equipment:**

Function	S/N	Calibration Date	Cal Due Date	Asset #
----------	-----	------------------	--------------	---------

**Equipment Under Test (\* = EUT):**

Function	Manufacturer	Model #	S/N
SD WLAN*	Socket Communications	SDIO WLAN	

**Support Devices:**

Function	Manufacturer	Model #	S/N
PDA (Host)	Dell	C22	

**Test Conditions / Notes:**

2462 MHz 1 MHz RBW / 10 Hz VBW 6 MBS OFDM EUT in SD Extender - Modular
--

**Transducer Legend:**

T1=84125 RF Amps	T2=A.H. SAS-200/571 Horn 1 meter
T3=cable1 18 GHz test	

**Measurement Data:**

Reading listed by margin.

Test Distance: 3 Meters

#	Freq MHz	Rdng dB $\mu$ V	T1 dB	T2 dB	T3 dB	dB	Dist Table	Corr dB $\mu$ V/m	Spec dB $\mu$ V/m	Margin dB	Polar Ant
1	4923.438M	58.0	+54.7	+35.0	+10.0		+0.0	48.3	54.0	-5.7	Vert
2	17971.920M	38.4	+54.6	+44.8	+16.9		+0.0	45.5	54.0	-8.5	Vert
3	3732.248M	57.4	+54.8	+32.0	+9.6		+0.0	44.2	54.0	-9.8	Vert
4	17486.990M	38.4	+54.6	+43.9	+16.1		+0.0	43.8	54.0	-10.2	Vert
5	3399.916M	58.2	+54.9	+30.8	+9.4		+0.0	43.5	54.0	-10.5	Vert
6	2695.212M	57.0	+55.0	+29.7	+9.1		+0.0	40.8	54.0	-13.2	Vert
7	16489.990M	38.5	+54.6	+41.3	+14.8		+0.0	40.0	54.0	-14.0	Vert
8	5498.012M	49.8	+54.8	+34.9	+9.0		+0.0	38.9	54.0	-15.1	Vert
9	14521.030M	39.3	+54.8	+41.5	+12.3		+0.0	38.3	54.0	-15.7	Vert
10	14482.990M	39.1	+54.8	+41.5	+12.3		+0.0	38.1	54.0	-15.9	Vert

EMCE Engineering Date: 1/31/2008 Time: 12:04:46 PM Socket Mobile, Inc. WO#: 2758  
FCC Rad Average Limits 2483.5 - 12750 Test Distance: 3 Meters Sequence#: 20

