

FCC TEST REPORT

according to

FCC Rules and Regulations

Part 15 Subpart C

Applicant	Socket Communications, Inc.
Address	37400 Central Court Newark, CA 94560 U.S.A.
Equipment	KwikBlue4 Class 1 BC04 Bluetooth Module
Model No.	KwikBlue4-1
FCC ID	LUBBTM-4
Trade Name	Socket

Laboratory Accreditation



1332

- The test result refers exclusively to the test presented test model / sample.,
- Without written approval of **Exclusive Certification Corp.** the test report shall not be reproduced except in full.
- The EUT is also considered as a kind of computer peripheral, because the connection to computer is necessary for typical use. It has been verified to comply with the requirements of FCC Part 15, Subpart B, Class B (DoC). The test report has been issued separately.

Contents

CERTIFICATE OF COMPLIANCE.....	3
1. Report of Measurements and Examinations	4
1.1 List of Measurements and Examinations	4
2. Test Configuration of Equipment under Test	5
2.1 Feature of Equipment under Test	5
2.2 RF Module Specifications	5
2.3 Test Mode and Test Software.....	6
2.4 Description of Test System	6
2.5 Connection Diagram of Test System	7
2.6 General Information of Test	8
2.7 History of this test report	8
3. Antenna Requirements	9
3.1 Standard Applicable	9
3.2 Antenna Construction and Directional Gain	9
4. Test of Conducted Emission	10
4.1 Test Limit	10
4.2 Test Procedures	10
4.3 Typical Test Setup	11
4.4 Measurement equipment	11
4.5 Test Result and Data.....	12
5. Test of Radiated Emission	19
5.1 Test Limit	19
5.2 Test Procedures	20
5.3 Typical Test Setup.....	21
5.4 Measurement equipment	21
5.5 Test Result and Data.....	22
5.6 Channel Carrier Frequencies Separation	33
5.7 20dB Bandwidth Measurement Data	36
5.8 Dwell Time	39
5.9 Number of Hopping Channels.....	43
5.10 Peak Output Power Measurement Data	45
5.11 Band Edges Measurement Data	48
Appendix A. Photographs of EUT.....	A1 ~ A2

CERTIFICATE OF COMPLIANCE

according to

FCC Rules and Regulations

Part 15 Subpart C

Applicant	Socket Communications, Inc.
Address	37400 Central Court Newark, CA 94560 U.S.A.
Equipment	KwikBlue4 Class 1 BC04 Bluetooth Module
Model No.	KwikBlue4-1
FCC ID	LUBBTM-4

I HEREBY CERTIFY THAT :

The measurements shown in this test report were made in accordance with the procedures given in **ANSI C63.4**. The equipment was **passed** the test performed according to **FCC Rules and Regulations Part 15 Subpart C (2003)**. The test was carried out on Jun. 07, 2005 at *Exclusive Certification Corp.*

Signature

Anson Chou / Manager

1. Report of Measurements and Examinations

1.1 List of Measurements and Examinations

FCC Rule	Description of Test	Result
15.203	. Antenna Requirement	Pass
15.207	. Conducted Emission	Pass
15.209	. Radiated Emission	Pass
15.247(a)(1)(iii)	. Channel Carrier Frequencies Separation	Pass
15.247(a)(1)	. 20dB Bandwidth Measurement	Pass
15.247(a)(1)(iii)	. Dwell Time	Pass
15.247(b)(1)	. Number of Hopping Channels	Pass
15.247(b)	. Peak Output Power Measurement Data	Pass
15.247(c)	. Band Edges Measurement Data	Pass
15.247(d)	. Power Spectral Density Measurement Data	Pass

Test engineer:

Jerry

2. Test Configuration of Equipment under Test

2.1 Feature of Equipment under Test

Power Level +15 dBm Max.
Program Memory 8 Mbits (512k x 16 bits) Flash
RAM 32k bytes x 16 bits
Reference Oscillator Built-in
Sub Clock Oscillator Built-in
Audio Interface PCM A-Law, μ -Law (CVSD)
Serial Data Interface UART (BCSP of H:4)
USB Interface USB 1.1 (OHCI and UHCI)
Physical Connection Board-to-board connection – solder down

2.2 RF Module Specifications

Operating Frequency 2400 MHz to 2483.5 MHz
Carrier Spacing 1.0 MHz
Channel 79
Duplexing TDD
Symbol Rate (Std data rate) 1 Mbps
Symbol Rate (EDR data rate) 2 & 3 Mbps
Modulation Method (Std data rate) GFSK BbT = 0.5
Modulation Method (EDR data rate) DQPSK & D8PSK
Reference Oscillator 16 MHz (built in)
RF input and output impedance Nominal 50 ohm

2.3 Test Mode and Test Software

The following test mode and test software was performed for conduction and radiation test:

- 802.11b (CH LO: 2412MHz) • 802.11b (CH MID: 2437MHz) • 802.11b (CH HI: 2462MHz)
- 802.11g (CH LO: 2412MHz) • 802.11g (CH MID: 2437MHz) • 802.11g (CH HI: 2462MHz)
- An executive programs, "Internet Explorer.EXE" Application under WIN XP.

2.4 Description of Test System

Device	Manufacturer	Model No.	Description
PC	IBM	IGV	Power Cable, Adapter Unshielding 1.8 m
Monitor	SlimAGE	510A	Power Cable, Adapter Unshielding 1.8 m Data Cable, VGA, shielding 1.35 m
Keyboard	IBM	KB-0225	Data Cable, PS2 shielding 1.85 m
Mouse	IBM	MO28VO	Data Cable, USB shielding 1.85 m
Printer	HP	Desk Jet400	Power Cable, Adapter Unshielding 1.8 m Data Cable, PRINT, shielding 1.6 m
Notebook	DELL	510m	Power Cable, Adapter Unshielding 1.8 m

Use Cable:

Cable	Description
USB	Shielding, 1.5m
RS232	Shielding, 0.8m
Floating 25 Pin	Shielding, 1.35m

2.5 Connection Diagram of Test System

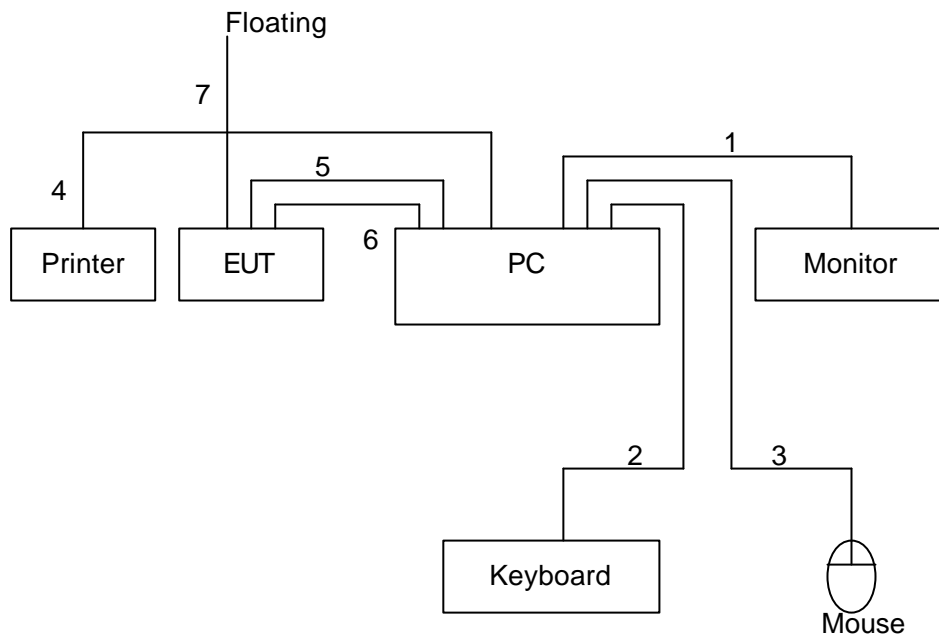

1. The I/O cable is connected from PC to the Monitor.
2. The I/O cable is connected from PC to the Keyboard.
3. The I/O cable is connected from PC to the Mouse.
4. The I/O cable is connected from PC to the Printer.
5. The USB cable is connected from PC to the EUT.
6. The RS232 cable is connected from PC to the EUT.
7. These 25 Pin cables are floating.

2.6 General Information of Test

Test Site:	Exclusive Certification Corp. 4F-2, No. 28, Lane 78, Xing-Ai Rd. Nei-hu, Taipei City 114 Taiwan R.O.C.
Test Site Location (OATS1-SD):	No.68-1, Shihbachongsi, shihding Township, Taipei County 223, Taiwan, R.O.C.
Test Voltage:	AC 120V/ 60Hz for PC
Test in Compliance with:	ANSI C63.4-2003 FCC Part 15 Subpart C
Frequency Range Investigated:	Conducted: from 150kHz to 30 MHz Radiation: from 30 MHz to 24620MHz
Test Distance:	The test distance of radiated emission from antenna to EUT is 3 M.

2.7 History of this test report

ORIGINAL.

3. Antenna Requirements

3.1 Standard Applicable

For intentional device, according to FCC 47 CFR Section 15.203, an intentional radiator shall be designed to ensure that no antenna other than that furnished by the responsible party shall be used with the device.

And according to FCC 47 CFR Section 15.247 (b), if transmitting antennas of directional gain greater than 6dBi are used, the power shall be reduced by the amount in dB that the directional gain of the antenna exceeds 6dBi.

3.2 Antenna Construction and Directional Gain

Antenna type: The antenna is designed to be permanently on PCB, No
Consideration of replacement.

Antenna Gain: 0 dBi

4. Test of Conducted Emission

4.1 Test Limit

Conducted Emissions were measured from 150 kHz to 30 MHz with a bandwidth of 9 KHz on the 115 VAC power and return leads of the EUT according to the methods defined in ANSI C63.4-2003 Section 3.1. The EUT was placed on a nonmetallic stand in a shielded room 0.8 meters above the ground plane as shown in section 4.2. The interface cables and equipment positioning were varied within limits of reasonable applications to determine the position produced maximum conducted emissions.

Frequency (MHz)	Quasi Peak (dB μ V)	Average (dB μ V)
0.15 – 0.5	66-56*	56-46*
0.5 – 5.0	56	46
5.0 – 30.0	60	50

4.2 Test Procedures

- a. The EUT was placed 0.4 meter from the conducting wall of the shielding room was kept at least 80 centimeters from any other grounded conducting surface.
- b. Connect EUT to the power mains through a line impedance stabilization network (LISN).
- c. All the support units are connecting to the other LISN.
- d. The LISN provides 50 ohm coupling impedance for the measuring instrument.
- e. The FCC states that a 50 ohm, 50 micro-henry LISN should be used.
- f. Both sides of AC line were checked for maximum conducted interference.
- g. The frequency range from 150 kHz to 30 MHz was searched.
- h. Set the test-receiver system to Peak Detect Function and Specified Bandwidth with Maximum Hold Mode.

4.3 Typical Test Setup

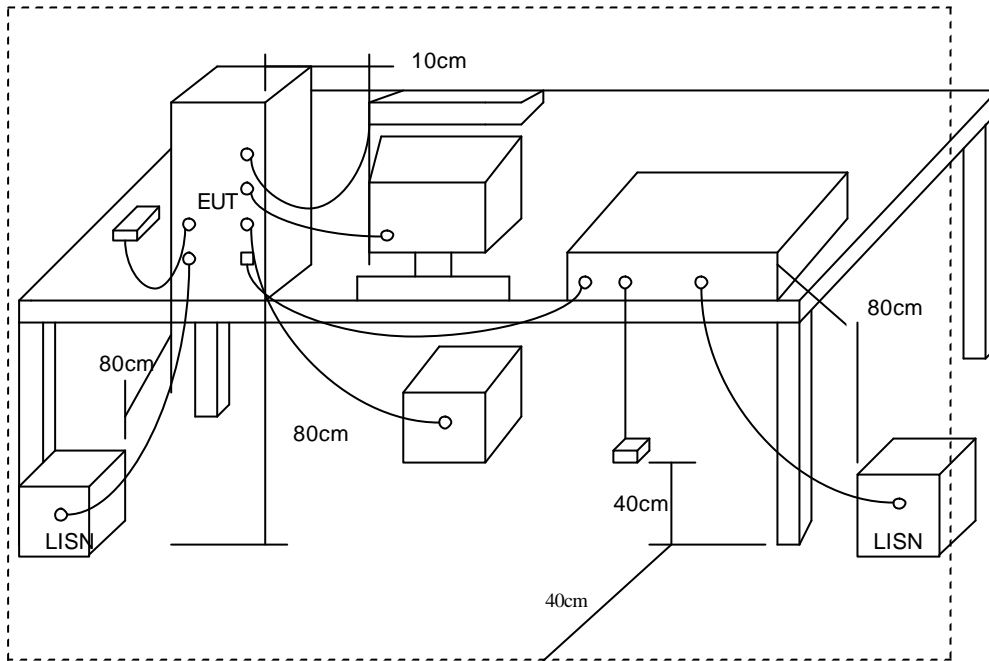

4.4 Measurement equipment

Instrument/Ancillary	Type	Manufacturer	Valid Date.
Receiver	SCR3501	Schaffner	2005/11/03
LISN	NNB-2/16Z	ROLF HEINE	2006/05/01
LISN	ROLF HEINE	NNB-2/16Z	2006/03/30

4.5 Test Result and Data

EUT : Kwik Blue4-1
 Power : AC120V
 Test Mode : CH 0
 Memo :

Pol/Phase : NEUTRAL
 Temperature : 26 °C
 Humidity : 58 %

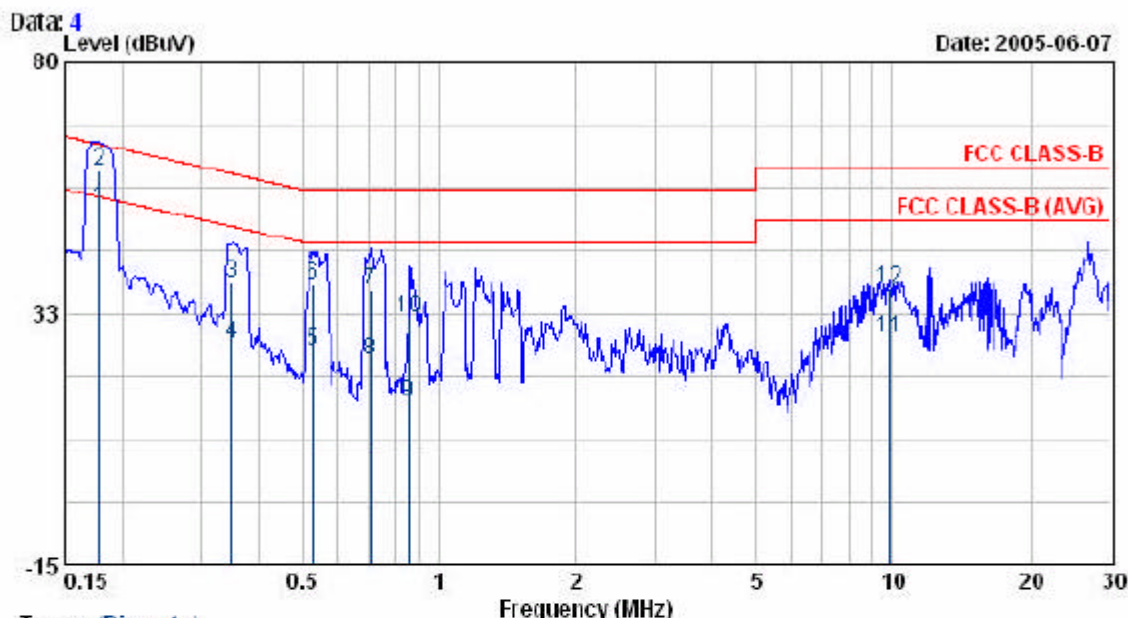

Trace: (Discrete)

Freq	Read Level	Factor	Level	Limit	Over Limit	Remark
MHz	dBuV	dB	dBuV	dBuV	dBuV	
0.18	52.37	0.13	52.50	54.58	-2.07	AVERAGE
0.18	59.31	0.13	59.44	64.58	-5.13	QP
0.35	38.03	0.34	38.37	59.00	-20.63	QP
0.35	26.37	0.34	26.71	49.00	-22.29	AVERAGE
0.53	24.84	0.37	25.21	46.00	-20.79	AVERAGE
0.53	37.50	0.37	37.87	56.00	-18.13	QP
0.71	36.48	0.34	36.82	56.00	-19.18	QP
0.71	23.22	0.34	23.56	46.00	-22.44	AVERAGE
0.86	15.46	0.32	15.78	46.00	-30.22	AVERAGE
0.86	31.40	0.32	31.72	56.00	-24.28	QP
9.89	27.61	0.30	27.91	50.00	-22.09	AVERAGE
9.89	36.91	0.30	37.11	60.00	-22.89	QP

Remarks: 1. Level = Read Level + Factor
 2. Factor = LISN(ISN) Factor + Cable Loss

EVT : Kwik Blue4-1
 Power : AC120V
 Test Mode : CH 0
 Memo :

Pol/Phase : LINE
 Temperature : 26 °C
 Humidity : 58 %

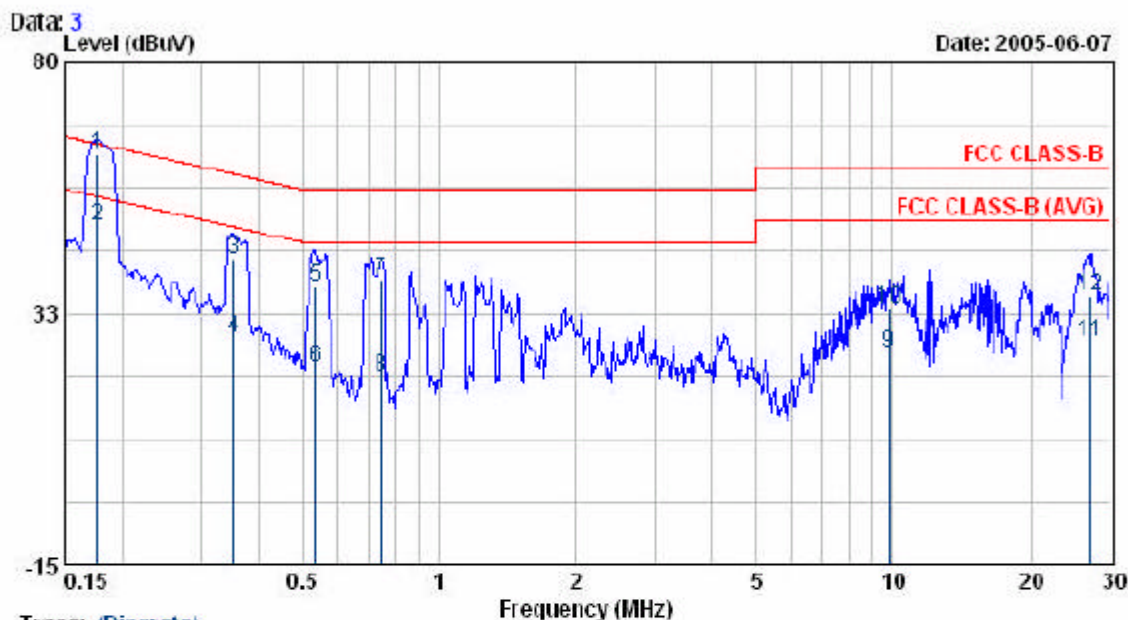

Trace: (Discrete)

Freq	Read Level	Factor	Level	Limit	Over Limit	Remark
MHz	dBuV	dB	dBuV	dBuV	dBuV	
0.18	62.15	0.34	62.49	64.65	-2.17	QP
0.18	48.65	0.34	48.99	54.65	-5.67	AVERAGE
0.35	42.32	0.54	42.86	58.92	-16.06	QP
0.35	27.17	0.54	27.71	48.92	-21.21	AVERAGE
0.54	36.86	0.57	37.43	56.00	-18.57	QP
0.54	21.63	0.57	22.20	46.00	-23.80	AVERAGE
0.75	38.25	0.53	38.78	56.00	-17.22	QP
0.75	19.99	0.53	20.52	46.00	-25.48	AVERAGE
9.83	24.48	0.60	25.08	50.00	-24.92	AVERAGE
9.83	32.74	0.60	33.34	60.00	-26.66	QP
26.99	26.23	0.72	26.95	50.00	-23.05	AVERAGE
26.99	35.16	0.72	35.88	60.00	-24.12	QP

Remarks: 1. Level = Read Level + Factor
 2. Factor = LISN(ISN) Factor + Cable Loss

EUT : Kwik Blue4-1
 Power : AC120V
 Test Mode : CH 39
 Memo :

Pol/Phase : NEUTRAL
 Temperature : 26 °C
 Humidity : 58 %

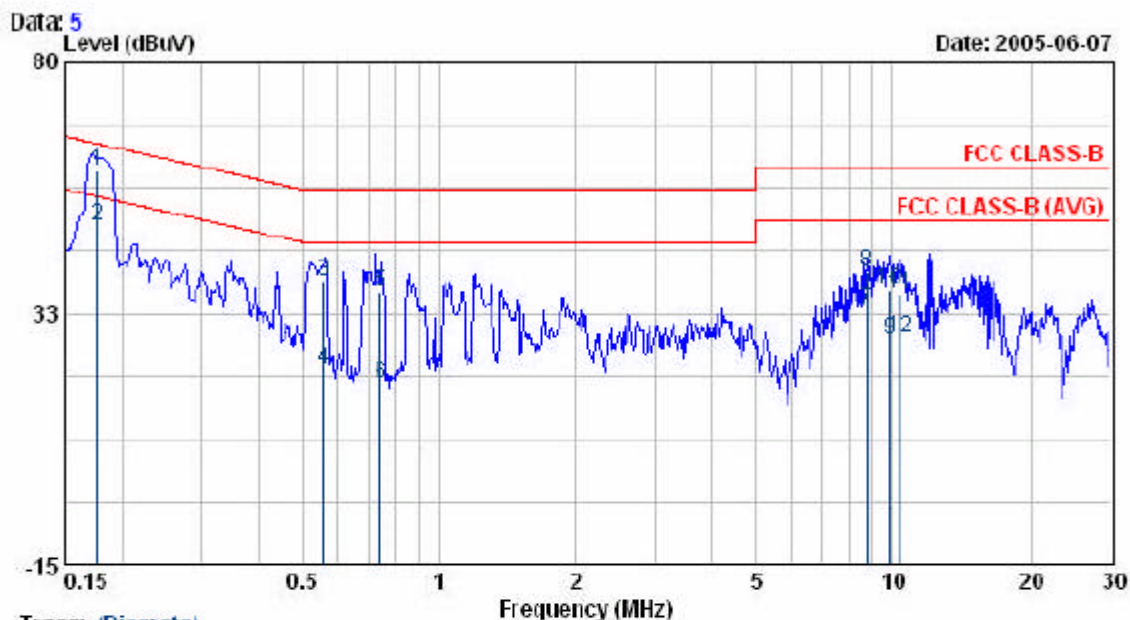

Trace: (Discrete)

Freq	Read Level	Factor	Level	Limit	Over Limit	Remark
MHz	dBuV	dB	dBuV	dBuV	dBuV	
0.18	59.28	0.14	59.42	64.66	-5.24	QP
0.18	48.82	0.14	48.96	54.66	-5.70	AVERAGE
0.56	38.09	0.36	38.45	56.00	-17.55	QP
0.56	21.66	0.36	22.02	46.00	-23.98	AVERAGE
0.74	36.18	0.33	36.51	56.00	-19.49	QP
0.74	18.83	0.33	19.16	46.00	-26.84	AVERAGE
8.79	32.56	0.31	32.87	50.00	-17.13	AVERAGE
8.79	39.86	0.31	40.17	60.00	-19.83	QP
9.88	27.13	0.30	27.43	50.00	-22.57	AVERAGE
9.88	36.39	0.30	36.69	60.00	-23.31	QP
10.42	35.77	0.33	36.10	60.00	-23.90	QP
10.42	27.38	0.33	27.71	50.00	-22.29	AVERAGE

Remarks: 1. Level = Read Level + Factor
 2. Factor = LISN(ISN) Factor + Cable Loss

EUT : Kwik Blue4-1
 Power : AC120V
 Test Mode : CH 39
 Memo :

Pol/Phase : LINE
 Temperature : 26 °C
 Humidity : 58 %

Data: 6

Level (dBuV)

Date: 2005-06-07

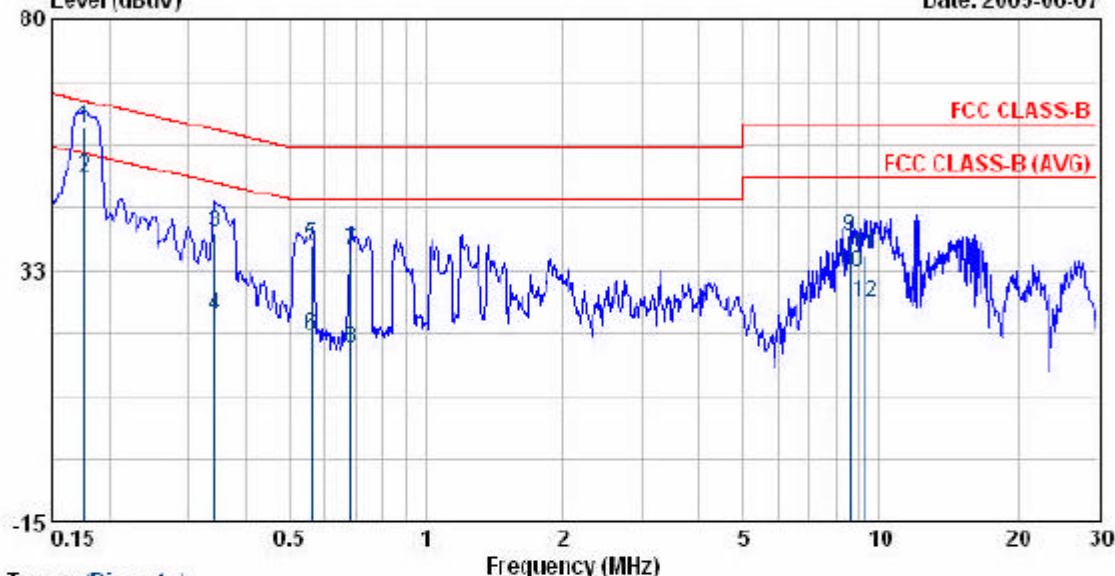

Trace: (Discrete)

Freq	Read	Factor	Level	Limit	Over	Remark
MHz	dBuV	dB	dBuV	dBuV	dBuV	
0.18	59.26	0.34	59.60	64.67	-5.08	QP
0.18	49.61	0.34	49.95	54.67	-4.73	AVERAGE
0.34	39.25	0.53	39.78	59.16	-19.38	QP
0.34	23.40	0.53	23.93	49.16	-25.23	AVERAGE
0.56	36.62	0.56	37.18	56.00	-18.82	QP
0.56	19.52	0.56	20.08	46.00	-25.92	AVERAGE
0.68	35.47	0.54	36.01	56.00	-19.99	QP
0.68	17.27	0.54	17.81	46.00	-28.19	AVERAGE
8.65	38.24	0.62	38.86	60.00	-21.14	QP
8.65	31.24	0.62	31.86	50.00	-18.14	AVERAGE
9.36	34.74	0.61	35.35	60.00	-24.65	QP
9.36	25.63	0.61	26.24	50.00	-23.76	AVERAGE

Remarks: 1. Level = Read Level + Factor
 2. Factor = LISN(ISN) Factor + Cable Loss

EVT : Kwik Blue4-1
 Power : AC120V
 Test Mode : CH 78
 Memo :

Pol/Phase : NEUTRAL
 Temperature : 26 °C
 Humidity : 5% %

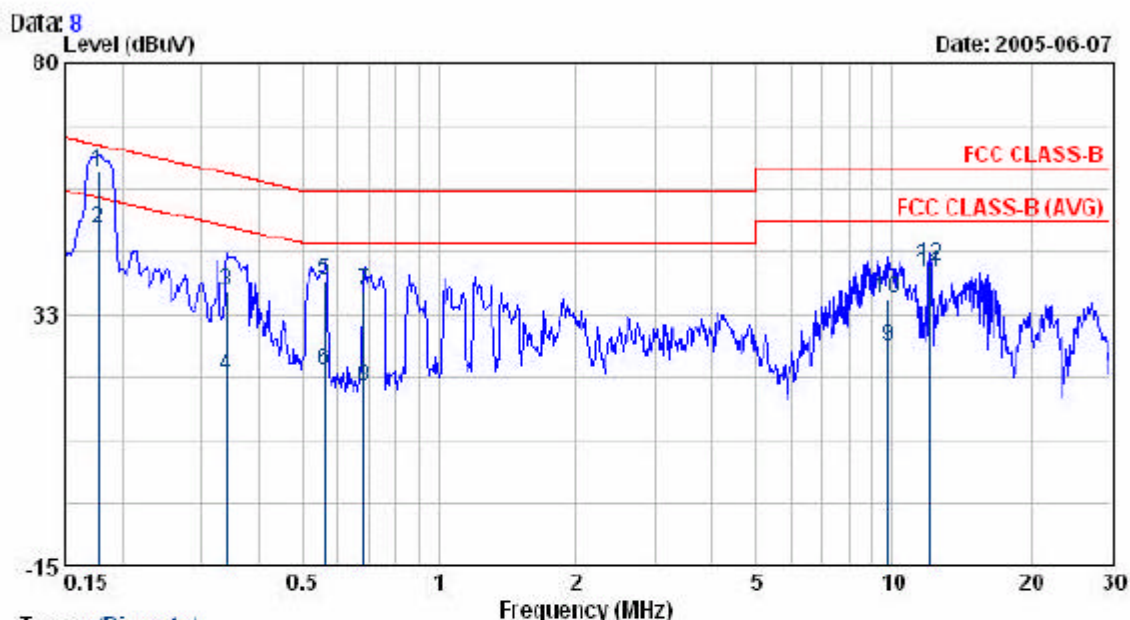

Trace: (Discrete)

Freq	Read Level	Factor	Level	Limit	Over Limit	Remark
MHz	dBuV	dB	dBuV	dBuV	dBuV	
0.18	59.37	0.13	59.50	64.62	-5.11	QP
0.18	48.57	0.13	48.70	54.62	-5.91	AVERAGE
0.34	36.59	0.33	36.92	59.18	-22.26	QP
0.34	20.34	0.33	20.67	49.18	-28.51	AVERAGE
0.56	38.54	0.36	38.90	56.00	-17.10	QP
0.56	21.52	0.36	21.88	46.00	-24.12	AVERAGE
0.68	36.43	0.34	36.77	56.00	-19.23	QP
0.68	18.53	0.34	18.87	46.00	-27.13	AVERAGE
9.80	26.04	0.30	26.34	50.00	-23.66	AVERAGE
9.80	35.07	0.30	35.37	60.00	-24.63	QP
12.00	39.80	0.43	40.23	50.00	-9.77	AVERAGE
12.00	41.35	0.43	41.78	60.00	-18.22	QP

Remarks: 1. Level = Read Level + Factor
 2. Factor = LISN(ISN) Factor + Cable Loss

EVT : Kwik Blue4-1
 Power : AC120V
 Test Mode : CH 78
 Memo :

Pol/Phase : LINE
 Temperature : 26 °C
 Humidity : 5% %

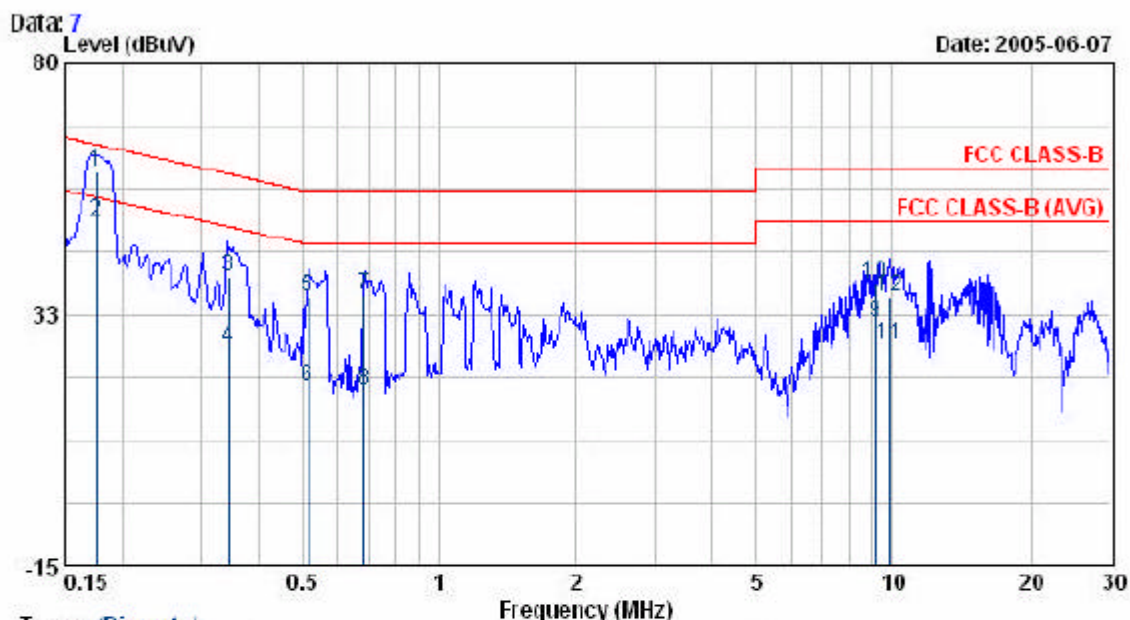

Trace: (Discrete)

Freq	Read Level	Factor	Level	Limit	Over Limit	Remark
MHz	dBuV	dB	dBuV	dBuV	dBuV	
0.18	59.23	0.34	59.57	64.68	-5.11	QP
0.18	49.76	0.34	50.10	54.68	-4.58	AVERAGE
0.34	39.01	0.53	39.54	59.10	-19.56	QP
0.34	25.53	0.53	26.06	49.10	-23.04	AVERAGE
0.51	35.23	0.57	35.80	56.00	-20.20	QP
0.51	18.03	0.57	18.60	46.00	-27.40	AVERAGE
0.68	35.60	0.54	36.14	56.00	-19.86	QP
0.68	17.35	0.54	17.89	46.00	-28.11	AVERAGE
9.18	30.30	0.61	30.91	50.00	-19.09	AVERAGE
9.18	37.68	0.61	38.29	60.00	-21.71	QP
9.89	26.30	0.60	26.90	50.00	-23.10	AVERAGE
9.89	35.23	0.60	35.83	60.00	-24.17	QP

Remarks: 1. Level = Read Level + Factor
 2. Factor = LISN(ISN) Factor + Cable Loss

Test engineer: Gallan

4.5.1 Test Photographs

FRONT VIEW



REAR VIEW



5. Test of Radiated Emission

5.1 Test Limit

Radiated emissions from 30 MHz to 25 GHz were measured according to the methods defines in ANSI C63.4-2003. The EUT was placed, 0.8 meter above the ground plane, as shown in section 5.6.3. The interface cables and equipment positions were varied within limits of reasonable applications to determine the positions producing maximum radiated emissions For unintentional device, according to § 15.109(a), except for Class A digital devices, the field strength of radiated emissions from unintentional radiators at a distance of 3 meters shall not exceed the following values:

Frequency (MHz)	Distance Meters	Radiated (μ V / M)	Radiated (dB μ V / M)
30-88	3	100	40.0
88-216	3	150	43.5
216-960	3	200	46.0
Above 960	3	500	54.0

For unintentional device, according to CISPR PUB.22, for Class B digital devices, the general requirement of field strength of radiated emissions from intentional radiators at a distance of 10 meters shall not exceed the above table.

Frequency (MHz)	Distance Meters	Radiated (dB μ V / M)
30-230	10	30
230-1000	10	37

5.2 Test Procedures

1. The EUT was placed on a rotatable table top 0.8 meter above ground.
2. The EUT was set 3 meters from the interference receiving antenna which was mounted on the top of a variable height antenna tower.
3. The table was rotated 360 degrees to determine the position of the highest radiation.
4. The antenna is a broadband antenna and its height is varied between one meter and four meters above ground to find the maximum value of the field strength both horizontal polarization and vertical polarization of the antenna are set to make the measurement.
5. For each suspected emission the EUT was arranged to its worst case and then tune the antenna tower (from 1 M to 4 M) and turn table (from 0 degree to 360 degrees) to find the maximum reading.
6. Set the test-receiver system to Peak or CISPR quasi-peak Detect Function and specified bandwidth with Maximum Hold Mode.
7. If the emission level of the EUT in peak mode was 3 dB lower than the limit specified, then testing will be stopped and peak values of EUT will be reported, otherwise, the emissions which do not have 3 dB margin will be repeated one by one using the quasi-peak method and reported.
8. For testing above 1GHz, the emission level of the EUT in peak mode was 20dB lower than average limit (that means the emission level in peak mode also complies with the limit in average mode), then testing will be stopped and peak values of EUT will be reported, otherwise, the emissions will be measured in average mode again and reported.

5.3 Typical Test Setup

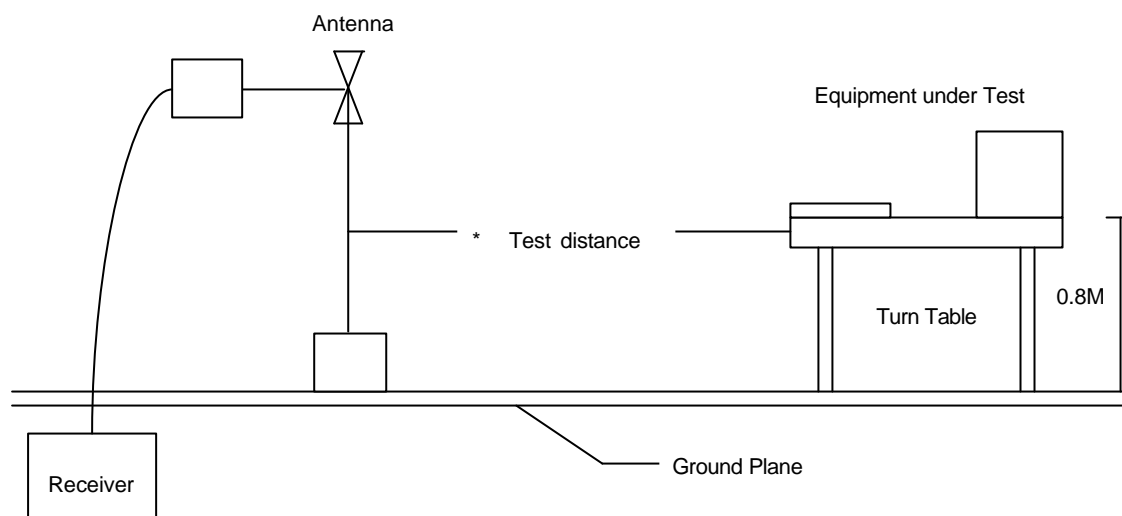

5.4 Measurement equipment

Instrument/Ancillary	Type	Manufacturer	Valid Date
EMI Receiver	8546A	HP	2006/04/13
Spectrum Analyzer	FSP40	R&S	2005/12/28
Horn Antenna	3115	EMCO	2006/02/21
Horn Antenna	3116	EMCO	2006/02/21
Bilog Antenna	CBL6112B	Schaffner	2006/04/12
Amplifier	8447D	Agilent	2005/06/30
Amplifier	8449B	Agilent	2005/12/27

5.5 Test Result and Data

EUT : Kwik Blue4-1
 Power : 120V
 Test Mode : Transmit/Receive
 Operation Channel: 0
 Modulation Type : GFSK
 Rate : 1 Mbps
 Pol/Phase : HORIZONTAL
 Temperature : 25 °C
 Humidity : 68 %
 Atmospheric Pressure: 1020 mmHg
 Memo :

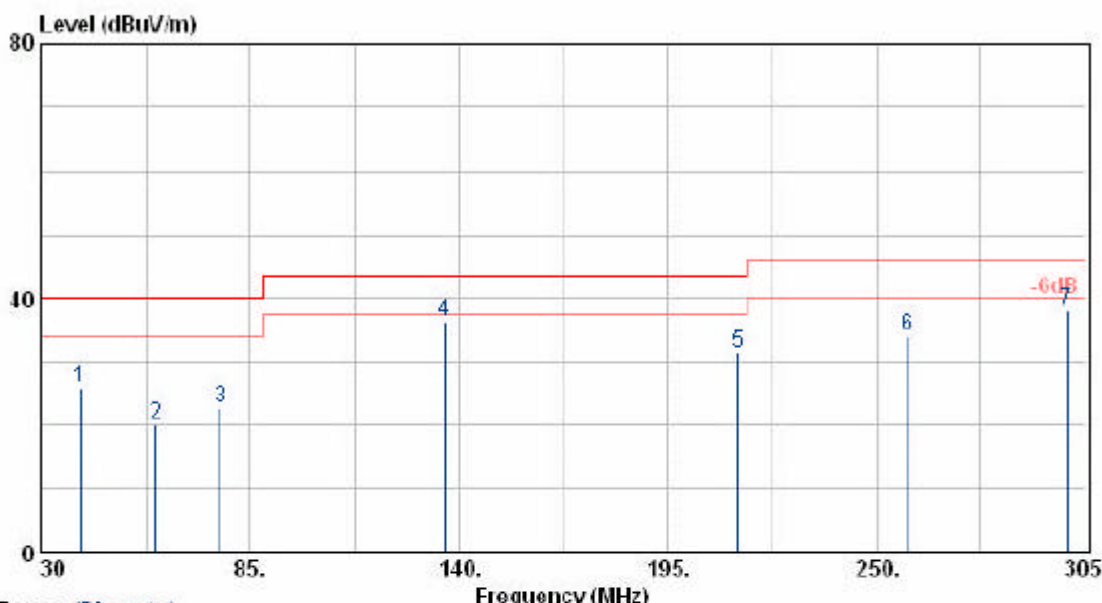

Trace: (Discrete)

Frequency (MHz)	Meter Reading (dBuV)	Corrected Factor (dBuV/m)	Result (dBuV/m)	Limit (dB)	Margin (dB)	Remark	Table Deg.	Ant High (cm)
39.98	34.88	-9.10	25.78	40.00	-14.22	Peak	95	100
60.12	41.81	-21.64	20.17	40.00	-19.83	Peak	95	100
77.21	40.95	-18.32	22.63	40.00	-17.37	Peak	320	100
136.10	51.06	-14.73	36.33	43.50	-7.17	Peak	300	100
213.40	48.87	-17.40	31.47	43.50	-12.03	Peak	300	100
258.30	46.50	-12.52	33.98	46.00	-12.02	Peak	240	100
299.99	49.13	-11.10	38.03	46.00	-7.97	Peak	240	100

Notes:

1. Result = Meter Reading + Corrected Factor
2. Corrected Factor = Antenna Factor + Cable Loss - Amplifier
3. The resolution bandwidth of test receiver/spectrum analyzer is 120KHz and video bandwidth is 300kHz for Peak detection and Quasi-peak detection at frequency below 1GHz.
4. The resolution bandwidth of test receiver/spectrum analyzer is 1MHz and video bandwidth is 3MHz for Peak detection at frequency above 1GHz.
5. The resolution bandwidth of test receiver/spectrum analyzer is 1MHz and video bandwidth is 10Hz for Average detection at frequency above 1GHz.
6. The other emissions is too below to be measured.

EUT	: Kwik Blue4-1	Pol/Phase	: HORIZONTAL
Power	: 120V	Temperature	: 25 °C
Test Mode	: Transmit/Receive	Humidity	: 68 %
Operation Channel	: 0	Atmospheric Pressure	: 1020 mmHg
Modulation Type	: GFSK	Memo	:
Rate	: 1 Mbps		

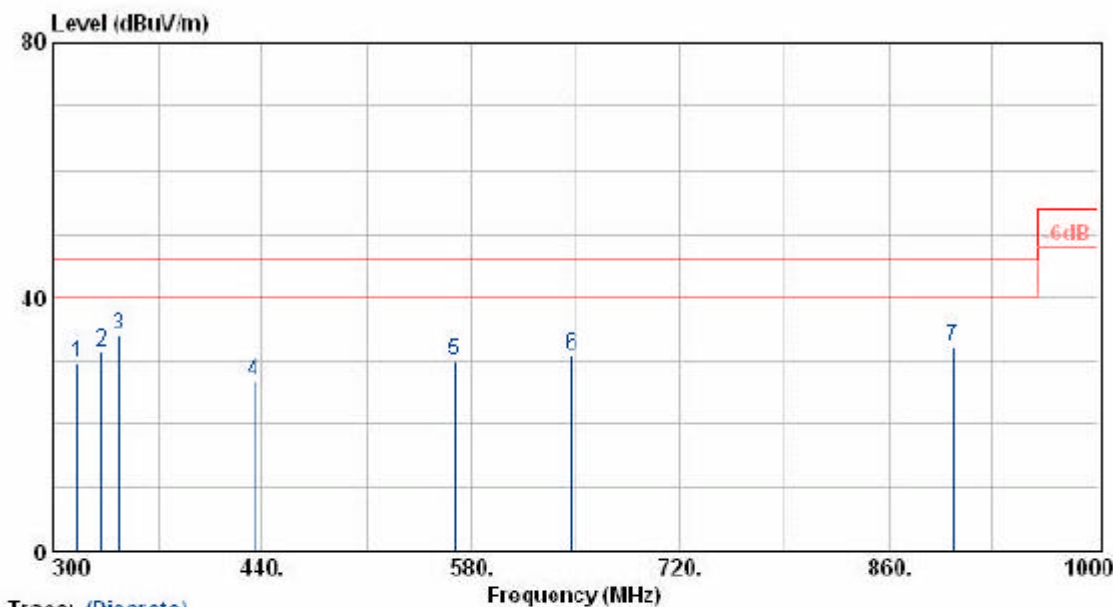

Trace: (Discrete)

Frequency (MHz)	Meter Reading (dBuV)	Corrected Factor (dBuV/m)	Result (dBuV/m)	Limit (dB)	Margin (dB)	Remark	Table Deg.	Ant High (cm)
316.52	40.55	-10.78	29.77	46.00	-16.23	Peak	80	100
332.12	42.08	-10.54	31.54	46.00	-14.46	Peak	80	100
344.35	44.38	-10.27	34.11	46.00	-11.89	Peak	30	100
433.98	35.35	-8.47	26.88	46.00	-19.12	Peak	200	100
558.72	34.89	-4.85	30.04	46.00	-15.96	Peak	140	100
647.23	34.71	-3.76	30.95	46.00	-15.05	Peak	80	100
903.10	31.18	1.23	32.41	46.00	-13.59	Peak	80	100

Notes:

1. Result = Meter Reading + Corrected Factor
2. Corrected Factor = Antenna Factor + Cable Loss - Amplifier
3. The resolution bandwidth of test receiver/spectrum analyzer is 120kHz and video bandwidth is 300kHz for Peak detection and Quasi-peak detection at frequency below 1GHz.
4. The resolution bandwidth of test receiver/spectrum analyzer is 1MHz and video bandwidth is 3MHz for Peak detection at frequency above 1GHz.
5. The resolution bandwidth of test receiver/spectrum analyzer is 1MHz and video bandwidth is 10Hz for Average detection at frequency above 1GHz.
6. The other emissions is too below to be measured.

EUT	: Kwik Blue4-1	Pol/Phase	: VERTICAL
Power	: 120V	Temperature	: 25 °C
Test Mode	: Transmit/Receive	Humidity	: 68 %
Operation Channel	: 0	Atmospheric Pressure	: 1020 mmHg
Modulation Type	: GFSK	Memo	:
Rate	: 1 Mbps		

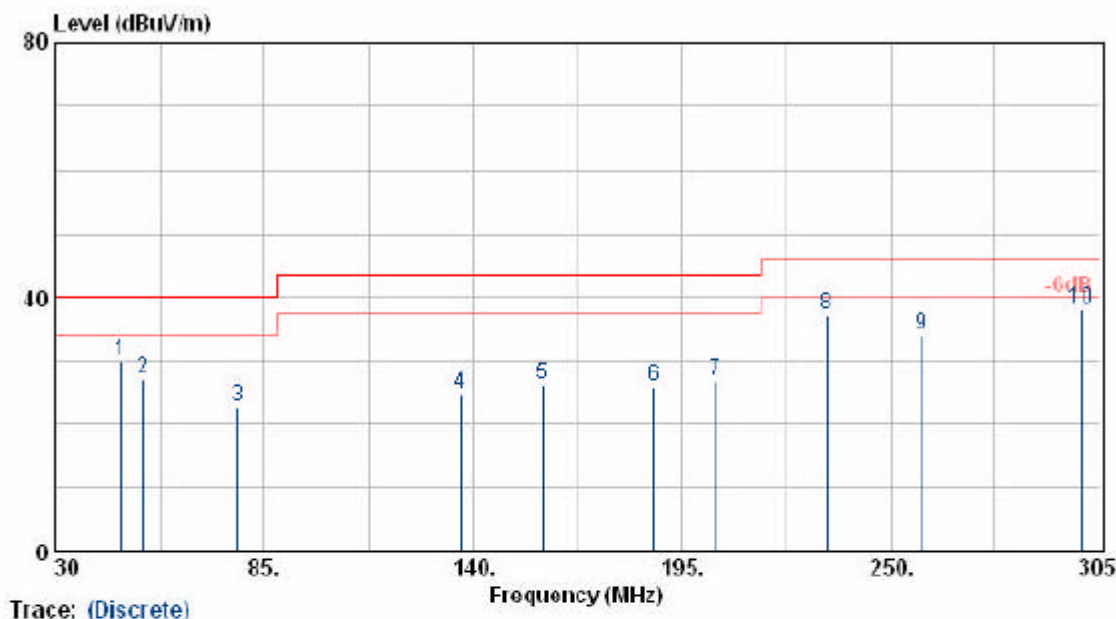

Frequency (MHz)	Meter Reading (dBuV)	Corrected Factor (dBuV/m)	Result (dBuV/m)	Limit (dB)	Margin (dB)	Remark	Table Deg.	Ant High (cm)
47.23	43.29	-13.45	29.84	40.00	-10.16	Peak	65	100
53.21	44.01	-16.97	27.04	40.00	-12.96	Peak	90	100
78.13	40.89	-18.12	22.77	40.00	-17.23	Peak	90	100
136.53	39.33	-14.70	24.63	43.50	-18.87	Peak	150	100
158.34	41.66	-15.48	26.18	43.50	-17.32	Peak	150	100
187.79	42.98	-17.07	25.91	43.50	-17.59	Peak	80	100
204.10	44.17	-17.29	26.88	43.50	-16.62	Peak	40	100
233.10	53.04	-15.79	37.25	46.00	-8.75	Peak	200	100
258.43	46.68	-12.51	34.17	46.00	-11.83	Peak	200	100
300.01	49.21	-11.10	38.11	46.00	-7.89	Peak	180	100

Notes:

1. Result = Meter Reading + Corrected Factor
2. Corrected Factor = Antenna Factor + Cable Loss - Amplifier
3. The resolution bandwidth of test receiver/spectrum analyzer is 120KHz and video bandwidth is 300kHz for Peak detection and Quasi-peak detection at frequency below 1GHz.
4. The resolution bandwidth of test receiver/spectrum analyzer is 1MHz and video bandwidth is 3MHz for Peak detection at frequency above 1GHz.
5. The resolution bandwidth of test receiver/spectrum analyzer is 1MHz and video bandwidth is 10Hz for Average detection at frequency above 1GHz.
6. The other emissions is too below to be measured.

EUT	: Kwik Blue4-1	Pol/Phase	: VERTICAL
Power	: 120V	Temperature	: 25 °C
Test Mode	: Transmit/Receive	Humidity	: 68 %
Operation Channel	: 0	Atmospheric Pressure	: 1020 mmHg
Modulation Type	: GFSK	Memo	:
Rate	: 1 Mbps		

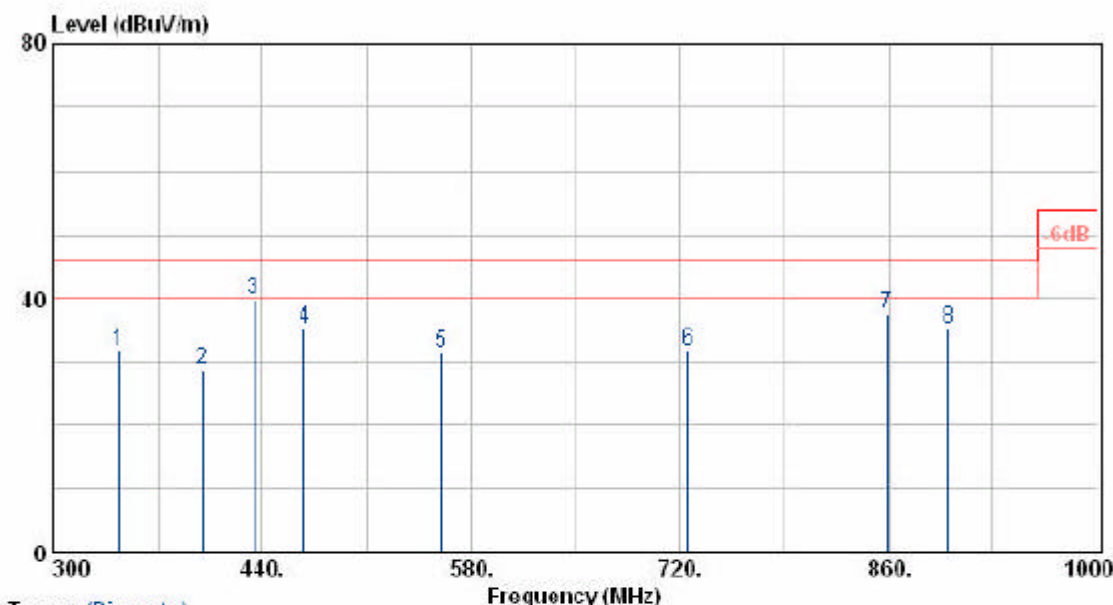

Frequency (MHz)	Meter Reading (dBuV)	Corrected Factor (dBuV/m)	Result (dBuV/m)	Limit (dB)	Margin (dB)	Remark	Table Deg.	Ant High (cm)
344.24	41.87	-10.27	31.60	46.00	-14.40	Peak	100	100
399.98	37.31	-8.59	28.72	46.00	-17.28	Peak	100	100
434.13	48.42	-8.47	39.95	46.00	-6.05	Peak	200	100
458.38	43.03	-7.92	35.11	46.00	-10.89	Peak	250	100
559.90	36.52	-5.05	31.47	46.00	-14.53	Peak	250	100
724.98	33.65	-1.99	31.66	46.00	-14.34	Peak	145	100
859.16	37.05	0.50	37.55	46.00	-8.45	Peak	145	100
900.00	33.96	1.24	35.20	46.00	-10.80	Peak	50	100

Notes:

1. Result = Meter Reading + Corrected Factor
2. Corrected Factor = Antenna Factor + Cable Loss - Amplifier
3. The resolution bandwidth of test receiver/spectrum analyzer is 120kHz and video bandwidth is 300kHz for Peak detection and Quasi-peak detection at frequency below 1GHz.
4. The resolution bandwidth of test receiver/spectrum analyzer is 1MHz and video bandwidth is 3MHz for Peak detection at frequency above 1GHz.
5. The resolution bandwidth of test receiver/spectrum analyzer is 1MHz and video bandwidth is 10Hz for Average detection at frequency above 1GHz.
6. The other emissions is too below to be measured.

EVT	: Kwik Blue4-1	Pol/Phase	: HORIZONTAL
Power	: 120V	Temperature	: 28 °C
Test Mode	: Transmit/Receive	Humidity	: 67 %
Operation Channel	: 0	Atmospheric Pressure	: 1019 mmHg
Modulation Type	: GFSK	Memo	:
Rate	: 1 Mbps		

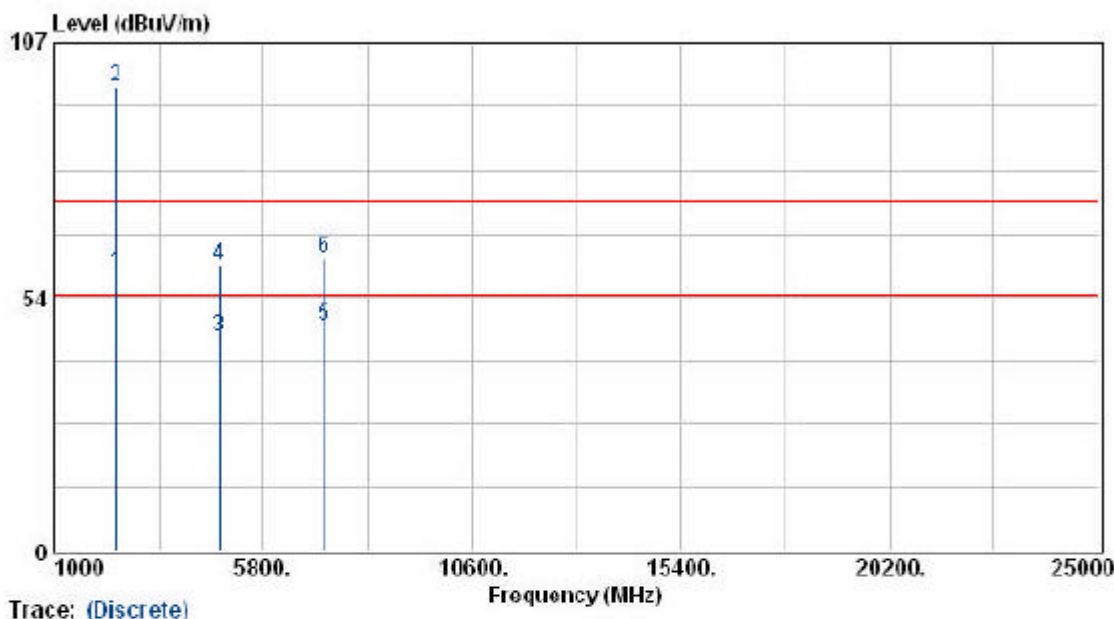

Frequency (MHz)	Meter Reading (dBUV)	Corrected Factor (dBUV/m)	Result (dBUV/m)	Limit (dB)	Margin (dB)	Remark	Table Deg.	Ant High (cm)
2402.00	57.30	1.29	58.59	54.00	4.59	Average	99	100
2402.00	96.42	1.29	97.71	74.00	23.71	Peak	99	100
4804.00	36.90	8.05	44.95	54.00	-9.05	Average	232	100
4804.00	52.18	8.05	60.23	74.00	-13.77	Peak	232	100
7206.00	35.49	11.83	47.32	54.00	-6.68	Average	186	100
7206.00	49.86	11.83	61.69	74.00	-12.31	Peak	186	100

Notes:

1. Result = Meter Reading + Corrected Factor
2. Corrected Factor = Antenna Factor + Cable Loss - Amplifier
3. The resolution bandwidth of test receiver/spectrum analyzer is 120KHz and video bandwidth is 300kHz for Peak detection and Quasi-peak detection at frequency below 1GHz.
4. The resolution bandwidth of test receiver/spectrum analyzer is 1MHz and video bandwidth is 3MHz for Peak detection at frequency above 1GHz.
5. The resolution bandwidth of test receiver/spectrum analyzer is 1MHz and video bandwidth is 10Hz for Average detection at frequency above 1GHz.
6. The other emissions is too below to be measured.
7. 2402,2441,2480 MHz is fundamental frequency.

EUT	: Kwik Blue4-1	Pol/Phase	: VERTICAL
Power	: 120V	Temperature	: 28 °C
Test Mode	: Transmit/Receive	Humidity	: 67 %
Operation Channel	: 0	Atmospheric Pressure	: 1019 mmHg
Modulation Type	: GFSK	Memo	:
Rate	: 1 Mbps		

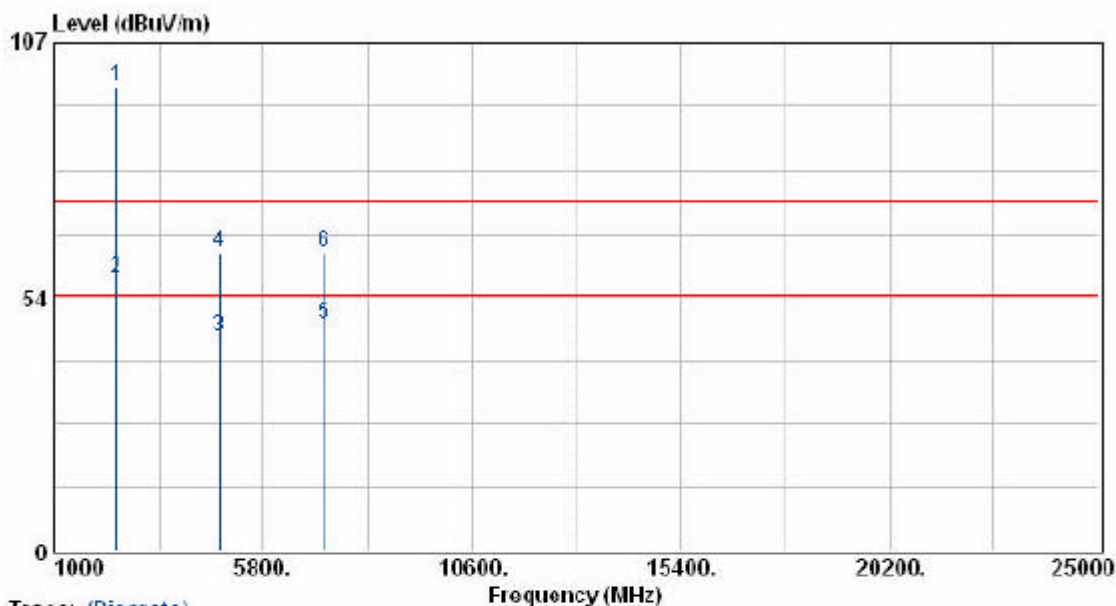

Trace: (Discrete)

Frequency (MHz)	Meter Reading (dBuV)	Corrected Factor (dBuV/m)	Result (dBuV/m)	Limit (dB)	Margin (dB)	Remark	Table Deg.	Ant High (cm)
2402.20	97.09	0.59	97.68	74.00	23.68	Peak	57	100
2402.20	57.13	0.59	57.72	54.00	3.72	Average	57	100
4804.10	37.89	7.29	45.18	54.00	-8.82	Average	52	100
4804.10	55.67	7.29	62.96	74.00	-11.04	Peak	52	100
7206.00	36.67	11.02	47.69	54.00	-6.31	Average	214	100
7206.00	52.00	11.02	63.02	74.00	-10.98	Peak	214	100

Notes:

1. Result = Meter Reading + Corrected Factor
2. Corrected Factor = Antenna Factor + Cable Loss - Amplifier
3. The resolution bandwidth of test receiver/spectrum analyzer is 120KHz and video bandwidth is 300kHz for Peak detection and Quasi-peak detection at frequency below 1GHz.
4. The resolution bandwidth of test receiver/spectrum analyzer is 1MHz and video bandwidth is 3MHz for Peak detection at frequency above 1GHz.
5. The resolution bandwidth of test receiver/spectrum analyzer is 1MHz and video bandwidth is 10Hz for Average detection at frequency above 1GHz.
6. The other emissions is too below to be measured.
7. 2402,2441,2480 MHz is fundamental frequency.