

## TEST REPORT

**Report No.: 19020372HKG-003**

MGA Entertainment (HK) Ltd.

Application For Certification  
(Original Grant)

**FCC ID: LU9649523RX**

Transceiver

**Prepared and Checked by:**

**Approved by:**

Signed On File  
Lee For Yiu, Florey  
Assistant Engineer

---

Wong Kwok Yeung, Kenneth  
Senior Lead Engineer  
Date: April 08, 2019

---

Intertek's standard Terms and Conditions can be obtained at our website <http://www.intertek.com/terms/>.

The test report only allows to be revised within the retention period unless further standard or the requirement was noticed.

This report is for the exclusive use of Intertek's Client and is provided pursuant to the agreement between Intertek and its Client. Intertek's responsibility and liability are limited to the terms and conditions of the agreement. Intertek assumes no liability to any party, other than to the Client in accordance with the agreement, for any loss, expense or damage occasioned by the use of this report. Only the Client is authorized to permit copying or distribution of this report and then only in its entirety. Any use of the Intertek name or one of its marks for the sale or advertisement of the tested material, product or service must first be approved in writing by Intertek. The observations and test results in this report are relevant only to the sample tested. This report by itself does not imply that the material, product, or service is or has ever been under an Intertek certification program.

© 2017 Intertek

## TEST REPORT

### GENERAL INFORMATION

<b>Grantee:</b>	MGA Entertainment (HK) Ltd.
<b>Grantee Address:</b>	6th Floor, YHC Tower, 1 Sheung Yuet Road, Kowloon Bay, Kowloon, Hong Kong.
<b>Contact Person:</b>	Roy Au
<b>Tel:</b>	(852) 27329200
<b>Fax:</b>	(852) 27329242
<b>e-mail:</b>	RAU@mgae.com
<b>Manufacturer:</b>	MGA Entertainment (HK) Ltd.
<b>Manufacturer Address:</b>	6th Floor, YHC Tower, 1 Sheung Yuet Road, Kowloon Bay, Kowloon, Hong Kong.
<b>Brand Name:</b>	YouDrive Rescue Chopper
<b>Model:</b>	649523
<b>Additional Model:</b>	649523E4C
<b>Asst. No:</b>	649523
<b>Type of EUT:</b>	Transceiver
<b>Description of EUT:</b>	YouDrive Rescue Chopper
<b>Serial Number:</b>	N/A
<b>FCC ID:</b>	LU9649523RX
<b>Date of Sample Submitted:</b>	February 19, 2019
<b>Date of Test:</b>	February 19, 2019 to April 03, 2019
<b>Report No.:</b>	19020372HKG-003
<b>Report Date:</b>	April 08, 2019
<b>Environmental Conditions:</b>	Temperature: +10 to 40°C Humidity: 10 to 90%
<b>Conclusion:</b>	Test was conducted by client submitted sample. The submitted sample as received complied with the 47 CFR Part 15.

## TEST REPORT

### SUMMARY OF TEST RESULT

Test Specification	Reference	Results
Radiated Emission Radiated Emission on the Bandedge	15.249, 15.209	Pass
Radiated Emission in Restricted Bands	15.205	Pass

The equipment under test is found to be complying with the following standards:  
FCC Part 15, October 1, 2017 Edition

- Note:
1. The EUT uses a permanently attached antenna which, in accordance to section 15.203, is considered sufficient to comply with the provisions of this section.
  2. Pursuant to FCC part 15 Section 15.215(c), the 20 dB bandwidth of the emission was contained within the frequency band designated (mentioned as above) which the EUT operated. The effects, if any, from frequency sweeping, frequency hopping, other modulation techniques and frequency stability over excepted variations in temperature and supply voltage were considered.

## TEST REPORT

### TABLE OF CONTENTS

<b>1.0</b>	<b>GENERAL DESCRIPTION .....</b>	<b>5</b>
1.1	Product Description .....	5
1.2	Related Submittal(s) Grants.....	5
1.3	Test Methodology .....	5
1.4	Test Facility .....	5
<b>2.0</b>	<b>SYSTEM TEST CONFIGURATION .....</b>	<b>6</b>
2.1	Justification .....	6
2.2	EUT Exercising Software .....	6
2.3	Special Accessories.....	6
2.4	Measurement Uncertainty .....	6
2.5	Support Equipment List and Description .....	6
<b>3.0</b>	<b>EMISSION RESULTS.....</b>	<b>7</b>
3.1	Field Strength Calculation.....	7
3.2	Radiated Emission Configuration Photograph.....	8
3.3	Radiated Emission Data .....	8
<b>4.0</b>	<b>EQUIPMENT PHOTOGRAPHS .....</b>	<b>12</b>
<b>5.0</b>	<b>PRODUCT LABELLING.....</b>	<b>12</b>
<b>6.0</b>	<b>TECHNICAL SPECIFICATIONS .....</b>	<b>12</b>
<b>7.0</b>	<b>INSTRUCTION MANUAL.....</b>	<b>12</b>
<b>8.0</b>	<b>MISCELLANEOUS INFORMATION .....</b>	<b>13</b>
8.1	Radiated Emission on the Bandedge.....	13
8.2	Emissions Test Procedures .....	13
<b>9.0</b>	<b>CONFIDENTIALITY REQUEST .....</b>	<b>16</b>
<b>10.0</b>	<b>EQUIPMENT LIST .....</b>	<b>16</b>

## TEST REPORT

### 1.0 GENERAL DESCRIPTION

#### 1.1 Product Description

The Equipment Under Test (EUT), is a portable 2.4GHz Transceiver (Plane Unit) for a RC Plane. The sample supplied operated on 55 channels, normally at 2418 - 2472 MHz for transmitter and receiver. The channels are separated by 1MHz channel spacing.

The EUT is powered by 3.7V rechargeable battery. After switch on the EUT, the plane will be moved forward or backward and turned left and right based on the switches pressed in the controller.

The Model: 649523E4C is the same as the Model: 649523 in hardware aspect as declared by client. The difference in model number serves as marketing strategy as declared by client. The models are different in packaging only as declared by client.

Antenna Type: Internal, Integral

For electronic filing, the brief circuit description is saved with filename: descri.pdf.

#### 1.2 Related Submittal(s) Grants

This is a single application for certification of a transceiver.

The Certification procedure of transceiver for this transceiver (with FCC ID: LU9649523TX) is being processed as the same time of this application.

#### 1.3 Test Methodology

Radiated emission measurements were performed according to the procedures in ANSI C63.10 (2013). All radiated measurements were performed in an 3m Chamber. Preliminary scans were performed in the 3m Chamber only to determine worst case modes. All radiated tests were performed at an antenna to EUT distance of 3 meters, unless stated otherwise in the “**Justification Section**” of this Application.

#### 1.4 Test Facility

The 3m Chamber facility used to collect the radiated data is located at Workshop No. 3, G/F., World-Wide Industrial Centre, 43-47 Shan Mei Street, Fo Tan, Sha Tin, N.T., Hong Kong. This test facility and site measurement data have been placed on file with the FCC.

## TEST REPORT

### 2.0 SYSTEM TEST CONFIGURATION

#### 2.1 Justification

The system was configured for testing in a typical fashion (as a customer would normally use it), and in the confines as outlined in ANSI C63.10 (2013).

The device was powered by DC 3.7 V (1 x 3.7 V Rechargeable battery).

For maximizing emissions, the EUT was rotated through 360°, the antenna height was varied from 1 meter to 4 meters above the ground plane, and the antenna polarization was changed. This step by step procedure for maximizing emissions led to the data reported in Exhibit 3.0.

The unit was operated standalone and placed in the center of the turntable.

The equipment under test (EUT) was configured for testing in a typical fashion (as a customer would normally use it). The EUT was mounted to a plastic stand if necessary and placed on the wooden turntable, which enabled the engineer to maximize emissions through its placement in the three orthogonal axes.

#### 2.2 EUT Exercising Software

There was no special software to exercise the device. Once the unit is powered up, it transmits the RF signal continuously.

#### 2.3 Special Accessories

There are no special accessories necessary for compliance of this product.

#### 2.4 Measurement Uncertainty

When determining of the test conclusion, the Measurement Uncertainty of test has been considered.

Uncertainty and Compliance - Unless the standard specifically states that measured values are to be extended by the measurement uncertainty in determining compliance, all compliance determinations are based on the actual measured value.

#### 2.5 Support Equipment List and Description

N/A.

## TEST REPORT

### 3.0 EMISSION RESULTS

Data is included of the worst case configuration (the configuration which resulted in the highest emission levels). A sample calculation, configuration photographs and data tables of the emissions are included.

#### 3.1 Field Strength Calculation

The field strength is calculated by adding the Antenna Factor and Cable Factor, and subtracting the Amplifier Gain (if any), Average Factor (optional) from the measured reading. The basic equation with a sample calculation is as follows:

$$FS = RA + AF + CF - AG - AV$$

where FS = Field Strength in dB $\mu$ V/m

RA = Receiver Amplitude (including preamplifier) in dB $\mu$ V

CF = Cable Attenuation Factor in dB

AF = Antenna Factor in dB

AG = Amplifier Gain in dB

AV = Average Factor in dB

In the following table(s), the reading shown on the data table reflects the preamplifier gain. An example for the calculations in the following table is as follows:

$$FS = RR + LF$$

where FS = Field Strength in dB $\mu$ V/m

RR = RA - AG - AV in dB $\mu$ V

LF = CF + AF in dB

Assume a receiver reading of 52.0 dB $\mu$ V is obtained. The antenna factor of 7.4 dB and cable factor of 1.6 dB are added. The amplifier gain of 29 dB and average factor of 5 dB are subtracted, giving a field strength of 27 dB $\mu$ V/m. This value in dB $\mu$ V/m was converted to its corresponding level in  $\mu$ V/m.

$$RA = 52.0 \text{ dB}\mu\text{V/m}$$

$$AF = 7.4 \text{ dB}$$

$$CF = 1.6 \text{ dB}$$

$$AG = 29.0 \text{ dB}$$

$$AV = 5.0 \text{ dB}$$

$$FS = RR + LF$$

$$FS = 18 + 9 = 27 \text{ dB}\mu\text{V/m}$$

$$RR = 18.0 \text{ dB}\mu\text{V}$$

$$LF = 9.0 \text{ dB}$$

$$\text{Level in } \mu\text{V/m} = \text{Common Antilogarithm } [(27 \text{ dB}\mu\text{V/m})/20] = 22.4 \mu\text{V/m}$$

## TEST REPORT

### 3.2 Radiated Emission Configuration Photograph

The worst case in radiated emission was found at 2483.5 and 14832 MHz

For electronic filing, the worst case radiated emission configuration photographs are saved with filename: radiated photos.pdf.

### 3.3 Radiated Emission Data

The data on the following page lists the significant emission frequencies, the limit and the margin of compliance. Numbers with a minus sign are below the limit.

Judgment: Passed by 15.5 dB



## TEST REPORT

### RADIATED EMISSIONS

Model: 649523

Date of Test: April 03, 2019

Worst-Case Operating Mode: Transmitting

Table 1  
Pursuant to FCC Part 15 Section 15.249 Requirement

#### Lowest Channel

Polarization	Frequency (MHz)	Reading (dB $\mu$ V)	Pre-Amp Gain (dB)	Antenna Factor (dB)	Net at 3m - Average (dB $\mu$ V/m)	Average Limit at 3m (dB $\mu$ V/m)	Margin (dB)
V	2418.000	71.8	33	29.4	68.2	94.0	-25.8
V	2400.000	39.9	33	29.4	36.3	54.0	-17.7
<b>H</b>	<b>4836.000</b>	<b>32.5</b>	<b>33</b>	<b>34.9</b>	<b>34.4</b>	<b>54.0</b>	<b>-19.6</b>
<b>H</b>	<b>7254.000</b>	<b>27.4</b>	<b>33</b>	<b>37.9</b>	<b>32.3</b>	<b>54.0</b>	<b>-21.7</b>
H	9672.000	27.3	33	40.4	34.7	54.0	-19.3
<b>H</b>	<b>12090.000</b>	<b>29.4</b>	<b>33</b>	<b>40.5</b>	<b>36.9</b>	<b>54.0</b>	<b>-17.1</b>
H	14508.000	32.9	33	38.4	38.3	54.0	-15.7

Polarization	Frequency (MHz)	Reading (dB $\mu$ V)	Pre-Amp Gain (dB)	Antenna Factor (dB)	Net at 3m - Peak (dB $\mu$ V/m)	Peak Limit at 3m (dB $\mu$ V/m)	Margin (dB)
V	2418.000	91.9	33	29.4	88.3	114.0	-25.7
V	2400.000	56.5	33	29.4	52.9	74.0	-21.1
<b>H</b>	<b>4836.000</b>	<b>53.1</b>	<b>33</b>	<b>34.9</b>	<b>55.0</b>	<b>74.0</b>	<b>-19.0</b>
<b>H</b>	<b>7254.000</b>	<b>41.5</b>	<b>33</b>	<b>37.9</b>	<b>46.4</b>	<b>74.0</b>	<b>-27.6</b>
H	9672.000	40.9	33	40.4	48.3	74.0	-25.7
<b>H</b>	<b>12090.000</b>	<b>42.8</b>	<b>33</b>	<b>40.5</b>	<b>50.3</b>	<b>74.0</b>	<b>-23.7</b>
H	14508.000	46.0	33	38.4	51.4	74.0	-22.6

- NOTES:
1. Peak Detector Data unless otherwise stated.
  2. Average detector is applied according to ANSI C63.10.
  3. All measurements were made at 3 meters. Harmonic emissions not detected at the 3-meter distances were measured at 0.3-meter and an inverse proportional extrapolation was performed to compare the signal level to the 3-meter limit. No other harmonic emissions than those reported were detected at a test distance of 0.3-meter.
  4. Negative sign in the column shows value below limit.
  5. Horn antenna is used for the emission over 1000MHz.
  6. Emission (the row indicated by **bold italic**) within the restricted band meets the requirement of FCC Part 15 Section 15.205.
  7. Measurement Uncertainty is  $\pm 5.3$ dB at a level of confidence of 95%.

**TEST REPORT**

Model: 649523

Date of Test: April 03, 2019

Worst-Case Operating Mode: Transmitting

**Table 2**  
**Pursuant to FCC Part 15 Section 15.249 Requirement**

Middle Channel

Polarization	Frequency (MHz)	Reading (dBμV)	Pre-Amp Gain (dB)	Antenna Factor (dB)	Net at 3m - Average (dBμV/m)	Average Limit at 3m (dBμV/m)	Margin (dB)
V	2445.000	73.2	33	29.4	69.6	94.0	-24.4
<b><i>H</i></b>	<b><i>4890.000</i></b>	<b><i>32.6</i></b>	<b><i>33</i></b>	<b><i>34.9</i></b>	<b><i>34.5</i></b>	<b><i>54.0</i></b>	<b><i>-19.5</i></b>
<b><i>H</i></b>	<b><i>7335.000</i></b>	<b><i>27.3</i></b>	<b><i>33</i></b>	<b><i>37.9</i></b>	<b><i>32.2</i></b>	<b><i>54.0</i></b>	<b><i>-21.8</i></b>
H	9780.000	27.4	33	40.4	34.8	54.0	-19.2
<b><i>H</i></b>	<b><i>12225.000</i></b>	<b><i>29.8</i></b>	<b><i>33</i></b>	<b><i>40.5</i></b>	<b><i>37.3</i></b>	<b><i>54.0</i></b>	<b><i>-16.7</i></b>
H	14670.000	32.8	33	38.4	38.2	54.0	-15.8

Polarization	Frequency (MHz)	Reading (dBμV)	Pre-Amp Gain (dB)	Antenna Factor (dB)	Net at 3m - Peak (dBμV/m)	Peak Limit at 3m (dBμV/m)	Margin (dB)
V	2445.000	93.1	33	29.4	89.5	114.0	-24.5
<b><i>H</i></b>	<b><i>4890.000</i></b>	<b><i>53.3</i></b>	<b><i>33</i></b>	<b><i>34.9</i></b>	<b><i>55.2</i></b>	<b><i>74.0</i></b>	<b><i>-18.8</i></b>
<b><i>H</i></b>	<b><i>7335.000</i></b>	<b><i>41.4</i></b>	<b><i>33</i></b>	<b><i>37.9</i></b>	<b><i>46.3</i></b>	<b><i>74.0</i></b>	<b><i>-27.7</i></b>
H	9780.000	41.0	33	40.4	48.4	74.0	-25.6
<b><i>H</i></b>	<b><i>12225.000</i></b>	<b><i>43.1</i></b>	<b><i>33</i></b>	<b><i>40.5</i></b>	<b><i>50.6</i></b>	<b><i>74.0</i></b>	<b><i>-23.4</i></b>
H	14670.000	45.8	33	38.4	51.2	74.0	-22.8

- NOTES:
1. Peak Detector Data unless otherwise stated.
  2. Average detector is applied according to ANSI C63.10.
  3. All measurements were made at 3 meters. Harmonic emissions not detected at the 3-meter distances were measured at 0.3-meter and an inverse proportional extrapolation was performed to compare the signal level to the 3-meter limit. No other harmonic emissions than those reported were detected at a test distance of 0.3-meter.
  4. Negative sign in the column shows value below limit.
  5. Horn antenna is used for the emission over 1000MHz.
  6. Emission (the row indicated by bold italic) within the restricted band meets the requirement of FCC Part 15 Section 15.205.
  7. Measurement Uncertainty is ±5.3dB at a level of confidence of 95%.

## TEST REPORT

Model: 649523

Date of Test: April 03, 2019

Worst-Case Operating Mode: Transmitting

Table 3  
Pursuant to FCC Part 15 Section 15.249 Requirement

### Highest Channel

Polarization	Frequency (MHz)	Reading (dB $\mu$ V)	Pre-Amp Gain (dB)	Antenna Factor (dB)	Net at 3m - Average (dB $\mu$ V/m)	Average Limit at 3m (dB $\mu$ V/m)	Margin (dB)
V	2472.000	74.1	33	29.4	70.5	94.0	-23.5
<b><i>V</i></b>	<b><i>2483.500</i></b>	<b><i>42.1</i></b>	<b><i>33</i></b>	<b><i>29.4</i></b>	<b><i>38.5</i></b>	<b><i>54.0</i></b>	<b><i>-15.5</i></b>
<b><i>H</i></b>	<b><i>4944.000</i></b>	<b><i>32.1</i></b>	<b><i>33</i></b>	<b><i>34.9</i></b>	<b><i>34.0</i></b>	<b><i>54.0</i></b>	<b><i>-20.0</i></b>
<b><i>H</i></b>	<b><i>7416.000</i></b>	<b><i>27.8</i></b>	<b><i>33</i></b>	<b><i>37.9</i></b>	<b><i>32.7</i></b>	<b><i>54.0</i></b>	<b><i>-21.3</i></b>
H	9888.000	27.9	33	40.4	35.3	54.0	-18.7
<b><i>H</i></b>	<b><i>12360.000</i></b>	<b><i>29.7</i></b>	<b><i>33</i></b>	<b><i>40.5</i></b>	<b><i>37.2</i></b>	<b><i>54.0</i></b>	<b><i>-16.8</i></b>
H	14832.000	33.1	33	38.4	38.5	54.0	-15.5

Polarization	Frequency (MHz)	Reading (dB $\mu$ V)	Pre-Amp Gain (dB)	Antenna Factor (dB)	Net at 3m - Peak (dB $\mu$ V/m)	Peak Limit at 3m (dB $\mu$ V/m)	Margin (dB)
V	2472.000	93.8	33	29.4	90.2	114.0	-23.8
<b><i>V</i></b>	<b><i>2483.500</i></b>	<b><i>58.9</i></b>	<b><i>33</i></b>	<b><i>29.4</i></b>	<b><i>55.3</i></b>	<b><i>74.0</i></b>	<b><i>-18.7</i></b>
<b><i>H</i></b>	<b><i>4944.000</i></b>	<b><i>52.9</i></b>	<b><i>33</i></b>	<b><i>34.9</i></b>	<b><i>54.8</i></b>	<b><i>74.0</i></b>	<b><i>-19.2</i></b>
<b><i>H</i></b>	<b><i>7416.000</i></b>	<b><i>41.9</i></b>	<b><i>33</i></b>	<b><i>37.9</i></b>	<b><i>46.8</i></b>	<b><i>74.0</i></b>	<b><i>-27.2</i></b>
H	9888.000	41.3	33	40.4	48.7	74.0	-25.3
<b><i>H</i></b>	<b><i>12360.000</i></b>	<b><i>42.8</i></b>	<b><i>33</i></b>	<b><i>40.5</i></b>	<b><i>50.3</i></b>	<b><i>74.0</i></b>	<b><i>-23.7</i></b>
H	14832.000	46.0	33	38.4	51.4	74.0	-22.6

- NOTES:
1. Peak Detector Data unless otherwise stated.
  2. Average detector is applied according to ANSI C63.10.
  3. All measurements were made at 3 meters. Harmonic emissions not detected at the 3-meter distances were measured at 0.3-meter and an inverse proportional extrapolation was performed to compare the signal level to the 3-meter limit. No other harmonic emissions than those reported were detected at a test distance of 0.3-meter.
  4. Negative sign in the column shows value below limit.
  5. Horn antenna is used for the emission over 1000MHz.
  6. Emission (the row indicated by bold italic) within the restricted band meets the requirement of FCC Part 15 Section 15.205.
  7. Measurement Uncertainty is  $\pm 5.3$ dB at a level of confidence of 95%.

## TEST REPORT

### 4.0 EQUIPMENT PHOTOGRAPHS

For electronic filing, the photographs are saved with filename: external photos.pdf and internal photos.pdf.

### 5.0 PRODUCT LABELLING

For electronics filing, the FCC ID label artwork and the label location are saved with filename: label.pdf.

### 6.0 TECHNICAL SPECIFICATIONS

For electronic filing, the block diagram and schematic of the tested EUT are saved with filename: block.pdf and circuit.pdf respectively.

### 7.0 INSTRUCTION MANUAL

For electronic filing, a preliminary copy of the Instruction Manual is saved with filename: manual.pdf.

This manual will be provided to the end-user with each unit sold/leased in the United States.

## TEST REPORT

### 8.0 MISCELLANEOUS INFORMATION

The miscellaneous information includes details of the test procedure and measured bandwidth.

#### 8.1 Radiated Emission on the Bandedge

The test data of bandedge emissions were shown on the above radiated emissions table 1 & table 3 respectively.

Emissions radiated outside of the specified frequency bands, except harmonics, are attenuated by 50dB below the level of the fundamental or to the general radiated emissions limits in Section 15.209, whichever is the lesser attenuation, which meet the requirement of part 15.249(d).

#### 8.2 Emissions Test Procedures

The following is a description of the test procedure used by Intertek Testing Services Hong Kong Ltd. in the measurements of transmitter operating under the Part 15, Subpart C rules.

The transmitting equipment under test (EUT) is placed on a wooden turntable which is four feet in diameter and approximately 0.8m in height above the ground plane for emission measurement at or below 1GHz and 1.5m in height above the ground plane for emission measurement above 1GHz. During the radiated emissions test, the turntable is rotated and any cables leaving the EUT are manipulated to find the configuration resulting in maximum emissions. The EUT is adjusted through all three orthogonal axis to obtain maximum emission levels. The antenna height and polarization are also varied during the testing to search for maximum signal levels. The height of the antenna is varied from one to four meters.

Detector function for radiated emissions is in peak mode. Average readings, when required, are taken by measuring the duty cycle of the equipment under test and subtracting the corresponding amount in dB from the measured peak readings. A detailed description for the calculation of the average factor can be found in Exhibit 8.3.

The frequency range scanned is from the lowest radio frequency signal generated in the device which is greater than 9 kHz to the tenth harmonic of the highest fundamental frequency or 40 GHz, whichever is lower.

## TEST REPORT

### 8.2 Emissions Test Procedures (cont'd)

The EUT is warmed up for 15 minutes prior to the test.

AC power to the unit is varied from 85% to 115% nominal and variation in the fundamental emission field strength is recorded. If battery powered, a new, fully charged battery is used.

Conducted measurements were made as described in ANSI C63.10 (2013).

The IF bandwidth used for measurement of radiated signal strength was 100 kHz or greater when frequency is below 1000 MHz. Where pulsed transmissions of short enough pulse duration warrant, a greater bandwidth is selected according to the recommendations of Hewlett Packard Application Note 150-2. A discussion of whether pulse desensitivity is applicable to this unit is included in this report (See Exhibit 8.1). Above 1000 MHz, a resolution bandwidth of 10 MHz is used.

Transmitter measurements are normally conducted at a measurement distance of three meters. However, to assure low enough noise floor in the forbidden bands and above 1 GHz, signals are acquired at a distance of one meter or less. All measurements are extrapolated to three meters using inverse scaling, unless otherwise reported. Measurements taken at a closer distance are so marked.

## TEST REPORT

### 8.2.1 Radiated Emission Test Setup

The figure below shows the test setup, which is utilized to make these measurements.

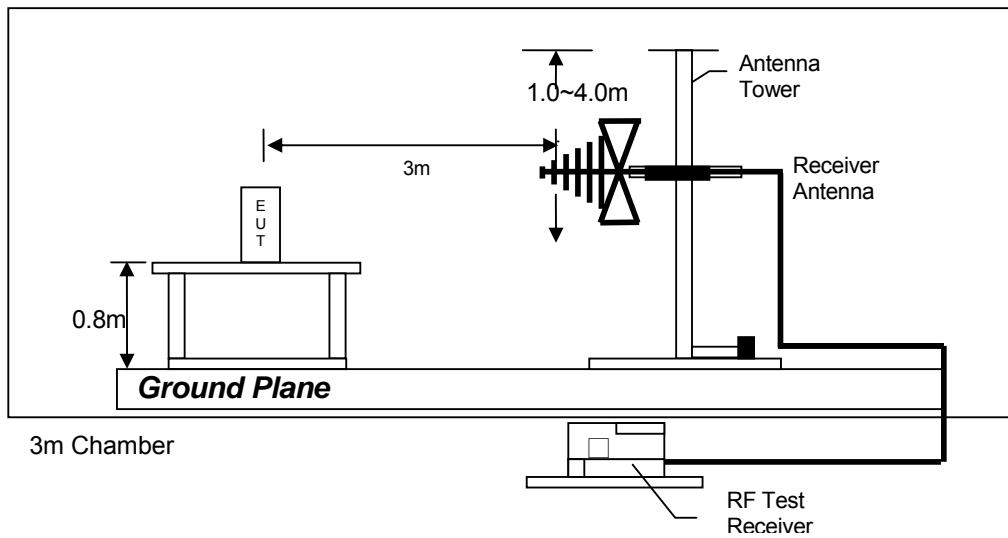

Test setup of radiated emissions up to 1GHz

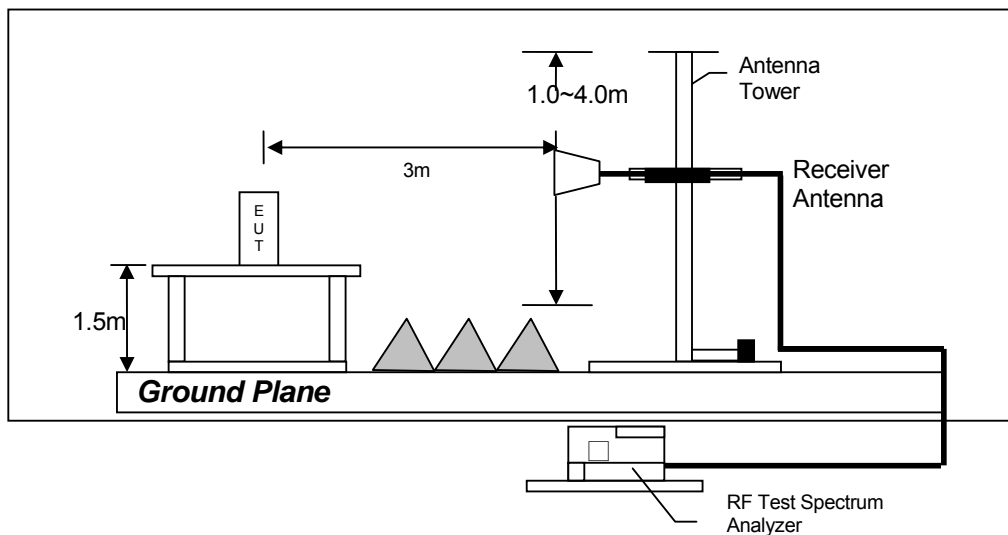

Test setup of radiated emissions above 1GHz

## TEST REPORT

### 9.0 CONFIDENTIALITY REQUEST

For electronic filing, a preliminary copy of the confidentiality request is saved with filename: request.pdf.

### 10.0 EQUIPMENT LIST

#### 1) Radiated Emissions Test

Equipment	EMI Test Receiver	Spectrum Analyzer	Biconical Antenna
Registration No.	EW-2666	EW-2425	EW-0571
Manufacturer	ROHDESCHWARZ	ROHDESCHWARZ	EMCO
Model No.	ESCI7	FSP3	3104C
Calibration Date	August 28, 2018	August 17, 2018	February 27, 2018
Calibration Due Date	August 28, 2019	August 17, 2019	August 27, 2019

Equipment	Log Periodic Antenna	Double Ridged Guide Antenna	14m Double Shield RF Cable (20MHz - 6GHz)
Registration No.	EW-0447	EW-1015	EW-2074
Manufacturer	EMCO	EMCO	RADIALL
Model No.	3148	3115	Nm-RG142-
Calibration Date	January 17, 2018	November 17, 2017	April 27, 2018
Calibration Due Date	July 17, 2019	May 17, 2019	April 27, 2019

Equipment	RF Cable 14m (1GHz to 26.5GHz)	RF Pre-amplifier 3 pcs (9kHz to 40GHz)	Horn Antenna (14GHz - 40GHz)
Registration No.	EW-2781	EW-3006	EW-1679
Manufacturer	GREATBILLION	SCHWARZBECK	SCHWARZBECK
Model No.	SMA m/SHF5MPU /SMA m ra14m,26G	BBV 9718	BBHA9170
Calibration Date	October 27, 2018	April 26, 2018	September 25, 2018
Calibration Due Date	October 27, 2019	April 26, 2019	September 25, 2019

#### 2) Bandwidth Measurement

Equipment	Spectrum Analyzer
Registration No.	EW-2249
Manufacturer	R&S
Model No.	FSP30
Calibration Date	May 17, 2018
Calibration Due Date	May 17, 2019

**END OF TEST REPORT**