



# Test report

according to ISO/IEC 17025:2017

**FCC**

**(Federal Communications Commission)**

**Test Firm Registration Number: 768032**

**Designation Number DE0022**

**ISED**

**(Innovation, Science and Economic Development)**

**CAB identifier: DE0012**

**ISED#: 6155A**

## Electromagnetic compatibility

Intentional Radiators



Deutsche  
Akkreditierungsstelle  
D-PL-17379-01-00  
D-PL-17379-01-02  
D-PL-17379-01-03



Bundesnetzagentur

BNetzA-CAB-18/21-19

 **TESTED  
IN GERMANY**

**STC Germany GmbH**  
Ohmstrasse 1  
84160 Frontenhausen, Germany  
Tel.: + 49 (0) 8732 6381  
Fax: + 49 (0) 8732 2345  
E-mail: grstc@stc.group

Test report no.: **20/03-0044-A**

Page 1 of 29 pages

## Table of contents

1.	Client information .....	3
2.	Equipment under test (EUT) .....	3
3.	Description of the Equipment under test and test conditions .....	4
4.	Performed measurements and results .....	5
5.	AC Mains conducted emissions .....	6
6.	Radiated emission measurements .....	7
7.	Output Power of Fundamental Emission .....	16
8.	99% Power Bandwidth .....	17
9.	20 dB Bandwidth .....	18
10.	Periodic Operation .....	20
11.	Test equipment .....	22
12.	Test Setups .....	24
13.	Measurement uncertainty .....	26
14.	Photos setup .....	27
15.	Conclusions .....	28
16.	Photos of tested sample .....	29

### Location of test facility:



**STC Germany GmbH**  
**Ohmstrasse 1**  
**84160 Frontenhausen**  
**Germany**

## 1. Client information

Name: APTIV Services Deutschland GmbH  
Address: Am Technologiepark 1  
42119 Wuppertal, Germany  
Name of contact: Ljiljana Trivic  
Telephone: +49 2261 971415  
Fax: +49 2261 72691  
E-mail: Ljiljana.trivic@aptiv.com

## 2. Equipment under test (EUT)

### 2.1 Identification of the EUT

Equipment: 433 MHz Transmitter and 125KHz Receiver  
Model: FI7WE  
Brand name: APTIV  
Serial no.: -/-  
Manufacturer: APTIV Services Deutschland GmbH  
Wiehlpuhl 4  
51766 Engelkirchen  
-Germany-  
Country of origin: Germany  
Power rating: 3 V = (coin battery CR2032)  
Highest frequency generated or used  
in the device or on which the device  
operates or tunes (MHz): 434 MHz  
Date Sample Received: 25.03.2020  
Tests were performed: 14.04.2020 – 06.08.2020

### 2.2 Additional information about the EUT:

Battery operated equipment

**To duplicate parts of this test report needs the written confirmation of the test laboratory.**

**The test results relate only to the above mentioned test sample(s).**

### 3. Description of the Equipment under test and test conditions

FCC-ID:	LTQFI7WE
IC:	3659A-FI7WE
HVIN:	FI7WE
FVIN:	2.05
Cables:	-/-
Approx. Size (l x w x h):	(4.2 x 2.5 x 1.1) cm
Test conditions:	<p>The "433 MHz Transmitter and 125KHz Receiver - FI7WE" (=equipment under test – EUT) had been tested while transmitting with operating frequency at 433,920 MHz and receiving at 125 kHz.</p> <p>The transmitter function is used for the PEPS (Passiv Entry Passiv Start) System.</p> <p>The tested configuration represents (based on the product specification) with the tested operation modes the worst case.</p>
Additional information:	-/-
Operating frequencies:	Transmitter: 433,92 MHz      Receiver: 125 kHz
Type of modulation:	FSK
Spurious Emissions: (radiated lowest margin to limit)	AV 53,46 dB $\mu$ V/m (0,54 dB) @ 3 m
Environmental conditions during tests:	Ambient temperature:                      20 °C Relative humidity                              42 % Atmospheric pressure                          955 mbar
Antenna Transmitter:	Model: PCB Antenna  Type: <input type="checkbox"/> External <input checked="" type="checkbox"/> Internal (integrated, PCB antenna)

#### 4. Performed measurements and results

The complete list of measurements required in e-CFR Title 47 Chapter I Subchapter A Part 15 Subpart C & RSS-210 is given below.

Standard:	Standard:	Test Method:		Test requirements:			
				applicable:		fulfilled:	
				Yes	No	Yes	No
§ 15.207	RSS-210 issue 10 RSS-Gen issue 5	ANSI 63.10 Section 6.2	AC Mains Conducted Emissions	<input type="checkbox"/>	<input checked="" type="checkbox"/>	<input type="checkbox"/>	<input type="checkbox"/>
§ 15.209	RSS-210 issue 10 RSS-Gen issue 5	ANSI 63.10 Section 6.3 - 6.6	Radiated Emissions	<input checked="" type="checkbox"/>	<input type="checkbox"/>	<input checked="" type="checkbox"/>	<input type="checkbox"/>
§15.231	RSS-210 issue 10	ANSI 63.10 Section 6.4	Output Power of Fundamental Emissions	<input checked="" type="checkbox"/>	<input type="checkbox"/>	<input checked="" type="checkbox"/>	<input type="checkbox"/>
§15.231	RSS-210 issue 10	ANSI 63.10 Section 6.9.2	20 dB Bandwidth	<input checked="" type="checkbox"/>	<input type="checkbox"/>	<input checked="" type="checkbox"/>	<input type="checkbox"/>
§15.231	RSS-210 issue 10	ANSI 63.10 Section 7.4	Periodic Operation	<input checked="" type="checkbox"/>	<input type="checkbox"/>	<input checked="" type="checkbox"/>	<input type="checkbox"/>
-/-	RSS-210 issue 10 RSS-Gen issue 5	ANSI 63.10 Section 6.9.3	99% Power Bandwidth	<input checked="" type="checkbox"/>	<input type="checkbox"/>	<input checked="" type="checkbox"/>	<input type="checkbox"/>

All required / applicable tests according to the following standards were performed under Ref-No. 20/03-0044.

- e-CFR Title 47 Chapter I Subchapter A Part 15 Subpart C with test Method according to ANSI C63.10-2013
- e-CFR data is current as of April 17, 2020

- RSS-210 issue 10 December 2019 Licence-Exempt Radio Apparatus: Category I Equipment
- RSS-Gen issue 5 March 2019 General Requirements for Compliance of Radio Apparatus

**Remark: -/-**

## 5. AC Mains conducted emissions

### Applied standards

-e-CFR Title 47 Chapter I Subchapter A Part 15 Subpart C, § 15.207 Conducted limits  
-RSS-Gen issue 05 section 7.2

### Test site

Not applicable

### Test equipment and test set up

Not applicable

### Detector function selection and bandwidth

Not applicable

### Frequency range to be scanned

Not applicable

### Test conditions and configuration of EUT

Not applicable

### Requirements

Frequency Range [MHz]	Quasi-Peak Limits [dB $\mu$ V]	Average Limits [dB $\mu$ V]
0.15 - 0.5	66 to 56 <sup>Note 1</sup>	56 to 46 <sup>Note 1</sup>
0.5 - 5.0	56	46
5.0 - 30.0	60	50
Note 1: The level decreases linearly with the logarithm of the frequency		

### Measurement

The measurement is not applicable. The EUT is powered via battery.

## 6. Radiated emission measurements

### Test site

Measurement of radiated emissions from EUT was made in the semi-anechoic chamber SAC3 (DC to 40 GHz) located in the test facility.

### Test equipment and test set up

Test equipment used for radiated measurements as given in clause Test equipment of this report.  
Test setup used for radiated measurements as given in clause Test Setups of this report.

### Detector function selection and bandwidth

In radiated emissions measurement, an EMI test receiver with CISPR detectors was used.

Frequency range	Resolution Bandwidth
9KHz – 150kHz (Quasi Peak & Average* Detector)	200Hz
150KHz – 30MHz (Quasi Peak & Average* Detector)	9kHz
30MHz – 1GHz (Quasi Peak Detector)	120kHz
Above 1GHz (Peak & Average Detector)	1MHz

\*Average Detector only in specified frequency range.

### Antennas

Measurements were made using a calibrated loop antenna in the range 9 kHz – 30 MHz, as well as a calibrated bilog antenna in the range of 30 to 1000 MHz to determine the emission characteristics of the EUT. Measurements were also made for both horizontal and vertical polarization in a SAC .

The horizontal distance between the receiving antenna and the EUT was 3 meters.

In the range of 1 GHz to 26 GHz measurements were made using a calibrated horn antenna to determine the emission characteristics of the EUT. Measurements were also made for both horizontal and vertical polarization in a SAC with floor absorbers. The horizontal distance between the receiving antenna and the EUT was 3 meters.

### Frequency range to be scanned

For radiated emissions measurements, the spectrum in the range of 9kHz MHz to 7 GHz was investigated as the highest used frequency in the EUT is 433.92 MHz.

### Test conditions and configuration of EUT

The EUT was configured and operated with conditions as mentioned under “Test conditions” in clause 3.

During test the EUT was operated as specified in the technical instruction of the EUT. For frequencies below 1000 MHz the EUT was placed on a 80 cm and for frequencies above 1000 MHz the EUT was placed on a 150 cm high non metallic table placed on the turntable. The EUT was rotated and the antenna height was varied between 1 m to 4 m to find the maximum RF energy generated from EUT. The procedure according to ANSI C63.10:2013 is used and all modes are investigated by operating the EUT in a range of typical modes of operation, with typical cable positions, and with a typical system equipment configuration and arrangement. For each mode of operation, cable manipulation are performed within the range of likely configurations. The highest values measured are shown in the table below.

**Remarks:**

-Correction factor included antenna factor and cable attenuation.

**Applied standards**

 -e-CFR Title 47 Chapter I Subchapter A Part 15 Subpart C, § 15.209 Radiated emission limits  
 -RSS-Gen issue 05 section 8.9

**Requirements**
**acc. e-CFR Title 47 Chapter I Subchapter A Part 15 Subpart C, § 15.209 Radiated emission limits**

Frequency MHz	Limits [ $\mu\text{V}/\text{m}$ ] Quasi-peak	Limits [dB $\mu\text{V}/\text{m}$ ] Quasi-peak	Limits [ $\mu\text{V}/\text{m}$ ] Average	Limits [dB $\mu\text{V}/\text{m}$ ] Average	Test distance [m]
0.009 – 0.090	-/-	-/-	2400/F (kHz)	48.5 – 28.5	300
0.090 - 0.110	2400/F (kHz)	28.5 – 26.8	-/-	-/-	300
0.110 – 0.490	-/-	-/-	2400/F (kHz)	26.8 – 13.8	300
0.490 - 1.705	24000/F (kHz)	33.8 – 23.0	-/-	-/-	30
1.705 - 30.0	30	29.5	-/-	-/-	30

**acc. RSS-Gen issue 05 section 8.9**

Frequency MHz	Limits [ $\mu\text{A}/\text{m}$ ] Quasi-peak	Limits [dB $\mu\text{A}/\text{m}$ ] Quasi-peak	Limits [ $\mu\text{A}/\text{m}$ ] Average	Limits [dB $\mu\text{A}/\text{m}$ ] Average	Test distance [m]
0.009 – 0.090	-/-	-/-	6.37/F (kHz)	-3 – -23.0	300
0.090 - 0.110	6.37/F (kHz)	-23.0 – -24.7	-/-	-/-	300
0.110 – 0.490	-/-	-/-	6.37/F (kHz)	-24.7 – -37.7	300
0.490 - 1.705	63.7/F (kHz)	-17.7 – -28.5	-/-	-/-	30
1.705 - 30.0	0.08	-22	-/-	-/-	30

**acc. e-CFR Title 47 Chapter I Subchapter A Part 15 Subpart C, § 15.209 Radiated emission limits and RSS-Gen issue 05 section 8.9**

Frequency MHz	Limits [ $\mu\text{V}/\text{m}$ ] Quasi-peak	Limits [dB $\mu\text{V}/\text{m}$ ] Quasi-peak	Limits [ $\mu\text{V}/\text{m}$ ] Average	Limits [dB $\mu\text{V}/\text{m}$ ] Average	Test distance [m]
30 - 88	100	40	-/-	-/-	3
88 - 216	150	43.5	-/-	-/-	3
216 - 960	200	46	-/-	-/-	3
960 - 1000	500	54	-/-	-/-	3
Above 1000	-/-	-/-	500	54	3

**Measurements**

The Measurement was performed on: 14.04.2020

**Result 9 kHz – 30 MHz**

In the frequency range 9 kHz – 30 MHz the EUT had been scanned in a distance of 3 m and the Limit were corrected to the test distance of 3 m using a factor with 40 dB/decade acc. to § 15.31 (f)(2).

Only the worst case of the X,Y and Z axis measurement is documented in this report.





**IT 3/4**

Interference radiation (9kHz – 30MHz)  
acc.FCC § 15.209 / RSS-Gen



Ref.-No.: 20/03-0044

Product: Transmitting/Receiving System

Sample: 06

Date: 09.04.2020

Operator: BI

Remarks:

Result:  pass  fail

Operation mode: Transmitting 433,92MHz; Receiving 125kHz

**Position X (9kHz - 150kHz)**

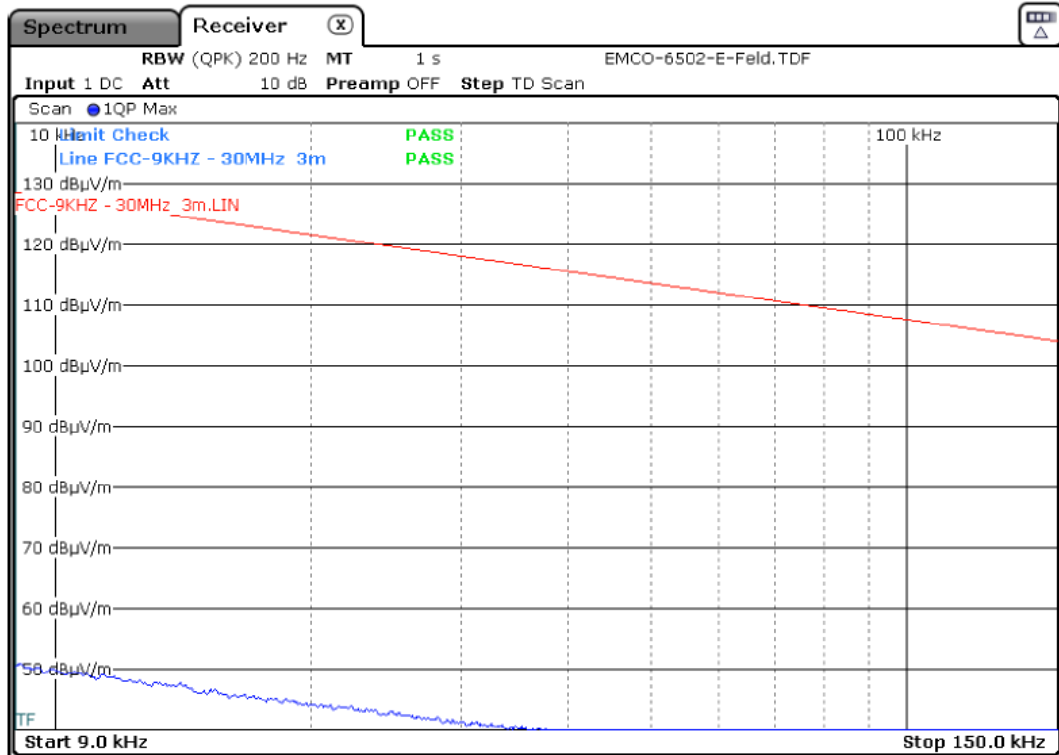

Position: X				
Detector QP				
Frequ. [MHz]	Level [dBµV/m]	Margin to Limit [dB]	Limit [dBµV/m]	Result
9kHz-150kHz	-/-	>20	-/-	pass



**IT 3/4**  
Interference radiation (9kHz – 30MHz)  
acc.FCC § 15.209 / RSS-Gen



Ref.-No.: 20/03-0044

Operation mode: Transmitting 433,92MHz; Receiving 125kHz

**Position X (150kHz – 30MHz)**

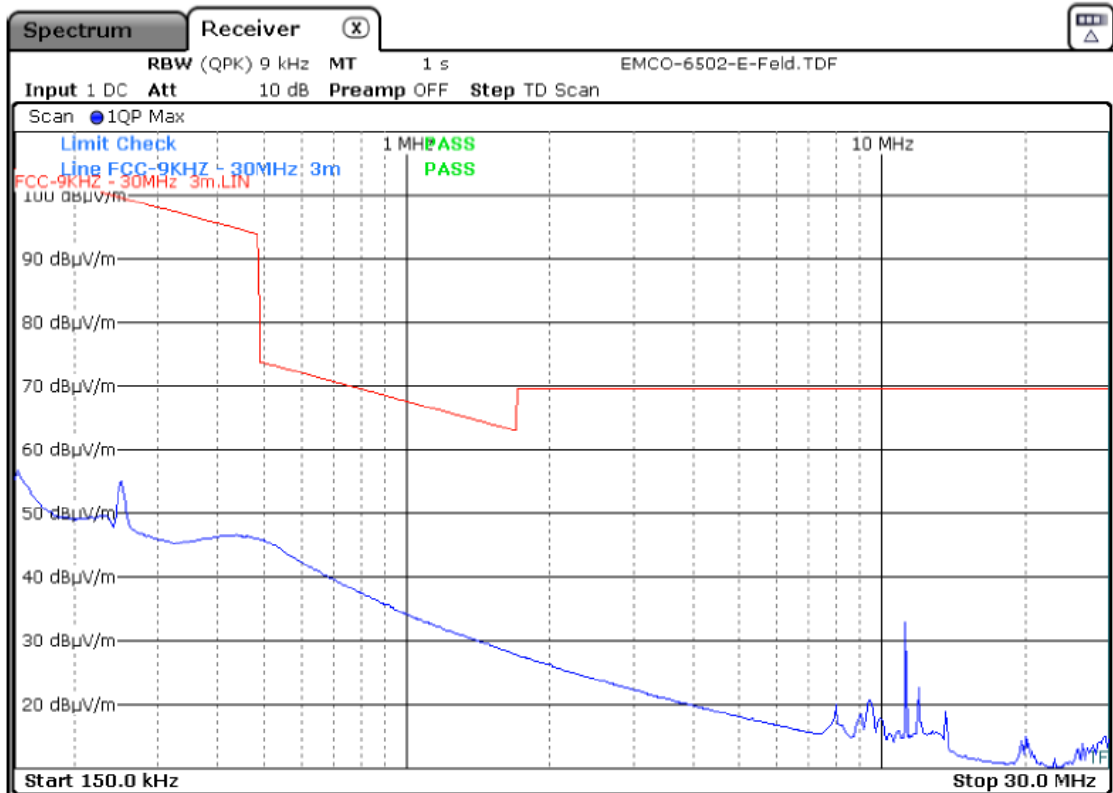

Position: X				
Detector QP				
Frequ. [MHz]	Level [dBµV/m]	Margin to Limit [dB]	Limit [dBµV/m]	Result
150kHz-30MHz	-/-	>20	-/-	pass

**Summary result for frequency range 9 kHz - 30 MHz to show compliance with RSS-Gen limits:**

Function	Freq.	Measured Value @ 3m [dBµV/m]	Conversion to magnetic field <sup>Note 1</sup>		Limit @ 3m		Margin [dB]	Result
	[MHz]		[dBµA/m]	[µA/m]	[dBµA/m]	[µA/m]		
Transmitting 433,92 MHz	0.009 – 0.490	< 73.8	< 22.3	-/-	77 - 42.3	-/-	>20	Pass
	0.490 – 1.705	< 43.0	< -8.5	-/-	22.3 - 11.5	-/-	>20	Pass
	1.705 - 30	< 49.5	< -2.0	-/-	18	-/-	>20	Pass

Note 1: Conversion E-field to H-Field:  
 $x \text{ [dBµV/m]} - 51.5 = y \text{ [dBµA/m]}$

Conversion [dBµA/m] in [µA/m]  
 $10^{(y \text{ [dBµA/m]} / 20)} = z \text{ [µA/m]}$

**Result 30 MHz – 1000 MHz**

Ref.-No.: 20/03-0044  
 Product: TRANS.-/REC.-SYSTEM  
 Sample: 06  
 Date: 14 Apr. 2020  
 Operator: BL

Test equipment:  
 Rohde & Schwarz ESV5  
 CHASE CBL 6111  
 Connected sets:

Operating mode:  
 TRANSMITTING 433.92MHz  
 RECEIVING 125KHz

test distance 3m  
 RFI suppression parts:

**IT 5/6**

STC Germany GmbH

Interference Radiation 30 MHz – 1000 MHz  
 acc. FCC 15.209 / RSS-Gen

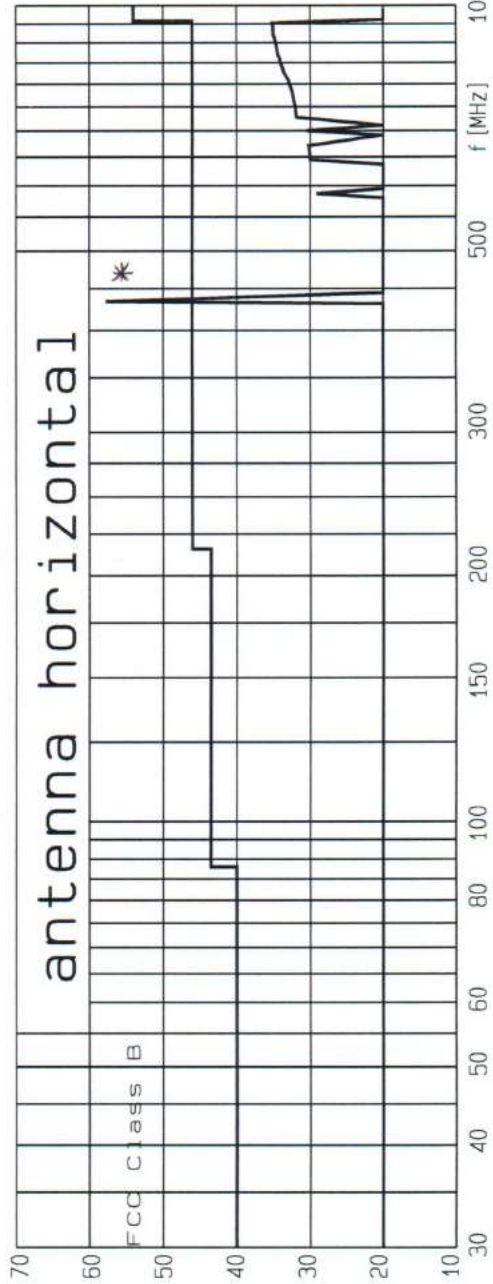
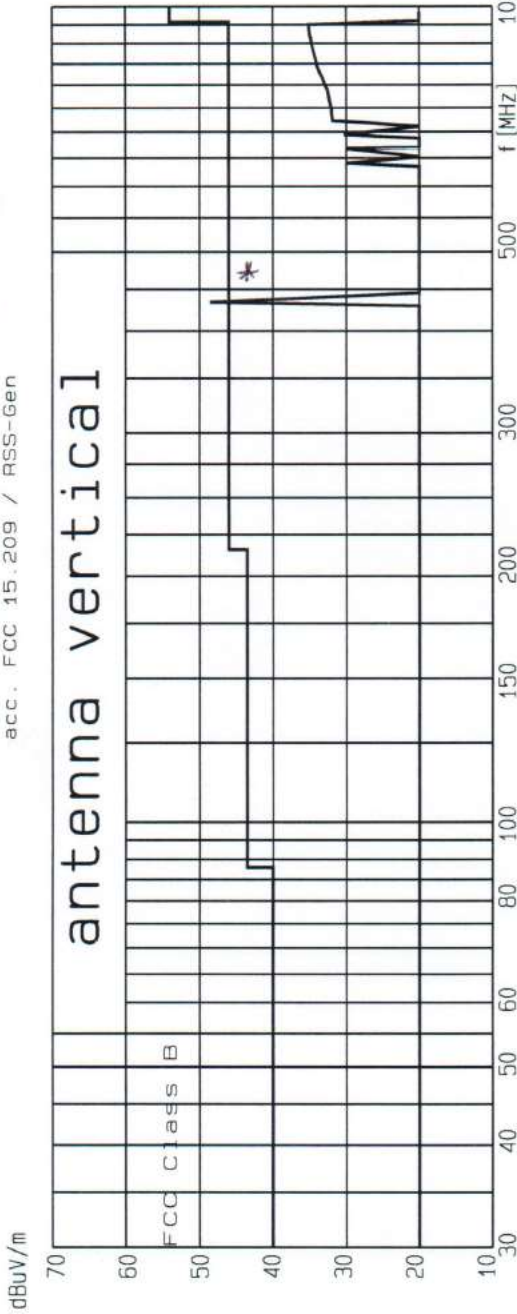

Result: pass  fail ( )

the highest points found:

freq. [MHz]	tested [dBuV/m]	limit [dBuV/m]	pol. [h/v]
433.92	48.57	46	v *
950.24	35.11	46	v
937.16	35.08	46	v
921.32	34.97	46	v
913.32	34.84	46	v
433.92	57.75	46	h *
951.64	35.14	46	h
942.44	35.05	46	h
920.52	35	46	h
909	34.79	46	h

\* - IF ANY MEANS: EMISSION NOT COUNTED FOR JUDGEMENT.

The six highest emissions for each polarization (H/V) in the frequency range 30 MHz – 1000 MHz are as following:

Frequency [MHz]	Detector	Antenna polarization	Radiated emission [dB $\mu$ V/m]	Radiated emission [ $\mu$ V/m]	Limit [dB $\mu$ V/m] (3 m)	Limit [ $\mu$ V/m] (3 m)	Result
(1)	(2)	(3)	(4)	(5)	(6)	(7)	(8)
950.24	QP	V	35.11	56.95	46.00	200	Pass
937.16	QP	V	35.08	56.75	46.00	200	Pass
921.32	QP	V	34.97	56.04	46.00	200	Pass
913.32	QP	V	34.84	55.21	46.00	200	Pass
-/-	QP	V	-/-	-/-	-/-	-/-	-/-
-/-	QP	V	-/-	-/-	-/-	-/-	-/-
951.64	QP	H	35.14	57.15	46.00	200	Pass
942.44	QP	H	35.05	56.56	46.00	200	Pass
920.52	QP	H	35.00	56.23	46.00	200	Pass
909.00	QP	H	34.79	54.89	46.00	200	Pass
-/-	QP	H	-/-	-/-	-/-	-/-	-/-
-/-	QP	H	-/-	-/-	-/-	-/-	-/-

- (1) = test frequency
- (2) = used detector - quasi peak (QP), peak (PK), average (AV)
- (3) = polarization of the test antenna (Horizontal/Vertical)
- (4) = Reading of test receiver + conversion factor
- (5) =  $10^{((\text{Radiated emission [dB}\mu\text{V/m] (5)})/20)}$
- (6) = relevant limit in dB $\mu$ V/m
- (7) = relevant limit in  $\mu$ V/m
- (8) = comparison between Limit [dB $\mu$ V/m] (6) and Radiated emission [dB $\mu$ V/m] (4)

**Result 1 GHz – 7 GHz**



**IT 5/6**

**Interference radiation**  
acc. to FCC § 15.209 / RSS-Gen



Ref.-No.: 20/03-0044

Product: Transmitting/Receiving System

Sample: 06

Date: 14.04.2020

Operator: BI

Remarks: HPF (11735) used

pass fail

Result:

Operation mode: Transmitting 433,92MHz; Receiving 125kHz

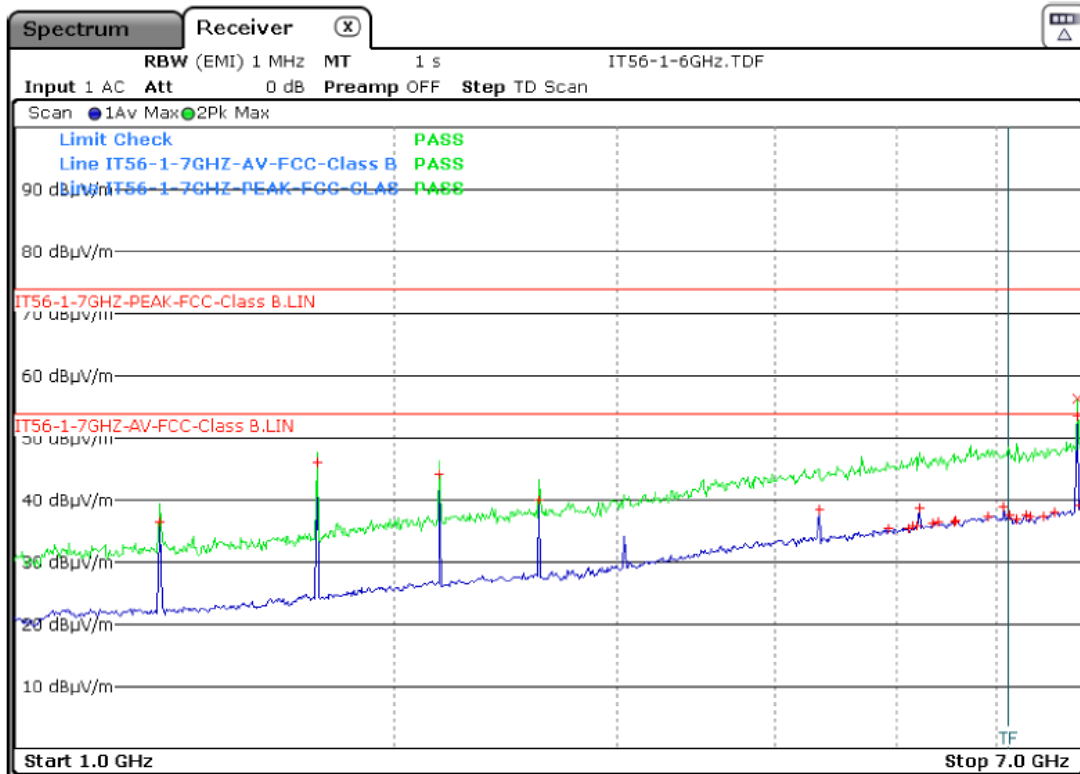

Polarisation: V									
Detector Average					Detector Peak				
Frequ. [GHz]	Level [dBµV/m]	Margin to Limit [dB]	Limit [dBµV/m]	Result	Frequ. [GHz]	Level [dBµV/m]	Margin to Limit [dB]	Limit [dBµV/m]	Result
6,9430	53,46	-0,54	54,00	pass	6,9430	56,36	-17,64	74,00	pass
1,7358	46,12	-7,88	54,00	pass					
2,1698	44,13	-9,87	54,00	pass					
2,6035	40,09	-13,91	54,00	pass					
6,9953	39,18	-14,82	54,00	pass					
6,9870	39,12	-14,88	54,00	pass					



**IT 5/6**  
Interference radiation  
acc. to FCC § 15.209 / RSS-Gen



Ref.-No.: 20/03-0044

Operation mode: Transmitting 433,92MHz; Receiving 125kHz

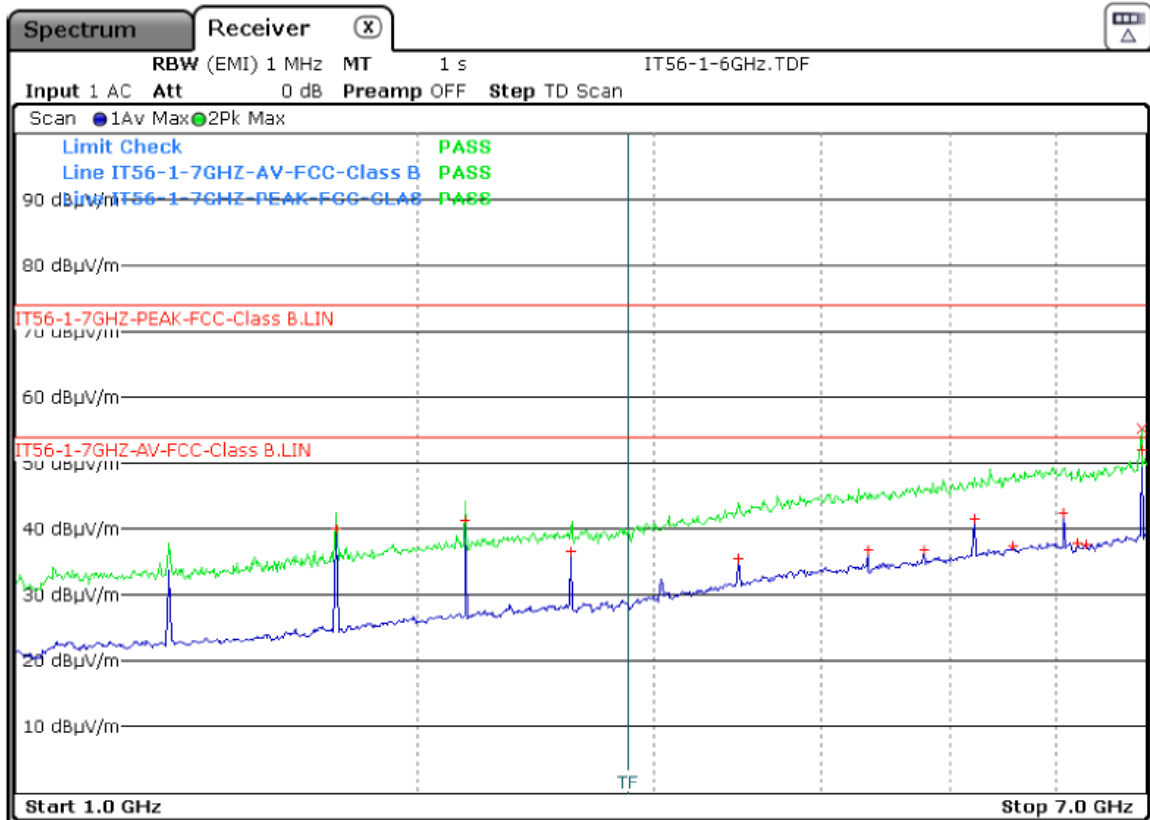

Polarisation: H									
Frequ. [GHz]	Level [dBµV/m]	Detector Average			Detector Peak				
		Margin to Limit [dB]	Limit [dBµV/m]	Result	Frequ. [GHz]	Level [dBµV/m]	Margin to Limit [dB]	Limit [dBµV/m]	Result
6,9430	51,97	-2,03	54,00	pass	6,9430	55,17	-18,83	74,00	pass
6,0750	42,34	-11,66	54,00	pass					
5,2070	41,62	-12,38	54,00	pass					
2,1695	41,31	-12,69	54,00	pass					
1,7358	39,99	-14,01	54,00	pass					
6,2248	37,75	-16,25	54,00	pass					

**Results**

From the measurement data obtained, the tested sample was considered to have **COMPLIED** with the requirements for the **Radiated Emissions**.

## 7. Output Power of Fundamental Emission

### Applied standards

- e-CFR Title 47 Chapter I Subchapter A Part 15 Subpart C, § 15.231 (b)
- RSS-210 Issue 10 Annex A 1.2

### Test equipment and test set up

Test equipment used for radiated measurements as given in clause Test equipment of this report.  
 Test setup used for radiated measurements as given in clause Test setups of this report.

### Limits

Frequency MHz	Limit [dBµV/m]	Limit [µV/m]	Limit [dBµV/m] @ 433.92 MHz	Limit [µV/m] @ 433.92 MHz	Test distance [m]
40,66 - 40,70	67	2250	-/-	-/-	3
70 – 130	62	1250	-/-	-/-	3
130 – 174	62 to 71,4 *	1250 to 3750*	-/-	-/-	3
174 – 260	71,4	3750	-/-	-/-	3
260 – 470	71,4 to 81,9 *	3750 to 12500 *	80,83	10998,45	3
Above 470	81,9	12500	-/-	-/-	3

\*Linear interpolation with frequency, f, in MHz:

-For 130-174 MHz: Field Strength (µV/m) = (56.82 x f)-6136

-For 260-470 MHz: Field Strength (µV/m) = (41.67 x f)-7083

### Measurement

The Measurement was performed on: 14.04.2020

Frequency [MHz]	Radiated emission QP [dBµV/m]	Radiated emission QP [µV/m]	Limit [dBµV/m]	Limit [µV/m]	Margin [dB]	Result
433,92	66,3	2065,38	80,83	10998,45	14,53	Pass

Detector - quasi peak (QP), peak (PK), average (AV)

### Results

From the measurement data obtained, the tested sample was considered to have **COMPLIED** with the requirements of **Output Power of Fundamental Emissions**.



## 8. 99% Power Bandwidth

### Applied standards

-RSS-Gen issue 5 Section 6.7

### Test equipment and test set up

Test equipment used for conducted measurements as given in clause Test equipment of this report.  
Test setup used for conducted measurements as given in clause Test setups of this report.

### Description

The occupied bandwidth is the frequency bandwidth such that, below its lower and above its upper frequency limits, the mean powers are each equal to 0.5% of the total mean power of the given emission. The 99% power bandwidth function of the instrument was used for the measurement.

### Measurement

The Measurement was performed on: 02.06.2020

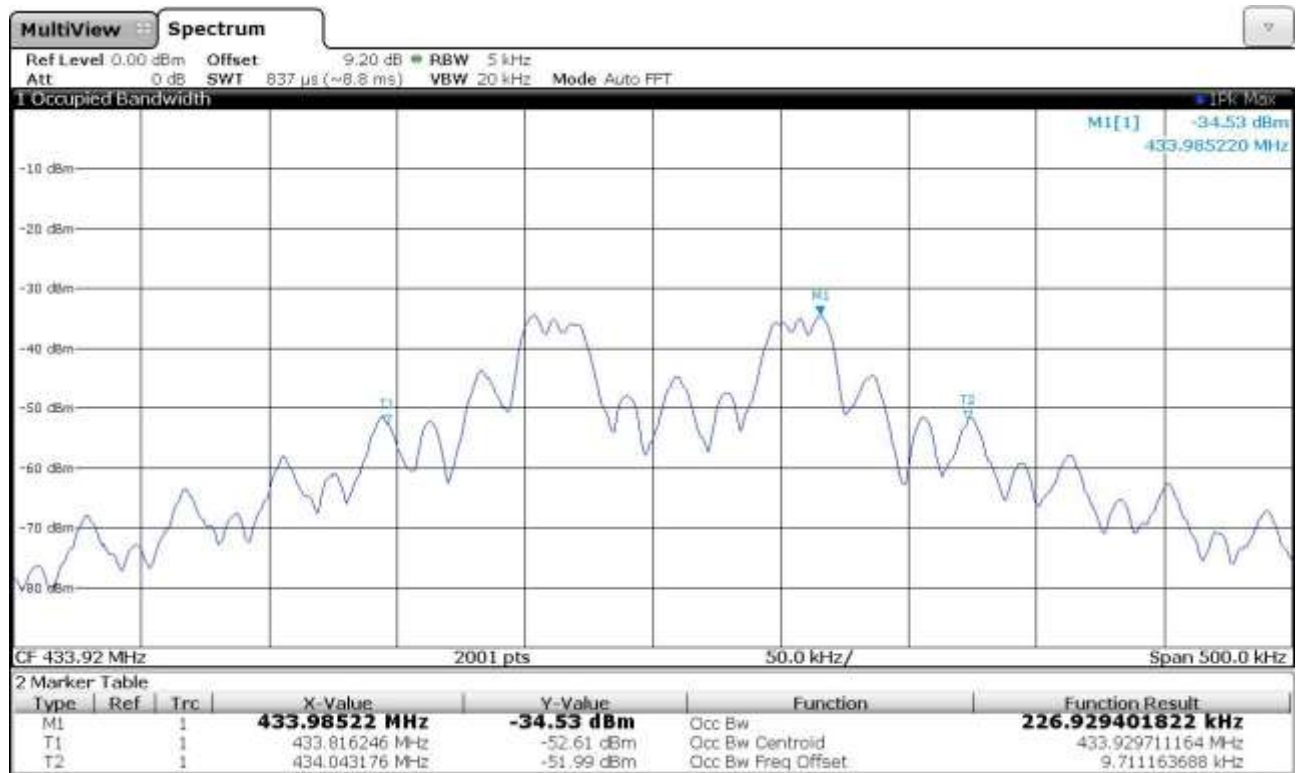

### Results

From the measurement data obtained, the tested sample was considered to have **COMPLIED** with the requirements for the **99% Power Bandwidth**.

## 9. 20 dB Bandwidth

### Applied standards

- e-CFR Title 47 Chapter I Subchapter A Part 15 Subpart C, § 15.231 (c)
- RSS-210 Issue 10 Annex A 1.3

### Test equipment and test set up

Test equipment used for conducted measurements as given in clause Test equipment of this report.  
Test setup used for conducted measurements as given in clause Test setups of this report.

### Description

The bandwidth is measured at an amplitude level reduced from the reference level by a specified ratio. The reference level is the level of the highest amplitude signal observed from the transmitter at the fundamental frequency. Once the reference level is established, the equipment is conditioned with typical modulating signal to produce the worst-case (i.e. the widest) bandwidth.

### Limits

The occupied bandwidth of momentarily operated devices shall be less than or equal to 0.25% of the centre frequency for devices operating between 70 MHz and 900 MHz. For devices operating above 900 MHz, the occupied bandwidth shall be less than or equal to 0.5% of the centre frequency.

Frequency [MHz]	20 dB BW limit [%]
70 - 900	0,25
Above 900	0,50

**Measurement**

The Measurement was performed on: 22.04.2020

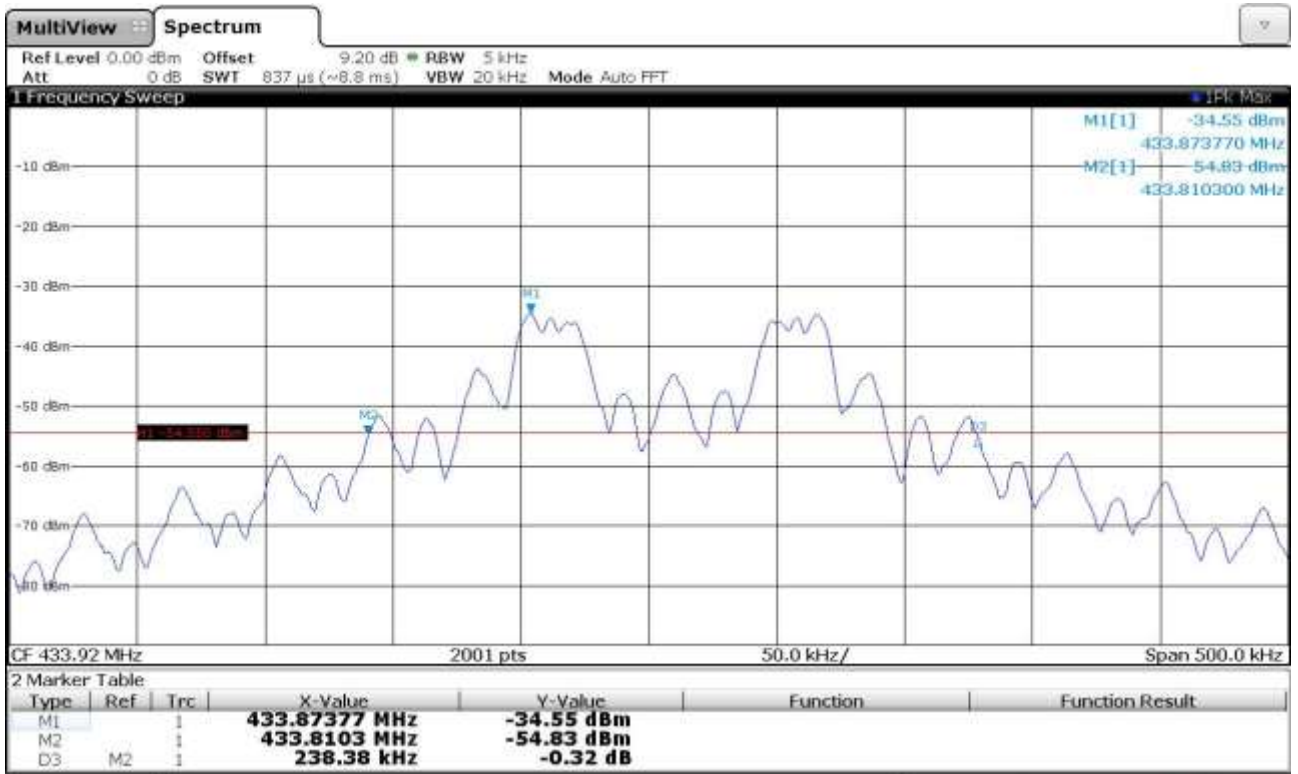

**Summery List of Bandwidth**

EUT Frequency (MHz)	20 dB Bandwidth [kHz]	Limit for 433,92 MHz (f * 0,0025) [kHz]	Result
433,92	238.38	1084,8	Pass

**Results**

From the measurement data obtained, the tested sample was considered to have **COMPLIED** with the requirements for the **20 dB Bandwidth**.

## 10. Periodic Operation

### Applied standards

- e-CFR Title 47 Chapter I Subchapter A Part 15 Subpart C, § 15.231 (a)
- RSS-210 Issue 10 Annex A 1.1

### Test equipment and test set up

Test equipment used for conducted measurements as given in clause Test equipment of this report.  
Test setup used for conducted measurements as given in clause Test setups of this report.

### Description

- A manually operated transmitter shall be equipped with a push-to-operate switch and be under manual control at all times during transmission. When released, the transmitter shall cease transmission within no more than 5 seconds of being released.
- A transmitter that has been activated automatically shall cease transmission within 5 seconds of activation.

### Measurement

The Measurement was performed on: 06.08.2020

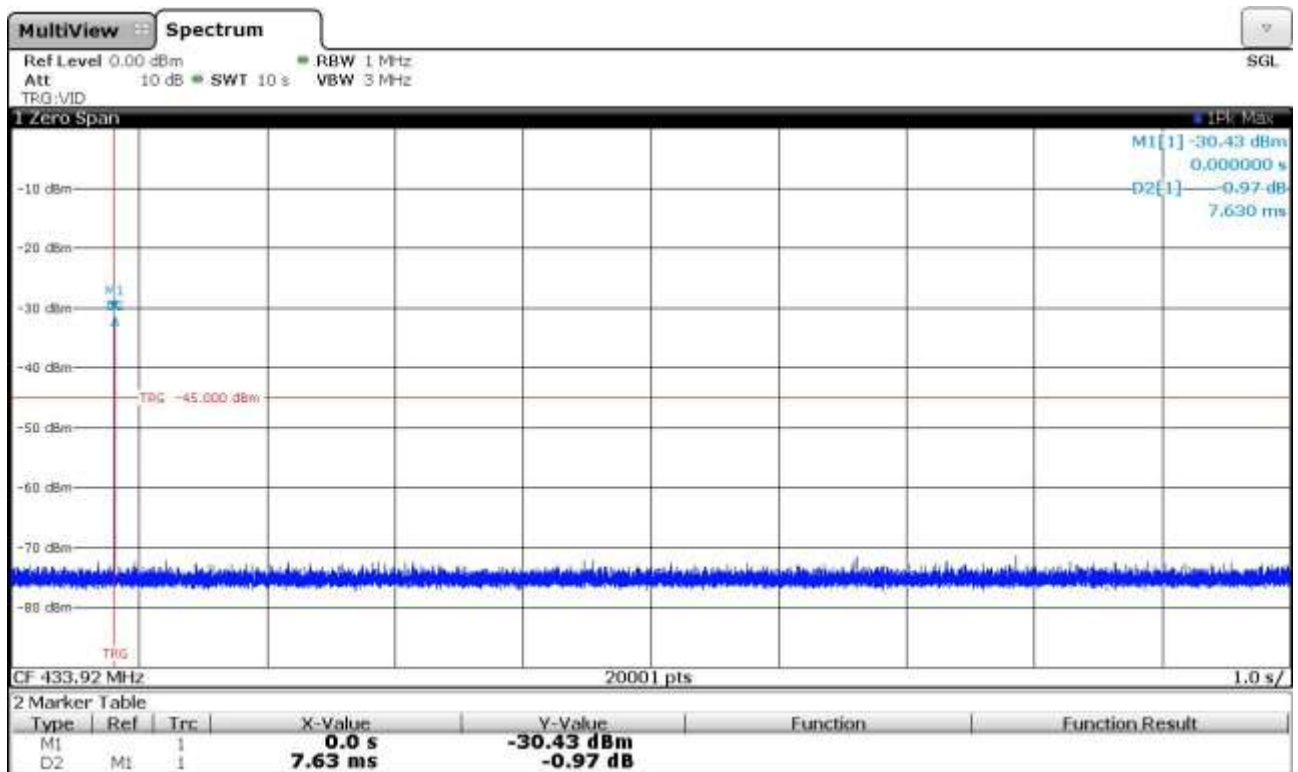

Activation of Transmission (respond to LF challenge).

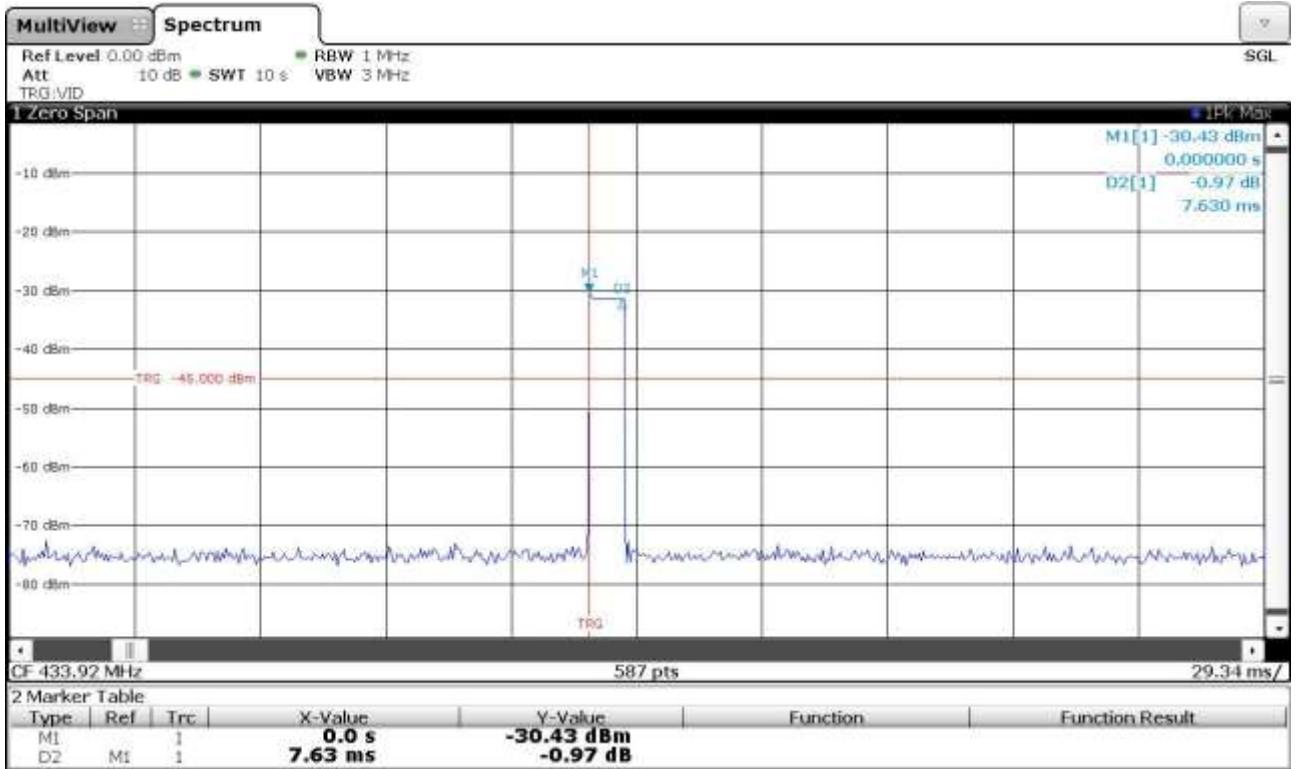

Transmission detail (single message)

**Operating time:**

EUT Frequency (MHz)	T <sub>on</sub> (s)	Limit T <sub>on</sub> (s)	T observation (s)	Result	Comment
433.920	0.00763	5	10	PASS	Transmission is finished within less than 5 sec. of being released

**Remark**

The keyfob transmits (respond to LF challenge) only one single message of 146 bits that lasts 7.6 ms. There is no any other type of automatic or periodic transmission from keyfob without LF challenge (LF = 125 kHz).

**Results**

From the measurement data obtained, the tested sample was considered to have **COMPLIED** with the requirements for the **Periodic Operation**.

## 11. Test equipment

### Test equipment used for radiated Measurements:

Kind of equipment	Manufacturer	Type	Ident no.	Serial no.	Calibrated on (y-m)	Calibration interval
Signal Spectrum Analyzer 2Hz – 26.5 GHz	Rohde & Schwarz	FSW 26 Instrument FW 2.60	11571	102047	2019-Jan.	3 years
ESR7 EMI Testreceiver 7GHz	Rohde & Schwarz	ESR7	11676	101694	2018-March	3 years
Test-Receiver	Rohde & Schwarz	ESVS30	10572	833825/010	2017-March	3 years
					2020-April	3 years
Antenna 9 kHz – 30 MHz	EMCO	6502	10546	2018	2017-Nov.	3 years
Antenna 30 MHz – 1 GHz	Chase	CBL6111C	10022	1064	2019-Dec.	3 years
Antenna 1GHz – 18 GHz	Electro Metric	RGA50/60	10273	2753	2017-Nov.	3 years
Broadband-Preamplifier 1-18 GHz	Schwarzbeck	BBV9718	11231	9718-002	2017-Okt.	3 years
Cable	el-spec GmbH	FlexCore-SMA11-SMA11-8000-ARM	11625	-/-	2017-Dec.	3 years
Band Reject Filter	Telemeter	BRF-2450-150-7-N (0441)	11243	-/-	-/-	-/-
Shielded room/Chamber	Frankonia	SAC3 "SEMI-ANECHOIC-CHAMBER"	11609	004/16	2019-March	3 years

**Test equipment used for conducted measurements:**

Kind of equipment	Manufacturer	Type	Ident no.	Serial no.	Calibrated on (y-m)	Calibration interval
Signal Spectrum Analyzer 2Hz – 26.5 GHz	Rohde & Schwarz	FSW 26 Instrument FW 2.60	11571	102047	2019 - Jan.	3 years
EMI-Test-Receiver	Rohde & Schwarz	ESR7 Instrument FW 3.36	11505	101103	2017 - Nov.	3 years
Automatisation unit RF switch and power meter	Rohde & Schwarz	OSP120 and OSP B157	11573	101282	2017 - Dec.	3 years
Cable	el-spec GmbH	FlexCore-SMA11-SMA11-8000-ARM	11625	-/-	2017 - Dec.	3 years

All measurements were made with measuring instruments, including any accessories that may affect test results, calibrated according to the requests of ISO/IEC 17025 according to which the test site is accredited from DAkkS. Measurement of conducted emissions was made with instruments conforming to American National Standard Specification, ANSI C63.4-2014.

**Test equipment to support EUT functions:**

Kind of equipment	Manufacturer	Type	Ident no.
Immobilizer Control Unit Set with Antennas and Control Unit (BCM FI7) on one board mounted	APTIV	HOMOLOGATION SETUP 3	-/-
Power supply	Elektro-Automatik	EA-3021S	10375
-/-	-/-	-/-	-/-

## 12. Test Setups

### Block diagram Radiated emissions

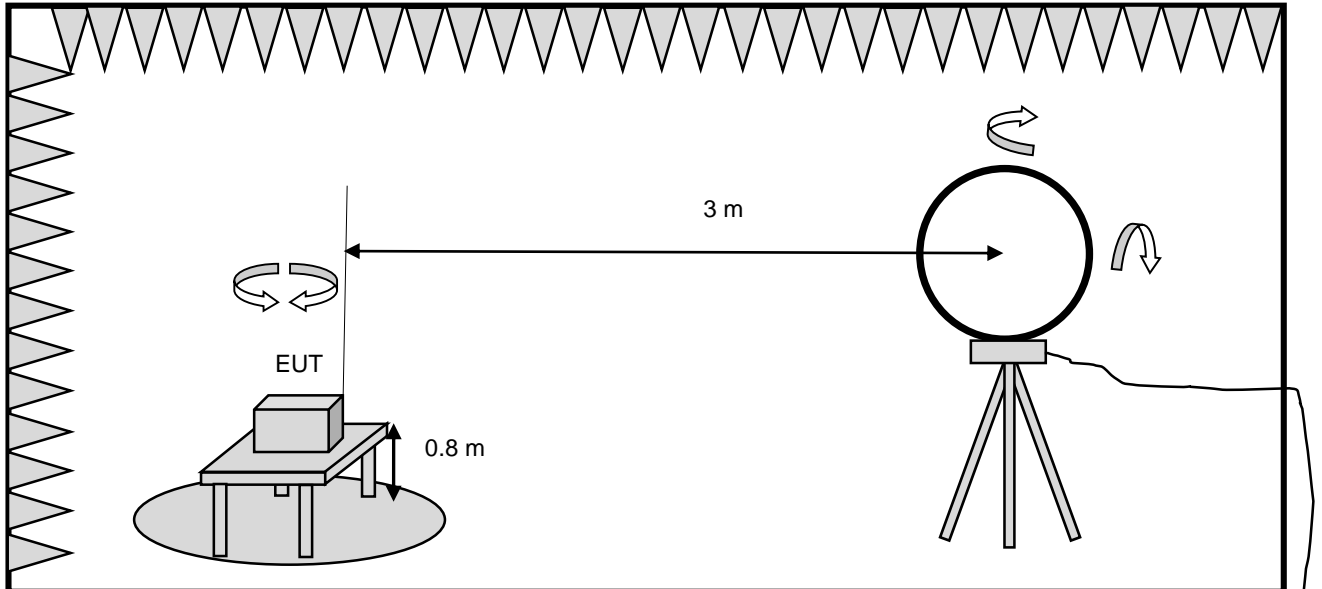

Semi anechoic chamber with absorber and ferrite tiles

tested frequency range 9 kHz - 30 MHz

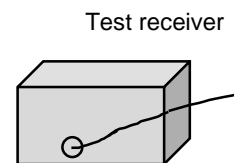

### Block diagram Radiated emissions

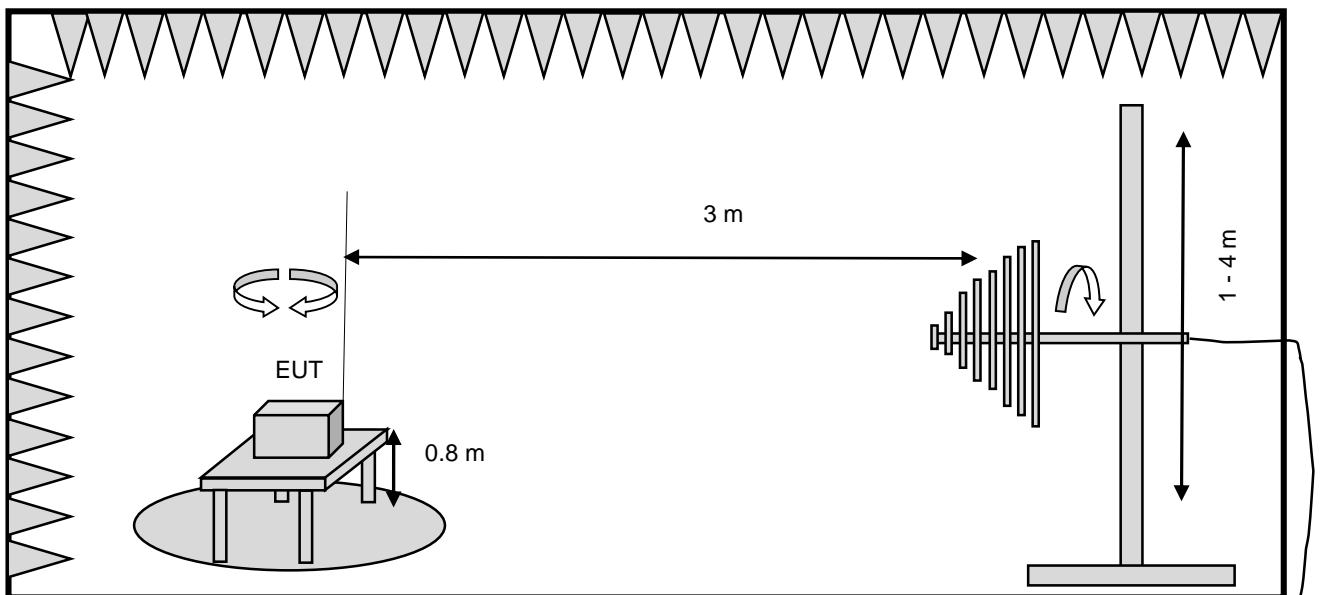

Semi anechoic chamber with absorber and ferrite tiles

tested frequency range 30 MHz - 1000 MHz

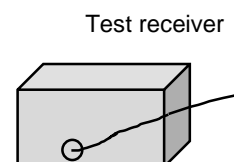



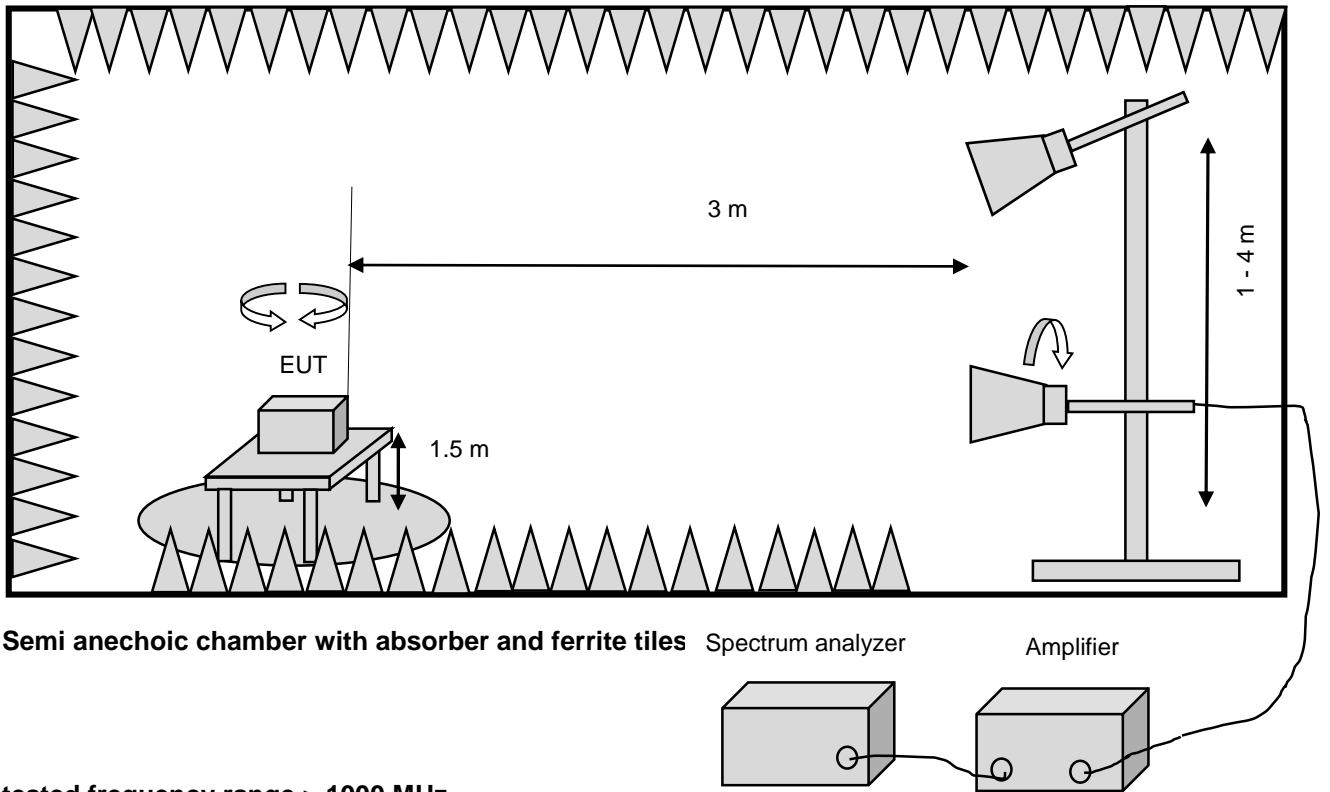

**Block diagram for conducted measurements**

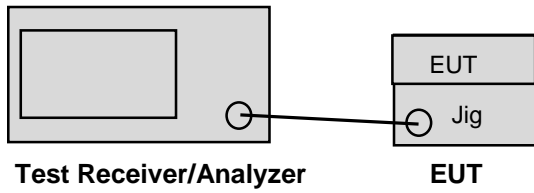

### 13. Measurement uncertainty

according to CISPR 16-4-2 Edition 2.0 2011-06

Measurement	calculated uncertainty $U_{lab}$	Specified CISPR uncertainty according CISPR 16-4-2 Edition 2.0 2011-06, table 1 $U_{CISPR}$
Conducted disturbance at mains port using AMN 9 kHz – 150 kHz	3.6 dB	3.8 dB
Conducted disturbance at mains port using AMN 150 kHz – 30 MHz	3.2 dB	3.4 dB
Magn. fieldstrength 9kHz - 30MHz	3.4 dB	-/-
Radiated disturbance (electric field strength in the SAC) 30 MHz to 1 000 MHz	4.7 dB	6.3 dB
Radiated disturbance (electric field strength in the SAC) 1 GHz to 26.5 GHz	4.1 dB	-/-

Measurement	calculated uncertainty $U_{lab}$	Maximum measurement uncertainty
Channel Bandwidth	1.17 %	±5 %
RF output power, conducted	±1.36 dB	±1.5 dB
Power Spectral Density, conducted	±1.99 dB	±3 dB
Unwanted Emissions, conducted	±1.71 dB	±3 dB
All emissions, radiated	±4.8 dB	±6 dB
Temperature	±0.72 °C	±3 °C
Supply voltages	±0.76 % (DC up to 40V) ±1.74 % (AC 50Hz up to 400V)	±3 %
Time	±0.012 %	±5 %

The measurement uncertainty describes the overall uncertainty of the given measured value during the operation of the EUT in the above mentioned way.

The measurements uncertainty was calculated in accordance with CISPR 16-4-2 Edition 2.0 2011-06.

The measurement uncertainty was given with a confidence of 95 % ( $k = 2$ ).

## **14. Photos setup**

Refer to "0044-fcc-ised-photos test setup.pdf" file

## 15. Conclusions

From the measurement data obtained, the tested sample was considered to have **COMPLIED** with the requirements for the relevant §15.209 Radiated emission limits; general requirements, §15.231 Periodic operation in the band 40.66-40.70 MHz.

From the measurement data obtained, the tested sample was considered to have **COMPLIED** with the requirements for the relevant RSS-210 issue 10 Digital Licence-Exempt Radio Apparatus: Category I Equipment.

Following specific modifications and/or special attributes are necessary to pass the above mentioned requirements:

none

This test report replaces the test report no. 20/03-0044 dated 06.08.2020.

09.11.2020

Erstellt am/prepared on

A. Tropmann, Test Engineer

(Name/name / Stellung/position)



(Unterschrift/signature)

09.11.2020

Freigabe am/released on

K. Simon, Deputy Head of Laboratory

(Name/name / Stellung/position)



(Unterschrift/signature)

## **16. Photos of tested sample**

Refer to "0044-fcc-ised-photos EUT.pdf" file

**End of test report**