



***Test Report No. 9012300934***

***Applicant: ElmoTech Ltd.***

***Equipment Under Test:***

***Repeater***

***Model: iDEU-830-4***

***FCC ID: LSQ-IDEU-830-4***

***From The Standards Institution  
Of Israel  
Industry Division  
Electronics & Telematics Laboratory  
EMC Section***



**Test Report No.:** 9012300934

Page 1 of 25 pages

**Title:** Test on Repeater**FCC ID:** LSQ-IDEU-830-4**Model:** iDEU-830-4

<b>Applicant:</b>	Elmotech Ltd.
<b>Address:</b>	2 Habarzel Street, POB 13236, Tel-Aviv, Israel
<b>Sample for test selected by:</b>	The customer
<b>The date of test:</b>	11, 13 January 2010

<b>Description of Equipment Under Test (EUT):</b>	Repeater
<b>Model:</b>	iDEU-830-4
<b>Serial Number:</b>	1209
<b>Software version</b>	5.1
<b>Hardware version</b>	1.2
<b>Manufactured by:</b>	Elmotech Ltd

**Reference Documents:**

- ❖ CFR 47 FCC: Rules and Regulations; Part 15. "Radio frequency devices";  
Subpart C: "Intentional radiators" (2007),  
Section 15.205. "Restricted bands of operations",  
Section 15.209. "Radiated emission limits, general requirements".  
"Radiated Emission Limits, Additional Provisions";  
Section 15.231. "Periodic operation in the bands 40.66 – 40.70 MHz,  
and above 70 MHz".

This Test Report contains 25 pages and may be used only in full.	This Test Report applies only to the specimen tested and may not be applied to other specimens of the same product.
---	--



**Test Report No.:** 9012300934

**Page 2 of 25 pages**

**Title:** Test on Repeater

**FCC ID:** LSQ-IDEU-830-4

**Model:** iDEU-830-4

## **Table of Contents**

<b>1. EUT Description and operation</b>	<b>3</b>
1.1. General description:	3
<b>2. Test summary</b>	<b>5</b>
2.1. Potential emission sources:	8
2.2. EUT setup and operation:	8
<b>3. Measurements, examinations and derived results</b>	<b>8</b>
3.1. Location of the Test Site:	8
3.2. Test condition:	8
3.3. Initial visual check and functional test:	8
3.4. Radiated emission test.	9
3.5. Common conditions for operation in the band above 70MHz.	10
3.6. Test of field strength emission from intentional radiator.	11
3.7. Test of occupied bandwidth per 15.231(c)	19
3.8. Test of conducted emission at main terminal.	20
<b>4. Appendix 1. Test equipment used</b>	<b>22</b>
<b>5. Appendix 2: Antenna Factor and Cable Loss</b>	<b>23</b>

**Test Report No.:** 9012300934**Page 3 of 25 pages****Title:** Test on Repeater**FCC ID:** LSQ-IDEU-830-4**Model:** iDEU-830-4

## 1. EUT Description and operation

### 1.1. General description:

\* Note: the customer supplied all information in clause below.

The iDEU-830-4 is a wall or table-top mounted device for use in various offender presence monitoring applications.

The unit is primarily designed as a repeater to extend the range of bracelet transmitters attached to the ankle of the person monitored by the system. Transmissions received by the iDEU-830-4 are forwarded to a home unit installed at the offender's home. Violations to the offender's curfew schedule generate events that are uploaded to the central monitoring station via various communication interfaces.

Declare maximum EIRP power:	-2 dBm@ 418 MHz
Type of modulation:	GFSK
Antenna type:	Helical antenna

Power source: External AC/DC 12V power supply ElmoTech model SE 120100 and internal redundancy 3.6 Volt Li-Ion battery.

The EUT's block diagram is shown in Figures 1

External and internal views are presented in Photo #1.

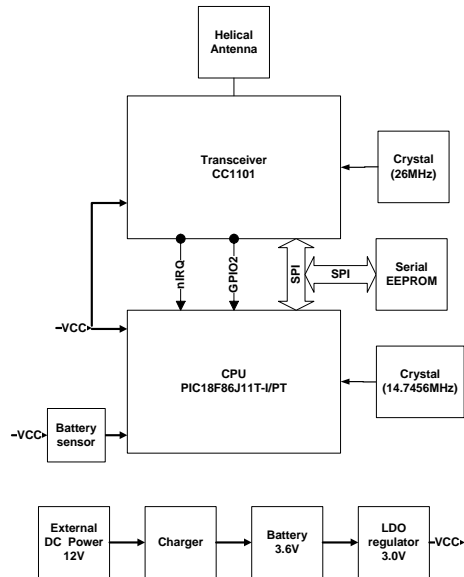

**Figure 1. Repeater block diagram.**

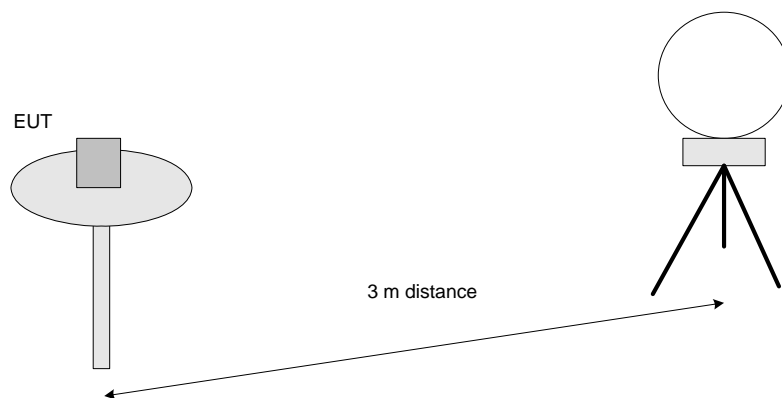

**Figure 2. Radiated emission test setup diagram.**

**Test Report No.:** 9012300934

Page 5 of 25 pages

**Title:** Test on Repeater**FCC ID:** LSQ-IDEU-830-4**Model:** iDEU-830-4

## 2. Test summary

Parameter	FCC Part 15 Reference paragraph	Comply/not comply with the requirements
Radiated emission test.	Subpart C Section 15.209	Comply
Test of field strength emission from intentional radiators	"Radiated Emission Limits, Additional Provisions"; Section 15.231(b).	Comply
Occupied bandwidth	Subpart C Section 15.231(c)	Comply
Conducted emission test	Subpart C Section 15.207(a)	Comply

Name: Eng. Yuri Rozenberg  
Position: Head of EMC Branch

Telematics  
Laboratory

January 2010

Name: Michael Feldman  
Position: Test Technician



**Test Report No.:** 9012300934

**Page 6 of 25 pages**

**Title:** Test on Repeater

**FCC ID:** LSQ-IDEU-830-4

**Model:** iDEU-830-4



**Photo 1. EUT's external and internal view**

**Test Report No.:** 9012300934

**Page 7 of 25 pages**

**Title:** Test on Repeater

**FCC ID:** LSQ-IDEU-830-4

**Model:** iDEU-830-4



**Photo 2. Spurious emissions test setup.**



**Photo 3. Spurious emissions investigation test setup.**



**Test Report No.:** 9012300934

Page 8 of 25 pages

**Title:** Test on Repeater**FCC ID:** LSQ-IDEU-830-4**Model:** iDEU-830-4

### 2.1. Potential emission sources:

The potential emission sources are detailed in Table 1.

**Table 1. Potential emission sources**

Frequency	Location
14.7456 MHz crystal	CPU PIC18F86J11
26.0 MHz crystal	Transceiver CC1101
418 MHz RF signal	Base unit

### 2.2. EUT setup and operation:

Respective tests were performed in Transmission (Tx) and Receive modes. Measurements of transmitter were performed in continue transmission mode.

## 3. Measurements, examinations and derived results

### 3.1. Location of the Test Site:

Preliminary radiated test was conducted at the EMC laboratory of the Standards Institution of Israel in Tel-Aviv.

Final tests were conducted in an Open Area Test Site located at Kibbutz Native Halamed Hai in Emek HaEla, Israel.

### 3.2. Test condition:

Temperature: 20 °C. Humidity: 57 %. Atmospheric pressure: 1009 mbar.

### 3.3. Initial visual check and functional test:

Initial visual check and brief built- in- test of the EUT was performed before testing.

- No external damages were found.
- The test on the EUT passed successfully.

**Test Report No.:** 9012300934

Page 9 of 25 pages

**Title:** Test on Repeater**FCC ID:** LSQ-IDEU-830-4**Model:** iDEU-830-4

### 3.4. Radiated emission test.

#### 3.4.1. General:

Per FCC Part 15 Subpart C Sections 15.209, 15.231.

- \* Initial scans were made using a peak detector but still using the appropriate ANSI IF bandwidth.
- \* A tolerance limit was set 10 dB below the specification limit. Levels above the tolerance limit were retested using the Peak detector.

#### 3.4.2. Preliminary radiated emission tests:

Preliminary investigation was performed from the lowest radio frequency signal generated in the equipment, without going below 9 kHz and up to ten harmonic of a carrier frequency. Test was conducted in a semi-anechoic chamber at distance 1 and 3 meters. The EUT was setup in its typical configuration and operated in its various modes. For each mode of operation the frequency spectrum was monitored. EUT configuration, cable configuration and mode of operation, which produced the maximum level of emission, were documented. A list of frequencies to be tested was prepared.

#### 3.4.3. Final measurements:

The final radiated emission measurements were performed at the Open Area Test Site at the 3 m test distance. The EUT was operated as described above. The EUT was installed on a turn - table. Biconilog and Double Ridged Guide antennas were used. The measurements were performed at each frequency that founded previously at which the signal level was 10 dB below the limit or less. The levels were maximized by rotating turntable through 360° and changing antenna-to-EUT polarization from vertical to horizontal. The worse case result was noted in tables.

#### 3.4.4. Radiated emission test results:

Test result in receive mode was found below SA noise floor and at least 15 dB under the section 15.209 specified limit. For plot result in receive mode refer to plots ## 8 - 10  
Final result measurements in transmit mode are presented in tables and plots ## 1 - 7 in section 3.6.5.



**Test Report No.:** 9012300934

**Page 10 of 25 pages**

**Title:** Test on Repeater

**FCC ID:** LSQ-IDEU-830-4

**Model:** iDEU-830-4

### **3.5. Common conditions for operation in the band above 70MHz.**

#### **3.5.1. General:**

Per FCC Part 15 Subpart C clause 15.231 (a).

#### **3.5.2. Requirements:**

15.231(a) – Transmitter is defined as a part of alarm system.

15.231(a)(1) – Transmitter is not activated manually.

15.231(a)(2) – Transmission duration is limited by program and after activation is less than 5 second.

15.231(a)(3) – Transmitter not intended for regular predetermined interval transmissions.

15.231(a)(4) – Transmitter is not operates during the pendency of the alarm conditions.

15.231(a)(5) - Transmitter doesn't exceed the limits of this section.

#### **3.5.3. Summary:**

The EUT is complies with the requirements of clause 15.231(a).

**Test Report No.:** 9012300934

Page 11 of 25 pages

**Title:** Test on Repeater**FCC ID:** LSQ-IDEU-830-4**Model:** iDEU-830-4**3.6. Test of field strength emission from intentional radiator.****3.6.1. General:**

Per FCC Part 15 Subpart C clause 15.231 (b)

**3.6.2. Requirements:**

The EUT's operation frequency is 418 MHz.

The field strength emissions from intentional radiators operated on this frequency shall comply with the limit based on the average value.

**Table 2. Section 15.231(b) limit.**

Fundamental Frequency, MHz	Calculated Field Strength limit of Fundamental dB ( $\mu\text{V/m}$ )	Calculated Field Strength limit of Harmonics dB ( $\mu\text{V/m}$ )
418.0	80.3	60.3

Note: Peak field strength shall not exceed the maximum permitted specified limit by more than 20 dB.

Field strength limits are specified at a distance of 3 meters.

**3.6.3. Test procedure:**

The test was conducted according to clause 15.231.

**3.6.4. Test summary:**

The tested unit meets the standard requirement.

**Test Report No.:** 9012300934

Page 12 of 25 pages

**Title:** Test on Repeater**FCC ID:** LSQ-IDEU-830-4**Model:** iDEU-830-4**3.6.5. Test results:****Table 3. Radiated emission result at carrier frequency.**

Carrier frequency MHz	Antenna polarization V/H	Peak Ampl. dB $\mu$ V/m	Peak Limit dB $\mu$ V/m	Margin dB	Avg Ampl.* dB $\mu$ V/m	Specified @3m limit, dB $\mu$ V/m	Margin dB
418.0	Vertical	93.6	100.3	6.7	68.8	80.3	11.5

\*Average amplitude result was calculated from measured Peak value – Average factor.

For recorded Fundamental frequencies result see plot #1.

All received spurious emissions were found below the specified limit.

Founded spurious emissions results presented in tables below.

**Spurious emissions test result.****Table 4. Spurious emission result.**

Freq. MHz	Antenna polariz. V/H	Peak Ampl. dB $\mu$ V/m	Peak limit dB $\mu$ V/m	Margin dB	Avg Ampl.* dB $\mu$ V/m	Specified @3m limit, dB $\mu$ V/m	Margin dB	Refer. plot
1254	Vertical	50.0	80.3	30.3	25.2	60.3	35.1	#5

\*Average amplitude result was calculated from measured Peak value – Average factor.

Average factor =  $20 \text{ Log Tx on}/100\text{msec} = 20 \text{ Log } [5.7 \text{ ms}/100] = -24.8 \text{ dB}$

For transmitter average factor calculation see plot # 10.





Test Report No.: 9012300934

Page 13 of 25 pages

Title: Test on Repeater

FCC ID: LSQ-IDEU-830-4

Model: iDEU-830-4

09:22:29 11 JAN 2010  
ElmoTech EUT-iDEU-B30-4

ACTV DET: PEAK  
MEAS DET: PEAK QP AVG  
MKR 418.039 MHz  
93.57 dB $\mu$ V

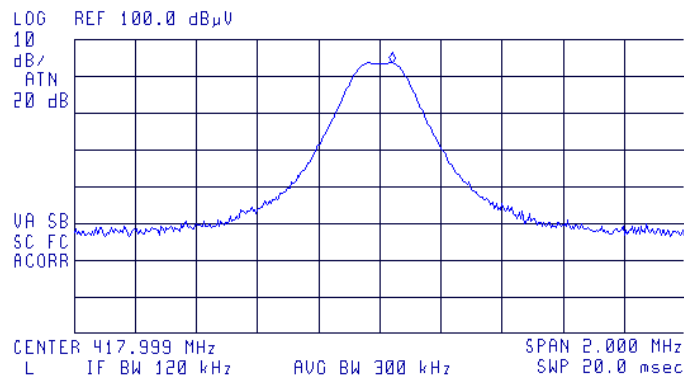

Plot # 1. Field strength of fundamental frequency 418 MHz.

16:22:52 11 JAN 2010  
ElmoTech EUT-iDEU-B30-4

ACTV DET: PEAK  
MEAS DET: PEAK QP AVG  
MKR 14.30 MHz  
16.73 dB $\mu$ V

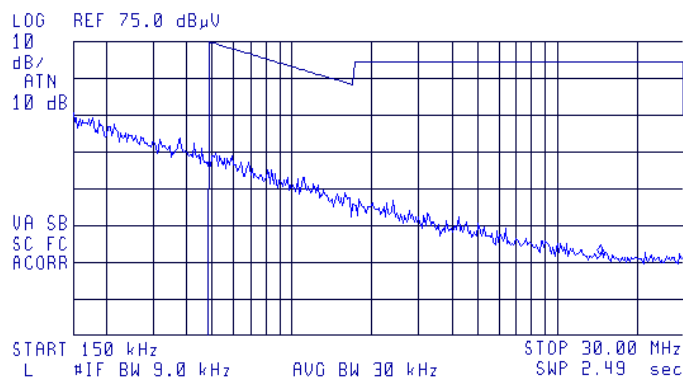

Plot # 2. Spurious emissions scan 0.15 – 30 MHz. Test distance 3m.



Test Report No.: 9012300934

Page 14 of 25 pages

Title: Test on Repeater

FCC ID: LSQ-IDEU-830-4

Model: iDEU-830-4

09:39:52 11 JAN 2010  
ElmoTech EUT-iDEU-B30-4

ACTV DET: PEAK  
MEAS DET: PEAK OP AVG  
MKR 367.1 MHz  
36.68 dBμV

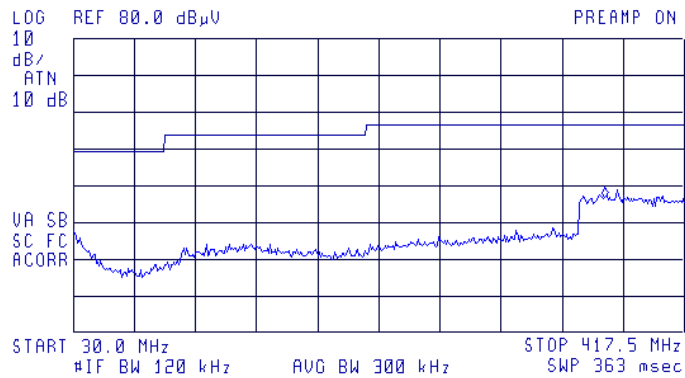

Plot # 3. Spurious emissions scan 30 – 417.5 MHz. Test distance 3m.

09:44:32 11 JAN 2010  
ElmoTech EUT-iDEU-B30-4

ACTV DET: PEAK  
MEAS DET: PEAK OP AVG  
MKR 832.6 MHz  
33.57 dBμV

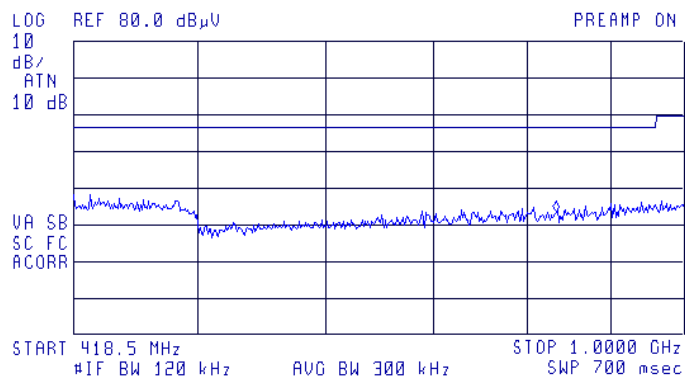

Plot # 4. Spurious emissions scan 418.5 MHz – 1000 MHz.



**Test Report No.:** 9012300934

**Page** 15 of 25 pages

**Title:** Test on Repeater

**FCC ID:** LSQ-IDEU-830-4

**Model:** iDEU-830-4

10:14:10 11 JAN 2010  
ElmoTech EUT-iDEU-B30-4

ACTV DET: PEAK  
MEAS DET: PEAK OP AVG  
MKR 1.257 GHz  
49.25 dB $\mu$ V

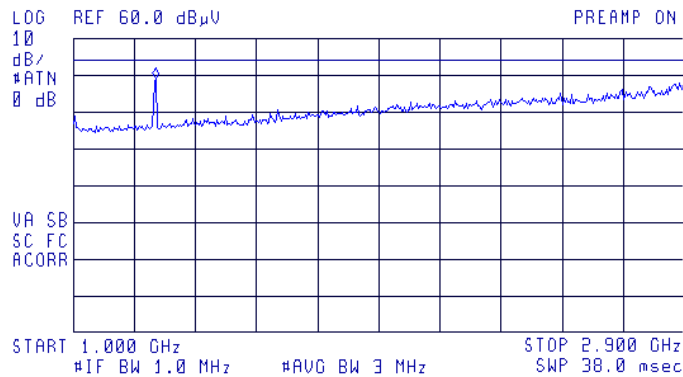

**Plot # 5. Spurious emissions scan at 1.0 – 2.9 GHz frequency range.**

10:09:59 11 JAN 2010  
ElmoTech EUT-iDEU-B30-4

ACTV DET: PEAK  
MEAS DET: PEAK OP AVG  
MKR 1.254000 GHz  
50.00 dB $\mu$ V

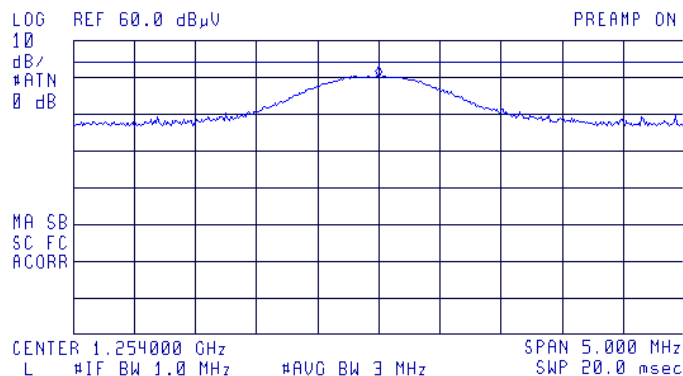

**Plot # 6. The carrier frequency third harmonic. Detector peak.**



**Test Report No.:** 9012300934

**Page 16 of 25 pages**

**Title:** Test on Repeater

**FCC ID:** LSQ-IDEU-830-4

**Model:** iDEU-830-4

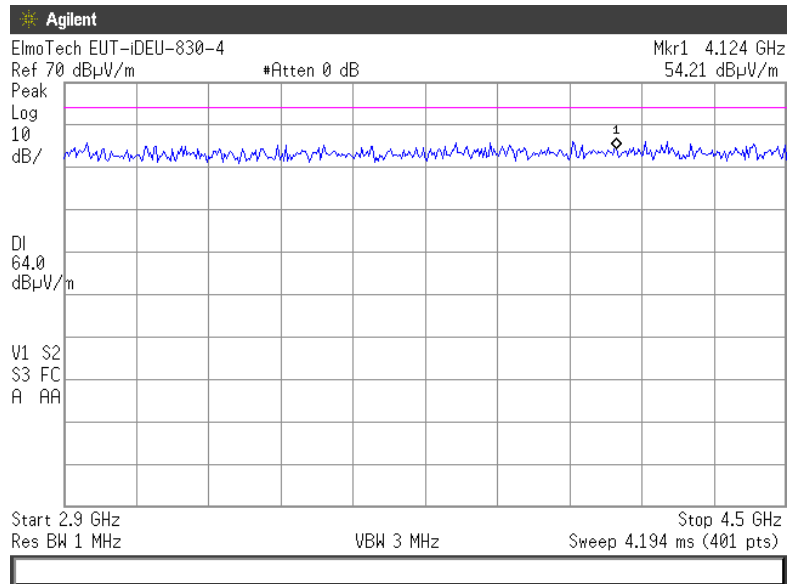

**Plot # 7. Spurious emissions scan at 2.9 – 4.5 GHz frequency range.**



Test Report No.: 9012300934

Page 17 of 25 pages

Title: Test on Repeater

FCC ID: LSQ-IDEU-830-4

Model: iDEU-830-4

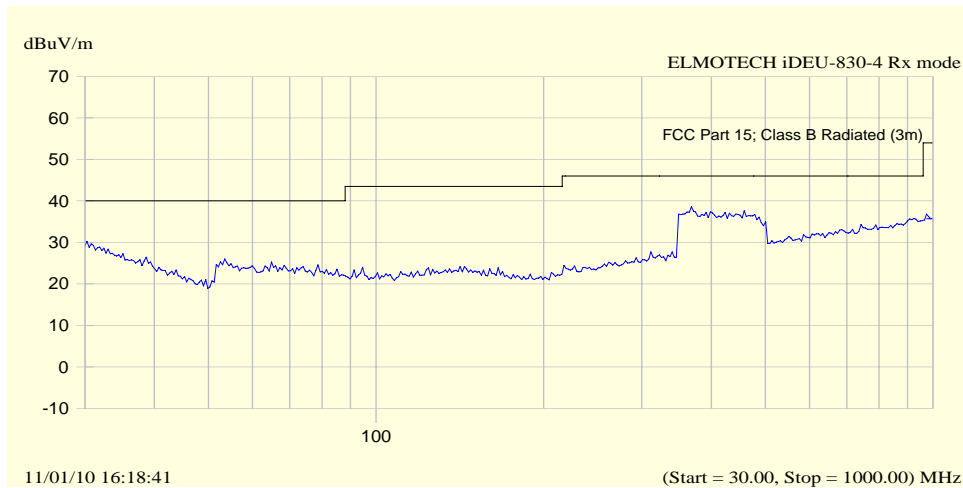

Plot # 8. Radiated emission test in receive mode. Frequency range from 30 MHz to 1000 MHz.

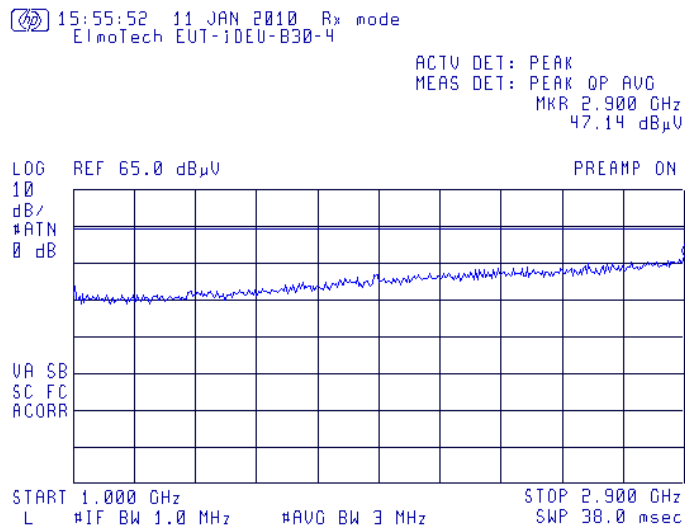

Plot # 9. Scan of spurious emissions in receive mode. Frequency range from 1 GHz to 2.9 GHz.



**Test Report No.:** 9012300934

**Page 18 of 25 pages**

**Title:** Test on Repeater

**FCC ID:** LSQ-IDEU-830-4

**Model:** iDEU-830-4

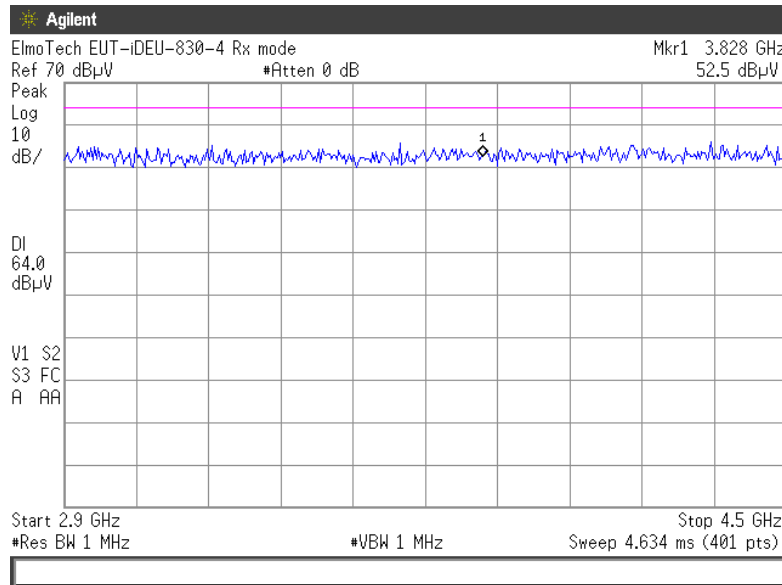

**Plot # 10. Scan of spurious emissions in receive mode. Frequency range from 2.9 GHz to 4.5 GHz.**

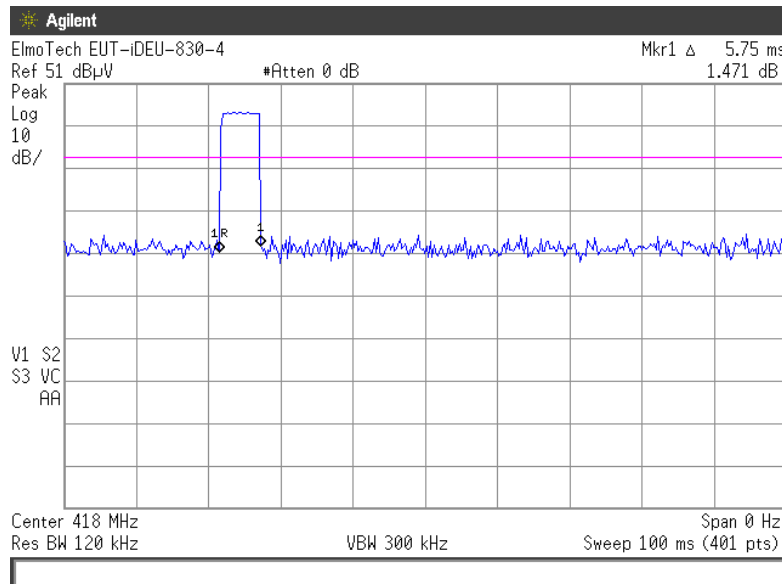

**Plot # 11. Transmission duration - Tx on.**

AVG factor was calculated as  $20 \text{ Log} (\text{Tx on}/100 \text{ msec}) = 20 \text{ Log} [(5.7 \text{ ms})/100] = -24.8 \text{ dB}$

**Test Report No.:** 9012300934

**Page 19 of 25 pages**

**Title:** Test on Repeater

**FCC ID:** LSQ-IDEU-830-4

**Model:** iDEU-830-4

### 3.7. Test of occupied bandwidth per 15.231(c)

#### 3.7.1. Requirements:

The bandwidth of the emissions shall be no wider than 0.25% of the center frequency for devices operating above 70 MHz and below 900 MHz. Bandwidth is determined at the points 20 dB down from the centre of modulated carrier.

For 418 MHz centre frequency allowed occupied bandwidth shall be no more than  $(418/100) \cdot 0.25\% = 1.045$  MHz.

#### 3.7.2. Test results:

Test result presented in plot # 11 below.

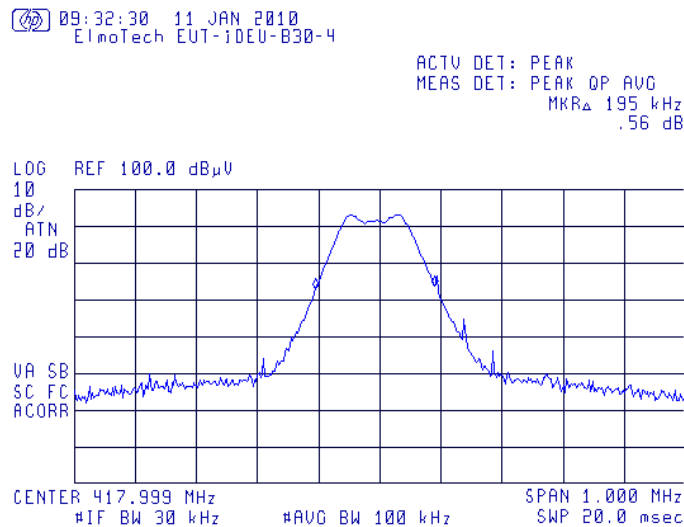

**Plot # 12. Occupied bandwidth test result**

#### 3.7.3. Test summary:

20 dB occupied bandwidth is 195 kHz.  
The tested unit meets the standards requirements.

**3.8. Test of conducted emission at main terminal.**

**3.8.1. General**

Per FCC Part 15 Subpart C clause 15.207 (a)

**3.8.2. Test procedure:**

The test was conducted according to clause 15.207.

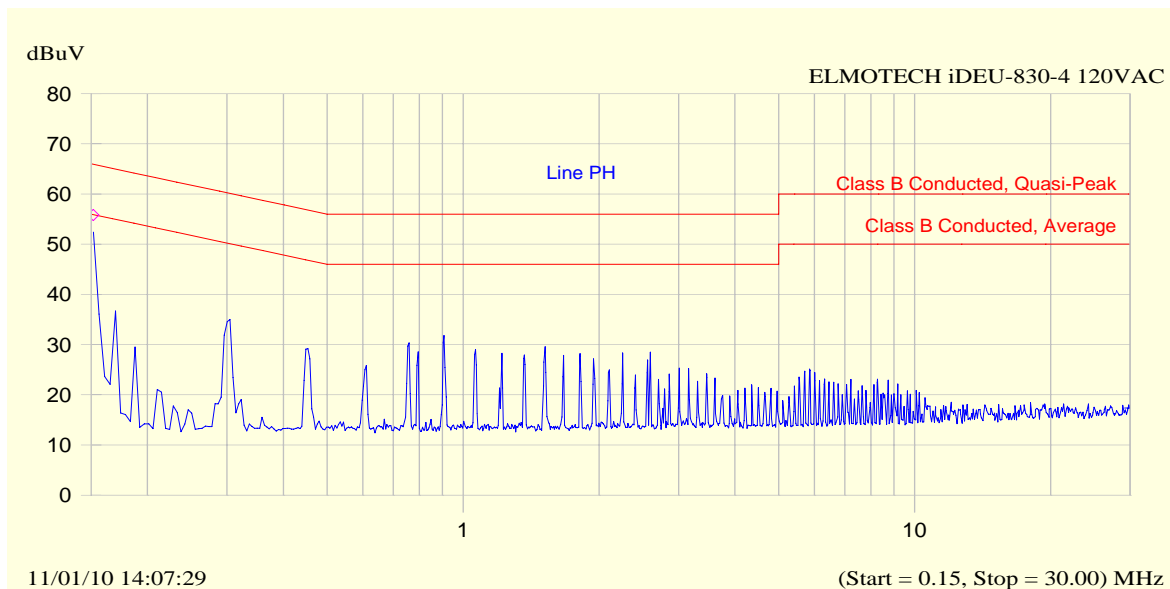

**Table 5. Conducted emission result. Line Phase.**

**Test Report No.:** 9012300934

**Page 21 of 25 pages**

**Title:** Test on Repeater

**FCC ID:** LSQ-IDEU-830-4

**Model:** iDEU-830-4

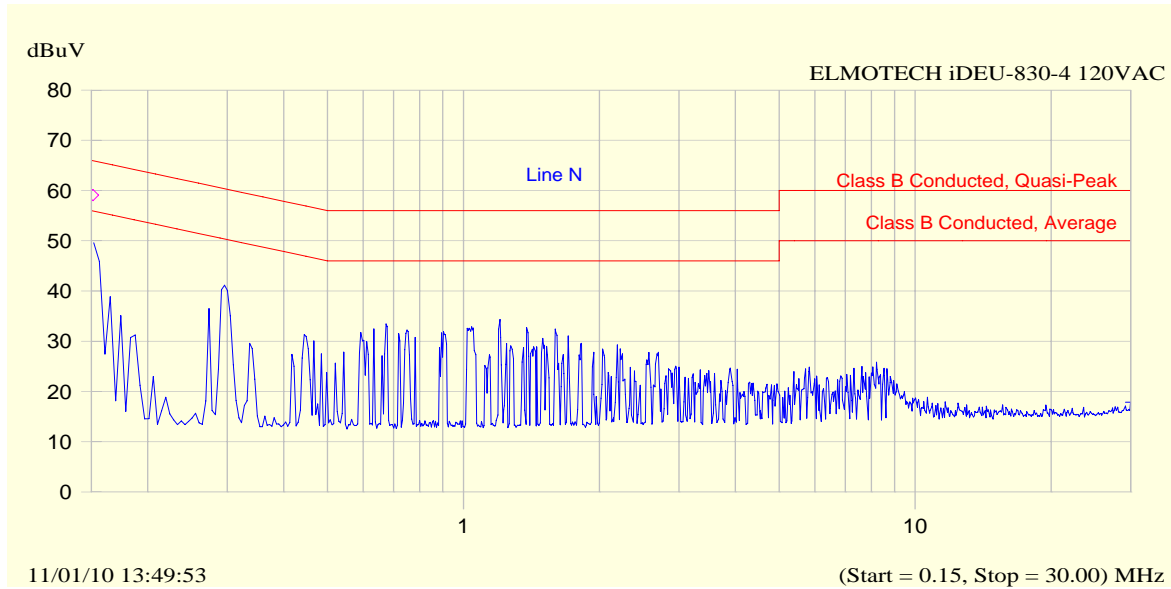

Frequency MHz	QP dB $\mu$ V	QP Limit dB $\mu$ V	Margin dB	Avg dB $\mu$ V	Avg Limit dB $\mu$ V	Margin dB
0.151	58.1	65.9	7.8	53.1	55.9	2.8
0.298	42.3	60.3	18.0	38.5	50.3	11.8
0.686	24.8	56.0	31.2	9.5	46.0	36.5
0.744	28.7	56.0	27.3	19.8	46.0	26.2
1.200	33.4	56.0	22.6	30.9	46.0	15.1
1.699	24.9	56.0	31.1	2.9	46.0	43.1

**Table 6. Conducted emission result. Line Neutral.**

**3.8.3. Test summary:**

The unit meets the standard requirement.

**Test Report No.:** 9012300934**Page 22 of 25 pages****Title:** Test on Repeater**FCC ID:** LSQ-IDEU-830-4**Model:** iDEU-830-4

#### 4. Appendix 1. Test equipment used

All measurements equipment is on SII calibration schedule with a recalibration interval not exceeding one year.

Instrument	MFR	Model	Serial No.	Due calibration date
EMI Receiver 9 kHz – 6.5 GHz	HP	8546A+85460A	SII 4068	April 2010
Biconilog Antenna 30 – 2000 MHz	Teseq GmbH	CBL 6112D	S/N 23181	Aug 2010
Active Loop antenna 10 kHz – 30 MHz	EMCO	6502	SII 4874	Oct 2010
EMI Analyser 9 kHz - 26.5 GHz	HP	E7405A	SII 4944	April 2010
Antenna Double Ridged Guide, 1-18 GHz	EMCO	3115	SII4873	Aug 2010
LISN 9 kHz – 30 MHz	FCC	LISN 250-32-4-16	SII 5023	Oct 2010
Transient limiter 0.009-200 MHz	HP	11947A	3107105	Oct 2010
Oscilloscope	HP	54610B	US37340682	May 2010
RF cable, 4m	SUNNER	Sucoflex 104PE	21329/4PE	Oct 2010
Antenna Mast	R&S	HCM	100002	N/A
Metallic turntable	R&S	HCT12	100001	N/A
Positioning controller	R&S	HCC	100002	N/A



**Test Report No.:** 9012300934**Page 23 of 25 pages****Title:** Test on Repeater**FCC ID:** LSQ-IDEU-830-4**Model:** iDEU-830-4

## 5. Appendix 2: Antenna Factor and Cable Loss

**Cable Loss (10m cable + Mast)**

Point	Frequency (MHz)	Cable Loss (dB)	Point	Frequency (MHz)	Cable Loss (dB)
1	30	0.53	21	1000	3.68
2	50	0.75	22	1100	3.82
3	100	1.08	23	1200	4.07
4	150	1.39	24	1300	4.24
5	200	1.61	25	1400	4.43
6	250	1.752	26	1500	4.6
7	300	2.00	27	1600	4.7
8	350	2.15	28	1700	4.85
9	400	2.26	29	1800	4.98
10	450	2.383	30	1900	5.19
11	500	2.52	31	2000	5.34
12	550	2.606	32	2100	5.51
13	600	2.75	33	2200	5.69
14	650	2.856	34	2300	5.89
15	700	3.06	35	2400	6.07
16	750	3.20	36	2500	6.22
17	800	3.27	37	2600	6.28
18	850	3.38	38	2700	6.41
19	900	3.46	39	2800	6.53
20	950	3.55	40	2900	6.84



**Test Report No.:** 9012300934

**Page** 24 of 25 pages

**Title:** Test on Repeater

**FCC ID:** LSQ-IDEU-830-4

**Model:** iDEU-830-4

**Table 7. Antenna Factor**

**For Bilog Antenna, Model Number: CBL 6112D, S/N: 23181**

No.	f / MHz)	AF / dB/m	f / MHz)	AF / dB/m	f / MHz)	AF / dB/m	f / MHz)	AF / dB/m
1	30	17.90	170	9.40	530	17.70	1040	22.20
2	32	16.70	175	9.00	540	18.25	1060	22.50
3	34	15.55	180	8.50	550	18.60	1080	22.50
4	36	14.35	185	8.45	560	14.45	1100	22.40
5	38	13.30	190	8.60	570	18.40	1120	22.60
6	40	12.20	195	8.85	580	18.50	1140	22.45
7	42	11.05	200	8.95	590	18.60	1160	22.50
8	44	9.95	205	8.80	600	18.60	1180	22.40
9	46	8.90	210	8.50	610	18.80	1200	22.80
10	48	8.05	215	8.20	620	18.99	1220	22.95
11	50	7.30	220	8.50	630	19.05	1240	23.10
12	52	6.80	225	9.00	640	19.23	1260	23.40
13	54	6.45	230	9.65	650	19.10	1280	23.35
14	56	6.00	235	10.30	660	19.13	1300	23.62
15	58	5.70	240	11.00	670	19.04	1320	23.64
16	60	5.45	245	11.60	680	19.00	1340	23.86
17	62	5.30	250	12.00	690	19.17	1360	23.95
18	64	5.20	255	12.45	700	19.28	1380	23.90
19	66	5.30	260	12.85	710	19.25	1400	24.45
20	68	5.30	265	12.50	720	19.45	1420	24.74
21	70	5.35	270	12.45	730	19.75	1440	24.93
22	72	5.50	275	12.40	740	19.95	1460	25.03
23	74	5.80	280	12.55	750	20.07	1480	25.45
24	76	6.00	285	12.65	760	19.85	1500	25.30
25	78	6.60	290	12.75	770	19.80	1520	25.25
26	80	6.70	295	12.95	780	19.85	1540	25.36
27	82	7.15	300	13.00	790	19.95	1560	25.58
28	84	7.60	310	13.35	800	20.05	1580	25.50
29	86	8.10	320	13.75	810	20.10	1600	25.65
30	88	8.50	330	13.85	820	20.35	1620	25.60
31	90	8.90	340	14.10	830	20.40	1640	25.70
32	92	9.20	350	14.50	840	20.35	1660	25.83
33	94	9.75	360	14.70	850	20.46	1680	25.97
34	96	9.95	370	14.90	860	20.39	1700	26.10
35	98	10.20	380	15.10	870	20.29	1720	26.25
36	100	10.50	390	15.45	880	20.24	1740	26.04
37	105	11.25	400	16.00	890	20.35	1760	26.14
38	110	11.70	410	16.40	900	20.55	1780	26.20
39	115	11.70	420	16.70	910	20.45	1800	26.40
40	120	11.80	430	16.35	920	20.60	1820	26.64
41	125	11.80	440	16.30	930	20.60	1840	26.86
42	130	11.70	450	16.30	940	20.66	1860	27.12
43	135	11.35	460	16.70	950	20.88	1880	27.00
44	140	10.95	470	17.05	960	21.11	1900	27.25
45	145	10.35	480	17.20	970	20.93	1920	27.36
46	150	10.05	490	17.30	980	21.03	1940	27.68
47	155	9.70	500	17.40	990	21.05	1960	27.10
48	160	9.70	510	17.50	1000	21.10	1980	27.06
49	165	9.45	520	17.60	1020	21.40	2000	27.25



**Test Report No.:** 9012300934

**Page** 25 of 25 pages

**Title:** Test on Repeater

**FCC ID:** LSQ-IDEU-830-4

**Model:** iDEU-830-4

**Antenna Factor**

**Double Ridged Guide Antenna mfr EMCO model 3115 1m calibration**

Point	Frequency (MHz)	Antenna Factor (dB/m)
1	1000	23.9
2	2000	28.3
3	3000	31.0
4	4000	33.1
5	4500	32.5
6	5000	32.4
7	6000	53.7
8	6500	35.6
9	7000	36.4
10	7500	36.9
11	8000	37.0
12	8500	38.0
13	9000	38.6
14	9500	38.4
15	10000	38.4
16	10500	38.4
17	11000	38.9
18	11500	39.6
19	12000	39.4
20	12500	39.2
21	13000	40.3
22	13500	41.0
23	14000	41.2
24	14500	41.3
25	15000	40.0
26	15500	38.0
27	16000	38.1
28	16500	40.3
29	17000	42.2
30	17500	44.6
31	18000	46.2

**Cable Loss**

**Type: Sucoflex 104PE; Ser.No.21329/4PE; 4 m length**

Point	Frequency (GHz)	Cable Loss (dB)
1	0.0-1.0	1.7
2	1.0- 3.5	3.2
3	3.5- 5.5	4.0
4	5.5 - 7.5	4.7
5	7.5 - 9.5	5.3
6	9.5 - 10.5	5.6
7	10.5 - 12.5	6.2
8	12.5 - 14.5	6.8
9	14.5 - 16.5	7.5
10	16.5 - 18.0	8.1