



Engineering Solutions & Electromagnetic Compatibility Services

**Certification Application Report for Full Modular Approval  
FCC Part 15.247 & Industry Canada RSS-247**

<b>Test Lab:</b> Rhein Tech Laboratories, Inc.      Tel: 703-689-0368 360 Herndon Parkway              Fax: 703-689-2056 Suite 1400                              www.rheintech.com Herndon, VA 20170 E-Mail: atcbinfo@rheintech.com		<b>Applicant:</b> Hunter Engineering Co.      Tel: 314-731-3020 11250 Hunter Drive              Fax: 314-731-9932 Bridgeton, MO 63044-2391 Contact: Jim McClenahan	
<b>FCC ID/IC</b>	LS3-45-1549/ 2938A-451549	<b>Test Report Date</b>	September 30, 2016
<b>Platform</b>	N/A	<b>RTL Work Order #</b>	2016038
<b>Model</b>	45-1549	<b>RTL Quote #</b>	QRTL16-138B
<b>American National Standard Institute</b>	ANSI C63.10-2013: American National Standard of Procedures for Compliance Testing of Unlicensed Wireless Devices		
<b>FCC Classification</b>	DTS – Part 15 Digital Transmission System		
<b>FCC Rule Part(s)/Guidance</b>	FCC Rules Part 15.247: Operation within the bands 920-928 MHz, 2400-2483.5 MHz and 5725-5850 MHz Direct Sequence System (2015)		
<b>Industry Canada</b>	RSS-247 Issue 1: Digital Transmission Systems (DTSs), Frequency Hopping Systems (FHSs) and Licence-Exempt Local Area Network (LE-LAN) Devices RSS-Gen Issue 4: General Requirements for Compliance of Radio Apparatus		
<b>Frequency Range (MHz)</b>	<b>Output Power (W)*</b>	<b>Frequency Tolerance</b>	<b>Emission Designator</b>
2405 – 2480	0.00008	N/A	1M58FXD

\* power is peak conducted

I, the undersigned, hereby declare that the equipment tested and referenced in this report conforms to the identified standard(s) as described in this test report. No modifications were made to the equipment during testing in order to achieve compliance with these standards. Furthermore, there was no deviation from, additions to, or exclusions from, the applicable parts of FCC Part 2, FCC Part 15, Industry Canada RSS-247, RSS-Gen, and ANSI C63.10.

Signature: 

Date: September 30, 2016

Typed/Printed Name: Desmond A. Fraser

Position: President

*This report may not be reproduced, except in full, without the written approval of Rhein Tech Laboratories, Inc. and Hunter Engineering Company. The test results relate only to the item(s) tested.*

*These test(s) are accredited under Rhein Tech Laboratories, Inc. ISO/IEC 17025 accreditation issued by ANAB. Refer to certificate and scope of accreditation AT-1445.*

## Table of Contents

---

1	General Information .....	5
1.1	Scope .....	5
1.2	Description of EUT .....	5
1.3	Test Facility .....	5
1.4	Related Submittal(s)/Grant(s) .....	5
1.5	Modifications .....	5
2	Test Information .....	6
2.1	Description of Test Modes .....	6
2.2	Exercising the EUT .....	6
2.3	Test Result Summary .....	6
2.4	Test System Details .....	7
2.5	Configuration of Tested System .....	7
3	Peak Output Power – FCC 15.247(b)(1); IC RSS-247 5.4(4), RSS-Gen 6.12 .....	8
3.1	Power Output Test Procedure .....	8
3.2	Power Output Test Data .....	8
4	Compliance with the Band Edge – FCC 15.247(d); RSS-247 5.5 .....	9
4.1	Band Edge Test Procedure .....	9
4.2	Band Edge Test Results .....	9
4.2.1	Calculation of Lower Band Edge .....	9
4.2.2	Lower Band Edge – Conducted Delta Plot .....	10
4.2.3	Calculation of Upper Band Edge .....	11
4.2.4	Upper Band Edge – Conducted Delta Plot .....	12
5	Antenna Conducted Spurious Emissions - FCC 15.247(d); RSS-247 5.5 .....	13
5.1	Antenna Conducted Spurious Emissions Test Procedures .....	13
5.2	Antenna Conducted Spurious Emissions Data .....	13
6	6 dB Bandwidth - 15.247(a)(2); RSS-247 5.2(1) .....	16
6.1	6 dB Bandwidth Test Procedure – Minimum 6 dB Bandwidth .....	16
6.2	6 dB Bandwidth Test Results .....	16
7	Power Spectral Density - 15.247(e); RSS-247 5.2(2) .....	20
7.1	Power Spectral Density Test Procedure .....	20
7.2	Power Spectral Density Test Data .....	20
8	Conducted Emissions Measurement Limits – FCC 15.207; RSS-Gen 8.8 .....	24
8.1	Limits of Conducted Emissions Measurement .....	24
8.2	Site and Test Description .....	24
8.3	Conducted Emissions Test Data .....	25
9	Radiated Emissions - FCC 15.209; RSS-247 2.2; RSS-Gen 6.13/7.1 .....	27
9.1	Limits of Radiated Emissions Measurement .....	27
9.2	Radiated Emissions Measurement Test Procedure .....	27
9.3	Radiated Emissions Test Results .....	29
9.3.1	Radiated Emissions Digital Test Data .....	29
9.3.2	Radiated Emissions Harmonics/Spurious Test Data .....	29
10	Conclusion .....	30

---

### Figure Index

---

Figure 2-1:	Configuration of System under Test.....	7
-------------	---	---

---

### Table Index

---

Table 2-1:	Channels Tested .....	6
Table 2-2:	Test Result Summary – FCC Part 15 Subpart C (Section 15.247); RSS-247 .....	6
Table 2-3:	Equipment under Test.....	7
Table 3-1:	Power Output Test Equipment .....	8
Table 3-2:	Power Output Test Data.....	8
Table 4-1:	Band Edge Test Equipment .....	9
Table 5-1:	Antenna Conducted Spurious Emissions Test Equipment .....	15
Table 6-1:	6 dB Bandwidth Test Equipment.....	16
Table 6-2:	6 dB Bandwidth Test Data .....	16
Table 7-1:	Power Spectral Density Test Equipment .....	20
Table 7-2:	Power Spectral Density Test Data .....	20
Table 8-1:	Conducted Emissions Test Equipment .....	24
Table 9-1:	Radiated Emissions Test Equipment .....	28
Table 9-2:	Digital Radiated Emissions Test Data.....	29
Table 9-3:	Radiated Emissions Harmonics/Spurious - 2405 MHz .....	29
Table 9-4:	Radiated Emissions Harmonics/Spurious - 2440 MHz .....	29
Table 9-5:	Radiated Emissions Harmonics/Spurious - 2480 MHz .....	30

---

### Plot Index

---

Plot 4-1:	Lower Band Edge.....	10
Plot 4-2:	Upper Band Edge.....	12
Plot 5-1:	Antenna Conducted Spurious Emissions – 2405 MHz .....	13
Plot 5-2:	Antenna Conducted Spurious Emissions – 2440 MHz .....	14
Plot 5-3:	Antenna Conducted Spurious Emissions – 2480 MHz .....	15
Plot 6-1:	6 dB Bandwidth – 2405 MHz.....	17
Plot 6-2:	6 dB Bandwidth – 2440 MHz.....	18
Plot 6-3:	6 dB Bandwidth – 2480 MHz.....	19
Plot 7-1:	Power Spectral Density – 2405 MHz .....	21
Plot 7-2:	Power Spectral Density – 2440 MHz .....	22
Plot 7-3:	Power Spectral Density – 2480 MHz .....	23
Plot 8-1:	Conducted Emissions Test Data – Neutral - TX Mode .....	25
Plot 8-2:	Conducted Emissions Test Data – Phase - TX Mode.....	26

---

### Appendix Index

---

Appendix A:	FCC Part 1.1307, 1.1310, 2.1091, 2.1093; IC RSS-Gen: RF Exposure.....	31
Appendix B:	Agency Authorization Letter .....	32
Appendix C:	FCC Modular Approval.....	33
Appendix D:	IC Agent Authority & IC Listing Requirement Letters.....	34
Appendix E:	IC Modular Construction .....	35
Appendix F:	Canadian Representative Attestation.....	36
Appendix G:	Label and Label Location .....	37
Appendix H:	Technical Operational Description .....	38
Appendix I:	Schematics.....	39
Appendix J:	Block Diagram.....	40
Appendix K:	Manual.....	41
Appendix L:	Test Photographs.....	42
Appendix M:	External Photographs.....	48
Appendix N:	Internal Photographs.....	51

---

### Photograph Index

---

Photograph 1:	ID Label & Location on EUT.....	37
Photograph 2:	Radiated Emissions Testing – Front View (< 1 GHz) .....	42
Photograph 3:	Radiated Emissions Testing – Back View (< 1 GHz).....	43
Photograph 4:	Radiated Emissions Testing – Front View (> 1 GHz) .....	44
Photograph 5:	Radiated Emissions Testing – Back View (> 1 GHz).....	45
Photograph 6:	Conducted Emissions Testing – Front View .....	46
Photograph 7:	Conducted Emissions Testing – Back View.....	47
Photograph 8:	Front with Shield.....	48
Photograph 9:	Front No Shield .....	49
Photograph 10:	Back View.....	50
Photograph 11:	Front with Shield.....	51
Photograph 12:	Front No Shield .....	52
Photograph 13:	Back View.....	53

## 1 General Information

### 1.1 Scope

This is an original FCC and Industry Canada modular approval certification application report.

Applicable Standards:

- FCC Rules Part 15.247: Frequency Hopping, Direct Spread Spectrum and Hybrid Systems that are in operation within the bands of 902-928 MHz, 2400-2483.5 MHz and 5725-5850 MHz
- Industry Canada RSS-247: Digital Transmission Systems (DTSs), Frequency Hopping Systems (FHSs) and Licence-Exempt Local Area Network (LE-LAN) Devices
- Industry Canada RSS-Gen: General Requirements for Compliance of Radio Apparatus

### 1.2 Description of EUT

<b>Equipment Under Test</b>	Transceiver
<b>Model</b>	45-1549
<b>Power Supply</b>	2 AA batteries (1.5V each)
<b>Modulation Type</b>	DSSS
<b>Frequency Range</b>	2405 – 2480 MHz
<b>Antenna Types</b>	PCB inverted F

### 1.3 Test Facility

The open area test site and conducted measurement facility used to collect the radiated data is located at 360 Herndon Parkway, Suite 1400, Herndon, Virginia 20170. This site has been fully described in a report and approved by the Federal Communications Commission to perform AC line conducted and radiated emissions testing.

### 1.4 Related Submittal(s)/Grant(s)

This is an original application for full modular approval for Hunter Engineering Company Model 45-1549, FCC ID: LS3-45-1549, IC: 2938A-451549.

### 1.5 Modifications

No modifications were made to the equipment during testing in order to achieve compliance with these standards.

## 2 Test Information

### 2.1 Description of Test Modes

In accordance with FCC 15.31(m), and because the EUT utilizes an operating band greater than 10 MHz, the following frequencies were tested:

**Table 2-1: Channels Tested**

Channel	Frequency
Low	2405
Middle	2440
High	2480

### 2.2 Exercising the EUT

The EUT was supplied with test firmware programmed with a high, mid, and low channel for testing. The EUT was tested in all three orthogonal planes in order to determine worst-case emissions. The EUT was provided with software to continuously transmit during testing. The carrier was also checked to verify that information was being transmitted. There were no deviations from the test standard(s) and/or methods. The test results reported relate only to the item tested.

### 2.3 Test Result Summary

**Table 2-2: Test Result Summary – FCC Part 15 Subpart C (Section 15.247); RSS-247**

FCC Standard	IC Standard	Test	Pass/Fail or N/A
15.247(b)(1)	RSS-247 5.4(4), RSS-Gen 6.12	Maximum Peak Power Output	Pass
15.247(d)	RSS-247 5.5	Band Edge Measurement	Pass
15.247(d)	RSS-247 5.5	Antenna Conducted Spurious Emissions	Pass
15.247(a)(2)	RSS-247 5.2(1)	6 dB Bandwidth	Pass
15.247(e)	RSS-247 5.2(2)	Power Spectral Density	Pass
15.207	RSS-Gen 8.8	AC Power Conducted Emissions	Pass
15.209	RSS-247 5.5, RSS-Gen 6.13/7.1	Radiated Emissions	Pass

## 2.4 Test System Details

The test samples were received on June 13 and September 27, 2016. The FCC identifiers for all applicable equipment, plus descriptions of all cables used in the tested system, are identified in the following table.

**Table 2-3: Equipment under Test**

Part	Manufacturer	Model	Serial Number	FCC ID	Cable Description	RTL Bar Code
Transceiver (Antenna Conducted)	Hunter Engineering Company	45-1549	31756BA	LS3-45-1549	N/A	22077
Transceiver	Hunter Engineering Company	45-1549	31751BA	LS3-45-1549	N/A	22078
Transceiver	Hunter Engineering Company	45-1549	19405FA	LS3-45-1549	N/A	22169
Test Controller	Hunter Engineering Company	N/A	N/A	N/A	N/A	17202

## 2.5 Configuration of Tested System

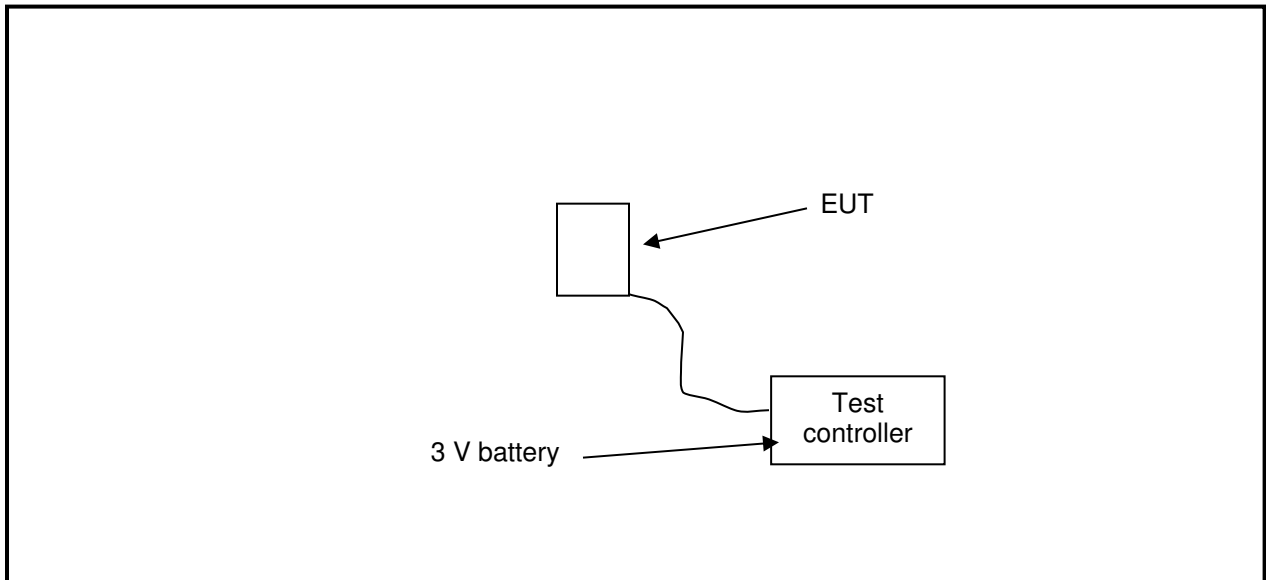

**Figure 2-1: Configuration of System under Test**

### 3 Peak Output Power – FCC 15.247(b)(1); IC RSS-247 5.4(4), RSS-Gen 6.12

#### 3.1 Power Output Test Procedure

A conducted antenna port power measurement of the EUT was taken per ANSI C63.10 11.9.1.1.

**Table 3-1: Power Output Test Equipment**

RTL Asset #	Manufacturer	Model	Part Type	Serial Number	Calibration Due Date
901581	Rohde & Schwarz	FSU	Spectrum Analyzer	1166.1660.50	3/22/18

#### 3.2 Power Output Test Data

**Table 3-2: Power Output Test Data**

Channel	Frequency (MHz)	Peak Power Conducted Output (dBm)
Low	2405	-11.4
Middle	2440	-11.2
High	2480	-11.0

#### Test Personnel:

Dan Baltzell  
Test Engineer



Signature

September 28, 2016  
Date of Test



#### 4 Compliance with the Band Edge – FCC 15.247(d); RSS-247 5.5

##### 4.1 Band Edge Test Procedure

The transmitter output was connected to its appropriate antenna. A conducted antenna port delta measurement was performed from the highest peak within 2 MHz within the restricted band to the peak of the fundamental, and subtracted from the radiated field strength; the result was compared to the limit per ANSI C63.10 11.13.

**Table 4-1: Band Edge Test Equipment**

RTL Asset #	Manufacturer	Model	Part Type	Serial Number	Calibration Due Date
900772	EMCO	3161-02	Horn Antenna (2 - 4 GHz)	9804-1044	4/9/18
900878	Rhein Tech Laboratories	AM3-1197-0005	3 meter Antenna Mast, polarizing	Outdoor Range 1	Not Required
900932	Hewlett Packard	8449B OPT H02	Preamplifier (1 - 26.5 GHz)	3008A00505	9/16/17
901242	Rhein Tech Laboratories	WRT-000-0003	Wood Rotating Table	N/A	Not Required
901583	Agilent Technologies	N9010A	EXA Signal Analyzer (10 Hz - 26.5 GHz)	MY51250846	4/21/17
901334	RF Depot	30-ft SMA	Cable	N/A	9/29/17
901668	RF Depot	3-ft	SMA Cable	N/A	10/26/16

##### 4.2 Band Edge Test Results

###### 4.2.1 Calculation of Lower Band Edge

84.9 dB $\mu$ V/m is the field strength measurement, from which the delta measurement of 50.4 dB is subtracted, resulting in a level of 34.5 dB. This level has a margin of 19.5 dB below the limit of 54.0 dB $\mu$ V/m.

Calculation: 84.9 dB $\mu$ V/m – 50.4 – 54.0 dB $\mu$ V/m = -19.5 dB

Peak Field Strength of Lower Band Edge (1 MHz RBW/3 MHz VBW) = 85.7 dB $\mu$ V/m  
 Average Field Strength of Lower Band Edge (1 MHz RBW/3 MHz VBW) = 84.9 dB $\mu$ V/m  
 Delta Measurement = 50.4 dB

### 4.2.2 Lower Band Edge – Conducted Delta Plot

Plot 4-1: Lower Band Edge



Rhein Tech Laboratories, Inc.  
360 Herndon Parkway  
Suite 1400  
Herndon, VA 20170  
<http://www.rheintech.com>

Client: Hunter Engineering Co.  
Model/HVIN: 45-1549  
Standards: FCC 15.247  
IDs: LS3-45-1549/2938A-451549  
Report #: 2016038DXT

#### **4.2.3 Calculation of Upper Band Edge**

88.7 dB $\mu$ V/m is the field strength measurement, from which the delta measurement of 37.4 dB is subtracted, resulting in a level of 51.3 dB. This level has a margin of 2.7 dB below the limit of 54.0 dB $\mu$ V/m.

Calculation:  $88.7 \text{ dB}\mu\text{V/m} - 37.4 - 54.0 \text{ dB}\mu\text{V/m} = -2.7 \text{ dB}$

Peak Field Strength of Lower Band Edge (1 MHz RBW/3 MHz VBW) = 89.2 dB $\mu$ V/m  
Average Field Strength of Lower Band Edge (1 MHz RBW/3 MHz VBW) = 88.7 dB $\mu$ V/m  
Delta measurement = 37.4 dB

#### 4.2.4 Upper Band Edge – Conducted Delta Plot

Plot 4-2: Upper Band Edge

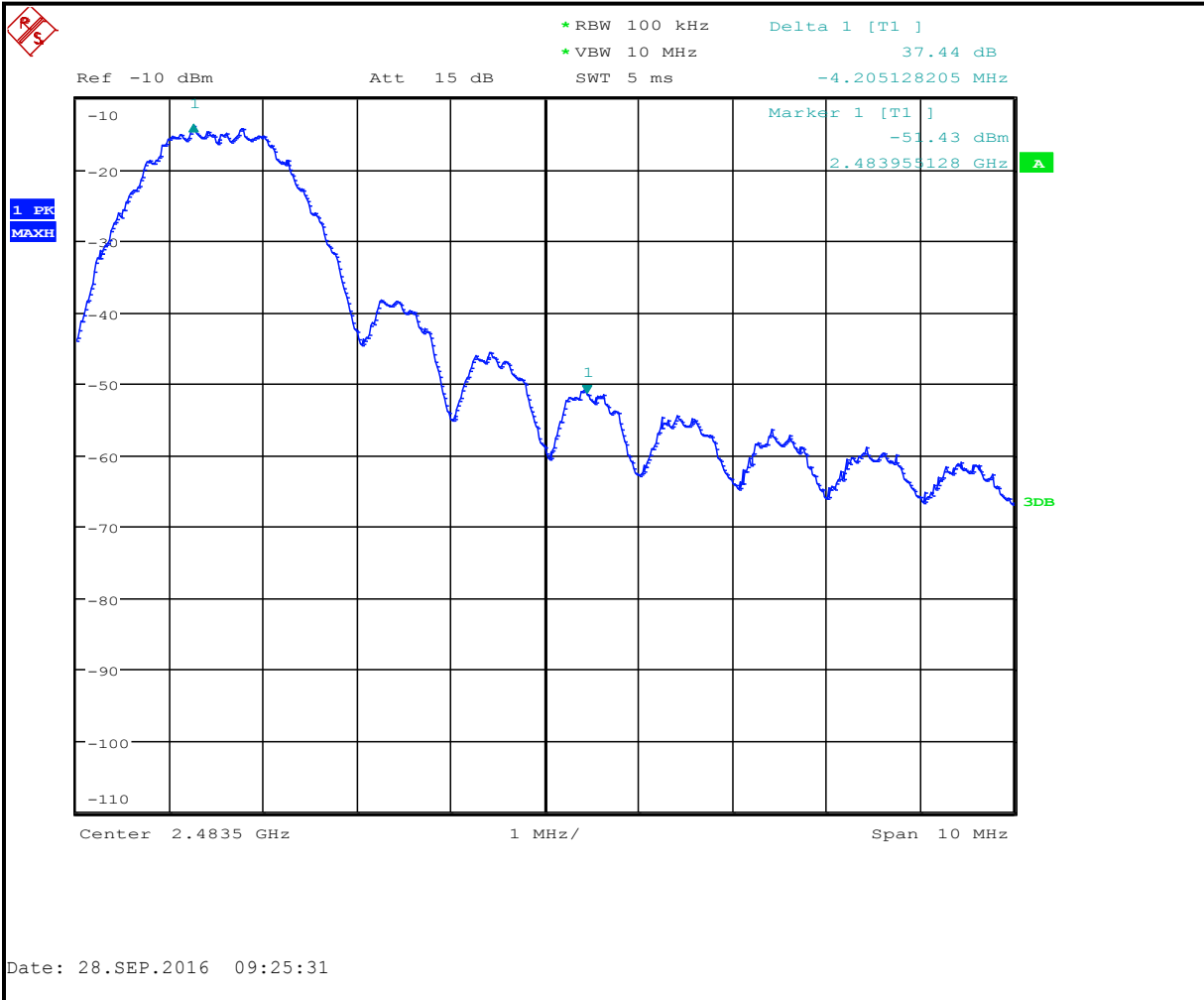

#### Test Personnel:

Dan Baltzell  
Test Engineer

Signature

September 28, 2016  
Date of Test

## 5 Antenna Conducted Spurious Emissions - FCC 15.247(d); RSS-247 5.5

### 5.1 Antenna Conducted Spurious Emissions Test Procedures

Antenna spurious emissions per FCC 15.247(d) and C63.10-2013 6.7 were measured from the EUT antenna port using a 50 ohm spectrum analyzer. The modulated carrier was identified at the following frequencies: 2405 MHz, 2440 MHz and 2480 MHz.

### 5.2 Antenna Conducted Spurious Emissions Data

Plot 5-1: Antenna Conducted Spurious Emissions – 2405 MHz

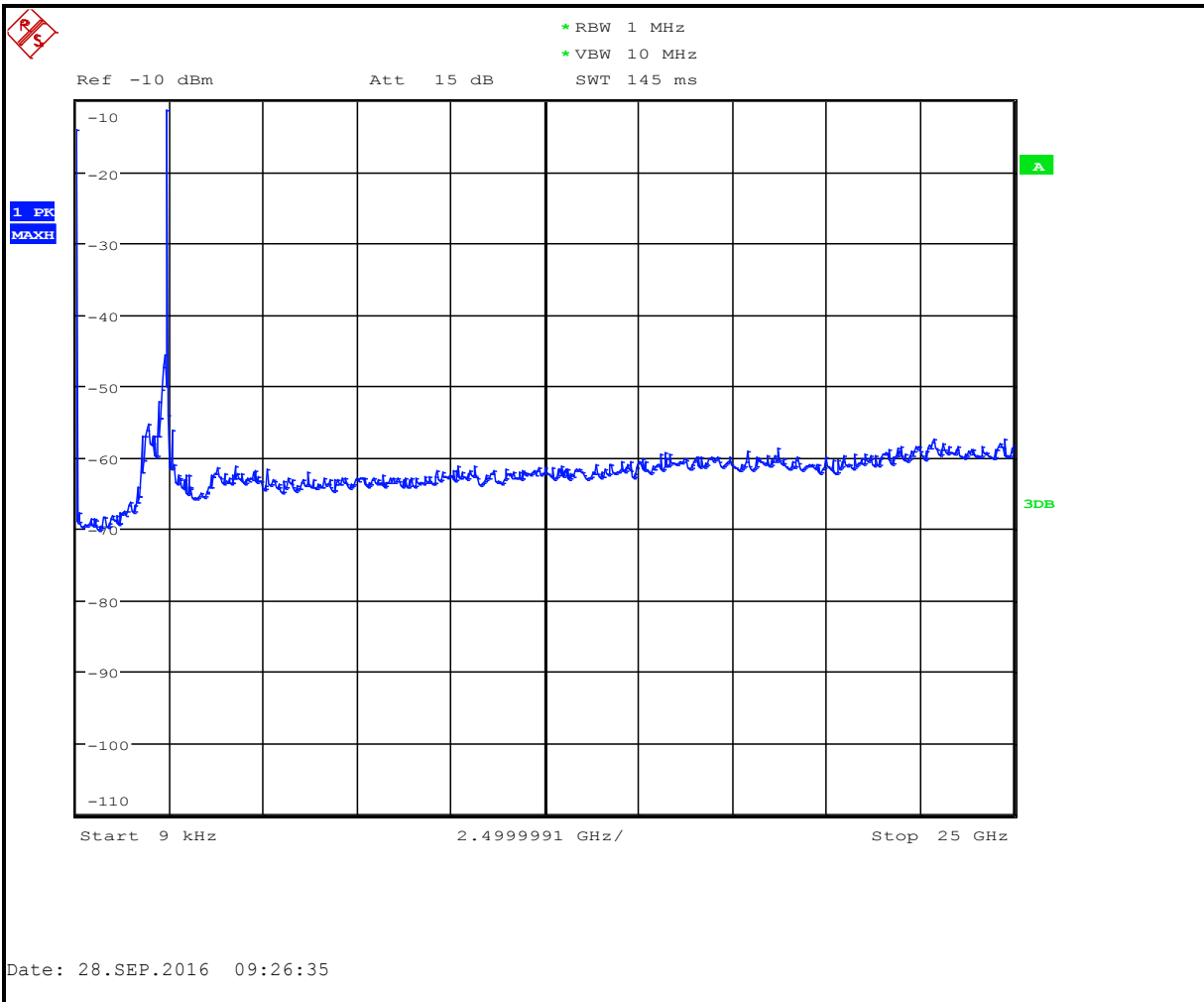

**Plot 5-2: Antenna Conducted Spurious Emissions – 2440 MHz**

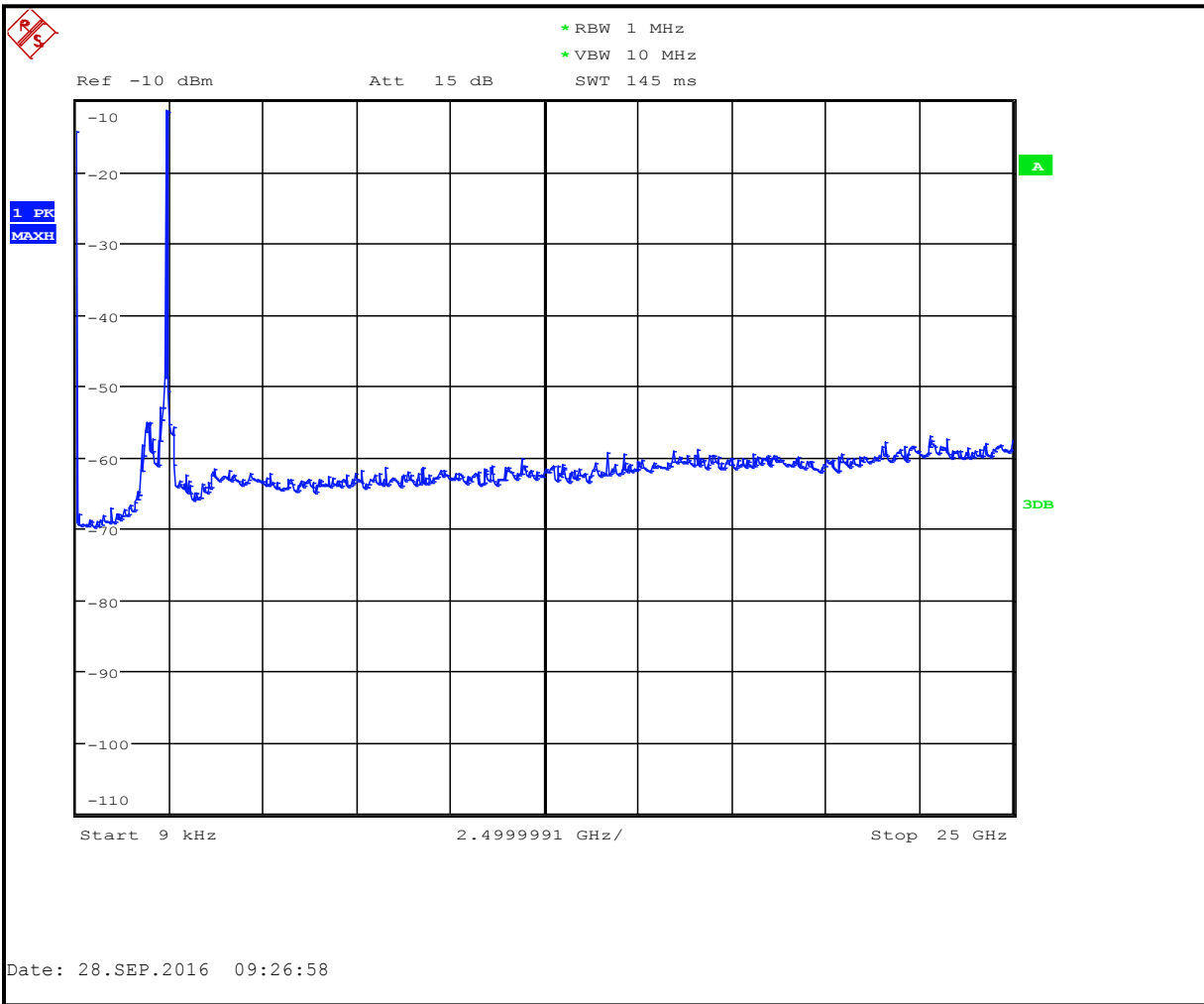



**6 6 dB Bandwidth - 15.247(a)(2); RSS-247 5.2(1)**

**6.1 6 dB Bandwidth Test Procedure – Minimum 6 dB Bandwidth**

The minimum 6 dB bandwidths per FCC 15.247(a)(2) were measured per ANSI C63.10 11.8 using a 50 ohm spectrum analyzer with the resolution bandwidth set at 100 kHz, and the video bandwidth set at 300 kHz. The device was modulated. The minimum 6 dB bandwidths are presented below.

**Table 6-1: 6 dB Bandwidth Test Equipment**

RTL Asset #	Manufacturer	Model	Part Type	Serial Number	Calibration Due Date
901581	Rohde & Schwarz	FSU	Spectrum Analyzer	1166.1660.50	3/22/18

**6.2 6 dB Bandwidth Test Results**

**Table 6-2: 6 dB Bandwidth Test Data**

Frequency (MHz)	6 dB Bandwidth (MHz)	Minimum Limit (MHz)	Pass/Fail
2405	1.55	0.5	Pass
2440	1.56	0.5	Pass
2480	1.58	0.5	Pass



**Plot 6-1: 6 dB Bandwidth – 2405 MHz**

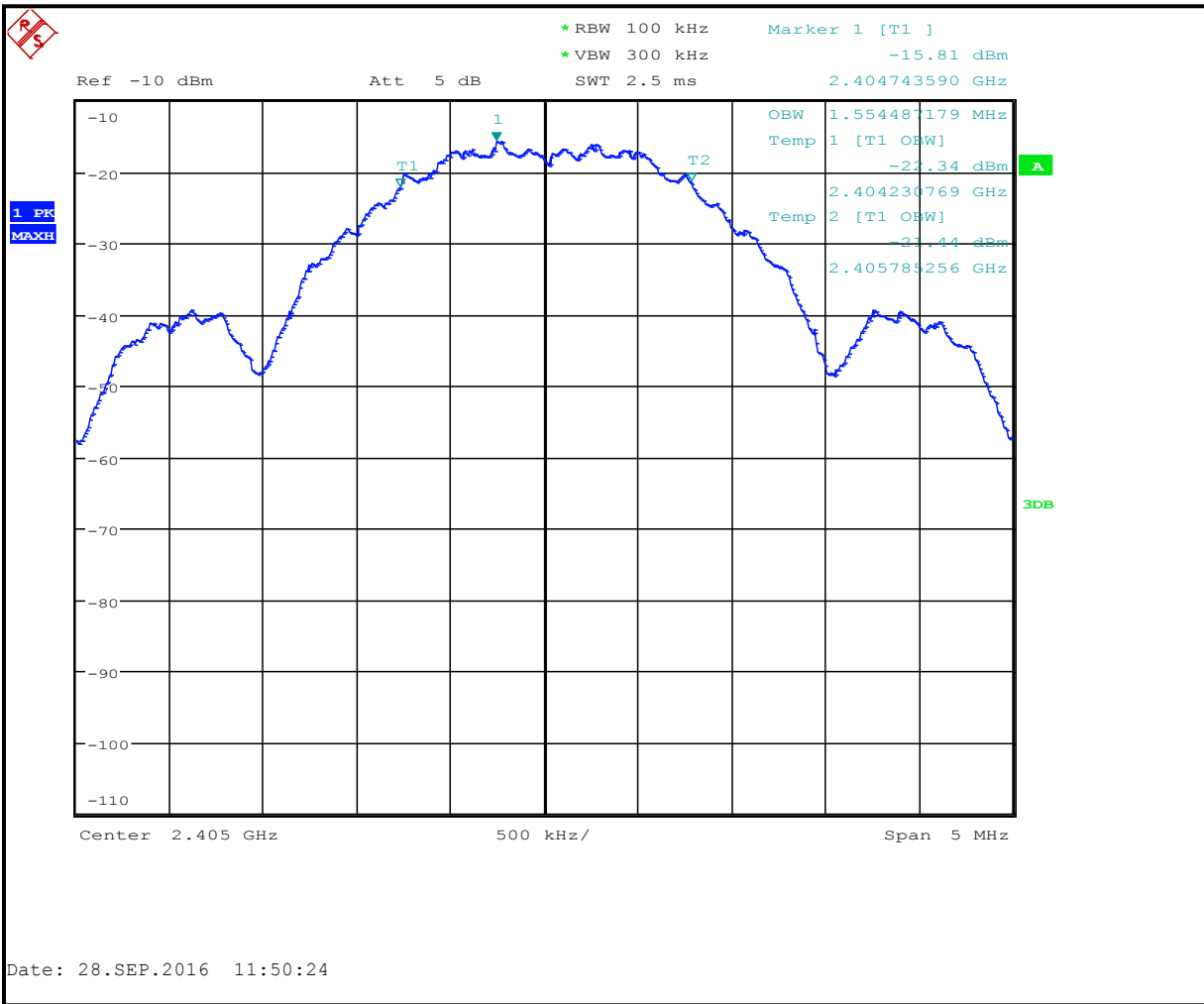

**Plot 6-2: 6 dB Bandwidth – 2440 MHz**

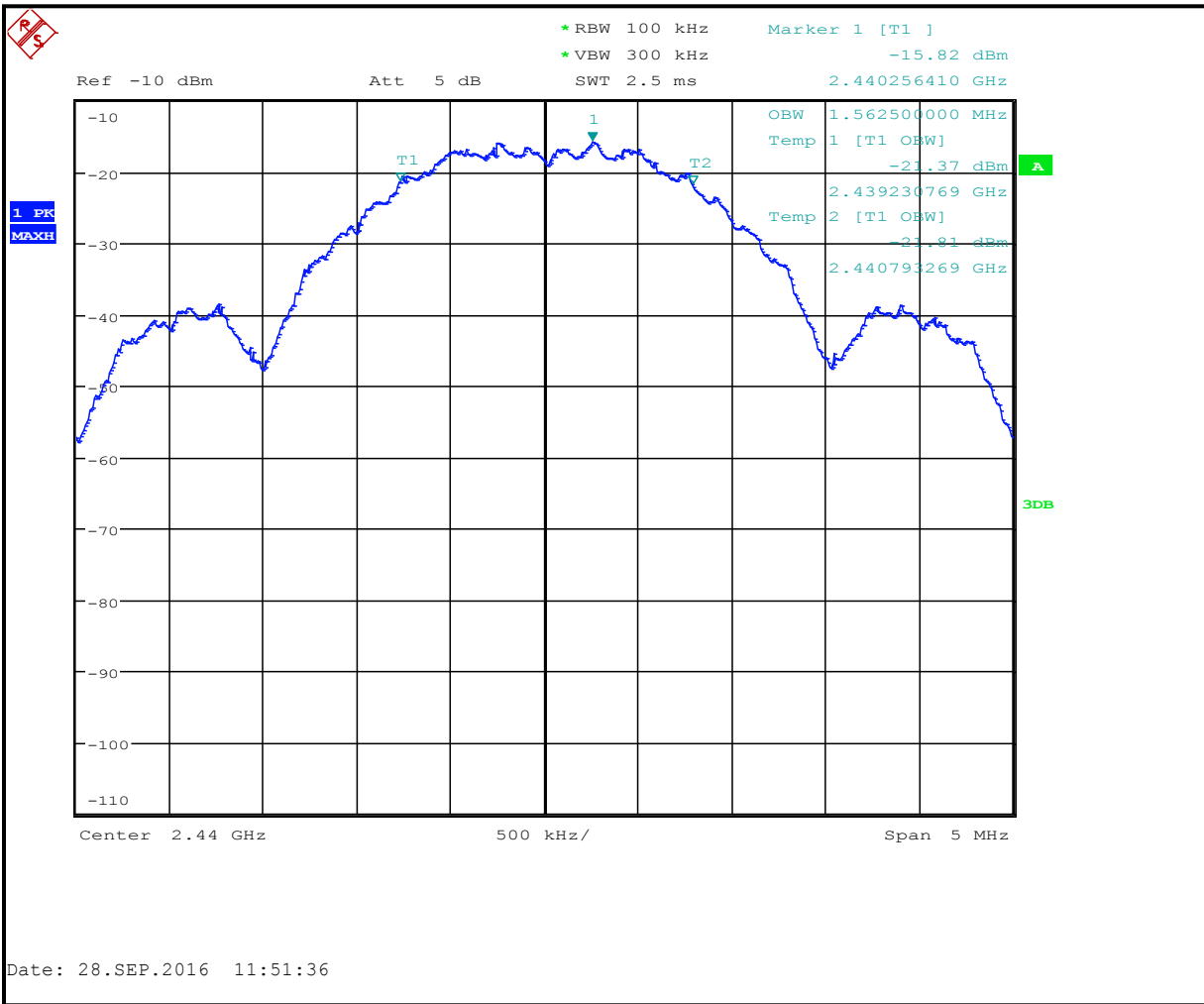

**Plot 6-3: 6 dB Bandwidth – 2480 MHz**

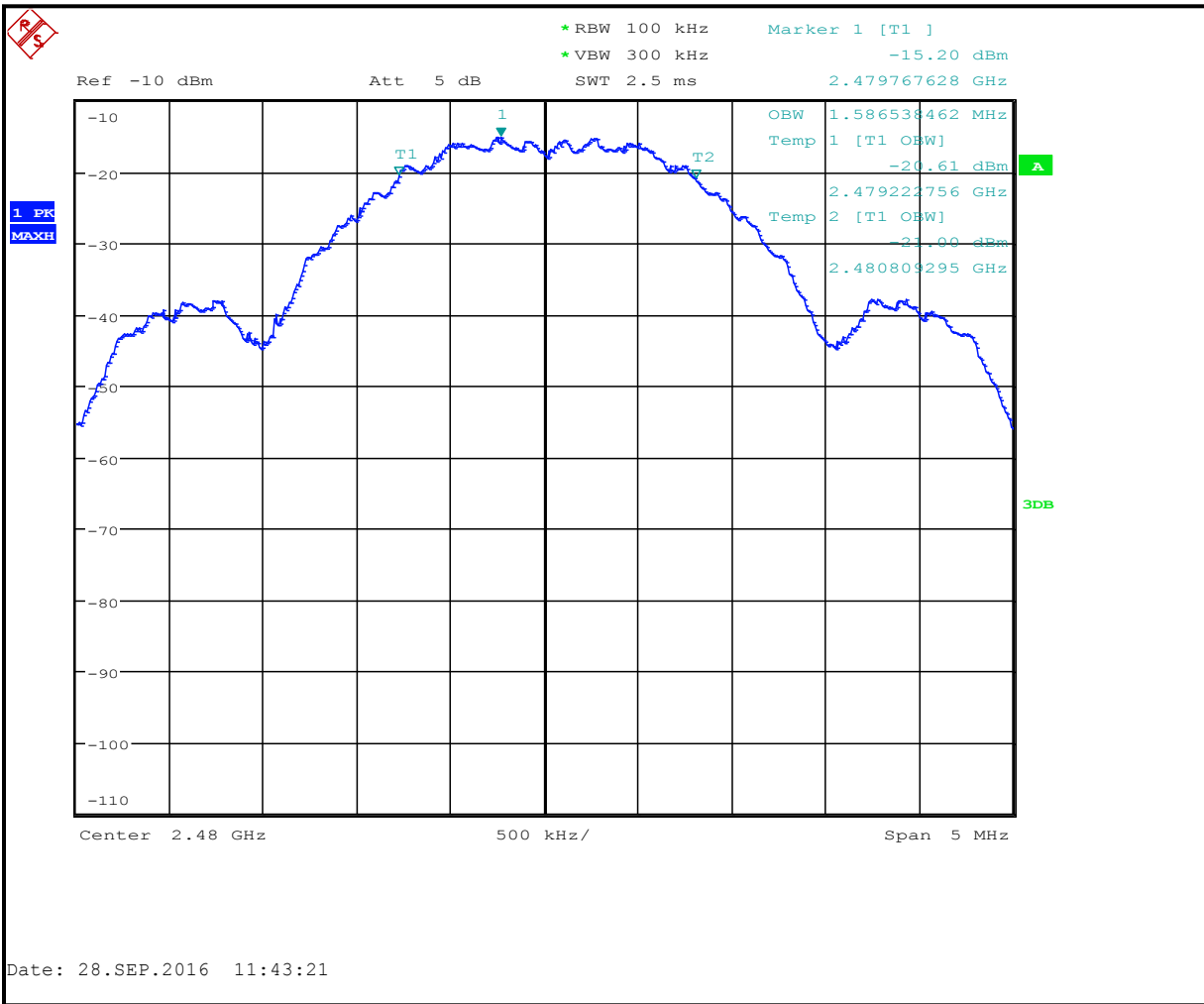

**Test Personnel:**

Dan Baltzell  
 Test Engineer

Signature

September 28, 2016  
 Date of Test

## 7 Power Spectral Density - 15.247(e); RSS-247 5.2(2)

### 7.1 Power Spectral Density Test Procedure

The power spectral density per FCC 15.247(e), and ANSI C63.10 11.10.2, was measured using a 50 ohm spectrum analyzer with the resolution bandwidth set at 3 kHz, the video bandwidth set at 30 kHz, and auto sweep time, using peak detector in max hold. The power spectral densities are presented for the modulated carriers at 2405, 2440 and 2480 MHz. These levels are below the +8 dBm limit. See the power spectral density table and plots.

**Table 7-1: Power Spectral Density Test Equipment**

RTL Asset #	Manufacturer	Model	Part Type	Serial Number	Calibration Due Date
901581	Rohde & Schwarz	FSU	Spectrum Analyzer	1166.1660.50	3/22/18

### 7.2 Power Spectral Density Test Data

**Table 7-2: Power Spectral Density Test Data**

Frequency (MHz)	RF Power Level (dBm)	Maximum Limit +8dBm	Pass/Fail
2405	-28.1	8	Pass
2440	-27.4	8	Pass
2480	-27.7	8	Pass

**Plot 7-1: Power Spectral Density – 2405 MHz**

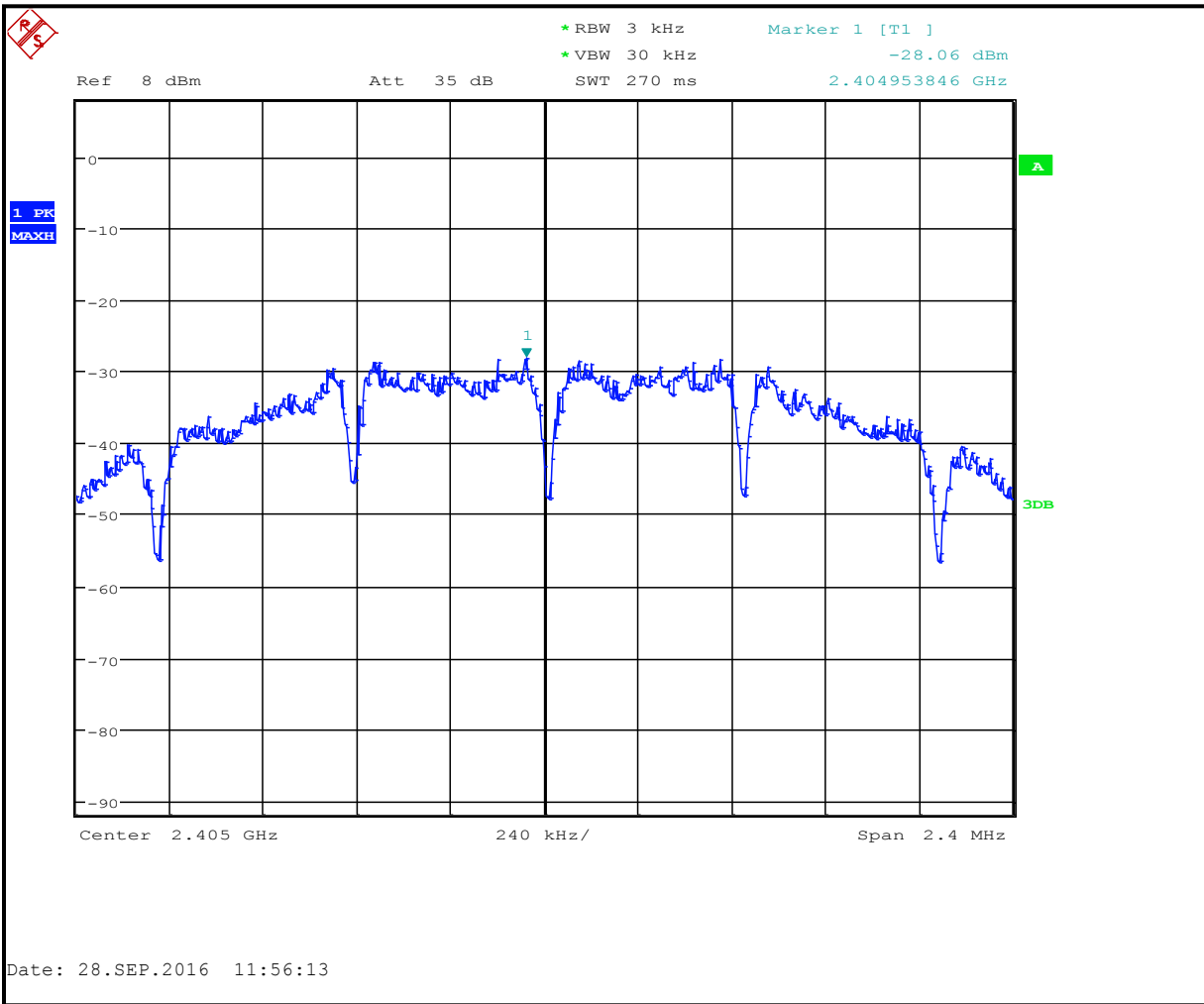

**Plot 7-2: Power Spectral Density – 2440 MHz**



**Plot 7-3: Power Spectral Density – 2480 MHz**

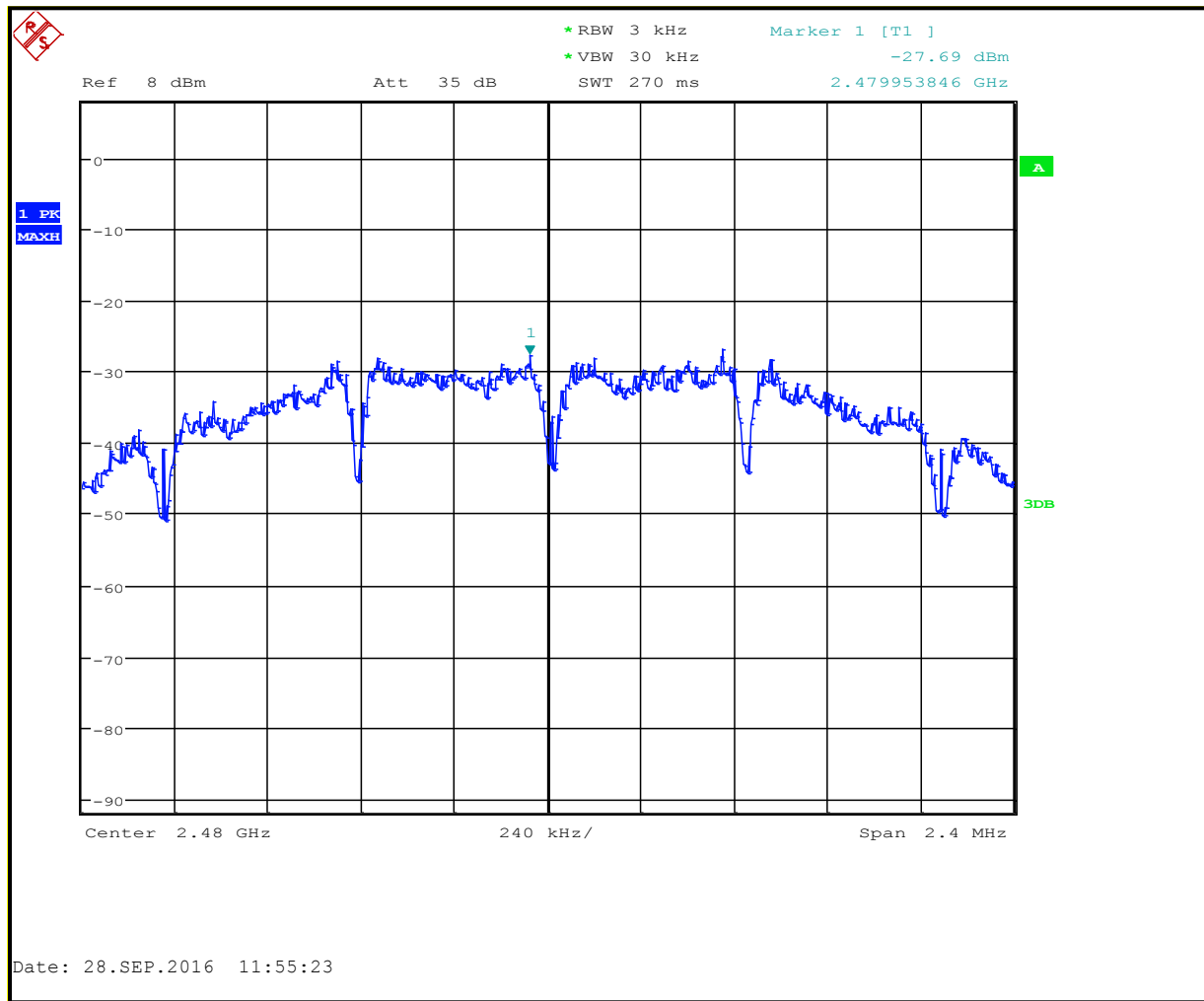

**Test Personnel:**

Dan Baltzell  
Test Engineer

Signature

September 28, 2016  
Date of Test

## 8 Conducted Emissions Measurement Limits – FCC 15.207; RSS-Gen 8.8

### 8.1 Limits of Conducted Emissions Measurement

Frequency of Emission (MHz)	Conducted Limit (dBuV)	
	Quasi-peak	Average
0.15-0.5	66-56	56-46
0.5-5.0	56	46
5.0-30.0	60	50

### 8.2 Site and Test Description

The power line conducted emissions measurements were performed in a Series 81 type shielded enclosure manufactured by Rayproof. The EUT was assembled on a wooden table 80 centimeters high. DC power was fed to the EUT with an off the shelf power supply, powered through a 50 ohm/50 microhenry Line Impedance Stabilization Network (LISN). The EUT LISN was fed power through an A.C. filter box on the outside of the shielded enclosure. The filter box and EUT LISN housing are bonded to the ground plane of the shielded enclosure. A second LISN, the peripheral LISN, provides isolation for the EUT test peripherals. This peripheral LISN was also fed A.C. power. A metal power outlet box, which is bonded to the ground plane and electrically connected to the peripheral LISN, powers the EUT host peripherals.

The spectrum analyzer was connected to the A.C. line through an isolation transformer. The 50 ohm output of the EUT LISN was connected to the spectrum analyzer input through a Solar 100 kHz high-pass filter. The filter is used to prevent overload of the spectrum analyzer from noise below 100 kHz. Conducted emission levels were measured on each current-carrying line with the spectrum analyzer operating in the CISPR quasi-peak mode (or peak mode if applicable).

The analyzer's 6 dB bandwidth was set to 9 kHz. Video filter less than 10 times the resolution bandwidth is not used. Average measurements are performed in linear mode using a 10 kHz resolution bandwidth, a 1 Hz video bandwidth, and by adjusting the sweep time in order to obtain a calibrated measurement. The emission spectrum was scanned from 150 kHz to 30 MHz. The highest emission amplitudes relative to the appropriate limits were measured and have been recorded.

**Table 8-1: Conducted Emissions Test Equipment**

RTL Asset #	Manufacturer	Model	Part Type	Serial Number	Calibration Due Date
901581	Rohde & Schwarz	FSU	Spectrum Analyzer	1166.1660.50	3/22/18
901084	AFJ International	LS16	16A LISN	16010020082	3/24/17
901699	Hewlett Packard	E3610A	Power Supply	KR72917306	Not Required



### 8.3 Conducted Emissions Test Data

Plot 8-1: Conducted Emissions Test Data – Neutral - TX Mode

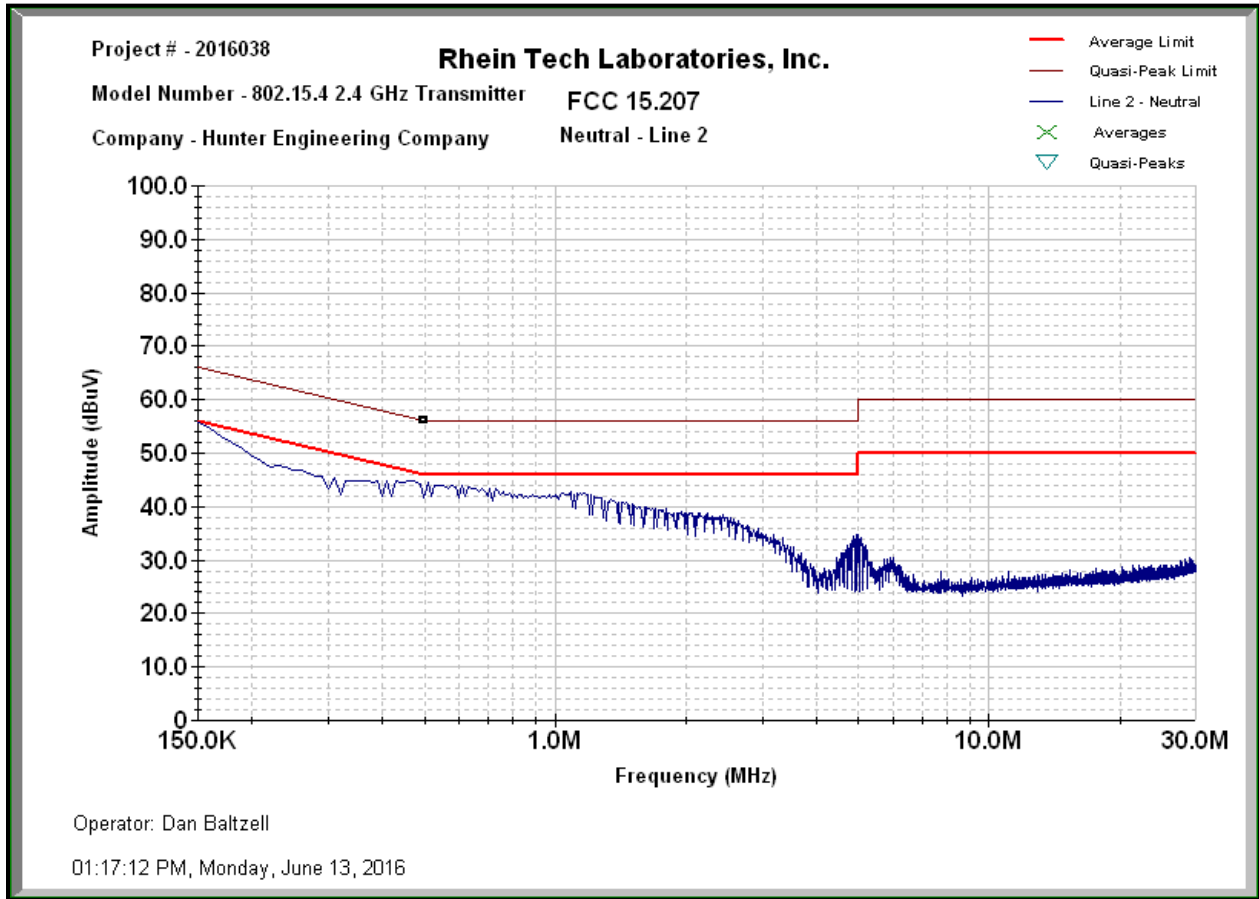

**Plot 8-2: Conducted Emissions Test Data – Phase - TX Mode**

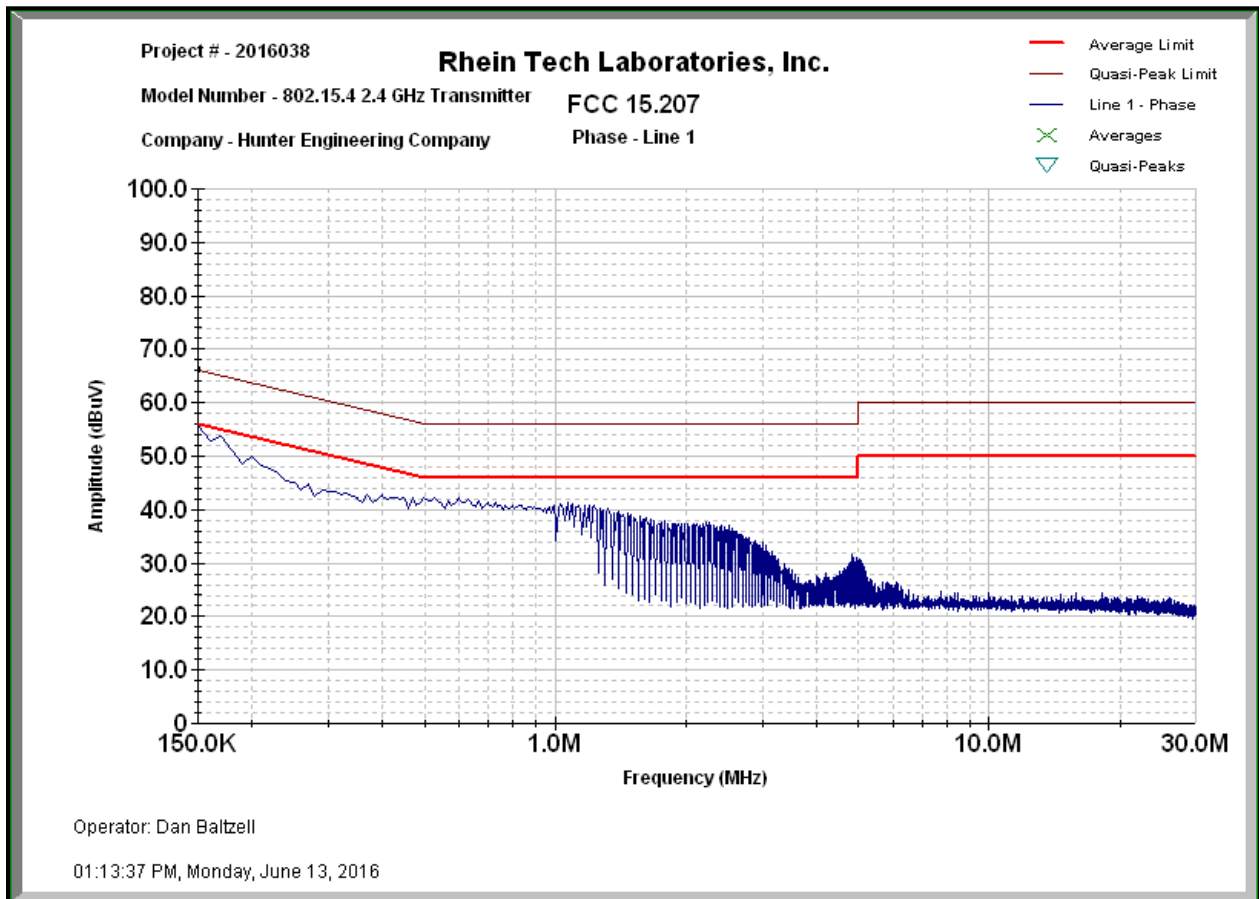

**Test Personnel:**

Dan Baltzell Test Engineer	 Signature	June 13, 2016 Date of Test
-------------------------------	--	-------------------------------

## 9 Radiated Emissions - FCC 15.209; RSS-247 2.2; RSS-Gen 6.13/7.1

### 9.1 Limits of Radiated Emissions Measurement

Frequency (MHz)	Field Strength (uV/m)	Measurement Distance (m)
0.009-0.490	2400/f (kHz)	300
0.490-1.705	2400/f (kHz)	30
1.705-30.0	30	30
30-88	100	3
88-216	150	3
216-960	200	3
Above 960	500	3

As shown in 15.35(b), for frequencies above 1000 MHz, the field strength limits are based on average detector, however, the peak field strength of any emission shall not exceed the maximum permitted average limits, specified above by more than 20 dB under any circumstances of modulation.

### 9.2 Radiated Emissions Measurement Test Procedure

Before final measurements of radiated emissions were made on the open-field three/ten meter range, the EUT was scanned indoors at one and three meter distances. This was done in order to determine its emissions spectrum signature. The physical arrangement of the test system and associated cabling was varied in order to determine the effect on the EUT's emissions in amplitude, direction and frequency. This process was repeated during final radiated emissions measurements on the open-field range, at each frequency, in order to ensure that maximum emission amplitudes were attained.

Final radiated emissions measurements were made on the three/ten-meter, open-field test site. The EUT was placed on a nonconductive turntable 0.8 meters above the ground plane for emissions less than 1 GHz, for emissions greater than 1 GHz the EUT was placed on a nonconductive turntable 1.5 m high. The spectrum was examined from 9 kHz to the 10<sup>th</sup> harmonic of the highest fundamental transmitter frequency (24.8 GHz).

At each frequency, the EUT was rotated 360°, and the antenna was raised and lowered from 1 to 4 meters in order to determine the emission's maximum level. Measurements were taken using both horizontal and vertical antenna polarizations. For frequencies between 30 and 1000 MHz, the spectrum analyzer's 6 dB bandwidth was set to 120 kHz, and the analyzer was operated in the CISPR quasi-peak detection mode. For emissions above 1000 MHz, emissions are measured using the average detector function with a minimum resolution bandwidth of 1 MHz. No video filter less than 10 times the resolution bandwidth was used. The highest emission amplitudes relative to the appropriate limit were measured and recorded in this report.

**Table 9-1: Radiated Emissions Test Equipment**

RTL Asset #	Manufacturer	Model	Part Type	Serial Number	Calibration Due Date
900151	Rohde and Schwarz	HFH2-Z2	Loop Antenna (9 kHz - 30 MHz)	827525/019	3/4/17
900905	Rhein Tech Labs	PR-1040	OATS 1 Preamplifier 40dB (30 MHz – 2 GHz)	1006	9/16/17
900878	Rhein Tech Laboratories	AM3-1197-0005	3 meter antenna mast, polarizing	Outdoor Range 1	Not Required
901592	Insulated Wire Inc.	KPS-1503-3600-KPR	SMK RF Cables 20'	NA	8/3/17
901242	Rhein Tech Laboratories	WRT-000-0003	Wood rotating table	N/A	Not Required
900913	Hewlett Packard	85462A	EMI Receiver RF Section (9 kHz – 6.5 GHz)	3325A00159	12/9/16
900914	Hewlett Packard	85460A	RF Filter Section (100 kHz - 6.5 GHz)	3330A00107	12/9/16
900772	EMCO	3161-02	Horn Antenna (2 - 4 GHz)	9804-1044	4/9/18
900321	EMCO	3161-03	Horn Antenna (4.0 - 8.2 GHz)	9508-1020	4/9/18
900323	EMCO	3160-07	Horn Antenna (8.2 - 12.4 GHz)	9605-1054	4/9/18
900356	EMCO	3160-08	Horn Antenna (12.4 - 18 GHz)	9607-1044	4/9/18
901218	EMCO	3160-09	Horn Antenna (18 - 26.5 GHz)	960281-003	4/14/18
901581	Rohde & Schwarz	FSU	Spectrum Analyzer	1166.1660.50	3/22/18

### 9.3 Radiated Emissions Test Results

#### 9.3.1 Radiated Emissions Digital Test Data

**Table 9-2: Digital Radiated Emissions Test Data**

Temperature: 74°F Humidity: 41%										
Emission Frequency (MHz)	Test Detector	Antenna Polarity (H/V)	Turntable Azimuth (deg)	Antenna Height (m)	Analyzer Reading (dBuV)	Site Correction Factor (dB/m)	Emission Level (dBuV/m)	Limit (dBuV/m)	Margin (dB)	Pass/Fail
42.430	Qp	V	0	1.0	49.8	-19.2	30.6	40.0	-9.4	Pass
89.678	Qp	V	0	1.0	44.5	-22.1	22.4	43.5	-21.1	Pass
116.018	Qp	V	0	1.0	37.0	-19.4	17.6	43.5	-25.9	Pass
792.199	Qp	V	0	1.0	31.3	-5.4	25.9	46.0	-20.1	Pass
1797.710	Av	H	0	1.0	33.3	7.5	40.8	54.0	-13.2	Pass
1915.048	Av	H	0	1.0	31.2	9.0	40.2	54.0	-13.8	Pass

#### 9.3.2 Radiated Emissions Harmonics/Spurious Test Data

**Table 9-3: Radiated Emissions Harmonics/Spurious - 2405 MHz**

Emission Frequency (MHz)	Peak Analyzer Reading (dBuV) (1 MHz RBW/VBW)	Average Analyzer Reading (dBuV)	Site Correction Factor (dB/m)	Average Emission Level (dBuV/m)	Average Limit (dBuV/m)	Average Margin (dB)
4810.0	56.0	54.5	-0.7	53.8	54.0	-0.2
12025.0	33.4	27.8	9.7	37.5	54.0	-16.5
19240.0	35.2	27.9	22.3	50.2	54.0	-3.8

**Table 9-4: Radiated Emissions Harmonics/Spurious - 2440 MHz**

Emission Frequency (MHz)	Peak Analyzer Reading (dBuV) (1 MHz RBW/VBW)	Average Analyzer Reading (dBuV)	Site Correction Factor (dB/m)	Average Emission Level (dBuV/m)	Average Limit (dBuV/m)	Average Margin (dB)
4880.0	56.4	54.5	-1.0	53.5	54.0	-0.5
7320.0	41.1	33.0	1.0	34.0	54.0	-20.0
12200.0	33.5	27.6	10.7	38.3	54.0	-15.7
19520.0	35.1	28.0	21.2	49.2	54.0	-4.8

**Table 9-5: Radiated Emissions Harmonics/Spurious - 2480 MHz**

Emission Frequency (MHz)	Peak Analyzer Reading (dBuV) (1 MHz RBW/VBW)	Average Analyzer Reading (dBuV)	Site Correction Factor (dB/m)	Average Emission Level (dBuV/m)	Average Limit (dBuV/m)	Average Margin (dB)
4960.0	56.2	54.6	-1.1	53.5	54.0	-0.5
7440.0	45.6	39.0	1.3	40.3	54.0	-13.7
12400.0	35.0	29.0	10.2	39.2	54.0	-14.8
19840.0	35.2	28.3	22.0	50.3	54.0	-3.7
22320.0	35.2	28.3	21.8	50.1	54.0	-3.9

**Test Personnel:**

		
Dan Baltzell	Signature	June 13 & September 27, 2016
Test Engineer		Dates of Test

**10 Conclusion**

The data in this measurement report shows that the EUT as tested, Hunter Engineering Company, Model 45-1549, FCC ID: LS3-45-1549, IC: 2938A-451549, complies with all the applicable requirements of Parts 2 and 15 of the FCC Rules and Regulations and Industry Canada RSS-247.