

Appendix H: Label and Label Location

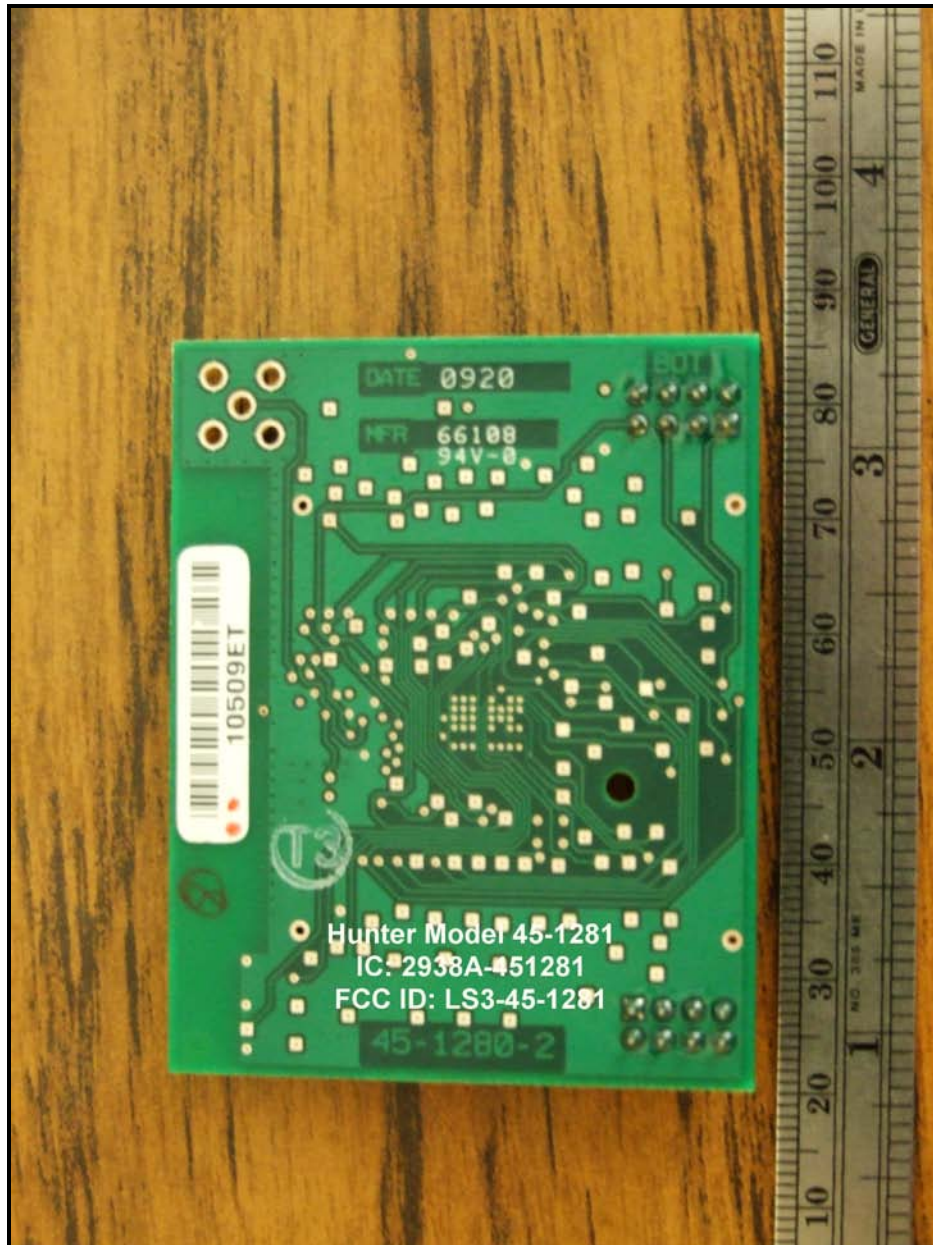

Photograph 1: ID Label & Location on EUT

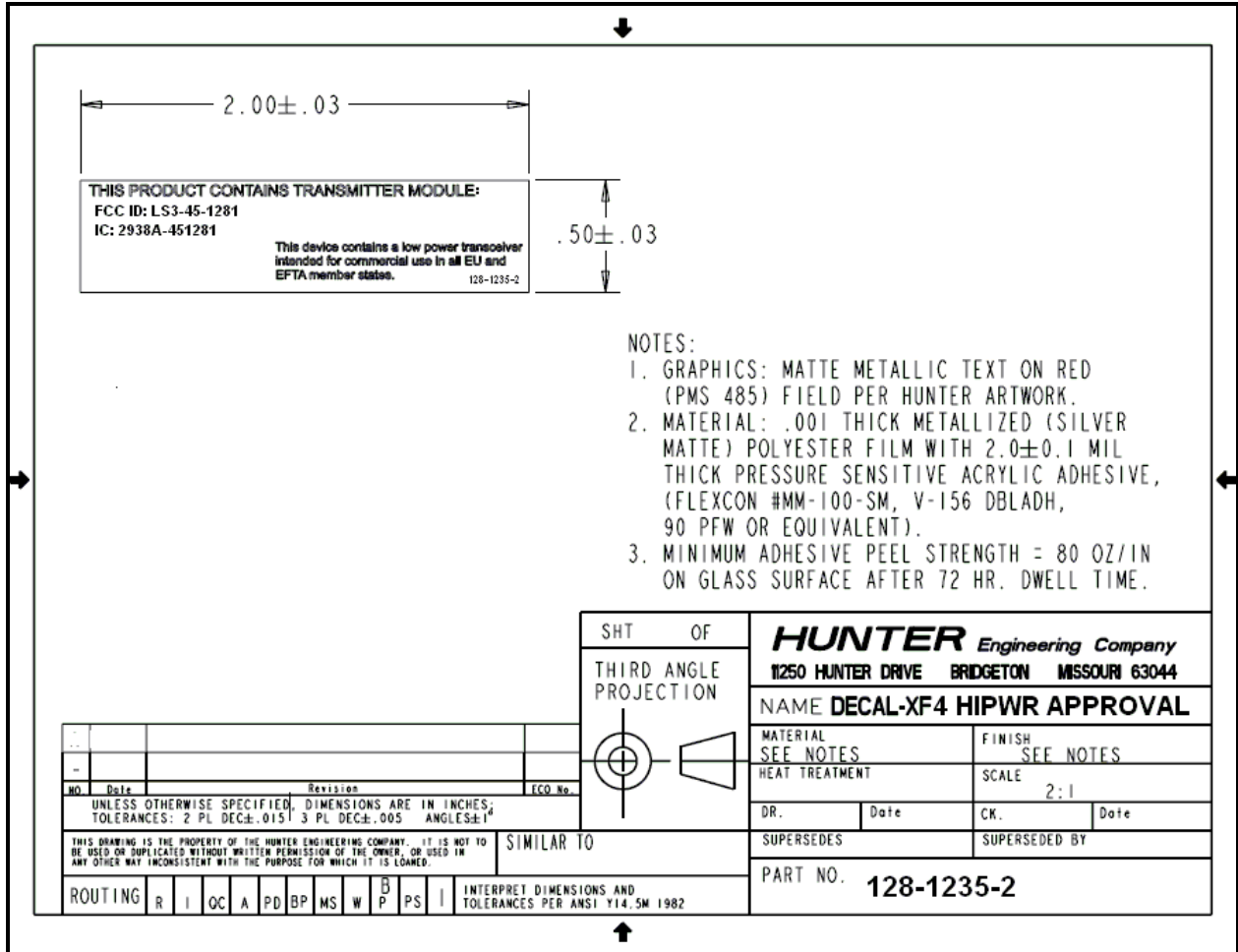

Photograph 2: Sample “Contains FCC ID.....” Label Sample