

EMC Test Report

Application for Grant of Equipment Authorization

Industry Canada RSS-Gen Issue 3 / RSS 210 Issue 8 FCC Part 15 Subpart C

Model: WB-1000

IC CERTIFICATION #: 2390A-WB1000
FCC ID: LRUWB1000

APPLICANT: Pyramid Communications
37 Shield
Irvine, CA 92618

TEST SITE(S): National Technical Systems - Silicon Valley
41039 Boyce Road.
Fremont, CA. 94538-2435

IC SITE REGISTRATION #: 2845B-4

REPORT DATE: March 20, 2014

REISSUE DATE: April 18, 2014

FINAL TEST DATES: February 19, 20, 21 and 24 and March 4, 2014

TOTAL NUMBER OF PAGES: 59

PROGRAM MGR /
TECHNICAL REVIEWER:



Mark E Hill
Staff Engineer

QUALITY ASSURANCE DELEGATE /
FINAL REPORT PREPARER:



David Guidotti
Senior Technical Writer



National Technical Systems - Silicon Valley is accredited by the A2LA, certificate number 0214.26, to perform the test(s) listed in this report, except where noted otherwise. This report and the information contained herein represent the results of testing test articles identified and selected by the client performed to specifications and/or procedures selected by the client. National Technical Systems (NTS) makes no representations, expressed or implied, that such testing is adequate (or inadequate) to demonstrate efficiency, performance, reliability, or any other characteristic of the articles being tested, or similar products. This report should not be relied upon as an endorsement or certification by NTS of the equipment tested, nor does it represent any statement whatsoever as to its merchantability or fitness of the test article, or similar products, for a particular purpose. This report shall not be reproduced except in full

REVISION HISTORY

Rev#	Date	Comments	Modified By
-	March 20, 2014	First release	
1	April 9, 2014	Reissued to revise Radiated spurious emissions test data in Appendix B	MEH / DMG
2	April 18, 2014	Added clarification comment about channel plan vs tested frequencies	MEH

TABLE OF CONTENTS

REVISION HISTORY	2
TABLE OF CONTENTS	3
SCOPE.....	4
OBJECTIVE	4
STATEMENT OF COMPLIANCE.....	5
DEVIATIONS FROM THE STANDARDS.....	5
TEST RESULTS SUMMARY	6
FREQUENCY HOPPING SPREAD SPECTRUM (902 – 928 MHZ, 50 CHANNELS OR MORE)	6
GENERAL REQUIREMENTS APPLICABLE TO ALL BANDS.....	6
MEASUREMENT UNCERTAINTIES.....	7
EQUIPMENT UNDER TEST (EUT) DETAILS.....	8
GENERAL.....	8
OTHER EUT DETAILS.....	8
ANTENNA SYSTEM	8
ENCLOSURE.....	8
MODIFICATIONS.....	8
SUPPORT EQUIPMENT.....	8
EUT INTERFACE PORTS	9
EUT OPERATION	9
TEST SITE.....	10
GENERAL INFORMATION.....	10
CONDUCTED EMISSIONS CONSIDERATIONS	10
RADIATED EMISSIONS CONSIDERATIONS	10
MEASUREMENT INSTRUMENTATION	11
RECEIVER SYSTEM	11
INSTRUMENT CONTROL COMPUTER	11
LINE IMPEDANCE STABILIZATION NETWORK (LISN).....	11
FILTERS/ATTENUATORS	11
ANTENNAS.....	12
ANTENNA MAST AND EQUIPMENT TURNTABLE.....	12
INSTRUMENT CALIBRATION.....	12
TEST PROCEDURES	13
EUT AND CABLE PLACEMENT	13
CONDUCTED EMISSIONS.....	13
RADIATED EMISSIONS	14
CONDUCTED EMISSIONS FROM ANTENNA PORT	16
BANDWIDTH MEASUREMENTS	16
SPECIFICATION LIMITS AND SAMPLE CALCULATIONS	17
CONDUCTED EMISSIONS SPECIFICATION LIMITS: FCC 15.207; FCC 15.107(A), RSS GEN	17
GENERAL TRANSMITTER RADIATED EMISSIONS SPECIFICATION LIMITS	18
RECEIVER RADIATED SPURIOUS EMISSIONS SPECIFICATION LIMITS.....	18
OUTPUT POWER LIMITS – FHSS SYSTEMS	19
TRANSMIT MODE SPURIOUS RADIATED EMISSIONS LIMITS – FHSS AND DTS SYSTEMS.....	19
SAMPLE CALCULATIONS - CONDUCTED EMISSIONS	19
SAMPLE CALCULATIONS - RADIATED EMISSIONS.....	20
SAMPLE CALCULATIONS - FIELD STRENGTH TO EIRP CONVERSION.....	21
APPENDIX A TEST EQUIPMENT CALIBRATION DATA	22
APPENDIX B TEST DATA	24
END OF REPORT	59

SCOPE

An electromagnetic emissions test has been performed on the Pyramid Communications model WB-1000, pursuant to the following rules:

Industry Canada RSS-Gen Issue 3

RSS 210 Issue 8 “Low-power Licence-exempt Radiocommunication Devices (All Frequency Bands): Category I Equipment”

FCC Part 15 Subpart C

Conducted and radiated emissions data has been collected, reduced, and analyzed within this report in accordance with measurement guidelines set forth in the following reference standards and as outlined in National Technical Systems - Silicon Valley test procedures:

ANSI C63.10-2009

FHSS test procedure DA 00-0705A1

The intentional radiator above has been tested in a simulated typical installation to demonstrate compliance with the relevant Industry Canada performance and procedural standards.

Final system data was gathered in a mode that tended to maximize emissions by varying orientation of EUT, orientation of power and I/O cabling, antenna search height, and antenna polarization.

Every practical effort was made to perform an impartial test using appropriate test equipment of known calibration. All pertinent factors have been applied to reach the determination of compliance.

OBJECTIVE

The primary objective of the manufacturer is compliance with the regulations outlined in the previous section.

Prior to marketing in the USA, all unlicensed transmitters and transceivers require certification. Receive-only devices operating between 30 MHz and 960 MHz are subject to either certification or a manufacturer’s declaration of conformity, with all other receive-only devices exempt from the technical requirements.

Prior to marketing in Canada, Class I transmitters, receivers and transceivers require certification. Class II devices are required to meet the appropriate technical requirements but are exempt from certification requirements.

Certification is a procedure where the manufacturer submits test data and technical information to a certification body and receives a certificate or grant of equipment authorization upon successful completion of the certification body's review of the submitted documents. Once the equipment authorization has been obtained, the label indicating compliance must be attached to all identical units, which are subsequently manufactured.

Maintenance of compliance is the responsibility of the manufacturer. Any modification of the product which may result in increased emissions should be checked to ensure compliance has been maintained (i.e., printed circuit board layout changes, different line filter, different power supply, harnessing or I/O cable changes, etc.).

STATEMENT OF COMPLIANCE

The tested sample of Pyramid Communications model WB-1000 complied with the requirements of the following regulations:

Industry Canada RSS-Gen Issue 3
RSS 210 Issue 8 "Low-power Licence-exempt Radiocommunication Devices (All Frequency Bands): Category I Equipment"
FCC Part 15 Subpart C

Maintenance of compliance is the responsibility of the manufacturer. Any modifications to the product should be assessed to determine their potential impact on the compliance status of the device with respect to the standards detailed in this test report.

The test results recorded herein are based on a single type test of Pyramid Communications model WB-1000 and therefore apply only to the tested sample. The sample was selected and prepared by Chris Carbajal of Pyramid Communications.

DEVIATIONS FROM THE STANDARDS

No deviations were made from the published requirements listed in the scope of this report.

TEST RESULTS SUMMARY**FREQUENCY HOPPING SPREAD SPECTRUM (902 – 928 MHz, 50 channels or more)**

FCC Rule Part	RSS Rule Part	Description	Measured Value / Comments	Limit / Requirement	Result
15.247 (a) (1)	RSS 210 A8.1 (1)	20dB Bandwidth	178 kHz	Channel spacing > 20dB bandwidth / 25kHz	Complies
		Channel Separation	251 kHz		Complies
15.247 (a) (1) (i)	RSS 210 A8.1 (3)	Number of Channels	902-915: 50Channels 915-928: 50Channels	50 or more	Complies
15.247 (a) (1) (i)	RSS 210 A8.1 (3)	Channel Dwell Time	397.6ms	<0.4 second within a 20 second period	Complies
15.247 (a) (1)	RSS 210 A8.1 (1)	Channel Utilization	All channels are used equally - refer to the operational description for full explanation	All channels shall, on average, be used equally	Complies
15.247 (b) (3)	RSS 210 A8.4 (1)	Output Power	13.1 dBm (0.02 Watts) EIRP = 0.03 W <small>Note 1</small>	1Watt, EIRP < 4 Watts	Complies
15.247 (c)	RSS 210 A8.5	Antenna Port Spurious Emissions 30MHz – 9.28 GHz	All spurious emissions < -20dBc	< -20dBc	Complies
15.247 (c) 15.209	RSS 210 A8.5 Table 2, 3	Radiated Spurious Emissions 30MHz – 9.28 GHz	37.0 dB μ V/m @ 134.66 MHz (-6.5 dB)	15.207 in restricted bands, all others < -20dBc	Complies
15.247 (a) (1)	RSS 210 A8.1(2)	Receiver bandwidth	Refer to operational description	Shall match the channel bandwidth	Complies

Note 1: EIRP calculated using antenna gain of 2.2 dBi for the highest EIRP system.

GENERAL REQUIREMENTS APPLICABLE TO ALL BANDS

FCC Rule Part	RSS Rule part	Description	Measured Value / Comments	Limit / Requirement	Result (margin)
15.203	-	RF Connector	Reverse SMA	Unique or integral antenna required	Complies
15.207	RSS GEN Table 4	AC Conducted Emissions	55.3 dB μ V @ 0.567 MHz (-0.7 dB)	Refer to page 17	Complies
15.109	RSS GEN 7.2.3 Table 1	Receiver spurious emissions	33.9 dB μ V/m @ 53.46 MHz (-6.1 dB)	Refer to page 18	Complies
15.247 (b) (5) 15.407 (f)	RSS 102	RF Exposure Requirements	Refer to MPE calculations in separate exhibit, RSS 102 declaration and User Manual statements	Refer to OET 65, FCC Part 1 and RSS 102	Complies
-	RSP 100 RSS GEN 7.1.3	User Manual	See pg 3 of manual	Statement required regarding non-interference	Complies
-	RSP 100 RSS GEN 7.1.2	User Manual	See pg 3 of manual	Statement for products with detachable antenna	Complies
-	RSP 100 RSS GEN 4.6.1	99% Bandwidth	Not required – Annex specifies 20dB bandwidth	Information only	N/A

MEASUREMENT UNCERTAINTIES

ISO/IEC 17025 requires that an estimate of the measurement uncertainties associated with the emissions test results be included in the report. The measurement uncertainties given below are based on a 95% confidence level and were calculated in accordance with UKAS document LAB 34.

Measurement Type	Measurement Unit	Frequency Range	Expanded Uncertainty
RF power, conducted (power meter)	dBm	25 to 7000 MHz	± 0.52 dB
RF power, conducted (Spectrum analyzer)	dBm	25 to 7000 MHz	± 0.7 dB
Conducted emission of transmitter	dBm	25 to 26500 MHz	± 0.7 dB
Conducted emission of receiver	dBm	25 to 26500 MHz	± 0.7 dB
Radiated emission (substitution method)	dBm	25 to 26500 MHz	± 2.5 dB
Radiated emission (field strength)	dB μ V/m	25 to 1000 MHz	± 3.6 dB
		1000 to 40000 MHz	± 6.0 dB
Conducted Emissions (AC Power)	dB μ V	0.15 to 30 MHz	± 2.4 dB

EQUIPMENT UNDER TEST (EUT) DETAILS

GENERAL

The Pyramid Communications model WB-1000 is a frequency hopping spread spectrum radio that is designed to provide coverage for mobile radio users. The WM-1000 was treated as tabletop equipment during testing. The electrical rating of the WB-1000 charger is 100-240 Volts, 50/60 Hz.

The sample was received on February 19, 2014 and tested on February 19, 20, 21 and 24 and March 4, 2014. The EUT consisted of the following component(s):

Company	Model	Description	Serial Number	FCC ID
Pyramid Communications	WB-1000	Wireless Microphone Base	None	LRUWB1000

OTHER EUT DETAILS

The following EUT details should be noted:

- 1) System comprised of a handheld/body worn microphone (WM-1000, approved separately) and a base station mounted in an automobile.⁹⁹
- 2) 902-928 MHz FHSS, proprietary system
- 3) Each can be set to operated in two bands with 50 channels each (902.5-915 MHz) and (915 - 927.5 MHz)
- 4) Sample provide for testing had an offset channel plan from the final product. The final product will operate from 902.5 to 927.25MHz. The results presented in this report are considered representative of the final product.

ANTENNA SYSTEM

The antenna system consists of 1/4wave dipole antenna, 2.2dBi gain.

ENCLOSURE

The WB-1000 enclosure is primarily constructed of plastic. It measures approximately 10 cm wide by 7 cm deep by 7 cm high.

MODIFICATIONS

No modifications were made to the EUT during the time the product was at NTS Silicon Valley.

SUPPORT EQUIPMENT

No support equipment was used during testing.

EUT INTERFACE PORTS

The I/O cabling configuration during testing was as follows:

Port	Connected To	Description	Cable(s)	
			Shielded or Unshielded	Length(m)
Base Station	Mic	-	-	-
Base Station / Power	AC/DC Adapter	2Wire	Unshielded	1
AC/DC Adapter	AC Mains	-	-	-

EUT OPERATION

During emissions testing the EUT was configured to continuously transmit at the maximum output power. Depending on the test, the device was configured to transmit on a single channel or hopping across multiple frequencies.

TEST SITE**GENERAL INFORMATION**

Final test measurements were taken at the test sites listed below. Pursuant to section 2.948 of the FCC's Rules and section 3.3 of RSP-100, construction, calibration, and equipment data has been filed with the Commission and with industry Canada.

Site	Designation / Registration Numbers		Location
	FCC	Canada	
Chamber 4	US0027	2845B-4	41039 Boyce Road Fremont, CA 94538-2435
Chamber 5		2845B-5	
Chamber 7		2845B-7	

ANSI C63.4 recommends that ambient noise at the test site be at least 6 dB below the allowable limits. Ambient levels are below this requirement. The test site(s) contain separate areas for radiated and conducted emissions testing. Considerable engineering effort has been expended to ensure that the facilities conform to all pertinent requirements of ANSI C63.4.

CONDUCTED EMISSIONS CONSIDERATIONS

Conducted emissions testing is performed in conformance with ANSI C63.10. Measurements are made with the EUT connected to the public power network through a nominal, standardized RF impedance, which is provided by a line impedance stabilization network, known as a LISN. A LISN is inserted in series with each current-carrying conductor in the EUT power cord.

RADIATED EMISSIONS CONSIDERATIONS

The FCC has determined that radiation measurements made in a shielded enclosure are not suitable for determining levels of radiated emissions. Radiated measurements are performed in an open field environment or in a semi-anechoic chamber. The test sites are maintained free of conductive objects within the CISPR defined elliptical area incorporated in ANSI C63.4 guidelines and meet the Normalized Site Attenuation (NSA) requirements of ANSI C63.4.

MEASUREMENT INSTRUMENTATION

RECEIVER SYSTEM

An EMI receiver as specified in CISPR 16-1-1 is used for emissions measurements. The receivers used can measure over the frequency range of 9 kHz up to 2000 MHz. These receivers allow both ease of measurement and high accuracy to be achieved. The receivers have Peak, Average, and CISPR (Quasi-peak) detectors built into their design so no external adapters are necessary. The receiver automatically sets the required bandwidth for the CISPR detector used during measurements. If the repetition frequency of the signal being measured is below 20Hz, peak measurements are made in lieu of Quasi-Peak measurements.

For measurements above the frequency range of the receivers, a spectrum analyzer is utilized because it provides visibility of the entire spectrum along with the precision and versatility required to support engineering analysis. Average measurements above 1000MHz are performed on the spectrum analyzer using the linear-average method with a resolution bandwidth of 1 MHz and a video bandwidth of 10 Hz, unless the signal is pulsed in which case the average (or video) bandwidth of the measuring instrument is reduced to onset of pulse desensitization and then increased.

INSTRUMENT CONTROL COMPUTER

The receivers utilize either a Rohde & Schwarz EZM Spectrum Monitor/Controller or contain an internal Spectrum Monitor/Controller to view and convert the receiver measurements to the field strength at an antenna or voltage developed at the LISN measurement port, which is then compared directly with the appropriate specification limit. This provides faster, more accurate readings by performing the conversions described under Sample Calculations within the Test Procedures section of this report. Results are printed in a graphic and/or tabular format, as appropriate. A personal computer is used to record all measurements made with the receivers.

The Spectrum Monitor provides a visual display of the signal being measured. In addition, the controller or a personal computer run automated data collection programs which control the receivers. This provides added accuracy since all site correction factors, such as cable loss and antenna factors are added automatically.

LINE IMPEDANCE STABILIZATION NETWORK (LISN)

Line conducted measurements utilize a fifty microhenry Line Impedance Stabilization Network as the monitoring point. The LISN used also contains a 250 uH CISPR adapter. This network provides for calibrated radio frequency noise measurements by the design of the internal low pass and high pass filters on the EUT and measurement ports, respectively.

FILTERS/ATTENUATORS

External filters and precision attenuators are often connected between the receiving antenna or LISN and the receiver. This eliminates saturation effects and non-linear operation due to high amplitude transient events.

ANTENNAS

A loop antenna is used below 30 MHz. For the measurement range 30 MHz to 1000 MHz either a combination of a biconical antenna and a log periodic or a bi-log antenna is used. Above 1000 MHz, horn antennas are used. The antenna calibration factors to convert the received voltage to an electric field strength are included with appropriate cable loss and amplifier gain factors to determine an overall site factor, which is then programmed into the test receivers or incorporated into the test software.

ANTENNA MAST AND EQUIPMENT TURNTABLE

The antennas used to measure the radiated electric field strength are mounted on a non-conductive antenna mast equipped with a motor-drive to vary the antenna height. Measurements below 30 MHz are made with the loop antenna at a fixed height of 1m above the ground plane.

ANSI C63.10 specifies that the test height above ground for table mounted devices shall be 80 centimeters. Floor mounted equipment shall be placed on the ground plane if the device is normally used on a conductive floor or separated from the ground plane by insulating material from 3 to 12 mm if the device is normally used on a non-conductive floor as specified in ANSI C63.4. During radiated measurements, the EUT is positioned on a motorized turntable in conformance with this requirement.

INSTRUMENT CALIBRATION

All test equipment is regularly checked to ensure that performance is maintained in accordance with the manufacturer's specifications. All antennas are calibrated at regular intervals with respect to tuned half-wave dipoles. An exhibit of this report contains the list of test equipment used and calibration information.

TEST PROCEDURES

EUT AND CABLE PLACEMENT

The regulations require that interconnecting cables be connected to the available ports of the unit and that the placement of the unit and the attached cables simulate the worst case orientation that can be expected from a typical installation, so far as practicable. To this end, the position of the unit and associated cabling is varied within the guidelines of ANSI C63.10, and the worst-case orientation is used for final measurements.

CONDUCTED EMISSIONS

Conducted emissions are measured at the plug end of the power cord supplied with the EUT. Excess power cord length is wrapped in a bundle between 30 and 40 centimeters in length near the center of the cord. Preliminary measurements are made to determine the highest amplitude emission relative to the specification limit for all the modes of operation. Placement of system components and varying of cable positions are performed in each mode. A final peak mode scan is then performed in the position and mode for which the highest emission was noted on all current carrying conductors of the power cord.

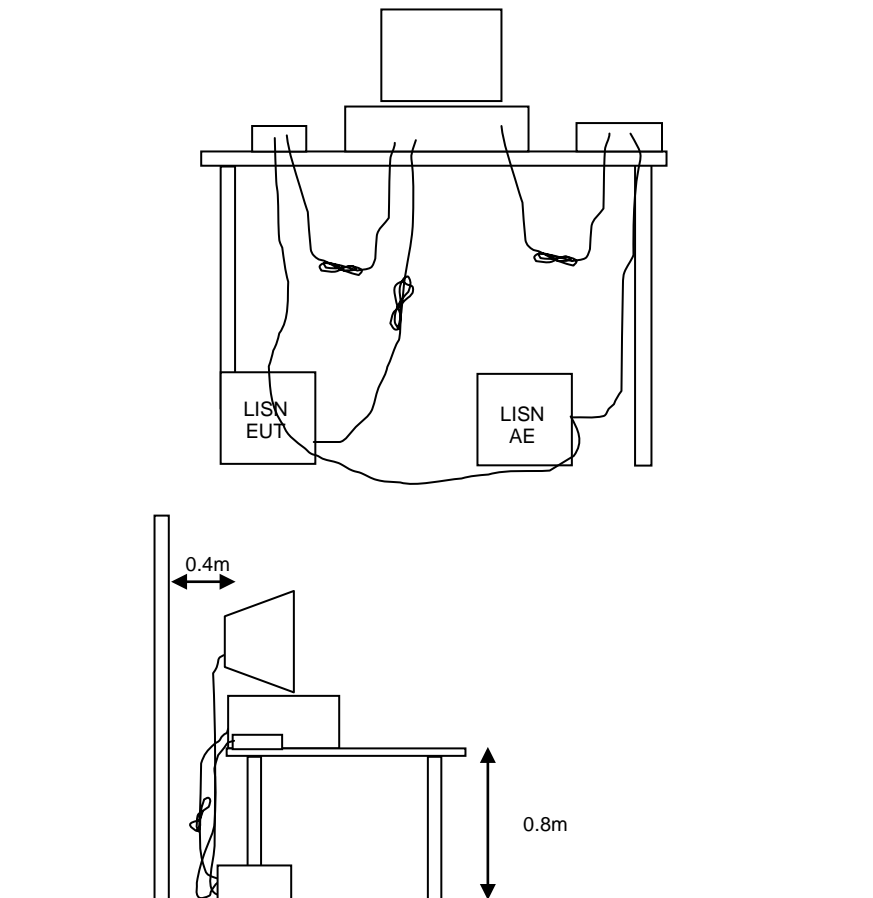

Figure 1 Typical Conducted Emissions Test Configuration

RADIATED EMISSIONS

A preliminary scan of the radiated emissions is performed in which all significant EUT frequencies are identified with the system in a nominal configuration. At least two scans are performed, one scan for each antenna polarization (horizontal and vertical; loop parallel and perpendicular to the EUT). During the preliminary scans, the EUT is rotated through 360°, the antenna height is varied (for measurements above 30 MHz) and cable positions are varied to determine the highest emission relative to the limit. Preliminary scans may be performed in a fully anechoic chamber for the purposes of identifying the frequencies of the highest emissions from the EUT.

A speaker is provided in the receiver to aid in discriminating between EUT and ambient emissions. Other methods used during the preliminary scan for EUT emissions involve scanning with near field magnetic loops, monitoring I/O cables with RF current clamps, and cycling power to the EUT.

Final maximization is a phase in which the highest amplitude emissions identified in the spectral search are viewed while the EUT azimuth angle is varied from 0 to 360 degrees relative to the receiving antenna. The azimuth, which results in the highest emission is then maintained while varying the antenna height from one to four meters (for measurements above 30 MHz, measurements below 30 MHz are made with the loop antenna at a fixed height of 1m). The result is the identification of the highest amplitude for each of the highest peaks. Each recorded level is corrected in the receiver using appropriate factors for cables, connectors, antennas, and preamplifier gain.

When testing above 18 GHz, the receive antenna is located at 1meter from the EUT and the antenna height is restricted to a maximum of 2.5 meters.

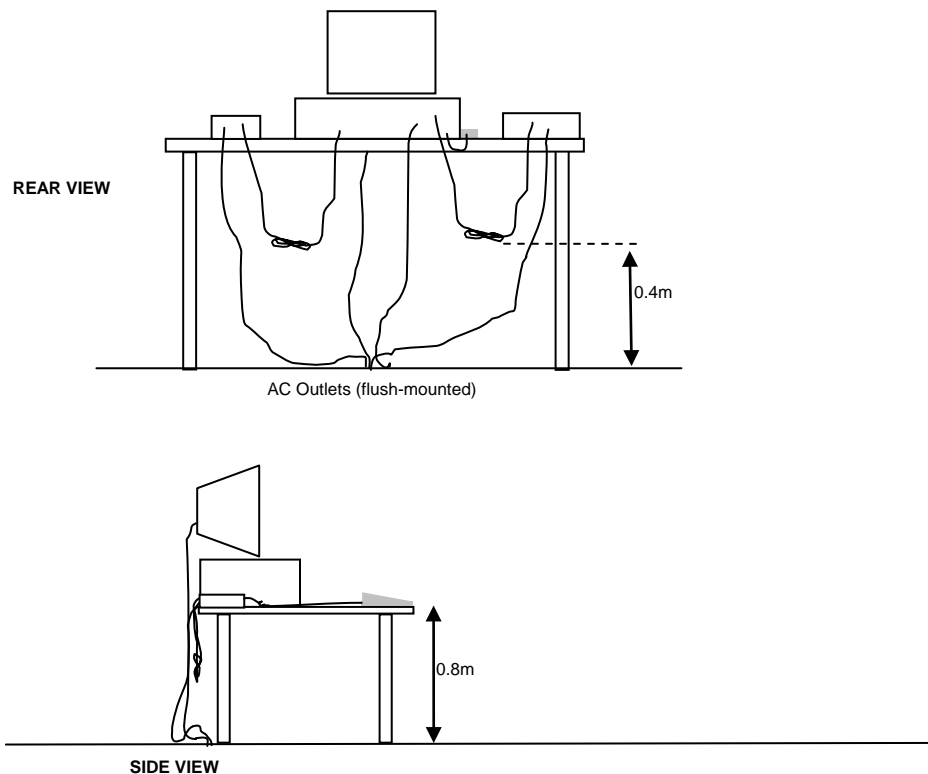

Typical Test Configuration for Radiated Field Strength Measurements

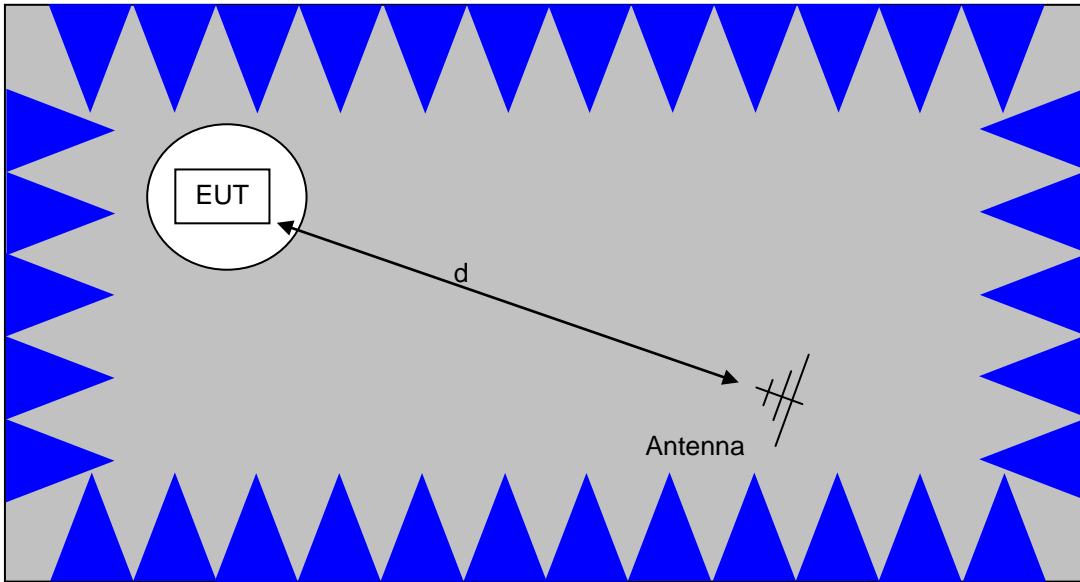

The anechoic materials on the walls and ceiling ensure compliance with the normalized site attenuation requirements of CISPR 16 / CISPR 22 / ANSI C63.4 for an alternate test site at the measurement distances used.

Floor-standing equipment is placed on the floor with insulating supports between the unit and the ground plane.

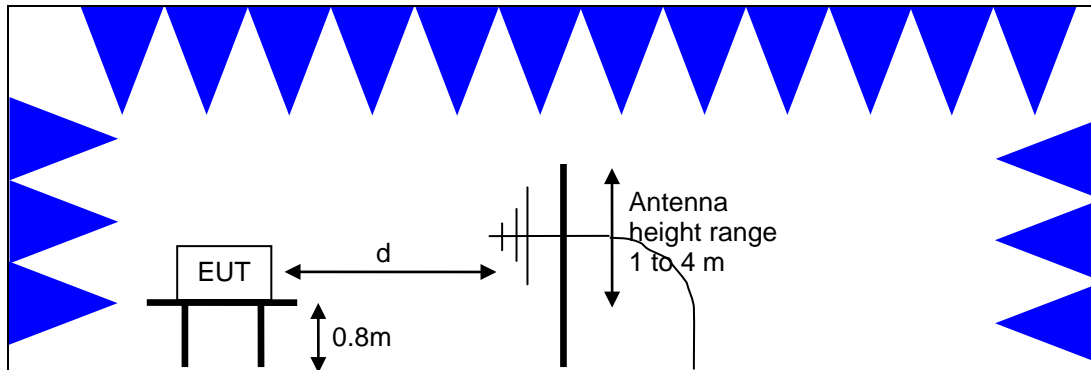

Test Configuration for Radiated Field Strength Measurements
Semi-Anechoic Chamber, Plan and Side Views

CONDUCTED EMISSIONS FROM ANTENNA PORT

Direct measurements of power, bandwidth and power spectral density are performed, where possible, with the antenna port of the EUT connected to either the power meter or spectrum analyzer via a suitable attenuator and/or filter. These are used to ensure that the front end of the measurement instrument is not overloaded by the fundamental transmission.

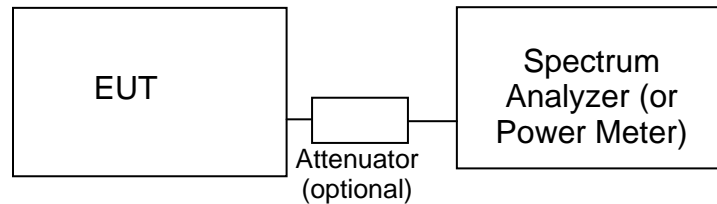
**Test Configuration for Antenna Port Measurements**

Measurement bandwidths (video and resolution) are set in accordance with the relevant standards and NTS Silicon Valley's test procedures for the type of radio being tested. When power measurements are made using a resolution bandwidth less than the signal bandwidth the power is calculated by summing the power across the signal bandwidth using either the analyzer channel power function or by capturing the trace data and calculating the power using software. In both cases the summed power is corrected to account for the equivalent noise bandwidth (ENBW) of the resolution bandwidth used.

If power averaging is used (typically for certain digital modulation techniques), the EUT is configured to transmit continuously. Power averaging is performed using either the built-in function of the analyzer or, if the analyzer does not feature power averaging, using external software. In both cases the average power is calculated over a number of sweeps (typically 100). When the EUT cannot be configured to continuously transmit then either the analyzer is configured to perform a gated sweep to ensure that the power is averaged over periods that the device is transmitting or power averaging is disabled and a max-hold feature is used.

If a power meter is used to make output power measurements the sensor head type (peak or average) is stated in the test data table.

BANDWIDTH MEASUREMENTS

The 6dB, 20dB, 26dB and/or 99% signal bandwidth are measured using the bandwidths recommended by ANSI C63.10 and RSS GEN.

SPECIFICATION LIMITS AND SAMPLE CALCULATIONS

The limits for conducted emissions are given in units of microvolts, and the limits for radiated emissions are given in units of microvolts per meter at a specified test distance. Data is measured in the logarithmic form of decibels relative to one microvolt, or dB microvolts (dBuV). For radiated emissions, the measured data is converted to the field strength at the antenna in dB microvolts per meter (dBuV/m). The results are then converted to the linear forms of uV and uV/m for comparison to published specifications.

For reference, converting the specification limits from linear to decibel form is accomplished by taking the base ten logarithm, then multiplying by 20. These limits in both linear and logarithmic form are as follows:

CONDUCTED EMISSIONS SPECIFICATION LIMITS: FCC 15.207; FCC 15.107(a), RSS GEN

The table below shows the limits for the emissions on the AC power line from an intentional radiator and a receiver.

Frequency (MHz)	Average Limit (dBuV)	Quasi Peak Limit (dBuV)
0.150 to 0.500	Linear decrease on logarithmic frequency axis between 56.0 and 46.0	Linear decrease on logarithmic frequency axis between 66.0 and 56.0
0.500 to 5.000	46.0	56.0
5.000 to 30.000	50.0	60.0

GENERAL TRANSMITTER RADIATED EMISSIONS SPECIFICATION LIMITS

The table below shows the limits for the spurious emissions from transmitters that fall in restricted bands¹ (with the exception of transmitters operating under FCC Part 15 Subpart D and RSS 210 Annex 9), the limits for all emissions from a low power device operating under the general rules of RSS 310 (tables 3 and 4), RSS 210 (table 2) and FCC Part 15 Subpart C section 15.209.

Frequency Range (MHz)	Limit (uV/m)	Limit (dBuV/m @ 3m)
0.009-0.490	$2400/F_{\text{KHz}} @ 300\text{m}$	$67.6-20*\log_{10}(F_{\text{KHz}}) @ 300\text{m}$
0.490-1.705	$24000/F_{\text{KHz}} @ 30\text{m}$	$87.6-20*\log_{10}(F_{\text{KHz}}) @ 30\text{m}$
1.705 to 30	30 @ 30m	29.5 @ 30m
30 to 88	100 @ 3m	40 @ 3m
88 to 216	150 @ 3m	43.5 @ 3m
216 to 960	200 @ 3m	46.0 @ 3m
Above 960	500 @ 3m	54.0 @ 3m

RECEIVER RADIATED SPURIOUS EMISSIONS SPECIFICATION LIMITS

The table below shows the limits for the spurious emissions from receivers as detailed in FCC Part 15.109, RSS 210 Table 2, RSS GEN Table 1 and RSS 310 Table 3. Note that receivers operating outside of the frequency range 30 MHz – 960 MHz are exempt from the requirements of 15.109.

Frequency Range (MHz)	Limit (uV/m @ 3m)	Limit (dBuV/m @ 3m)
30 to 88	100	40
88 to 216	150	43.5
216 to 960	200	46.0
Above 960	500	54.0

¹ The restricted bands are detailed in FCC 15.203, RSS 210 Table 1 and RSS 310 Table 2

OUTPUT POWER LIMITS – FHSS SYSTEMS

The table below shows the limits for output power based on the number of channels available for the hopping system.

Operating Frequency (MHz)	Number of Channels	Output Power
902 – 928	≥ 50	1 Watt (30 dBm)
902 – 928	25 to 49	0.25 Watts (24 dBm)
2400 – 2483.5	≥ 75	1 Watt (30 dBm)
2400 – 2483.5	< 75	0.125 Watts (21 dBm)
5725 – 5850	75	1 Watt (30 dBm)

The maximum permitted output power is reduced by 1dB for every dB the antenna gain exceeds 6dBi. Fixed point-to-point applications using the 5725 – 5850 MHz band are not subject to this restriction.

TRANSMIT MODE SPURIOUS RADIATED EMISSIONS LIMITS – FHSS and DTS SYSTEMS

The limits for unwanted (spurious) emissions from the transmitter falling in the restricted bands are those specified in the general limits sections of FCC Part 15 and RSS 210. All other unwanted (spurious) emissions shall be at least 20dB below the level of the highest in-band signal level (30dB if the power is measured using the sample detector/power averaging method).

SAMPLE CALCULATIONS - CONDUCTED EMISSIONS

Receiver readings are compared directly to the conducted emissions specification limit (decibel form) as follows:

$$R_r - S = M$$

where:

R_r = Receiver Reading in dBuV

S = Specification Limit in dBuV

M = Margin to Specification in +/- dB

SAMPLE CALCULATIONS - RADIATED EMISSIONS

Receiver readings are compared directly to the specification limit (decibel form). The receiver internally corrects for cable loss, preamplifier gain, and antenna factor. The calculations are in the reverse direction of the actual signal flow, thus cable loss is added and the amplifier gain is subtracted. The Antenna Factor converts the voltage at the antenna coaxial connector to the field strength at the antenna elements.

A distance factor, when used for electric field measurements above 30MHz, is calculated by using the following formula:

$$F_d = 20 * \text{LOG}_{10} (D_m/D_s)$$

where:

$$F_d = \text{Distance Factor in dB}$$

$$D_m = \text{Measurement Distance in meters}$$

$$D_s = \text{Specification Distance in meters}$$

For electric field measurements below 30MHz the extrapolation factor is either determined by making measurements at multiple distances or a theoretical value is calculated using the formula:

$$F_d = 40 * \text{LOG}_{10} (D_m/D_s)$$

Measurement Distance is the distance at which the measurements were taken and Specification Distance is the distance at which the specification limits are based. The antenna factor converts the voltage at the antenna coaxial connector to the field strength at the antenna elements.

The margin of a given emission peak relative to the limit is calculated as follows:

$$R_c = R_r + F_d$$

and

$$M = R_c - L_s$$

where:

$$R_r = \text{Receiver Reading in dBuV/m}$$

$$F_d = \text{Distance Factor in dB}$$

$$R_c = \text{Corrected Reading in dBuV/m}$$

$$L_s = \text{Specification Limit in dBuV/m}$$

$$M = \text{Margin in dB Relative to Spec}$$

SAMPLE CALCULATIONS - FIELD STRENGTH TO EIRP CONVERSION

Where the radiated electric field strength is expressed in terms of the equivalent isotropic radiated power (eirp), or where a field strength measurement of output power is made in lieu of a direct measurement, the following formula is used to convert between eirp and field strength at a distance of d (meters) from the equipment under test:

$$E = \frac{1000000 \sqrt{30 P}}{d} \quad \text{microvolts per meter}$$

where P is the eirp (Watts)

For a measurement at 3m the conversion from a logarithmic value for field strength (dBuV/m) to an eirp power (dBm) is -95.3dB.

Appendix A Test Equipment Calibration Data

<u>Manufacturer</u>	<u>Description</u>	<u>Model</u>	<u>Asset #</u>	<u>Cal Due</u>
Radio Antenna Port (Power and Spurious Emissions), 19-Feb-14				
Agilent Technologies	PSA, Spectrum Analyzer, (installed options, 111, 115, 123, 1DS, B7J, HYX,	E4446A	2139	3/7/2014
Radiated Emissions, 30 - 1,000 MHz, 19-Feb-14				
Sunol Sciences	Biconilog, 30-3000 MHz	JB3	1549	5/30/2015
Rohde & Schwarz	EMI Test Receiver, 20 Hz-40 GHz	ESIB40 (1088.7490.40)	2493	1/11/2015
Radiated Emissions, 30 - 1,000 MHz, 20-Feb-14				
Rohde & Schwarz	EMI Test Receiver, 20 Hz-7 GHz	ESIB7	1538	12/14/2014
Sunol Sciences	Biconilog, 30-3000 MHz	JB3	1657	6/4/2014
Com-Power	Preamplifier, 30-1000 MHz	PA-103	2465	9/13/2014
Radiated Emissions, 1000 - 9,300 MHz, 20-Feb-14				
Hewlett Packard	Microwave Preamplifier, 1- 26.5GHz	8449B	785	10/31/2014
EMCO	Antenna, Horn, 1-18GHz	3115	868	6/19/2014
Filtek	Filter, 1 GHz High Pass	HP12/1000-5BA	955	5/13/2014
Filtek	Filter, 1 GHz High Pass	HP12/1000-5BA	957	5/14/2014
Hewlett Packard	SpecAn 30 Hz -40 GHz, SV (SA40) Red	8564E (84125C)	1148	9/14/2014
Micro-Tronics	High Pass Filter 2700 MHz	HPM50111	2326	3/13/2014
Radiated Emissions, 30 - 1,000 MHz, 21-Feb-14				
Sunol Sciences	Biconilog, 30-3000 MHz	JB3	1548	8/9/2014
Rohde & Schwarz	EMI Test Receiver, 20 Hz-7 GHz	ESIB7	1756	6/8/2014
Com-Power	Preamplifier, 1-1000 MHz	PAM-103	2885	11/1/2014
Radiated Emissions, 1000 - 9,300 MHz, 21-Feb-14				
Hewlett Packard	Microwave Preamplifier, 1- 26.5GHz	8449B	785	10/31/2014
EMCO	Antenna, Horn, 1-18GHz	3115	868	6/19/2014
Filtek	Filter, 1 GHz High Pass	HP12/1000-5BA	955	5/13/2014
Filtek	Filter, 1 GHz High Pass	HP12/1000-5BA	957	5/14/2014
Hewlett Packard	SpecAn 30 Hz -40 GHz, SV (SA40) Red	8564E (84125C)	1148	9/14/2014
Micro-Tronics	High Pass Filter 2700 MHz	HPM50111	2326	3/13/2014
Radio Antenna Port (Power and Spurious Emissions), 24-Feb-14				
Rohde & Schwarz	Power Meter, Single Channel	NRVS	1290	12/10/2014
Rohde & Schwarz	Power Sensor 100 uW - 2 Watts (w/ 20 dB pad, SN BJ5155)	NRV-Z32	1536	12/19/2014
Agilent Technologies	PSA, Spectrum Analyzer, (installed options, 111, 115, 123, 1DS, B7J, HYX,	E4446A	2139	3/7/2014
Conducted Emissions - AC Power Ports, 24-Feb-14				
EMCO	LISN, 10 kHz-100 MHz	3825/2	1293	2/13/2015
Rohde & Schwarz	Pulse Limiter	ESH3 Z2	1594	5/15/2014
Rohde & Schwarz	EMI Test Receiver, 20 Hz-7 GHz	ESIB7	1756	6/8/2014

<u>Manufacturer</u>	<u>Description</u>	<u>Model</u>	<u>Asset #</u>	<u>Cal Due</u>
Antenna Port, 04-Mar-14				
Rohde & Schwarz	Power Meter, Single Channel	NRVS	1290	12/10/2014
Rohde & Schwarz	Power Sensor 100 uW - 2 Watts (w/ 20 dB pad, SN BJ5155)	NRV-Z32	1536	12/19/2014
Agilent Technologies	3Hz -44GHz PSA Spectrum Analyzer	E4446A	2796	2/6/2015

Appendix B Test Data

T94722 Pages 25 - 58



EMC Test Data

Client:	Pyramid Communications	Job Number:	J94394
Product:	WB-1000 (Wireless Basestation)	T-Log Number:	T94722
		Project Manager:	Christine Krebill
Contact:	Chris Carbajal	Project Coordinator:	-
Emissions Standard(s):	FCC 15.247	Class:	-
Immunity Standard(s):	-	Environment:	-

EMC Test Data

For The

Pyramid Communications

Product

WB-1000 (Wireless Basestation)

Date of Last Test: 2/26/2014



EMC Test Data

Client: Pyramid Communications	Job Number: J94394
Model: WB-1000 (Wireless Basestation)	T-Log Number: T94722
	Project Manager: Christine Krebill
Contact: Chris Carbajal	Project Coordinator: -
Standard: FCC 15.247	Class: N/A

Power vs. Data Rate

In normal operating modes the card uses power settings stored on EEPROM to set the output power. For a given nominal output power the actual transmit power normally is reduced as the data rate increases, therefore testing was performed at the data rate in the mode with highest power to determine compliance with the requirements.

The following power measurements were made using a GATED average power meter and with the device configured in a continuous transmit mode on Chain 1 at the various data rates in each mode to verify the highest power mode:

Sample Notes

Sample S/N: NTS 2014-3060

Driver: -

Duty Cycle

Date of Test: 2/19/2014

Test Engineer: Jack Liu

Test Location: FT Lab #4B

Duty cycle measurements performed on the worse case data rate for power.

Notes: Measurements taken with maximum RBW/VBW settings allowed.

Mode	Data Rate	Duty Cycle (x)	Constant DC?	T (ms)	Pwr Cor Factor*	Lin Volt Cor Factor**	Min VBW for FS (Hz)
FHSS	-	0.95	Yes	20.2	0.2410886	0.4821773	50

* Correction factor when using RMS/Power averaging - $10 \cdot \log(1/x)$

** Correction factor when using linear voltage average - $20 \cdot \log(1/x)$

T = Minimum transmission duration

Client: Pyramid Communications	Job Number: J94394
Model: WB-1000 (Wireless Basestation)	T-Log Number: T94722
Contact: Chris Carbajal	Project Manager: Christine Krebill
Standard: FCC 15.247	Project Coordinator: -
	Class: N/A

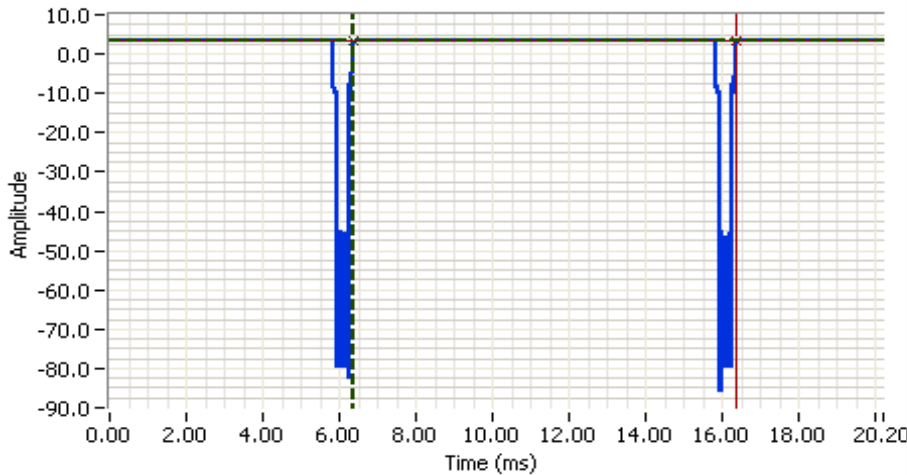

Analyzer Settings
 Agilent Technologies, E4446A
 CF: 915.000 MHz
 SPAN: 0.000 MHz
 RB: 8.000 MHz
 VB: 50.000 MHz
 Detector: Normal
 Attn: 30 DB
 RL Offset: 0.0 DB
 Sweep Time: 20.2ms
 Ref Lvl: 12.0 DBM

Comments
 Cycle time=10ms
 Toff=0.54ms
 Duty Cycle=95%
 WM-1000 (Base)

Cursor 1 6.3665 3.47

Cursor 2 16.3635 3.47

Delta Time (ms) 10.00

Delta Amplitude 0.00

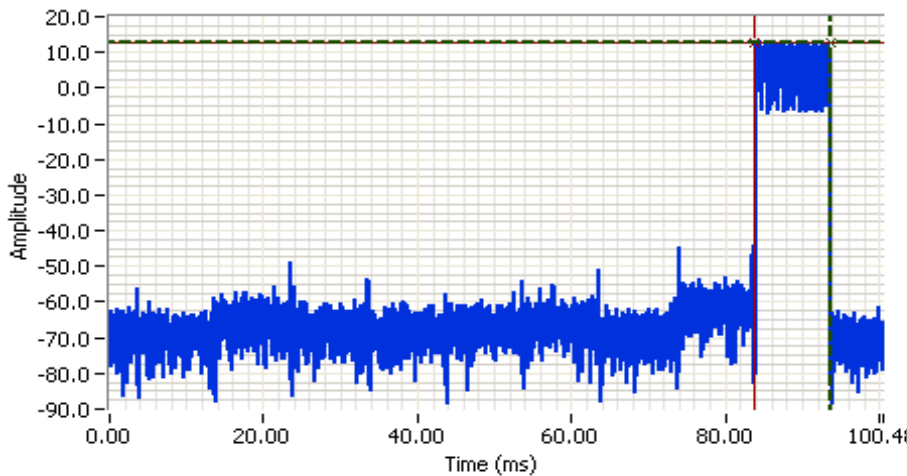

Analyzer Settings
 Agilent Technologies, E4446A
 CF: 907.570 MHz
 SPAN: 0.000 MHz
 RB: 30.0 kHz
 VB: 50.000 MHz
 Detector: POS
 Attn: 20 DB
 RL Offset: 10.5 DB
 Sweep Time: 100.5ms
 Ref Lvl: 20.0 DBM

Comments
 Hopping (Base)
 Ton=9.94ms
 Duty Cycle Correction
 =20dB

Cursor 1 93.6732 12.58

Cursor 2 83.7302 12.58

Delta Time (ms) 9.94

Delta Amplitude 0.00





EMC Test Data

Client:	Pyramid Communications	Job Number:	J94394
Model:	WB-1000 (Wireless Basestation)	T-Log Number:	T94722
		Project Manager:	Christine Krebill
Contact:	Chris Carbajal	Project Coordinator:	-
Standard:	FCC 15.247	Class:	N/A

RSS 210 and FCC 15.247 (DTS) Radiated Spurious Emissions

Test Specific Details

Objective: The objective of this test session is to perform final qualification testing of the EUT with respect to the specification listed above.

General Test Configuration

The EUT and all local support equipment were located on the turntable for radiated spurious emissions testing. For radiated emissions testing the measurement antenna was located 3 meters from the EUT, unless otherwise noted.

Ambient Conditions:

Temperature: 23 °C
Rel. Humidity: 45 %

Summary of Results - Device Operating in the 900 MHz Band

Run #	Mode	Channel	Power Setting	Measured Power	Test Performed	Limit	Result / Margin
1a	Tx	low	default	-	Radiated Emissions, 30 MHz-9.3GHz	FCC Part 15.209 / 15.247(c)	37.0 dBµV/m @ 134.66 MHz (-6.5 dB)
1b	Tx	center	default	-	Radiated Emissions, 30 MHz-9.3GHz	FCC Part 15.209 / 15.247(c)	37.0 dBµV/m @ 134.63 MHz (-6.5 dB)
1c	Tx	high	default	-	Restricted Band at 960 MHz	FCC Part 15.209 / 15.247(c)	44.3 dBµV/m @ 980.00 MHz (-9.7 dB)
			default	-	Radiated Emissions, 30 MHz-9.3GHz	FCC Part 15.209 / 15.247(c)	36.0 dBµV/m @ 132.95 MHz (-7.5 dB)
2a	Rx	low	default	-	Radiated Emissions, 30 MHz-2.8GHz	FCC Part 15.209 / 15.247(c)	33.9 dBµV/m @ 53.46 MHz (-6.1 dB)
2b	Rx	center	default	-	Radiated Emissions, 30 MHz-2.8GHz	FCC Part 15.209 / 15.247(c)	33.6 dBµV/m @ 53.10 MHz (-6.4 dB)
2c	Rx	high	default	-	Radiated Emissions, 30 MHz-2.8GHz	FCC Part 15.209 / 15.247(c)	32.5 dBµV/m @ 54.46 MHz (-7.5 dB)

Modifications Made During Testing

No modifications were made to the EUT during testing

Deviations From The Standard

No deviations were made from the requirements of the standard.



EMC Test Data

Client:	Pyramid Communications	Job Number:	J94394
Model:	WB-1000 (Wireless Basestation)	T-Log Number:	T94722
		Project Manager:	Christine Krebill
Contact:	Chris Carbajal	Project Coordinator:	-
Standard:	FCC 15.247	Class:	N/A

Procedure Comments:

Measurements performed in accordance with FCC KDB 558074

Peak measurements performed with: RBW=1MHz, VBW=3MHz, peak detector, max hold, auto sweep time

Unless otherwise stated/noted, emission has duty cycle $\geq 98\%$ and was measured using RBW=1MHz, VBW=10Hz, peak detector, linear average mode, auto sweep time, max hold.

Mode	Data Rate	Duty Cycle (x)	Constant DC?	T (ms)	Pwr Cor Factor*	Lin Volt Cor Factor**	Min VBW for FS (Hz)
FHSS	-	0.95	Yes	20.2	0.2410886	0.4821773	50

Sample Notes

Sample S/N: NTS 2014-3060

Driver: -

Antenna: 1/4wave dipole

Measurement Specific Notes:

Note 1:	Emission in non-restricted band, but limit of 15.209 used.
Note 2:	Emission in non-restricted band, the limit was set 30dB below the level of the fundamental and measured in 100kHz.
Note 3:	Emission has duty cycle $\geq 98\%$, average measurement performed: RBW=1MHz, VBW=3MHz, RMS, Power averaging, auto sweep, trace average 100 traces
Note 4:	Emission has duty cycle $< 98\%$, but constant, average measurement performed: RBW=1MHz, VBW=10Hz, peak detector, linear averaging, auto sweep, trace average 100 traces, measurement corrected by Linear Voltage correction factor
Note 5:	Emission has duty cycle $< 98\%$ and is NOT constant, average measurement performed: RBW=1MHz, VBW $> 1/T$, peak detector, linear average mode, sweep time auto, max hold. Max hold for $50 \cdot (1/DC)$ traces
Note 6:	Emission has duty cycle $< 98\%$, but constant, average measurement performed: RBW=1MHz, VBW=3MHz, RMS, Power averaging, auto sweep, trace average 100 traces, measurement corrected by Pwr correction factor
Note 7:	Plots of the average and peak bandedge do not account for any duty cycle correction. Refer to the tabluar results for final measurements.
Note 8:	Average result is calculated from Peak reading with Hopping duty cycle correction. Hopping duty cycle correction is 20dB



EMC Test Data

Client: Pyramid Communications	Job Number: J94394
Model: WB-1000 (Wireless Basestation)	T-Log Number: T94722
	Project Manager: Christine Krebill
Contact: Chris Carbajal	Project Coordinator: -
Standard: FCC 15.247	Class: N/A

Run #1: Radiated Spurious Emissions, 30 - 9,300 MHz. Operating Mode:
 Date of Test: 2/19/14 & 2/20/14 Config. Used: 1
 Test Engineer: Jack Liu / R. Varelas Config Change: None
 Test Location: FT chamber# 5& 7 EUT Voltage: 120V/60Hz

Run #1a: Low Channel @ 902.57 MHz

Frequency MHz	Level dB μ V/m	Pol v/h	15.209 / 15.247		Detector Pk/QP/Avg	Azimuth degrees	Height meters	Comments
			Limit	Margin				
134.661	37.0	H	43.5	-6.5	QP	248	2.0	
1805.250	46.0	V	54.0	-8.0	AVG	303	1.3	Note 1
1804.930	48.1	V	74.0	-25.9	PK	303	1.3	Note 1
2707.740	54.9	H	74.0	-19.1	PK	47	1.0	
2707.740	34.9	H	54.0	-19.1	Avg	47	1.0	Note 8
4513.050	56.9	V	74.0	-17.1	PK	0	1.3	
4513.050	36.9	V	54.0	-17.1	AVG	0	1.3	Note 8
8123.370	61.5	V	74.0	-12.5	PK	25	1.0	
8123.370	41.5	V	54.0	-12.5	AVG	25	1.0	Note 8

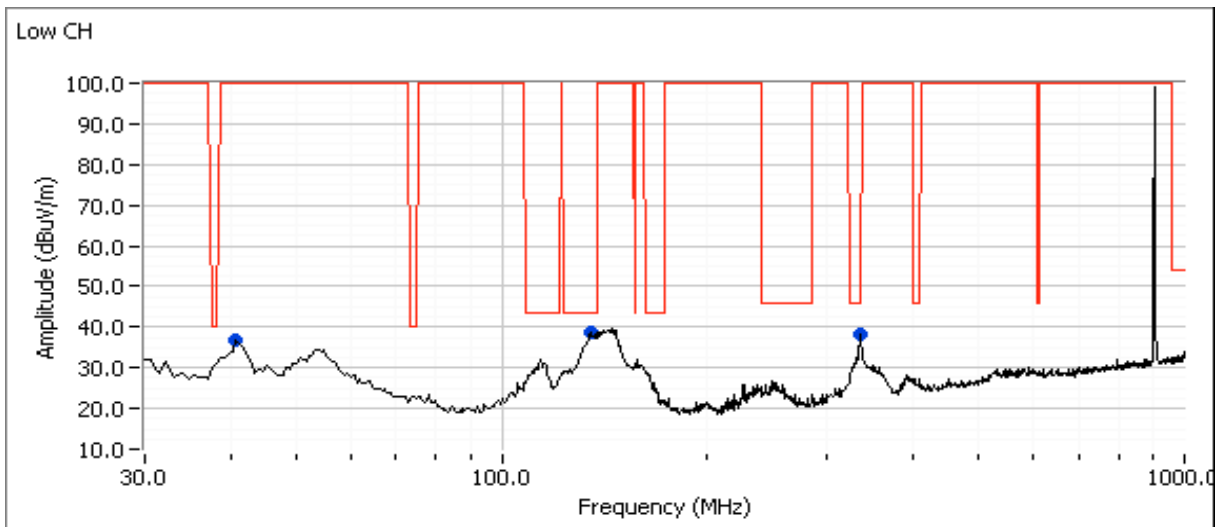

Client: Pyramid Communications	Job Number: J94394
Model: WB-1000 (Wireless Basestation)	T-Log Number: T94722
	Project Manager: Christine Krebill
Contact: Chris Carbajal	Project Coordinator: -
Standard: FCC 15.247	Class: N/A

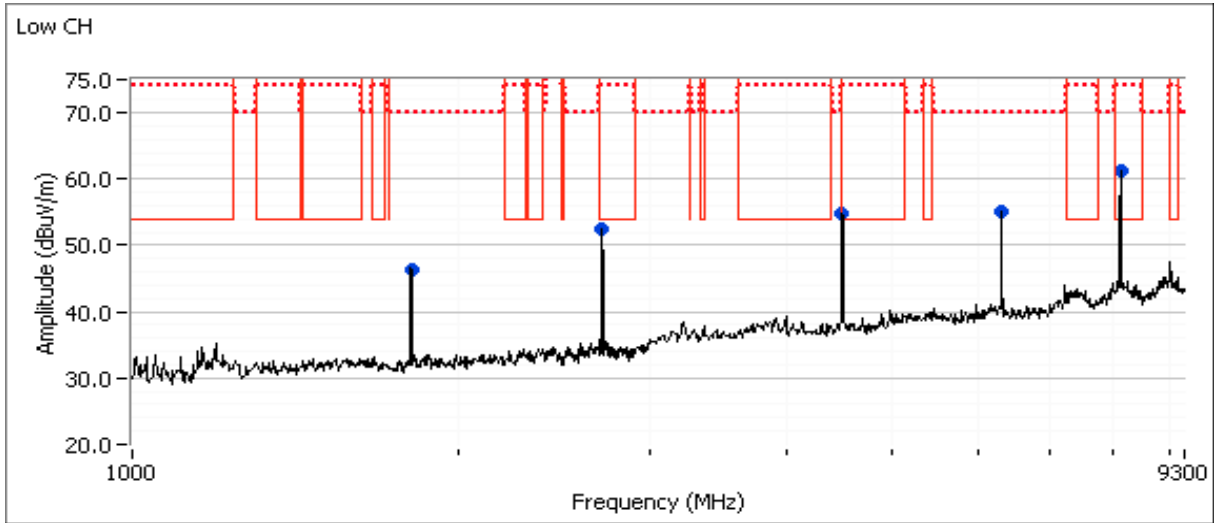



EMC Test Data

Client: Pyramid Communications	Job Number: J94394
Model: WB-1000 (Wireless Basestation)	T-Log Number: T94722
	Project Manager: Christine Krebill
Contact: Chris Carbajal	Project Coordinator: -
Standard: FCC 15.247	Class: N/A

Run #1b: Center Channel @ 914.82 MHz

Frequency MHz	Level dB μ V/m	Pol v/h	15.209 / 15.247		Detector Pk/QP/Avg	Azimuth degrees	Height meters	Comments
			Limit	Margin				
134.626	37.0	H	43.5	-6.5	QP	261	2.0	
247.513	23.9	H	46.0	-22.1	QP	233	1.0	
1829.700	45.8	V	54.0	-8.2	AVG	152	1.2	Note 1
1829.510	48.4	V	74.0	-25.6	PK	152	1.2	Note 1
2744.320	57.3	H	74.0	-16.7	PK	102	1.0	
2744.320	37.3	H	54.0	-16.7	AVG	102	1.0	Note 8
7319.210	54.7	V	74.0	-19.3	PK	74	1.6	
7319.210	34.7	V	54.0	-19.3	AVG	74	1.6	Note 8
8233.010	61.3	V	74.0	-12.7	PK	30	1.0	
8233.010	41.3	V	54.0	-12.7	AVG	30	1.0	Note 8
4574.080	54.7	V	74.0	-19.3	PK	4	1.0	
4574.080	34.7	V	54.0	-19.3	AVG	4	1.0	Note 8

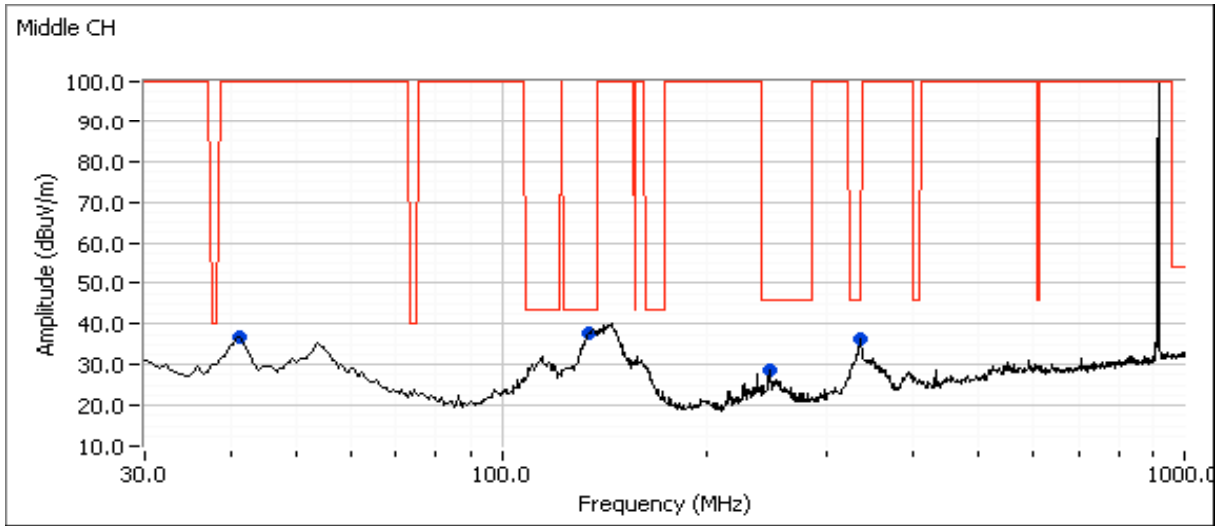

Client: Pyramid Communications	Job Number: J94394
Model: WB-1000 (Wireless Basestation)	T-Log Number: T94722
	Project Manager: Christine Krebill
Contact: Chris Carbajal	Project Coordinator: -
Standard: FCC 15.247	Class: N/A

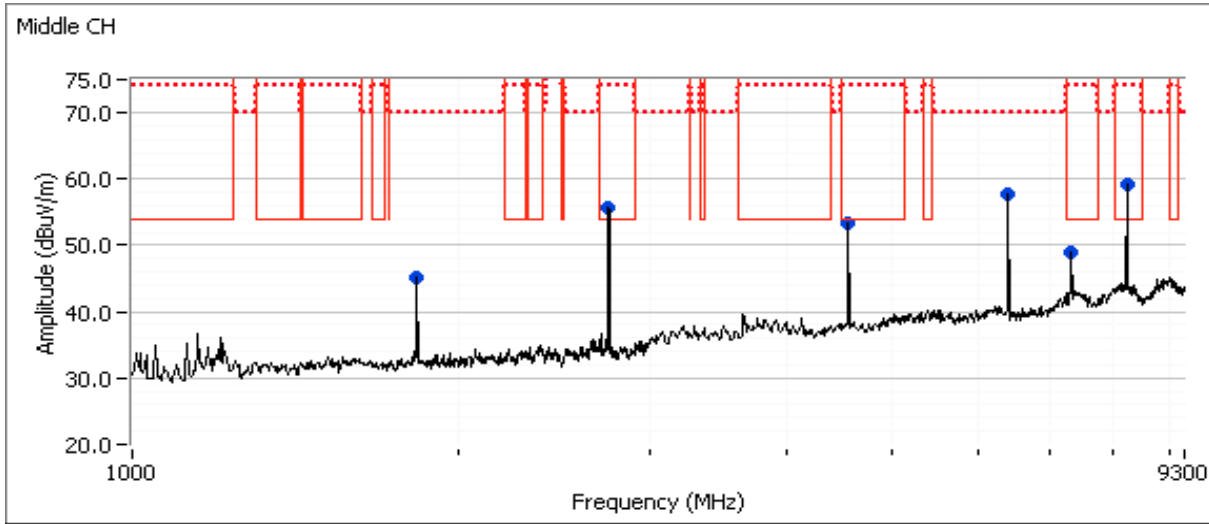

Run #1c: High Channel @ 927.32 MHz

Frequency MHz	Level dB μ V/m	Pol v/h	15.209 / 15.247		Detector Pk/QP/Avg	Azimuth degrees	Height meters	Comments
			Limit	Margin				
980.000	44.3	H	54.0	-9.7	QP	75	1.0	
979.280	33.2	V	54.0	-20.8	QP	59	1.0	

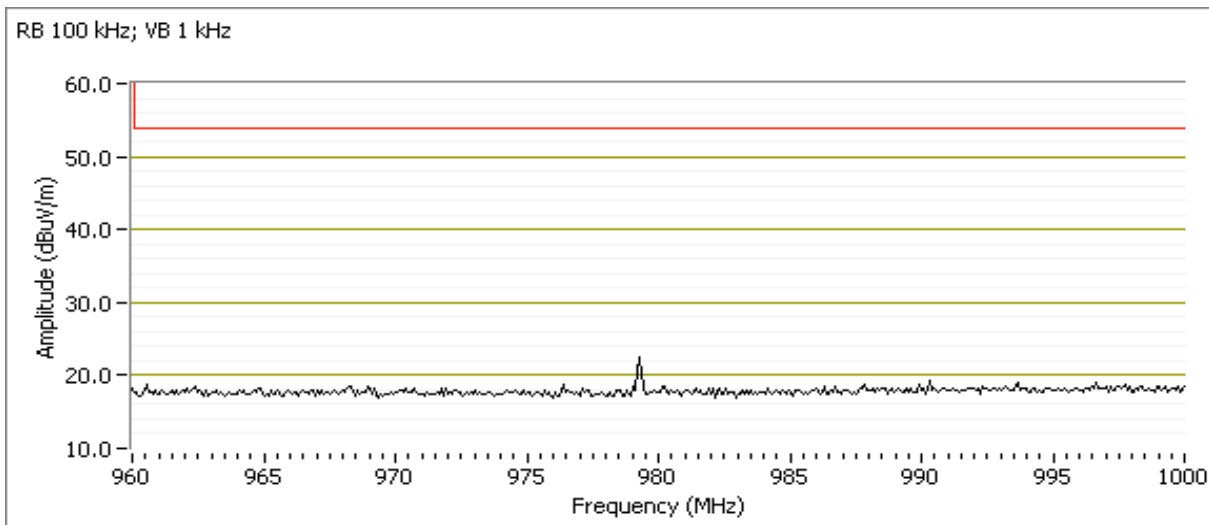



EMC Test Data

Client: Pyramid Communications	Job Number: J94394
Model: WB-1000 (Wireless Basestation)	T-Log Number: T94722
	Project Manager: Christine Krebill
Contact: Chris Carbajal	Project Coordinator: -
Standard: FCC 15.247	Class: N/A

Frequency MHz	Level dB μ V/m	Pol v/h	15.209 / 15.247		Detector PK/QP/Avg	Azimuth degrees	Height meters	Comments
			Limit	Margin				
132.951	36.0	H	43.5	-7.5	QP	249	2.0	
246.214	21.9	H	46.0	-24.1	QP	75	1.0	
330.149	29.2	H	46.0	-16.8	QP	266	1.0	
1854.660	43.0	V	54.0	-11.0	AVG	252	1.5	Note 1
1854.400	47.0	V	74.0	-27.0	PK	252	1.5	Note 1
2782.180	57.5	H	74.0	-16.5	PK	32	1.0	
2782.180	37.5	H	54.0	-16.5	AVG	32	1.0	Note 8
3709.230	50.2	H	74.0	-23.8	PK	303	1.3	
3709.230	30.2	H	54.0	-23.8	AVG	303	1.3	Note 8
8345.240	58.1	V	74.0	-15.9	PK	45	1.5	
8345.240	38.1	V	54.0	-15.9	AVG	45	1.5	Note 8
7418.830	58.0	H	74.0	-16.0	PK	30	1.0	
7418.830	38.0	H	54.0	-16.0	AVG	30	1.0	Note 8
4636.910	54.5	V	74.0	-19.5	PK	2	1.4	
4636.910	34.5	V	74.0	-39.5	AVG	2	1.4	Note 8

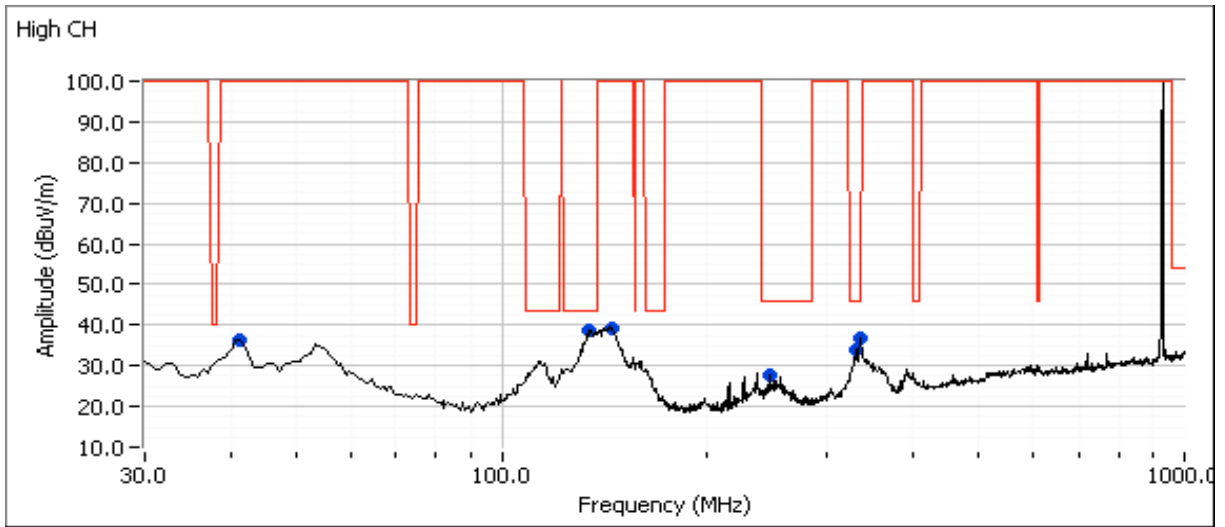



EMC Test Data

Client: Pyramid Communications	Job Number: J94394
Model: WB-1000 (Wireless Basestation)	T-Log Number: T94722
	Project Manager: Christine Krebill
Contact: Chris Carbajal	Project Coordinator: -
Standard: FCC 15.247	Class: N/A

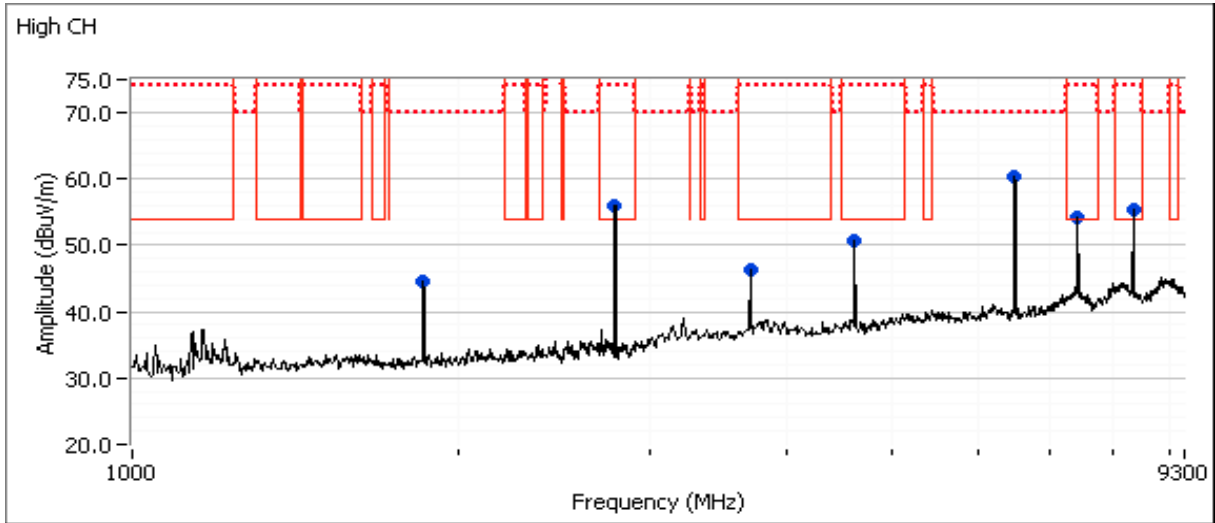



EMC Test Data

Client: Pyramid Communications	Job Number: J94394
Model: WB-1000 (Wireless Basestation)	T-Log Number: T94722
	Project Manager: Christine Krebill
Contact: Chris Carbajal	Project Coordinator: -
Standard: FCC 15.247	Class: N/A

Run #2: Radiated Spurious Emissions, 30 - 2,800 MHz. Operating Mode: Receive
 Date of Test: 2/20/2014 0:00 Config. Used: 1
 Test Engineer: Jack Liu / R. Varelas Config Change: None
 Test Location: FT chamber# 7 EUT Voltage: 120V/60Hz

Run #2a: Low Channel @ 902.57 MHz

Frequency	Level	Pol	15.209 / 15.247		Detector	Azimuth	Height	Comments
MHz	dB μ V/m	v/h	Limit	Margin	PK/QP/Avg	degrees	meters	
53.463	33.9	V	40.0	-6.1	QP	343	1.0	QP (1.00s)
39.751	27.1	V	40.0	-12.9	QP	288	1.0	QP (1.00s)
334.489	30.1	H	46.0	-15.9	QP	263	1.0	QP (1.00s)
142.777	31.9	V	43.5	-11.6	QP	147	1.0	QP (1.00s)
2700.090	34.2	V	54.0	-19.8	AVG	109	2.2	RB 1 MHz;VB 10 Hz;Peak
2700.150	43.5	V	74.0	-30.5	PK	109	2.2	RB 1 MHz;VB 3 MHz;Peak
1030.070	30.9	V	54.0	-23.1	AVG	268	1.6	RB 1 MHz;VB 10 Hz;Peak
1029.960	39.7	V	74.0	-34.3	PK	268	1.6	RB 1 MHz;VB 3 MHz;Peak

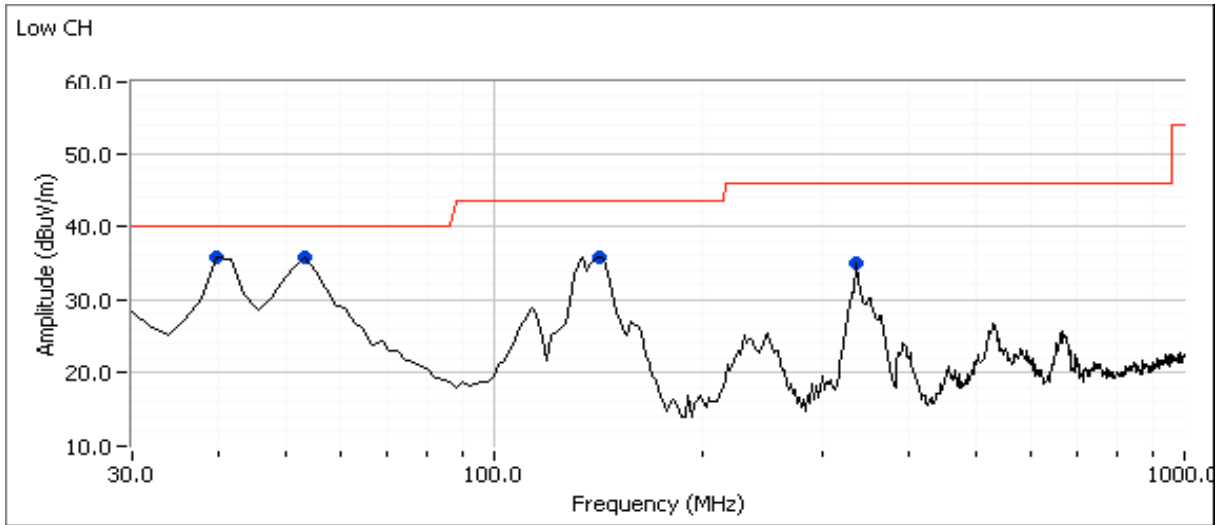



EMC Test Data

Client:	Pyramid Communications	Job Number:	J94394
Model:	WB-1000 (Wireless Basestation)	T-Log Number:	T94722
Contact:	Chris Carbajal	Project Manager:	Christine Krebill
Standard:	FCC 15.247	Project Coordinator:	-
		Class:	N/A

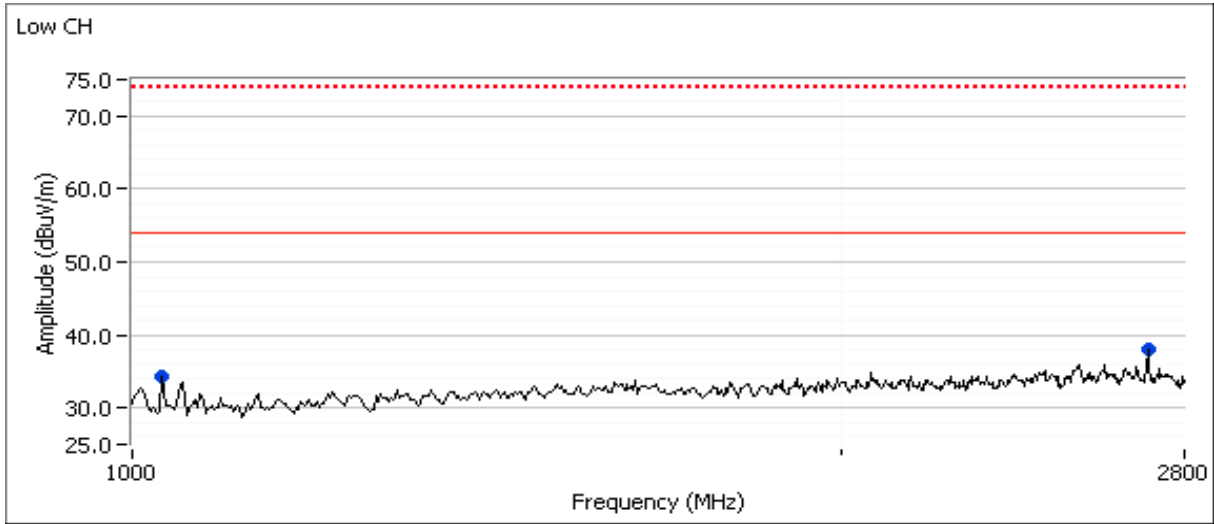



EMC Test Data

Client: Pyramid Communications	Job Number: J94394
Model: WB-1000 (Wireless Basestation)	T-Log Number: T94722
	Project Manager: Christine Krebill
Contact: Chris Carbajal	Project Coordinator: -
Standard: FCC 15.247	Class: N/A

Run #2b: Center Channel @ 914.82 MHz

Frequency MHz	Level dB μ V/m	Pol v/h	15.209 / 15.247		Detector Pk/QP/Avg	Azimuth degrees	Height meters	Comments
			Limit	Margin				
53.104	33.6	V	40.0	-6.4	QP	26	1.0	QP (1.00s)
142.726	33.1	V	43.5	-10.4	QP	228	1.0	QP (1.00s)
40.799	30.7	V	40.0	-9.3	QP	238	1.0	QP (1.00s)
335.914	34.8	H	46.0	-11.2	QP	278	1.0	QP (1.00s)
1030.080	30.4	V	54.0	-23.6	AVG	354	1.6	RB 1 MHz;VB 10 Hz;Peak
1030.270	39.3	V	74.0	-34.7	PK	354	1.6	RB 1 MHz;VB 3 MHz;Peak
2699.960	34.3	V	54.0	-19.7	AVG	334	2.2	RB 1 MHz;VB 10 Hz;Peak
2700.320	43.7	V	74.0	-30.3	PK	334	2.2	RB 1 MHz;VB 3 MHz;Peak

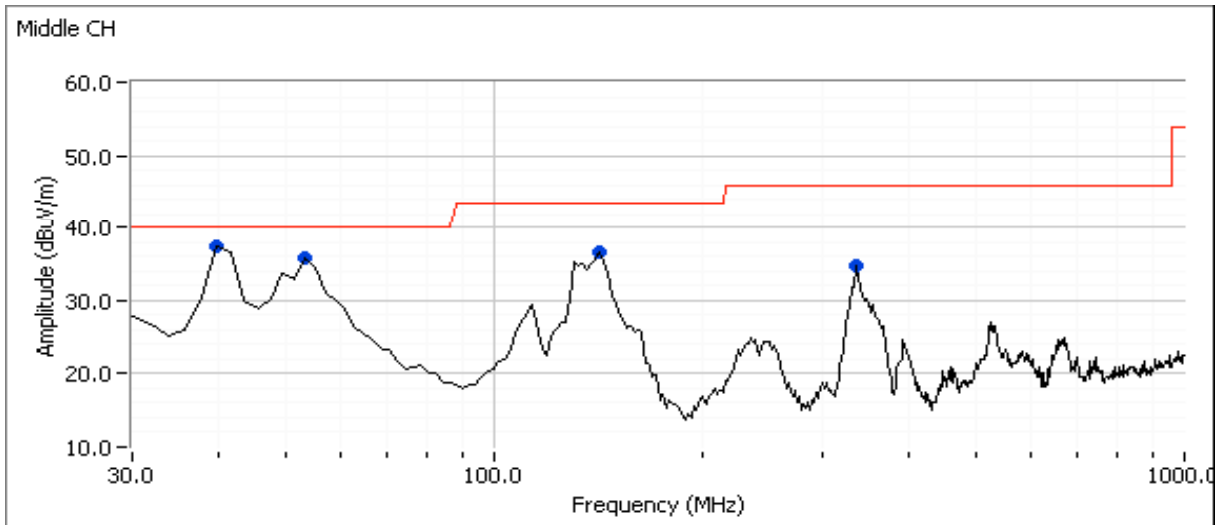



EMC Test Data

Client: Pyramid Communications	Job Number: J94394
Model: WB-1000 (Wireless Basestation)	T-Log Number: T94722
	Project Manager: Christine Krebill
Contact: Chris Carbajal	Project Coordinator: -
Standard: FCC 15.247	Class: N/A

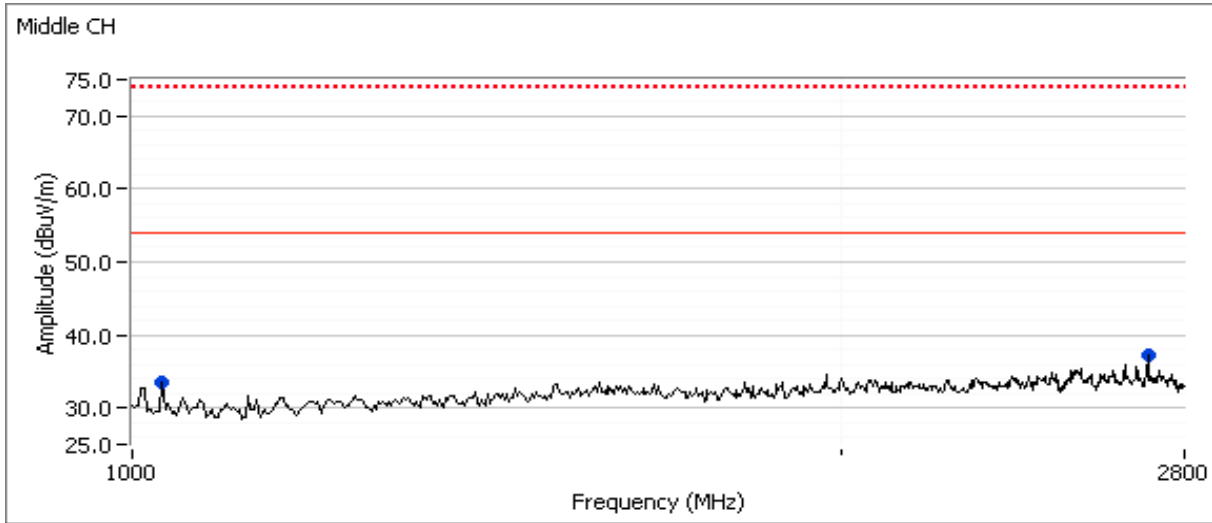



EMC Test Data

Client: Pyramid Communications	Job Number: J94394
Model: WB-1000 (Wireless Basestation)	T-Log Number: T94722
	Project Manager: Christine Krebill
Contact: Chris Carbajal	Project Coordinator: -
Standard: FCC 15.247	Class: N/A

Run #2c: High Channel @ 927.32 MHz

Frequency MHz	Level dB μ V/m	Pol v/h	15.209 / 15.247		Detector Pk/QP/Avg	Azimuth degrees	Height meters	Comments
			Limit	Margin				
54.459	32.5	V	40.0	-7.5	QP	27	1.0	QP (1.00s)
41.016	30.6	V	40.0	-9.4	QP	32	1.5	QP (1.00s)
114.468	27.3	H	43.5	-16.2	QP	252	2.5	QP (1.00s)
134.769	34.0	H	43.5	-9.5	QP	252	2.0	QP (1.00s)
336.004	35.4	H	46.0	-10.6	QP	278	1.0	QP (1.00s)
2700.090	34.3	V	54.0	-19.7	AVG	110	2.2	RB 1 MHz;VB 10 Hz;Peak
2700.380	43.7	V	74.0	-30.3	PK	110	2.2	RB 1 MHz;VB 3 MHz;Peak
1030.010	30.4	V	54.0	-23.6	AVG	34	1.6	RB 1 MHz;VB 10 Hz;Peak
1029.450	40.0	V	74.0	-34.0	PK	34	1.6	RB 1 MHz;VB 3 MHz;Peak

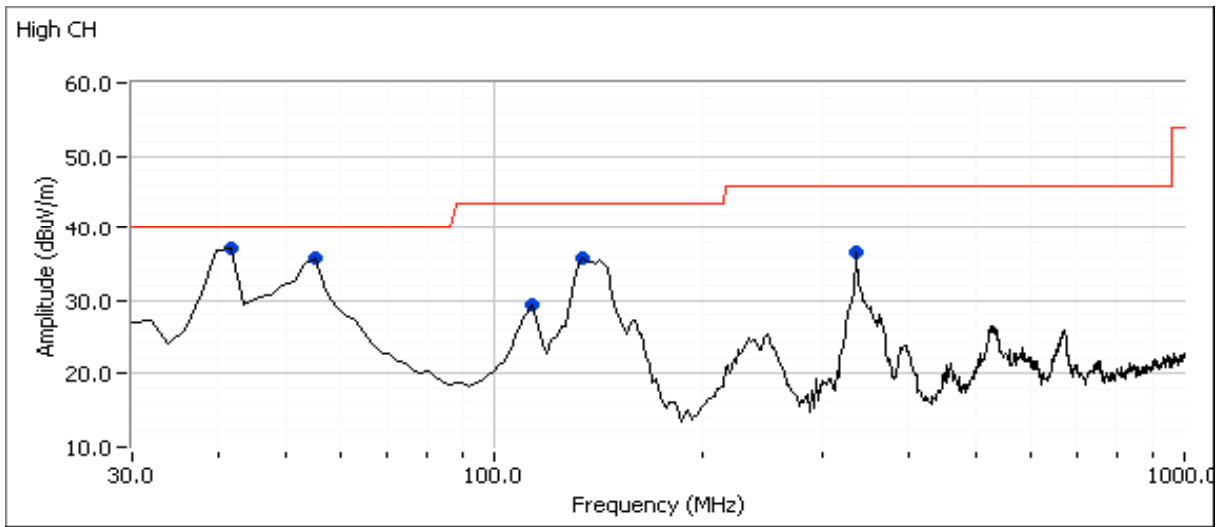



EMC Test Data

Client: Pyramid Communications	Job Number: J94394
Model: WB-1000 (Wireless Basestation)	T-Log Number: T94722
	Project Manager: Christine Krebill
Contact: Chris Carbajal	Project Coordinator: -
Standard: FCC 15.247	Class: N/A

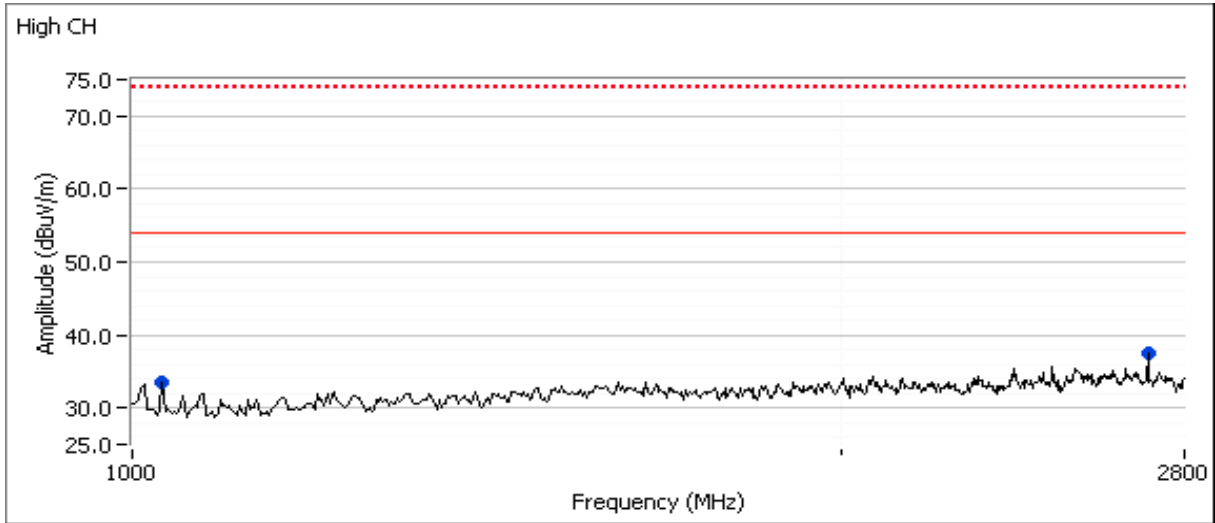



EMC Test Data

Client: Pyramid Communications	Job Number: J94394
Model: WB-1000 (Wireless Basestation)	T-Log Number: T94722
	Project Manager: Christine Krebill
Contact: Chris Carbajal	Project Coordinator: -
Standard: FCC 15.247	Class: N/A

FCC 15.247 FHSS - Power, Bandwidth and Spurious Emissions

Test Specific Details

Objective: The objective of this test session is to perform final qualification testing of the EUT with respect to the specification listed above.

Date of Test: 2/24/2014 and 3/4/14
 Test Engineer: Jack Liu and Mark Hill
 Test Location: FT Chamber #4A

Config. Used: 1
 Config Change: None
 EUT Voltage: 120V/60Hz

General Test Configuration

When measuring the conducted emissions from the EUT's antenna port, the antenna port of the EUT was connected to the spectrum analyzer or power meter via a suitable attenuator to prevent overloading the measurement system. All measurements are corrected to allow for the external attenuators used.

Unless stated otherwise the EUT was operating such that it constantly hopped on either the low, center or high channels.

Ambient Conditions:

Temperature: 24 °C
 Rel. Humidity: 40 %

Summary of Results

Run #	Test Performed	Limit	Pass / Fail	Result / Margin
1	30 - 9,300 MHz - Transmitter Conducted Spurious Emissions	FCC Part 15.247(c)	Pass	All emissions more than 20dB below the highest in-band signal level.
4	Output Power	15.247(b)	Pass	13.1dBm
5	20dB Bandwidth	15.247(a)	Pass	178kHz
5	99% bandwidth			
5	Channel Occupancy	15.247(a)	Pass	397.6ms
5	Number of Channels	15.247(a)	Pass	902-915: 50Channels 915-928: 50Channels
5	Carrier Channel Separation	15.247(a)	Pass	251kHz



EMC Test Data

Client:	Pyramid Communications	Job Number:	J94394
Model:	WB-1000 (Wireless Basestation)	T-Log Number:	T94722
		Project Manager:	Christine Krebill
Contact:	Chris Carbajal	Project Coordinator:	-
Standard:	FCC 15.247	Class:	N/A

Modifications Made During Testing:

No modifications were made to the EUT during testing

Deviations From The Standard

No deviations were made from the requirements of the standard.

Sample Notes

Sample S/N: NTS 2014-3060 & NTS2014-3020

Driver: -

EUT provide two different Channels - Channel 1 operates in the 902-915MHz range, and Channel 2 operates in the 915-928MHz range. The hopping sequence within each Channel is the same.



EMC Test Data

Client: Pyramid Communications	Job Number: J94394
Model: WB-1000 (Wireless Basestation)	T-Log Number: T94722
	Project Manager: Christine Krebill
Contact: Chris Carbajal	Project Coordinator: -
Standard: FCC 15.247	Class: N/A

Run #1: Antenna Conducted Spurious Emissions, 30 - 9,300 MHz.

Refer to plots below. Scans made using RBW=100kHz VB=300KHz with the limit line set at 20dB below the highest in-band signal level with the hopping feature disabled.

Low channel

Broadband plot

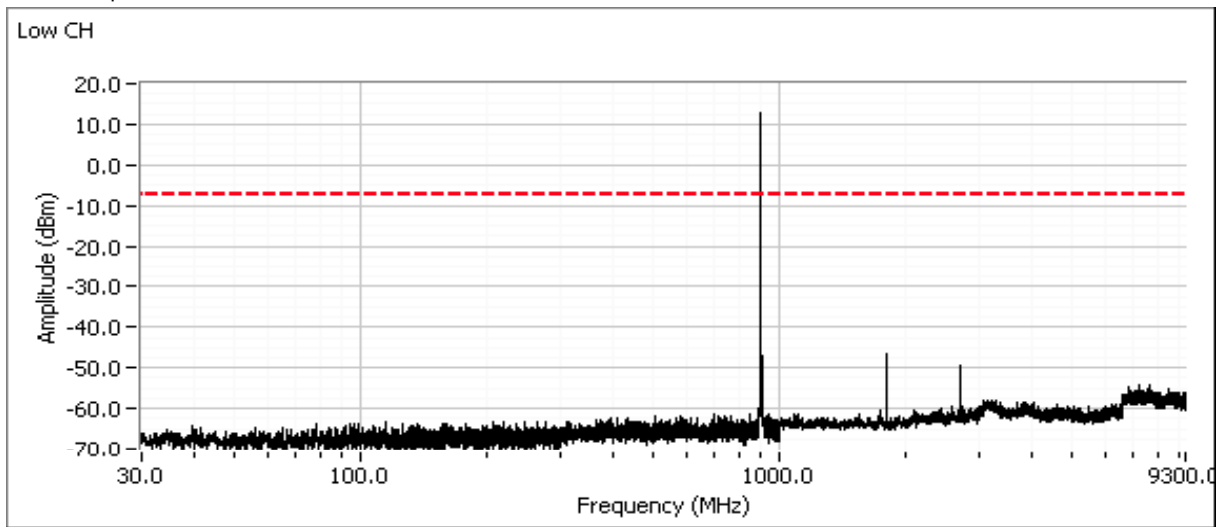

Plot showing -20dBc at the lower band edge

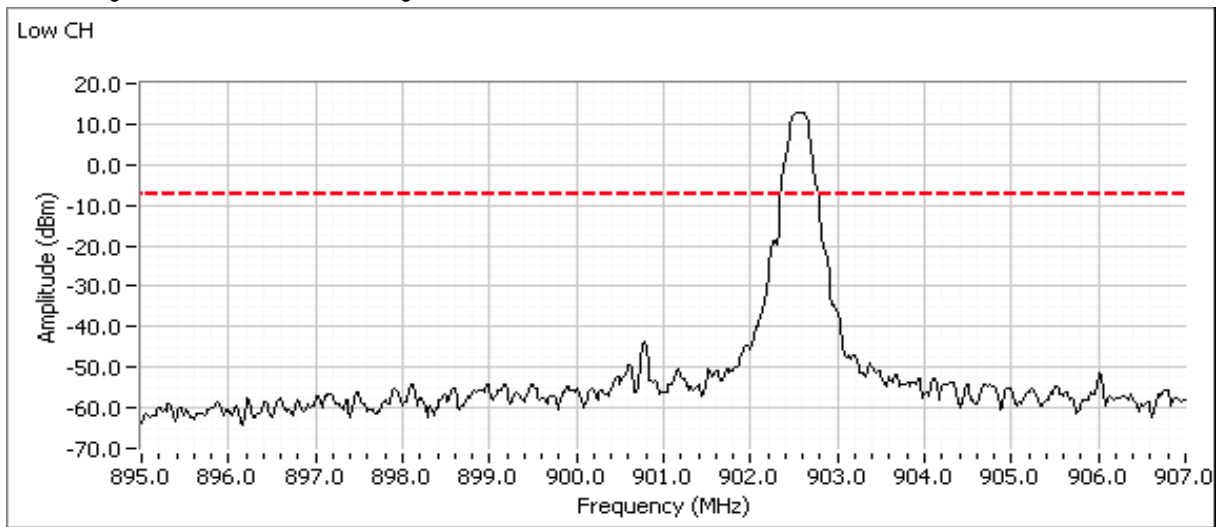



EMC Test Data

Client: Pyramid Communications	Job Number: J94394
Model: WB-1000 (Wireless Basestation)	T-Log Number: T94722
	Project Manager: Christine Krebill
Contact: Chris Carbajal	Project Coordinator: -
Standard: FCC 15.247	Class: N/A

Center channel
Broadband plot

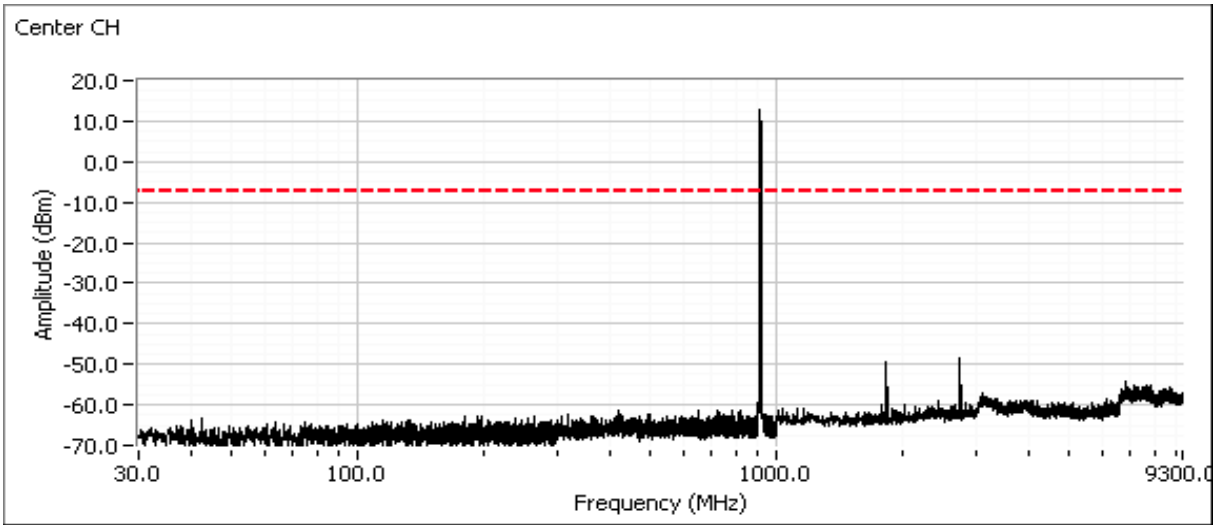

High channel
Broadband plot

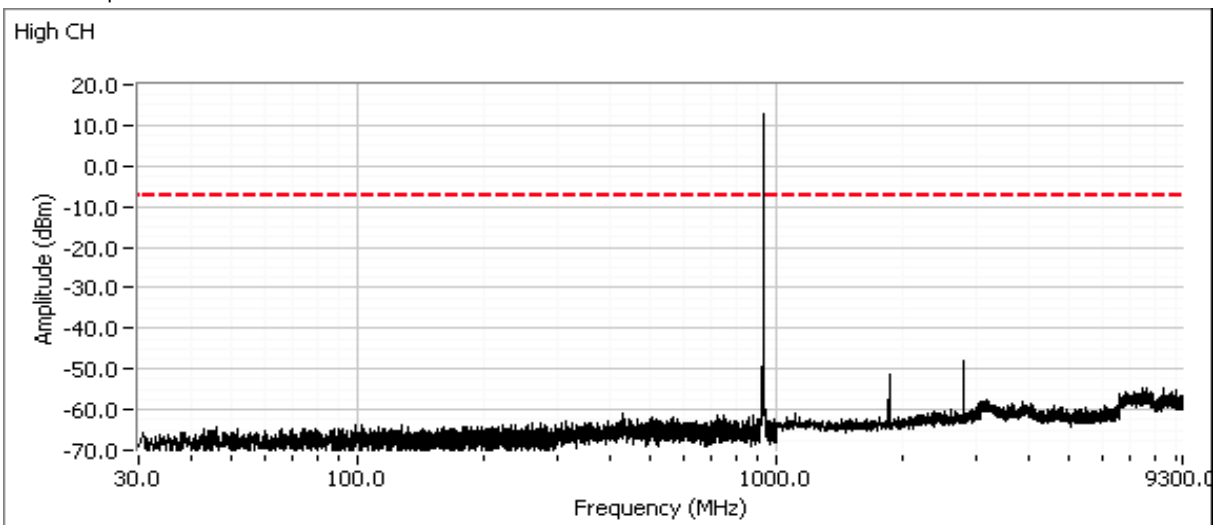



EMC Test Data

Client: Pyramid Communications	Job Number: J94394
Model: WB-1000 (Wireless Basestation)	T-Log Number: T94722
	Project Manager: Christine Krebill
Contact: Chris Carbajal	Project Coordinator: -
Standard: FCC 15.247	Class: N/A

Plot showing -20dBc at the upper band edge

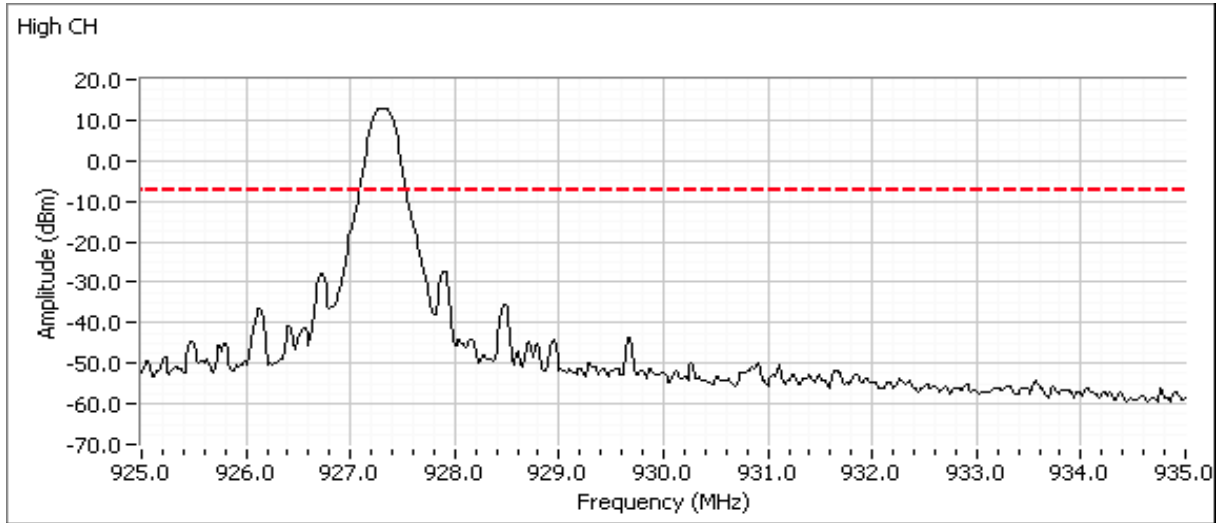



EMC Test Data

Client: Pyramid Communications	Job Number: J94394
Model: WB-1000 (Wireless Basestation)	T-Log Number: T94722
	Project Manager: Christine Krebill
Contact: Chris Carbajal	Project Coordinator: -
Standard: FCC 15.247	Class: N/A

Refer to plots below. Scans made using RBW=100kHz VB=300KHz with the limit line set at 20dB below the highest in-band signal level with the hopping enabled to show compliance with the -20dBc requirement at the allocated band edge. The spectrum analyzer is left in max hold mode until the trace stabilizes.

Low channel, hopping enabled
Plot showing -20dBc at the lower band edge

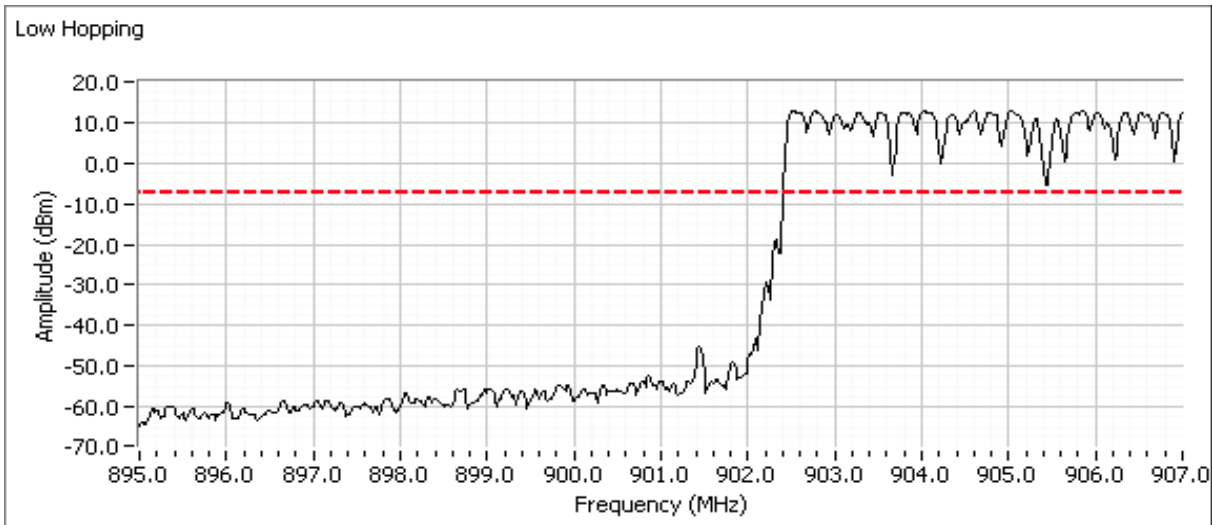



EMC Test Data

Client: Pyramid Communications	Job Number: J94394
Model: WB-1000 (Wireless Basestation)	T-Log Number: T94722
	Project Manager: Christine Krebill
Contact: Chris Carbajal	Project Coordinator: -
Standard: FCC 15.247	Class: N/A

High channel, hopping enabled
Plot showing -20dBc at the upper band edge

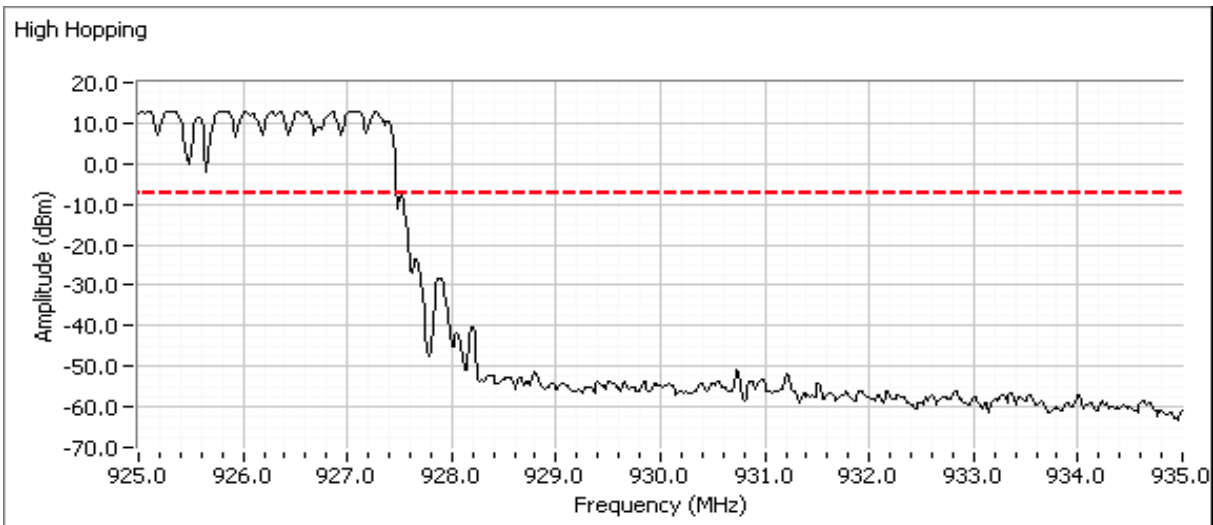



EMC Test Data

Client: Pyramid Communications	Job Number: J94394
Model: WB-1000 (Wireless Basestation)	T-Log Number: T94722
	Project Manager: Christine Krebill
Contact: Chris Carbajal	Project Coordinator: -
Standard: FCC 15.247	Class: N/A

Run #4: Output Power

Date of Test: 3/4/2014

Test Engineer: Mark Hill

Test Location: FT Lab#4

For frequency hopping systems operating in the 902-928 MHz band: 1 watt for systems employing at least 50 hopping channels; and, 0.25 watts for systems employing less than 50 hopping channels, but at least 25 hopping channels.

Maximum antenna gain: 2.2 dBi

Channel	Frequency (MHz)	Res BW	Output Power (dBm)	Output Power (W)	EIRP (W)
Low	902.57	-	13.1	0.0204	0.0339
Mid	914.81	-	13.1	0.0204	0.0339
High	927.32	-	13.1	0.0204	0.0339

Note 1: Output power measured using a peak power meter, spurious limit is -20dBc.



EMC Test Data

Client: Pyramid Communications	Job Number: J94394
Model: WB-1000 (Wireless Basestation)	T-Log Number: T94722
	Project Manager: Christine Krebill
Contact: Chris Carbajal	Project Coordinator: -
Standard: FCC 15.247	Class: N/A

Run #5: Bandwidth, Channel Occupancy, Spacing and Number of Channels

Channel	Frequency (MHz)	Resolution Bandwidth	20dB Bandwidth (kHz)	Resolution Bandwidth	99% Bandwidth (kHz)
Low	902.57	3kHz	178		
Mid	914.81	3kHz	178		
High	927.32	3kHz	177		

Note 1: 20dB bandwidth measured using RB = 3kHz, VB = 10kHz (VB > RB)



Analyzer Settings

Agilent Technologies, E4446A
 CF: 902.570 MHz
 SPAN: 1.000 MHz
 RB: 3.00 kHz
 VB: 10.0 kHz
 Detector: POS
 Attn: 20 DB
 RL Offset: 10.5 DB
 Sweep Time: 105.4ms
 Ref Lvl: 20.0 DBM

Comments

20dB BW: 178 kHz
 Base Low CH

Cursor 1	902.6567	11.75	Delta Freq.	178 kHz
Cursor 2	902.4783	-8.25	Delta Amplitude	20.00





EMC Test Data

Client: Pyramid Communications	Job Number: J94394
Model: WB-1000 (Wireless Basestation)	T-Log Number: T94722
	Project Manager: Christine Krebill
Contact: Chris Carbajal	Project Coordinator: -
Standard: FCC 15.247	Class: N/A

For frequency hopping systems operating in the 902-928 MHz band:
 If the 20 dB bandwidth of the hopping channel is less than 250 kHz, the system shall use at least 50 hopping frequencies and the average time of occupancy on any frequency shall not be greater than 0.4 seconds within a 20 second period.
 The channel dwell time is calculated from the transmit time on a channel multiplied by the number of times a channel could be used in the 20 second period (i.e. 20s divided by the time between successive hops, rounded up to the closest integer), unless the time between successive hops exceeds 20s in which case the channel dwell time is the transmit time on a channel.

Maximum 20dB bandwidth:	<u>178 kHz</u>	Pass	
Channel spacing:	<u>251 kHz</u>	Pass	
Transmission time per hop:	<u>9.94 ms</u>		
# of the hop:	<u>40</u>		
Number of channels (N):	<u>50</u>	Pass	Channel 1
Channel dwell time in 20 seconds:	<u>397.6 ms</u>	Pass	
Number of channels (N):	<u>50</u>	Pass	Channel 2

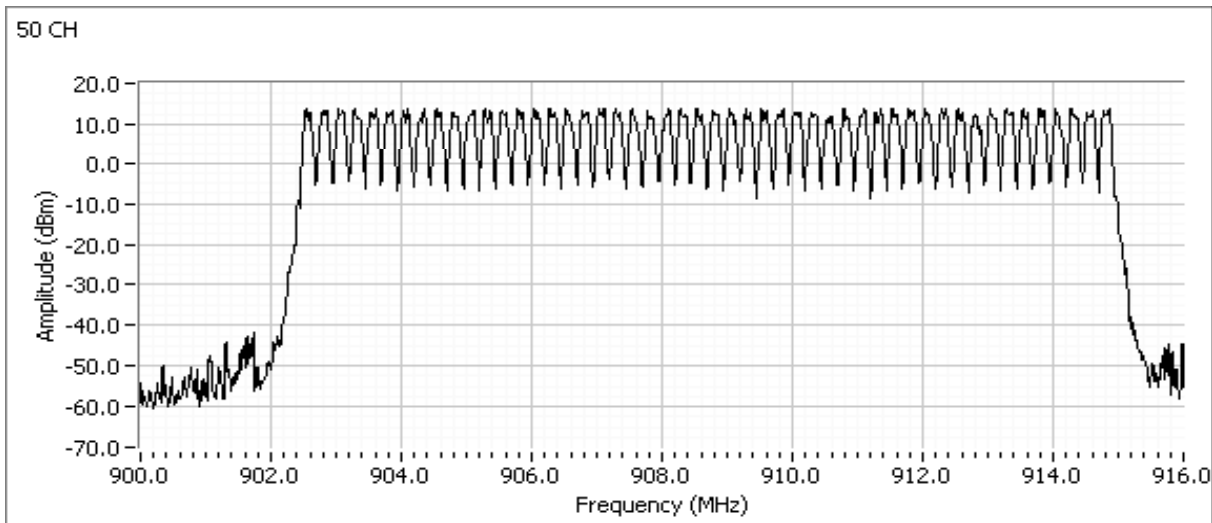



EMC Test Data

Client: Pyramid Communications	Job Number: J94394
Model: WB-1000 (Wireless Basestation)	T-Log Number: T94722
Contact: Chris Carbajal	Project Manager: Christine Krebill
Standard: FCC 15.247	Project Coordinator: -
	Class: N/A

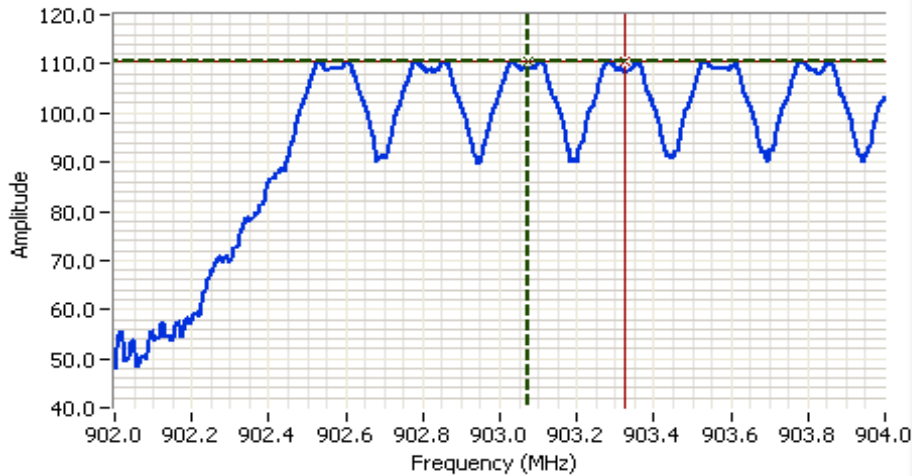

Analyzer Settings

Agilent Technologies, E4446A
 CF: 903.000 MHz
 SPAN: 2.000 MHz
 RB: 30.0 kHz
 VB: 100 kHz
 Detector: POS
 Attn: 20 DB
 RL Offset: 0.0 DB
 Sweep Time: 2.1ms
 Ref Lvl: 115.0 DBUV

Comments

Channel Spacing

Cursor 1 903.0733 110.43

Cursor 2 903.3246 110.43

Delta Freq. 251 kHz

Delta Amplitude 0.00

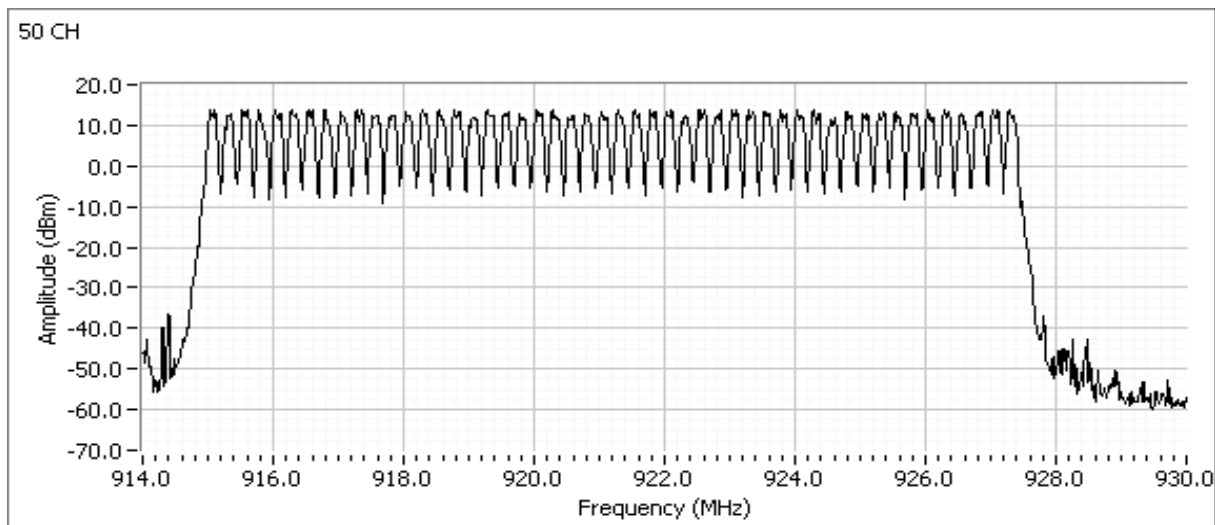



EMC Test Data

Client: Pyramid Communications	Job Number: J94394
Model: WB-1000 (Wireless Basestation)	T-Log Number: T94722
Contact: Chris Carbajal	Project Manager: Christine Krebill
Standard: FCC 15.247	Project Coordinator: -
	Class: N/A

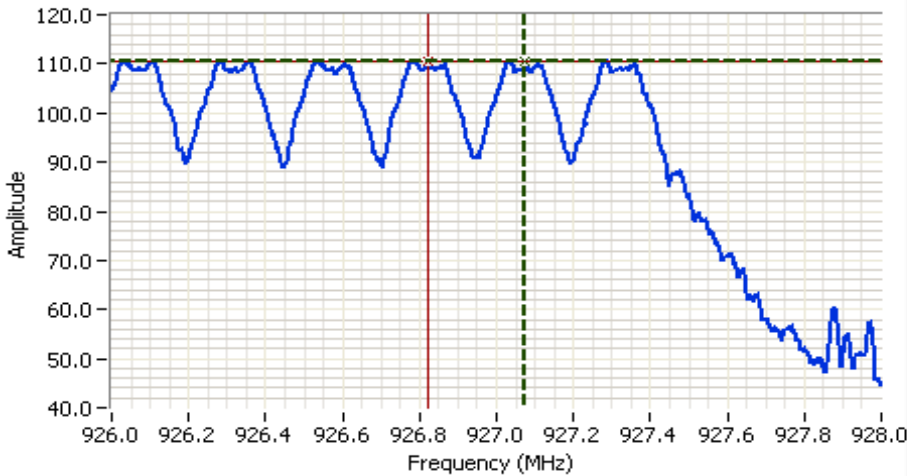

Analyzer Settings
 Agilent Technologies, E4446A
 CF: 927.000 MHz
 SPAN: 2.000 MHz
 RB: 30.0 kHz
 VB: 100 kHz
 Detector: POS
 Attn: 20 DB
 RL Offset: 0.0 DB
 Sweep Time: 2.1ms
 Ref Lvl: 115.0 DBUV

Comments
 Channel Spacing

Cursor 1 927.0733 110.4

Cursor 2 926.8220 110.4

Delta Freq. 251 kHz

Delta Amplitude 0.00

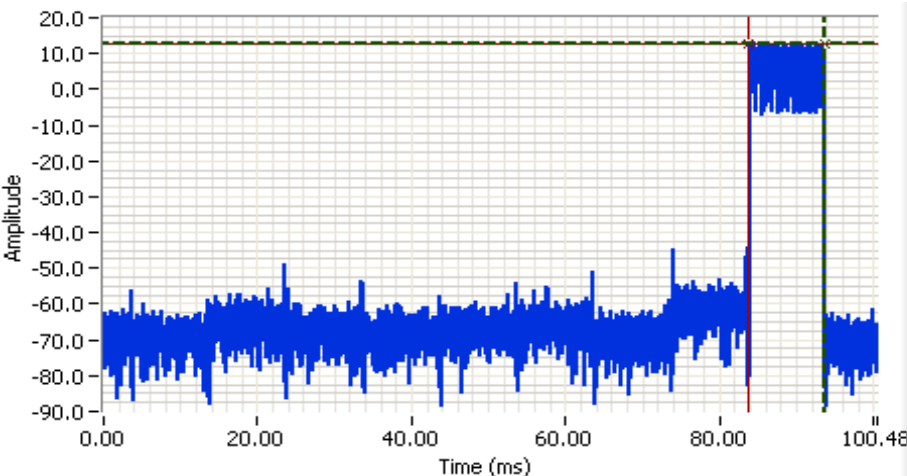

Analyzer Settings
 Agilent Technologies, E4446A
 CF: 907.570 MHz
 SPAN: 0.000 MHz
 RB: 30.0 kHz
 VB: 50.000 MHz
 Detector: POS
 Attn: 20 DB
 RL Offset: 10.5 DB
 Sweep Time: 100.5ms
 Ref Lvl: 20.0 DBM

Comments
 Hopping (Base)
 Ton=9.94ms
 Duty Cycle Correction =20dB

Cursor 1 93.6732 12.58

Cursor 2 83.7302 12.58

Delta Time (ms) 9.94

Delta Amplitude 0.00





EMC Test Data

Client: Pyramid Communications	Job Number: J94394
Model: WB-1000 (Wireless Basestation)	T-Log Number: T94722
	Project Manager: Christine Krebill
Contact: Chris Carbajal	Project Coordinator: -
Standard: FCC 15.247	Class: N/A

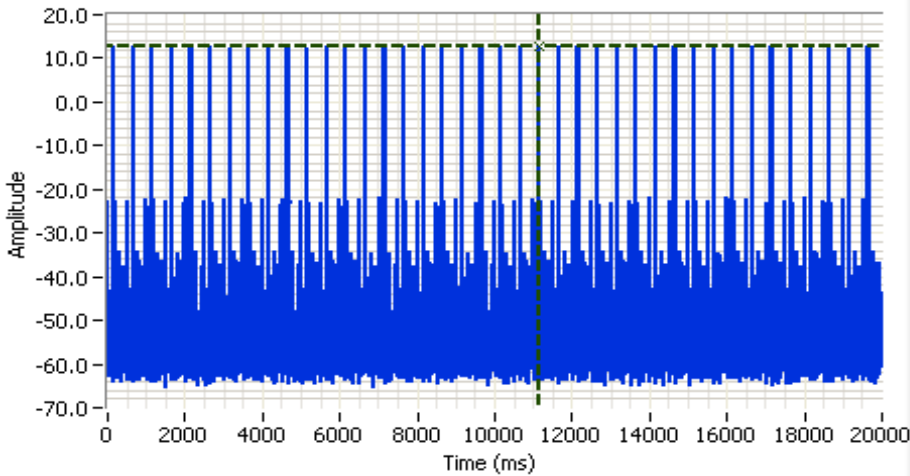

Analyzer Settings
Agilent Technologies, E4446A
CF: 907.570 MHz
SPAN: 0.000 MHz
RB: 30.0 kHz
VB: 50.000 MHz
Detector: POS
Attn: 20 DB
RL Offset: 10.5 DB
Sweep Time: 20.0s
Ref Lvl: 20.0 DBM

Comments
40hops/20s

Cursor 1 11156.2795 12.58 [Icons]
0.0000 0.00 [Icons]





EMC Test Data

Client: Pyramid Communications	Job Number: J94394
Model: WB-1000 (Wireless Basestation)	T-Log Number: T94722
	Project Manager: Christine Krebill
Contact: Chris Carbajal	Project Coordinator: -
Standard: FCC 15.247	Class: -

Conducted Emissions

(Elliott Laboratories Fremont Facility, Semi-Anechoic Chamber)

Test Specific Details

Objective: The objective of this test session is to perform final qualification testing of the EUT with respect to the specification listed above.

Date of Test: 2/24/2014	Config. Used: 2
Test Engineer: Rafael Varelas	Config Change: None
Test Location: FT Chamber #4	EUT Voltage: 120V/60Hz

General Test Configuration

For tabletop equipment, the EUT was located on a wooden table inside the semi-anechoic chamber, 40 cm from a vertical coupling plane

Ambient Conditions:	Temperature:	20.8 °C
	Rel. Humidity:	39 %

Summary of Results

Run #	Test Performed	Limit	Result	Margin
1	CE, AC Power, 120V/60Hz	15.207	Pass	55.3 dBµV @ 0.567 MHz (-0.7 dB)

Modifications Made During Testing

No modifications were made to the EUT during testing

Deviations From The Standard

No deviations were made from the requirements of the standard.

Client: Pyramid Communications	Job Number: J94394
Model: WB-1000 (Wireless Basestation)	T-Log Number: T94722
	Project Manager: Christine Krebill
Contact: Chris Carbajal	Project Coordinator: -
Standard: FCC 15.247	Class: -

Run #1: AC Power Port Conducted Emissions, 0.15 - 30MHz, 120V/60Hz
 EUT in Test Mode #1

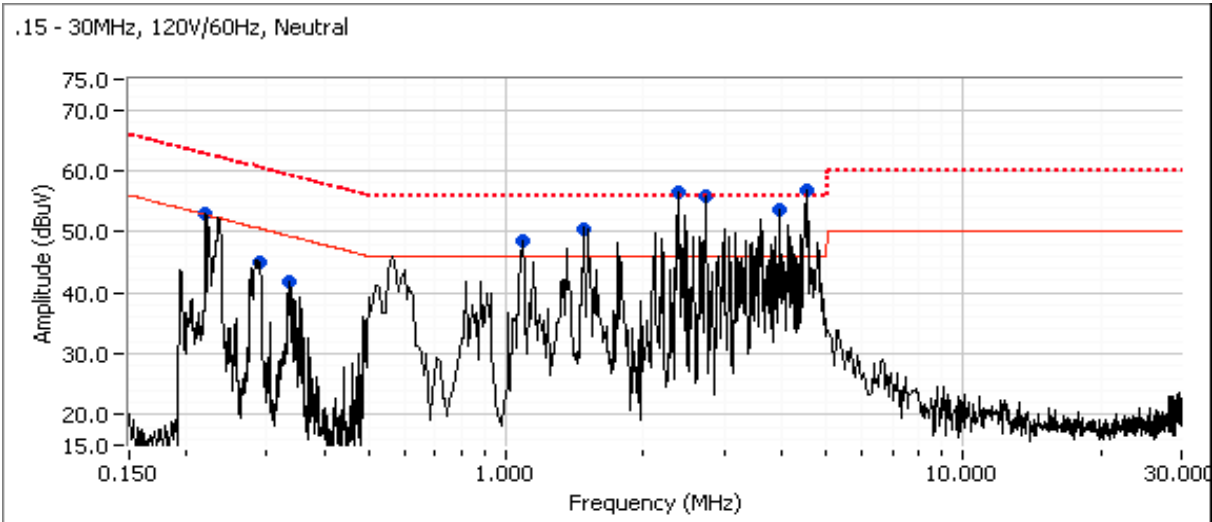
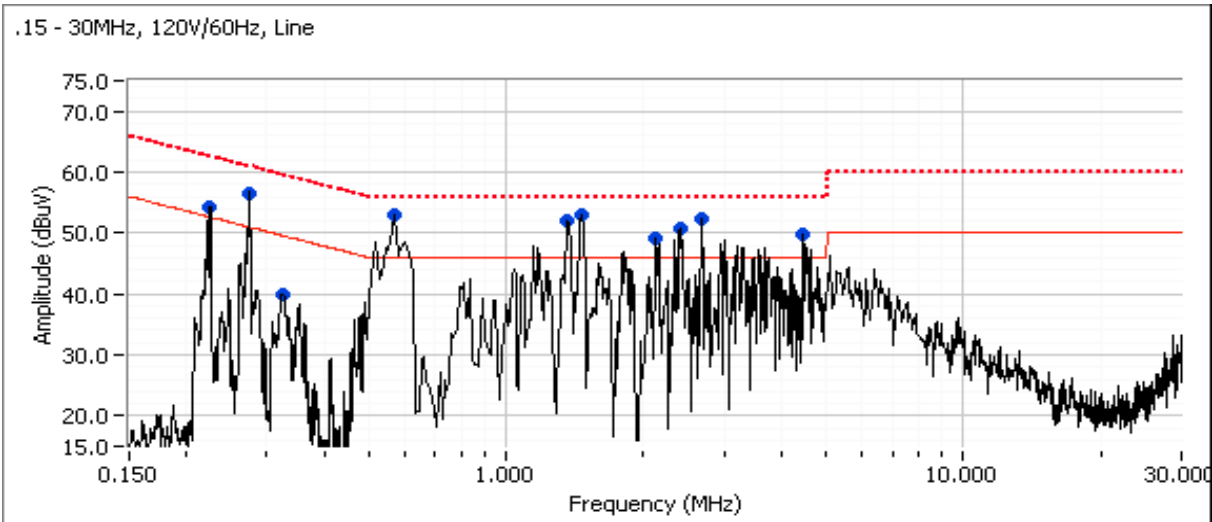



EMC Test Data

Client: Pyramid Communications	Job Number: J94394
Model: WB-1000 (Wireless Basestation)	T-Log Number: T94722
	Project Manager: Christine Krebill
Contact: Chris Carbajal	Project Coordinator: -
Standard: FCC 15.247	Class: -

Preliminary peak readings captured during pre-scan (peak readings vs. average limit)

Frequency MHz	Level dB μ V	AC Line	Class B		Detector QP/Ave	Comments
			Limit	Margin		
0.224	54.3	Line 1	52.6	1.7	Peak	
0.274	56.6	Line 1	51.0	5.6	Peak	
0.324	39.9	Line 1	49.6	-9.7	Peak	
0.567	53.1	Line 1	46.0	7.1	Peak	
1.368	51.9	Line 1	46.0	5.9	Peak	
1.464	53.0	Line 1	46.0	7.0	Peak	
2.131	49.0	Line 1	46.0	3.0	Peak	
2.413	50.8	Line 1	46.0	4.8	Peak	
2.665	52.4	Line 1	46.0	6.4	Peak	
4.463	49.7	Line 1	46.0	3.7	Peak	
0.220	53.0	Neutral	52.8	0.2	Peak	
0.288	45.1	Neutral	50.6	-5.5	Peak	
0.337	41.8	Neutral	49.3	-7.5	Peak	
1.091	48.6	Neutral	46.0	2.6	Peak	
1.469	50.3	Neutral	46.0	4.3	Peak	
2.378	56.5	Neutral	46.0	10.5	Peak	
2.724	56.0	Neutral	46.0	10.0	Peak	
3.958	53.6	Neutral	46.0	7.6	Peak	
4.536	56.8	Neutral	46.0	10.8	Peak	



EMC Test Data

Client: Pyramid Communications	Job Number: J94394
Model: WB-1000 (Wireless Basestation)	T-Log Number: T94722
	Project Manager: Christine Krebill
Contact: Chris Carbajal	Project Coordinator: -
Standard: FCC 15.247	Class: -

Final quasi-peak and average readings

Frequency MHz	Level dB μ V	AC Line	Class B		Detector QP/Ave	Comments
			Limit	Margin		
0.567	55.3	Line 1	56.0	-0.7	QP	QP (1.00s)
0.288	55.9	Neutral	60.6	-4.7	QP	QP (1.00s)
0.567	41.1	Line 1	46.0	-4.9	AVG	AVG (0.10s)
1.368	50.6	Line 1	56.0	-5.4	QP	QP (1.00s)
4.536	40.4	Neutral	46.0	-5.6	AVG	AVG (0.10s)
0.274	55.2	Line 1	61.0	-5.8	QP	QP (1.00s)
4.536	49.3	Neutral	56.0	-6.7	QP	QP (1.00s)
1.464	48.5	Line 1	56.0	-7.5	QP	QP (1.00s)
1.368	36.7	Line 1	46.0	-9.3	AVG	AVG (0.10s)
0.288	40.9	Neutral	50.6	-9.7	AVG	AVG (0.10s)
2.378	46.3	Neutral	56.0	-9.7	QP	QP (1.00s)
2.413	45.5	Line 1	56.0	-10.5	QP	QP (1.00s)
2.665	45.3	Line 1	56.0	-10.7	QP	QP (1.00s)
2.724	45.0	Neutral	56.0	-11.0	QP	QP (1.00s)
2.131	43.6	Line 1	56.0	-12.4	QP	QP (1.00s)
1.469	43.4	Neutral	56.0	-12.6	QP	QP (1.00s)
4.463	43.3	Line 1	56.0	-12.7	QP	QP (1.00s)
3.958	42.4	Neutral	56.0	-13.6	QP	QP (1.00s)
0.274	37.3	Line 1	51.0	-13.7	AVG	AVG (0.10s)
2.413	31.5	Line 1	46.0	-14.5	AVG	AVG (0.10s)
0.324	45.0	Line 1	59.6	-14.6	QP	QP (1.00s)
1.464	31.3	Line 1	46.0	-14.7	AVG	AVG (0.10s)
1.091	41.0	Neutral	56.0	-15.0	QP	QP (1.00s)
4.463	30.6	Line 1	46.0	-15.4	AVG	AVG (0.10s)
2.131	30.3	Line 1	46.0	-15.7	AVG	AVG (0.10s)
1.469	30.2	Neutral	46.0	-15.8	AVG	AVG (0.10s)
1.091	29.2	Neutral	46.0	-16.8	AVG	AVG (0.10s)
0.224	45.3	Line 1	62.7	-17.4	QP	QP (1.00s)
2.378	28.4	Neutral	46.0	-17.6	AVG	AVG (0.10s)
3.958	28.2	Neutral	46.0	-17.8	AVG	AVG (0.10s)
0.220	44.7	Neutral	62.8	-18.1	QP	QP (1.00s)
2.665	27.3	Line 1	46.0	-18.7	AVG	AVG (0.10s)
0.337	40.6	Neutral	59.3	-18.7	QP	QP (1.00s)
0.324	30.2	Line 1	49.6	-19.4	AVG	AVG (0.10s)
2.724	25.7	Neutral	46.0	-20.3	AVG	AVG (0.10s)
0.337	25.3	Neutral	49.3	-24.0	AVG	AVG (0.10s)
0.224	22.8	Line 1	52.7	-29.9	AVG	AVG (0.10s)
0.220	20.4	Neutral	52.8	-32.4	AVG	AVG (0.10s)

End of Report

This page is intentionally blank and marks the last page of this test report.