

# Form References

## 1. Name of Applicant:

Pyramid Communications  
15182 Triton Lane, Suite #102  
Huntington Beach, CA 92649

## 2. Identification of equipment:

LRUSVR-200U  
UHF Transceiver

## 3. Production Planned

Normal mass production, 500pcs / lot

## 4. Technical Description

- a. Types of emission
  - i. 11K0F3E
  - ii. 16K0F3E
- b. Frequency Range
  - i. 400-512 MHz
- c. Range of operation power
  - i. 0.25 – 2.0 watts continuously variable
- d. Maximum power output
  - i. 2 Watts
- e. DC voltage and current to final RF amplifier
  - i. 9.0 VDC @ 1A

# RF Power Output/Frequency Exhibit F

## Minimum Standard

Power: 2 Watts minimum  
Frequency Tolerance:  $\pm 1.5$  ppm maximum

## Measurements

Power: 2.15 Watts  
Frequency: 460.612590  
Error  $+2$  ppm

To the best of my knowledge,  
This data is accurate.

Signed:



Date: **20-Dec-2010**

# Modulation Characteristics

## Exhibit F

Frequency response of the audio modulation circuits: The SVR-200 and 250 units are designed to interface to a variety of mobile radios. The receiver audio that is available may or may not be de-emphasized. Therefore, PC programming provides for flat audio response, or +6db/octave pre-emphasis. Both responses were measured and plotted.

Frequency	Flat	+6db/octave pre-emphasis
200	-8	-22
300	0	-11
400	+.3	-7.5
500	+.5	-6
1000	0	0
1500	-.25	+2.5
2000	-.5	+4.5
2500	-.75	+6
3000	-1.75	+6
3500	-5	+3
4000	-12	-1
4500	-20	-9
5000	-26	-15

To the best of my knowledge,  
This data is accurate.

Signed:



Date: 20-Dec-2010

# Transmit Audio Response Exhibit F

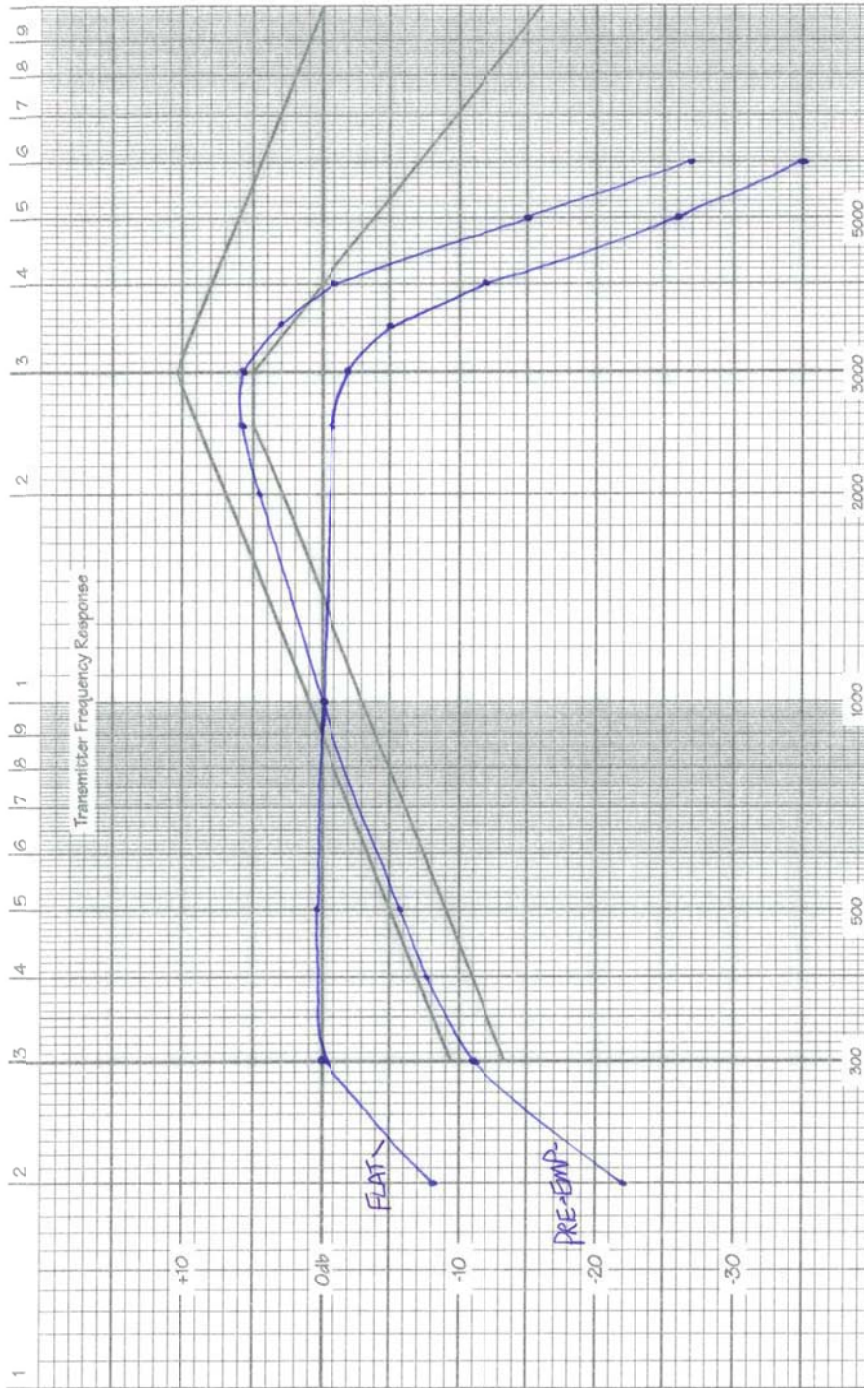

# Audio Lowpass Filter Response Exhibit F

Frequency	Response	
1000	0 dB	
2000	-.46	
3000	-.2.6	
4000	-10.3	
5000	-26.7	
6000	-45.6	
7000	-52.7	
8000	-52.7	{Noise Floor}
9000	-52.7	
10000	-52.7	
12000	-52.7	
14000	-52.7	
16000	-52.7	
18000	-52.7	
20000	-52.7	

To the best of my knowledge,  
This data is accurate.

Signed:



Date: **20-Dec-2010**

# Modulation Characteristics

## Limiter Response: 5 kHz Max Deviation

### Exhibit F

Input Level	2.5 kHz	1.0 kHz	300 Hz
0 dB	± 1.60 kHz	± 1.60 kHz	± 1.60 kHz
2	1.89	1.96	2.07
4	2.23	2.43	2.53
6	2.72	3.08	3.16
8	3.14	3.71	3.91
10	3.29	3.99	4.18
12	3.36	4.13	4.28
14	3.44	4.23	4.36
16	3.47	4.34	4.47
18	3.50	4.36	4.54
20	3.53	4.38	4.63
22	3.54	4.42	4.78
24	3.56	4.43	4.83
26	3.57	4.36	4.81
28	3.57	4.28	4.78
30	3.57	4.29	4.81

To the best of my knowledge,  
This data is accurate.

Signed:



Date: **20-Dec-2010**

# Modulation Characteristics

## Limiter Response: 2.5 kHz Max Deviation

### Exhibit F

Input Level	2.5 kHz	1.0 kHz	300 Hz
0 dB	± 825 Hz	± 825 Hz	± 825 Hz
2	1000	1000	1000
4	1200	1300	1300
6	1400	1625	1550
8	1500	2050	2000
10	1550	2200	2300
12	1600	2250	2350
14	1600	2400	2425
16	1600	2450	2480
18	1600	2450	2500
20	1600	2450	2500
22	1600	2450	2500
24	1600	2450	2500
26	1600	2450	2500
28	1600	2450	2500
30	1600	2450	2500

To the best of my knowledge,  
This data is accurate.

Signed:



Date: **20-Dec-2010**

# Occupied Bandwidth 25 kHz Channel Spacing Exhibit F

Emission 16K0F3E

The SVR-200 and SVR-250 transmits voice and single tone frequencies in the 300-3000 bandwidth. Emissions are amplitude limited and band limited by highpass and lowpass filters per the previous sections. The following plot was made with a 2.5 kHz tone at 16dB above 50% level for 1 kHz (per EIA-152C)

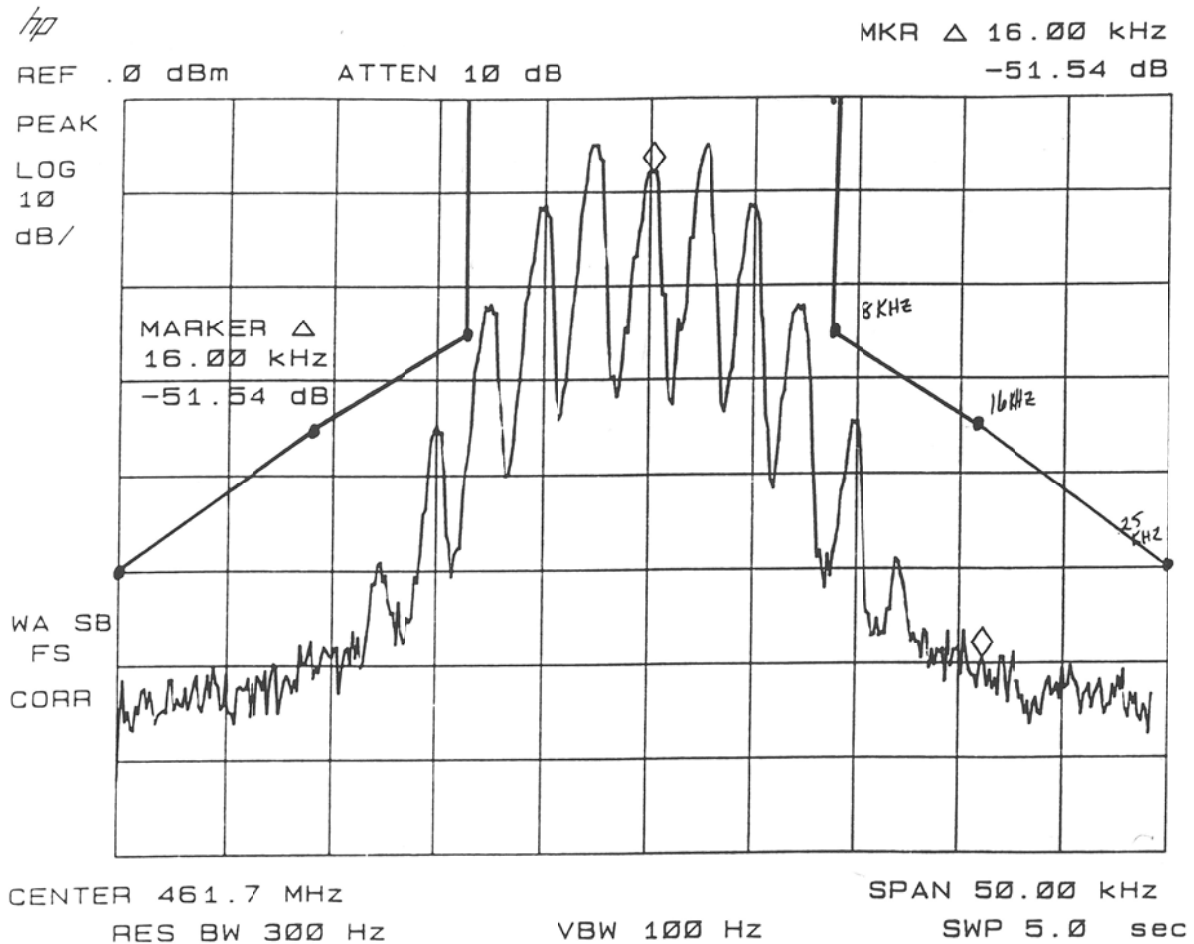

To the best of my knowledge,  
This data is accurate.

Signed:

*William G. Gelin*

Date: 20-Dec-2010



# Occupied Bandwidth 12.5 kHz Channel Spacing Exhibit F

Emission 11K0F3E

The SVR-200 and SVR-250 transmits voice and single tone frequencies in the 300-3000 bandwidth. Emissions are amplitude limited and band limited by highpass and lowpass filters per the previous sections. The following plot was made with a 2.5 kHz tone at 16dB above 50% level for 1 kHz (per EIA-152C)

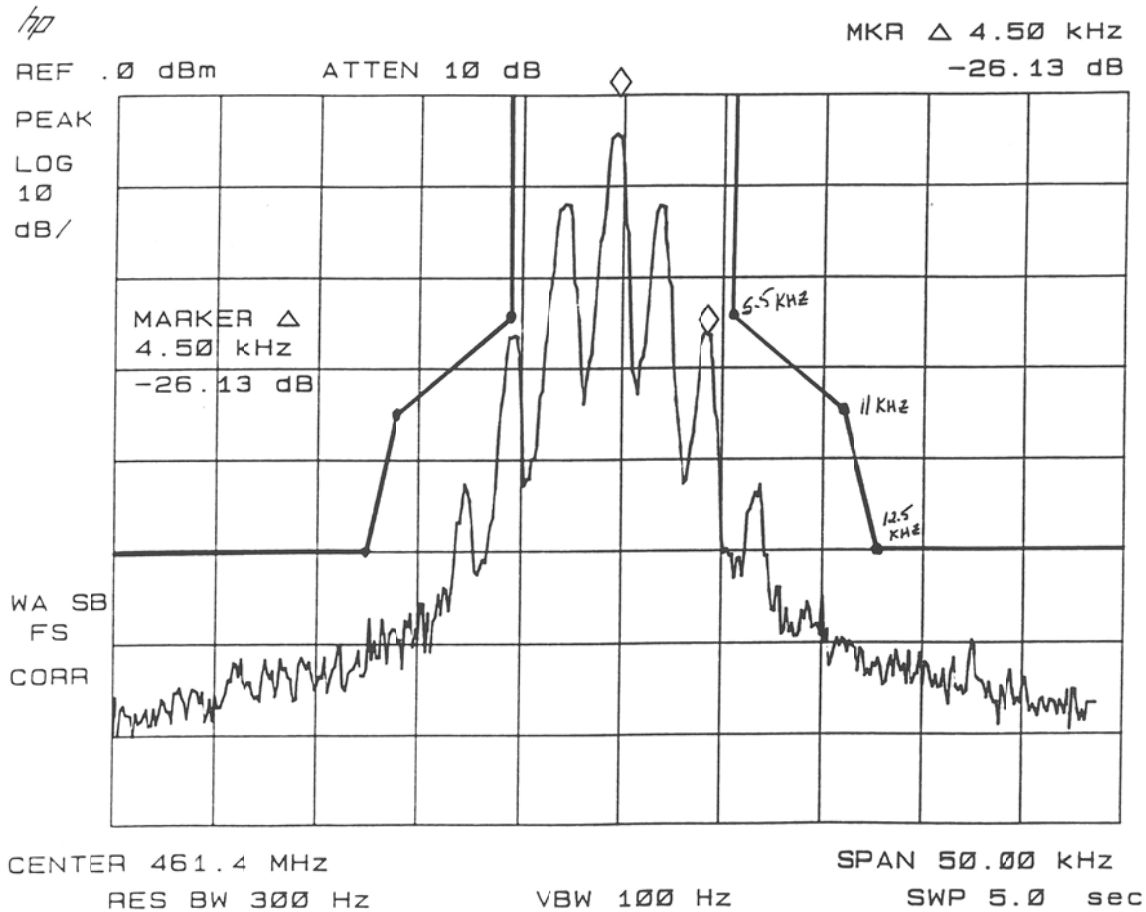

To the best of my knowledge,  
This data is accurate.

Signed:

*William G. Gelin*

Date: 20-Dec-2010

# Spurious emissions at the antenna terminal

## Exhibit F

### Minimum Standard

-43 dbc

### Measurements

Power: 2.0 Watts

Frequency	Level	
455.1000 MHz	0	
910.2000	-52.60 dbc	2 <sup>nd</sup> Harmonic
1365.300	< -65 dbc	3 <sup>rd</sup> Harmonic

To the best of my knowledge,  
This data is accurate.

Signed:



Date: **20-Dec-2010**

# Conducted Spurious: 2 Watts Exhibit F

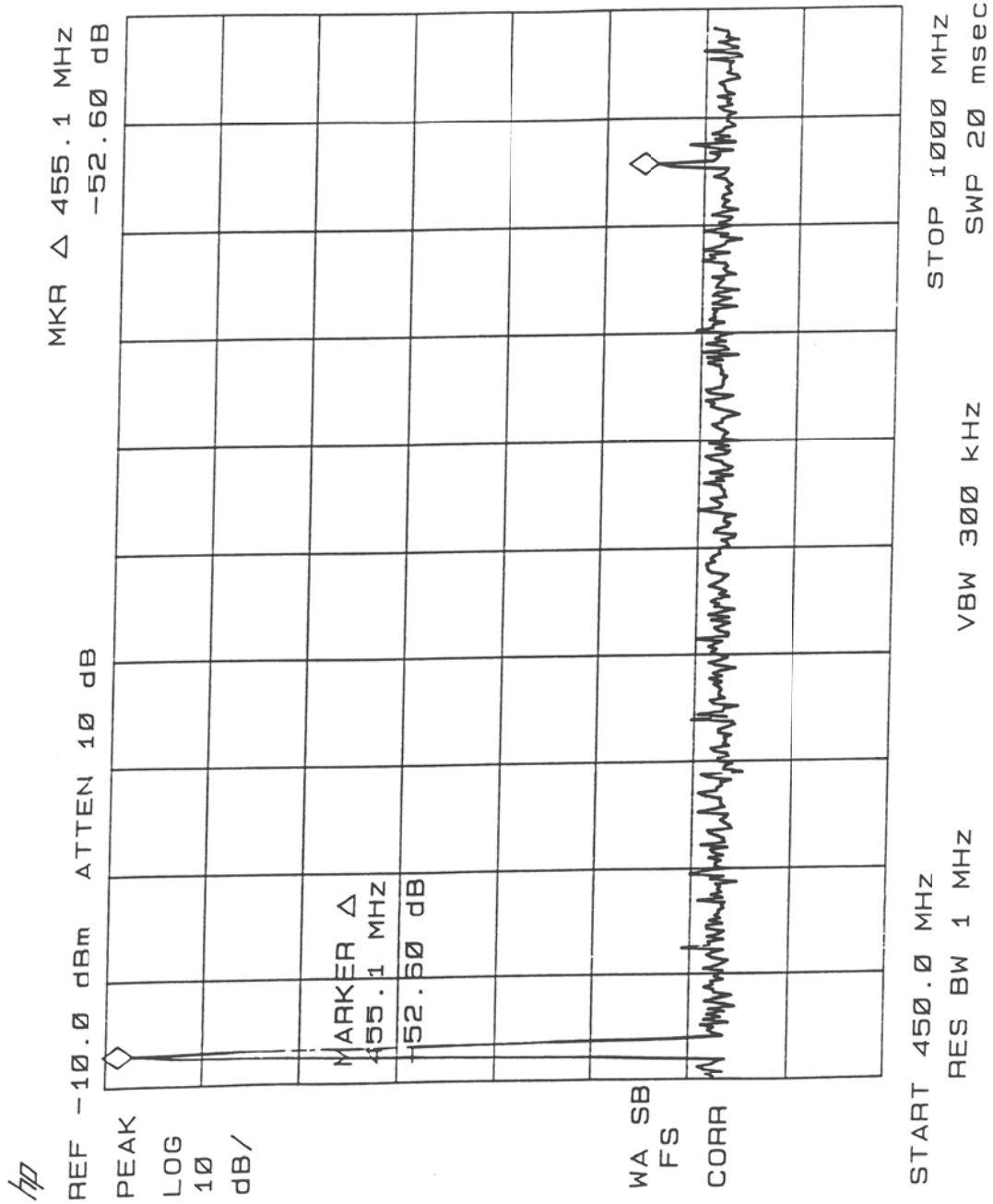

To the best of my knowledge,  
This data is accurate.

Signed:

*William G. G. G.*

Date: 20-Dec-2010

# Spurious emissions at the antenna terminal

## Exhibit F

### Minimum Standard

-33 dbc

### Measurements

Power: 0.25 Watts

Frequency	Level
466.5000 MHz	0
933.0000	< -60 dbc 2 <sup>nd</sup> harmonic
1399.500	< -60 dbc 3 <sup>rd</sup> harmonic

To the best of my knowledge,  
This data is accurate.

Signed:



Date: **20-Dec-2010**

# Conducted Spurious: 0.25 Watt Exhibit F

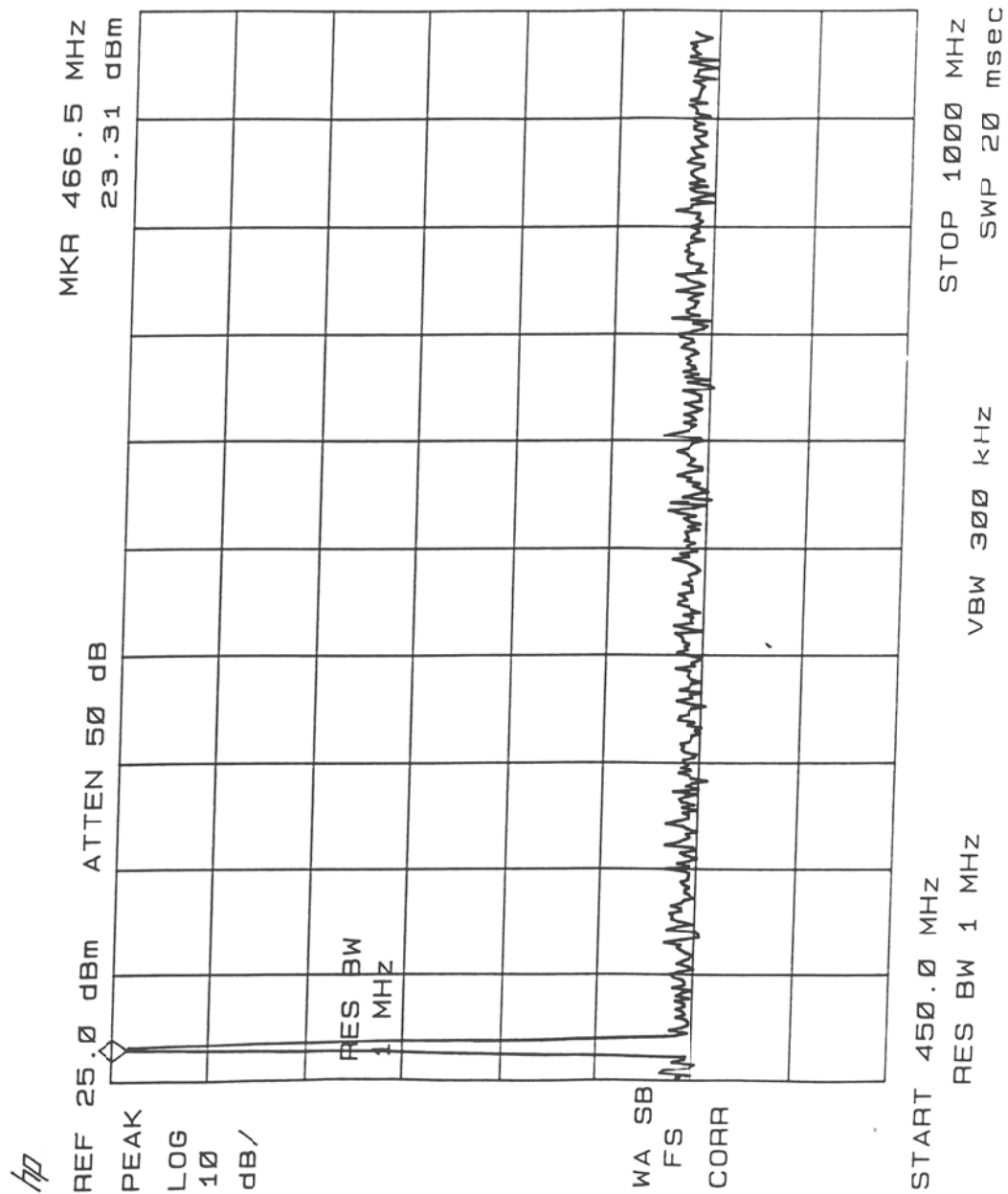

To the best of my knowledge,  
This data is accurate.

Signed:

*William G. Gelin*

Date: 20-Dec-2010

#

# Frequency Stability Exhibit F

## Minimum Standard

$\pm 1.5$  ppm ( $\pm 1290$  Hz)

### a. Frequency Stability Over Temperature

Temp (°C)	Frequency	Error
-30	460.613100	+1.3 ppm
-20	460.613010	+1.1 ppm
-10	460.612825	+0.7 ppm
0	460.612640	+0.3 ppm
+10	460.612550	+0.01 ppm
+20	460.612500	+0.0 ppm
+30	460.612410	-0.2 ppm
+40	460.612460	-0.1 ppm
+50	460.612540	+0.1 ppm
+60	460.612850	+0.8 ppm

To the best of my knowledge,  
This data is accurate.

Signed:



Date: **20-Dec-2010**

# Frequency Stability Exhibit F

## Minimum Standard

± 5 ppm

### b. Frequency stability with variation in primary supply voltage

Voltage	% Standard	Frequency	% Error
11.56	-15%	460.612590	+ .2 ppm
12.24	-10%	460.612590	+ .2 ppm
12.92	-5%	460.612590	+ .2 ppm
13.60	0	460.612590	+ .2 ppm
14.28	+5%	460.612590	+ .2 ppm
14.96	+10%	460.612590	+ .2 ppm
15.64	+15%	460.612590	+ .2 ppm

To the best of my knowledge,  
This data is accurate.

Signed:



Date: **20-Dec-2010**

# Transient Frequency Behavior Exhibit F

Minimum Standard	16K0F3E	11K0F3E
T1 10mS	± 25 kHz	± 12.5 kHz
T2 25mS	± 12.5 kHz	± 6.25 kHz
T3 10mS	± 25 kHz	± 12.5 kHz

## Transient Frequency Response

T1 10mS	within + 5 kHz
T2 20mS	within FCC limits per Part 90.214
T3 1.8mS	within ± 12.5 kHz

To the best of my knowledge,  
This data is accurate.

Signed:



Date: **20-Dec-2010**





# Transient Frequency Response T3 Exhibit F

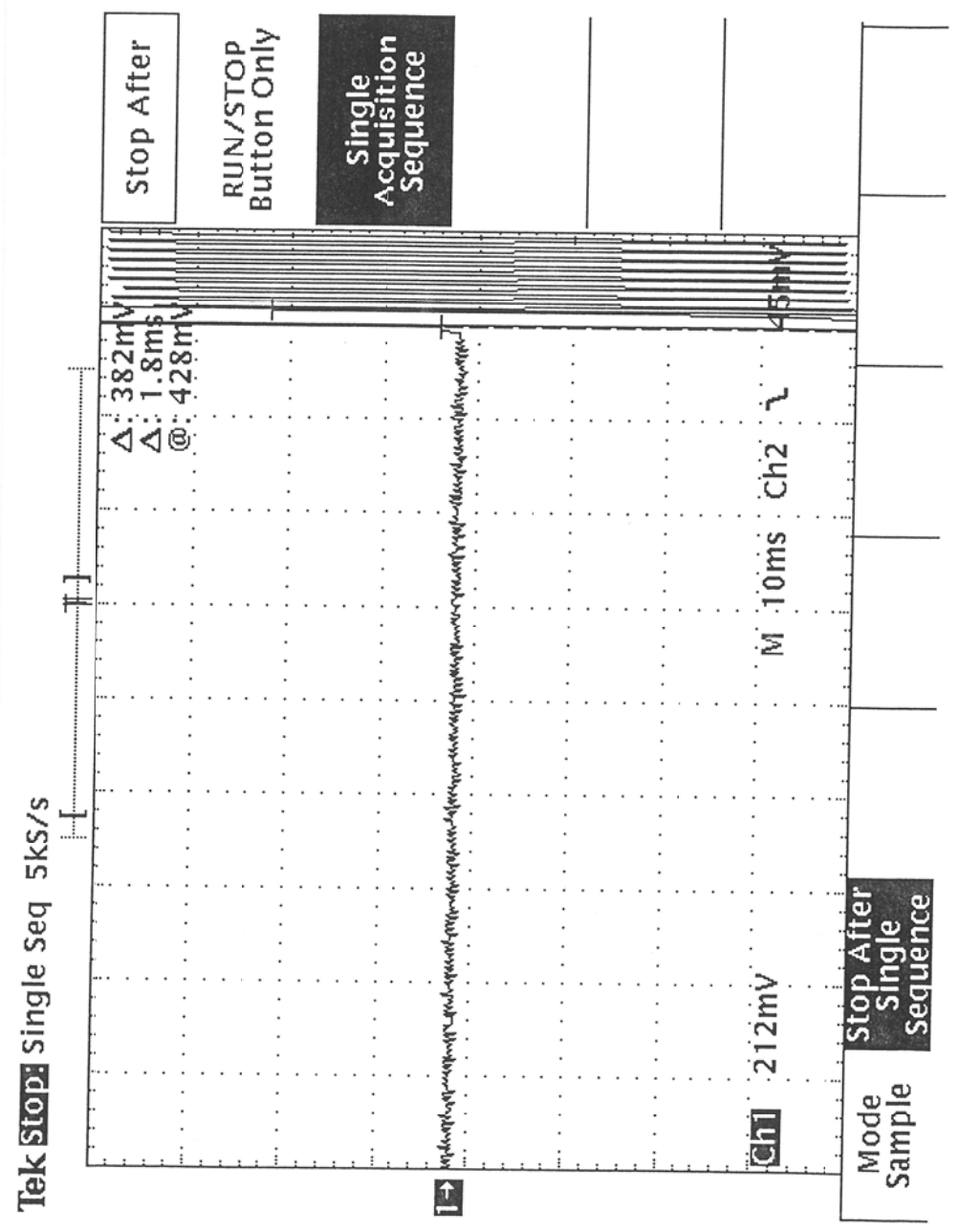

To the best of my knowledge,  
This data is accurate.

Signed:

Date: 20-Dec-2010

## Test Location

The included tests were performed at:

Pyramid Communications  
 15182 Triton Lane, Suite 102  
 Huntington Beach, CA 92649  
 By: William Carlin

The Pyramid Communications facility is a state of the art engineering office where all of the products that Pyramid Communications are designed and produced. Since 1990, Pyramid Communications has used this facility for both engineering and testing of its products. Our experience with compliance testing of our products goes back to the original part 90 testing of the model VR-100 in the early 90's and the SVR family of vehicle repeater in subsequent years. In the past, we perform the majority of FCC part 90 testing at our facility with the equipment listed below.

\* A list of test equipment and measurements is listed below

Manufacturers	Description	Model Number	Serial Number	Calibration Dates
GW Instek	Power Supply	GPS3303	EE841018	N/A
Tektronics	Oscilloscope	TDS-340	B040703	N/A
HP	Frequency Counter	8920	3352A03786	7/5/2010
Fluke	Digital Multi Meter	Model 89	84740422	N/A
IFR	Audio Source	1200S	15112	8/4/2010
IFR	Modulation Analyzer	1200S	12112	8/4/2010
HP	Plotter	7475A	N/A	N/A
HP	Spectrum Analyzer	8590A	2913A00128	4/14/2010
Tenney Jr.	Climate Chamber	Jr.	N/A	N/A
Watlow	Digital Temp Controller	942	N/A	N/A
JFW	RX Coax Attenuator	50FH-030-50	N/A	N/A
HP	Audio Analyzer	8920	3352A03786	7/5/2010
IFR	RF Test Receiver	1200S	15112	8/4/2010
IFR	RF Signal Generator	1200S	15112	8/4/2010
JFW	RF Peak Detector	50D-003-B	N/A	N/A
JFW	RF Combiner	50PD-001	N/A	N/A
Aeroflex	Freq Counter/Pwr Meter/Audio Analyzer	2975	598002G23	3/6/2010

# Measurement Procedure

## Exhibit G

Subpart 2.985 (a)  
RF Power Out/Frequency

Test Set up

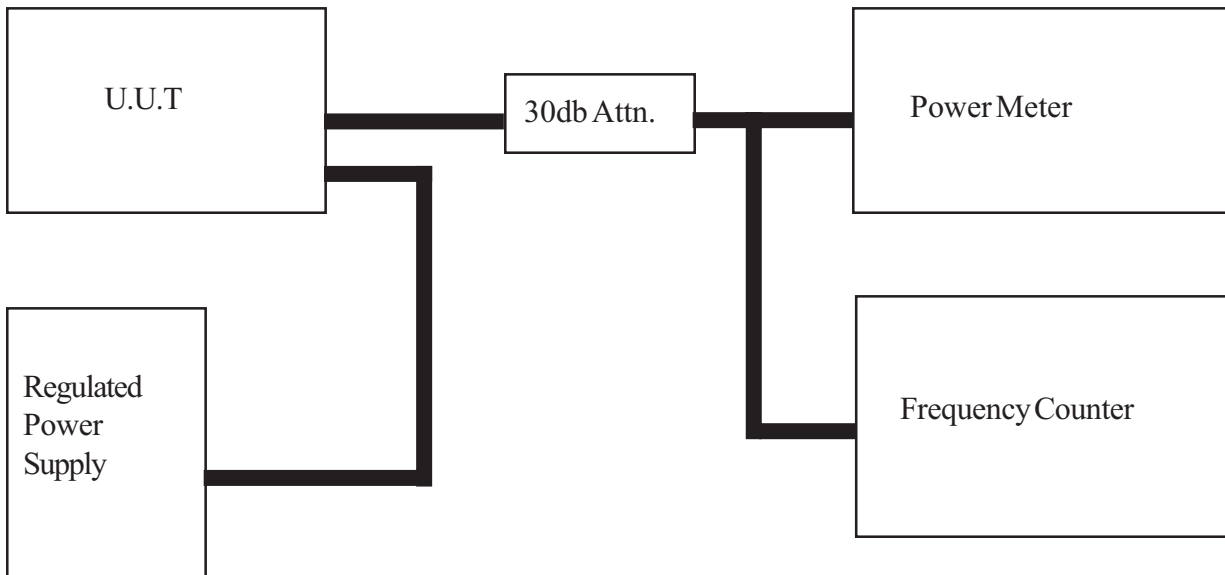

### Procedure:

Power supply is set to operating voltage and the unit under test is put into the transmit mode; RF power is read directly on the RF power meter. Frequency may also be read directly connected to the same point.

# Measurement Procedure

## Exhibit G

Subpart 2.987 (a)  
Modulation Characteristics

Audio Low Pass filter response

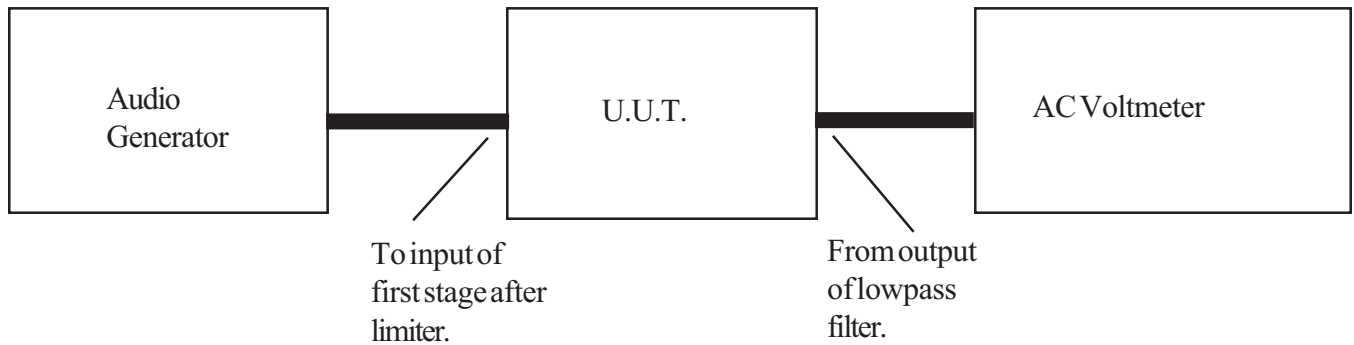

### Procedure:

An audio generator is connected to the lowpass filter input just after the limiter circuit, and the AC voltmeter is connected to the lowpass filter output, before the modulator. The audio generator is varied between 1000Hz and 20,000 Hz with it's level held constant while the level of the filter is recorded.

# Measurement Procedure

## Exhibit G

Subpart 2.987 (a)  
Modulation Characteristics

Modulation frequency response

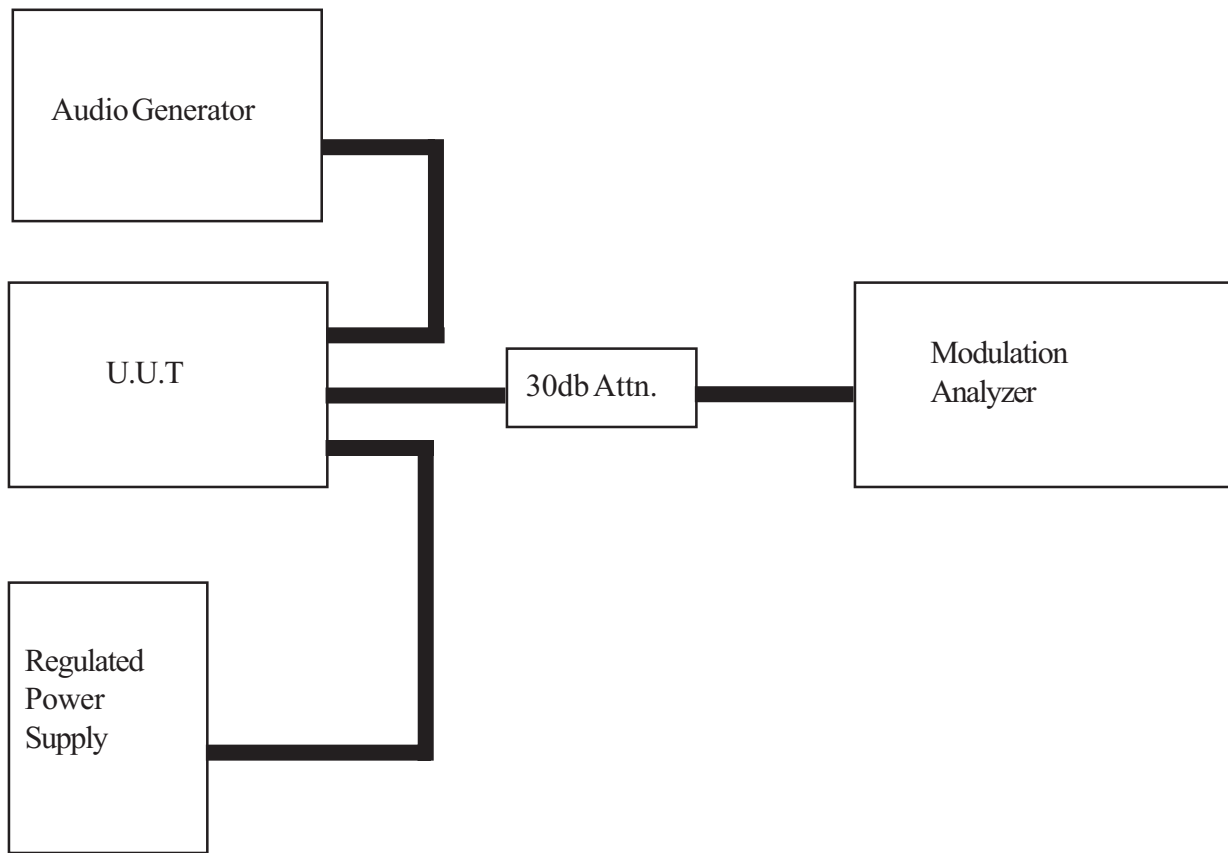

### Procedure:

Adjust the audio input level at 1kHz to produce 30% of system deviation. Change the frequency of the audio generator and record the change in level needed to maintain 30% deviation.

# Measurement Procedure

## Exhibit G

Subpart 2.987 (b)  
Modulation Characteristics

Limiter response

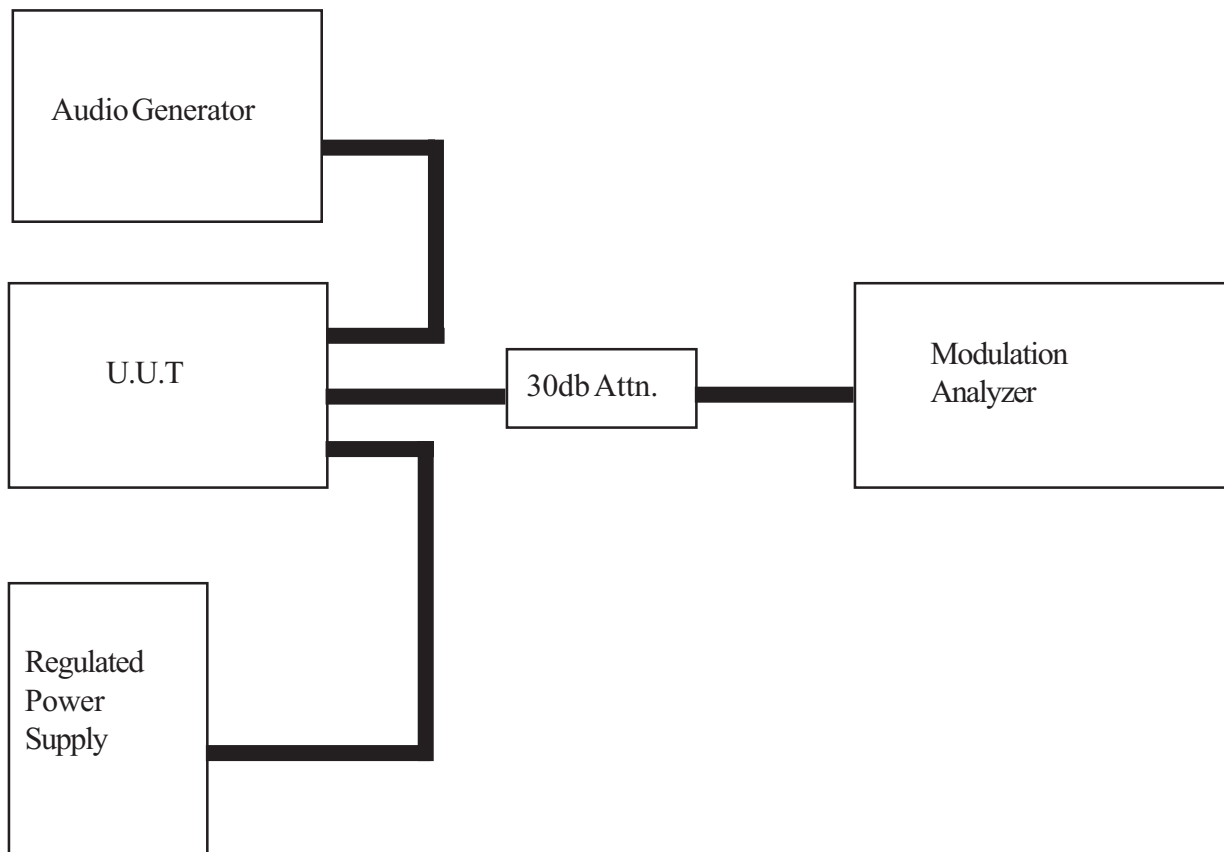

### Procedure:

The audio generator is adjusted for 33% of rated system deviation at 2500 Hz frequency. This level will be the 0db reference. The audio level is then increased from 0db to 30db in 2db increments and the level of modulation is recorded. The measurement procedure is then repeated for 1000 Hz and 300 Hz.

# Measurement Procedure

## Exhibit G

Subpart 2.989 (c)(1)  
Occupied Bandwidth

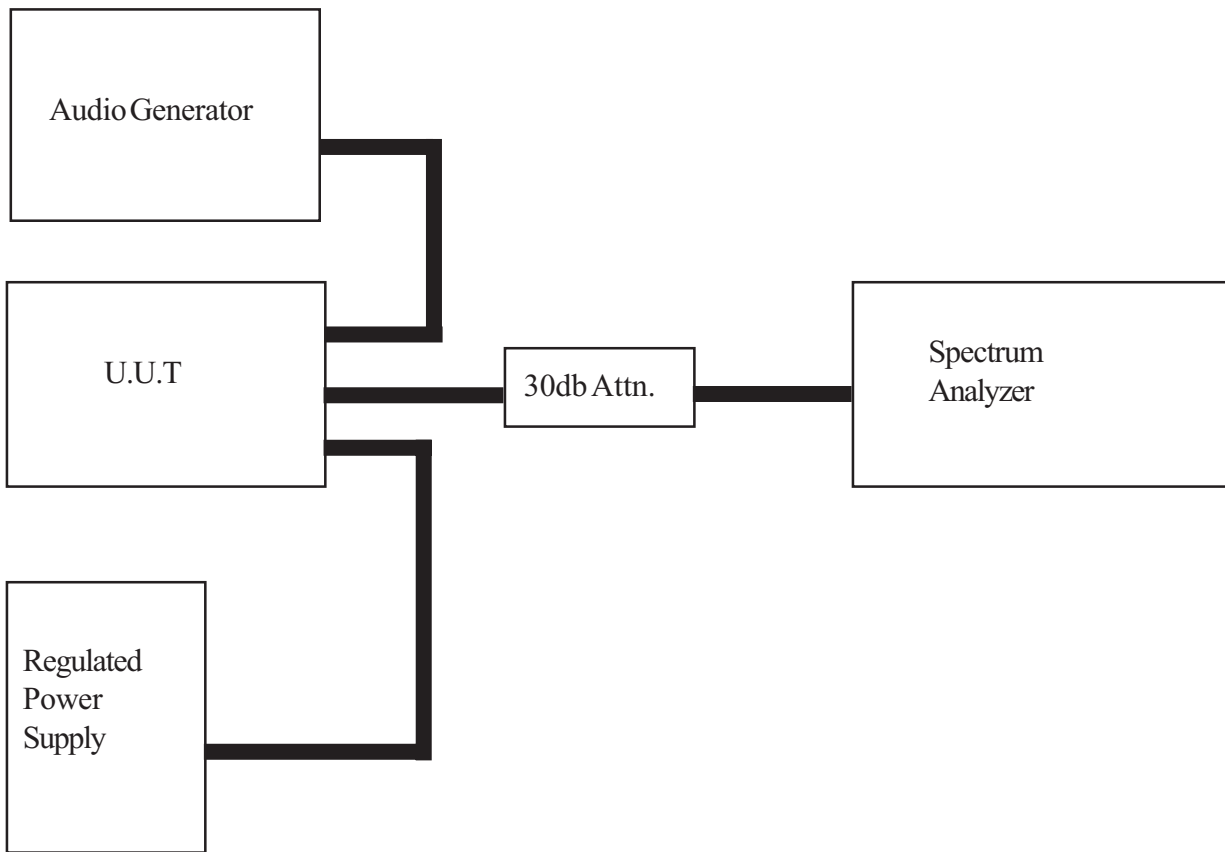

### Procedure:

The spectrum analyzer center frequency is set to the transmit frequency and the span is set to twice the authorized channel spacing. The resolution and video bandwidth are adjusted for proper response to the system deviation and modulating frequency. The audio generator is set on the frequency of maximum audio response and its level adjusted for 50% system deviation, then increased by 16db. The audio frequency is then changed to 2500 Hz and the occupied bandwidth is recorded from the spectrum analyzer.



# Measurement Procedure

## Exhibit G

Subpart 2.991  
Conducted spurious emissions at the antenna terminals

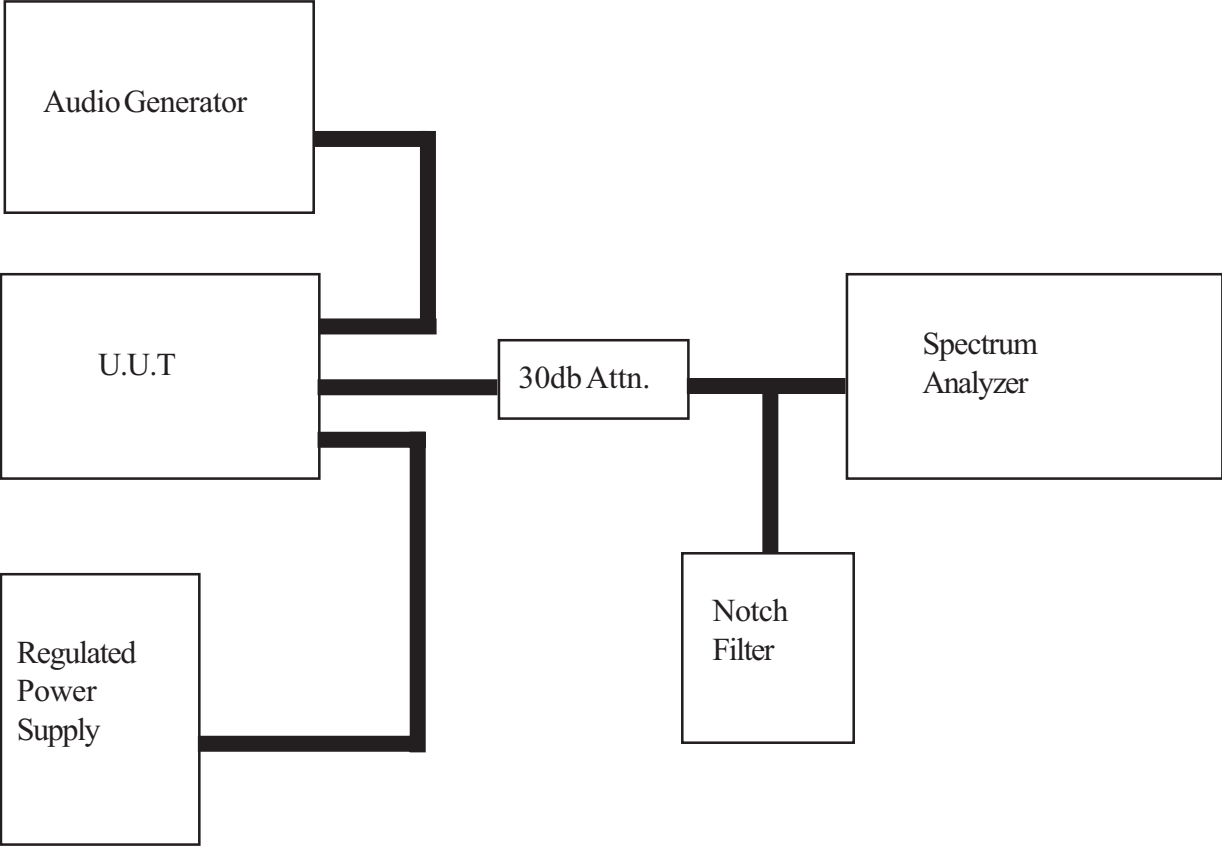

### Procedure:

The radio is set up as in Subpart 2.989 and all spurious levels and harmonics recorded using the spectrum analyzer.

# Measurement Procedure

## Exhibit G

Subpart 2.995 (a)(b)  
Frequency stability with variation of ambient temperature

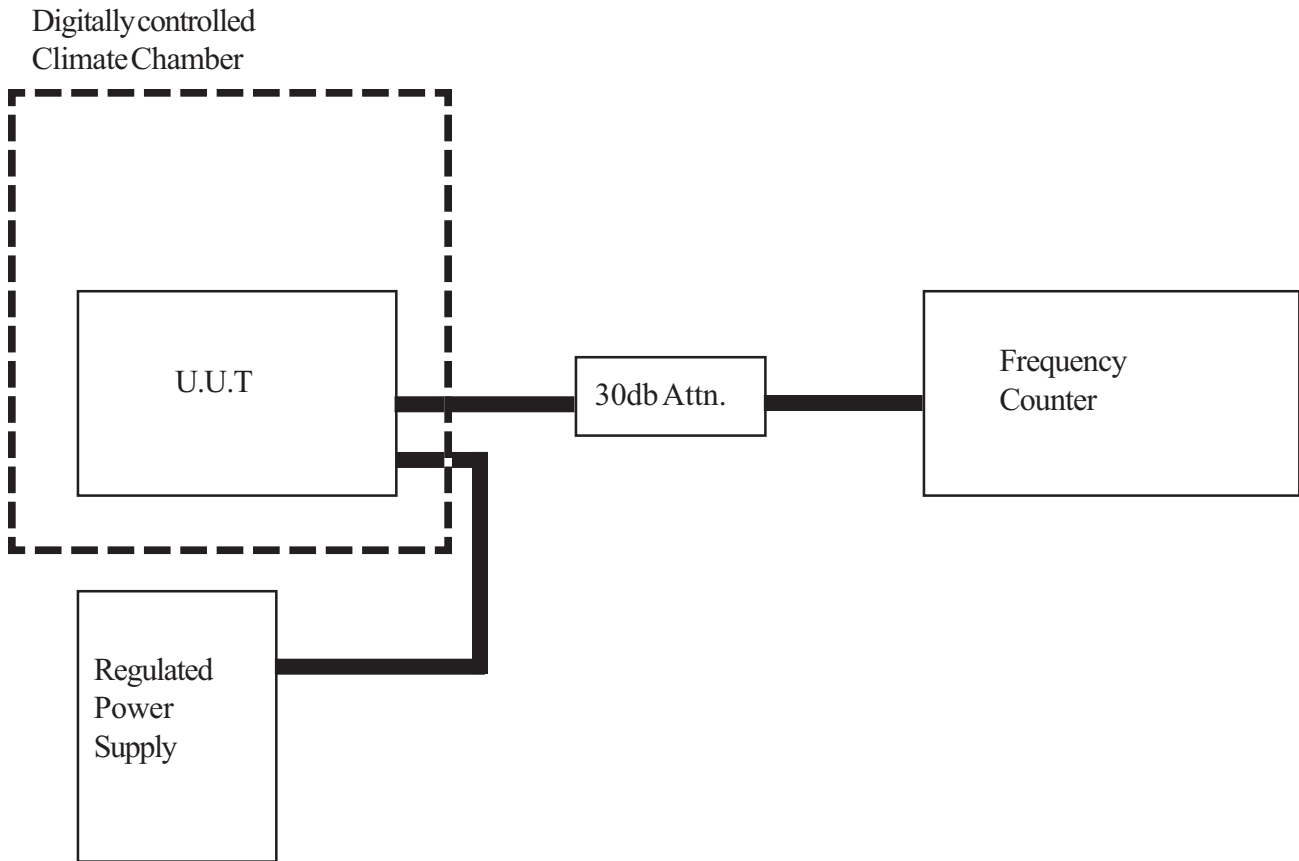

### Procedure:

The radio is brought up to +50°C allowing two hours for the radio to stabilize after the chamber reaches temperature. Power is applied and the frequency is immediately read. Power is then removed and the climate chamber lowered by 10°C allowing 30 minutes for the radio to stabilize after the chamber reaches temperature. The power is applied again, and another frequency reading is taken immediately. This process continues down to -30°C.

# Measurement Procedure

## Exhibit G

Subpart 2.995 (d)  
Frequency stability with variation of primary supply voltage.

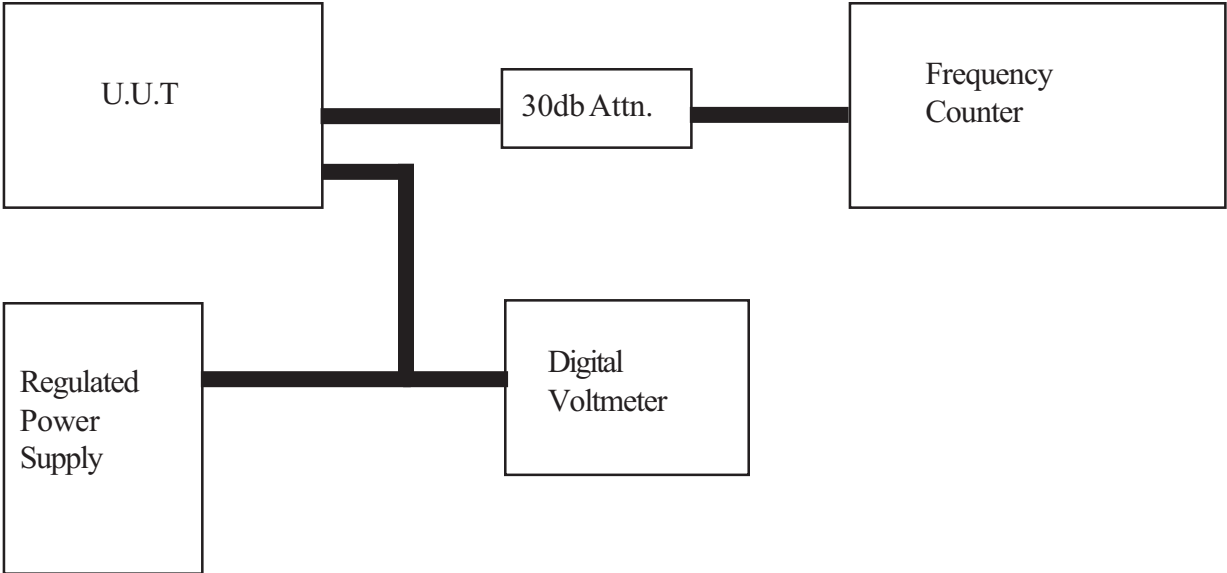

### Procedure:

The primary supply voltage is varied in steps of 5% from +15% to -15% of normal operating voltage. The frequency is recorded at each 5% step.