

## ***Alignment and Tuning Procedure***

Note: See Adjustment and Test point locations on page A7.

Connect the test equipment as shown in Figure 1 on page A6.

### **SVR-200 Transmitter**

1. ***Transmitter Output:*** Short J3 and adjust RV10 for desired power out.
2. ***Transmitter frequency:*** Adjust the TCXO on the RF board for the transmit frequency  $\pm 100$  Hz.
3. ***Maximum deviation/lock tone deviation:*** Adjust RV7 (lock tone deviation) for maximum. If the SVR-200 is programmed for sub-audible encode, adjust RV6 (CTCSS) for the off position. Adjust RV8 (repeater deviation) for 95% of system deviation. Adjust RV7 for 60% deviation. Remove J3.
4. ***Mobile COR:*** Measure the voltage at pin 7 of SVR-200 main connector P1 and record. Set the mobile service monitor for the mobile receive frequency, 1mV RF output and CTCSS modulation of 15%. Measure the voltage again at pin 7 and record. Turn the mobile service monitor off and adjust RV1 on the SVR-200 main board for the halfway point between the two voltage readings as read at pin 2 of U1.
5. ***RX audio sensitivity/CTCSS deviation:*** Set the service monitor connected to the mobile for the mobile receive frequency and 1mV RF output. Modulate the signal generator with a 1kHz tone at 60% deviation and CTCSS tone at 15% deviation. Ensure that the SVR-200 mobile COR and repeater PTT LED's are on. Adjust RV5 on the SVR-200 main board for 60% deviation as read on the service monitor connected to the SVR-200. If programmed for sub-audible encode, remove the 1kHz tone deviation from the mobile service monitor and adjust RV6 on the SVR-200 main board for 15% deviation. Turn the RF output from them mobile service monitor off and ensure that the SVR-200 mobile COR and repeater PTT LED's are off.
6. ***Local mic repeat:*** If the SVR-200 is programmed for local mic repeat, key the mobile local mic and inject an audio signal into the local mic to produce 60% deviation on the service monitor connected to the mobile. Confirm that the SVR-200 repeater PTT LED is on; adjust RV2 for 60% deviation as read on the service monitor connected to the SVR-200. Unkey the mobile radio.

## Exhibit A

**Receiver**

1. **Receiver front end:** Connect a DC voltmeter to TP1 on the SVR-200 main board. Set the service monitor connected to the SVR-200 to the generate mode, receive frequency with a 1kHz tone and 60% deviation. Adjust the RF output of the monitor for a 1VDC reading at TP1. Adjust L14 and L4 on the RF board for a maximum reading at TP1; adjust the RF output of the monitor accordingly to maintain an approximate reading of 1VDC at TP1.
2. **Dicrimminator:** Increase the service monitor RF output for 1mV. Connect a DC voltmeter to pin 13 of P2 and adjust L1 for 1.75 VDC  $\pm$ 25mV.
3. **Repeater squelch:** Adjust the service monitor RF output for .5 $\mu$ V. Adjust RV9 on the SVR-200 main board so the repeater COR LED is just on. Decrease the service monitor RF output to .35 $\mu$ V and ensure that the repeater COR LED is off.
4. **Transmit audio output:** Adjust the service monitor RF output for 1mV. Turn the CTCSS modulation on and set for 15% deviation. Confirm that the repeater COR, CTCSS and mobile PTT LED's are on. Adjust RV3 on the SVR-200 main board for 60% deviation as read on the service monitor connected to the mobile radio.
5. **Local Rx audio:** Connect an 8 ohm speaker to P4 and set RV4 for the desired listening level. Turn off the CTCSS modulation of the service monitor connected to the SVR-200. Confirm that the repeater CTCSS and mobile PTT LED's are off.
6. Change the 1kHz tone modulation to the lock tone frequency. Confirm that the PRI LED goes off after approximately .5 seconds.

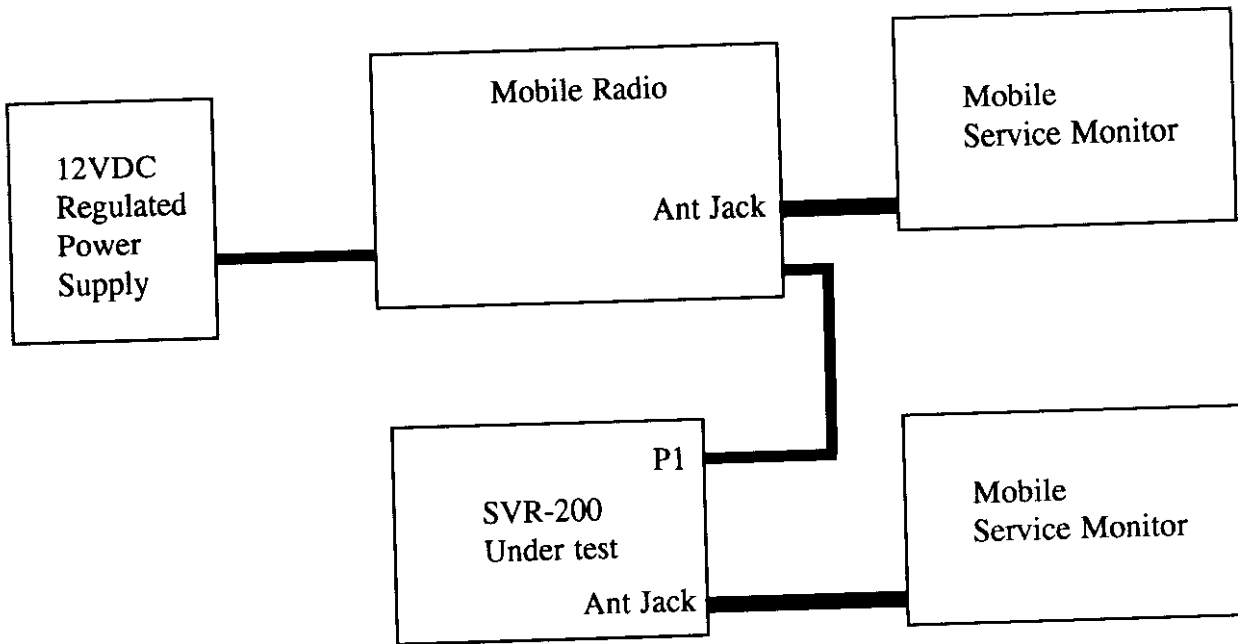

Figure 1 Test Equipment Set up