

ENGINEERING TEST REPORT

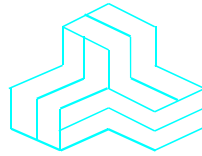

**Vehicle Radio Extender
Model: VRX1000 UHF
FCC ID: LO6-VRX1000UHF**

Applicant:

Futurecom Systems Group, ULC
3277 Langstaff Road
Concord, ON
Canada L4K 5P8

Tested in Accordance With

**Federal Communications Commission (FCC)
47 CFR, Parts 2 and 90**

UltraTech's File No.: 15FSG141_FCC90

This Test report is Issued under the Authority of
Tri M. Luu
Vice President of Engineering
UltraTech Group of Labs

Date: July 8, 2015

Report Prepared by: Dan Huynh

Tested by: Hung Trinh

Issued Date: July 8, 2015

Test Dates: May 8 - June 10, 2015

- *The results in this Test Report apply only to the sample(s) tested, and the sample tested is randomly selected.*
- *This report must not be used by the client to claim product endorsement by NVLAP or any agency of the US Government.*

UltraTech

3000 Bristol Circle, Oakville, Ontario, Canada, L6H 6G4
Tel.: (905) 829-1570 Fax.: (905) 829-8050
Website: www.ultratech-labs.com, Email: vic@ultratech-labs.com, Email: tri@ultratech-labs.com



91038



1309



46390-2049



NVLAP LAB
CODE 200093-0



SL2-IN-E-
1119R



Korea
KCC-RRR

CA2049



TL363_B



TPTDP
DA1300

TABLE OF CONTENTS

EXHIBIT 1. INTRODUCTION..... 1

1.1. SCOPE 1

1.2. RELATED SUBMITTAL(S)/GRANT(S) 1

1.3. NORMATIVE REFERENCES 1

EXHIBIT 2. PERFORMANCE ASSESSMENT 2

2.1. CLIENT INFORMATION 2

2.2. EQUIPMENT UNDER TEST (EUT) INFORMATION 2

2.3. EUT’S TECHNICAL SPECIFICATIONS..... 3

2.4. LIST OF EUT’S PORTS..... 4

EXHIBIT 3. EUT OPERATING CONDITIONS AND CONFIGURATIONS DURING TESTS 5

3.1. CLIMATE TEST CONDITIONS 5

3.2. OPERATIONAL TEST CONDITIONS & ARRANGEMENT FOR TEST SIGNALS..... 5

EXHIBIT 4. SUMMARY OF TEST RESULTS..... 6

4.1. LOCATION OF TESTS 6

4.2. APPLICABILITY & SUMMARY OF EMC EMISSION TEST RESULTS 6

4.3. MODIFICATIONS INCORPORATED IN THE EUT FOR COMPLIANCE PURPOSES 6

4.4. DEVIATION OF STANDARD TEST PROCEDURES..... 6

EXHIBIT 5. TEST DATA..... 7

5.1. RF POWER OUTPUT [§§ 2.1046 & 90.205]..... 7

5.2. MODULATION CHARACTERISTICS - AUDIO FREQUENCY RESPONSE [§ 2.1047(a)] 11

5.3. MODULATION CHARACTERISTICS - MODULATION LIMITING [§ 2.1047 (b)]..... 18

5.4. OCCUPIED BANDWIDTH & EMISSION MASK [§§ 2.1049, 90.209 & 90.210] 26

5.5. SPURIOUS EMISSIONS AT ANTENNA TERMINALS [§§ 2.1051, 2.1057, 90.210]..... 98

5.6. TRANSMITTER SPURIOUS/HARMONIC RADIATED EMISSIONS [§§ 2.1053, 2.1057 & 90.210] 126

5.7. FREQUENCY STABILITY [§§ 2.1055 & 90.213] 129

5.8. TRANSIENT FREQUENCY BEHAVIOR [§ 90.214] 131

5.9. EXPOSURE OF HUMANS TO RF FIELD [§§ 1.1310 & 2.1091]..... 139

EXHIBIT 6. TEST EQUIPMENT LIST 141

EXHIBIT 7. MEASUREMENT UNCERTAINTY 142

7.1. RADIATED EMISSION MEASUREMENT UNCERTAINTY 142

EXHIBIT 8. MEASUREMENT METHODS 143

8.1. CONDUCTED POWER MEASUREMENTS 143

8.2. RADIATED POWER MEASUREMENTS (ERP & EIRP) USING SUBSTITUTION METHOD 144

8.3. FREQUENCY STABILITY 147

8.4. EMISSION MASK 148

8.5. SPURIOUS EMISSIONS (CONDUCTED) 148

EXHIBIT 1. INTRODUCTION

1.1. SCOPE

Reference:	FCC Parts 2 and 90
Title:	Code of Federal Regulations (CFR), Title 47 –Telecommunication, Part 90 Private land mobile radio services
Purpose of Test:	To gain FCC Equipment Authorization for Radio operating in Part 90.
Test Procedures:	Both conducted and radiated emissions measurements were conducted in accordance with TIA/EIA Standard TIA-603-D – Land Mobile FM or PM Communications Equipment Measurement and performance Standards.

1.2. RELATED SUBMITTAL(S)/GRANT(S)

None

1.3. NORMATIVE REFERENCES

Publication	Year	Title
FCC CFR Parts 0-19, 80-End	2015	Code of Federal Regulations, Title 47 – Telecommunication
ANSI C63.4	2009	American National Standard for Methods of Measurement of Radio-Noise Emissions from Low-Voltage Electrical and Electronic Equipment in the Range of 9 kHz to 40 GHz
TIA/EIA 603, Edition D	2010	Land Mobile FM or PM Communications Equipment Measurement and Performance Standards
CISPR 22 & EN 55022	2008-09, Edition 6.0 2006	Information Technology Equipment - Radio Disturbance Characteristics - Limits and Methods of Measurement
CISPR 16-1-1 +A1 +A2	2006 2006 2007	Specification for radio disturbance and immunity measuring apparatus and methods. Part 1-1: Measuring Apparatus
CISPR 16-1-2 +A1 +A2	2003 2004 2006	Specification for radio disturbance and immunity measuring apparatus and methods. Part 1-2: Conducted disturbances

EXHIBIT 2. PERFORMANCE ASSESSMENT

2.1. CLIENT INFORMATION

APPLICANT	
Name:	Futurecom Systems Group, ULC
Address:	3277 Langstaff Road Concord, ON Canada L4K 5P8
Contact Person:	Mr. Tony Bombera Phone #: 905 660 5548 X225 Fax #: 905 660 6858 Email Address: tony.bombera@futurecom.com

MANUFACTURER	
Name:	Futurecom Systems Group, ULC
Address:	3277 Langstaff Road Concord, ON Canada L4K 5P8
Contact Person:	Mr. Tony Bombera Phone #: 905 660 5548 X225 Fax #: 905 660 6858 Email Address: tony.bombera@futurecom.com

2.2. EQUIPMENT UNDER TEST (EUT) INFORMATION

The following information (with the exception of the Date of Receipt) has been supplied by the applicant.

Brand Name:	Futurecom Systems Group, ULC
Product Name:	Vehicle Radio Extender
Model Name or Number:	VRX1000 UHF
Serial Number:	00000092
Type of Equipment:	Licensed Non-Broadcast Station Transmitter
Power Supply Requirement:	13.8V DC Nominal
Transmitting/Receiving Antenna Type:	Non-integral
Primary User Functions of EUT:	Radio coverage extender for portable radios

2.3. EUT'S TECHNICAL SPECIFICATIONS

Transmitter	
Equipment Type:	Mobile Stations
Intended Operating Environment:	Commercial, industrial or business environment
Power Supply Requirement:	13.8V DC 3A Nominal
RF Output Power Rating:	Programmable 0.5W – 3.0W
Operating Frequency Range:	380 - 512 MHz
RF Output Impedance:	50 Ω
Channel Spacing:	25 kHz, 12.5 kHz and 6.25 kHz
Modulation Employed:	Analog FM, P25 C4FM
Data Rate:	19200 bps, 9600 bps, 4800 bps
Emission Designation*:	16K0F3E, 11K0F3E 16K0F1E, 16K0F1D, 8K10F1E, 8K10F1D, 4K00F1E, 4K00F1D
Oscillator Frequency(ies):	14.4MHz, 109.65MHz, TX Frequency – 109.65MHz
Antenna Connector Type:	Mini UHF

*Necessary bandwidth determined using the Carson's formula: $B_n = 2M+2DK$

where: B_n = Necessary bandwidth in hertz

M = Maximum modulation frequency in hertz

D = Peak frequency deviation

K = An overall numerical factor which varies according to the emission and which depends upon the allowable signal distortion.

Standard Audio Modulation (12.5 kHz Channelization, Analog Voice):

M = 3 kHz; D = 2.5 kHz; K = 1

$B_n = 2M+2DK = 2(3 \text{ kHz}) + 2(2.5 \text{ kHz})(1) = 11 \text{ kHz}$

Emission Designator: 11K0F3E.

Standard Audio Modulation (25 kHz Channelization, Analog Voice):

M = 3 kHz; D = 5 kHz

$B_n = 2M+2DK = 2(3 \text{ kHz}) + 2(5 \text{ kHz})(1) = 16 \text{ kHz}$

Emission Designator: 16K0F3E

2.4. LIST OF EUT'S PORTS

Port Number	EUT's Port Description	Number of Identical Ports	Connector Type	Cable Type (Shielded/Non-shielded)
1	DC Power Input	1	M12	1m, unshielded
2	*Programming Connector	1	Mini USB	0.6m, Shielded
3	RF Connector	1	Mini UHF	0.6m, Shielded
4	Auxiliary/Options/Mobile Connector	1	DB-25	0.9m, Shielded

* Programming Connector is only used during programming. Nothing is connected to this connector during VRX1000 operation.

EXHIBIT 3. EUT OPERATING CONDITIONS AND CONFIGURATIONS DURING TESTS

3.1. CLIMATE TEST CONDITIONS

The climate conditions of the test environment are as follows:

Temperature:	21° C to 24° C
Humidity:	45 to 51%
Pressure:	102 kPa
Power input source:	13.8V DC nominal

3.2. OPERATIONAL TEST CONDITIONS & ARRANGEMENT FOR TEST SIGNALS

Operating Modes:	The transmitter was operated in a continuous transmission mode with the carrier modulated as specified in the Test Data.
Special Test Software:	N/A
Special Hardware Used:	N/A
Transmitter Test Antenna:	The EUT is tested with the transmitter antenna port terminated to a 50 Ω Load.

Transmitter Test Signals	
Frequency Band(s):	380 - 512 MHz
Test Frequency(ies):	380.1 MHz, 390.0 MHz and 399.9 MHz (not for FCC review) 406.2 MHz, 415.0 MHz, 429.9 MHz, 450.1 MHz, 470.0 MHz and 511.9 MHz
Transmitter Wanted Output Test Signals:	
• Transmitter Power (measured maximum output power):	34.90 dBm
• Normal Test Modulation:	F3E, F1E and F1D
• Modulating signal source:	External for analog mode/Internal for digital mode

EXHIBIT 4. SUMMARY OF TEST RESULTS

4.1. LOCATION OF TESTS

All of the measurements described in this report were performed at Ultratech Group of Labs located in the city of Oakville, Province of Ontario, Canada.

Radiated Emissions were performed at the Ultratech's 3-10 TDK Semi-Anechoic Chamber situated in the Town of Oakville, province of Ontario. This test site been calibrated in accordance with ANSI C63.4, and found to be in compliance with the requirements of Sec. 2.948 of the FCC Rules. The descriptions and site measurement data of the Oakville 3-10 TDK Semi-Anechoic Chamber has been filed with FCC office (FCC File No.: 91038) and Industry Canada office (Industry Canada File No.: 2049A-3). Expiry Date: 2017-04-02.

4.2. APPLICABILITY & SUMMARY OF EMC EMISSION TEST RESULTS

FCC Section(s)	Test Requirements	Applicability (Yes/No)
2.1046 & 90.205	RF Power Output	Yes
2.1047(a)	Modulation Characteristics - Audio Frequency Response	Yes
2.1047(b)	Modulation Characteristics - Modulation Limiting	Yes
2.1049, 90.209 & 90.210	Occupied Bandwidth and Emission Limitations/Masks	Yes
2.1051, 2.1057, 90.210 & 90.543(b)	Spurious Emissions at Antenna Terminal	Yes
2.1053, 2.1057 & 90.210	Field Strength of Spurious Emissions	Yes
2.1055 & 90.213	Frequency Stability	Yes
90.214	Transient Frequency Behavior	Yes
1.1307, 1.1310 & 2.1091	RF Exposure Limit	Yes

4.3. MODIFICATIONS INCORPORATED IN THE EUT FOR COMPLIANCE PURPOSES

None

4.4. DEVIATION OF STANDARD TEST PROCEDURES

None

ULTRATECH GROUP OF LABS

3000 Bristol Circle, Oakville, Ontario, Canada L6H 6G4
Tel. #: 905-829-1570, Fax. #: 905-829-8050, Email: vic@ultratech-labs.com, Website: <http://www.ultratech-labs.com>

File #: 15FSG141_FCC90
July 8, 2015

All test results contained in this engineering test report are traceable to National Institute of Standards and Technology (NIST)

EXHIBIT 5. TEST DATA

5.1. RF POWER OUTPUT [§§ 2.1046 & 90.205]

5.1.1. Limits

Please refer to FCC 47 CFR § 90.205 for specification details.

5.1.2. Method of Measurements

Refer to Section 8.1 of this report for measurement details.

5.1.3. Test Arrangement

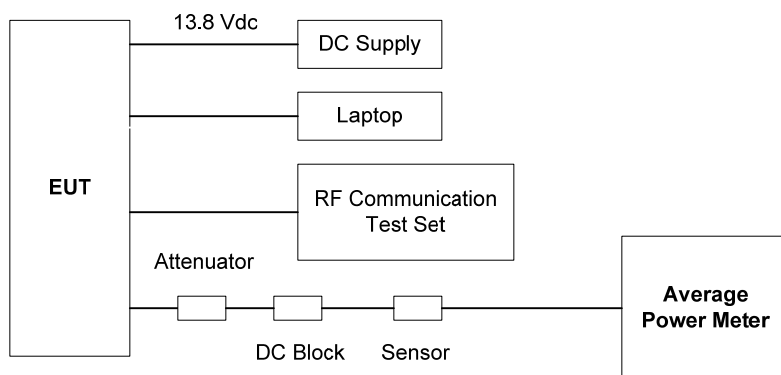

5.1.4. Test Data

Channel Spacing (kHz)	Modulation	Power Setting	Frequency (MHz)	Measured Conducted Power Output		Power Output Rating		
				(dBm)	(W)	(dBm)	(W)	
25	Analog FM	High	380.1	34.83	3.04	34.77	3	
			390.0	34.82	3.03	34.77	3	
			399.9	34.88	3.08	34.77	3	
			406.2	34.90	3.09	34.77	3	
			415.0	34.86	3.06	34.77	3	
			429.9	34.75	2.99	34.77	3	
			450.1	34.79	3.01	34.77	3	
			470.0	34.79	3.01	34.77	3	
		511.9	34.68	2.94	34.77	3		
		Low	380.1	27.07	0.51	26.99	0.5	
			390.0	27.10	0.51	26.99	0.5	
			399.9	27.16	0.52	26.99	0.5	
			406.2	27.12	0.52	26.99	0.5	
			415.0	27.14	0.52	26.99	0.5	
			429.9	27.05	0.51	26.99	0.5	
			450.1	27.06	0.51	26.99	0.5	
	470.0		27.01	0.50	26.99	0.5		
	511.9	26.92	0.49	26.99	0.5			
		Digital	High	380.1	34.83	3.04	34.77	3
				390.0	34.82	3.03	34.77	3
				399.9	34.88	3.08	34.77	3
				406.2	34.90	3.09	34.77	3
				415.0	34.86	3.06	34.77	3
				429.9	34.75	2.99	34.77	3
450.1				34.79	3.01	34.77	3	
470.0	34.79			3.01	34.77	3		
511.9	34.68	2.94	34.77	3				
Low	380.1	27.07	0.51	26.99	0.5			
	390.0	27.10	0.51	26.99	0.5			
	399.9	27.16	0.52	26.99	0.5			
	406.2	27.12	0.52	26.99	0.5			
	415.0	27.14	0.52	26.99	0.5			
	429.9	27.05	0.51	26.99	0.5			
	450.1	27.06	0.51	26.99	0.5			
	470.0	27.01	0.50	26.99	0.5			
511.9	26.92	0.49	26.99	0.5				

ULTRATECH GROUP OF LABS

3000 Bristol Circle, Oakville, Ontario, Canada L6H 6G4
 Tel. #: 905-829-1570, Fax. #: 905-829-8050, Email: vic@ultratech-labs.com, Website: <http://www.ultratech-labs.com>

File #: 15FSG141_FCC90
 July 8, 2015

All test results contained in this engineering test report are traceable to National Institute of Standards and Technology (NIST)

Channel Spacing (kHz)	Modulation	Power Setting	Frequency (MHz)	Measured Conducted Power Output		Power Output Rating	
				(dBm)	(W)	(dBm)	(W)
12.5	Analog FM	High	380.1	34.83	3.04	34.77	3
			390.0	34.82	3.03	34.77	3
			399.9	34.88	3.08	34.77	3
			406.2	34.90	3.09	34.77	3
			415.0	34.86	3.06	34.77	3
			429.9	34.75	2.99	34.77	3
			450.1	34.79	3.01	34.77	3
		470.0	34.79	3.01	34.77	3	
		511.9	34.68	2.94	34.77	3	
		Low	380.1	27.07	0.51	26.99	0.5
			390.0	27.10	0.51	26.99	0.5
			399.9	27.16	0.52	26.99	0.5
			406.2	27.12	0.52	26.99	0.5
			415.0	27.14	0.52	26.99	0.5
	429.9		27.05	0.51	26.99	0.5	
	450.1		27.06	0.51	26.99	0.5	
	470.0	27.01	0.50	26.99	0.5		
	511.9	26.92	0.49	26.99	0.5		
	Digital	High	380.1	34.83	3.04	34.77	3
			390.0	34.82	3.03	34.77	3
			399.9	34.88	3.08	34.77	3
			406.2	34.90	3.09	34.77	3
			415.0	34.86	3.06	34.77	3
			429.9	34.75	2.99	34.77	3
			450.1	34.79	3.01	34.77	3
		470.0	34.79	3.01	34.77	3	
		511.9	34.68	2.94	34.77	3	
		Low	380.1	27.07	0.51	26.99	0.5
390.0			27.10	0.51	26.99	0.5	
399.9			27.16	0.52	26.99	0.5	
406.2			27.12	0.52	26.99	0.5	
415.0			27.14	0.52	26.99	0.5	
429.9	27.05		0.51	26.99	0.5		
450.1	27.06		0.51	26.99	0.5		
470.0	27.01	0.50	26.99	0.5			
511.9	26.92	0.49	26.99	0.5			

ULTRATECH GROUP OF LABS

3000 Bristol Circle, Oakville, Ontario, Canada L6H 6G4
 Tel. #: 905-829-1570, Fax. #: 905-829-8050, Email: vic@ultratech-labs.com, Website: <http://www.ultratech-labs.com>

File #: 15FSG141_FCC90
 July 8, 2015

All test results contained in this engineering test report are traceable to National Institute of Standards and Technology (NIST)

Channel Spacing (kHz)	Modulation	Power Setting	Frequency (MHz)	Measured Conducted Power Output		Power Output Rating	
				(dBm)	(W)	(dBm)	(W)
6.25	Analog FM	High	380.1	34.83	3.04	34.77	3
			390.0	34.82	3.03	34.77	3
			399.9	34.88	3.08	34.77	3
			406.2	34.90	3.09	34.77	3
			415.0	34.86	3.06	34.77	3
			429.9	34.75	2.99	34.77	3
			450.1	34.79	3.01	34.77	3
		470.0	34.79	3.01	34.77	3	
		511.9	34.68	2.94	34.77	3	
		Low	380.1	27.07	0.51	26.99	0.5
			390.0	27.10	0.51	26.99	0.5
			399.9	27.16	0.52	26.99	0.5
			406.2	27.12	0.52	26.99	0.5
			415.0	27.14	0.52	26.99	0.5
	429.9		27.05	0.51	26.99	0.5	
	450.1		27.06	0.51	26.99	0.5	
	470.0	27.01	0.50	26.99	0.5		
	511.9	26.92	0.49	26.99	0.5		
	Digital	High	380.1	34.83	3.04	34.77	3
			390.0	34.82	3.03	34.77	3
			399.9	34.88	3.08	34.77	3
			406.2	34.90	3.09	34.77	3
			415.0	34.86	3.06	34.77	3
			429.9	34.75	2.99	34.77	3
			450.1	34.79	3.01	34.77	3
		470.0	34.79	3.01	34.77	3	
		511.9	34.68	2.94	34.77	3	
		Low	380.1	27.07	0.51	26.99	0.5
390.0			27.10	0.51	26.99	0.5	
399.9			27.16	0.52	26.99	0.5	
406.2			27.12	0.52	26.99	0.5	
415.0			27.14	0.52	26.99	0.5	
429.9	27.05		0.51	26.99	0.5		
450.1	27.06		0.51	26.99	0.5		
470.0	27.01	0.50	26.99	0.5			
511.9	26.92	0.49	26.99	0.5			

ULTRATECH GROUP OF LABS

3000 Bristol Circle, Oakville, Ontario, Canada L6H 6G4
 Tel. #: 905-829-1570, Fax. #: 905-829-8050, Email: vic@ultratech-labs.com, Website: <http://www.ultratech-labs.com>

File #: 15FSG141_FCC90
 July 8, 2015

All test results contained in this engineering test report are traceable to National Institute of Standards and Technology (NIST)

5.2. MODULATION CHARACTERISTICS - AUDIO FREQUENCY RESPONSE [§ 2.1047(a)]

5.2.1. Limits

§ 2.1047(a): Voice modulated communication equipment. A curve or equivalent data showing the frequency response of the audio modulating circuit over a range of 100 to 5000 Hz shall be submitted. For equipment required to have an audio low-pass filter, a curve showing the frequency response of the filter or of all circuitry installed between the modulation limiter and the modulated stage shall be submitted.

5.2.2. Method of Measurements

The rated audio input signal was applied to the input of the audio low-pass filter (or of all modulation stages) using an audio oscillator, this input signal level and its corresponding output signal were then measured and recorded using the FFT Digital Spectrum Analyzer. Tests were repeated at different audio signal frequencies from 0 to 50 KHz.

5.2.3. Test Arrangement

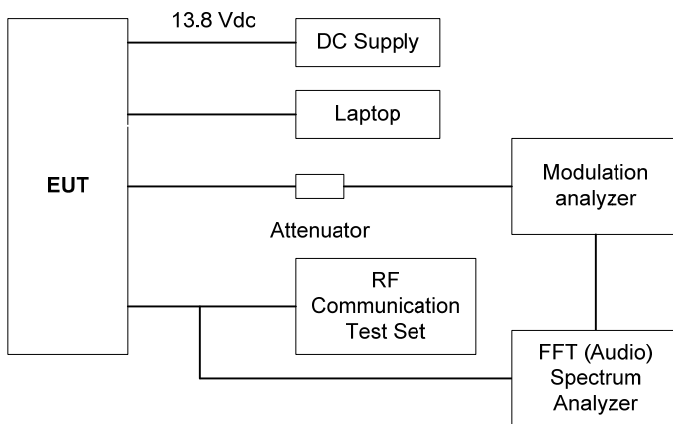

5.2.4. Test Data

5.2.4.1. 25 kHz Channel Spacing, 406.2 MHz, F3E, Frequency of All Modulation States

Remark: Due to the difficulty of measuring the Frequency Response of the internal low-pass filter, the Frequency Response of All Modulation States is performed to show the roll-off at 3 kHz in comparison with the recommended audio filter attenuation.

Frequency (kHz)	Audio In (dBV)	Audio Out (dBV)	Attenuation (Out - In) (dB)	Attenuation Rel. to 1 KHz (dB)	Recommended Attenuation (dB)
0.1	-9.72	-50.50	-40.8	-56.4	--
0.2	-9.72	-45.02	-35.3	-50.9	--
0.4	-9.72	-1.87	7.9	-7.8	--
0.6	-9.72	1.38	11.1	-4.5	--
0.8	-9.72	3.95	13.7	-1.9	--
1.0	-9.72	5.89	15.6	0.0	--
1.5	-9.72	4.50	14.2	-1.4	--
2.0	-9.72	1.25	11.0	-4.6	--
2.5	-9.72	0.30	10.0	-5.6	--
3.0	-9.72	-1.25	8.5	-7.1	0
3.5	-9.72	-4.50	5.2	-10.4	-4
4.0	-9.72	-6.50	3.2	-12.4	-7
4.5	-9.72	<-48.00	<-38.3	<-53.9	-11
5.0	-9.72	<-48.00	<-38.3	<-53.9	-13
6.0	-9.72	<-48.00	<-38.3	<-53.9	-18
7.0	-9.72	<-48.00	<-38.3	<-53.9	-22
8.0	-9.72	<-48.00	<-38.3	<-53.9	-26
9.0	-9.72	<-48.00	<-38.3	<-53.9	-29
10.0	-9.72	<-48.00	<-38.3	<-53.9	-31
12.0	-9.72	<-48.00	<-38.3	<-53.9	-36
14.0	-9.72	<-48.00	<-38.3	<-53.9	-40
16.0	-9.72	<-48.00	<-38.3	<-53.9	-44
18.0	-9.72	<-48.00	<-38.3	<-53.9	-47
20.0	-9.72	<-48.00	<-38.3	<-53.9	-49
22.0	-9.72	<-48.00	<-38.3	<-53.9	-50
25.0	-9.72	<-48.00	<-38.3	<-53.9	-50
30.0	-9.72	<-48.00	<-38.3	<-53.9	-50
35.0	-9.72	<-48.00	<-38.3	<-53.9	-50
40.0	-9.72	<-48.00	<-38.3	<-53.9	-50
45.0	-9.72	<-48.00	<-38.3	<-53.9	-50
50.0	-9.72	<-48.00	<-38.3	<-53.9	-50

ULTRATECH GROUP OF LABS

3000 Bristol Circle, Oakville, Ontario, Canada L6H 6G4
 Tel. #: 905-829-1570, Fax. #: 905-829-8050, Email: vic@ultratech-labs.com, Website: <http://www.ultratech-labs.com>

File #: 15FSG141_FCC90
 July 8, 2015

All test results contained in this engineering test report are traceable to National Institute of Standards and Technology (NIST)

Audio Frequency Response
25 kHz Channel Spacing

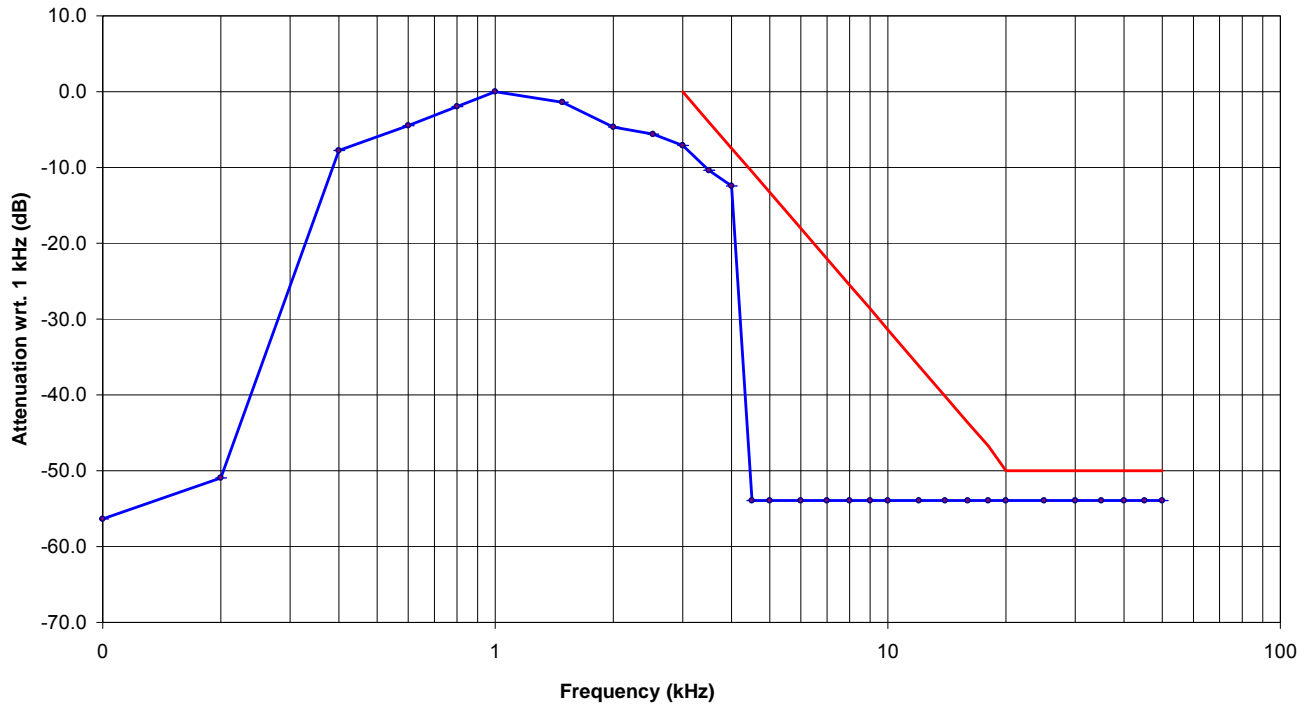

ULTRATECH GROUP OF LABS

3000 Bristol Circle, Oakville, Ontario, Canada L6H 6G4
Tel. #: 905-829-1570, Fax. #: 905-829-8050, Email: vic@ultratech-labs.com, Website: <http://www.ultratech-labs.com>

File #: 15FSG141_FCC90

July 8, 2015

All test results contained in this engineering test report are traceable to National Institute of Standards and Technology (NIST)

5.2.4.2. 12.5 kHz Channel Spacing, 406.2 MHz, F3E, Frequency of All Modulation States

Remark: Due to the difficulty of measuring the Frequency Response of the internal low-pass filter, the Frequency Response of All Modulation States is performed to show the roll-off at 3 kHz in comparison with the recommended audio filter attenuation.

Frequency (kHz)	Audio In (dBV)	Audio Out (dBV)	Attenuation (Out - In) (dB)	Attenuation Rel. to 1 KHz (dB)	Recommended Attenuation (dB)
0.1	-9.72	-60.50	-50.8	-60.4	--
0.2	-9.72	-35.90	-35.9	-45.5	--
0.4	-9.72	-7.89	1.8	-7.8	--
0.6	-9.72	-4.53	5.2	-4.4	--
0.8	-9.72	-1.92	7.8	-1.8	--
1.0	-9.72	-0.12	9.6	0.0	--
1.5	-9.72	3.30	13.0	3.4	--
2.0	-9.72	3.85	13.6	4.0	--
2.5	-9.72	3.95	13.7	4.1	--
3.0	-9.72	-0.20	9.5	-0.1	0
3.5	-9.72	-5.60	4.1	-5.5	-4
4.0	-9.72	-12.20	-2.5	-12.1	-7
4.5	-9.72	<-60.00	<-50.3	<-59.9	-11
5.0	-9.72	<-60.00	<-50.3	<-59.9	-13
6.0	-9.72	<-60.00	<-50.3	<-59.9	-18
7.0	-9.72	<-60.00	<-50.3	<-59.9	-22
8.0	-9.72	<-60.00	<-50.3	<-59.9	-26
9.0	-9.72	<-60.00	<-50.3	<-59.9	-29
10.0	-9.72	<-60.00	<-50.3	<-59.9	-31
12.0	-9.72	<-60.00	<-50.3	<-59.9	-36
14.0	-9.72	<-60.00	<-50.3	<-59.9	-40
16.0	-9.72	<-60.00	<-50.3	<-59.9	-44
18.0	-9.72	<-60.00	<-50.3	<-59.9	-47
20.0	-9.72	<-60.00	<-50.3	<-59.9	-49
22.0	-9.72	<-60.00	<-50.3	<-59.9	-50
25.0	-9.72	<-60.00	<-50.3	<-59.9	-50
30.0	-9.72	<-60.00	<-50.3	<-59.9	-50
35.0	-9.72	<-60.00	<-50.3	<-59.9	-50
40.0	-9.72	<-60.00	<-50.3	<-59.9	-50
45.0	-9.72	<-60.00	<-50.3	<-59.9	-50
50.0	-9.72	<-60.00	<-50.3	<-59.9	-50

Audio Frequency Response
12.5 kHz Channel Spacing

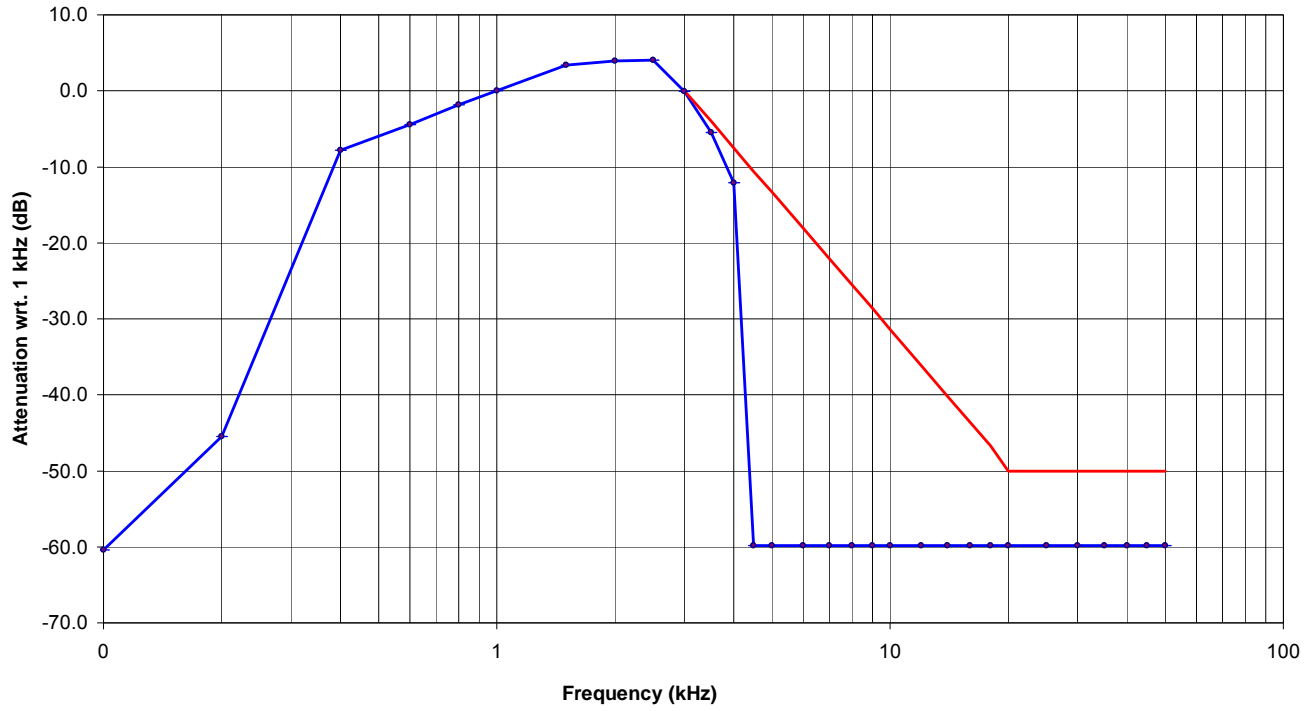

5.2.4.3. 6.25 kHz Channel Spacing, 406.2 MHz, F3E, Frequency of All Modulation States

Remark: Due to the difficulty of measuring the Frequency Response of the internal low-pass filter, the Frequency Response of All Modulation States is performed to show the roll-off at 3 kHz in comparison with the recommended audio filter attenuation.

Frequency (kHz)	Audio In (dBV)	Audio Out (dBV)	Attenuation (Out - In) (dB)	Attenuation Rel. to 1 KHz (dB)	Recommended Attenuation (dB)
0.1	-5.92	-48.50	-42.6	-40.0	--
0.2	-5.92	-24.50	-18.6	-16.0	--
0.4	-5.92	-16.30	-10.4	-7.8	--
0.6	-5.92	-12.87	-7.0	-4.4	--
0.8	-5.92	-10.17	-4.3	-1.7	--
1.0	-5.92	-8.5	-2.6	0.0	--
1.5	-5.92	-8.30	-2.4	0.2	--
2.0	-5.92	-9.16	-3.2	-0.7	--
2.5	-5.92	-10.89	-5.0	-2.4	--
3.0	-5.92	-15.07	-9.2	-6.6	0
3.5	-5.92	-20.90	-15.0	-12.4	-4
4.0	-5.92	-37.09	-31.2	-28.6	-7
4.5	-5.92	<-60.00	<-54.1	<-51.5	-11
5.0	-5.92	<-60.00	<-54.1	<-51.5	-13
6.0	-5.92	<-60.00	<-54.1	<-51.5	-18
7.0	-5.92	<-60.00	<-54.1	<-51.5	-22
8.0	-5.92	<-60.00	<-54.1	<-51.5	-26
9.0	-5.92	<-60.00	<-54.1	<-51.5	-29
10.0	-5.92	<-60.00	<-54.1	<-51.5	-31
12.0	-5.92	<-60.00	<-54.1	<-51.5	-36
14.0	-5.92	<-60.00	<-54.1	<-51.5	-40
16.0	-5.92	<-60.00	<-54.1	<-51.5	-44
18.0	-5.92	<-60.00	<-54.1	<-51.5	-47
20.0	-5.92	<-60.00	<-54.1	<-51.5	-49
22.0	-5.92	<-60.00	<-54.1	<-51.5	-50
25.0	-5.92	<-60.00	<-54.1	<-51.5	-50
30.0	-5.92	<-60.00	<-54.1	<-51.5	-50
35.0	-5.92	<-60.00	<-54.1	<-51.5	-50
40.0	-5.92	<-60.00	<-54.1	<-51.5	-50
45.0	-5.92	<-60.00	<-54.1	<-51.5	-50
50.0	-5.92	<-60.00	<-54.1	<-51.5	-50

Audio Frequency Response
6.25 kHz Channel Spacing

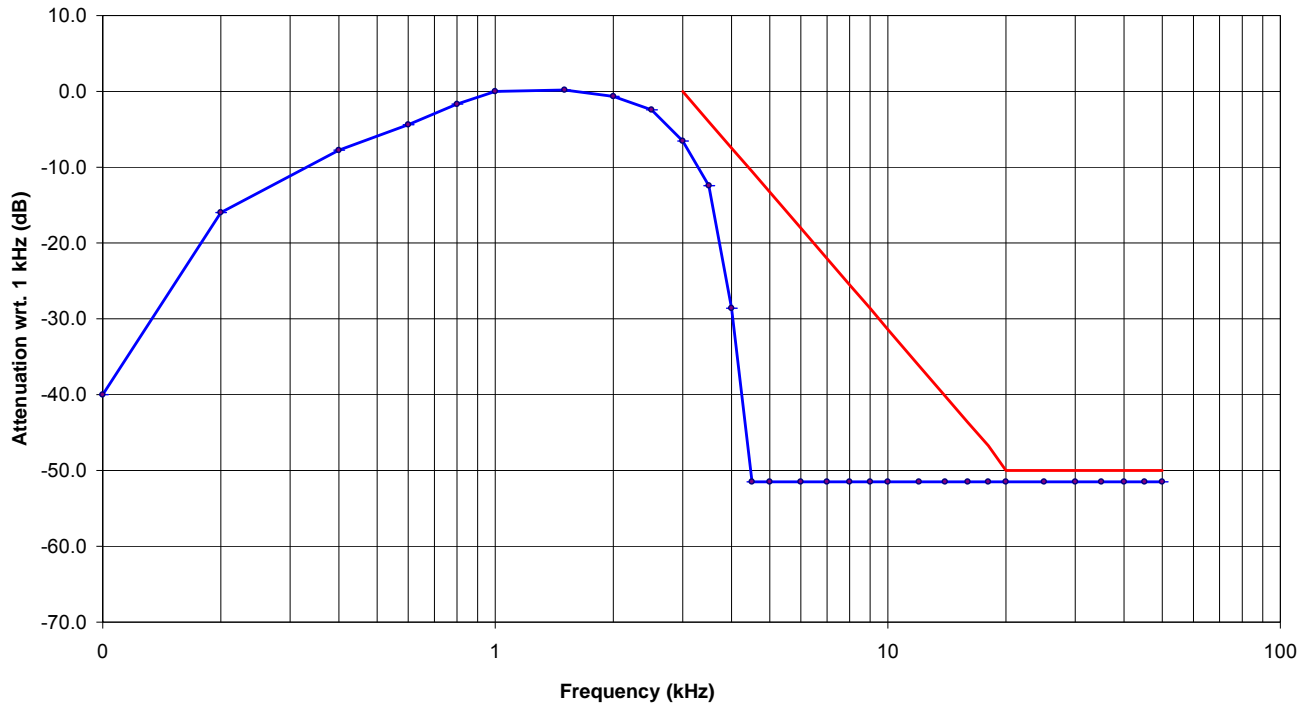

ULTRATECH GROUP OF LABS

3000 Bristol Circle, Oakville, Ontario, Canada L6H 6G4
Tel. #: 905-829-1570, Fax. #: 905-829-8050, Email: vic@ultratech-labs.com, Website: <http://www.ultratech-labs.com>

File #: 15FSG141_FCC90

July 8, 2015

All test results contained in this engineering test report are traceable to National Institute of Standards and Technology (NIST)

5.3. MODULATION CHARACTERISTICS - MODULATION LIMITING [§ 2.1047 (b)]

5.3.1. Limits

§ 2.1047(b): Equipment which employs modulation limiting. A curve or family of curves showing the percentage of modulation versus the modulation input voltage shall be supplied. The information submitted shall be sufficient to show modulation limiting capability throughout the range of modulating frequencies and input modulating signal levels employed.

Recommended frequency deviation characteristics are given below:

- 1.25 kHz for 6.25 kHz Channel Spacing System
- 2.5 kHz for 12.5 kHz Channel Spacing System
- 5 kHz for 25 kHz Channel Spacing System

5.3.2. Method of Measurements

For Audio Transmitter: The carrier frequency deviation was measured with the tone input signal level varied from 0 Vp to audio input rating level plus 16 dB at frequencies 0.1, 0.5, 1.0, 3.0 and 5.0 kHz. The maximum deviation was recorded at each test condition.

For Data Transmitter with Maximum Frequency Deviation set by Factory: The EUT was set at maximum frequency deviation, and its peak frequency deviation was then measured using EUT's internal random data source.

5.3.3. Test Arrangement

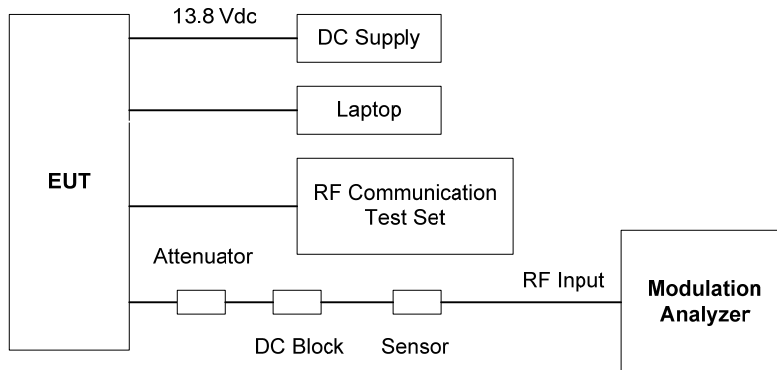

5.3.4. Test Data

5.3.4.1. Voice Modulation Limiting for 25 kHz Channel Spacing Operation, 406.2 MHz

Modulating Signal Level (mVrms)	Peak Frequency Deviation (kHz) at the following modulating frequency:					Maximum Limit (kHz)
	0.1 kHz	0.5 kHz	1.0 kHz	3.0 kHz	5.0 kHz	
50	0.39	0.55	0.75	1.48	0.39	5
100	0.39	0.75	1.16	2.67	0.39	5
150	0.39	0.95	1.59	3.95	0.39	5
200	0.39	1.19	2.05	4.80	0.39	5
250	0.39	1.38	2.48	4.90	0.39	5
300	0.39	1.59	2.92	4.90	0.39	5
350	0.39	1.80	3.35	4.90	0.39	5
400	0.39	2.02	3.78	4.90	0.39	5
450	0.39	2.22	4.29	4.90	0.39	5
500	0.39	2.43	4.61	4.90	0.39	5
600	0.39	2.87	4.65	4.90	0.39	5
700	0.39	3.40	4.70	4.90	0.39	5
800	0.39	3.90	4.70	4.90	0.39	5
900	0.39	4.20	4.70	4.90	0.39	5
1000	0.39	4.60	4.70	4.90	0.39	5

Voice Signal Input Level = STD MOD Level + 16 dB = 50.10 dB(mVrms) + 16 dB = 66.10 dB(mVrms) = 2018 mVrms		
Modulation Frequency (kHz)	Peak Deviation (kHz)	Maximum Limit (kHz)
0.1	0.9	5
0.2	4.9	5
0.4	4.3	5
0.6	4.3	5
0.8	4.3	5
1.0	4.4	5
1.2	4.6	5
1.4	4.5	5
1.6	4.5	5
1.8	4.5	5
2.0	4.5	5
2.5	4.6	5
3.0	4.9	5
3.5	4.4	5
4.0	2.8	5
4.5	0.6	5
5.0	0.1	5
6.0	0.2	5
7.0	1.2	5
8.0	2.0	5
9.0	2.2	5
10.0	0.2	5

5.3.4.2. Voice Modulation Limiting for 12.5 kHz Channel Spacing Operation, 406.2 MHz

Modulating Signal Level (mVrms)	Peak Frequency Deviation (kHz) at the following modulating frequency:					Maximum Limit (kHz)
	0.1 kHz	0.5 kHz	1.0 kHz	3.0 kHz	5.0 kHz	
50	0.40	0.45	0.54	0.90	0.40	2.5
100	0.40	0.55	0.75	1.42	0.40	2.5
150	0.40	0.64	0.95	1.98	0.40	2.5
200	0.40	0.75	1.18	2.33	0.40	2.5
250	0.40	0.85	1.39	2.33	0.40	2.5
300	0.40	0.95	1.60	2.33	0.40	2.5
350	0.40	1.05	1.82	2.33	0.40	2.5
400	0.40	1.16	2.04	2.38	0.40	2.5
450	0.40	1.26	2.25	2.38	0.40	2.5
500	0.40	1.36	2.41	2.40	0.40	2.5
600	0.40	1.58	2.44	2.48	0.40	2.5
700	0.40	1.79	2.46	2.48	0.40	2.5
800	0.40	2.05	2.47	2.48	0.40	2.5
900	0.40	2.20	2.47	2.48	0.40	2.5
1000	0.40	2.40	2.47	2.48	0.40	2.5

Voice Signal Input Level = STD MOD Level + 16 dB = 50.10 dB(mVrms) + 16 dB = 66.10 dB(mVrms) = 2018 mVrms		
Modulation Frequency (kHz)	Peak Deviation (kHz)	Maximum Limit (kHz)
0.1	0.5	2.5
0.2	1.1	2.5
0.4	2.2	2.5
0.6	2.3	2.5
0.8	2.3	2.5
1.0	2.3	2.5
1.2	2.4	2.5
1.4	2.4	2.5
1.6	2.4	2.5
1.8	2.4	2.5
2.0	2.4	2.5
2.5	2.2	2.5
3.0	2.2	2.5
3.5	1.3	2.5
4.0	0.9	2.5
4.5	0.1	2.5
5.0	0.0	2.5
6.0	0.2	2.5
7.0	0.4	2.5
8.0	1.0	2.5
9.0	0.0	2.5
10.0	0.0	2.5

5.3.4.3. Voice Modulation Limiting for 6.25 kHz Channel Spacing Operation, 406.2 MHz

Modulating Signal Level (mVrms)	Peak Frequency Deviation (kHz) at the following modulating frequency:					Maximum Limit (kHz)
	0.1 kHz	0.5 kHz	1.0 kHz	3.0 kHz	5.0 kHz	
50	0.38	0.39	0.41	0.41	0.38	1.25
100	0.38	0.40	0.45	0.47	0.38	1.25
150	0.38	0.43	0.49	0.54	0.38	1.25
200	0.38	0.45	0.49	0.58	0.38	1.25
250	0.38	0.45	0.59	0.58	0.38	1.25
300	0.38	0.50	0.64	0.58	0.38	1.25
350	0.38	0.50	0.69	0.58	0.38	1.25
400	0.38	0.54	0.75	0.58	0.38	1.25
450	0.38	0.56	0.80	0.58	0.38	1.25
500	0.38	0.60	0.84	0.60	0.38	1.25
600	0.38	0.64	0.84	0.60	0.38	1.25
700	0.38	0.68	0.84	0.60	0.38	1.25
800	0.38	0.74	0.84	0.60	0.38	1.25
900	0.38	0.78	0.84	0.60	0.38	1.25
1000	0.38	0.83	0.84	0.60	0.38	1.25

Voice Signal Input Level = STD MOD Level + 16 dB = 54 dB(mVrms) + 16 dB = 70 dB(mVrms) = 3162 mVrms		
Modulation Frequency (kHz)	Peak Deviation (kHz)	Maximum Limit (kHz)
0.1	0.2	1.25
0.2	0.5	1.25
0.4	0.6	1.25
0.6	0.6	1.25
0.8	0.6	1.25
1.0	0.6	1.25
1.2	0.6	1.25
1.4	0.6	1.25
1.6	0.6	1.25
1.8	0.6	1.25
2.0	0.6	1.25
2.5	0.5	1.25
3.0	0.4	1.25
3.5	0.3	1.25
4.0	0.3	1.25
4.5	0.3	1.25
5.0	0.1	1.25
6.0	0.1	1.25
7.0	0.1	1.25
8.0	0.1	1.25
9.0	0.1	1.25
10.0	0.1	1.25

5.3.4.4. Data Modulation Limiting (Factory Setting)

Operating Mode	Data Rate	Peak Frequency Deviation (kHz)
Digital 25 kHz C4FM	Factory default setting	6.25
Digital 12.5 kHz C4FM	Factory default setting	2.9
Digital 6.25 kHz C4FM	Factory default setting	0.6

5.4. OCCUPIED BANDWIDTH & EMISSION MASK [§§ 2.1049, 90.209 & 90.210]

5.4.1. Limits

§90.209 Bandwidth limitations

Frequency band (MHz)	Channel spacing (kHz)	Authorized bandwidth (kHz)
406-512 ²	¹ 6.25	^{1 3} 20/11.25/6

¹For stations authorized on or after August 18, 1995.

²Bandwidths for radiolocation stations in the 420-450 MHz band and for stations operating in bands subject to this footnote will be reviewed and authorized on a case-by-case basis.

³Operations using equipment designed to operate with a 25 kHz channel bandwidth will be authorized a 20 kHz bandwidth. Operations using equipment designed to operate with a 12.5 kHz channel bandwidth will be authorized a 11.25 kHz bandwidth. Operations using equipment designed to operate with a 6.25 kHz channel bandwidth will be authorized a 6 kHz bandwidth. All stations must operate on channels with a bandwidth of 12.5 kHz or less beginning January 1, 2013, unless the operations meet the efficiency standard of §90.203(j)(3).

§90.210 Emission masks

Frequency band (MHz)	Mask for equipment with audio low pass filter	Mask for equipment without audio low pass filter
421-512 ^{1 2}	B, D, or E	C, D, or E

¹Equipment designed to operate with a 25 kHz channel bandwidth must meet the requirements of Emission Mask B or C, as applicable. Equipment designed to operate with a 12.5 kHz channel bandwidth must meet the requirements of Emission Mask D, and equipment designed to operate with a 6.25 kHz channel bandwidth must meet the requirements of Emission Mask E.

²Equipment may alternatively meet the Adjacent Channel Power limits of §90.221.

5.4.2. Method of Measurements

Refer to Section 8.4 of this report for measurement details.

5.4.3. Test Arrangement

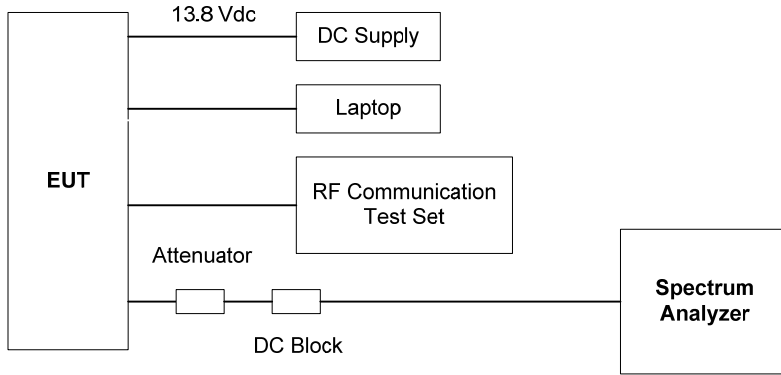

5.4.4. Test Data

5.4.4.1. 99% Occupied Bandwidth

Remark: 99% Occupied Bandwidth measurements were done using the built-in auto function of the analyzer.

Operating Mode	Frequency (MHz)	Measured 99% OBW at Maximum Freq. Deviation (KHz)	Maximum Authorized Bandwidth (KHz)
25 kHz Channel Spacing Analog	380.1	15.21	20.0
	390.0	15.03	20.0
	399.9	14.91	20.0
	406.2	15.15	20.0
	415.0	14.91	20.0
	429.9	14.97	20.0
	450.1	15.21	20.0
	470.0	15.03	20.0
	511.9	14.91	20.0

Operating Mode	Frequency (MHz)	Measured 99% OBW at Maximum Freq. Deviation (KHz)	Maximum Authorized Bandwidth (KHz)
25 kHz Channel Spacing Digital at 19.2 kbps	380.1	13.53	20.0
	390.0	13.29	20.0
	399.9	13.47	20.0
	406.2	13.23	20.0
	415.0	13.59	20.0
	429.9	13.29	20.0
	450.1	13.35	20.0
	470.0	13.23	20.0
	511.9	13.11	20.0
12.5 kHz Channel Spacing Analog	380.1	9.66	11.25
	390.0	9.62	11.25
	399.9	9.74	11.25
	406.2	9.66	11.25
	415.0	9.66	11.25
	429.9	9.70	11.25
	450.1	9.74	11.25
	470.0	9.78	11.25
	511.9	9.66	11.25
12.5 kHz Channel Spacing Digital at 9.6 kbps	380.1	7.94	11.25
	390.0	8.02	11.25
	399.9	8.02	11.25
	406.2	7.98	11.25
	415.0	8.06	11.25
	429.9	8.06	11.25
	450.1	8.02	11.25
	470.0	8.02	11.25
	511.9	7.98	11.25

ULTRATECH GROUP OF LABS

3000 Bristol Circle, Oakville, Ontario, Canada L6H 6G4
 Tel. #: 905-829-1570, Fax. #: 905-829-8050, Email: vic@ultratech-labs.com, Website: <http://www.ultratech-labs.com>

File #: 15FSG141_FCC90
 July 8, 2015

All test results contained in this engineering test report are traceable to National Institute of Standards and Technology (NIST)

Operating Mode	Frequency (MHz)	Measured 99% OBW at Maximum Freq. Deviation (KHz)	Maximum Authorized Bandwidth (KHz)
6.25 kHz Channel Spacing Digital at 4.8 kbps	380.1	3.30	6
	390.0	3.21	6
	399.9	3.22	6
	406.2	3.22	6
	415.0	3.21	6
	429.9	3.27	6
	450.1	3.29	6
	470.0	3.30	6
	511.9	3.35	6

See the following plots for detailed measurements.

Plot 5.4.4.1.1. 99% Occupied Bandwidth, 25 kHz Channel Spacing, Analog, 381.1 MHz

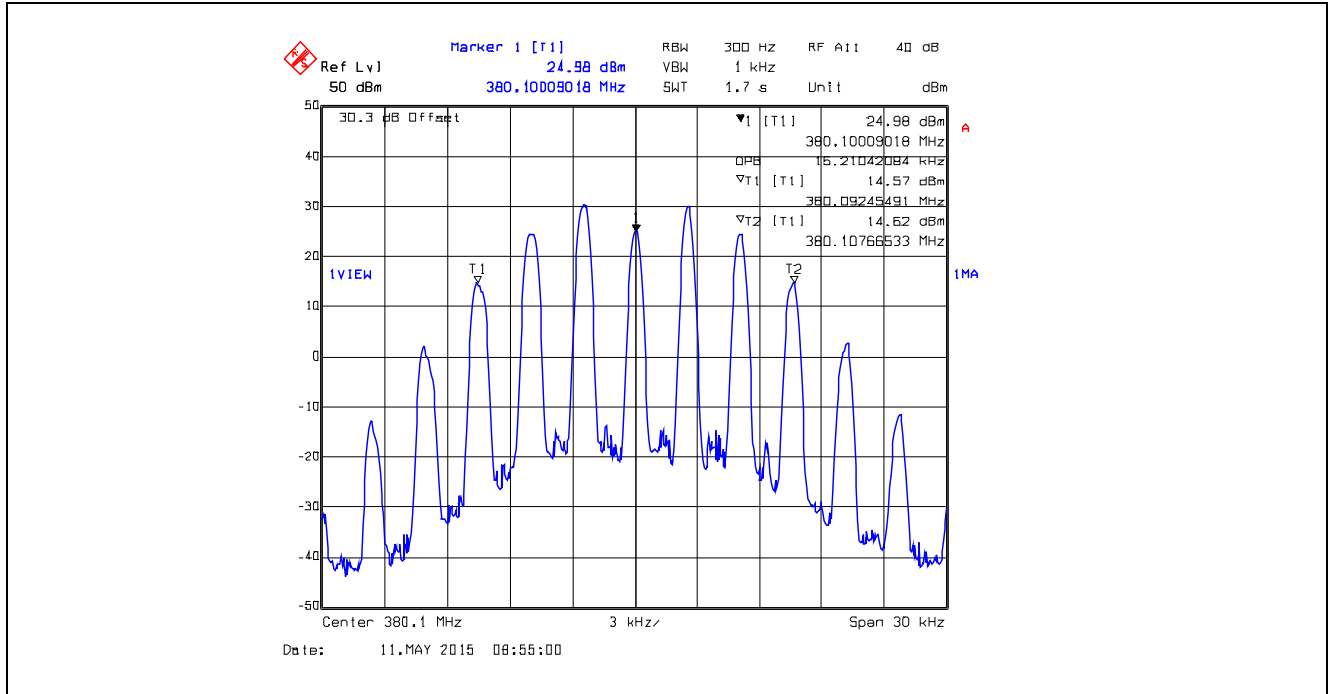

Plot 5.4.4.1.2. 99% Occupied Bandwidth, 25 kHz Channel Spacing, Analog, 390.0 MHz

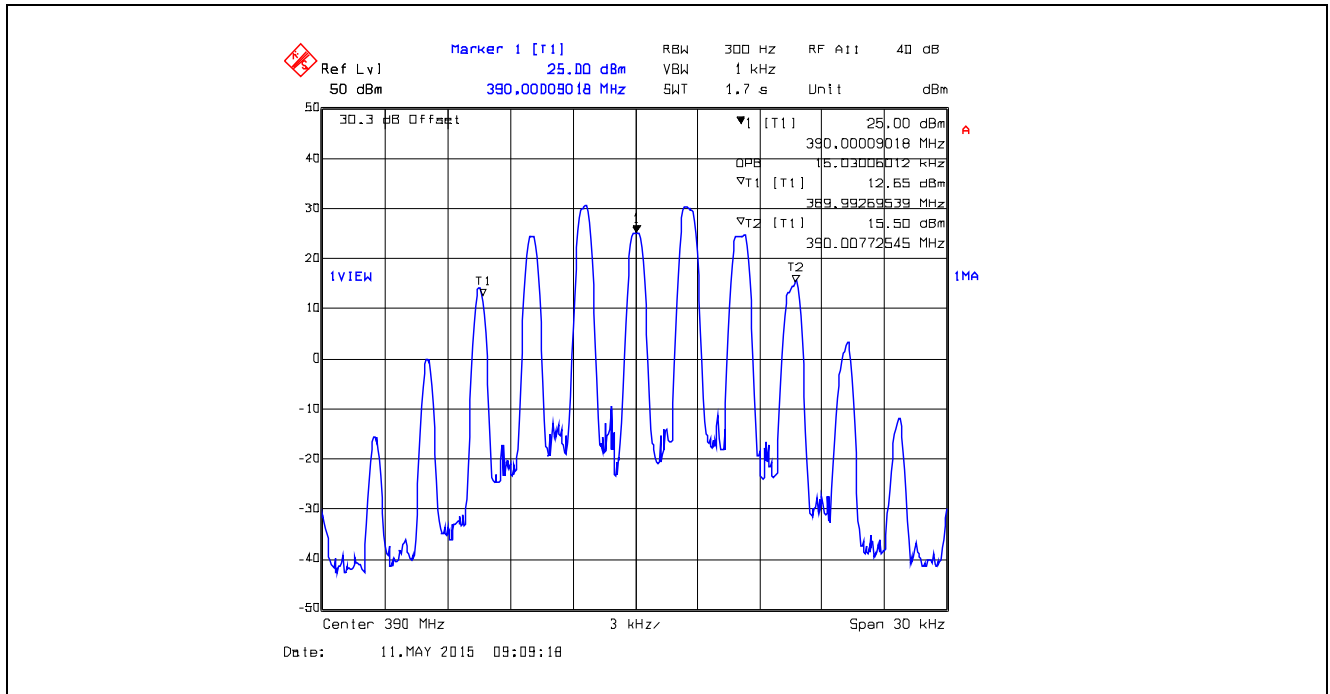

Plot 5.4.4.1.3. 99% Occupied Bandwidth, 25 kHz Channel Spacing, Analog, 399.9 MHz

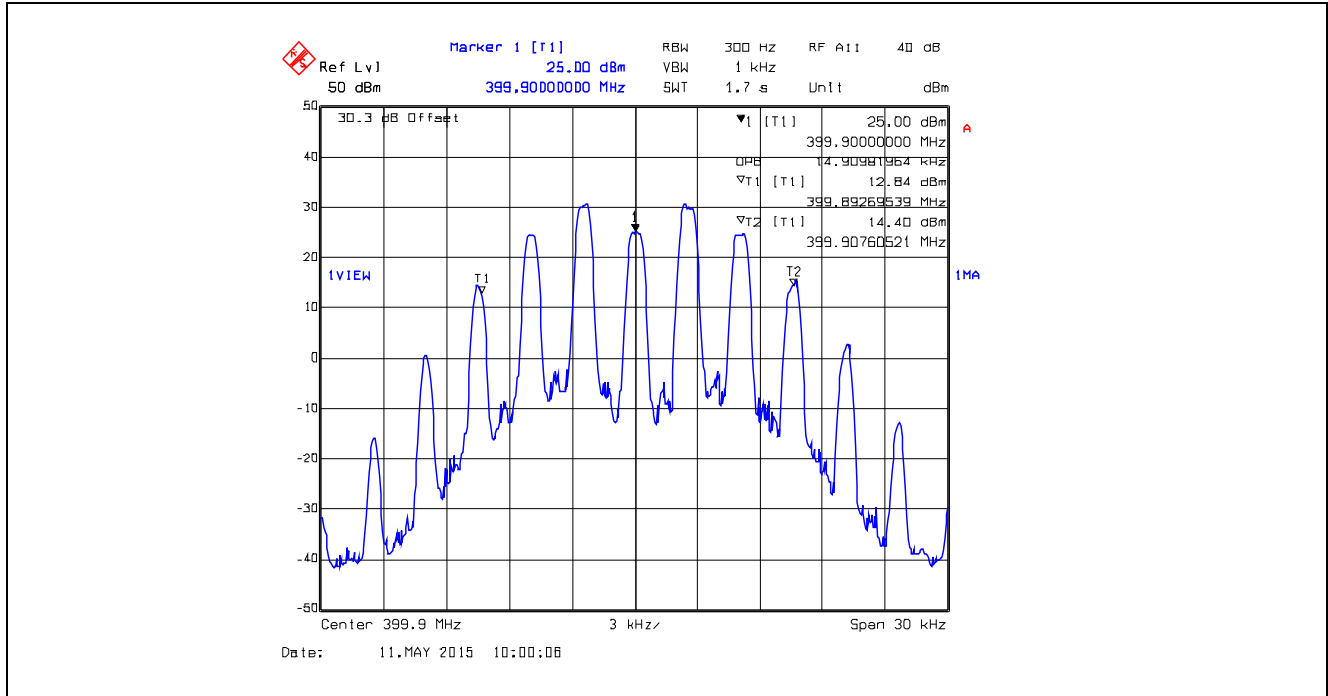

Plot 5.4.4.1.4. 99% Occupied Bandwidth, 25 kHz Channel Spacing, Analog, 406.2 MHz

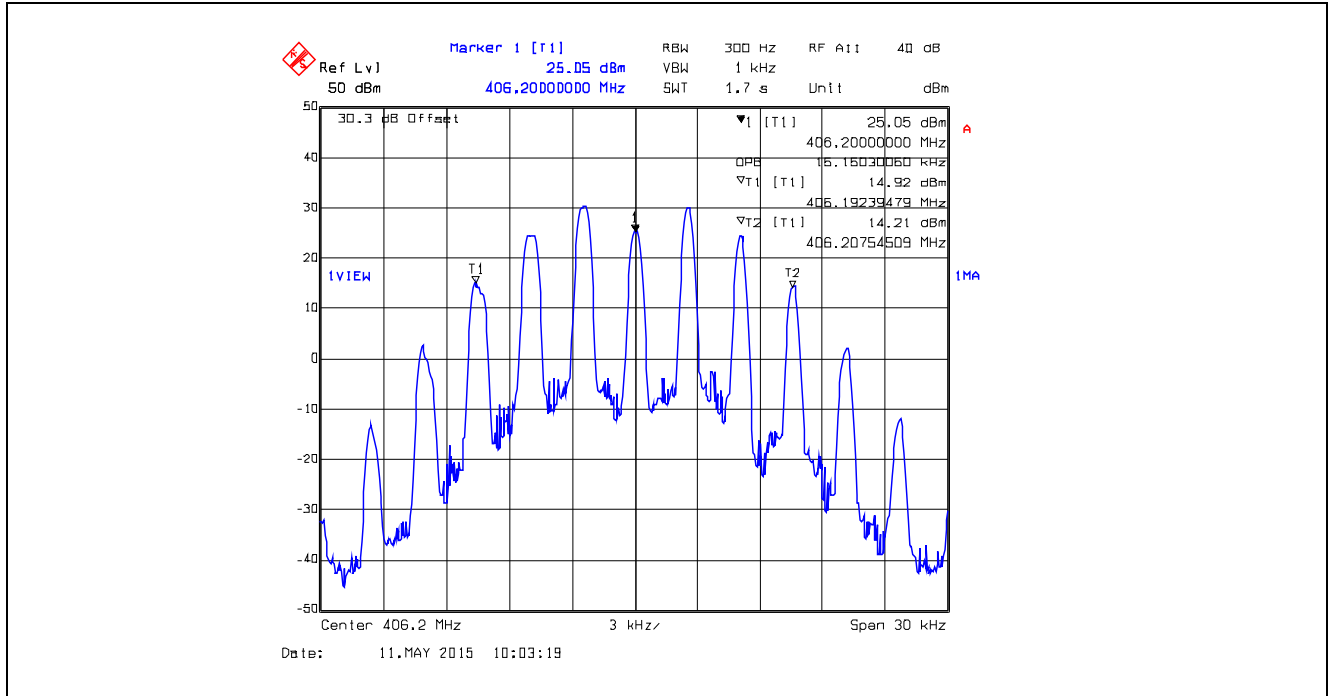

Plot 5.4.4.1.5. 99% Occupied Bandwidth, 25 kHz Channel Spacing, Analog, 415.0 MHz

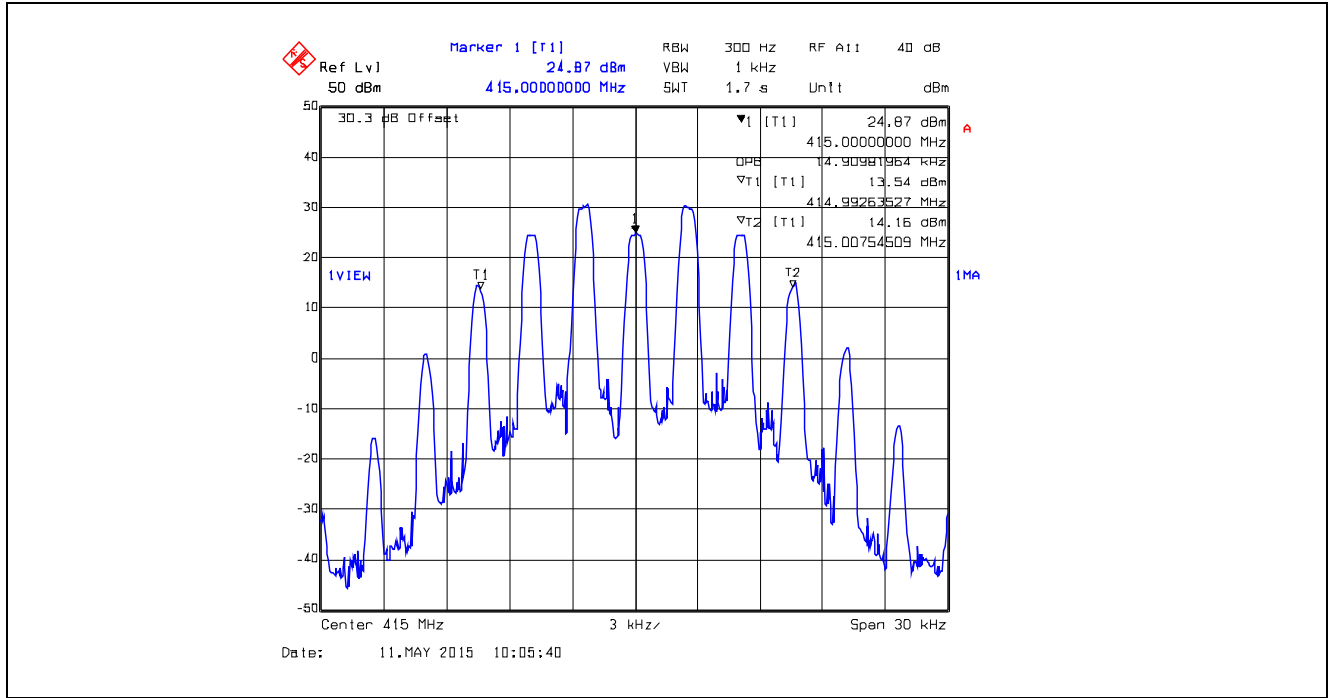

Plot 5.4.4.1.6. 99% Occupied Bandwidth, 25 kHz Channel Spacing, Analog, 429.9 MHz

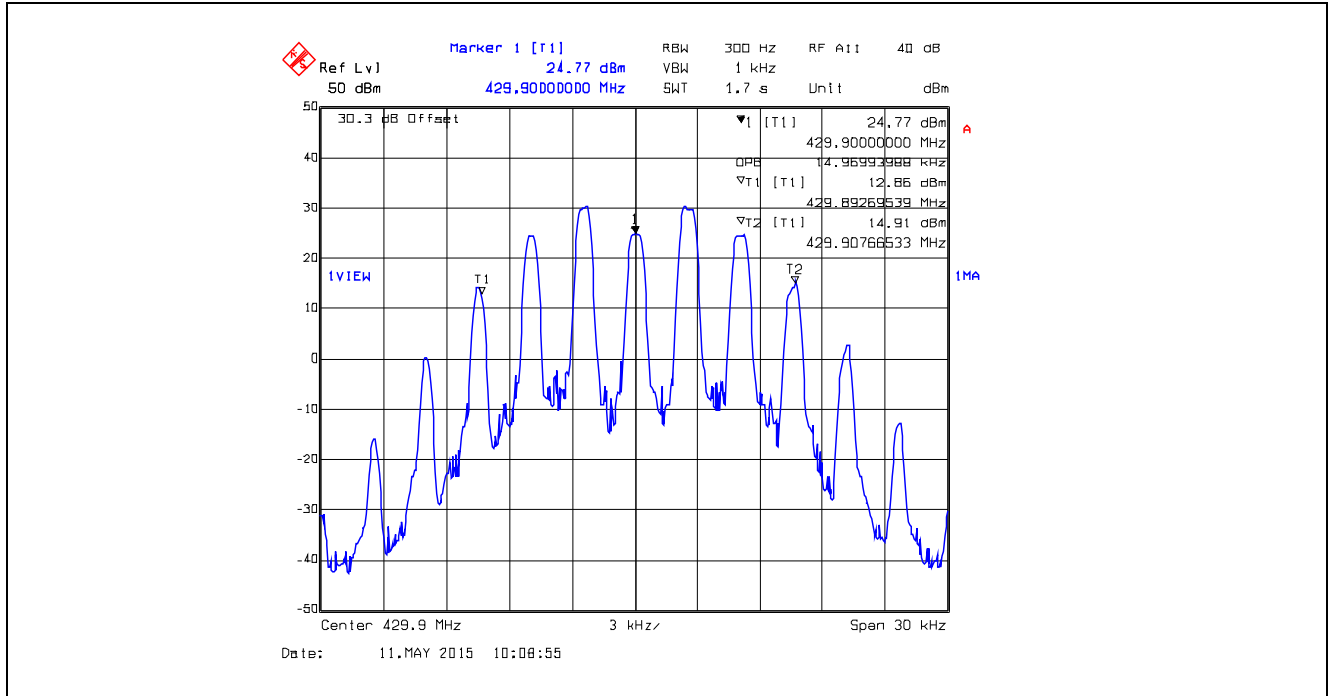

Plot 5.4.4.1.7. 99% Occupied Bandwidth, 25 kHz Channel Spacing, Analog, 450.1 MHz

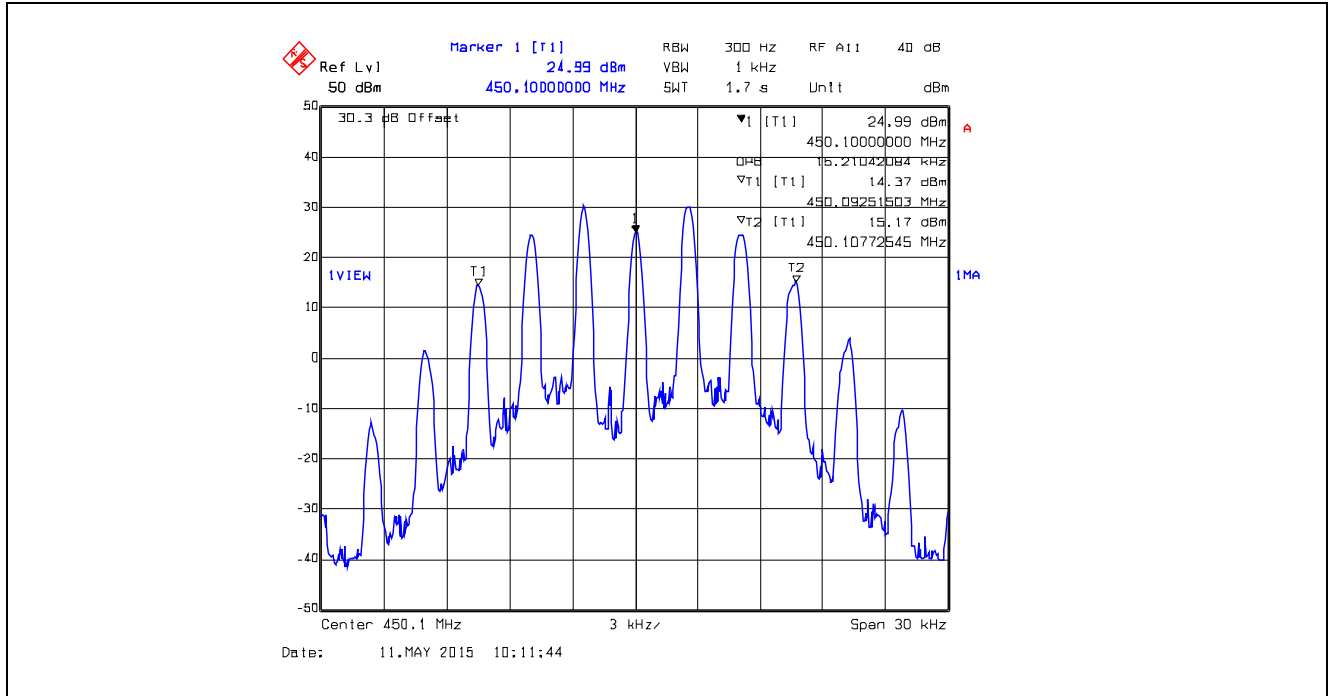

Plot 5.4.4.1.8. 99% Occupied Bandwidth, 25 kHz Channel Spacing, Analog, 470.0 MHz

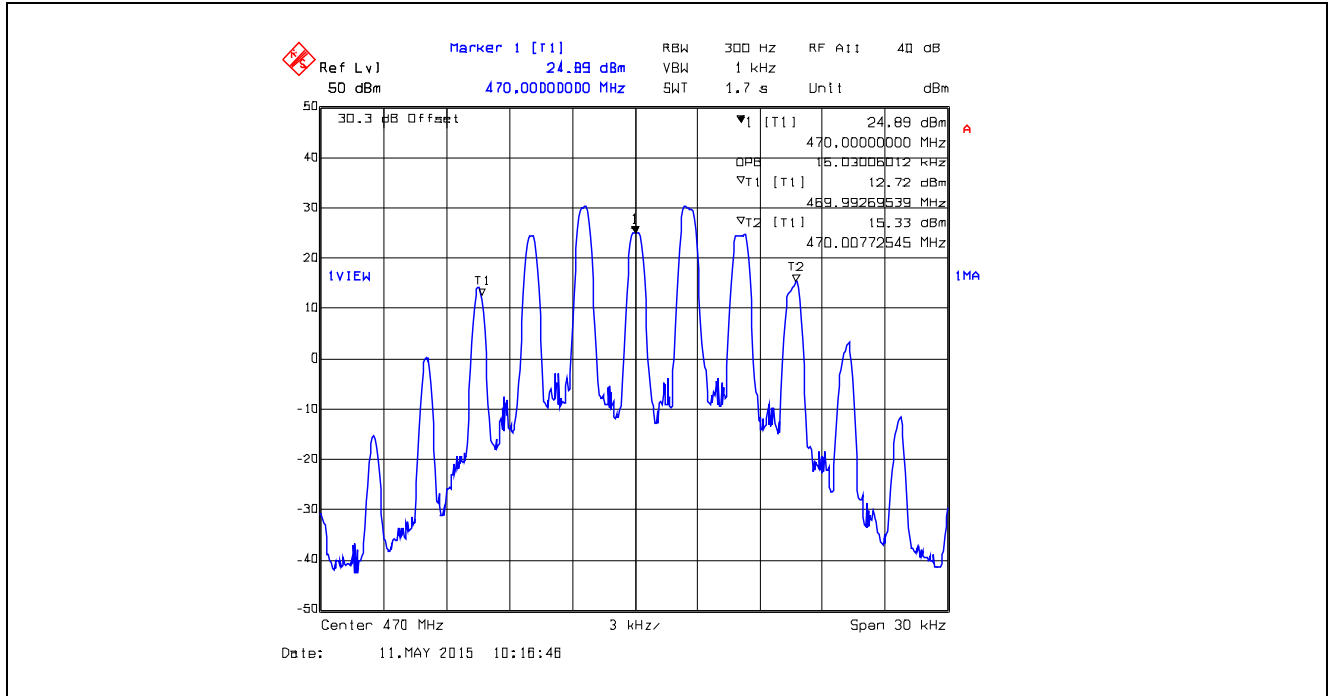

Plot 5.4.4.1.9. 99% Occupied Bandwidth, 25 kHz Channel Spacing, Analog, 511.9 MHz

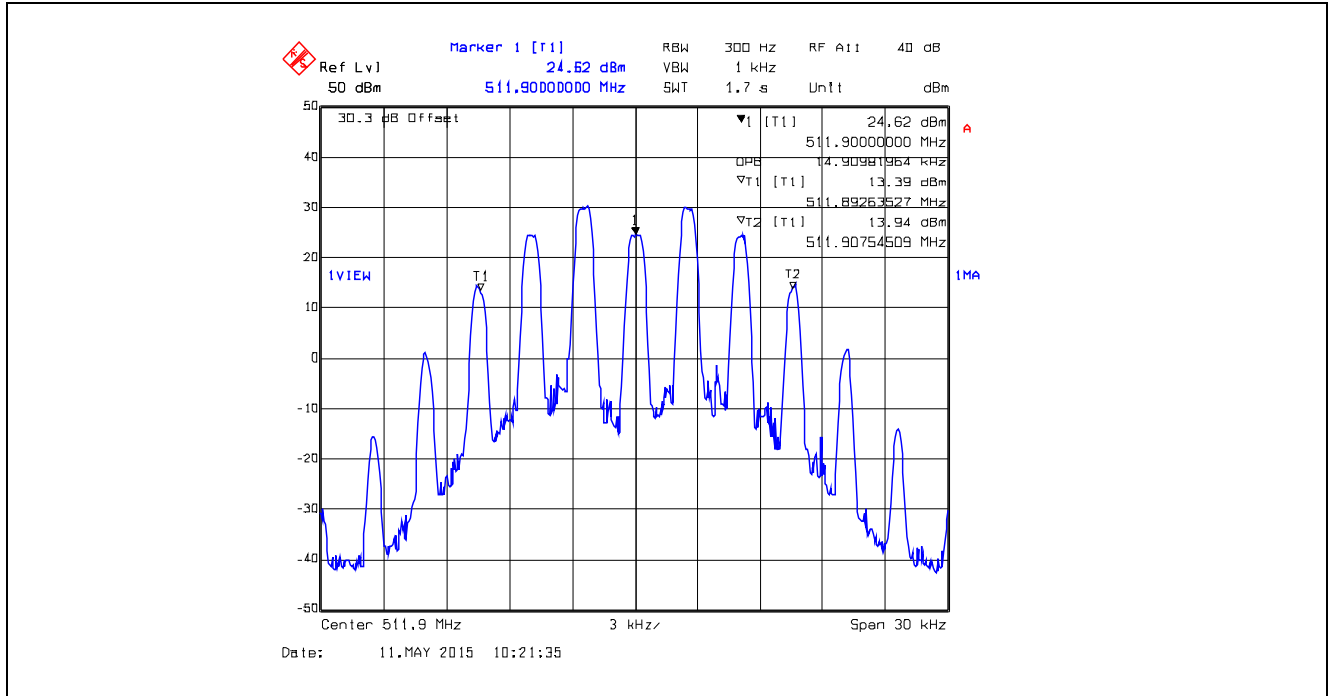

Plot 5.4.4.1.10. 99% Occupied Bandwidth, 25 kHz Channel Spacing, Digital 19.2 kbps, 381.1 MHz

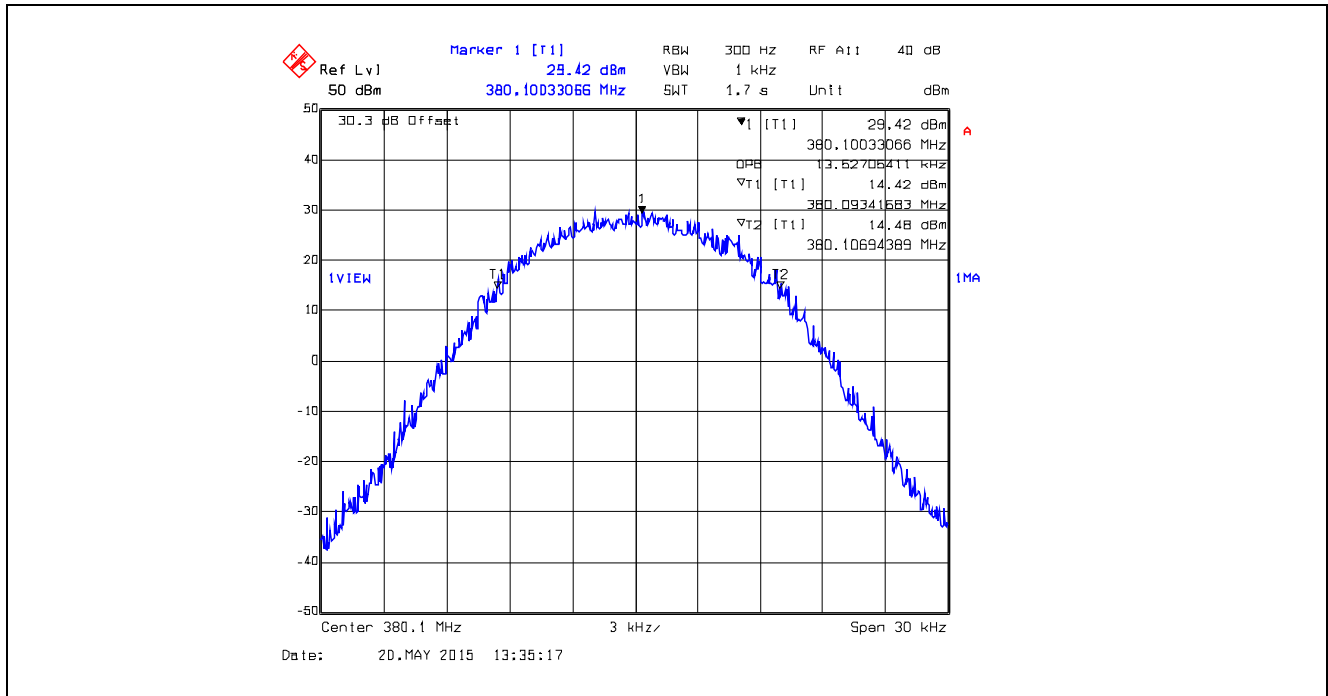

Plot 5.4.4.1.11. 99% Occupied Bandwidth, 25 kHz Channel Spacing, Digital 19.2 kbps, 390.0 MHz

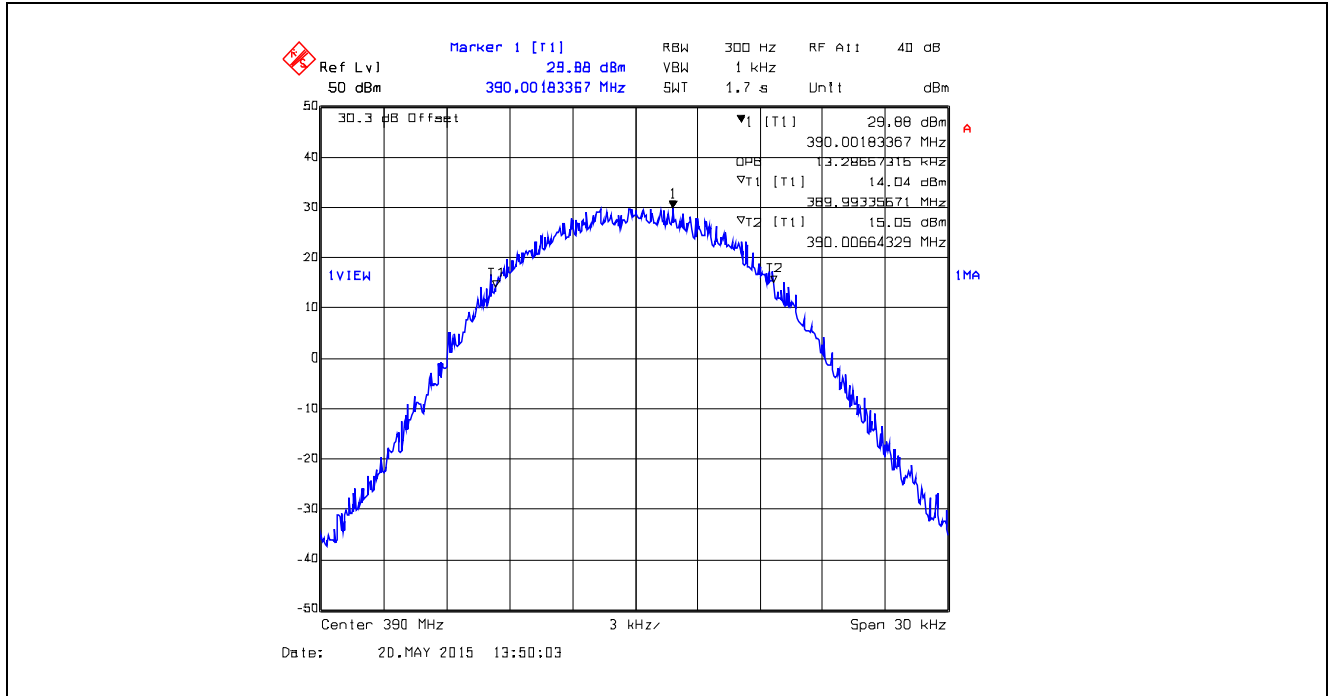

Plot 5.4.4.1.12. 99% Occupied Bandwidth, 25 kHz Channel Spacing, Digital 19.2 kbps, 399.9 MHz

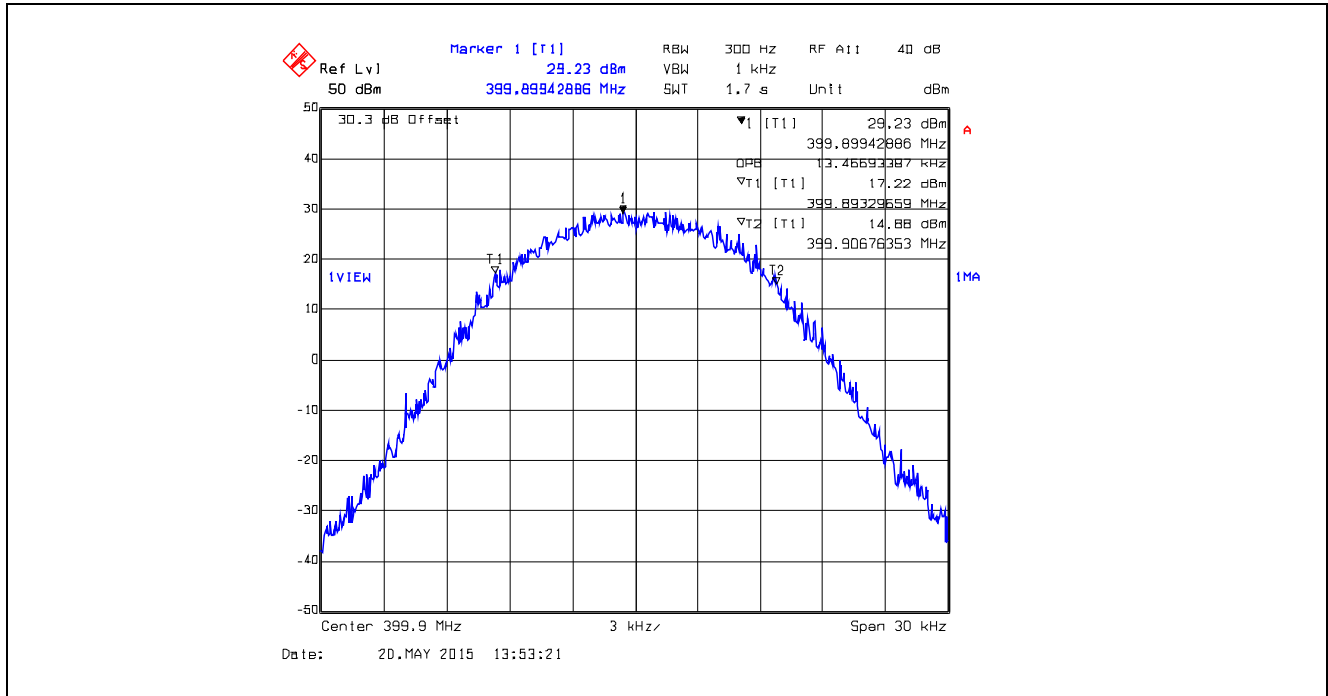

Plot 5.4.4.1.13. 99% Occupied Bandwidth, 25 kHz Channel Spacing, Digital 19.2 kbps, 406.2 MHz

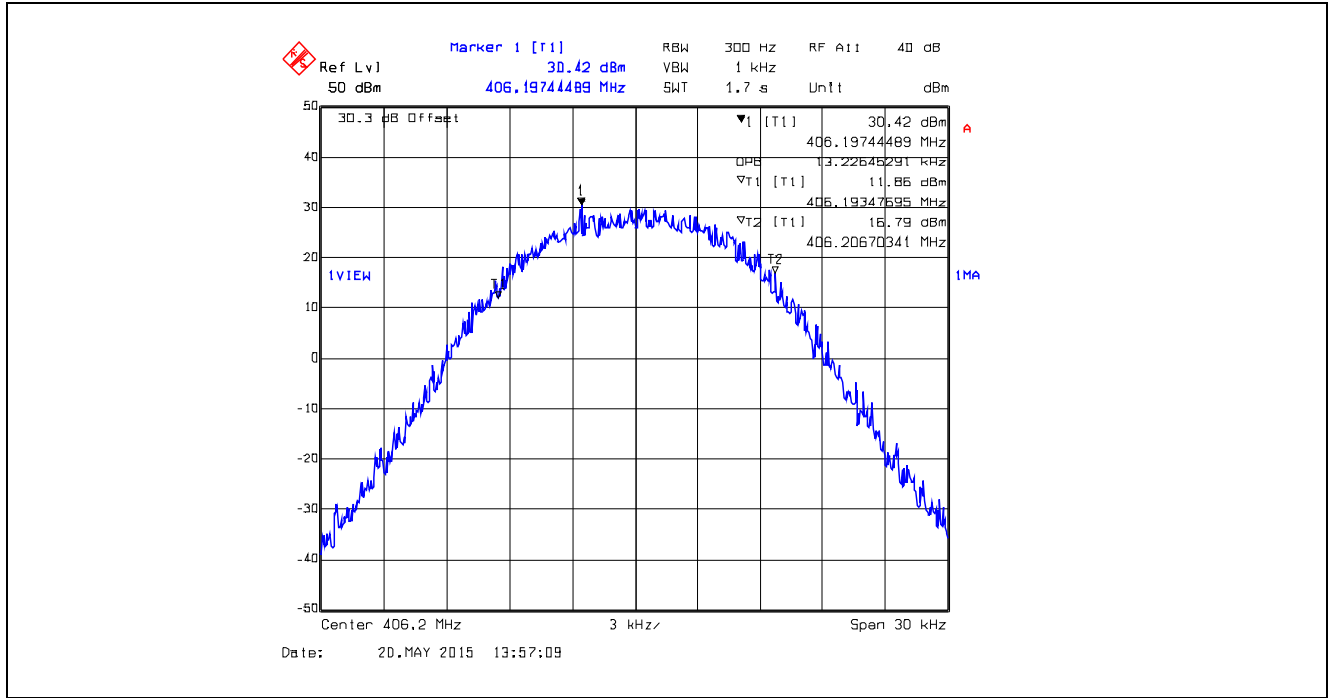

Plot 5.4.4.1.14. 99% Occupied Bandwidth, 25 kHz Channel Spacing, Digital 19.2 kbps, 415.0 MHz

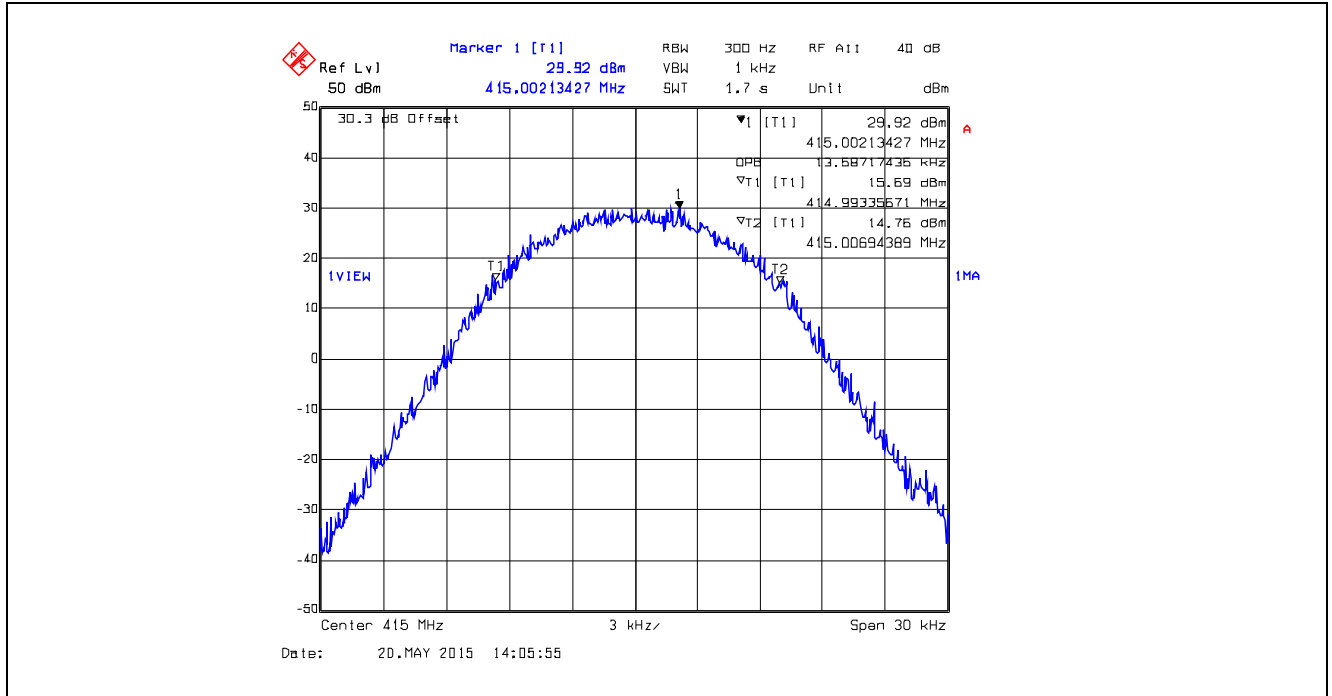

ULTRATECH GROUP OF LABS

3000 Bristol Circle, Oakville, Ontario, Canada L6H 6G4
 Tel. #: 905-829-1570, Fax. #: 905-829-8050, Email: vic@ultratech-labs.com, Website: <http://www.ultratech-labs.com>

File #: 15FSG141_FCC90
 July 8, 2015

All test results contained in this engineering test report are traceable to National Institute of Standards and Technology (NIST)

Plot 5.4.4.1.15. 99% Occupied Bandwidth, 25 kHz Channel Spacing, Digital 19.2 kbps, 429.9 MHz

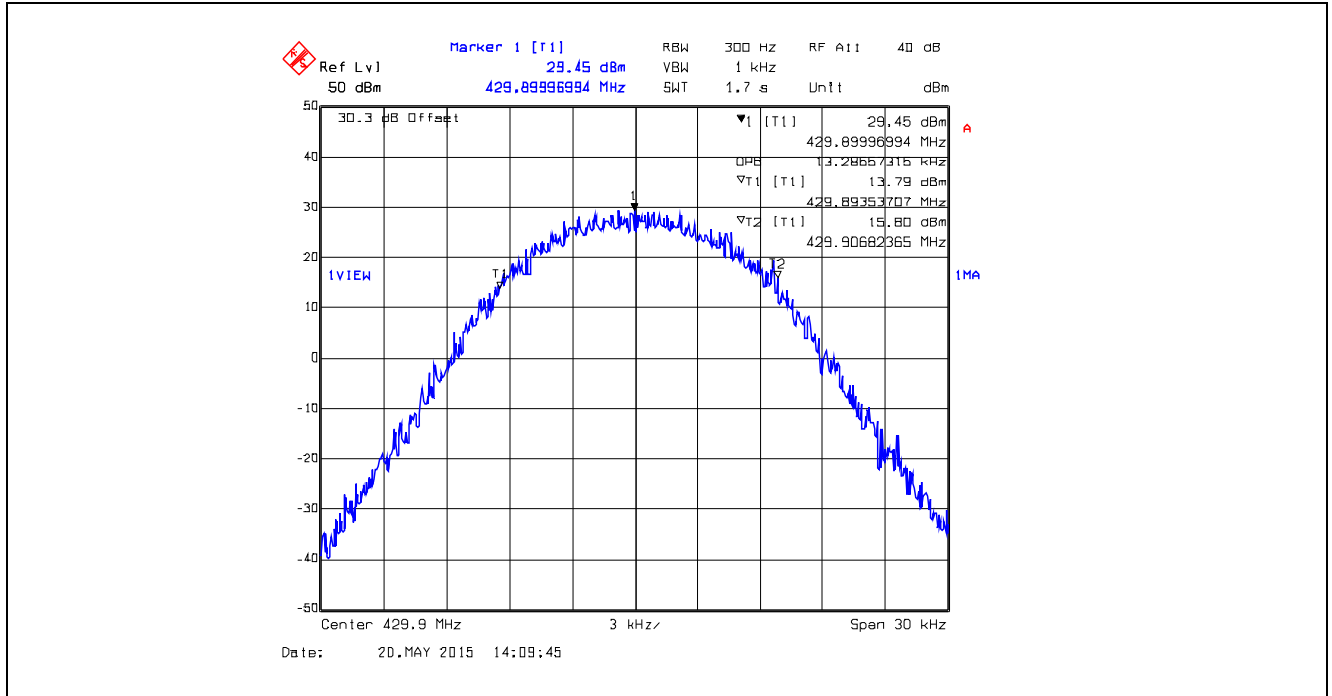

Plot 5.4.4.1.16. 99% Occupied Bandwidth, 25 kHz Channel Spacing, Digital 19.2 kbps, 450.1 MHz

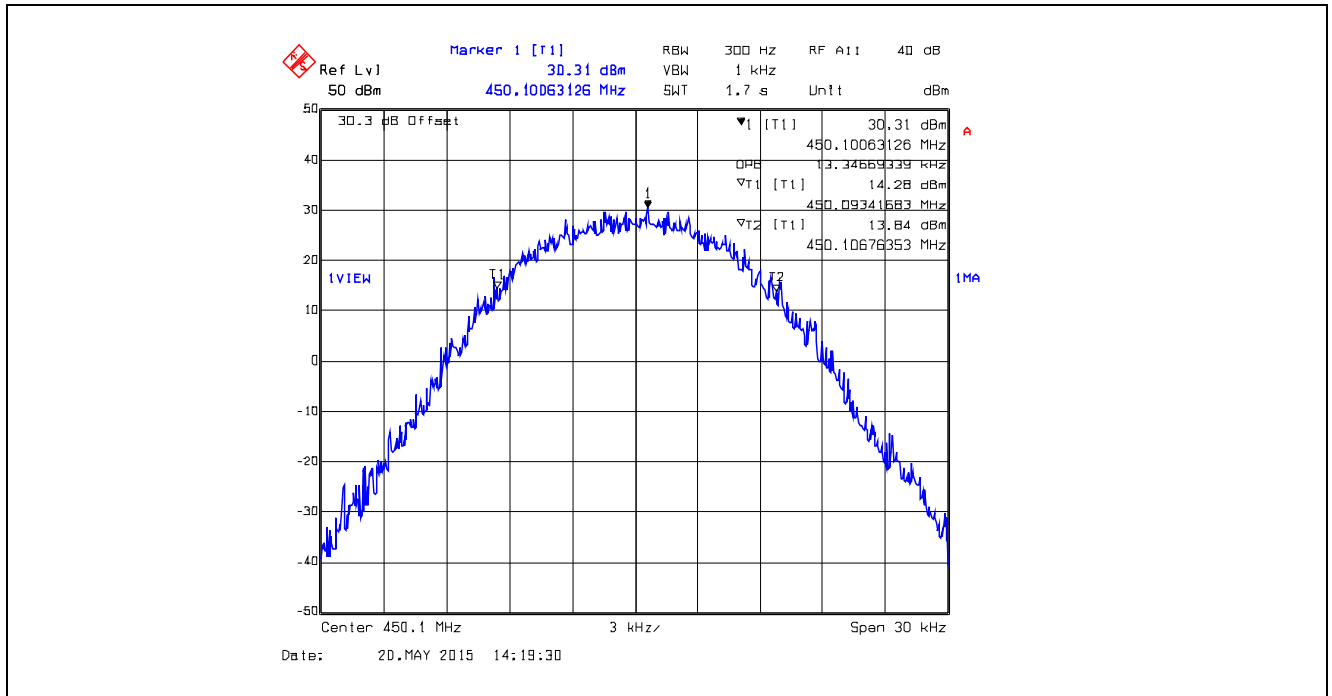

Plot 5.4.4.1.17. 99% Occupied Bandwidth, 25 kHz Channel Spacing, Digital 19.2 kbps, 470.0 MHz

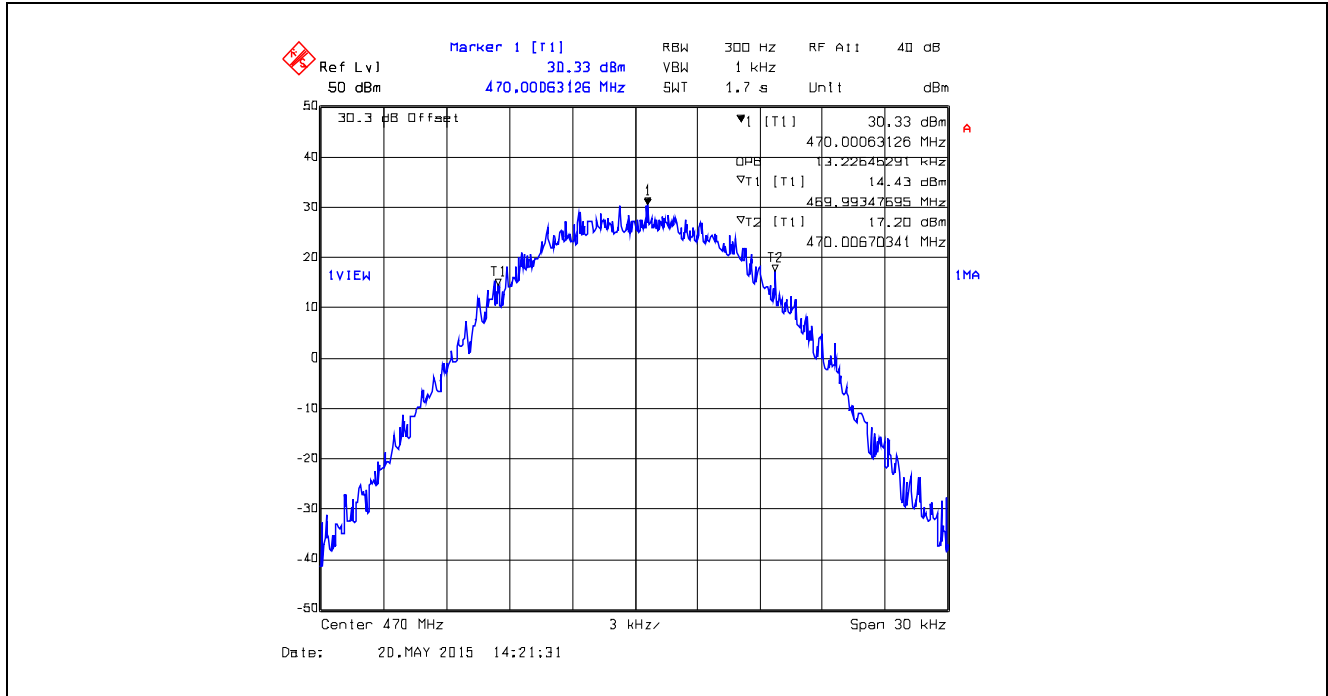

Plot 5.4.4.1.18. 99% Occupied Bandwidth, 25 kHz Channel Spacing, Digital 19.2 kbps, 511.9 MHz

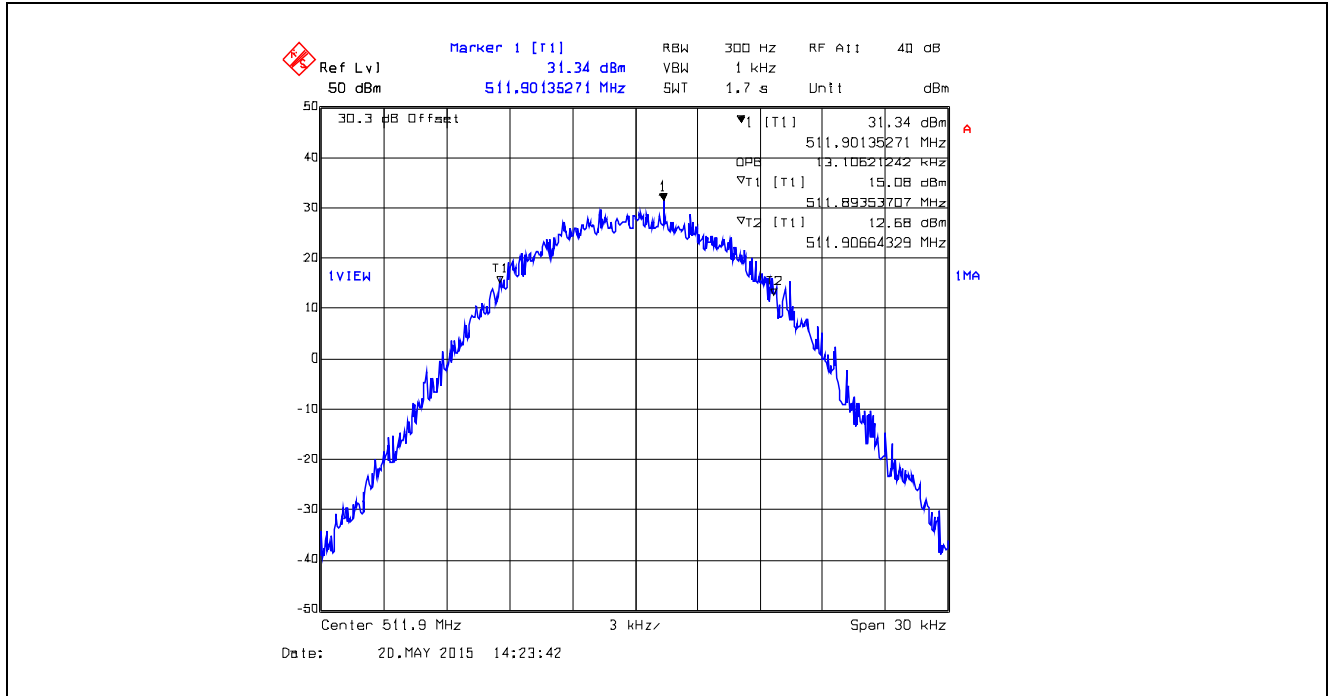

Plot 5.4.4.1.19. 99% Occupied Bandwidth, 12.5 kHz Channel Spacing, Analog, 381.1 MHz

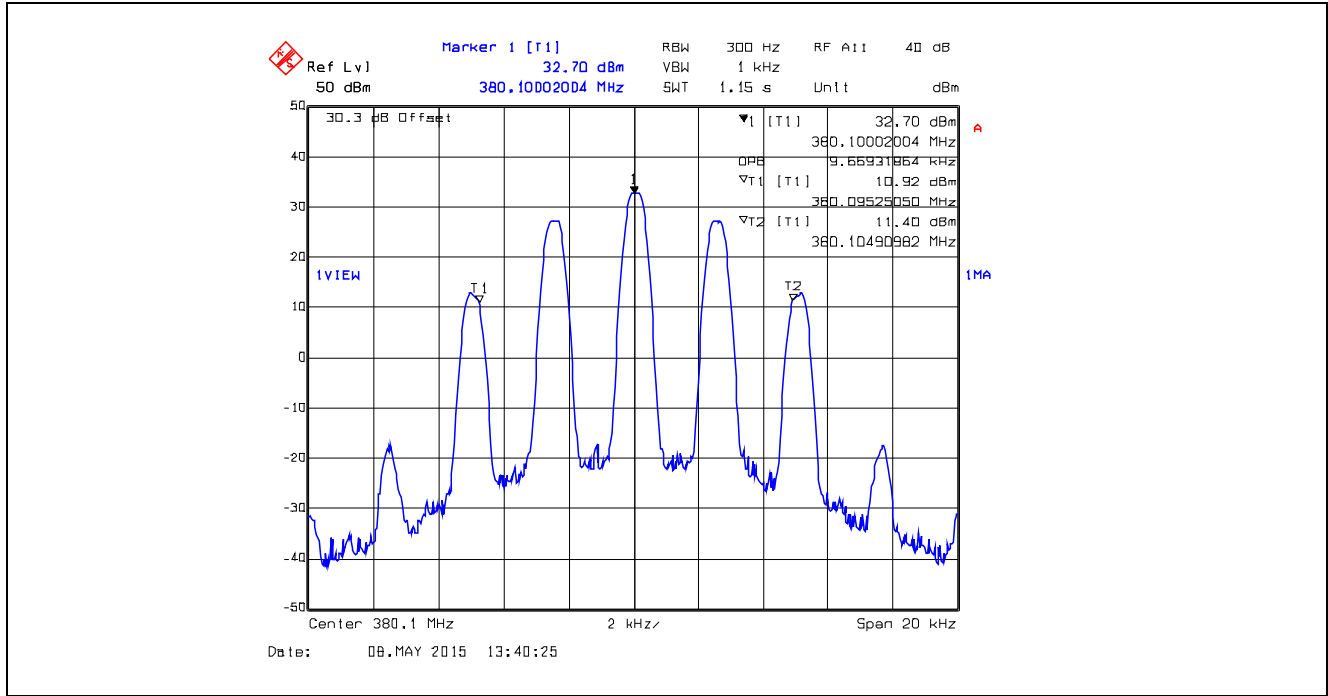

Plot 5.4.4.1.20. 99% Occupied Bandwidth, 12.5 kHz Channel Spacing, Analog, 390.0 MHz

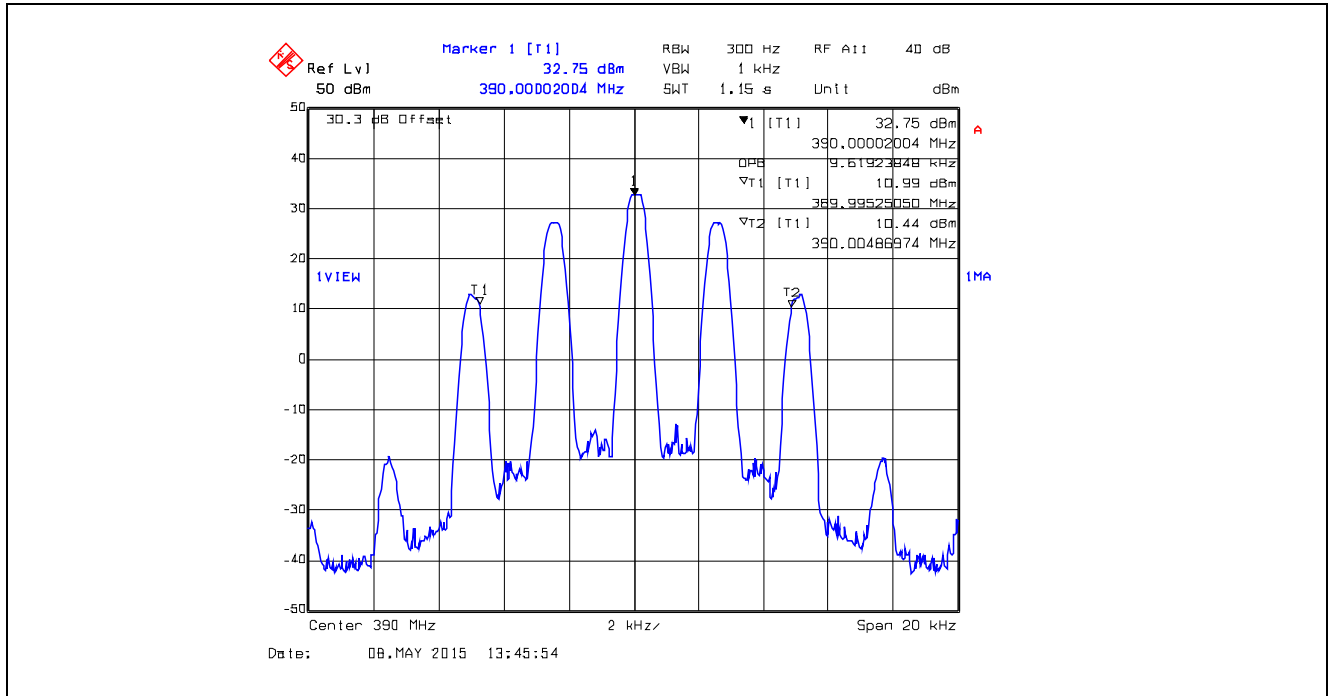

Plot 5.4.4.1.21. 99% Occupied Bandwidth, 12.5 kHz Channel Spacing, Analog, 399.9 MHz

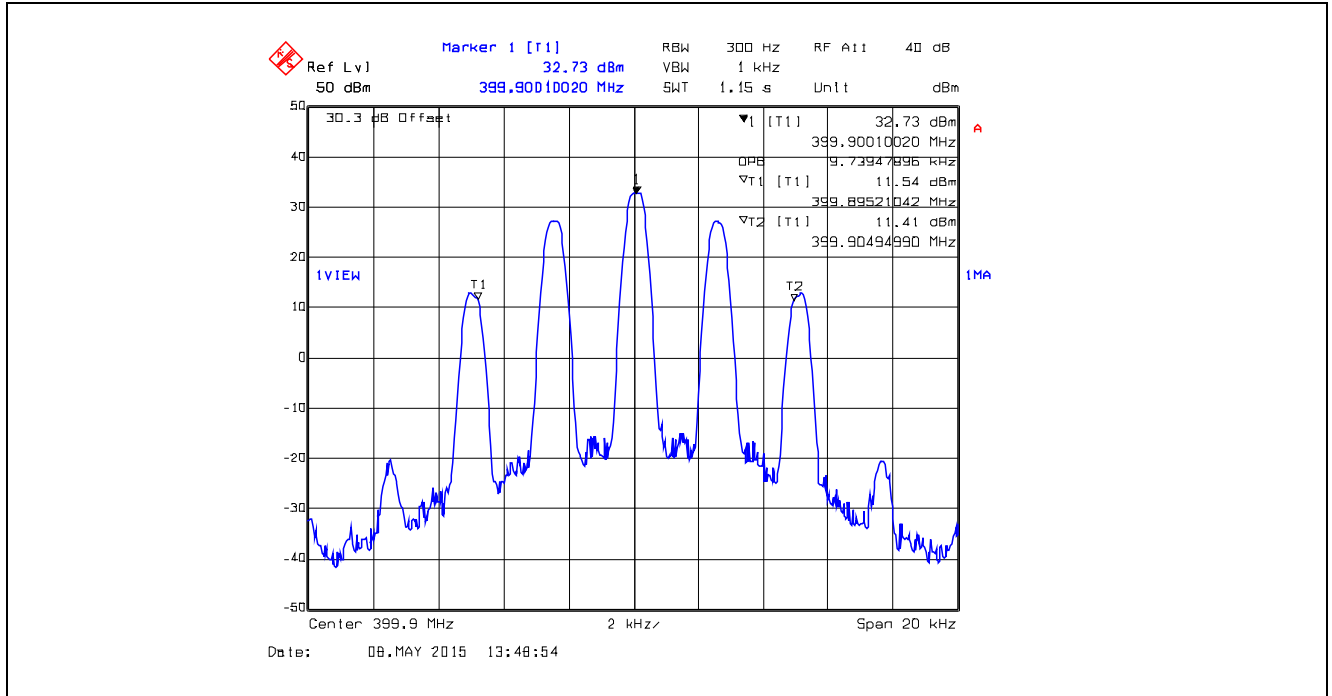

Plot 5.4.4.1.22. 99% Occupied Bandwidth, 12.5 kHz Channel Spacing, Analog, 406.2 MHz

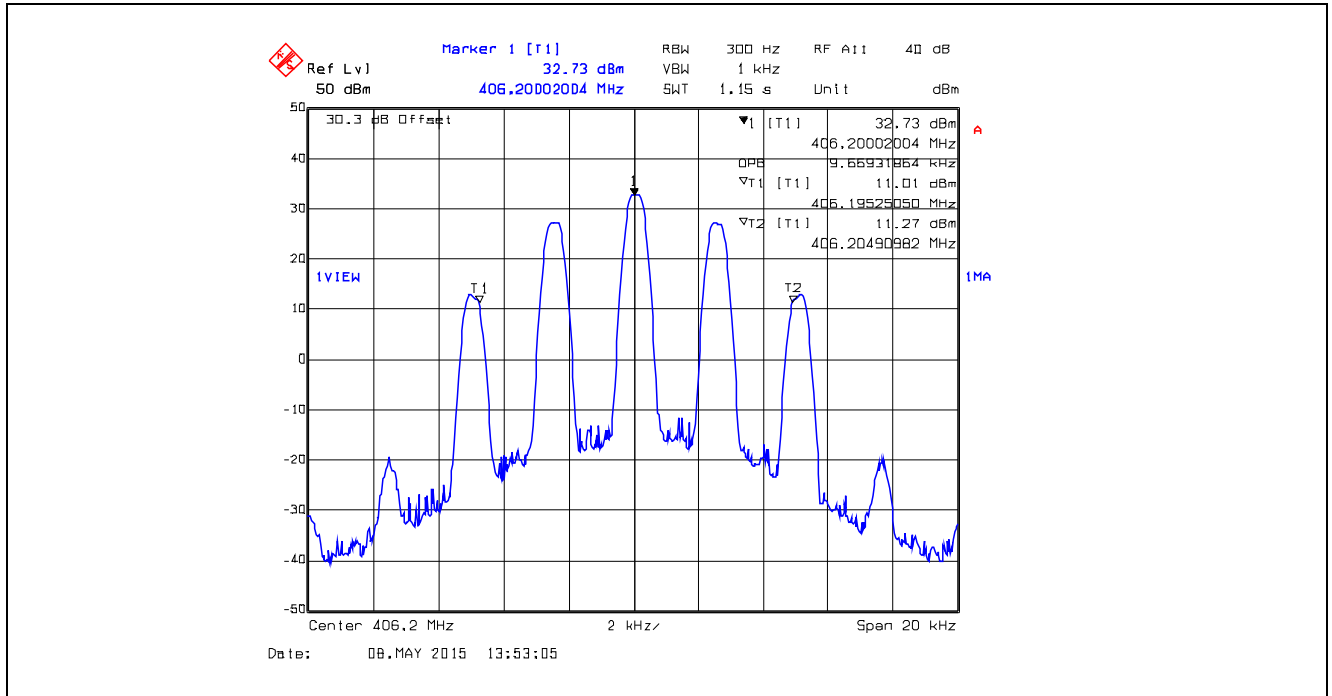

Plot 5.4.4.1.23. 99% Occupied Bandwidth, 12.5 kHz Channel Spacing, Analog, 415.0 MHz

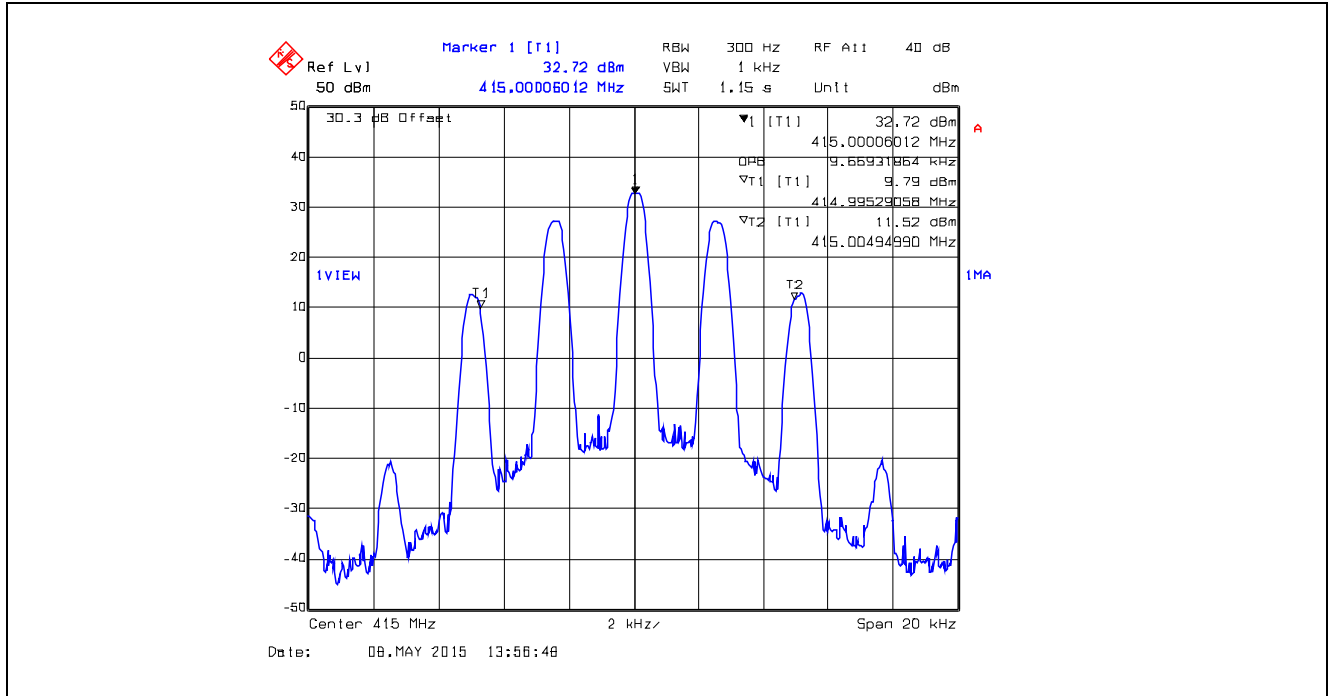

Plot 5.4.4.1.24. 99% Occupied Bandwidth, 12.5 kHz Channel Spacing, Analog, 429.9 MHz

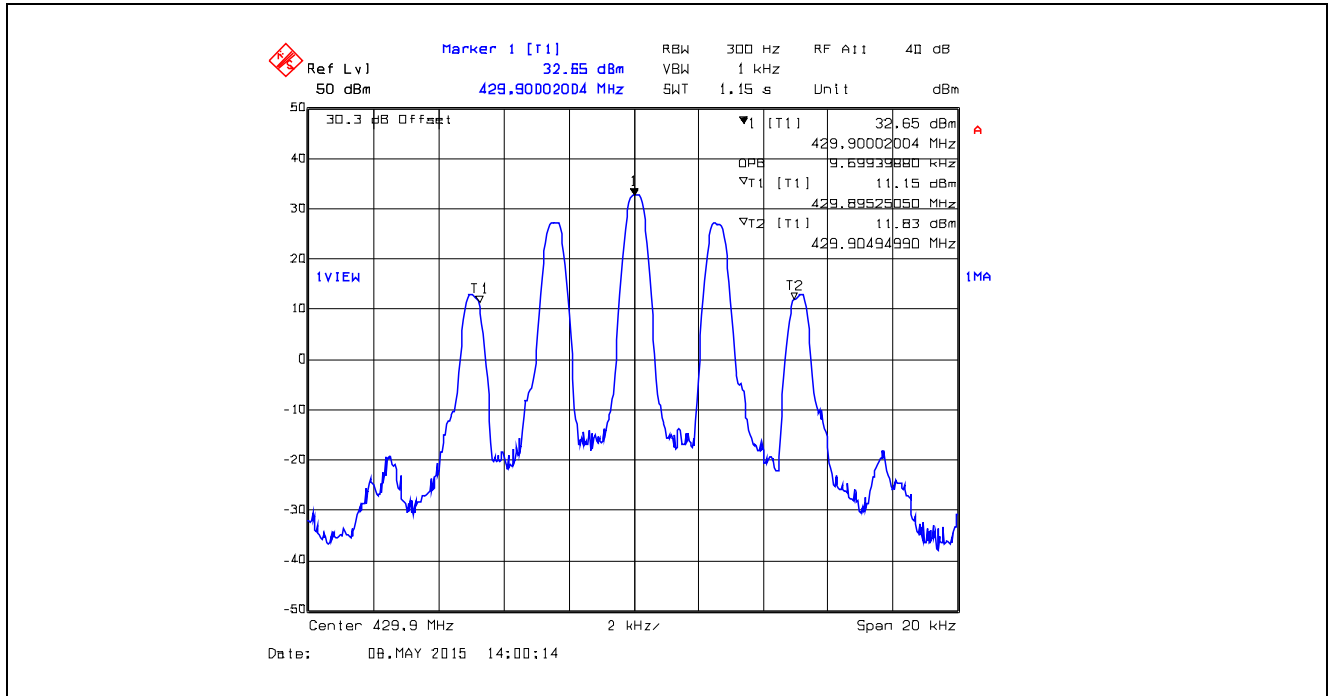

Plot 5.4.4.1.25. 99% Occupied Bandwidth, 12.5 kHz Channel Spacing, Analog, 450.1 MHz

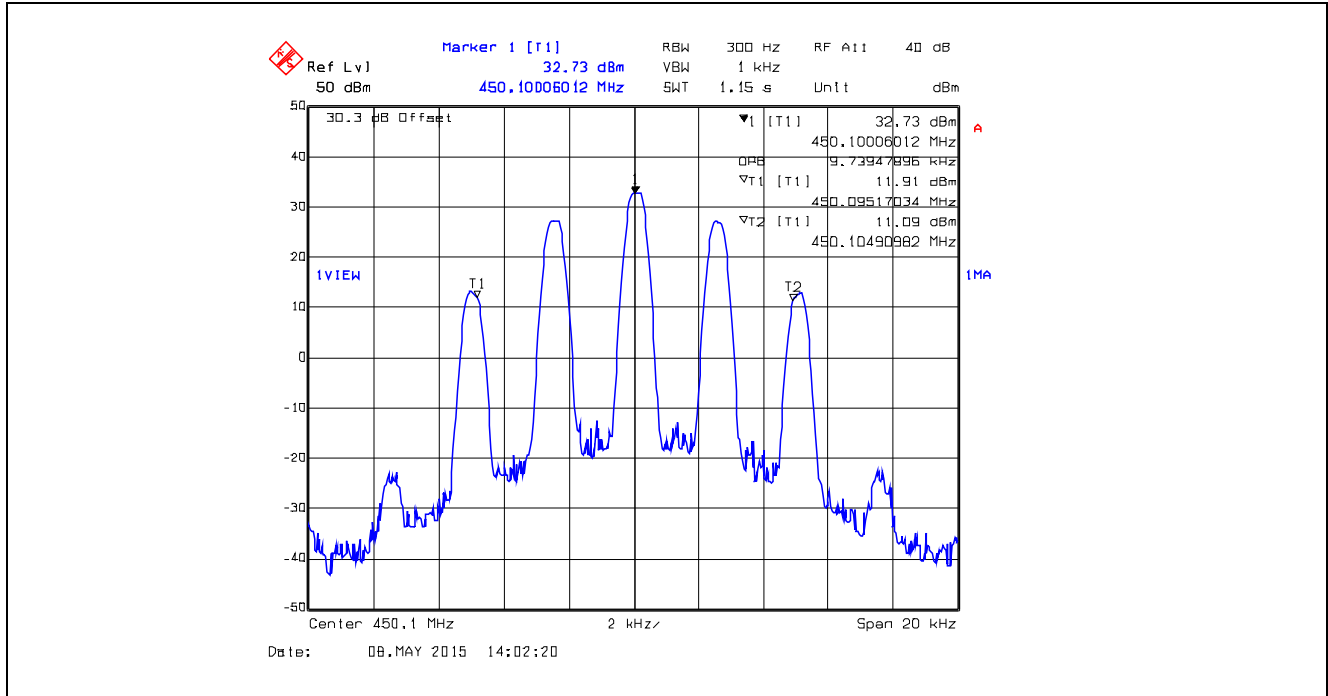

Plot 5.4.4.1.26. 99% Occupied Bandwidth, 12.5 kHz Channel Spacing, Analog, 470.0 MHz

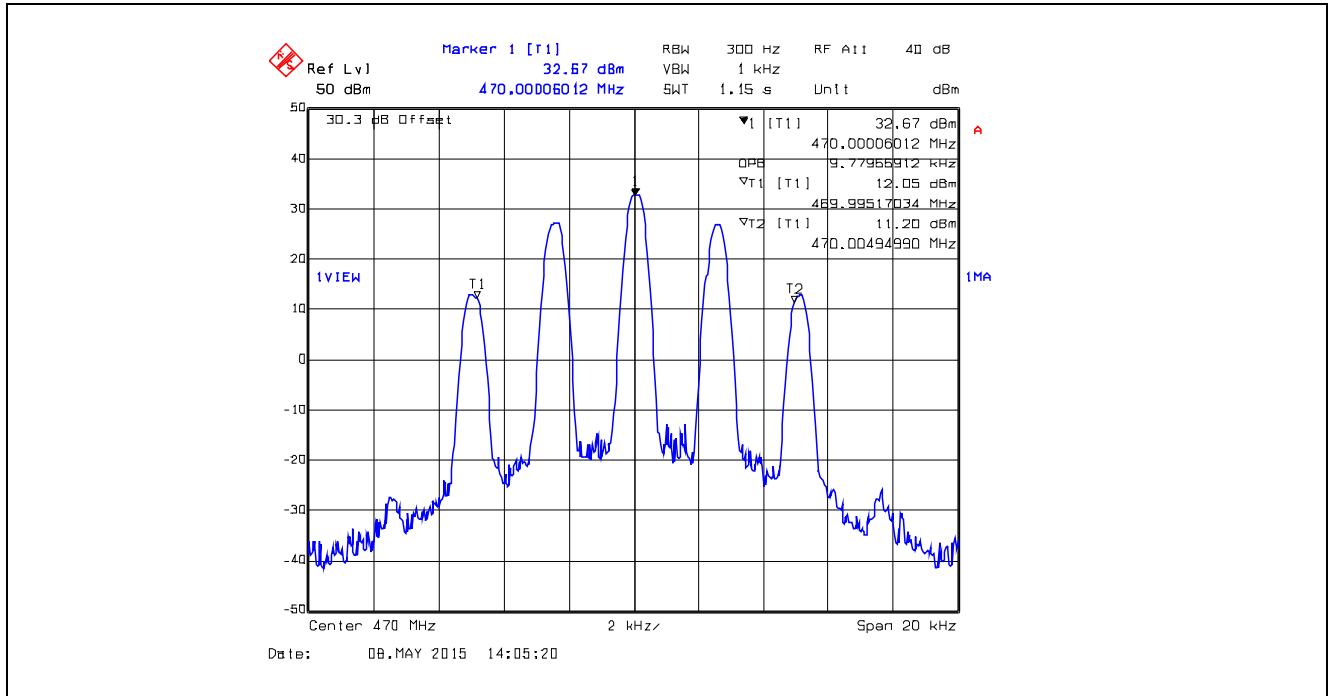

Plot 5.4.4.1.27. 99% Occupied Bandwidth, 12.5 kHz Channel Spacing, Analog, 511.9 MHz

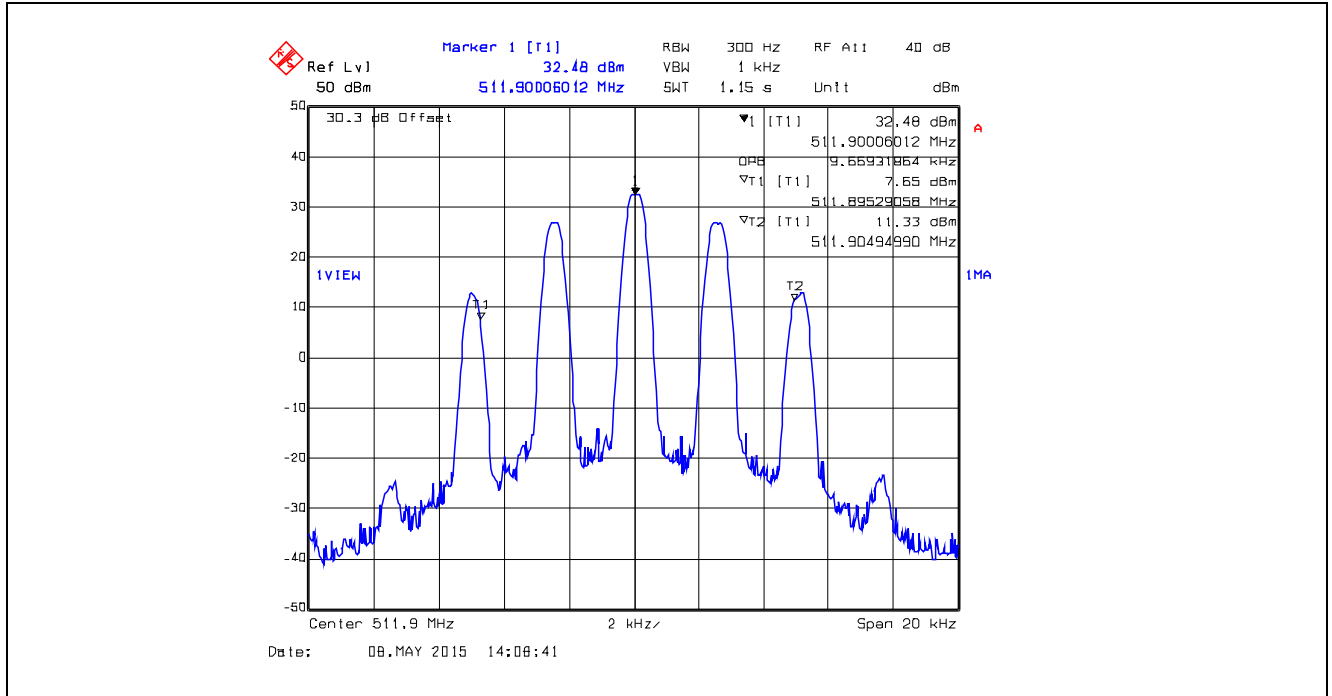

Plot 5.4.4.1.28. 99% Occupied Bandwidth, 12.5 kHz Channel Spacing, Digital 9.6 kbps, 381.1 MHz

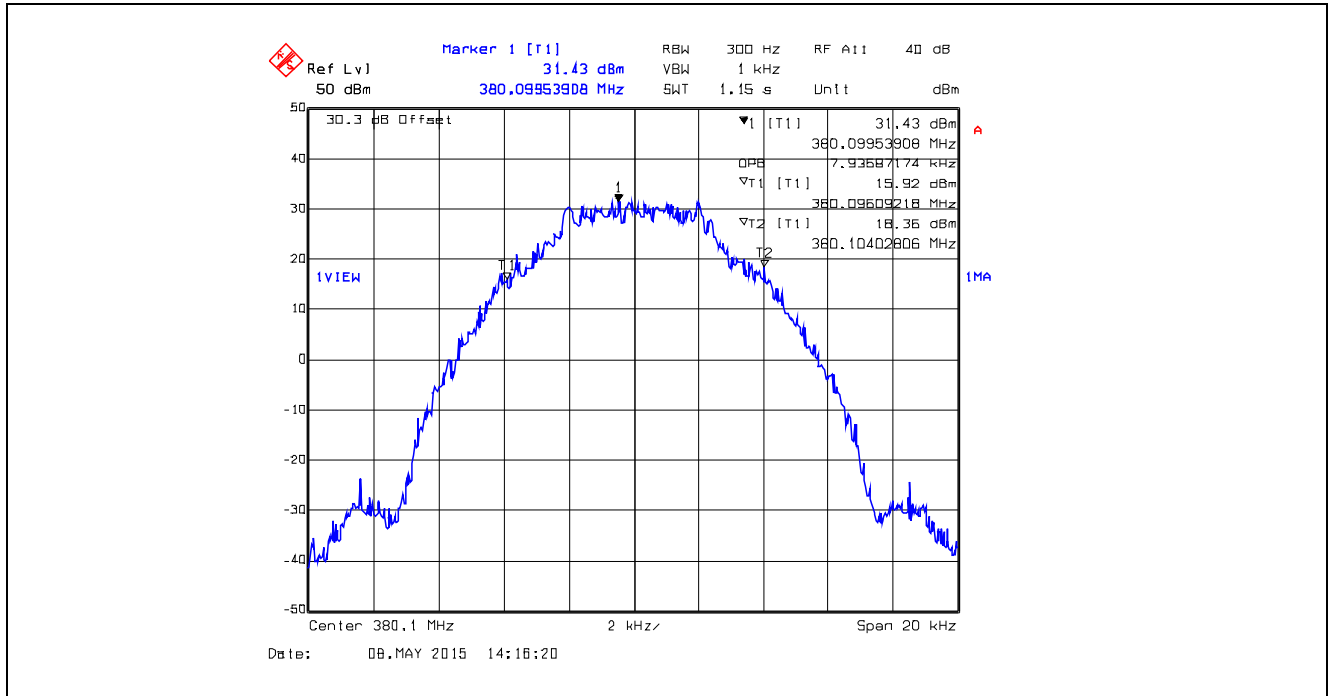

ULTRATECH GROUP OF LABS

3000 Bristol Circle, Oakville, Ontario, Canada L6H 6G4
 Tel. #: 905-829-1570, Fax. #: 905-829-8050, Email: vic@ultratech-labs.com, Website: <http://www.ultratech-labs.com>

File #: 15FSG141_FCC90
 July 8, 2015

All test results contained in this engineering test report are traceable to National Institute of Standards and Technology (NIST)

Plot 5.4.4.1.29. 99% Occupied Bandwidth, 12.5 kHz Channel Spacing, Digital 9.6 kbps, 390.0 MHz

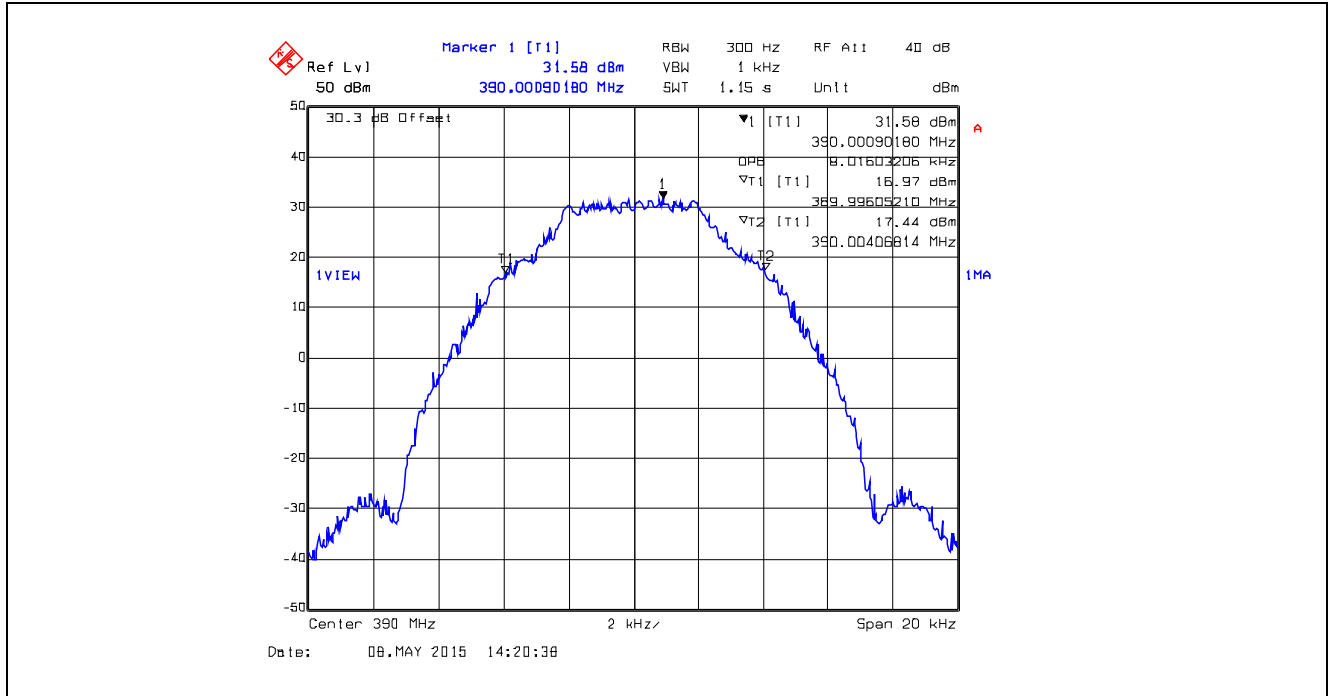

Plot 5.4.4.1.30. 99% Occupied Bandwidth, 12.5 kHz Channel Spacing, Digital 9.6 kbps, 399.9 MHz

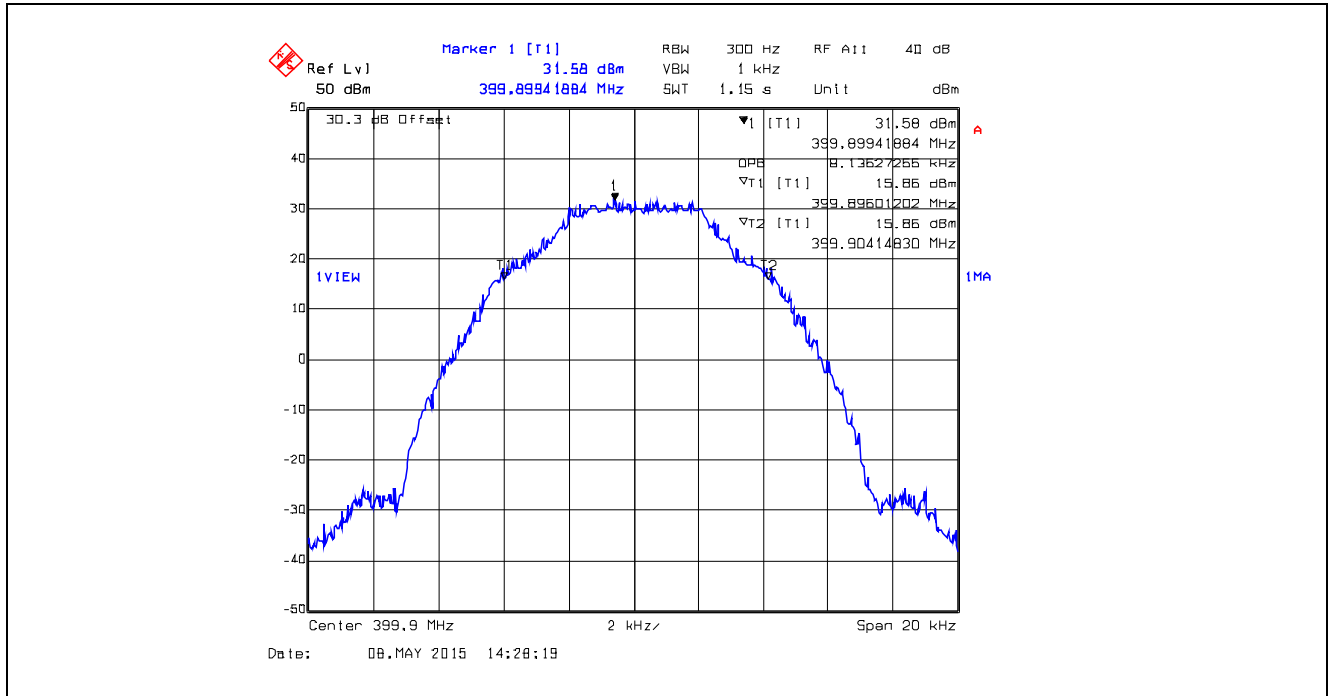

Plot 5.4.4.1.31. 99% Occupied Bandwidth, 12.5 kHz Channel Spacing, Digital 9.6 kbps, 406.2 MHz

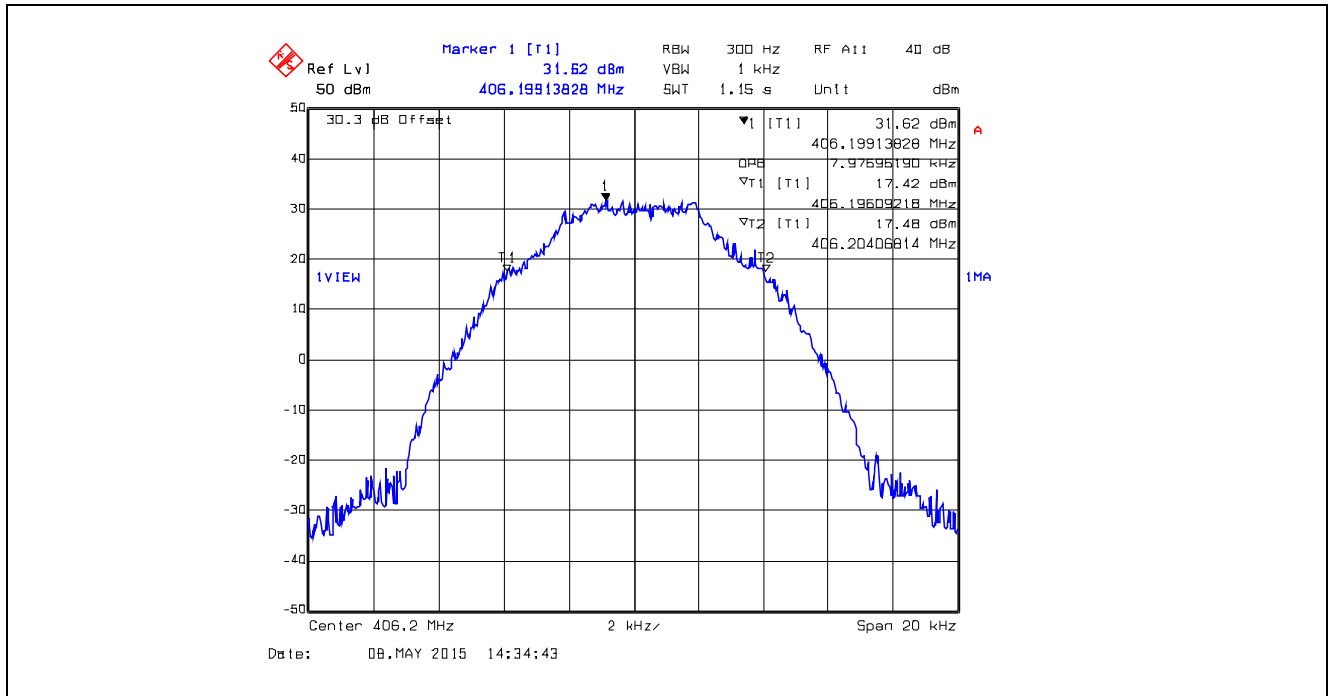

Plot 5.4.4.1.32. 99% Occupied Bandwidth, 12.5 kHz Channel Spacing, Digital 9.6 kbps, 415.0 MHz

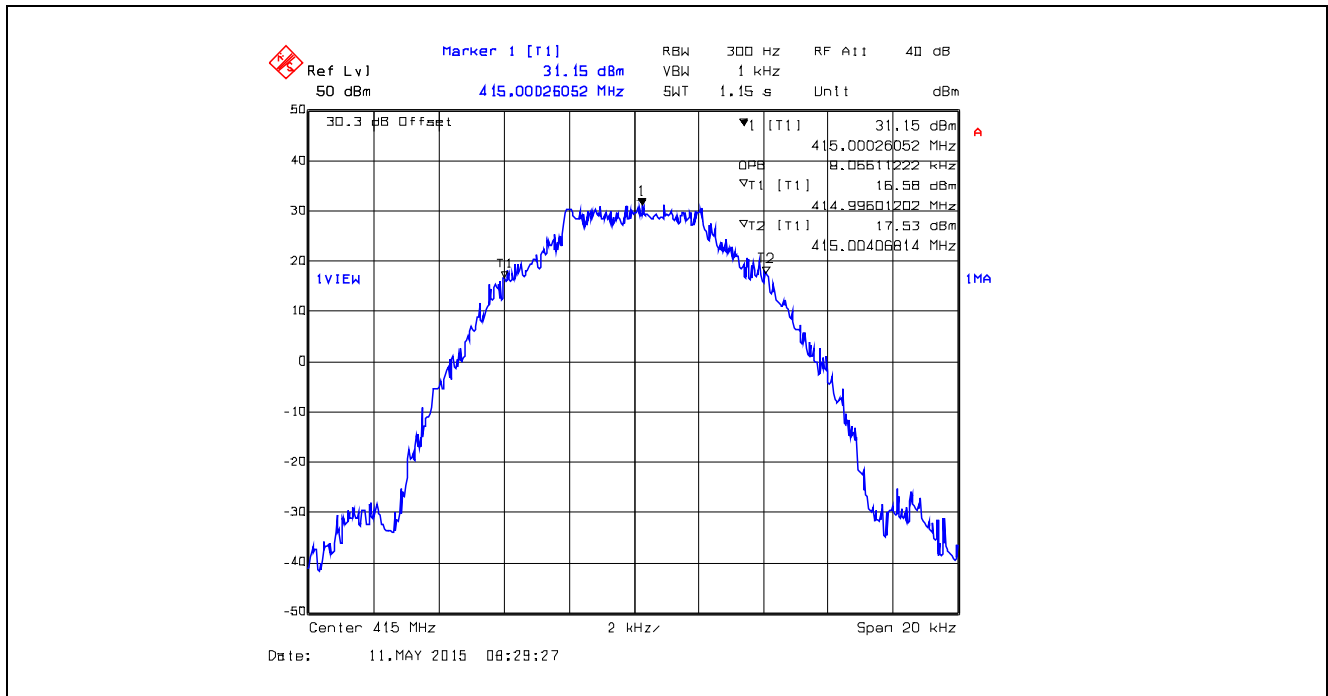

Plot 5.4.4.1.33. 99% Occupied Bandwidth, 12.5 kHz Channel Spacing, Digital 9.6 kbps, 429.9 MHz

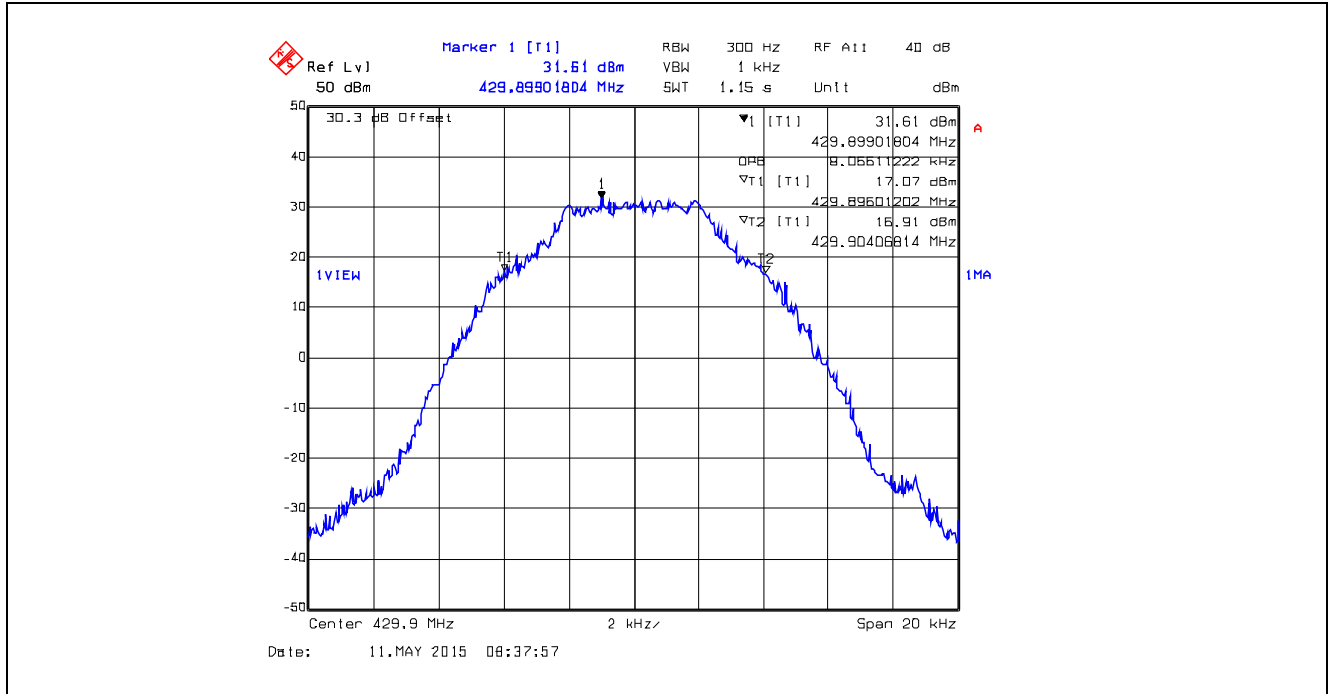

Plot 5.4.4.1.34. 99% Occupied Bandwidth, 12.5 kHz Channel Spacing, Digital 9.6 kbps, 450.1 MHz

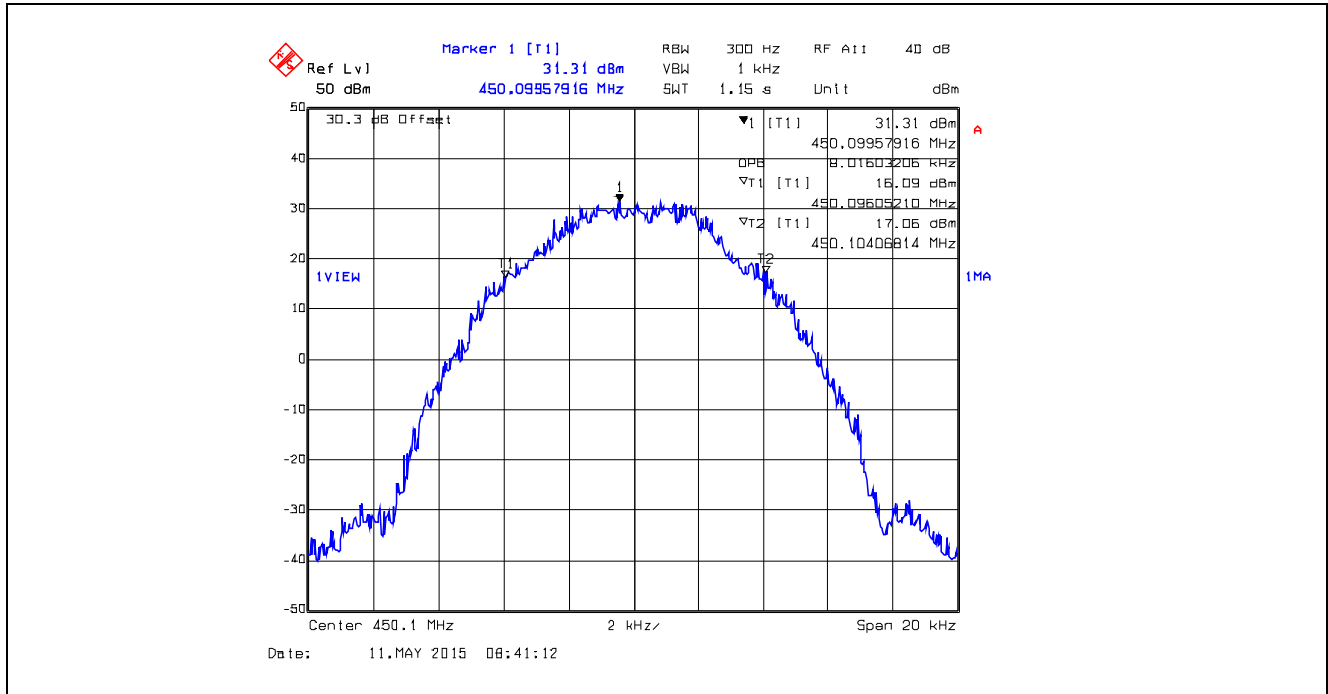

Plot 5.4.4.1.35. 99% Occupied Bandwidth, 12.5 kHz Channel Spacing, Digital 9.6 kbps, 470.0 MHz

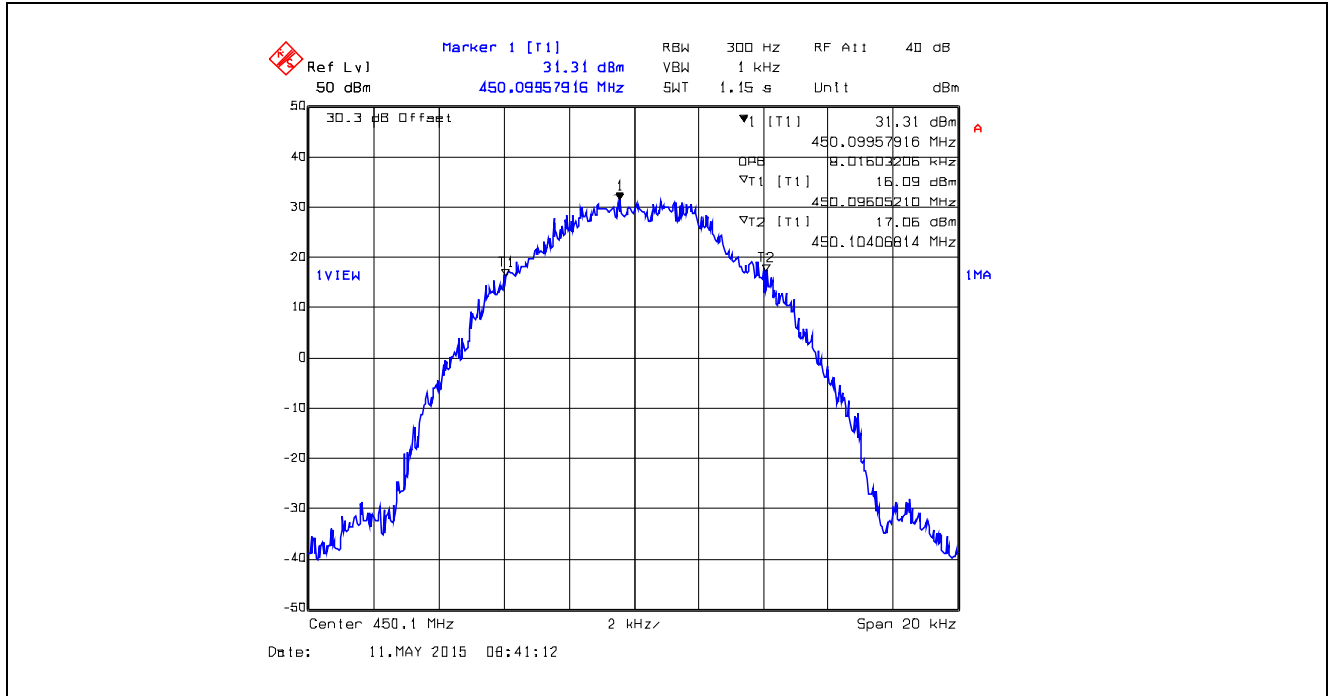

Plot 5.4.4.1.36. 99% Occupied Bandwidth, 12.5 kHz Channel Spacing, Digital 9.6 kbps, 511.9 MHz

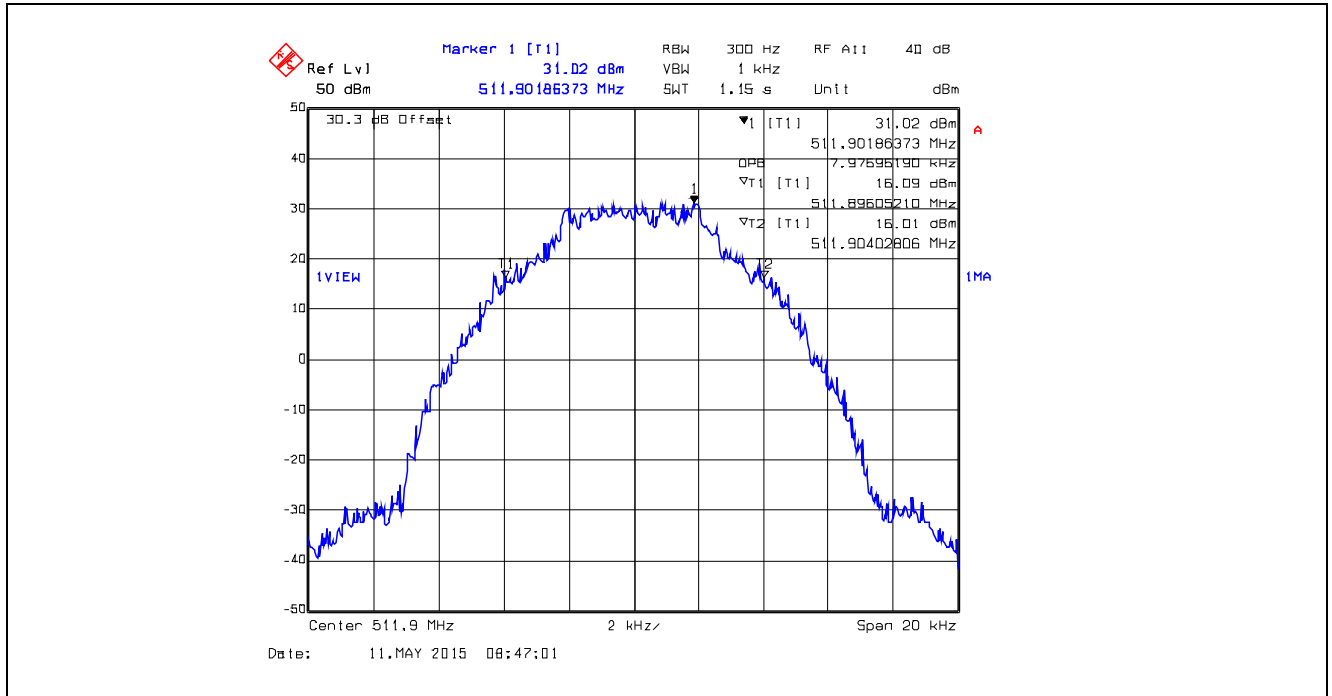

Plot 5.4.4.1.37. 99% Occupied Bandwidth, 6.25 kHz Channel Spacing, Digital 4.8 kbps, 381.1 MHz

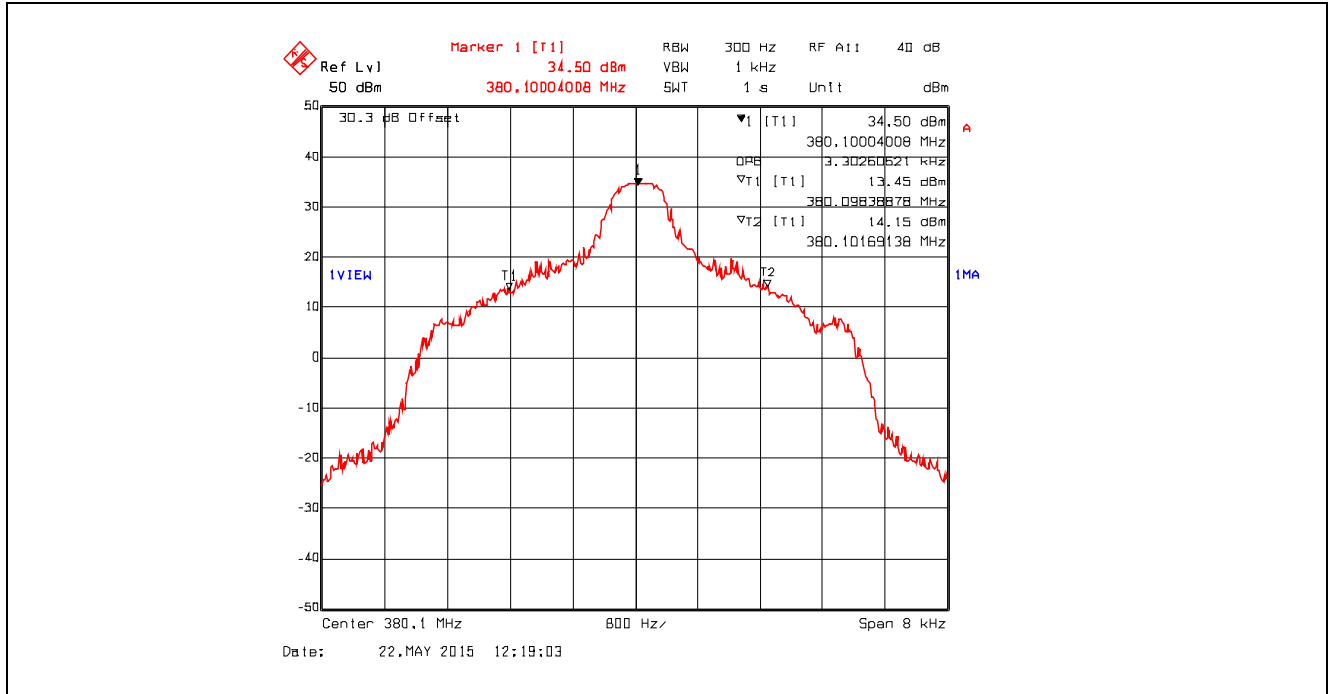

Plot 5.4.4.1.38. 99% Occupied Bandwidth, 6.25 kHz Channel Spacing, Digital 4.8 kbps, 390.0 MHz

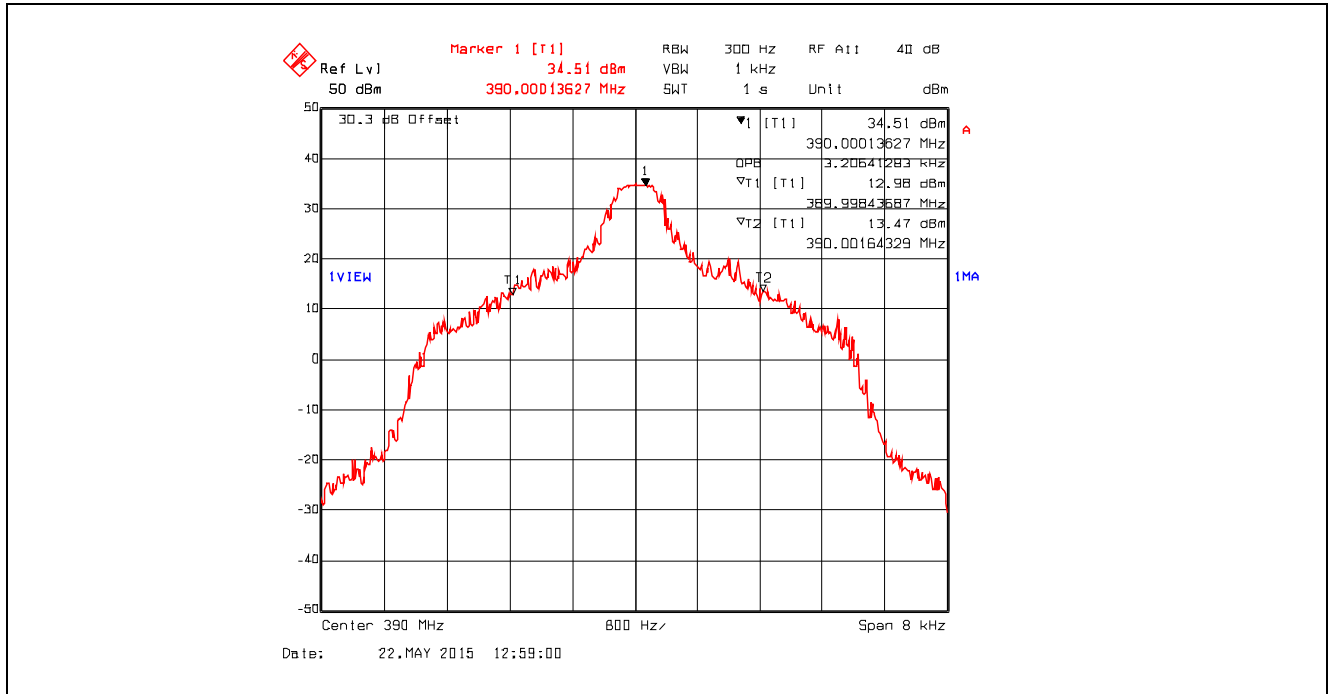

ULTRATECH GROUP OF LABS

3000 Bristol Circle, Oakville, Ontario, Canada L6H 6G4
 Tel. #: 905-829-1570, Fax. #: 905-829-8050, Email: vic@ultratech-labs.com, Website: <http://www.ultratech-labs.com>

File #: 15FSG141_FCC90
 July 8, 2015

All test results contained in this engineering test report are traceable to National Institute of Standards and Technology (NIST)

Plot 5.4.4.1.39. 99% Occupied Bandwidth, 6.25 kHz Channel Spacing, Digital 4.8 kbps, 399.9 MHz

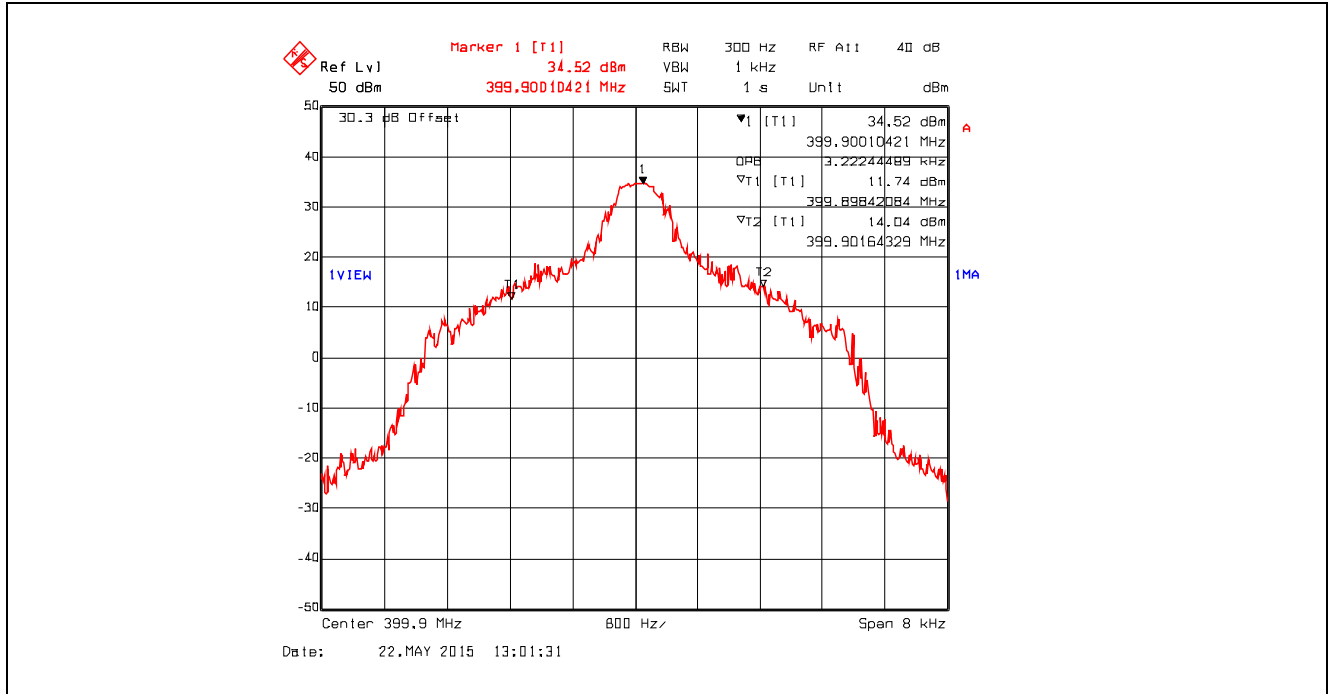

Plot 5.4.4.1.40. 99% Occupied Bandwidth, 6.25 kHz Channel Spacing, Digital 4.8 kbps, 406.2 MHz

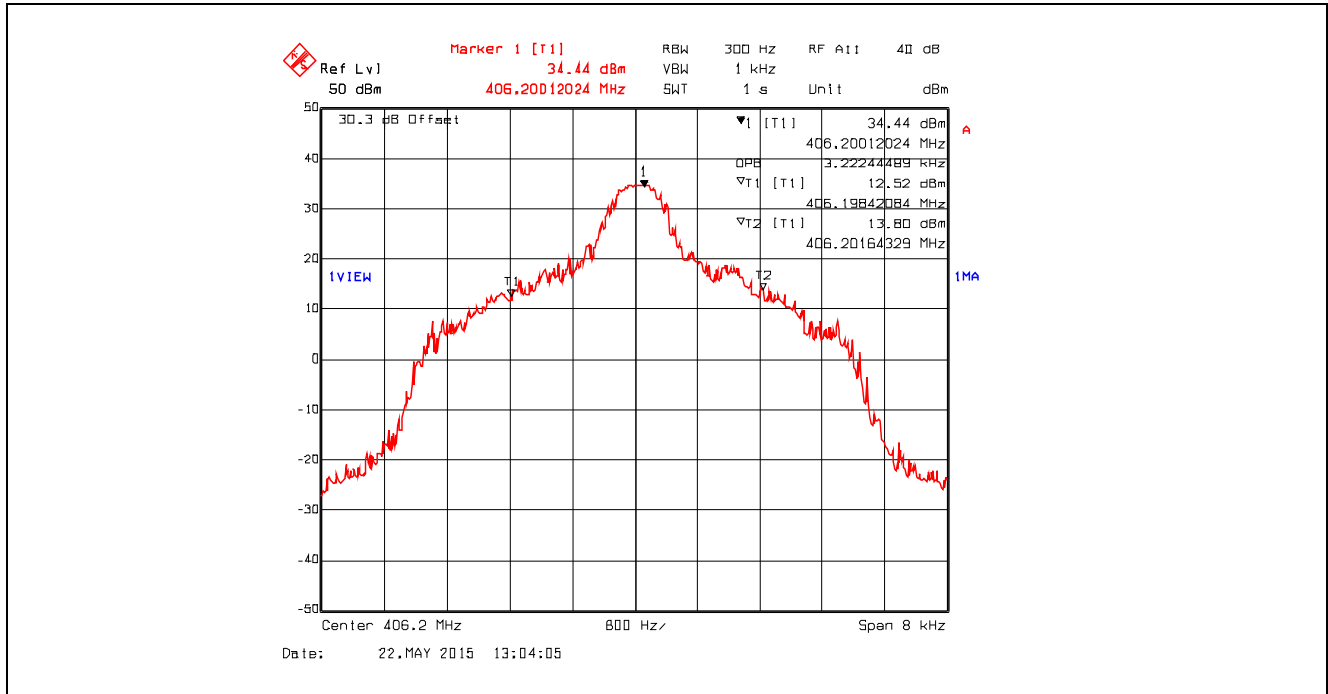

Plot 5.4.4.1.41. 99% Occupied Bandwidth, 6.25 kHz Channel Spacing, Digital 4.8 kbps, 415.0 MHz

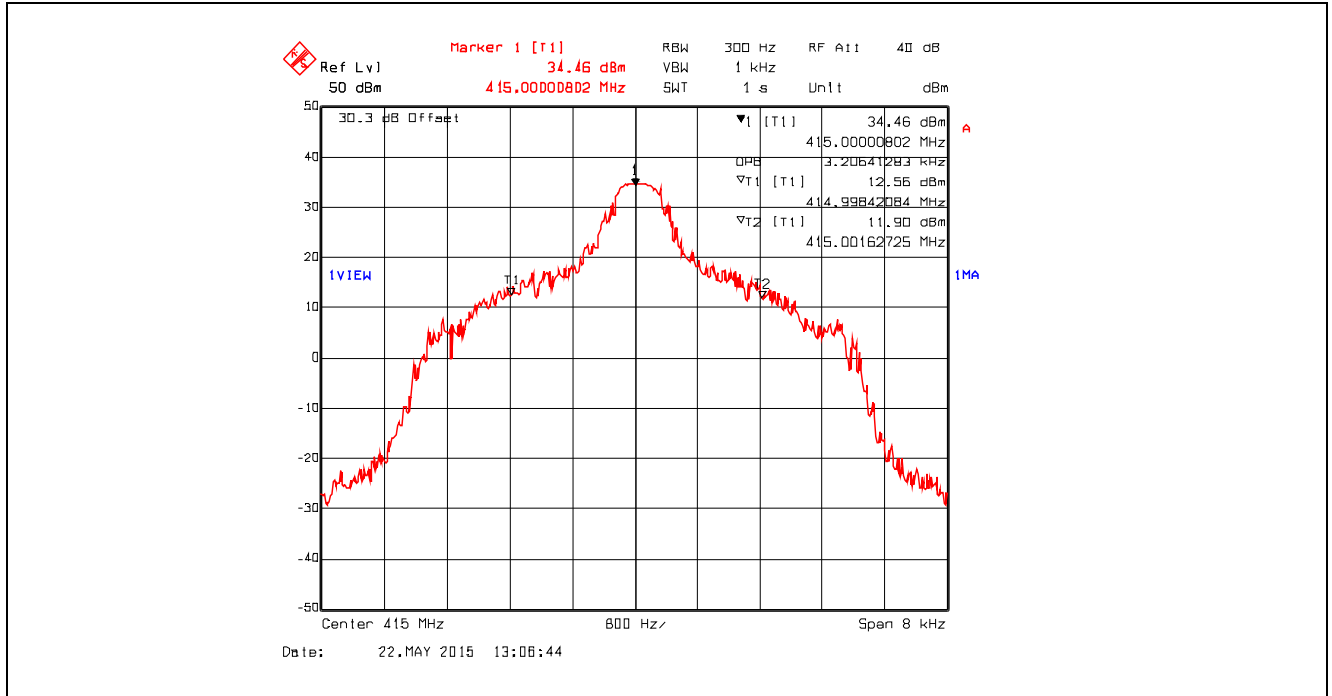

Plot 5.4.4.1.42. 99% Occupied Bandwidth, 6.25 kHz Channel Spacing, Digital 4.8 kbps, 429.9 MHz

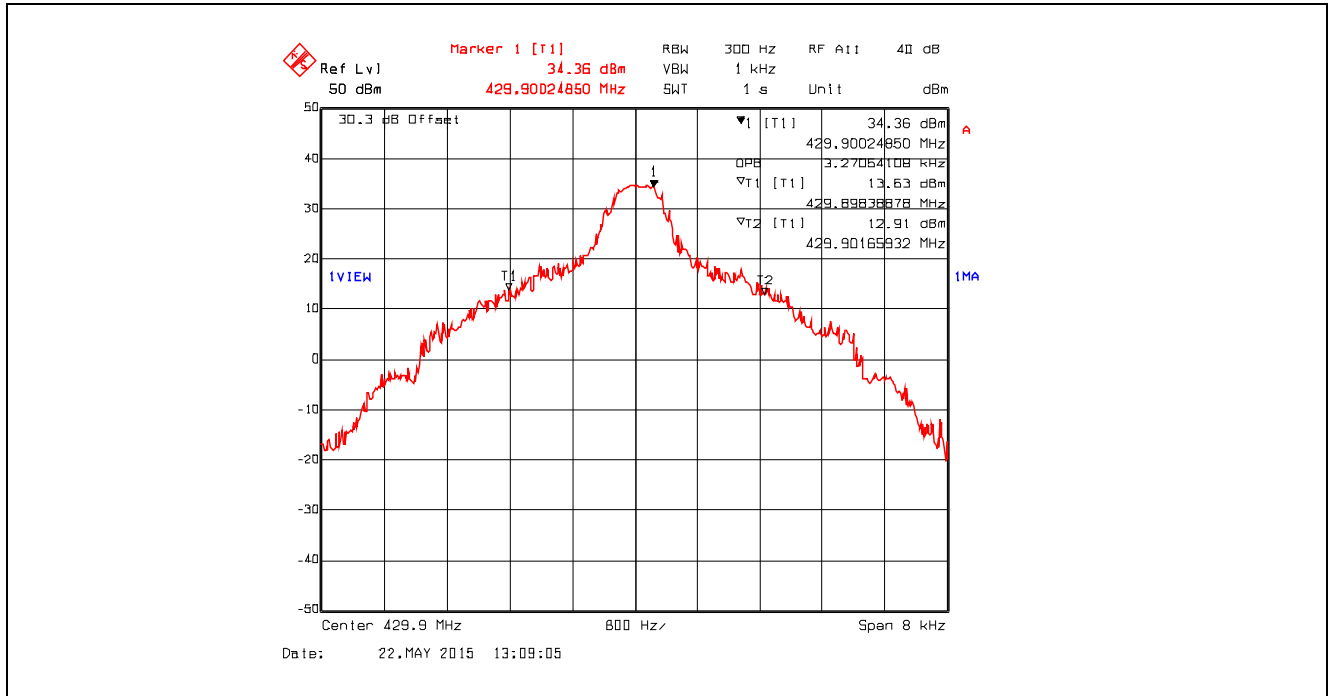

ULTRATECH GROUP OF LABS

3000 Bristol Circle, Oakville, Ontario, Canada L6H 6G4
 Tel. #: 905-829-1570, Fax. #: 905-829-8050, Email: vic@ultratech-labs.com, Website: <http://www.ultratech-labs.com>

File #: 15FSG141_FCC90
 July 8, 2015

All test results contained in this engineering test report are traceable to National Institute of Standards and Technology (NIST)

Plot 5.4.4.1.43. 99% Occupied Bandwidth, 6.25 kHz Channel Spacing, Digital 4.8 kbps, 450.1 MHz

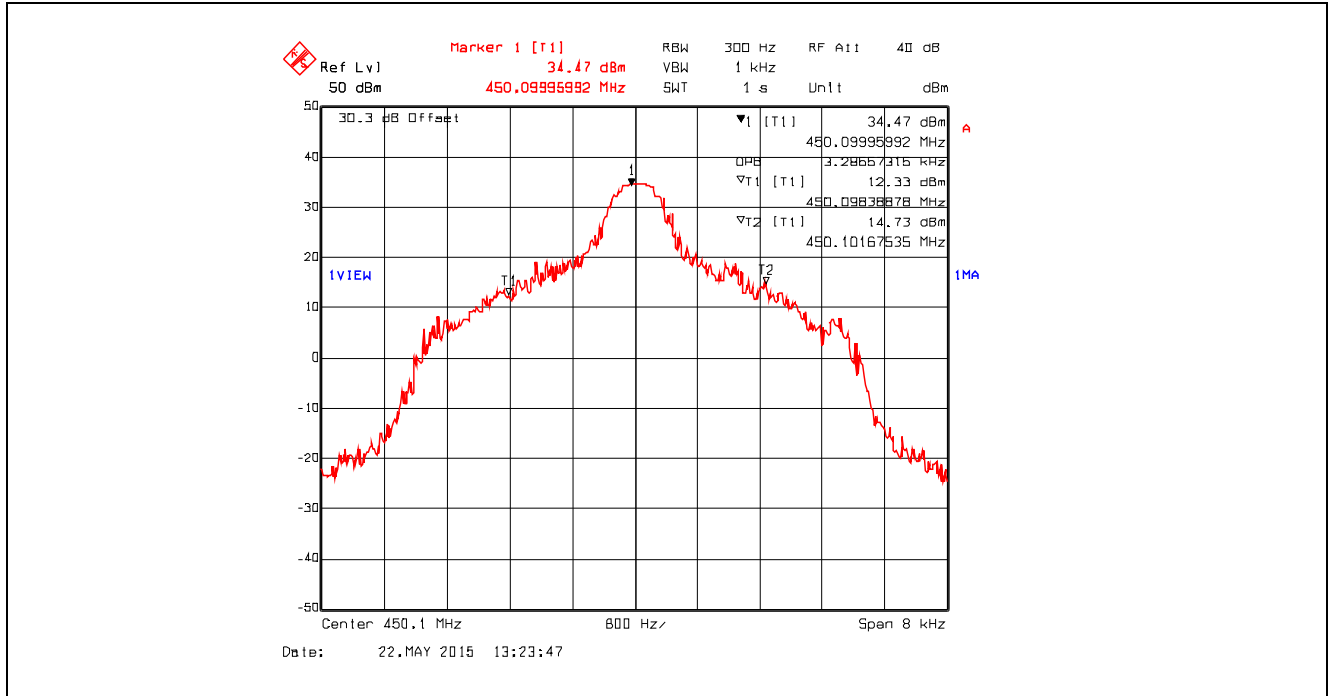

Plot 5.4.4.1.44. 99% Occupied Bandwidth, 6.25 kHz Channel Spacing, Digital 4.8 kbps, 470.0 MHz

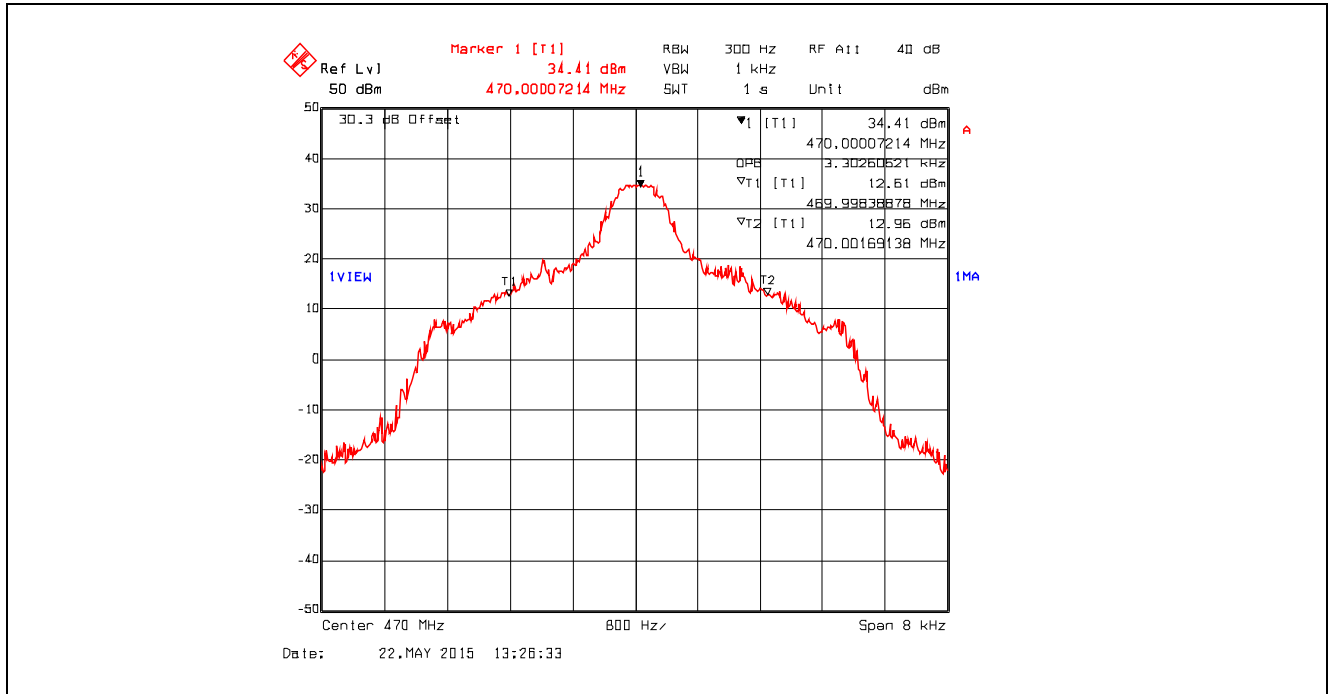

ULTRATECH GROUP OF LABS

3000 Bristol Circle, Oakville, Ontario, Canada L6H 6G4
 Tel. #: 905-829-1570, Fax. #: 905-829-8050, Email: vic@ultratech-labs.com, Website: <http://www.ultratech-labs.com>

File #: 15FSG141_FCC90
 July 8, 2015

All test results contained in this engineering test report are traceable to National Institute of Standards and Technology (NIST)

Plot 5.4.4.1.45. 99% Occupied Bandwidth, 6.25 kHz Channel Spacing, Digital 4.8 kbps, 511.9 MHz

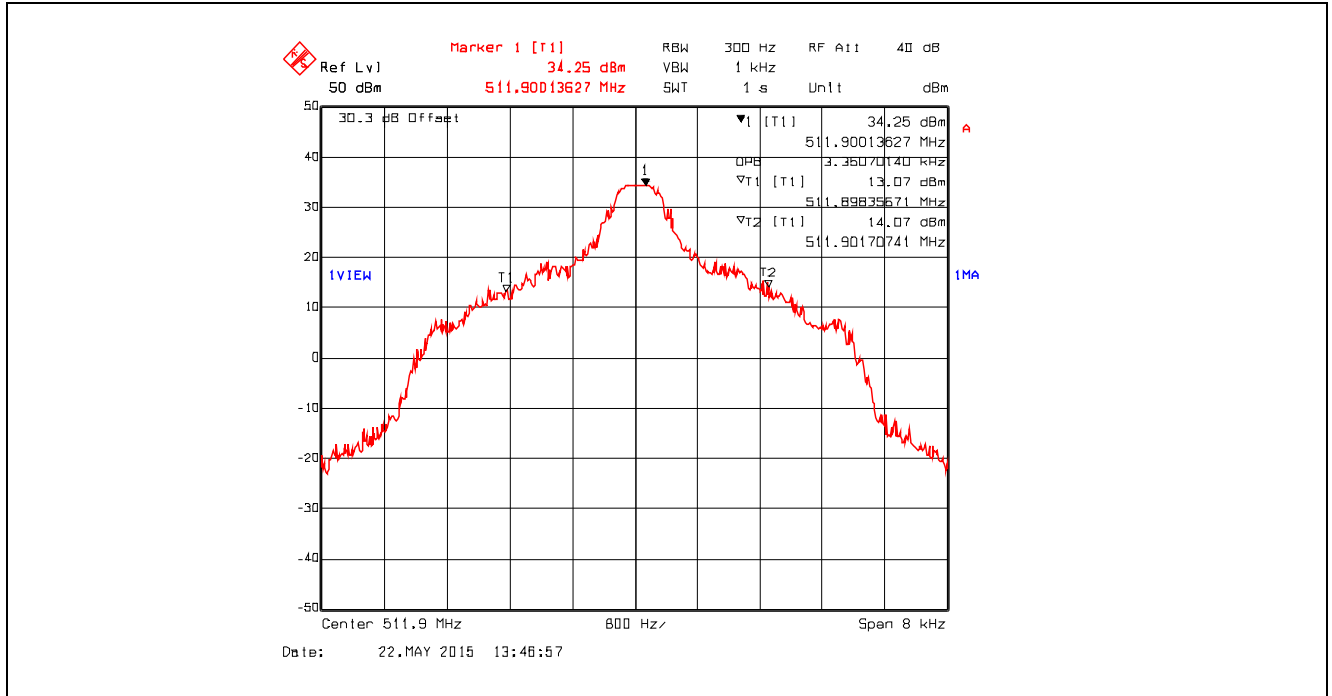

5.4.4.2. Emission Mask B

Plot 5.4.4.2.1. Emission Mask B, Analog, 381.1 MHz, High Power

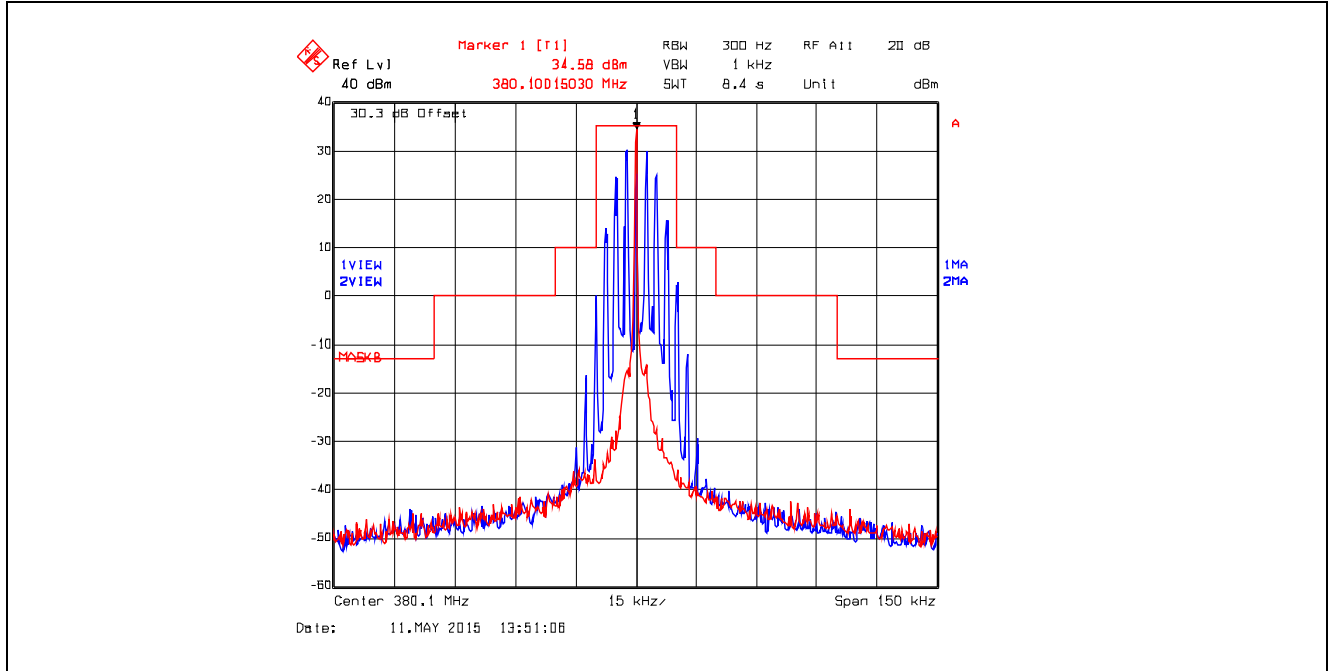

Plot 5.4.4.2.2. Emission Mask B, Analog, 381.1 MHz, Low Power

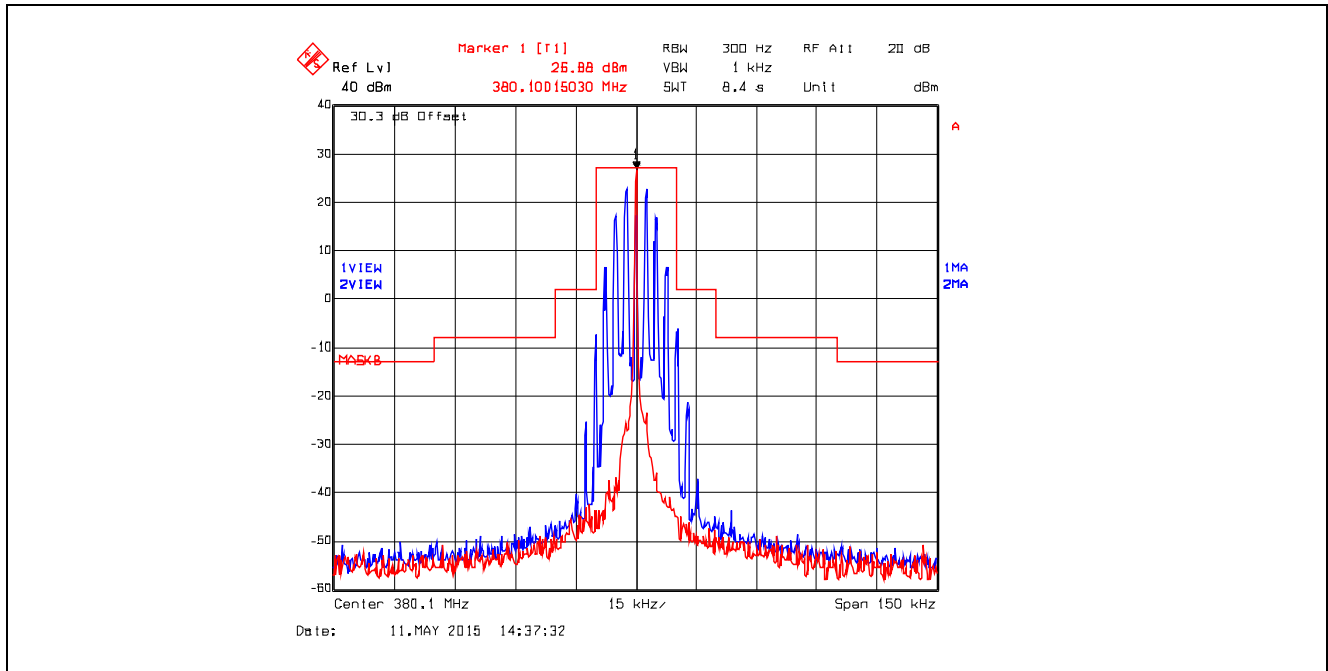

Plot 5.4.4.2.3. Emission Mask B, Analog, 390.0 MHz, High Power

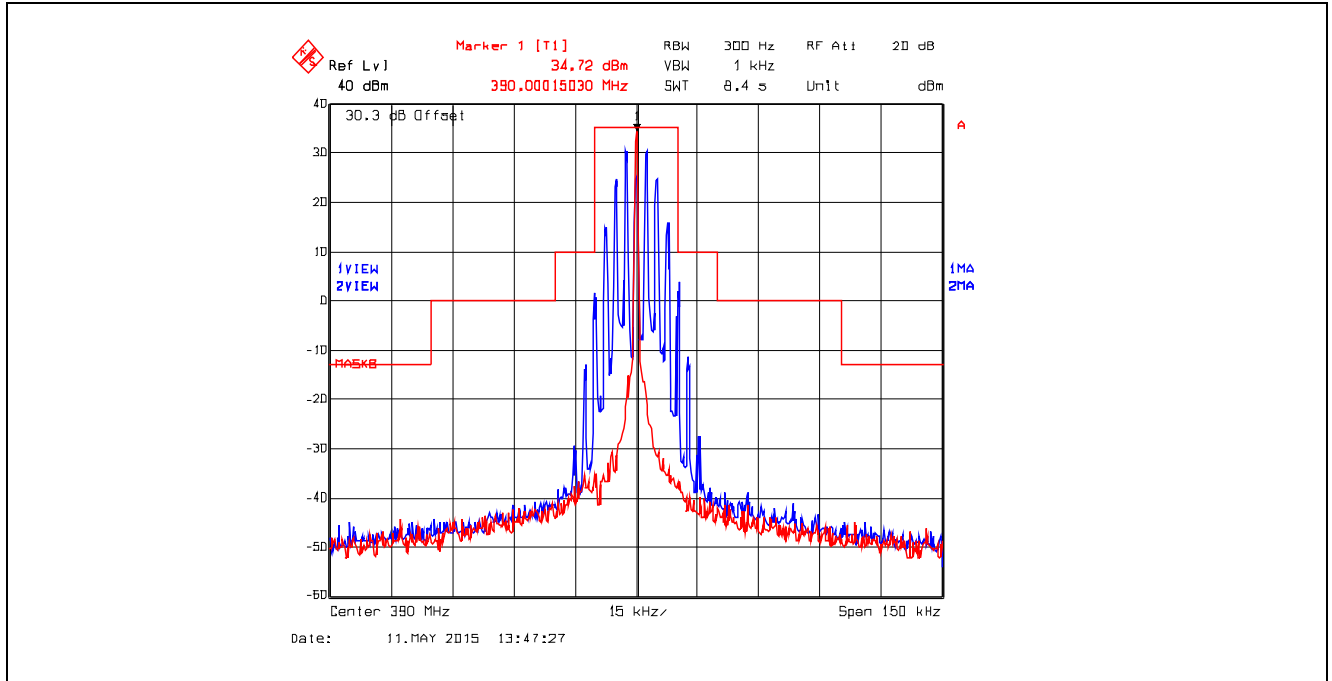

Plot 5.4.4.2.4. Emission Mask B, Analog, 390.0 MHz, Low Power

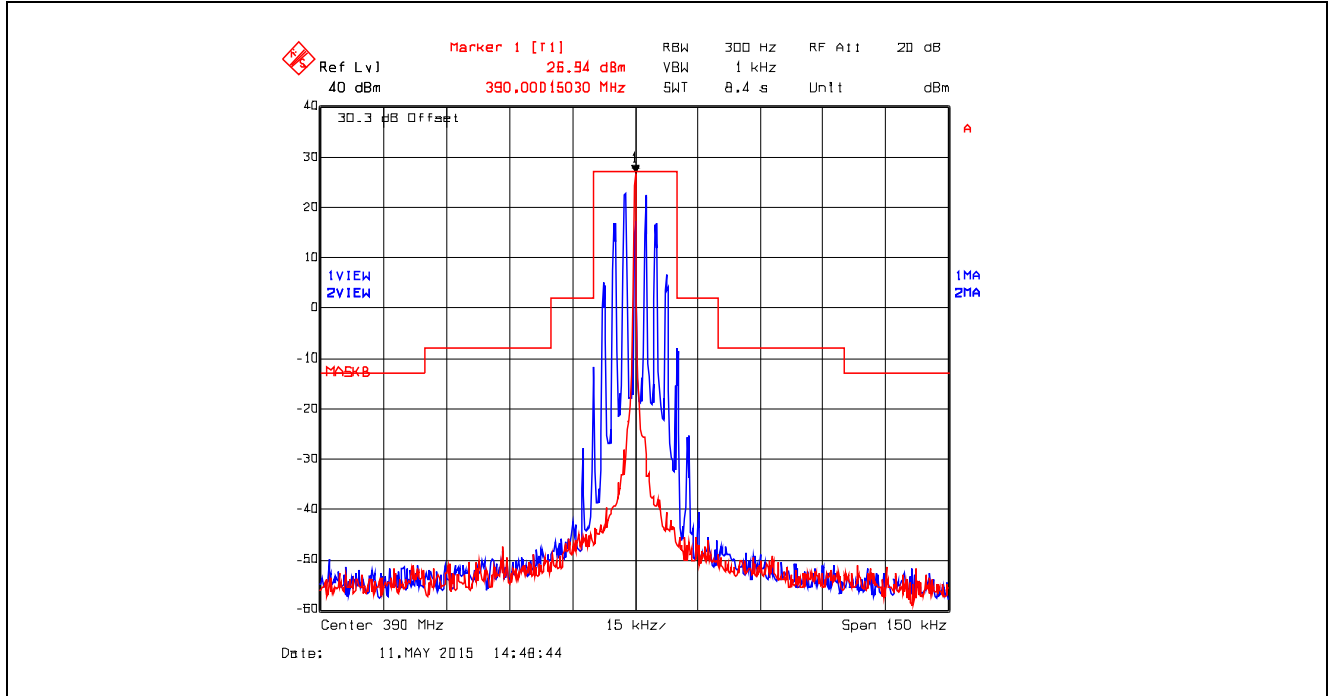

Plot 5.4.4.2.5. Emission Mask B, Analog, 399.9 MHz, High Power

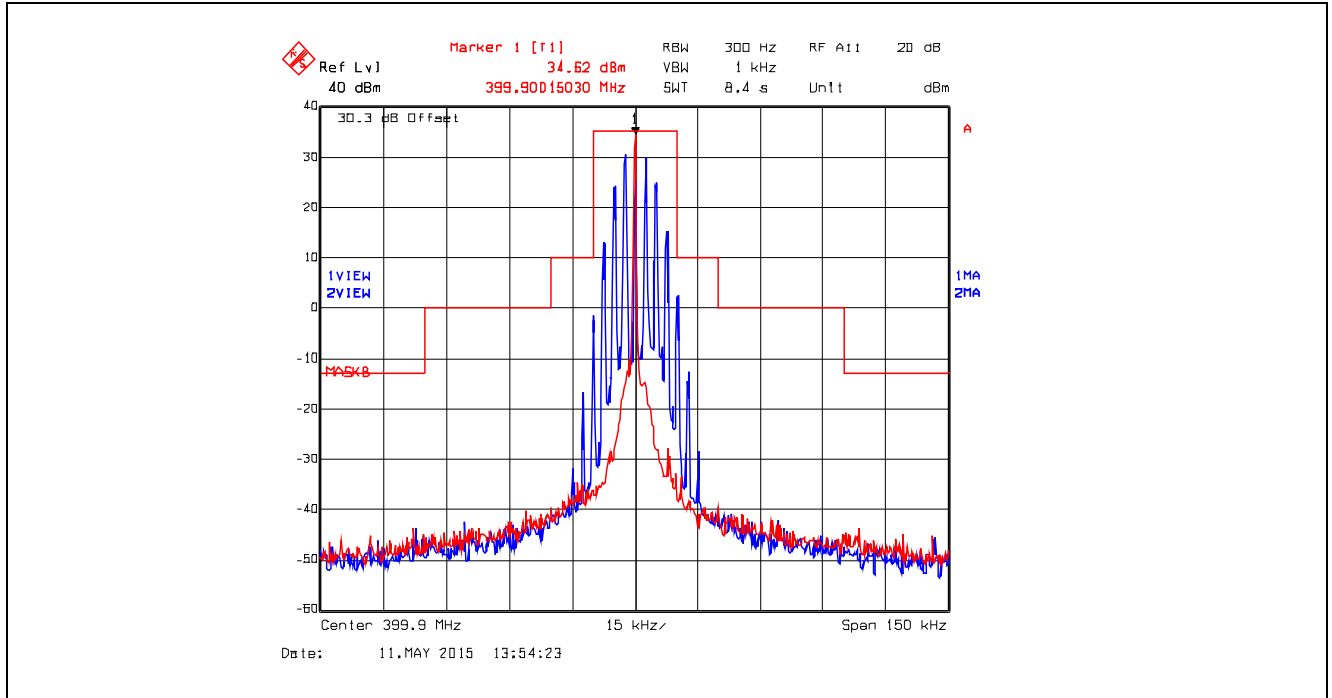

Plot 5.4.4.2.6. Emission Mask B, Analog, 399.9 MHz, Low Power

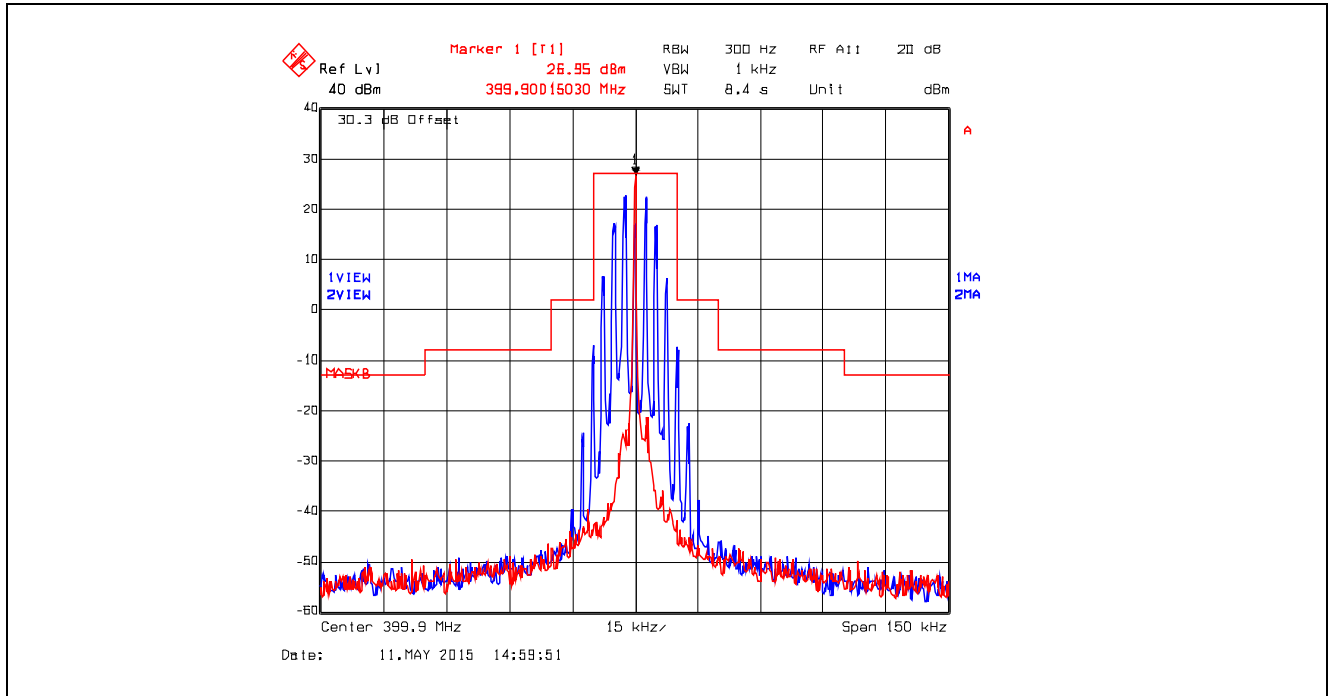

Plot 5.4.4.2.7. Emission Mask B, Analog, 406.2 MHz, High Power

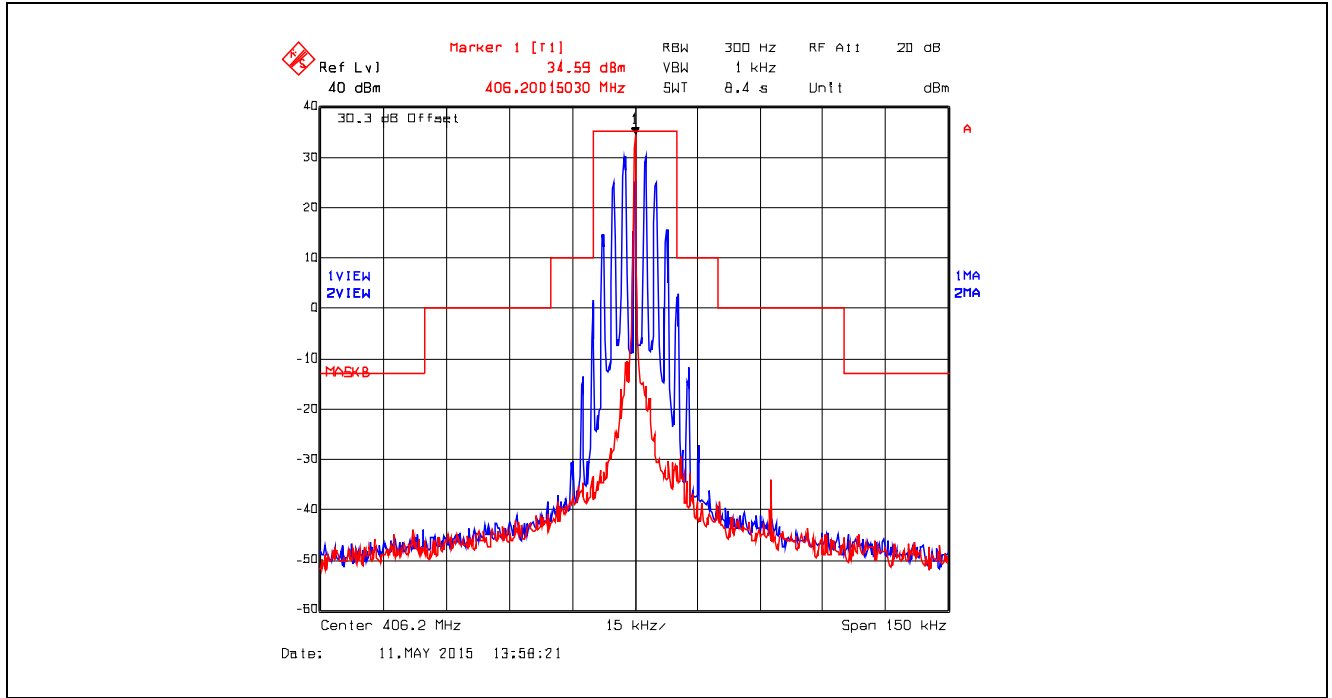

Plot 5.4.4.2.8. Emission Mask B, Analog, 406.2 MHz, Low Power

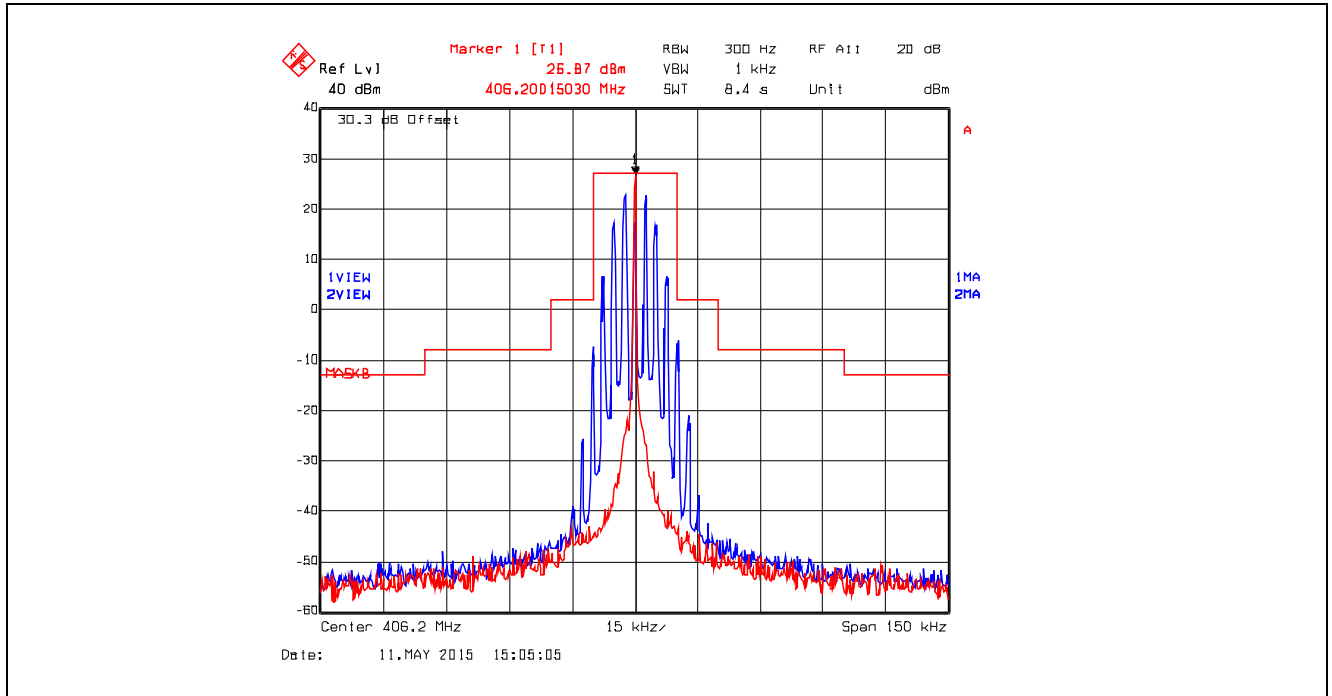

ULTRATECH GROUP OF LABS

3000 Bristol Circle, Oakville, Ontario, Canada L6H 6G4
Tel. #: 905-829-1570, Fax. #: 905-829-8050, Email: vic@ultratech-labs.com, Website: <http://www.ultratech-labs.com>

File #: 15FSG141_FCC90
July 8, 2015

All test results contained in this engineering test report are traceable to National Institute of Standards and Technology (NIST)

Plot 5.4.4.2.9. Emission Mask B, Analog, 415.0 MHz, High Power

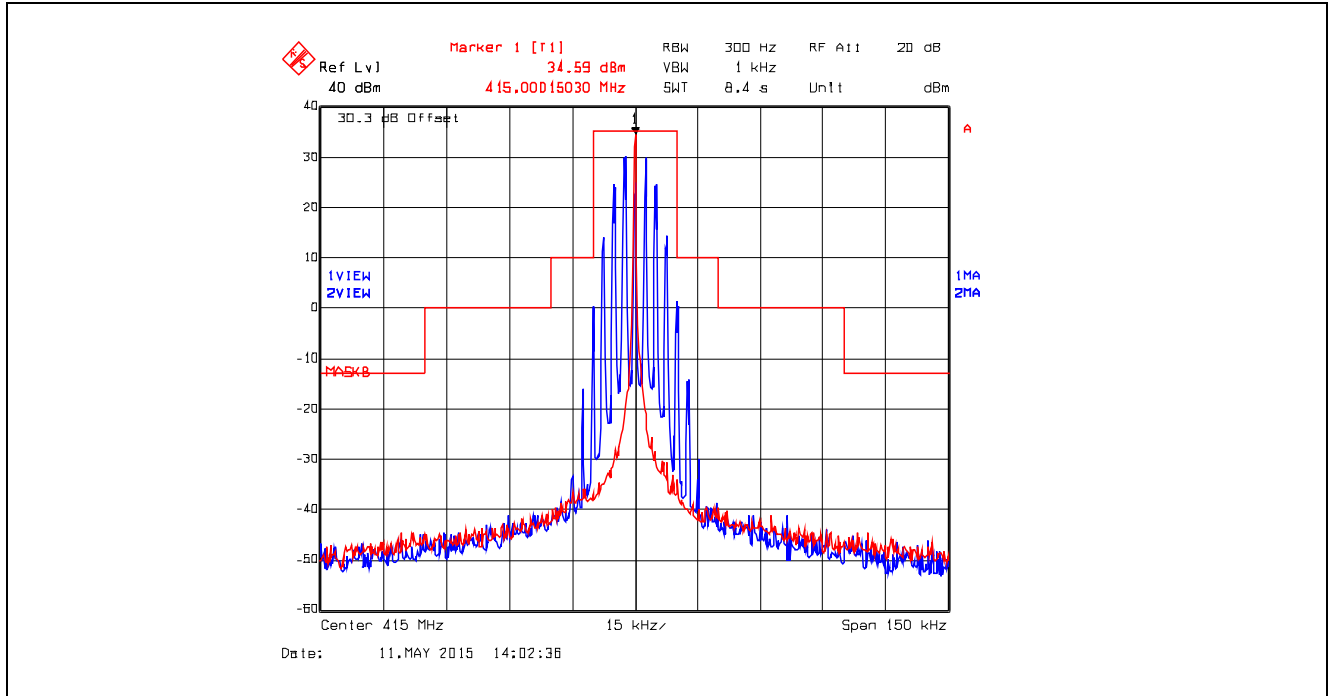

Plot 5.4.4.2.10. Emission Mask B, Analog, 415.0 MHz, Low Power

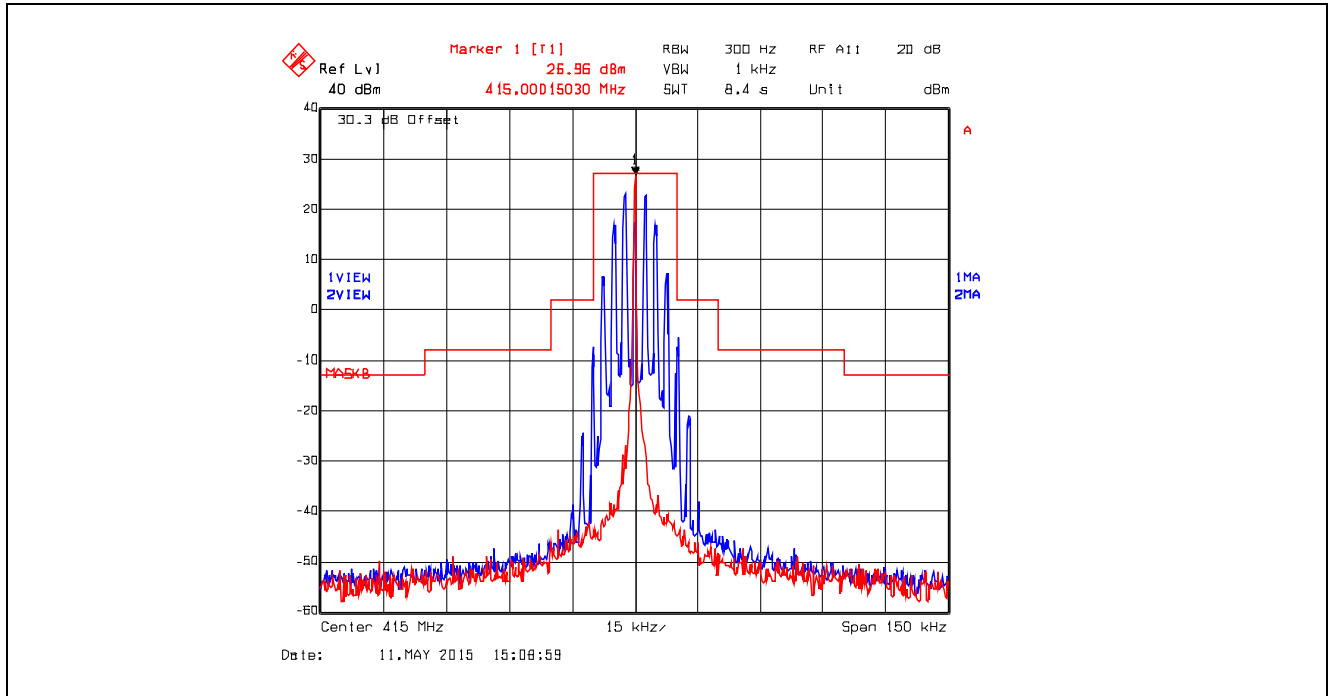

ULTRATECH GROUP OF LABS

3000 Bristol Circle, Oakville, Ontario, Canada L6H 6G4
Tel. #: 905-829-1570, Fax. #: 905-829-8050, Email: vic@ultratech-labs.com, Website: <http://www.ultratech-labs.com>

File #: 15FSG141_FCC90
July 8, 2015

All test results contained in this engineering test report are traceable to National Institute of Standards and Technology (NIST)

Plot 5.4.4.2.11. Emission Mask B, Analog, 429.9 MHz, High Power

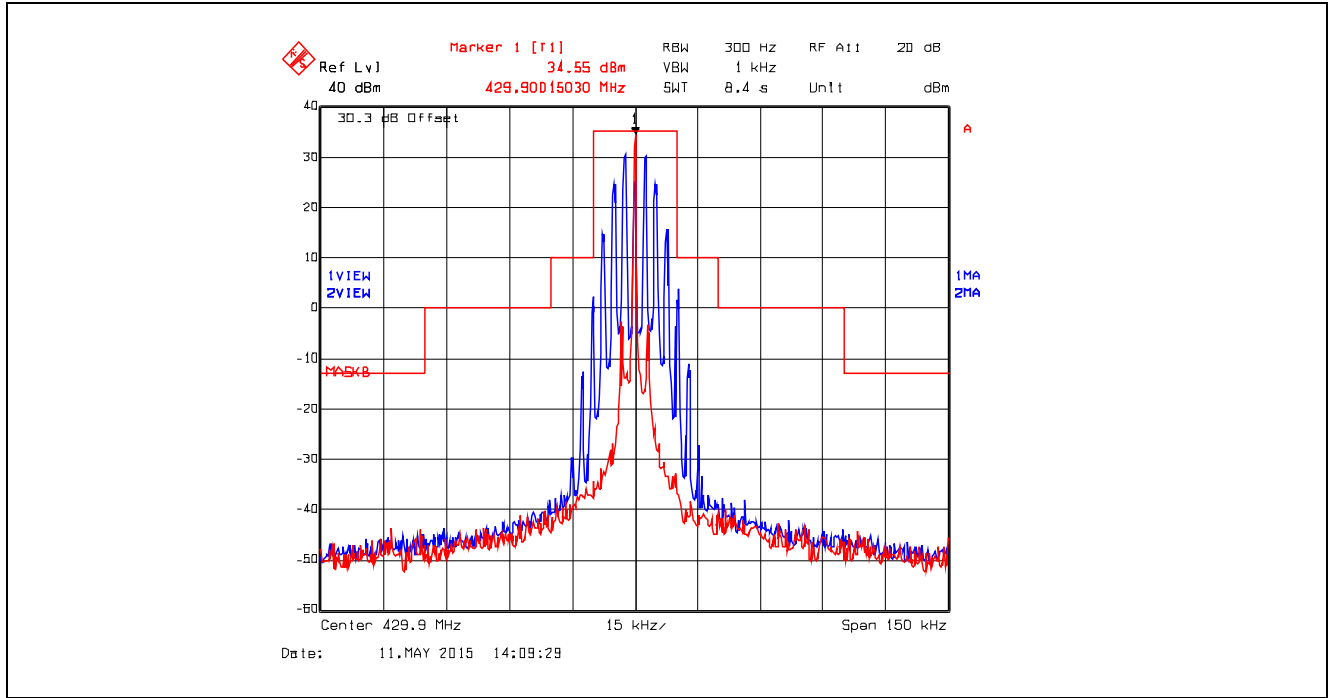

Plot 5.4.4.2.12. Emission Mask B, Analog, 429.9 MHz, Low Power

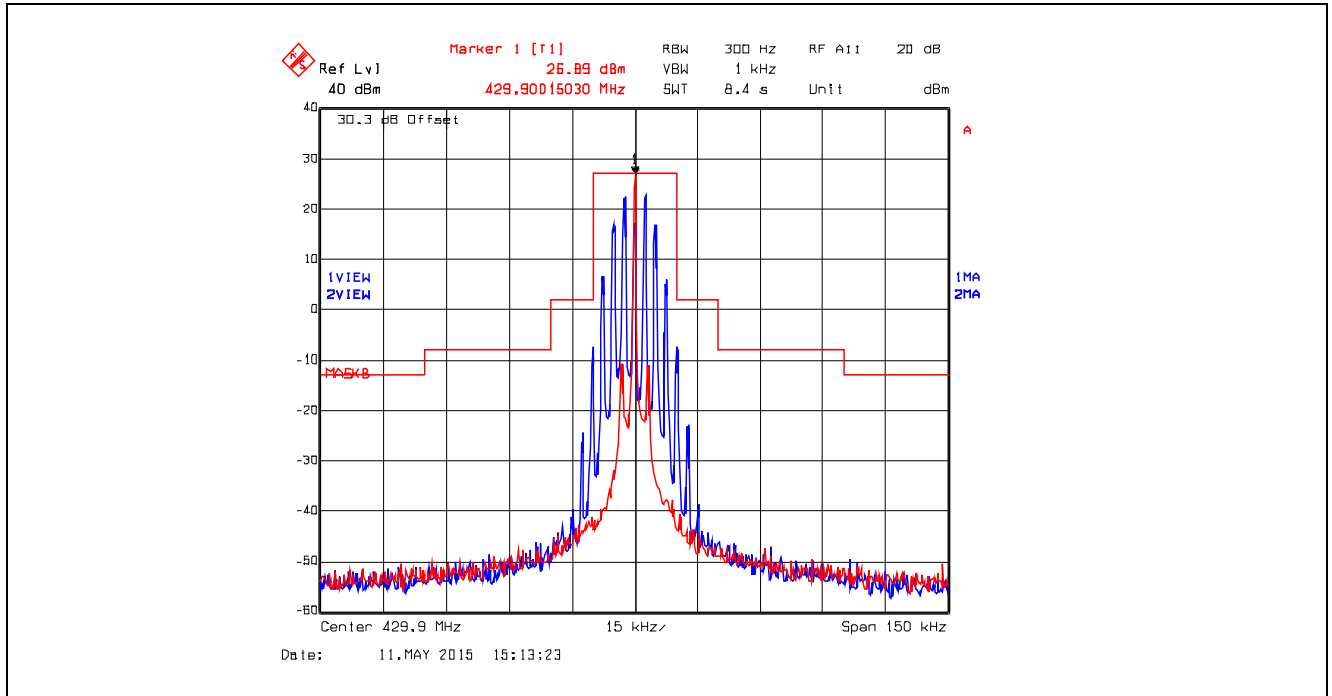

Plot 5.4.4.2.13. Emission Mask B, Analog, 450.1 MHz, High Power

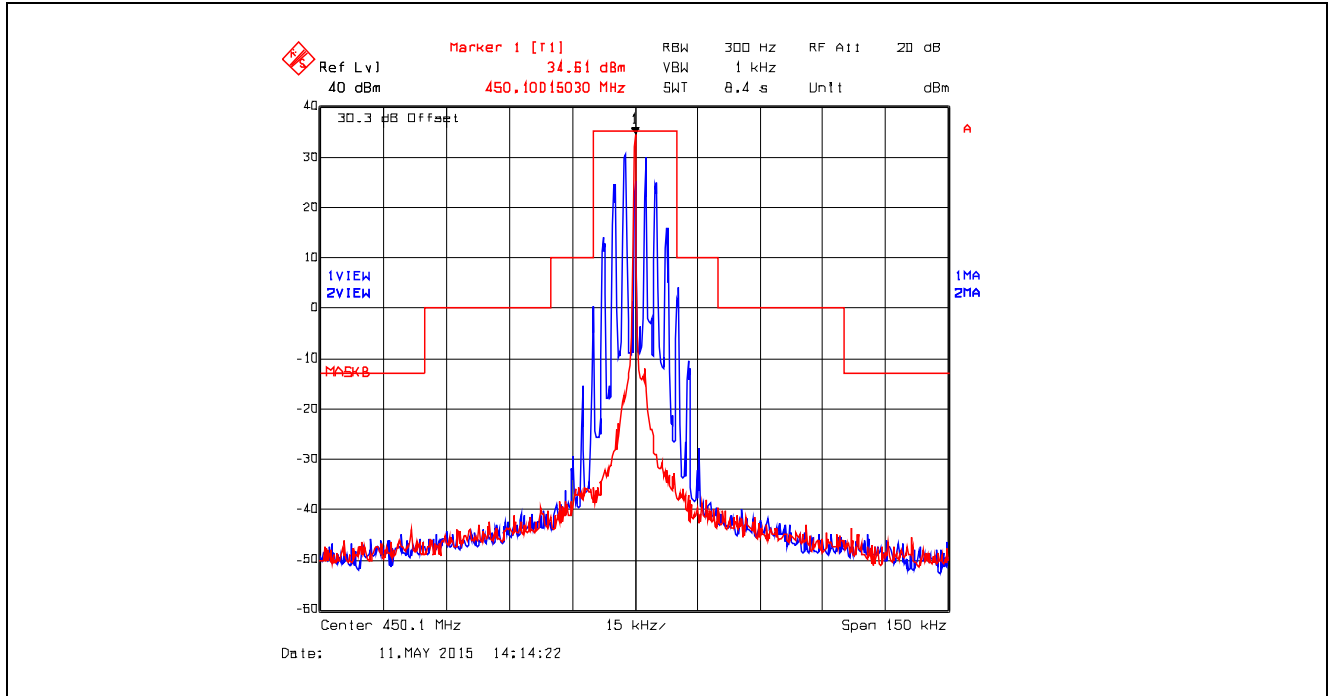

Plot 5.4.4.2.14. Emission Mask B, Analog, 450.1 MHz, Low Power

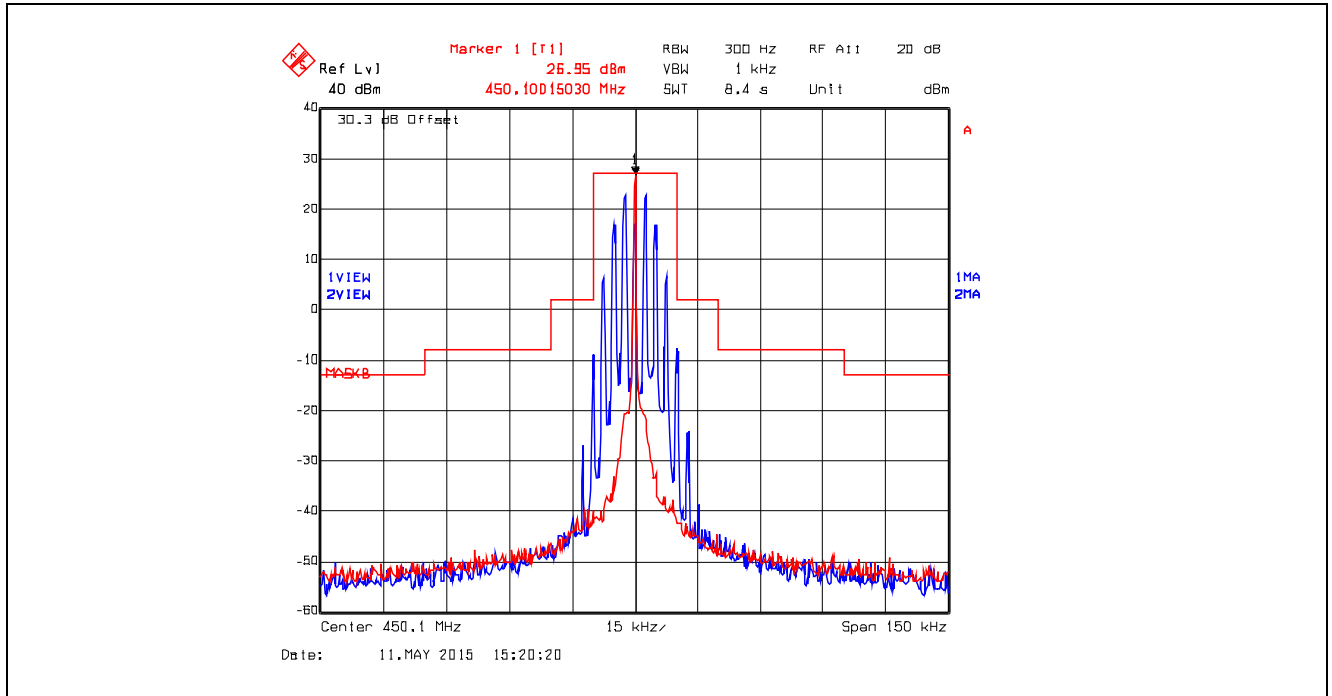

Plot 5.4.4.2.15. Emission Mask B, Analog, 470.0 MHz, High Power

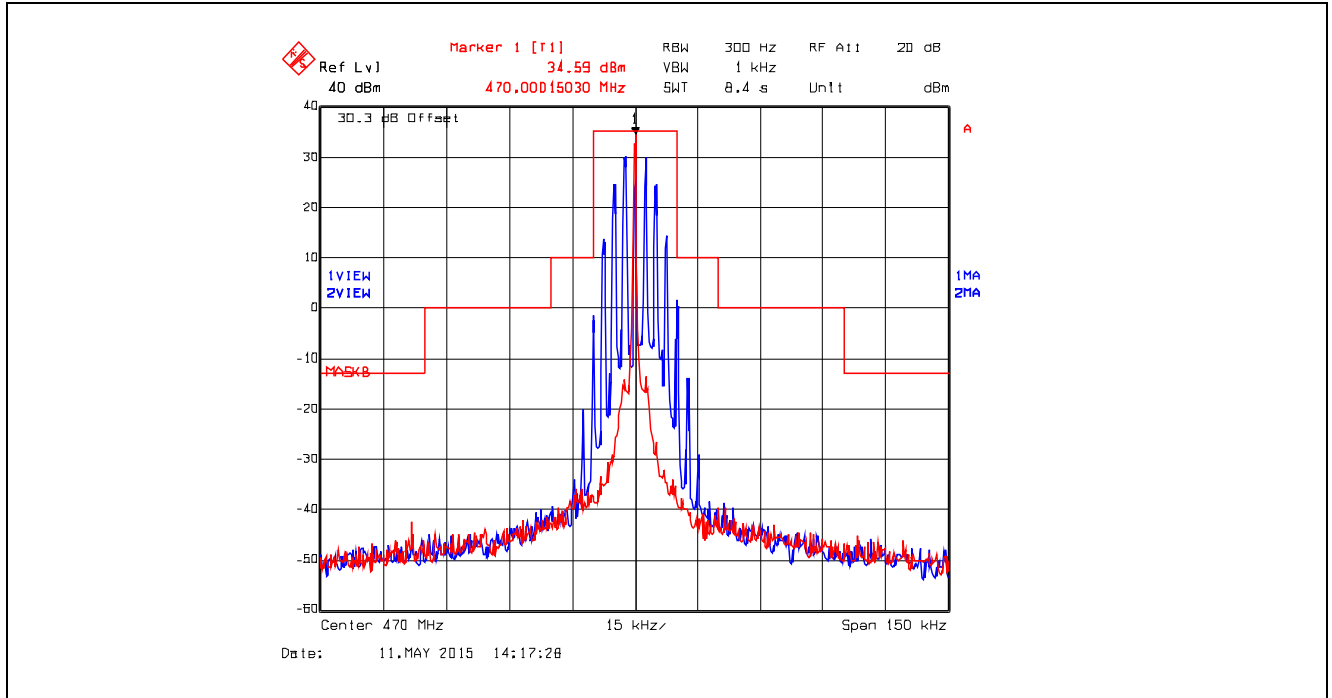

Plot 5.4.4.2.16. Emission Mask B, Analog, 470.0 MHz, Low Power

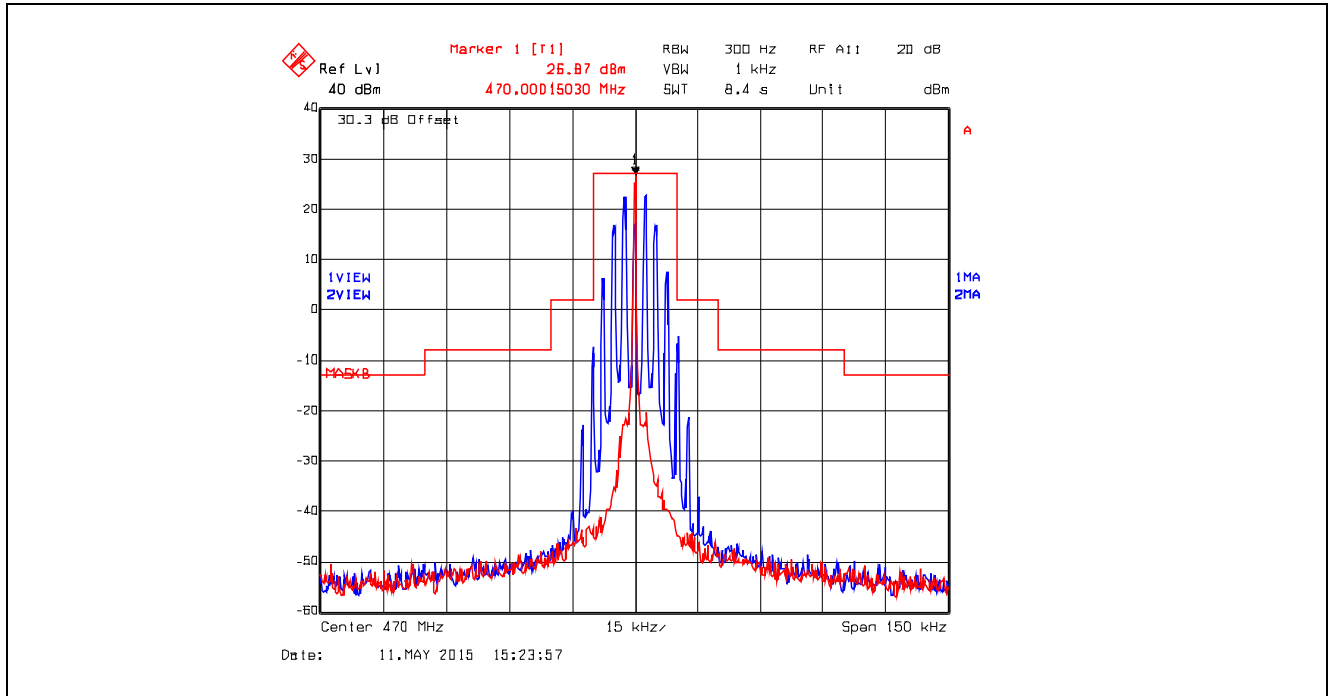

Plot 5.4.4.2.17. Emission Mask B, Analog, 511.9 MHz, High Power

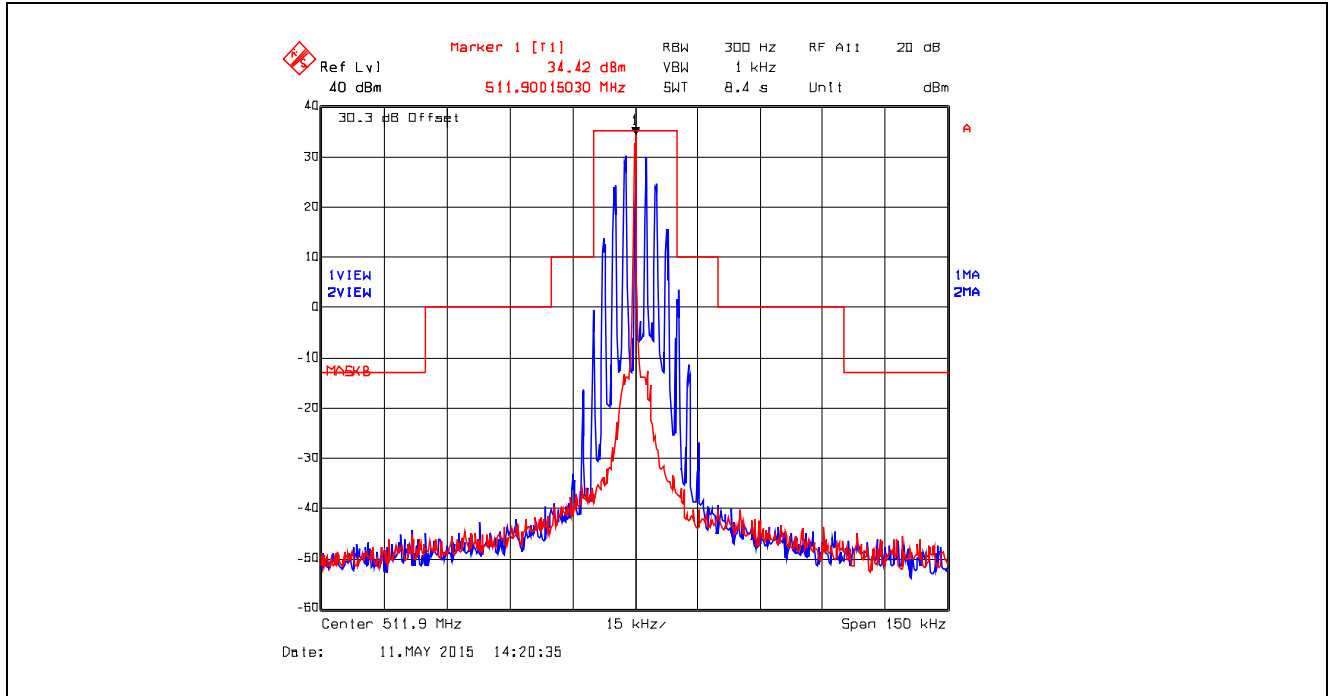

Plot 5.4.4.2.18. Emission Mask B, Analog, 511.9 MHz, Low Power

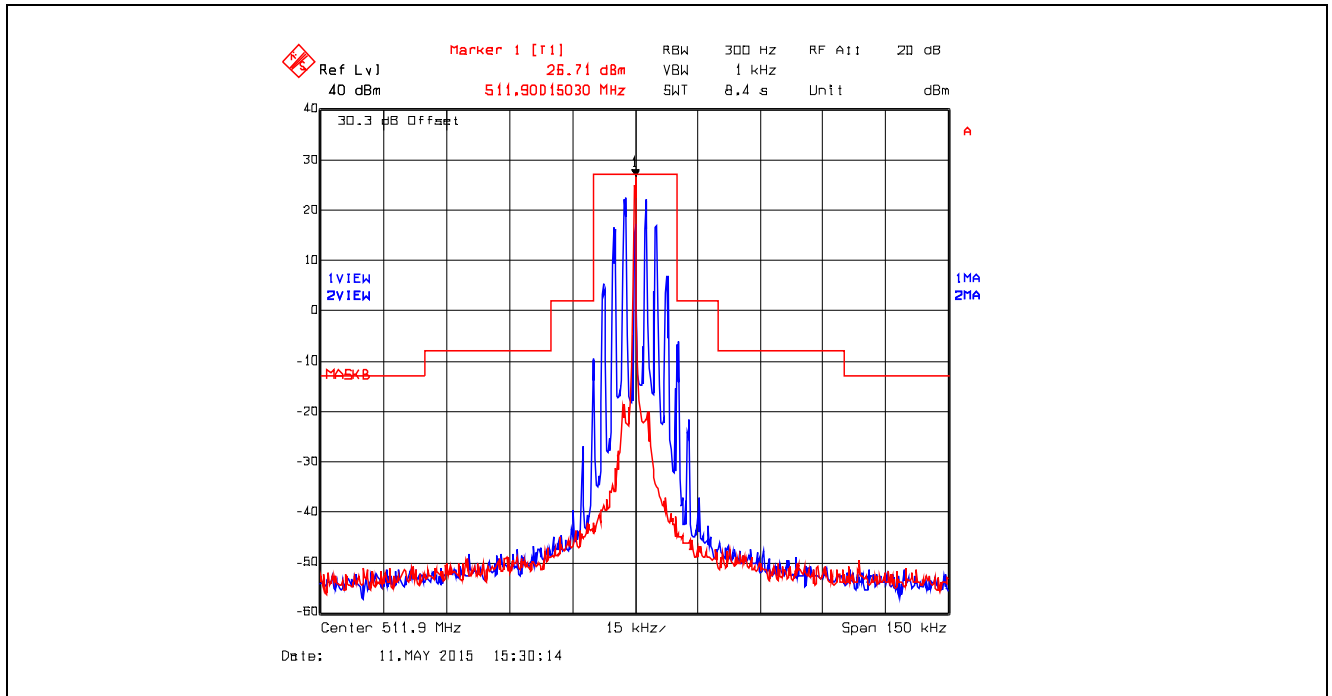

5.4.4.3. Emission Mask C

Plot 5.4.4.3.1. Emission Mask C, Digital at 19.2 kbps, 381.1 MHz, High Power

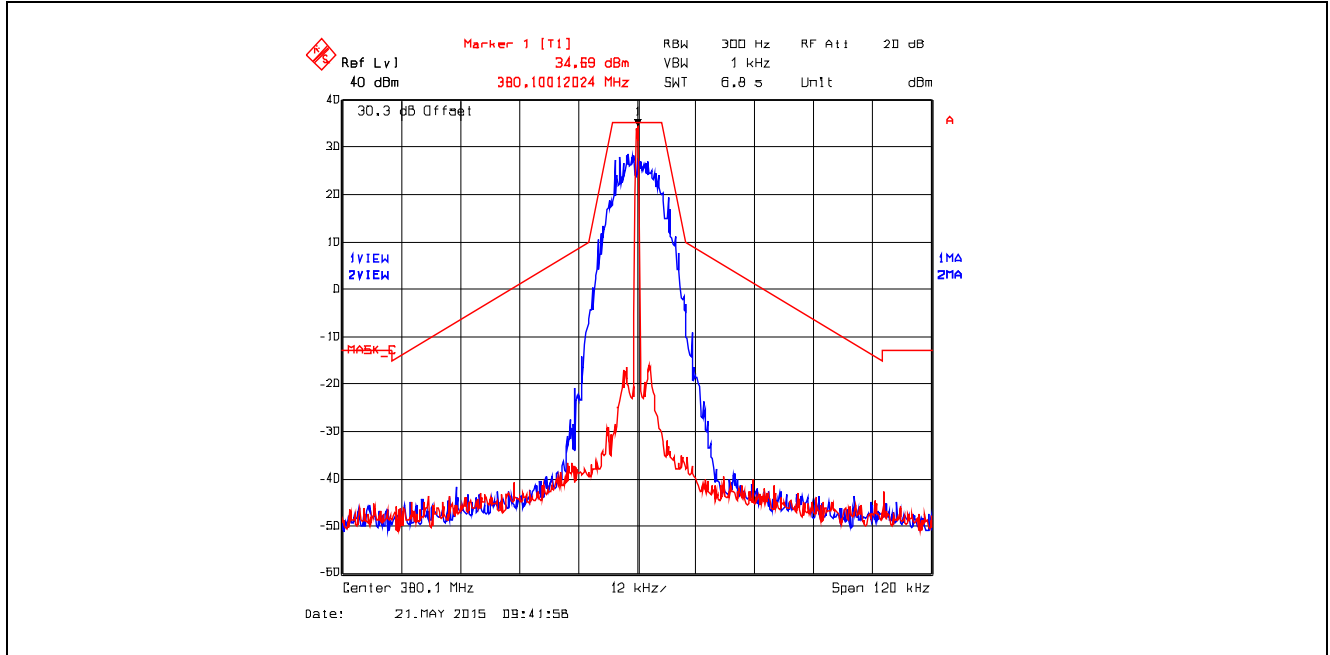

Plot 5.4.4.3.2. Emission Mask C, Digital at 19.2 kbps, 381.1 MHz, Low Power

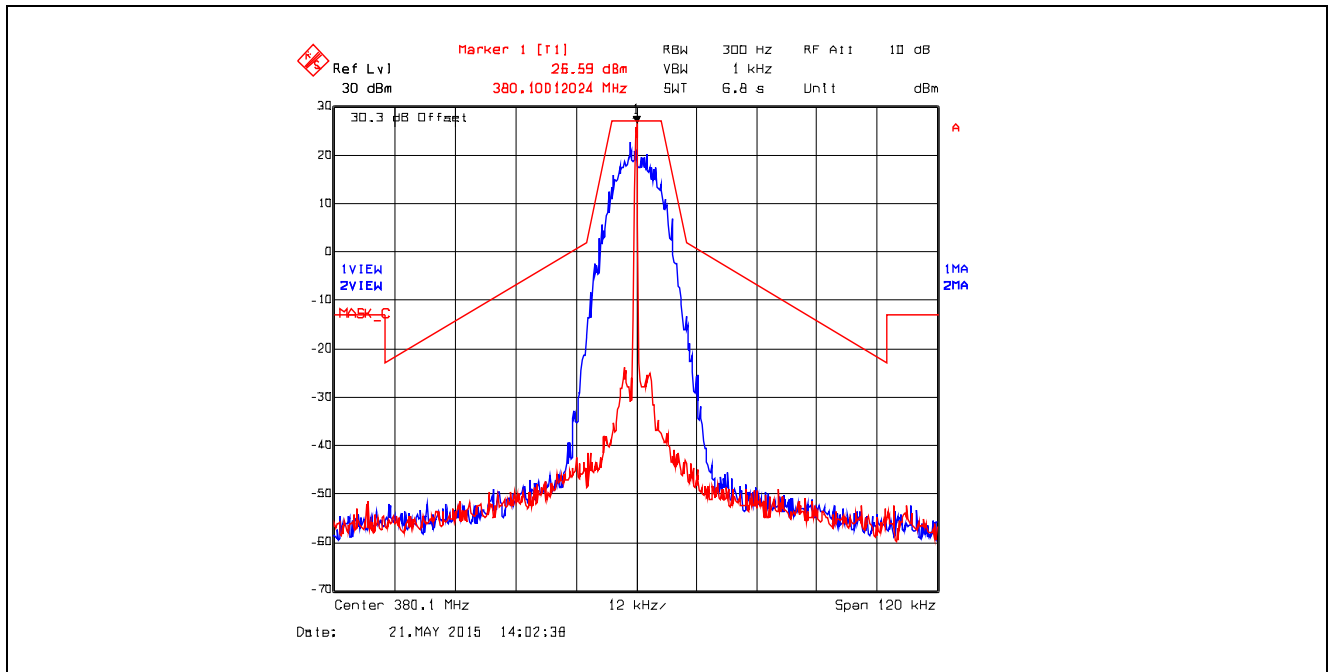

Plot 5.4.4.3.3. Emission Mask C, Digital at 19.2 kbps, 390.0 MHz, High Power

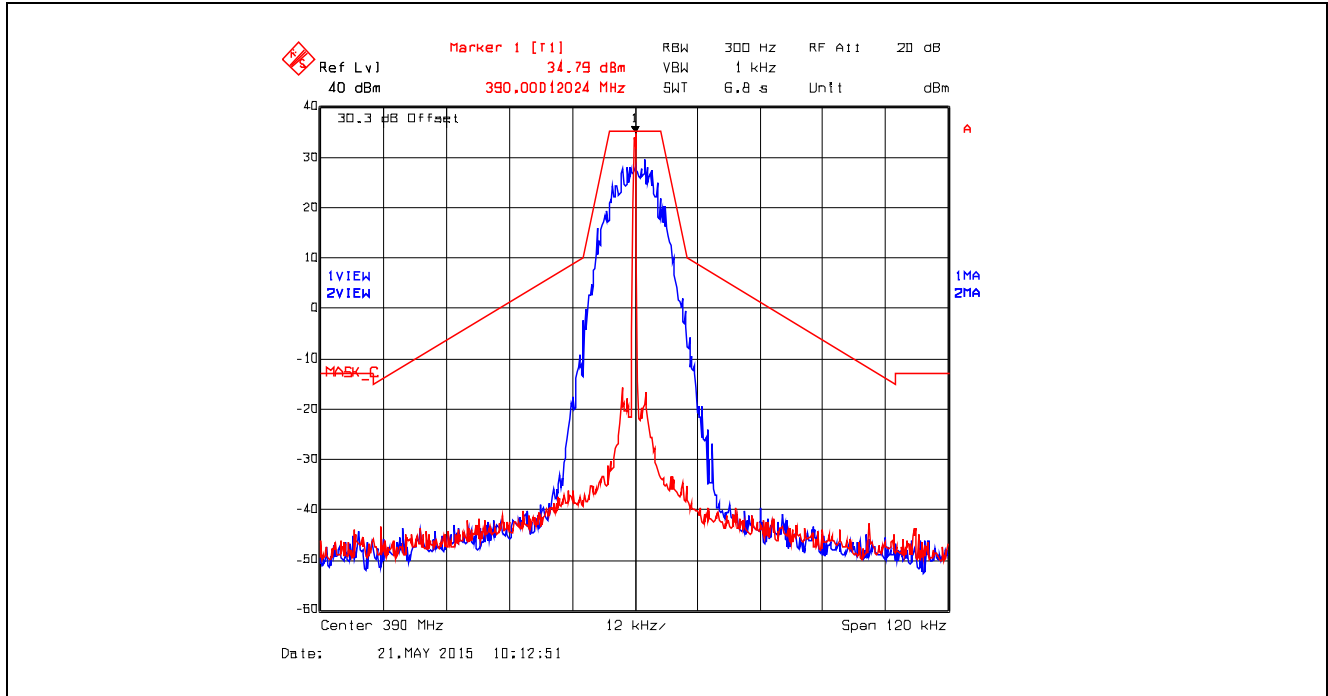

Plot 5.4.4.3.4. Emission Mask C, Digital at 19.2 kbps, 390.0 MHz, Low Power

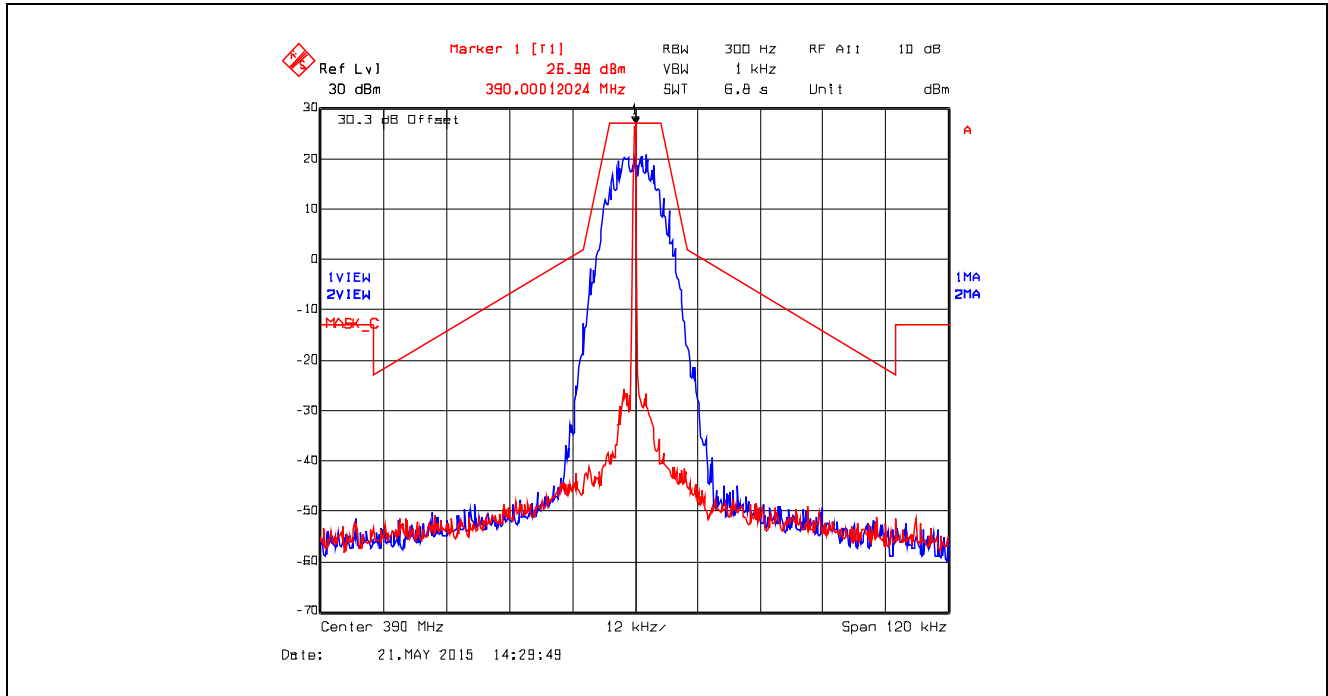

Plot 5.4.4.3.5. Emission Mask C, Digital at 19.2 kbps, 399.9 MHz, High Power

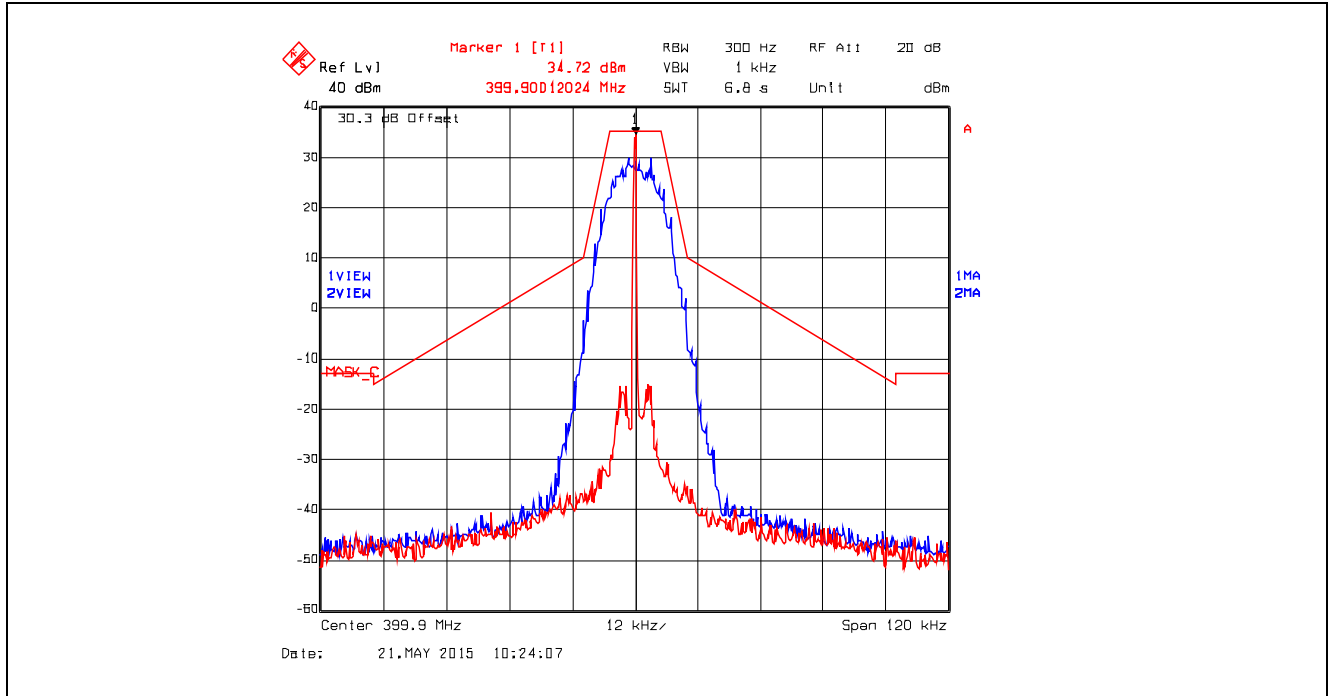

Plot 5.4.4.3.6. Emission Mask C, Digital at 19.2 kbps, 399.9 MHz, Low Power

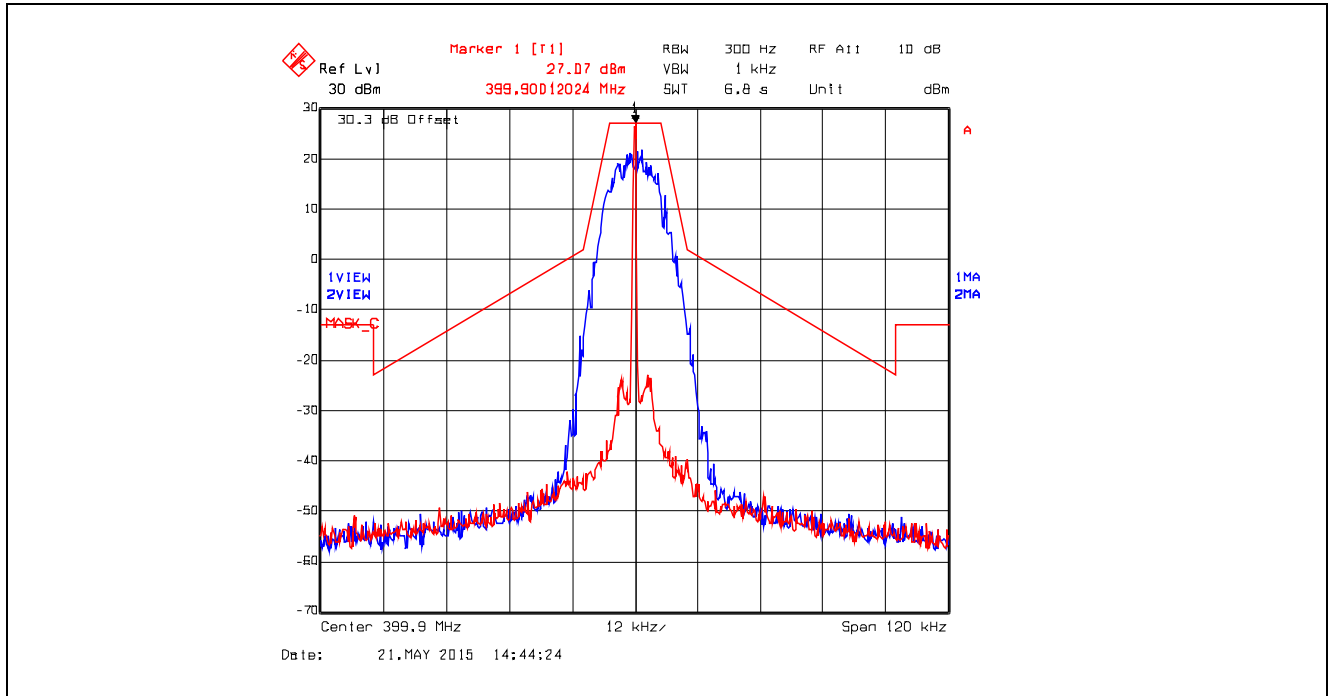

Plot 5.4.4.3.7. Emission Mask C, Digital at 19.2 kbps, 406.2 MHz, High Power

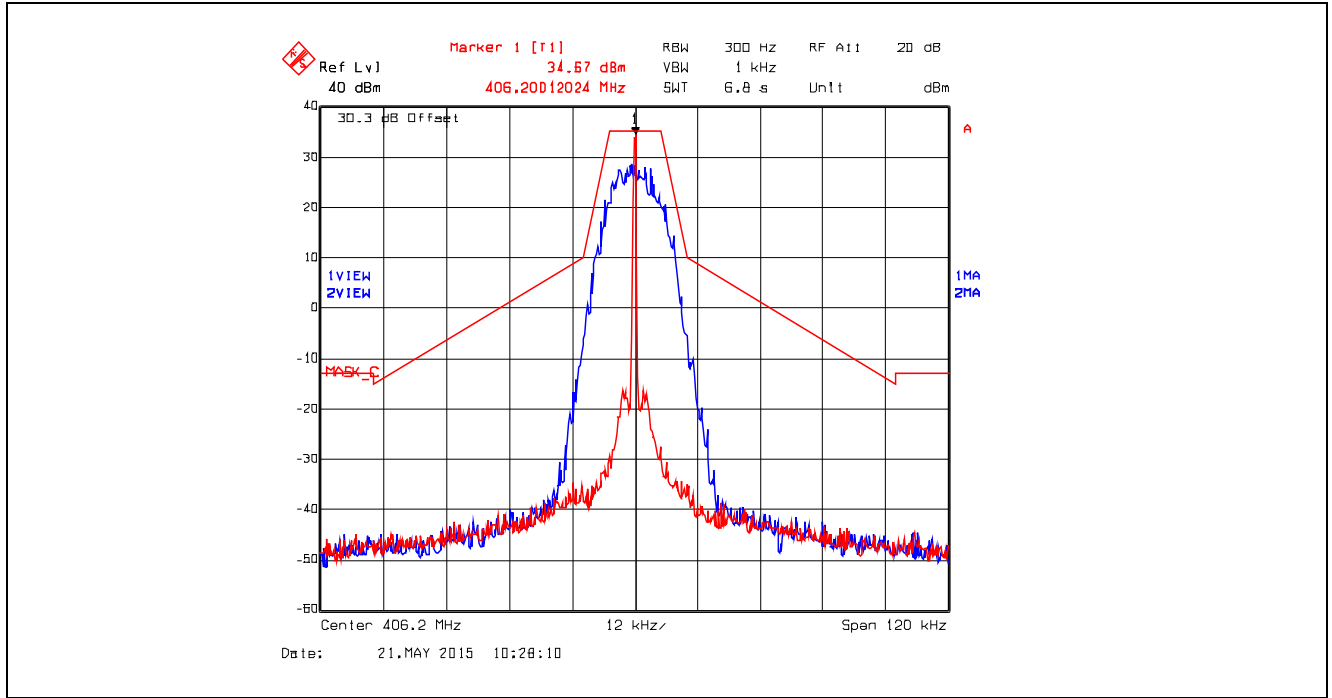

Plot 5.4.4.3.8. Emission Mask C, Digital at 19.2 kbps, 406.2 MHz, Low Power

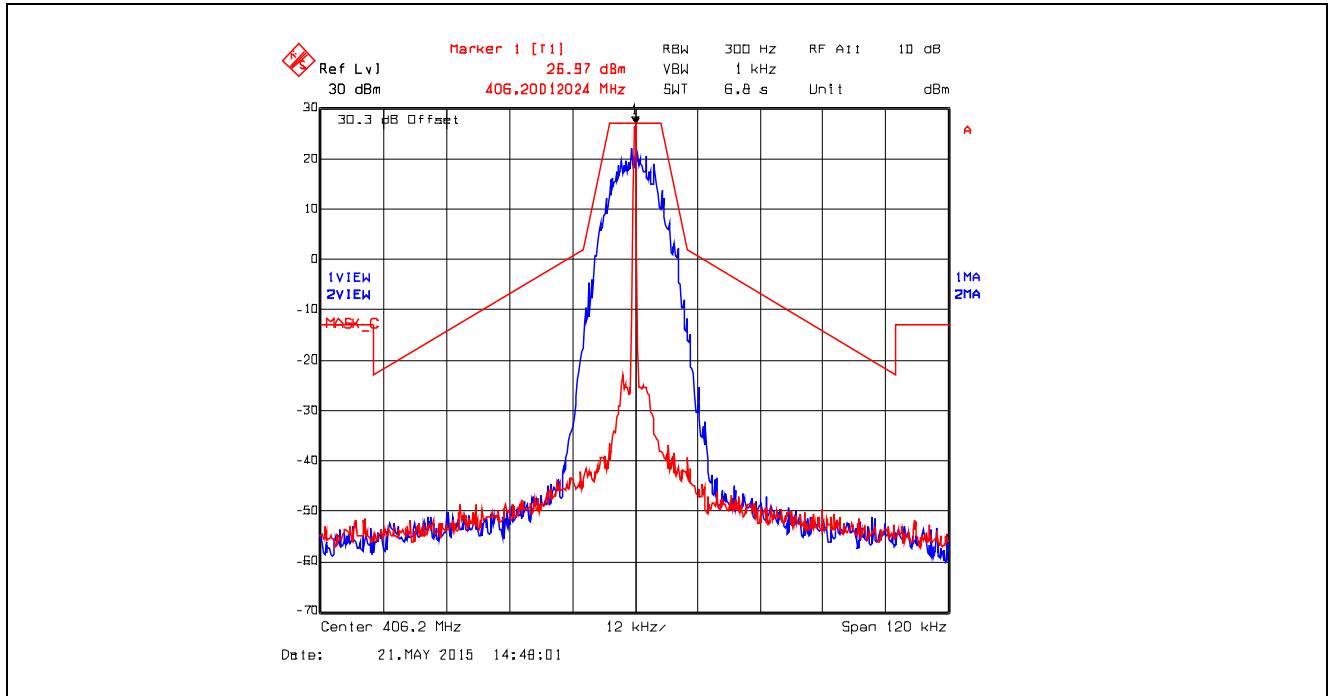

Plot 5.4.4.3.9. Emission Mask C, Digital at 19.2 kbps, 415.0 MHz, High Power

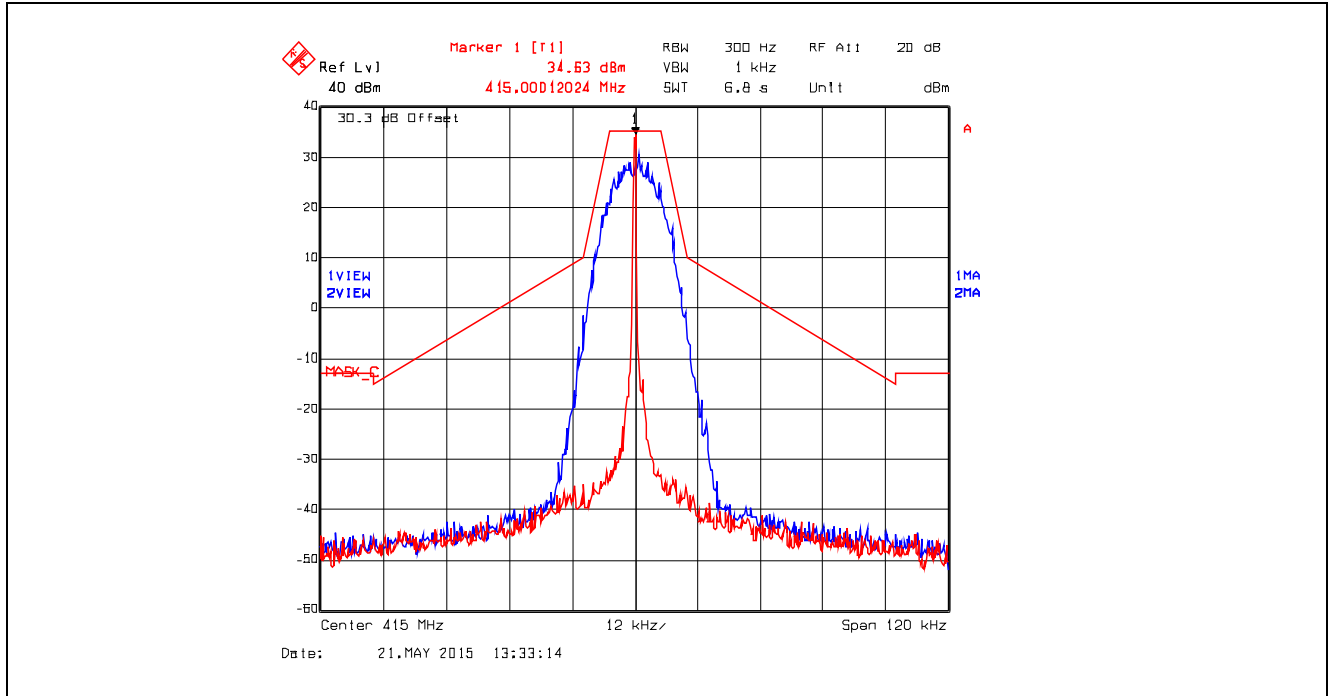

Plot 5.4.4.3.10. Emission Mask C, Digital at 19.2 kbps, 415.0 MHz, Low Power

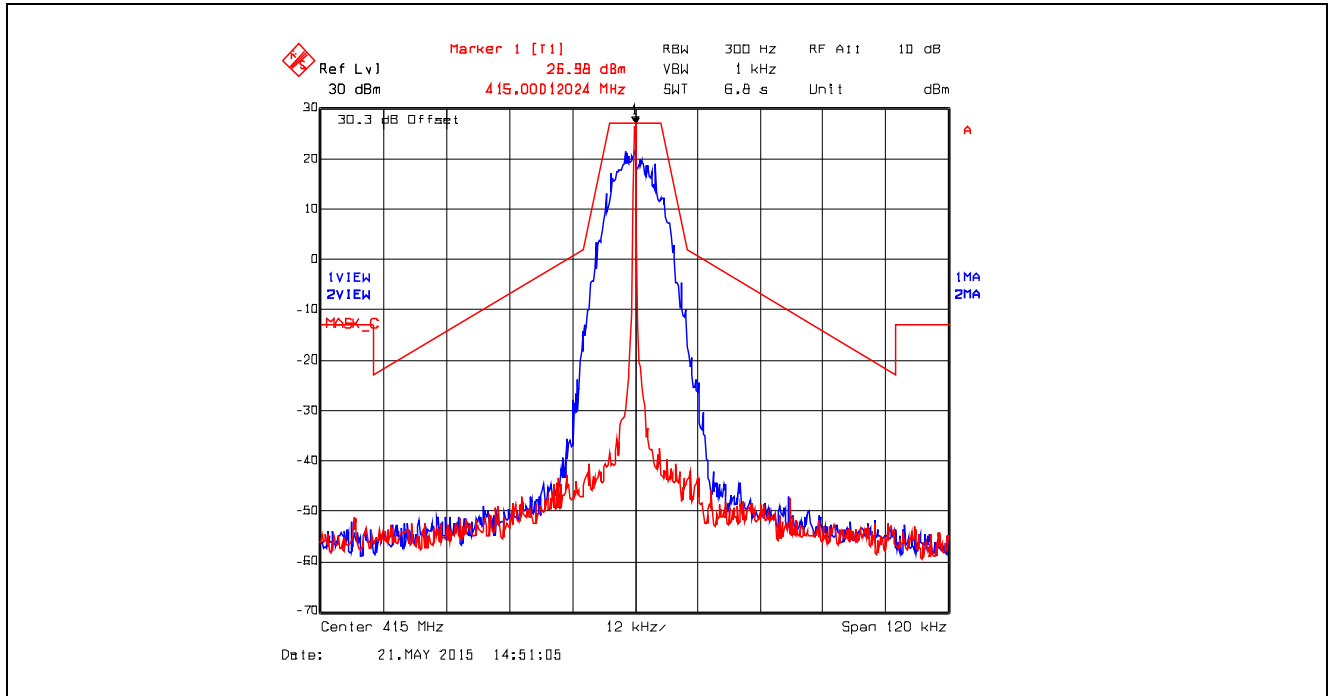

Plot 5.4.4.3.11. Emission Mask C, Digital at 19.2 kbps, 429.9 MHz, High Power

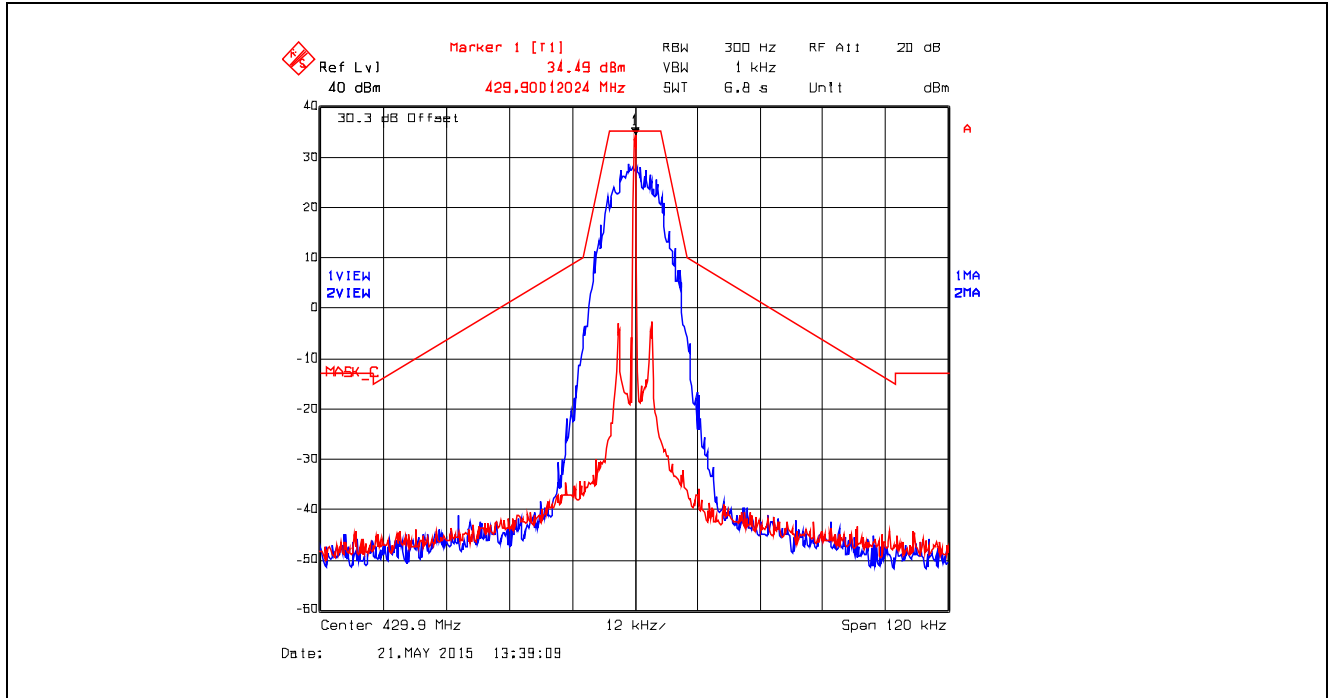

Plot 5.4.4.3.12. Emission Mask C, Digital at 19.2 kbps, 429.9 MHz, Low Power

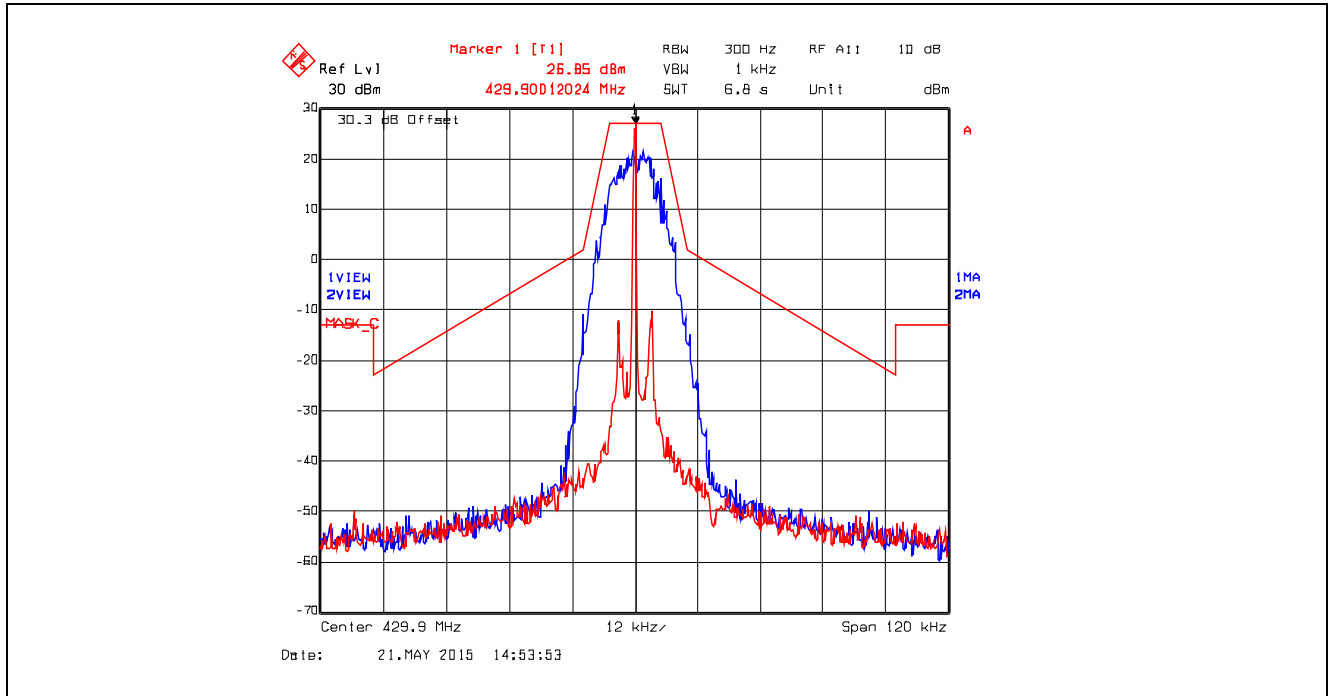

Plot 5.4.4.3.13. Emission Mask C, Digital at 19.2 kbps, 450.1 MHz, High Power

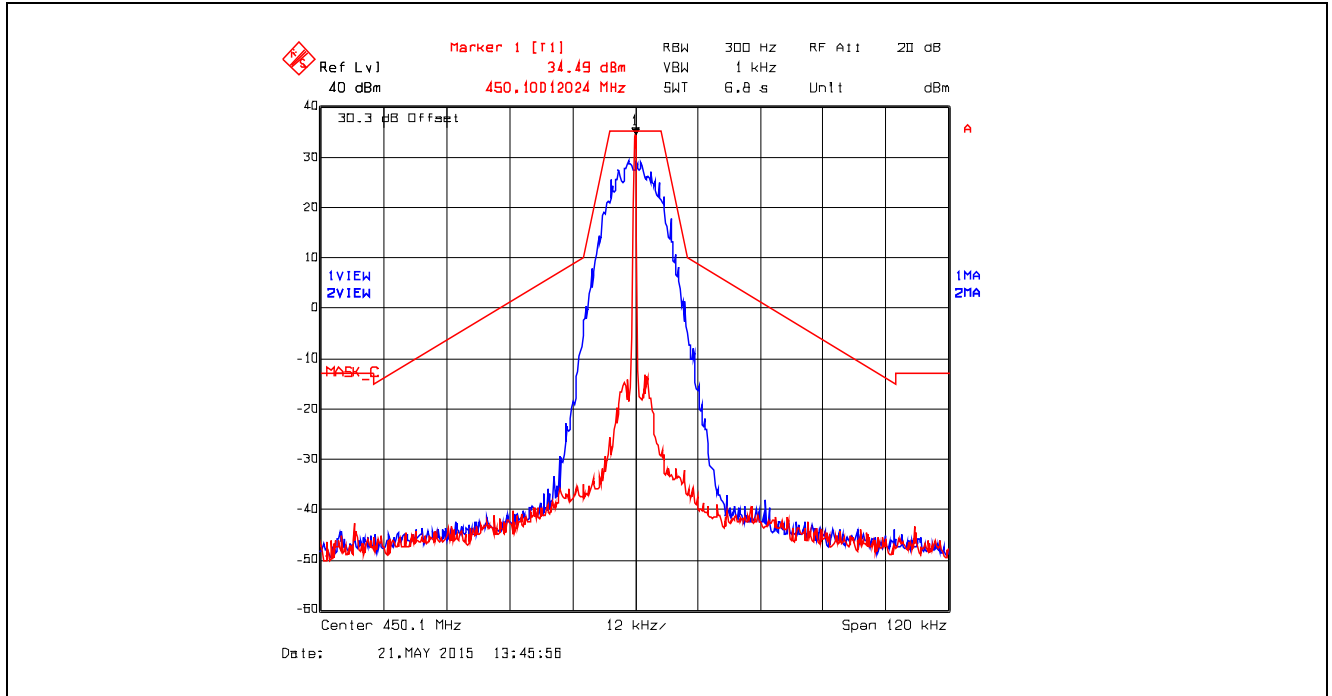

Plot 5.4.4.3.14. Emission Mask C, Digital at 19.2 kbps, 450.1 MHz, Low Power

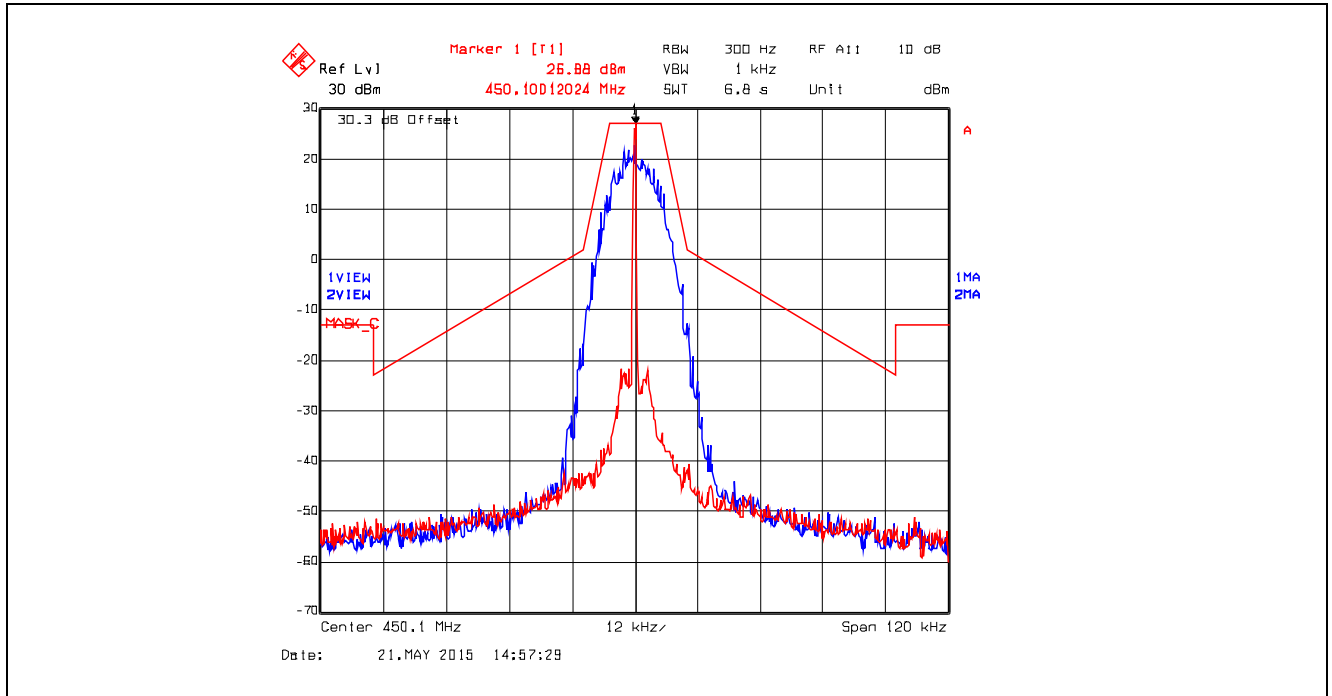

Plot 5.4.4.3.15. Emission Mask C, Digital at 19.2 kbps, 470.0 MHz, High Power

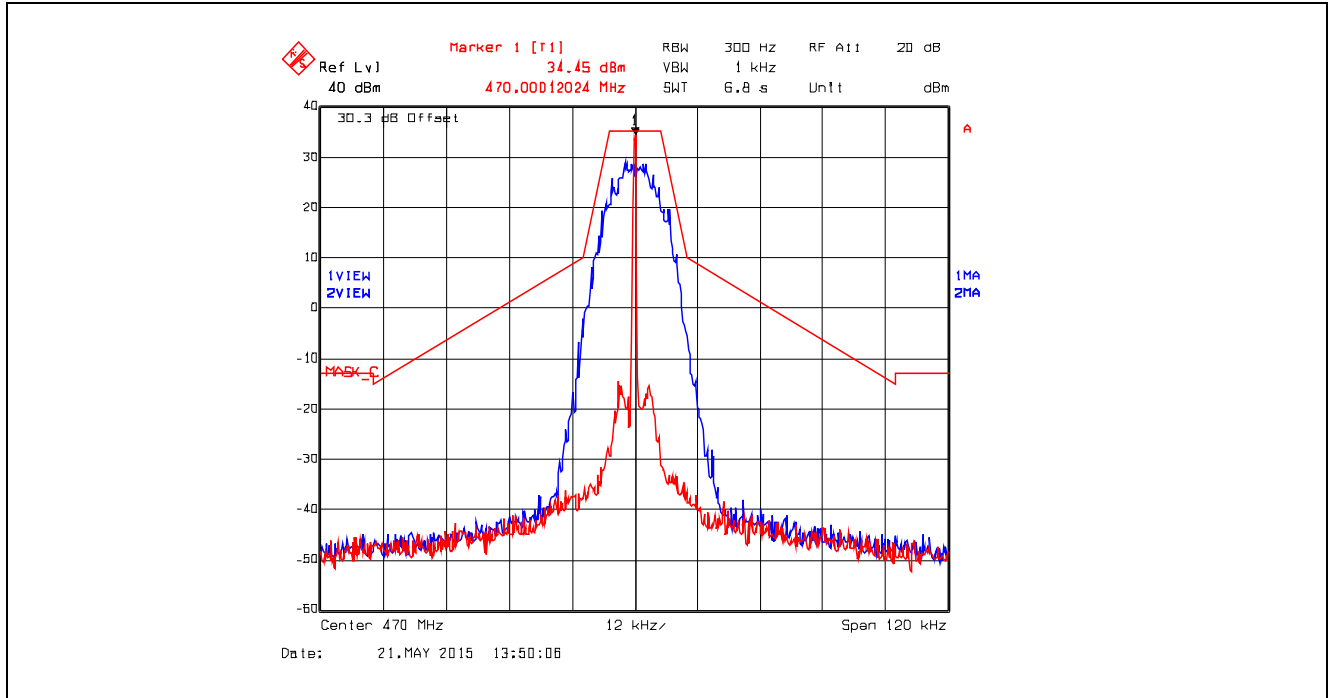

Plot 5.4.4.3.16. Emission Mask C, Digital at 19.2 kbps, 470.0 MHz, Low Power

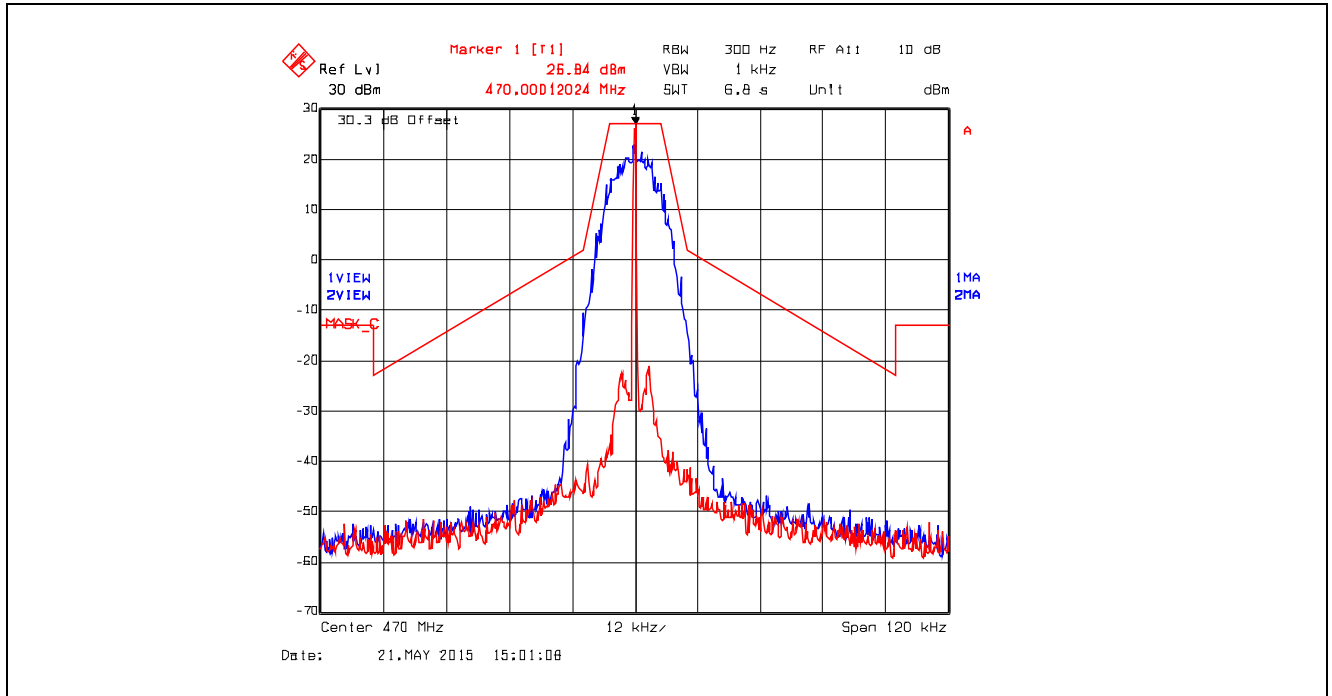

Plot 5.4.4.3.17. Emission Mask C, Digital at 19.2 kbps, 511.9 MHz, High Power

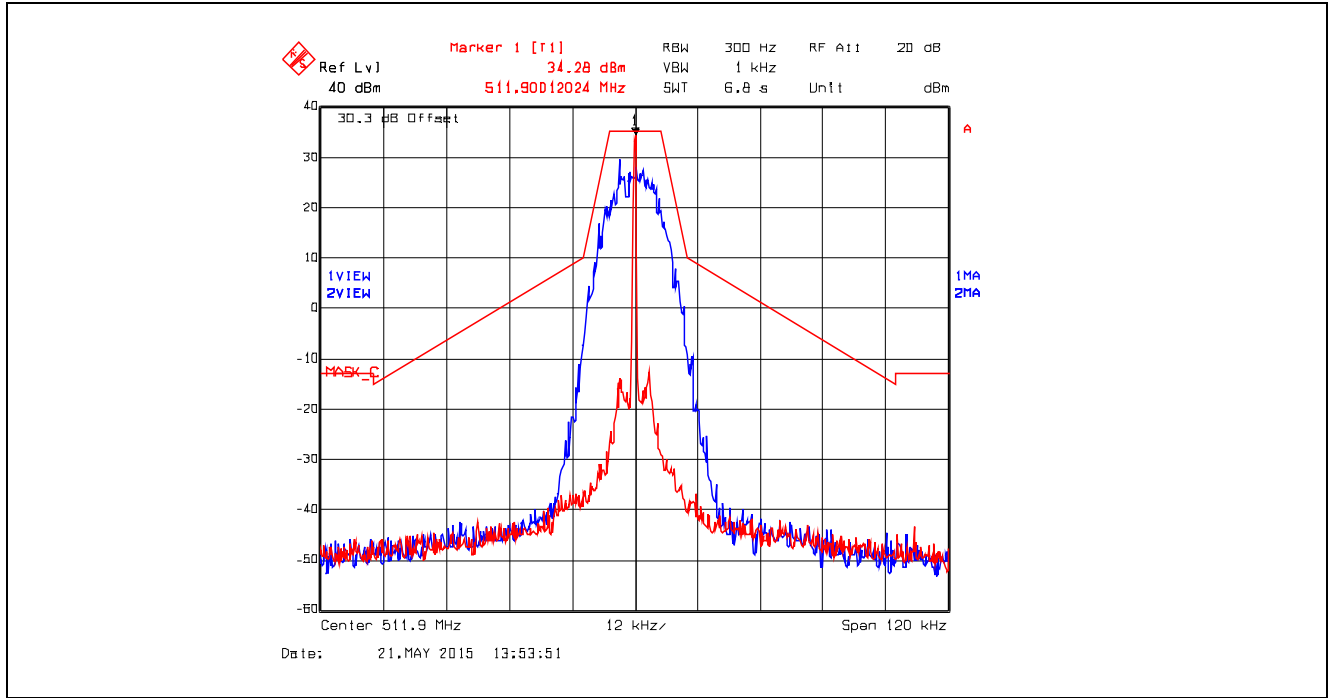

Plot 5.4.4.3.18. Emission Mask C, Digital at 19.2 kbps, 511.9 MHz, Low Power

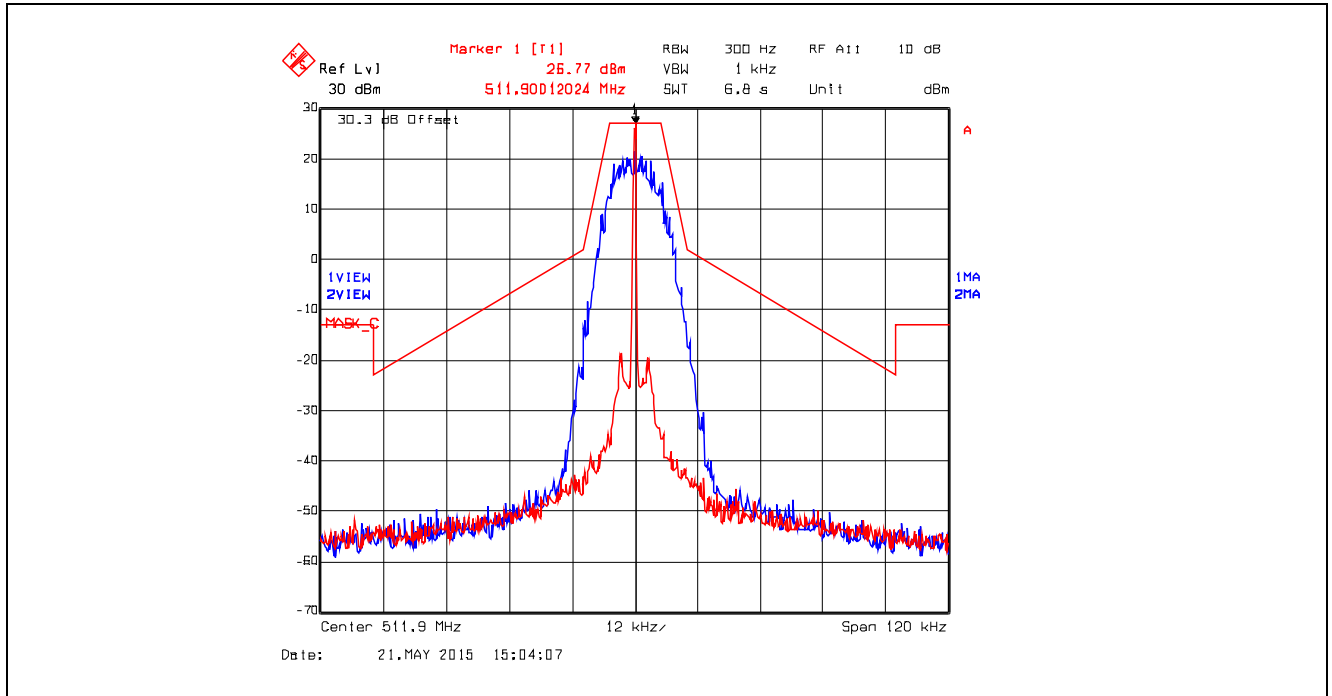

5.4.4.4. Emission Mask D, Analog

Plot 5.4.4.4.1. Emission Mask D, Analog, 381.1 MHz, High Power

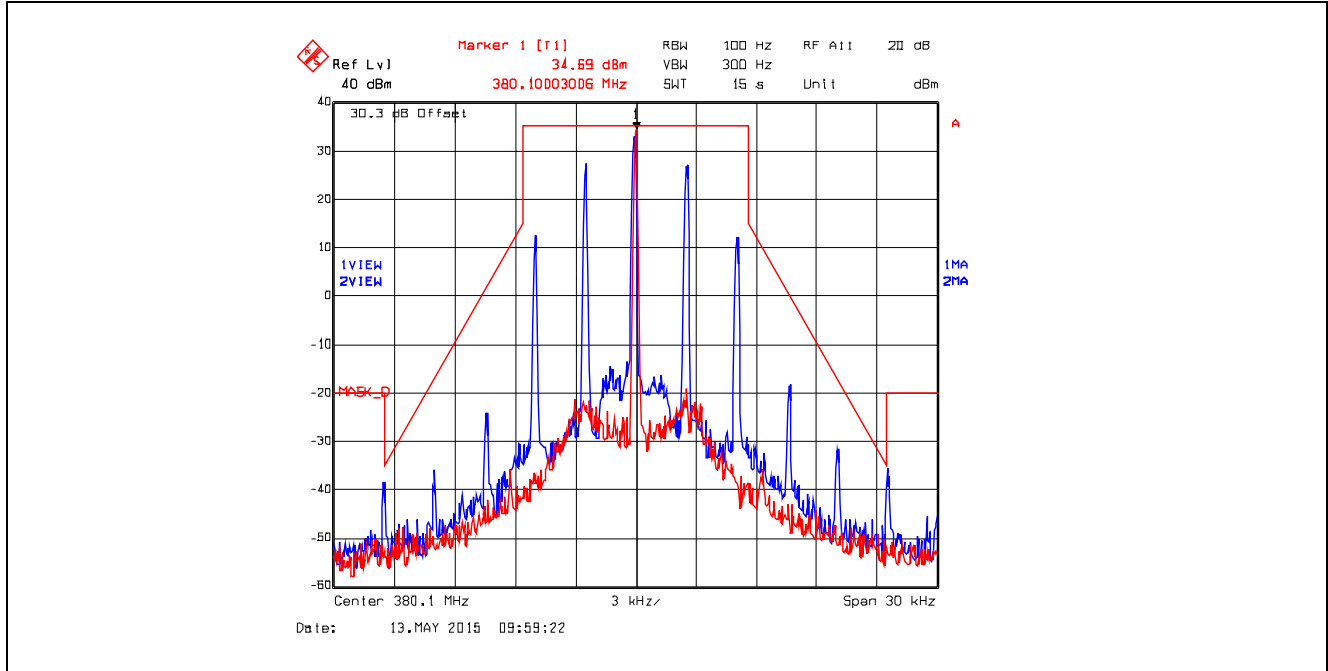

Plot 5.4.4.4.2. Emission Mask D, Analog, 381.1 MHz, Low Power

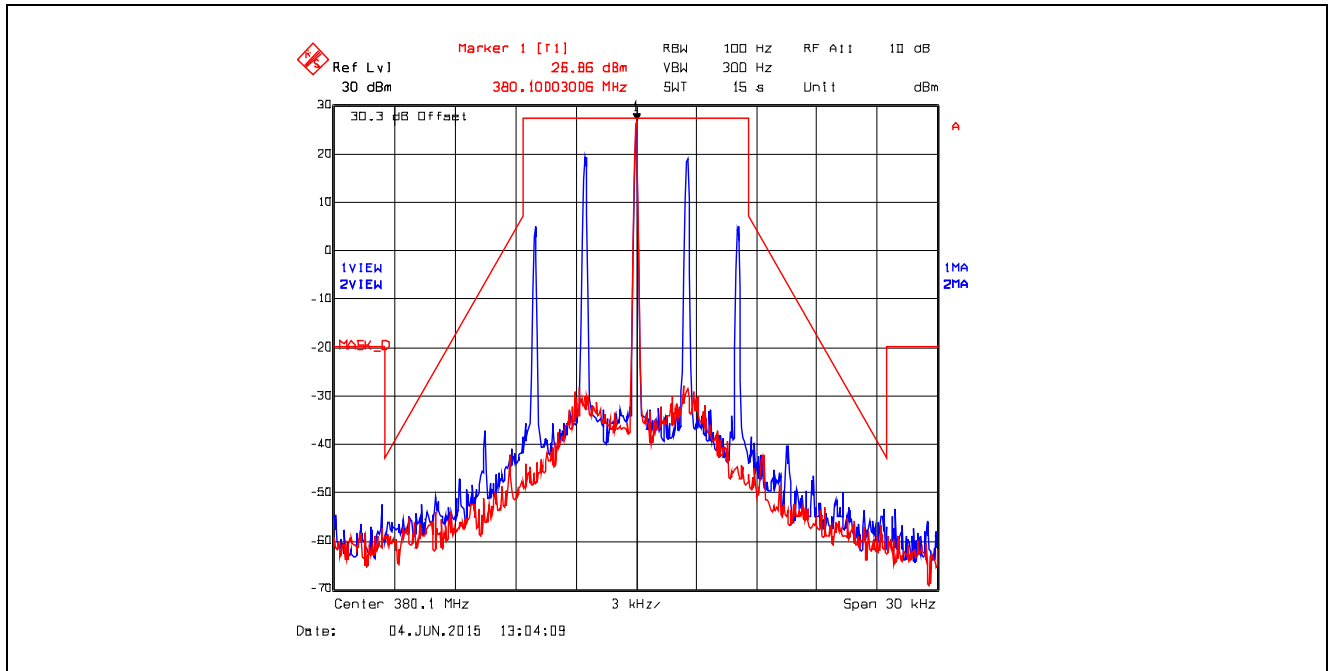

Plot 5.4.4.4.3. Emission Mask D, Analog, 390.0 MHz, High Power

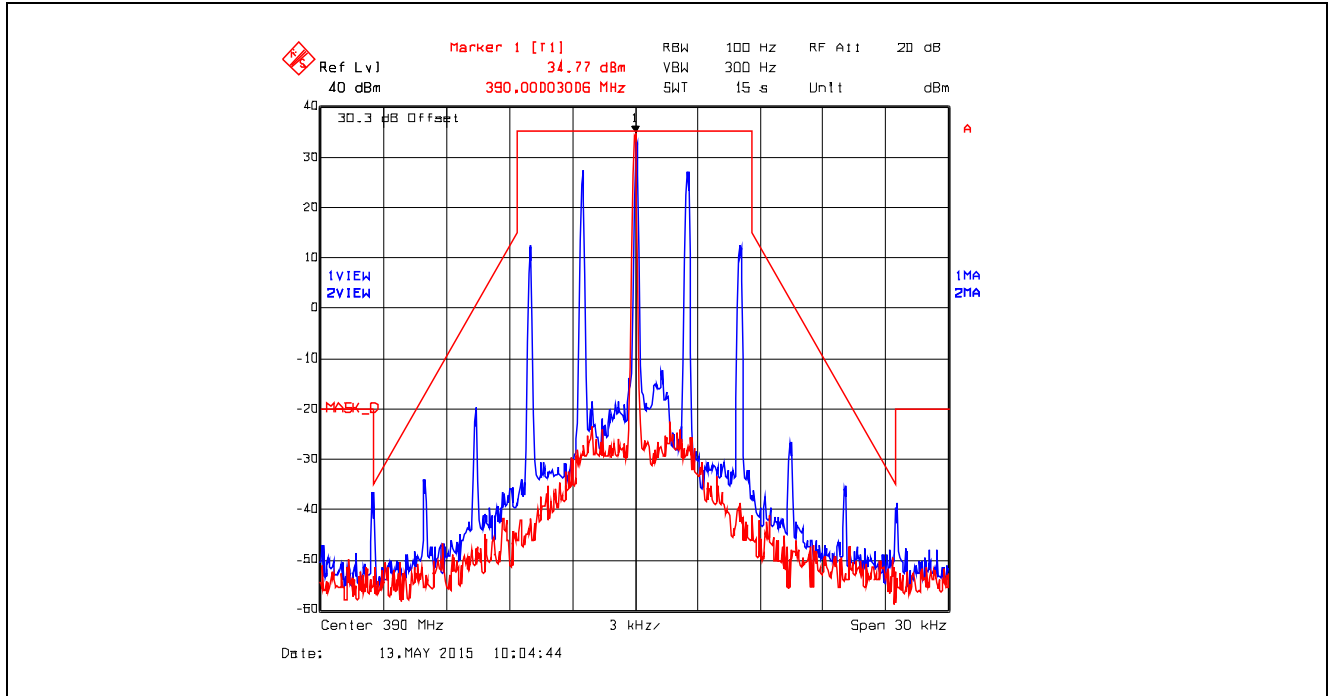

Plot 5.4.4.4.4. Emission Mask D, Analog, 390.0 MHz, Low Power

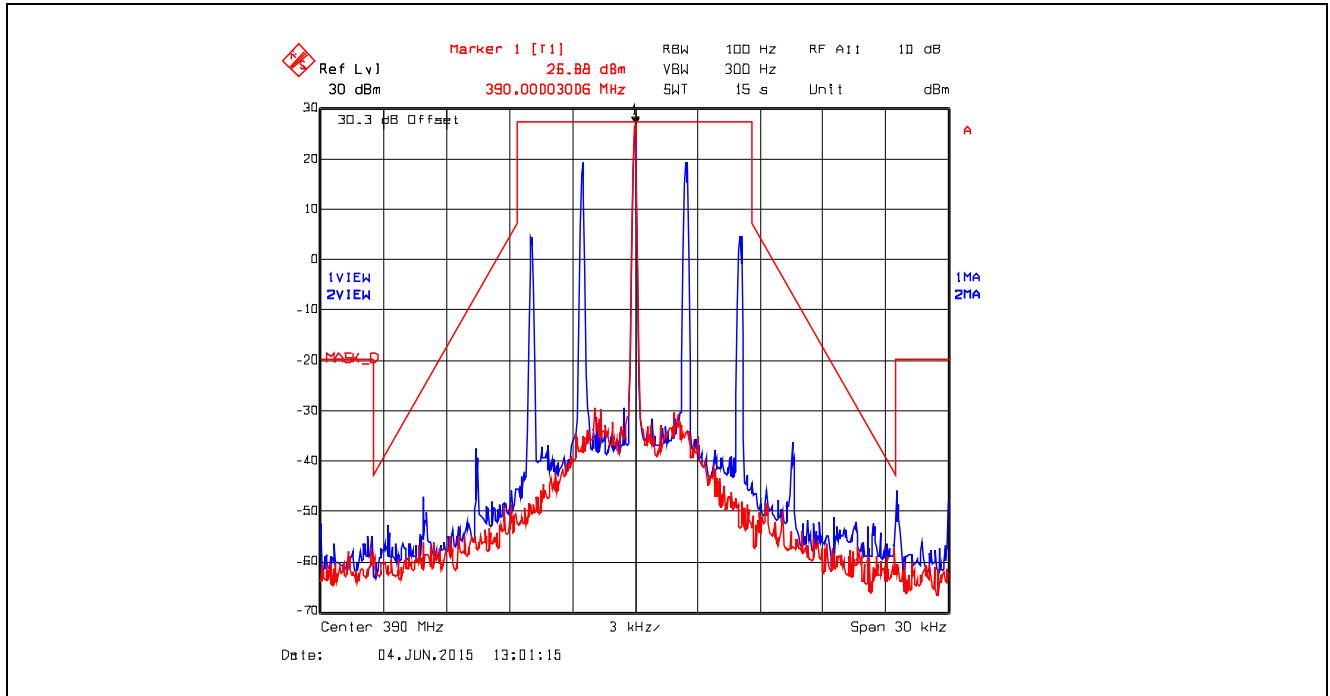

Plot 5.4.4.4.5. Emission Mask D, Analog, 399.9 MHz, High Power

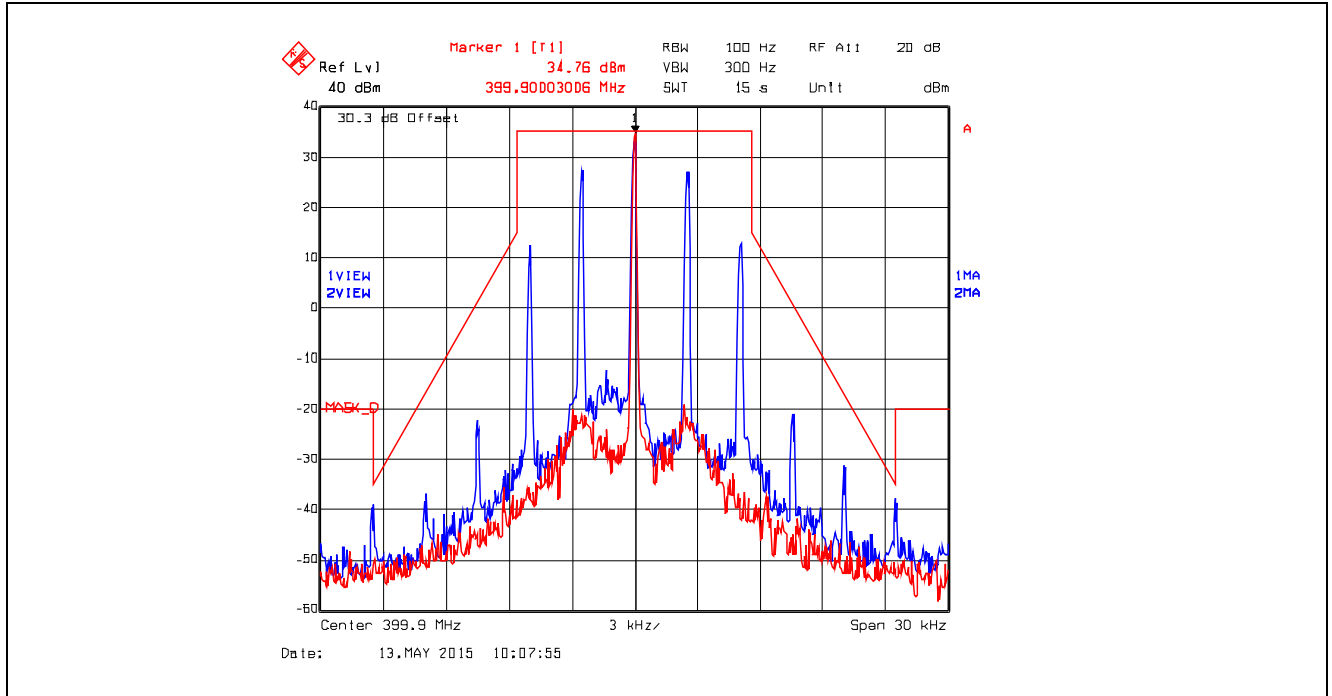

Plot 5.4.4.4.6. Emission Mask D, Analog, 399.9 MHz, Low Power

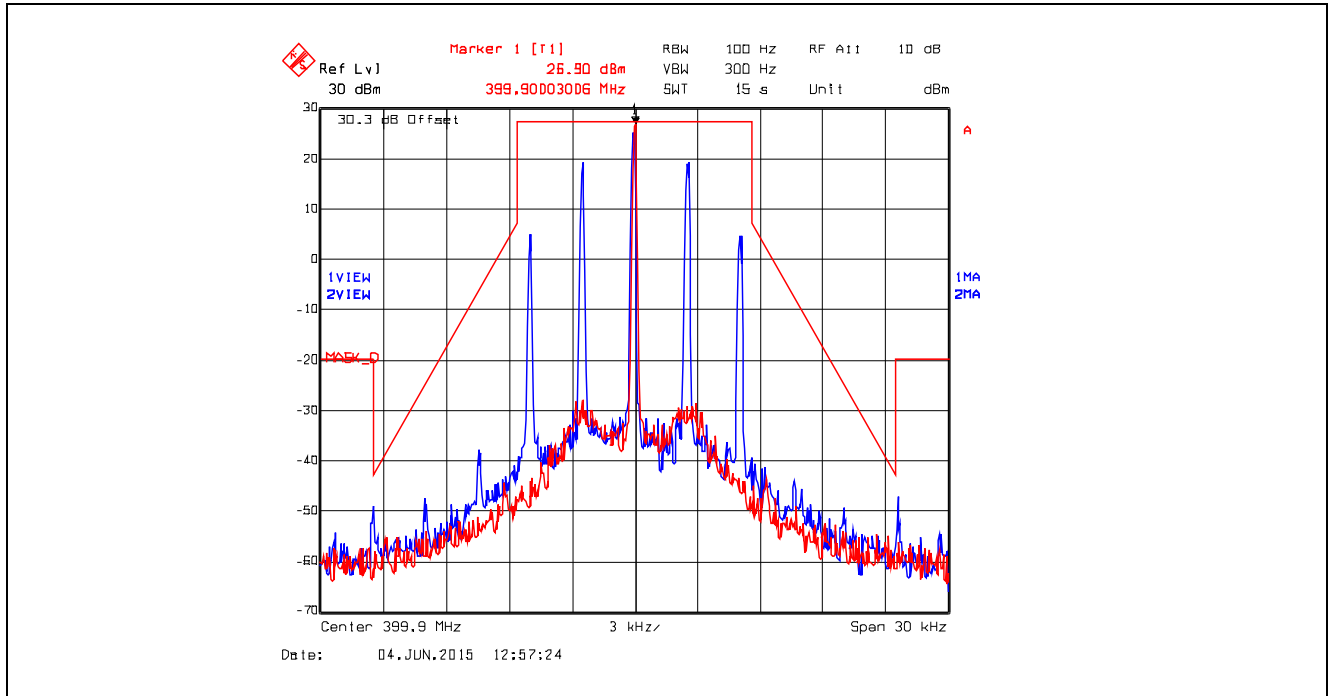

Plot 5.4.4.4.7. Emission Mask D, Analog, 406.2 MHz, High Power

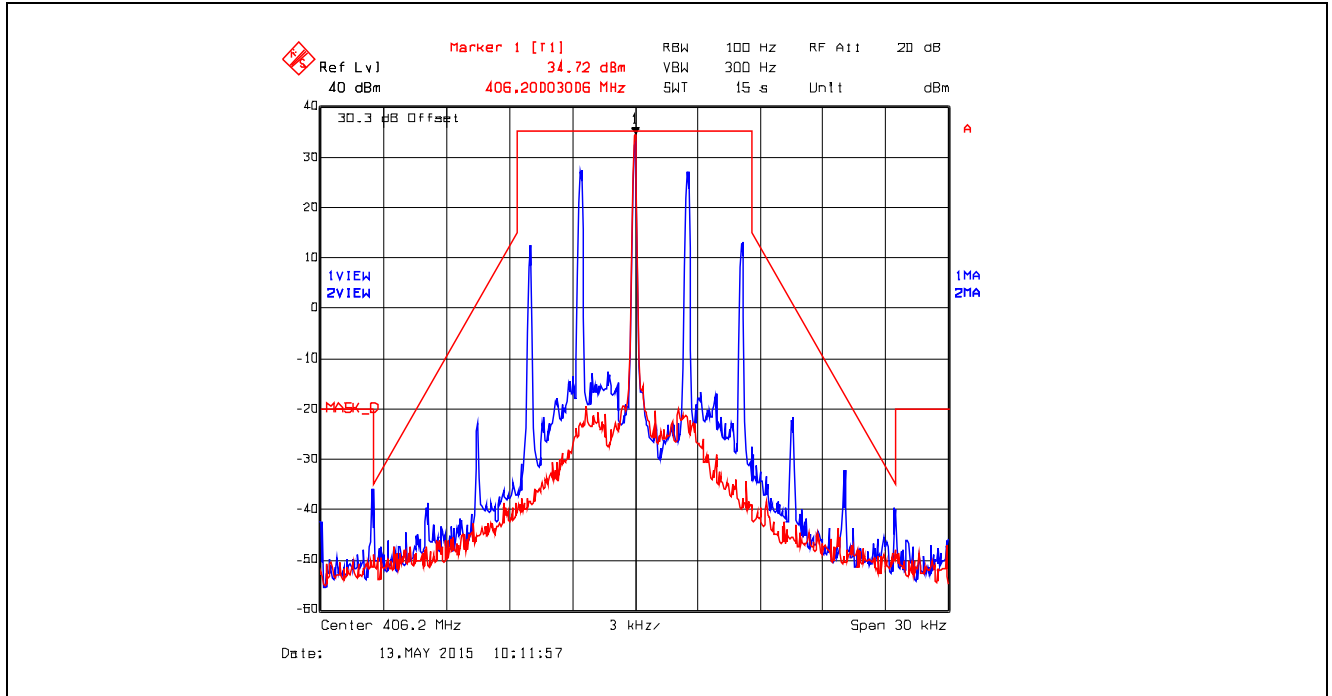

Plot 5.4.4.4.8. Emission Mask D, Analog, 406.2 MHz, Low Power

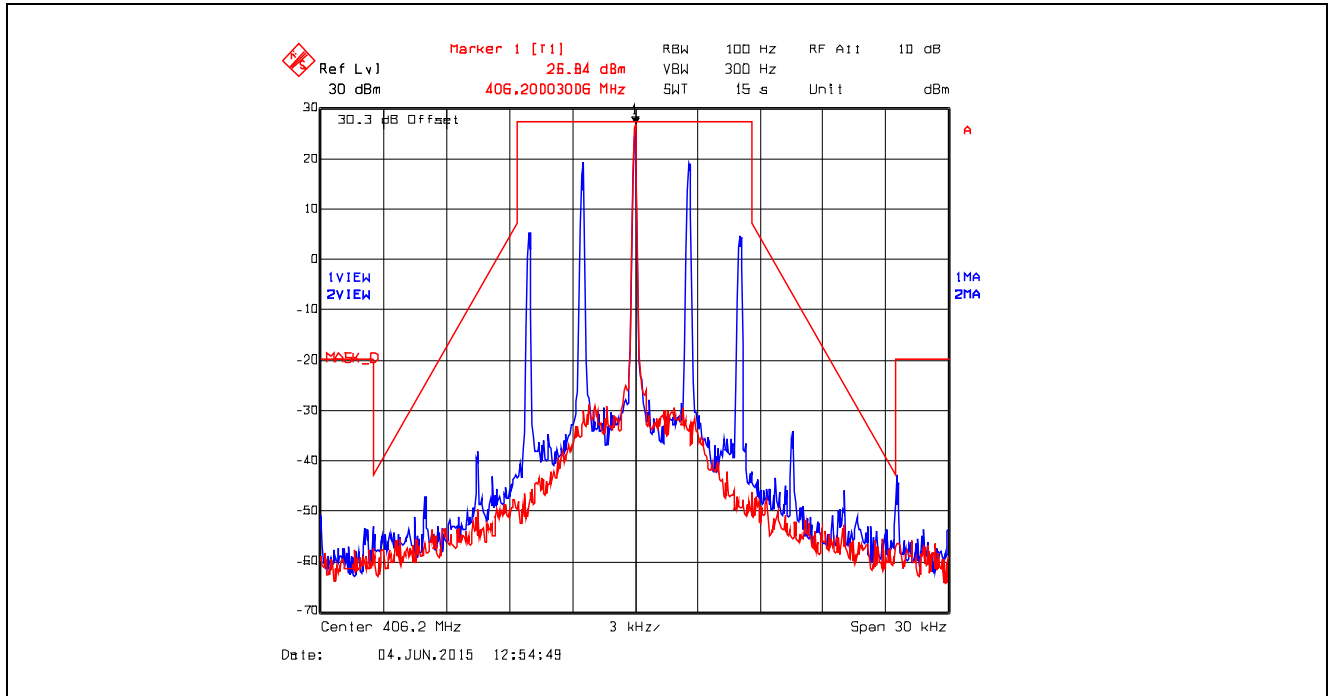

Plot 5.4.4.9. Emission Mask D, Analog, 415.0 MHz, High Power

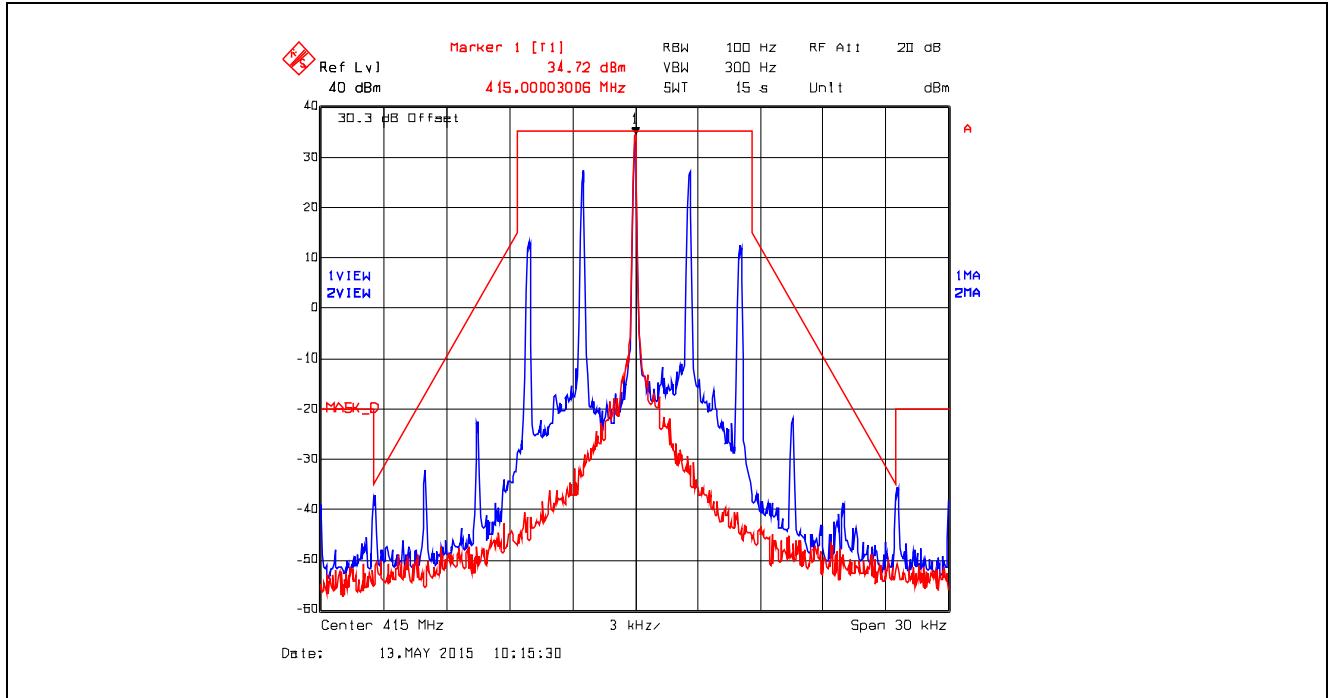

Plot 5.4.4.10. Emission Mask D, Analog, 415.0 MHz, Low Power

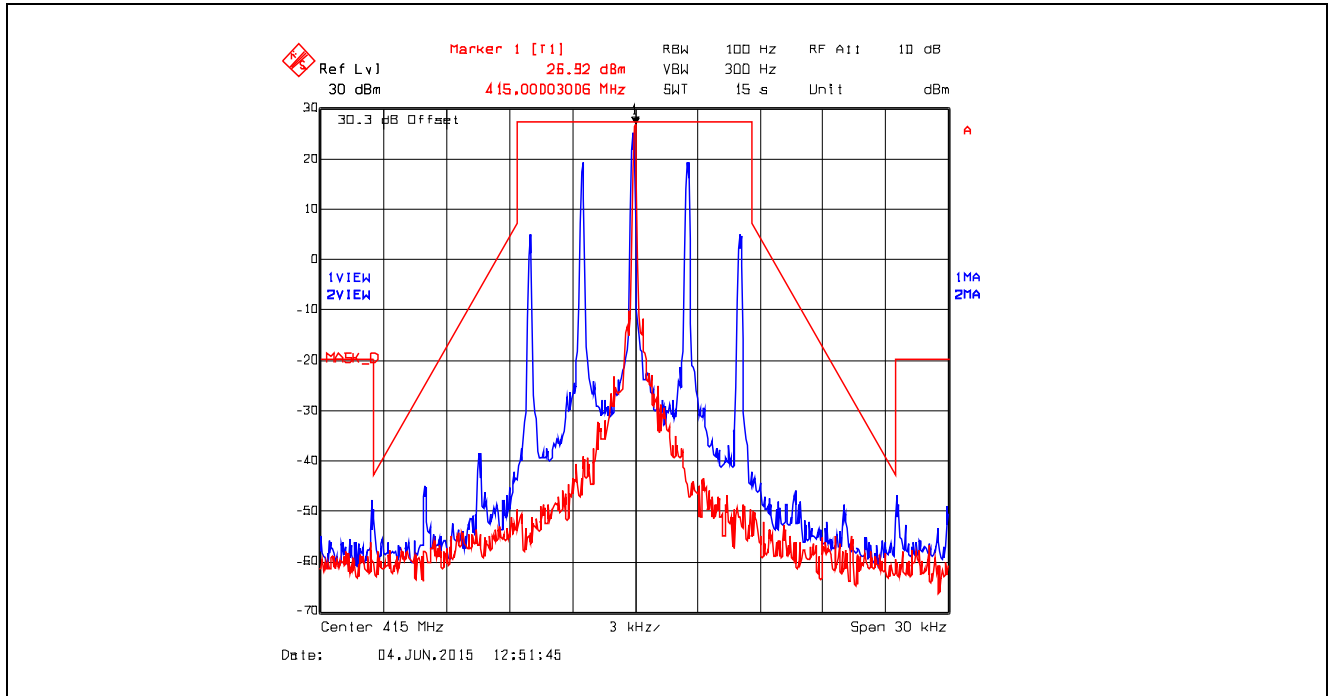

Plot 5.4.4.11. Emission Mask D, Analog, 429.9 MHz, High Power

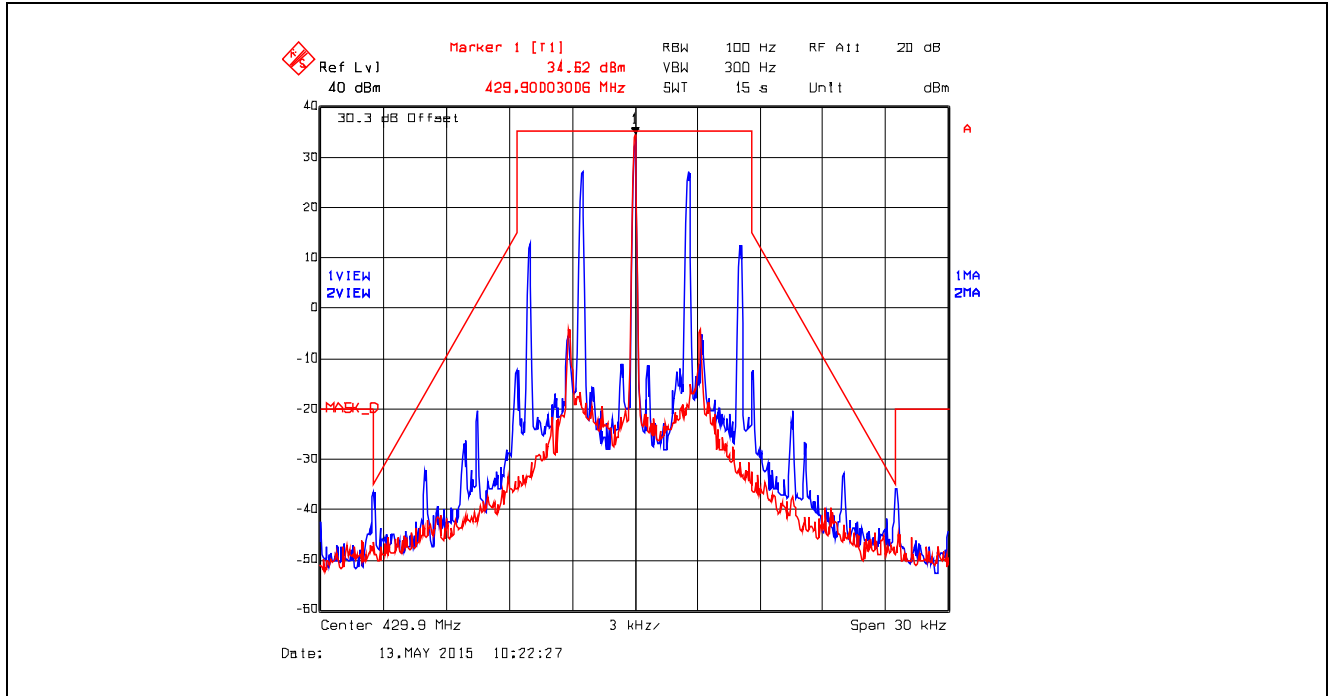

Plot 5.4.4.12. Emission Mask D, Analog, 429.9 MHz, Low Power

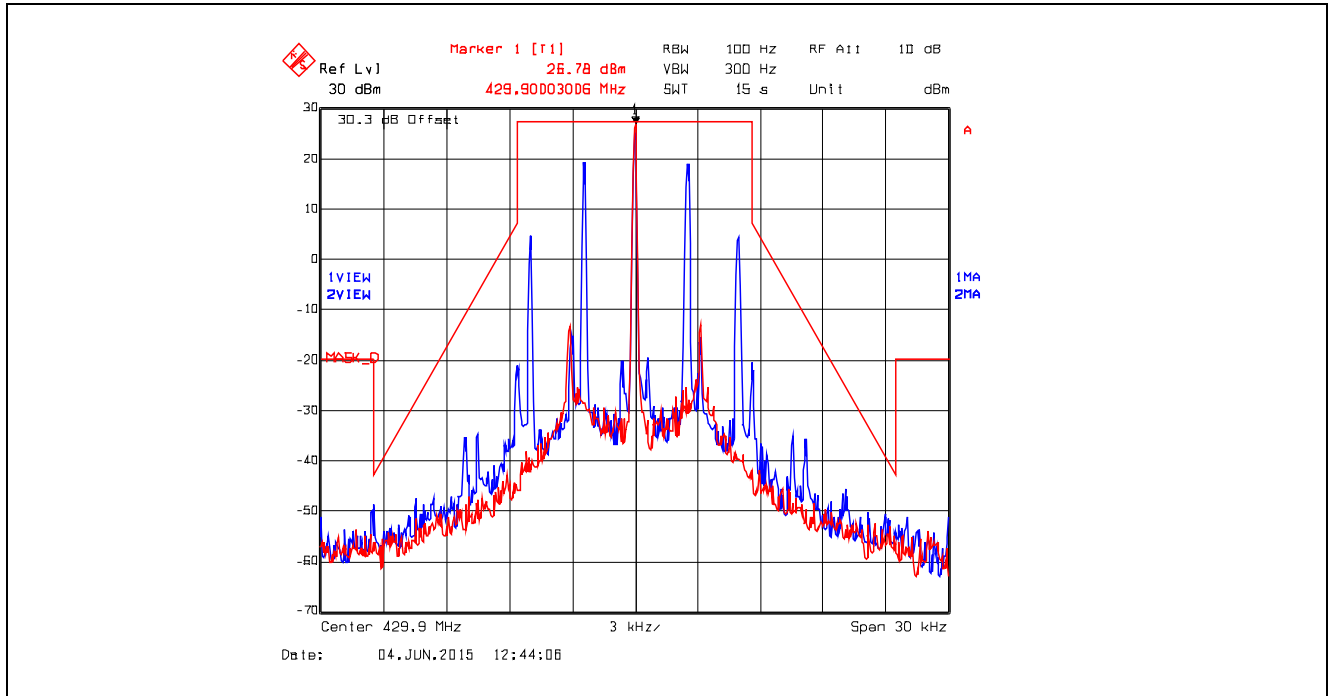

Plot 5.4.4.4.13. Emission Mask D, Analog, 450.1 MHz, High Power

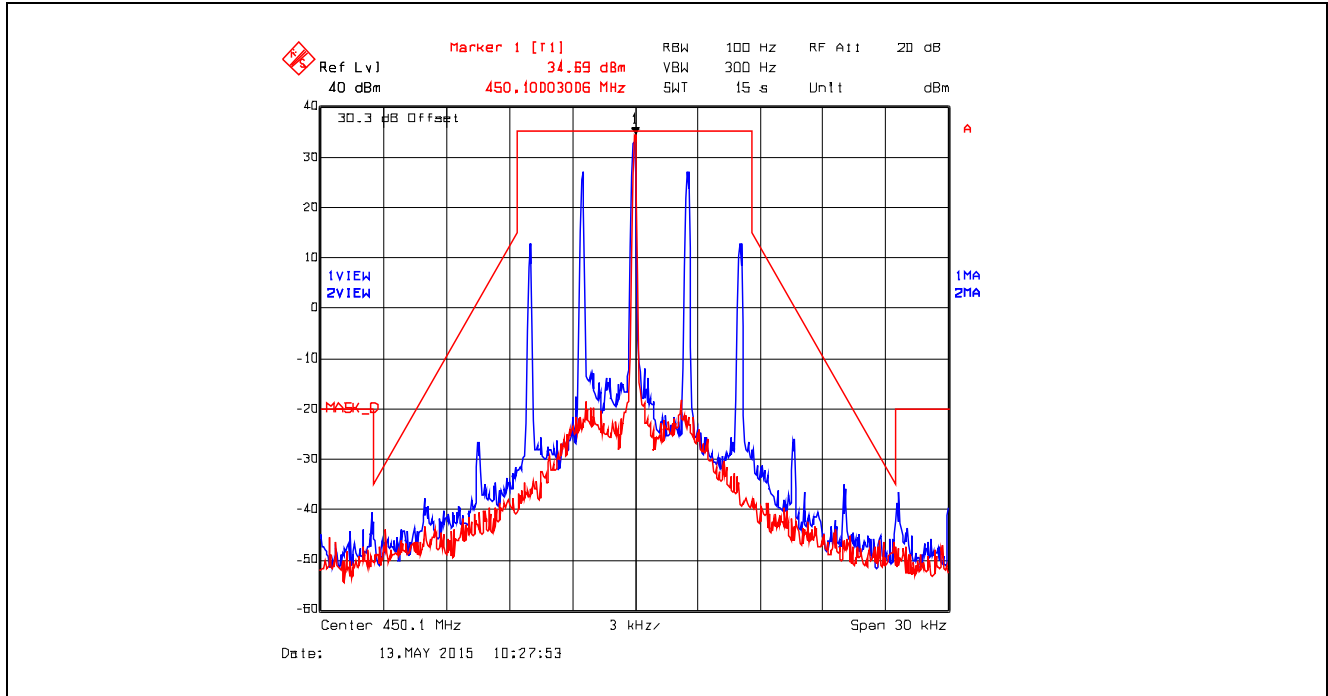

Plot 5.4.4.4.14. Emission Mask D, Analog, 450.1 MHz, Low Power

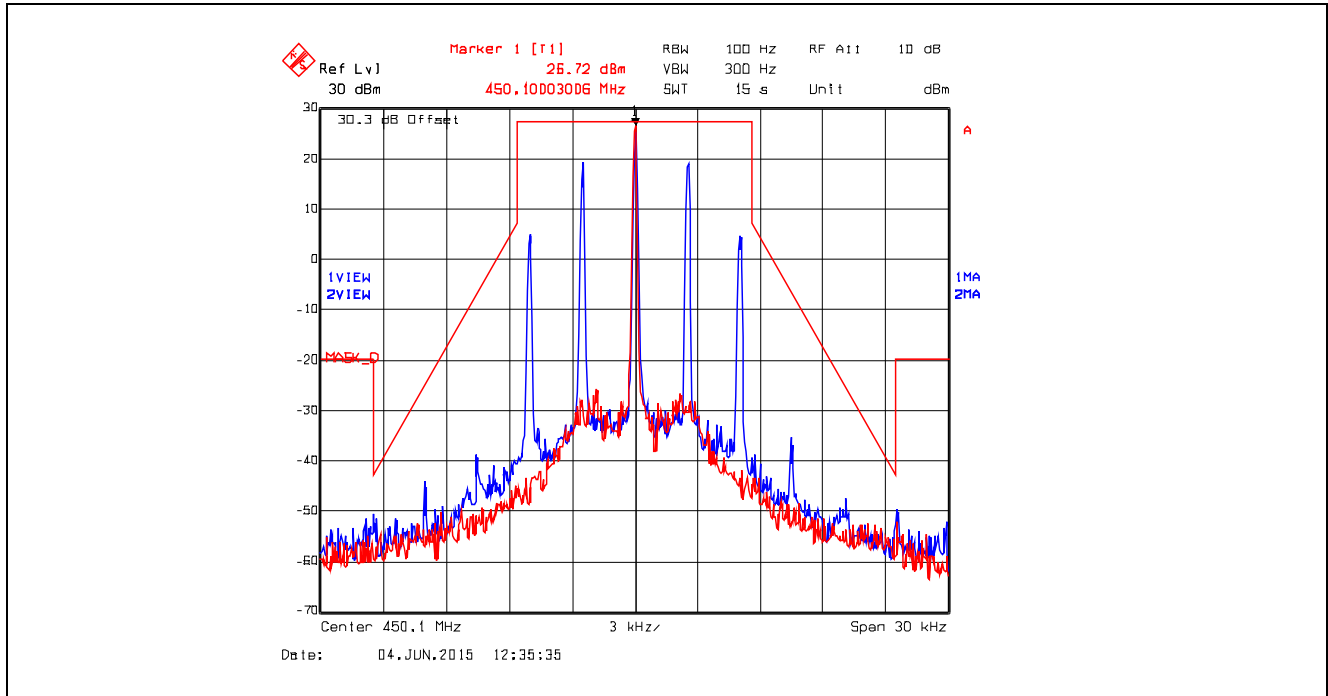

ULTRATECH GROUP OF LABS

3000 Bristol Circle, Oakville, Ontario, Canada L6H 6G4
Tel. #: 905-829-1570, Fax. #: 905-829-8050, Email: vic@ultratech-labs.com, Website: <http://www.ultratech-labs.com>

File #: 15FSG141_FCC90
July 8, 2015

All test results contained in this engineering test report are traceable to National Institute of Standards and Technology (NIST)

Plot 5.4.4.15. Emission Mask D, Analog, 470.0 MHz, High Power

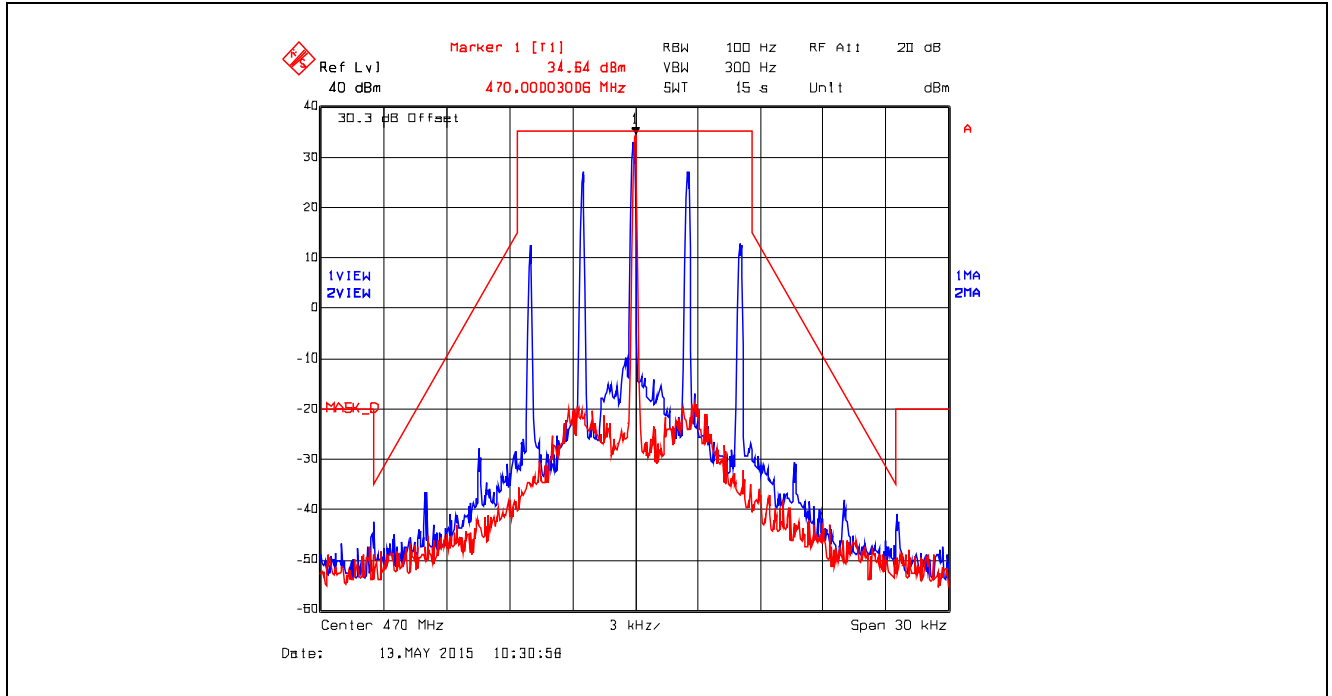

Plot 5.4.4.16. Emission Mask D, Analog, 470.0 MHz, Low Power

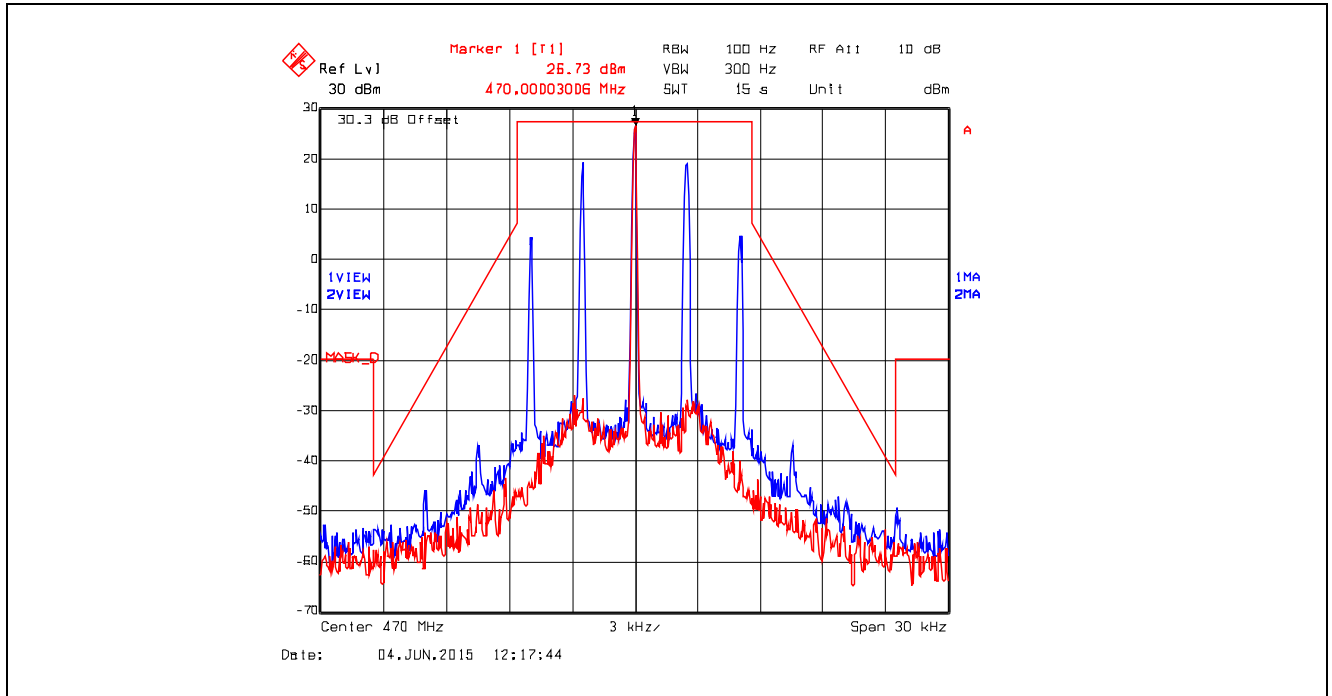

ULTRATECH GROUP OF LABS

3000 Bristol Circle, Oakville, Ontario, Canada L6H 6G4
Tel. #: 905-829-1570, Fax. #: 905-829-8050, Email: vic@ultratech-labs.com, Website: <http://www.ultratech-labs.com>

File #: 15FSG141_FCC90
July 8, 2015

All test results contained in this engineering test report are traceable to National Institute of Standards and Technology (NIST)

Plot 5.4.4.17. Emission Mask D, Analog, 511.9 MHz, High Power

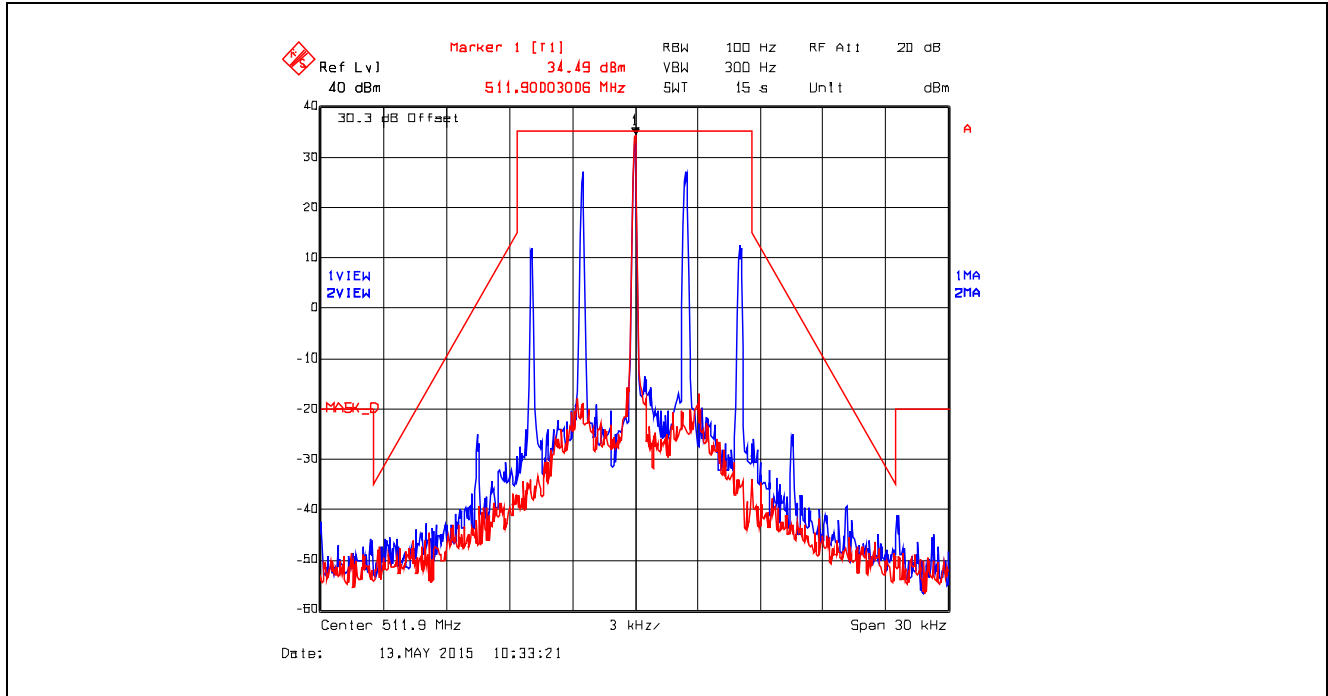

Plot 5.4.4.18. Emission Mask D, Analog, 511.9 MHz, Low Power

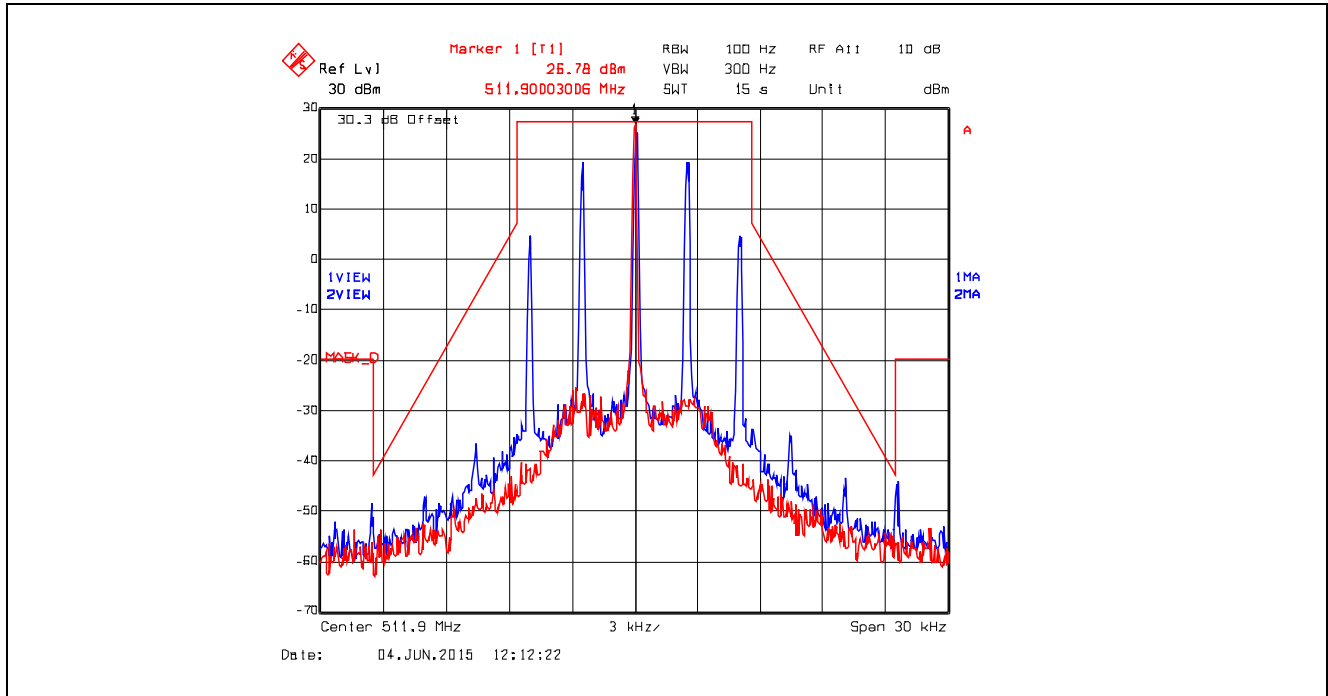

5.4.4.5. Emission Mask D, Digital at 9.6 kbps

Plot 5.4.4.5.1. Emission Mask D, Digital at 9.6 kbps, 381.1 MHz, High Power

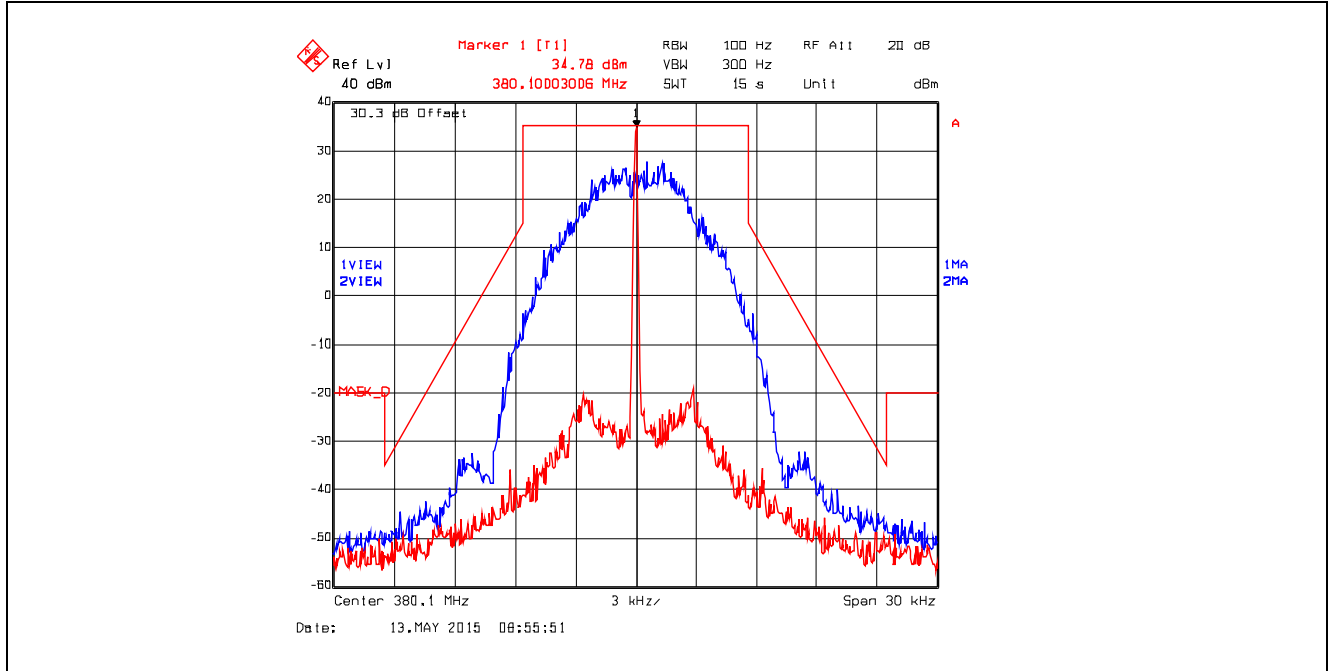

Plot 5.4.4.5.2. Emission Mask D, Digital at 9.6 kbps, 381.1 MHz, Low Power

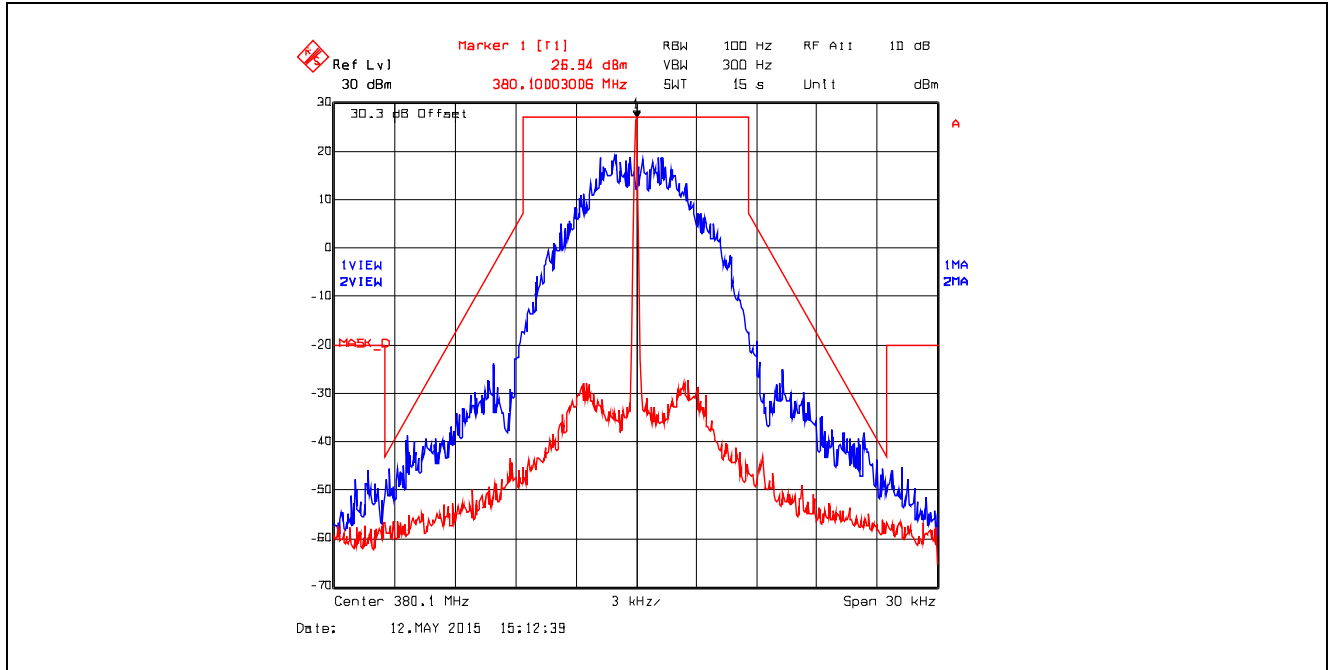

Plot 5.4.4.5.3. Emission Mask D, Digital at 9.6 kbps, 390.0 MHz, High Power

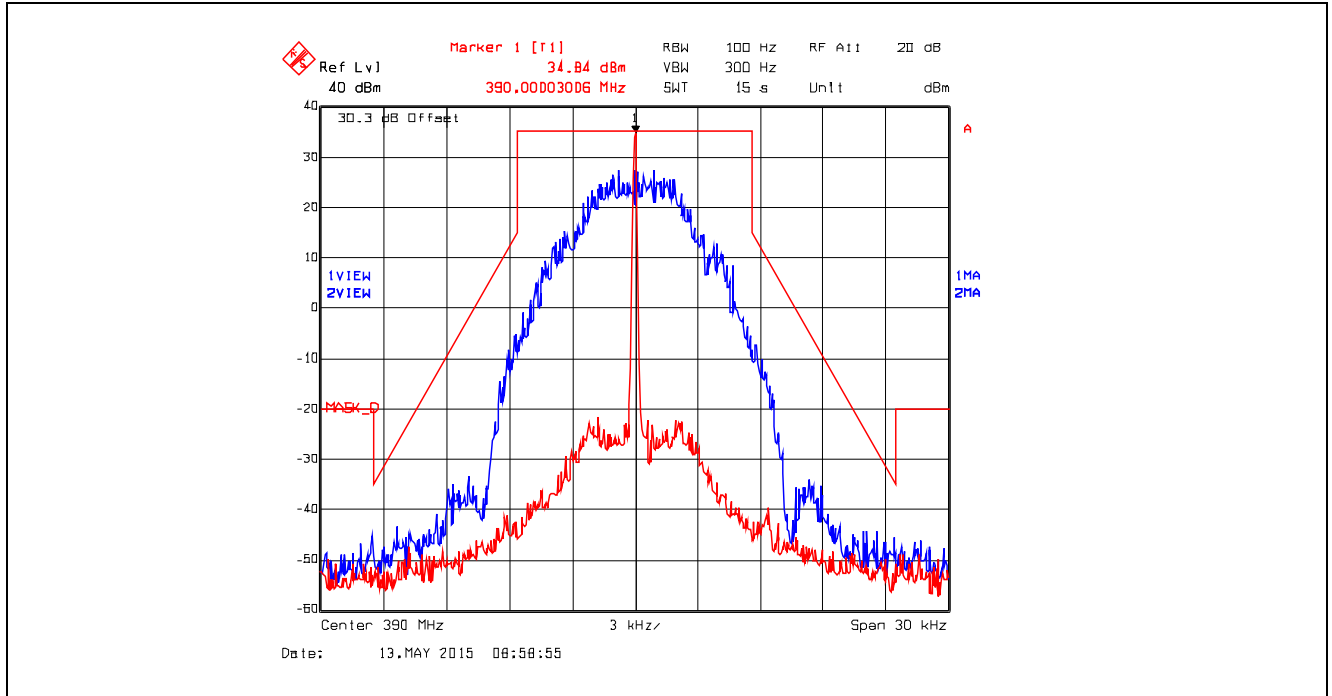

Plot 5.4.4.5.4. Emission Mask D, Digital at 9.6 kbps, 390.0 MHz, Low Power

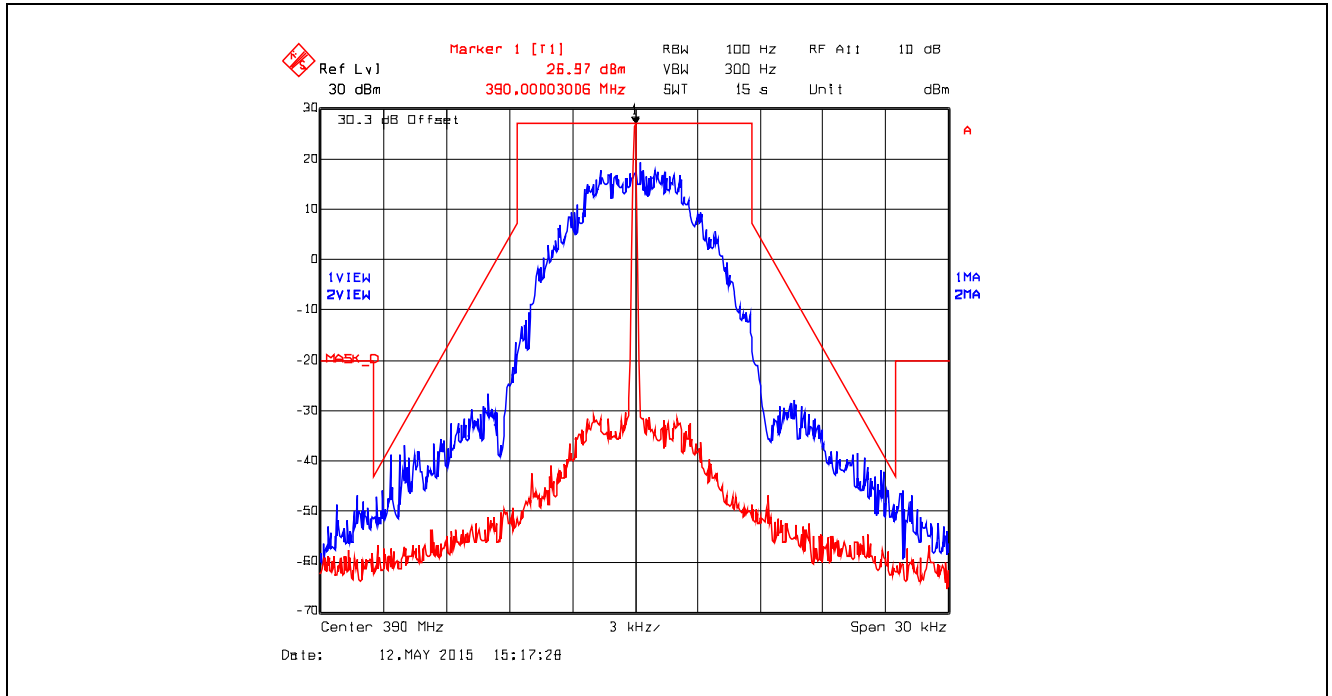

Plot 5.4.4.5.5. Emission Mask D, Digital at 9.6 kbps, 399.9 MHz, High Power

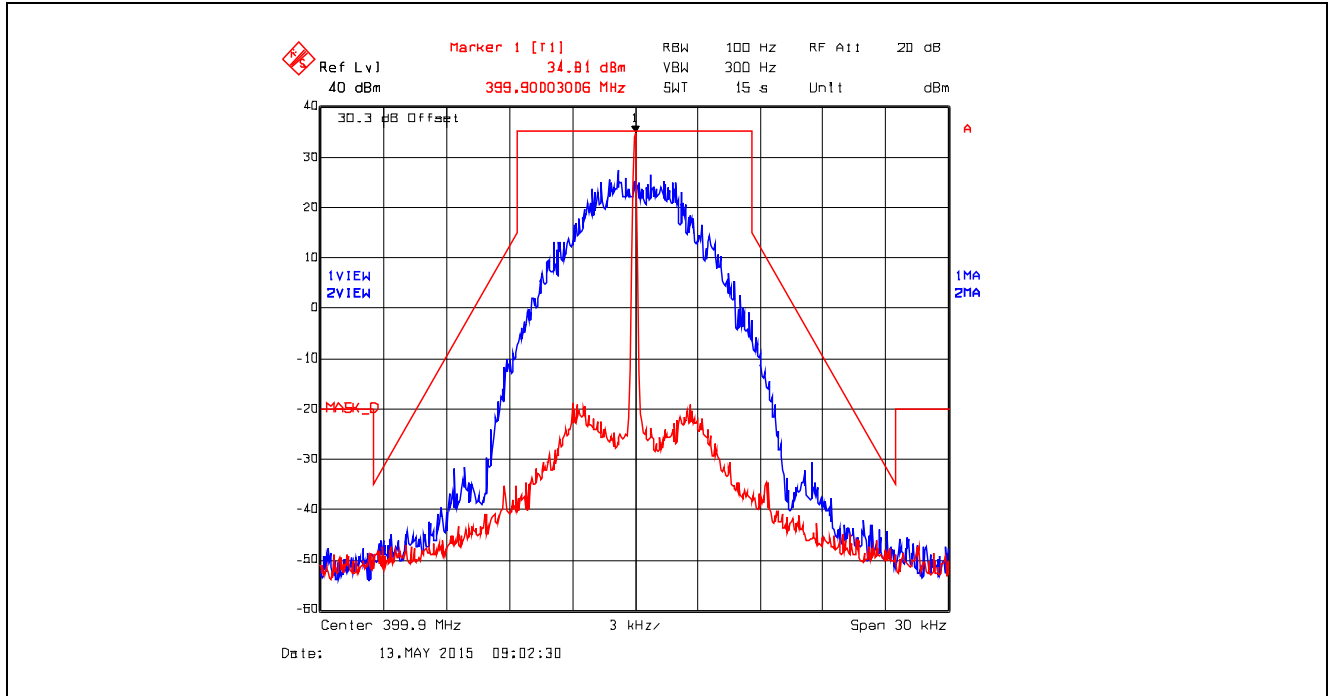

Plot 5.4.4.5.6. Emission Mask D, Digital at 9.6 kbps, 399.9 MHz, Low Power

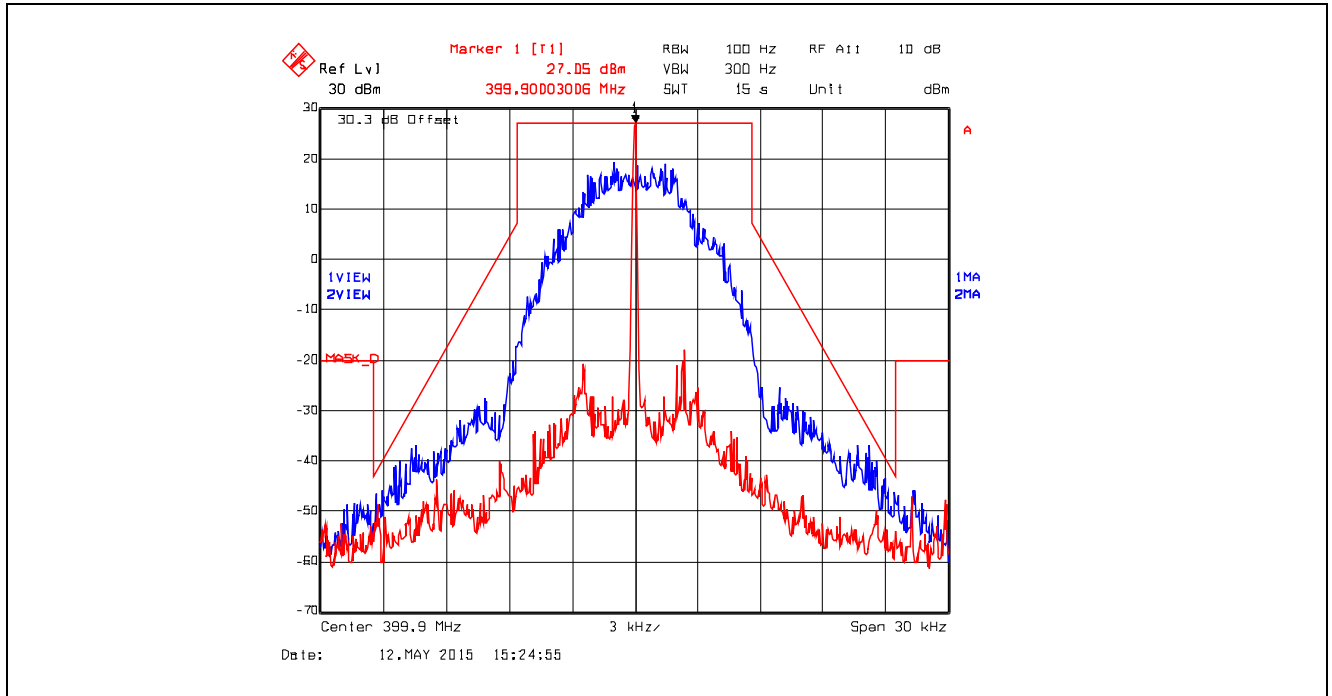

Plot 5.4.4.5.7. Emission Mask D, Digital at 9.6 kbps, 406.2 MHz, High Power

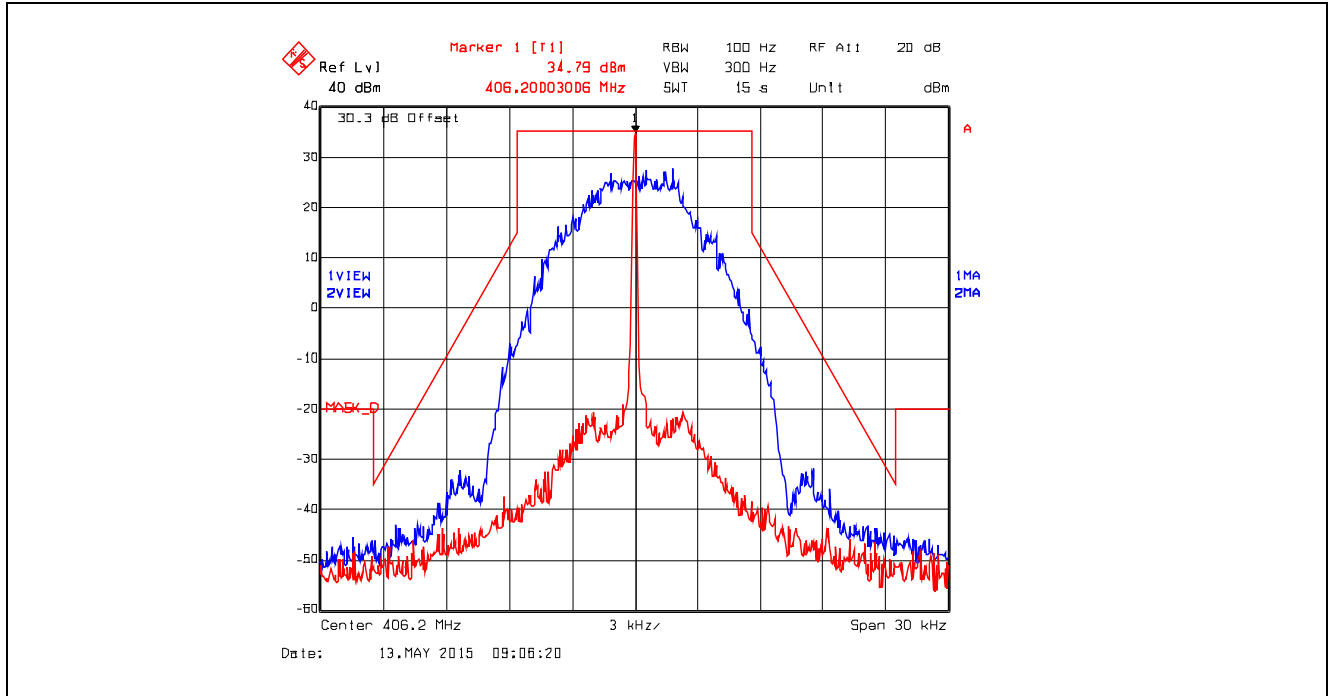

Plot 5.4.4.5.8. Emission Mask D, Digital at 9.6 kbps, 406.2 MHz, Low Power

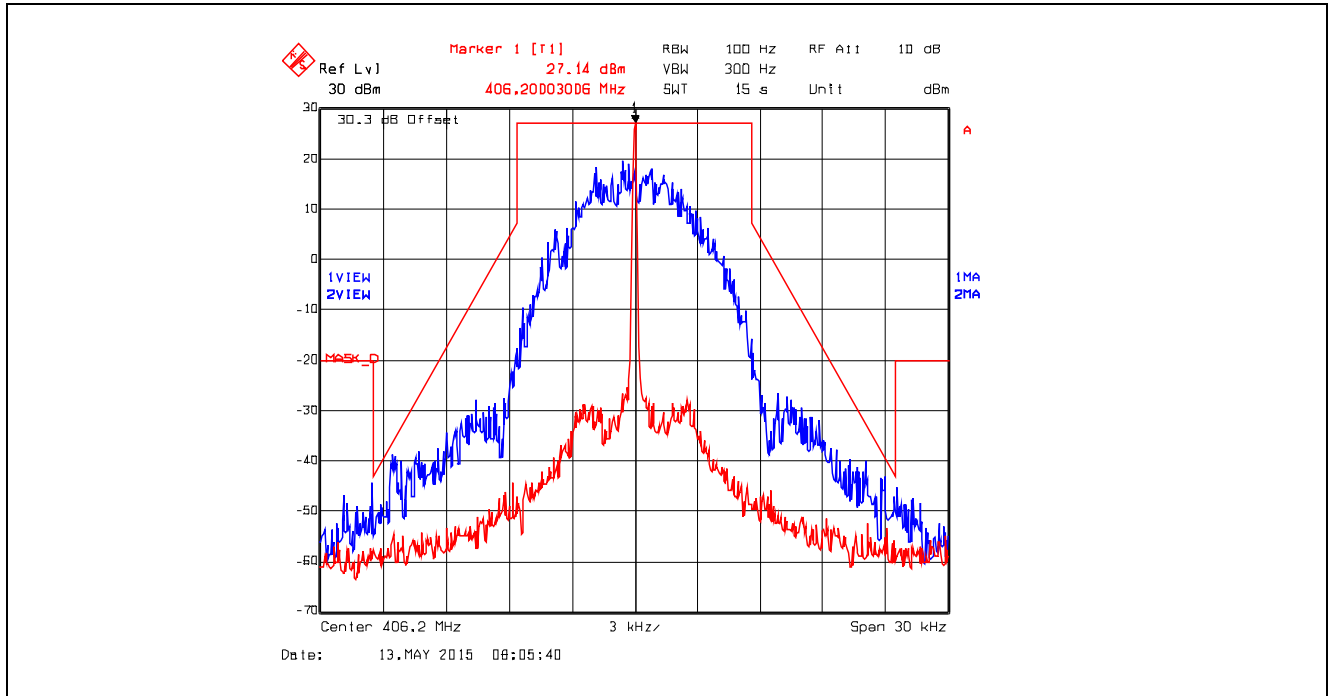

Plot 5.4.4.5.9. Emission Mask D, Digital at 9.6 kbps, 415.0 MHz, High Power

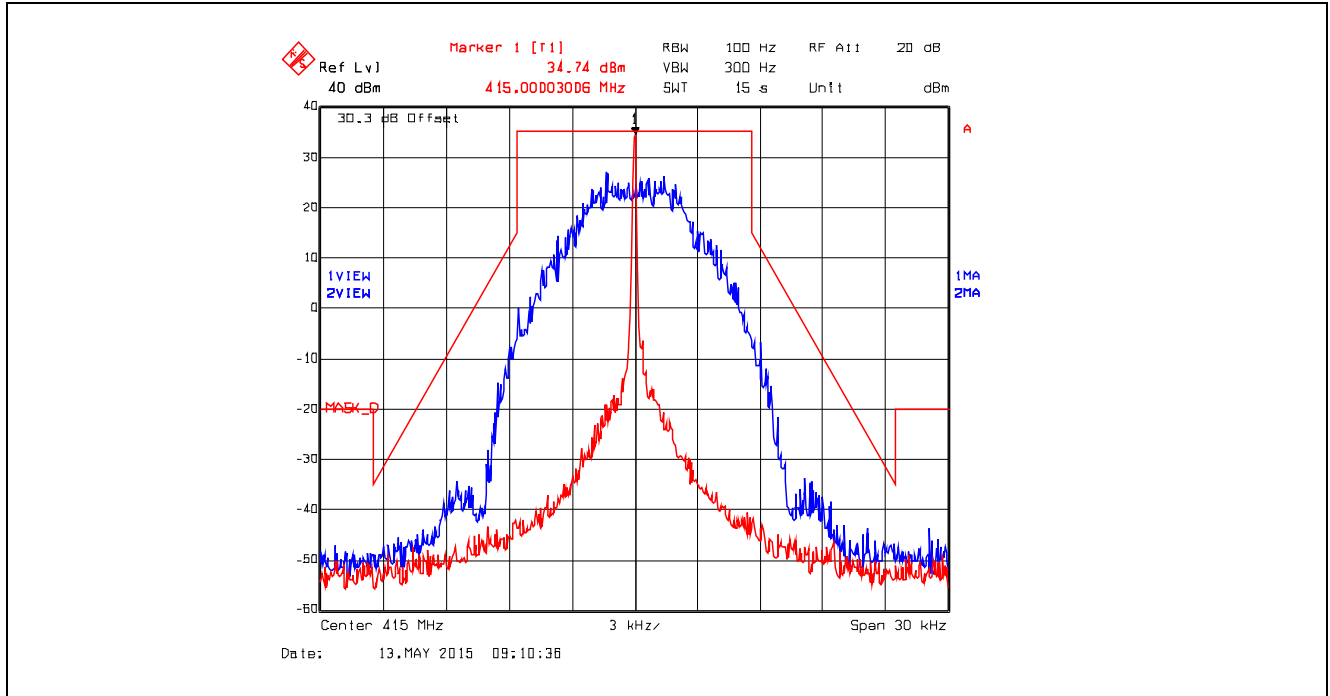

Plot 5.4.4.5.10. Emission Mask D, Digital at 9.6 kbps, 415.0 MHz, Low Power

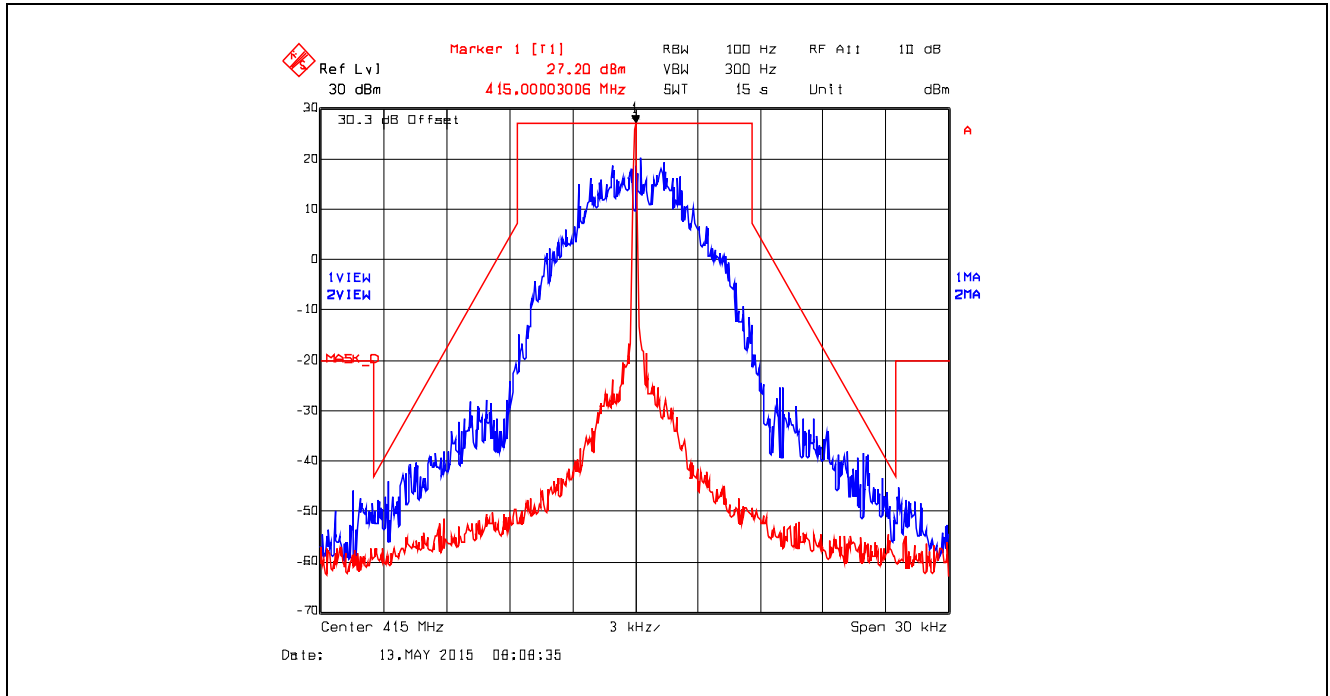

Plot 5.4.4.5.11. Emission Mask D, Digital at 9.6 kbps, 429.9 MHz, High Power

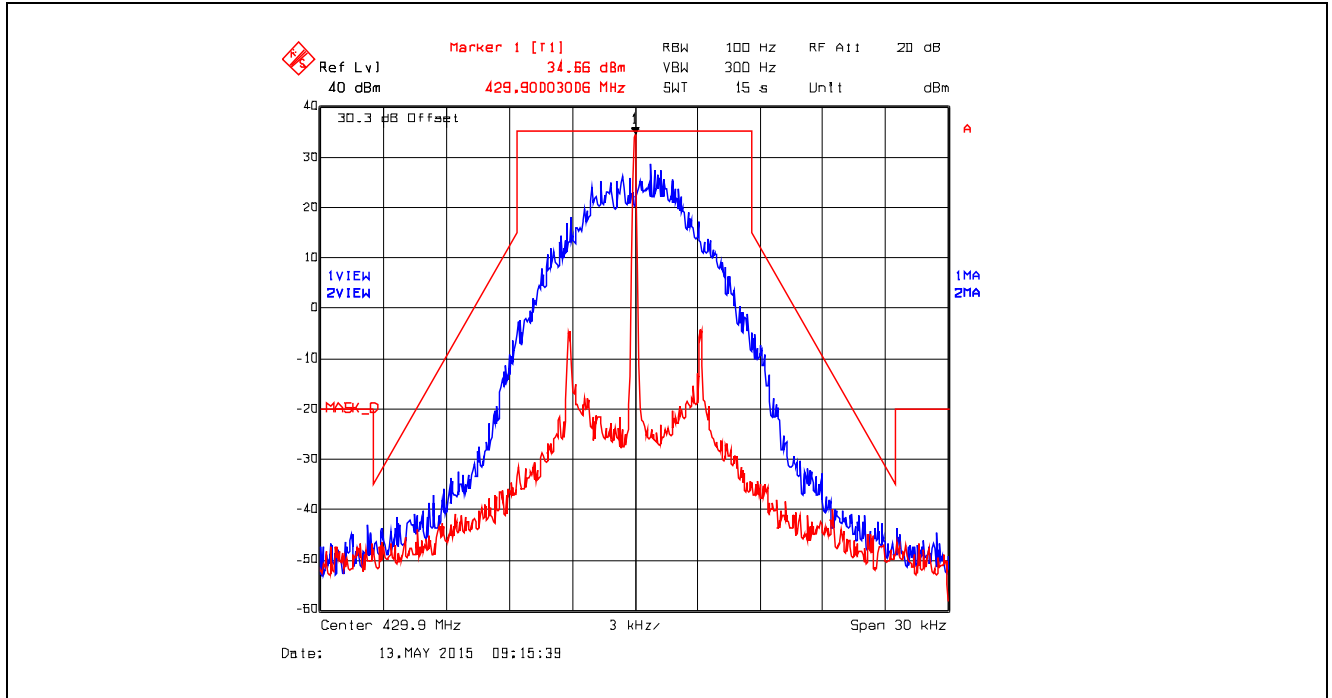

Plot 5.4.4.5.12. Emission Mask D, Digital at 9.6 kbps, 429.9 MHz, Low Power

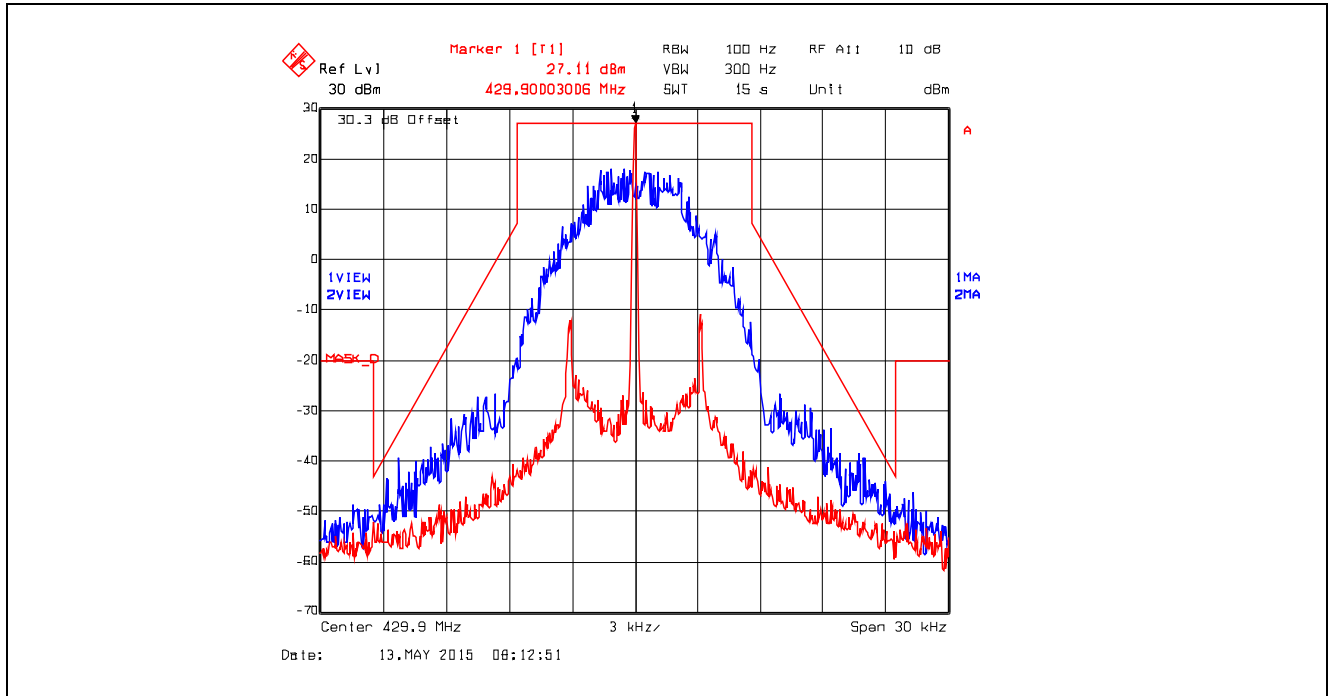

Plot 5.4.4.5.13. Emission Mask D, Digital at 9.6 kbps, 450.1 MHz, High Power

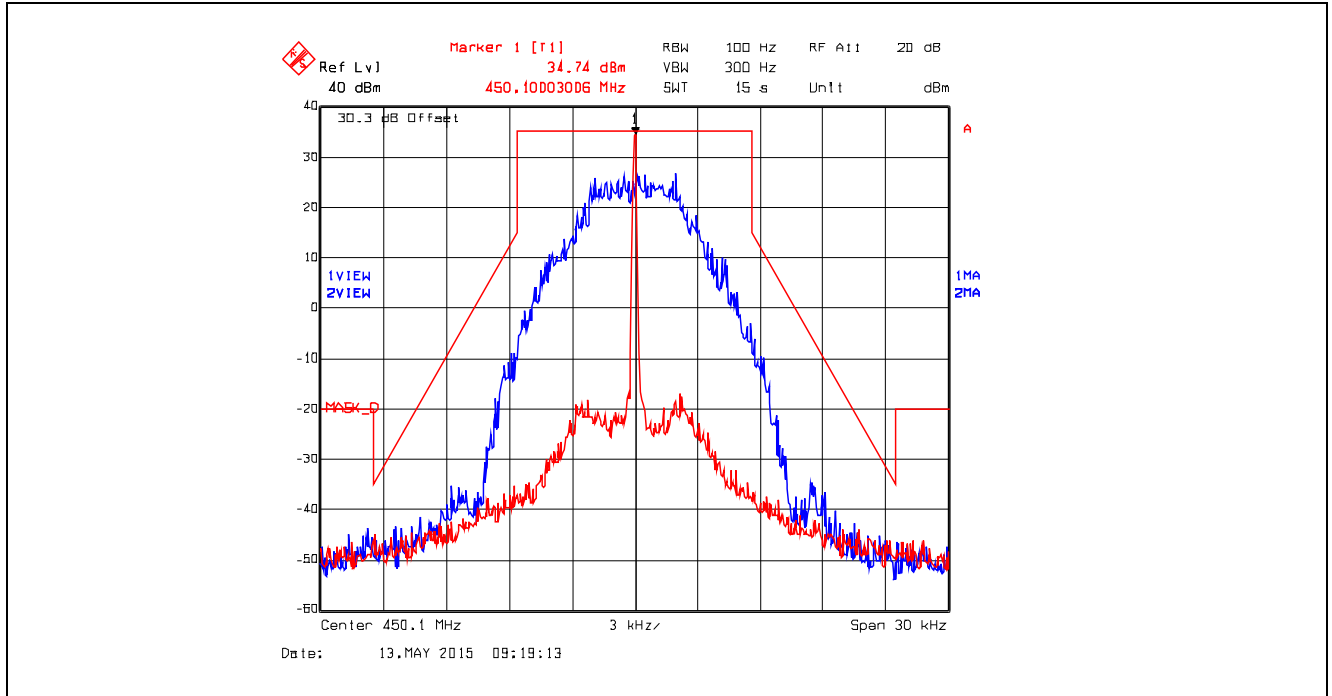

Plot 5.4.4.5.14. Emission Mask D, Digital at 9.6 kbps, 450.1 MHz, Low Power

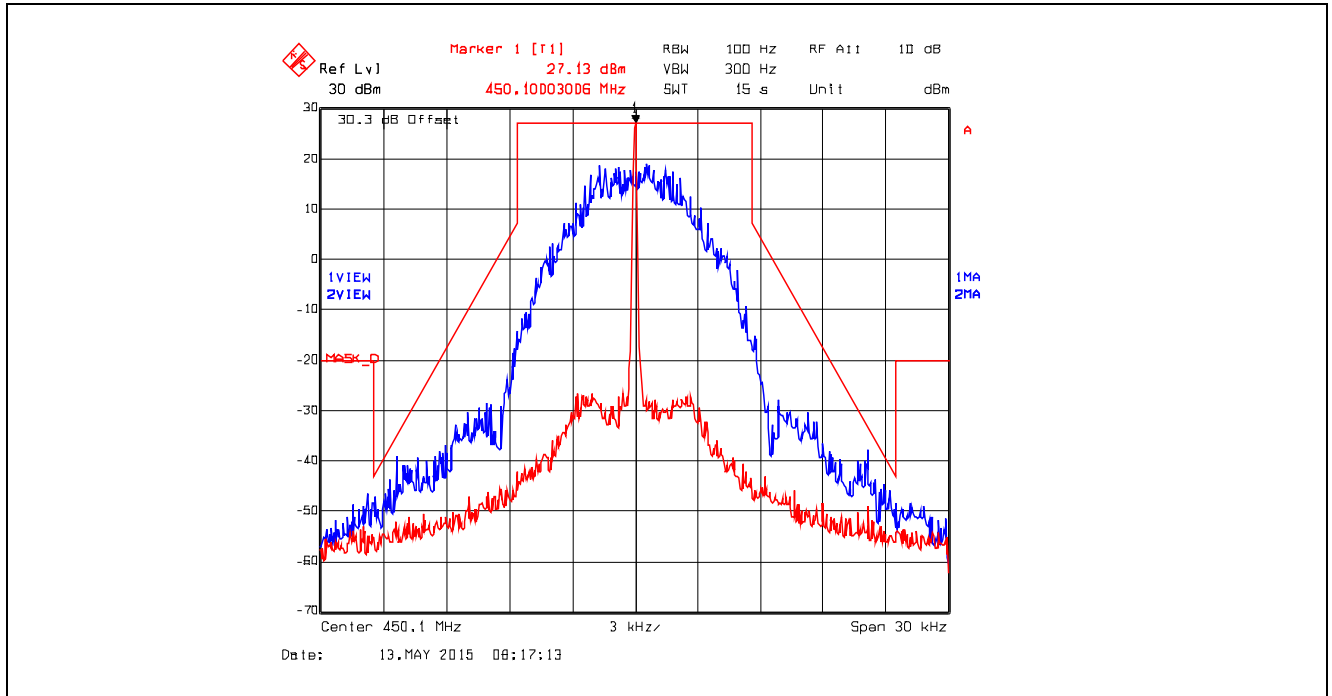

Plot 5.4.4.5.15. Emission Mask D, Digital at 9.6 kbps, 470.0 MHz, High Power

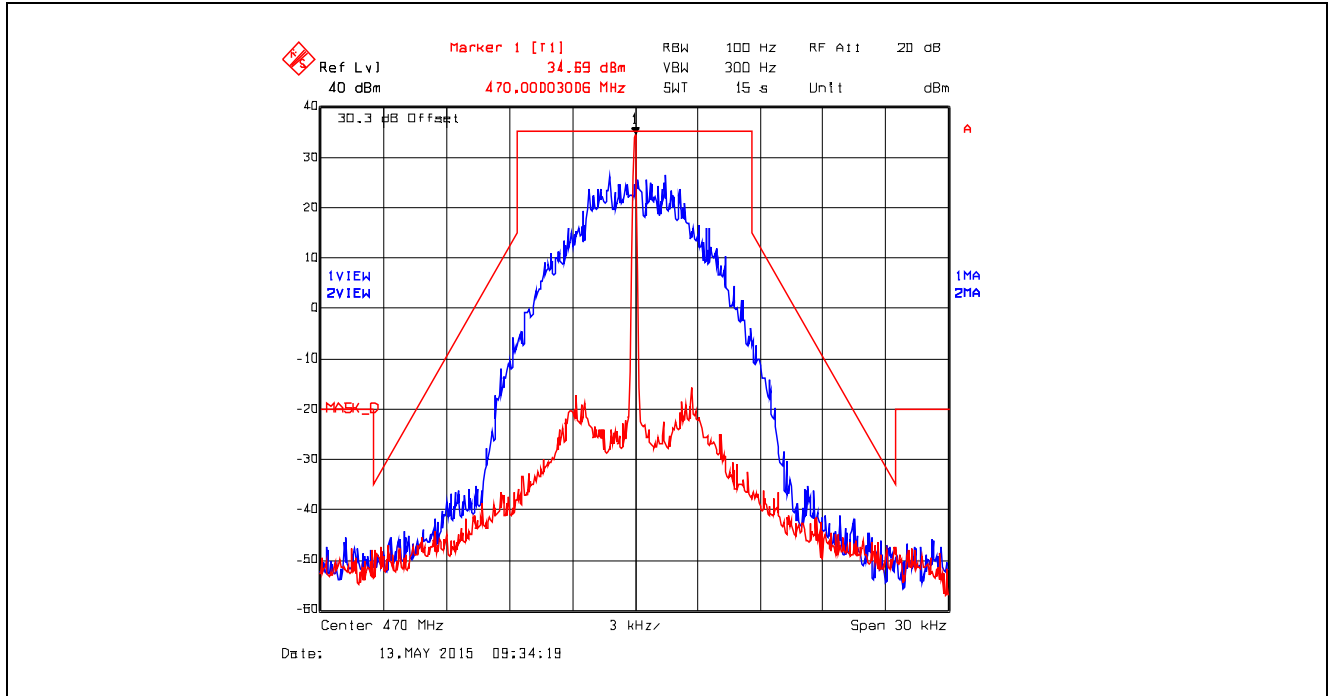

Plot 5.4.4.5.16. Emission Mask D, Digital at 9.6 kbps, 470.0 MHz, Low Power

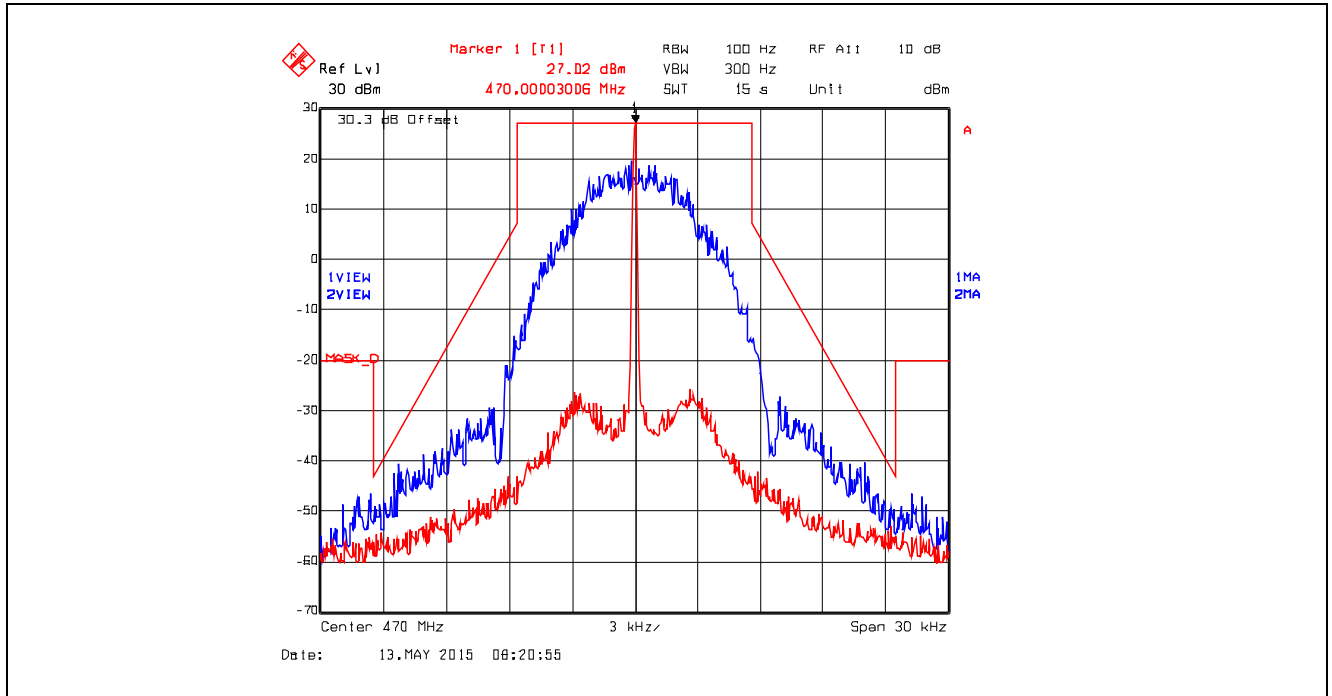

ULTRATECH GROUP OF LABS

3000 Bristol Circle, Oakville, Ontario, Canada L6H 6G4
Tel. #: 905-829-1570, Fax. #: 905-829-8050, Email: vic@ultratech-labs.com, Website: <http://www.ultratech-labs.com>

File #: 15FSG141_FCC90
July 8, 2015

All test results contained in this engineering test report are traceable to National Institute of Standards and Technology (NIST)

Plot 5.4.4.5.17. Emission Mask D, Digital at 9.6 kbps, 511.9 MHz, High Power

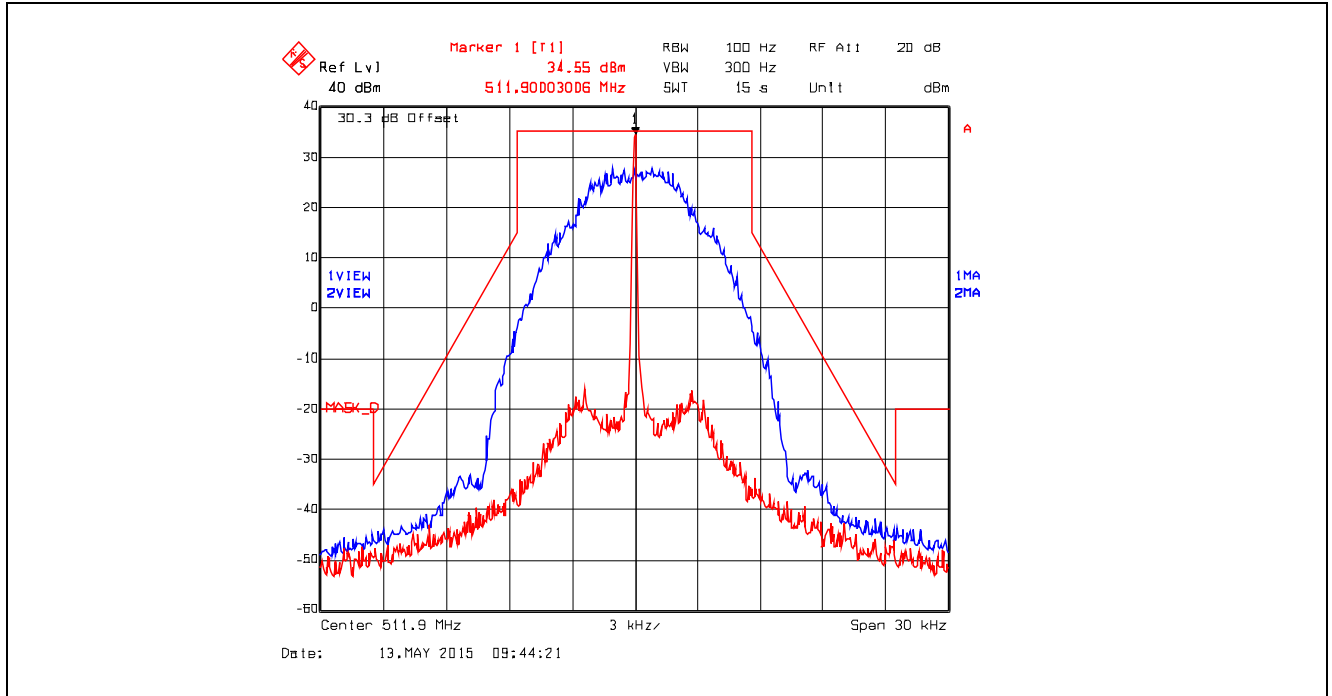

Plot 5.4.4.5.18. Emission Mask D, Digital at 9.6 kbps, 511.9 MHz, Low Power

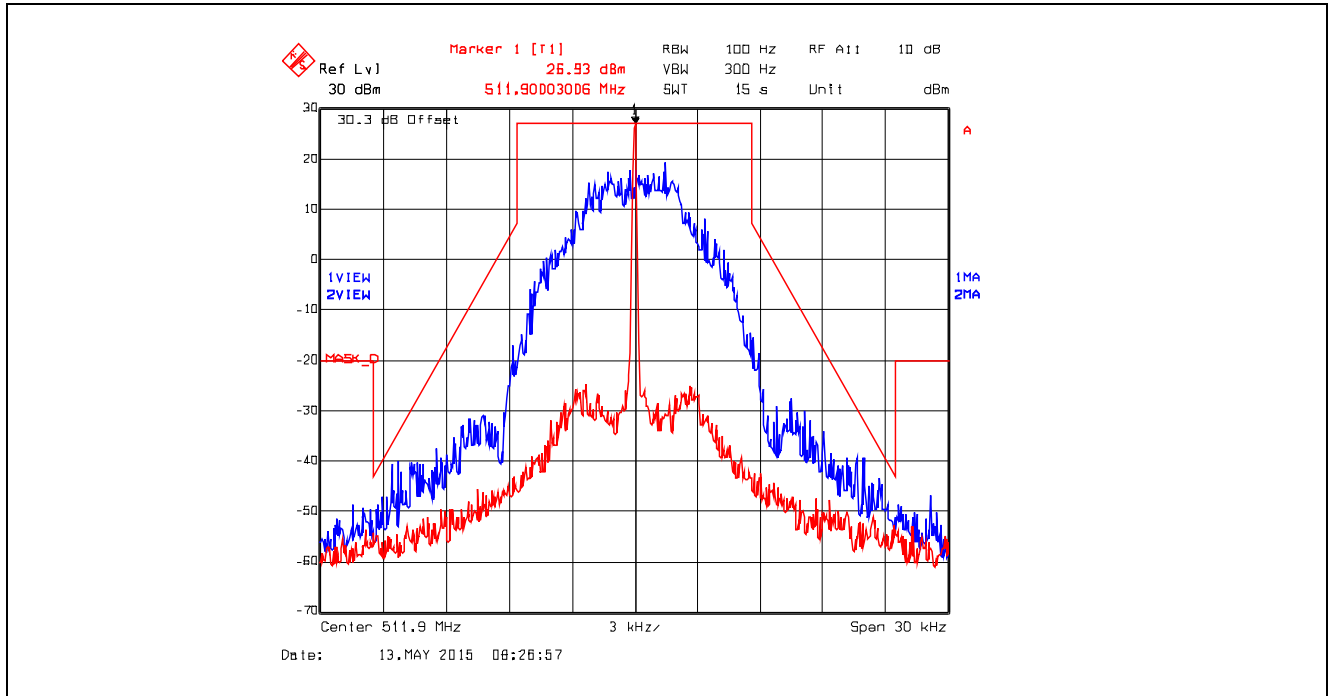

5.4.4.6. Emission Mask E, Digital at 4.8 kbps

Plot 5.4.4.6.1. Emission Mask E, Digital at 4.8 kbps, 381.1 MHz, High Power

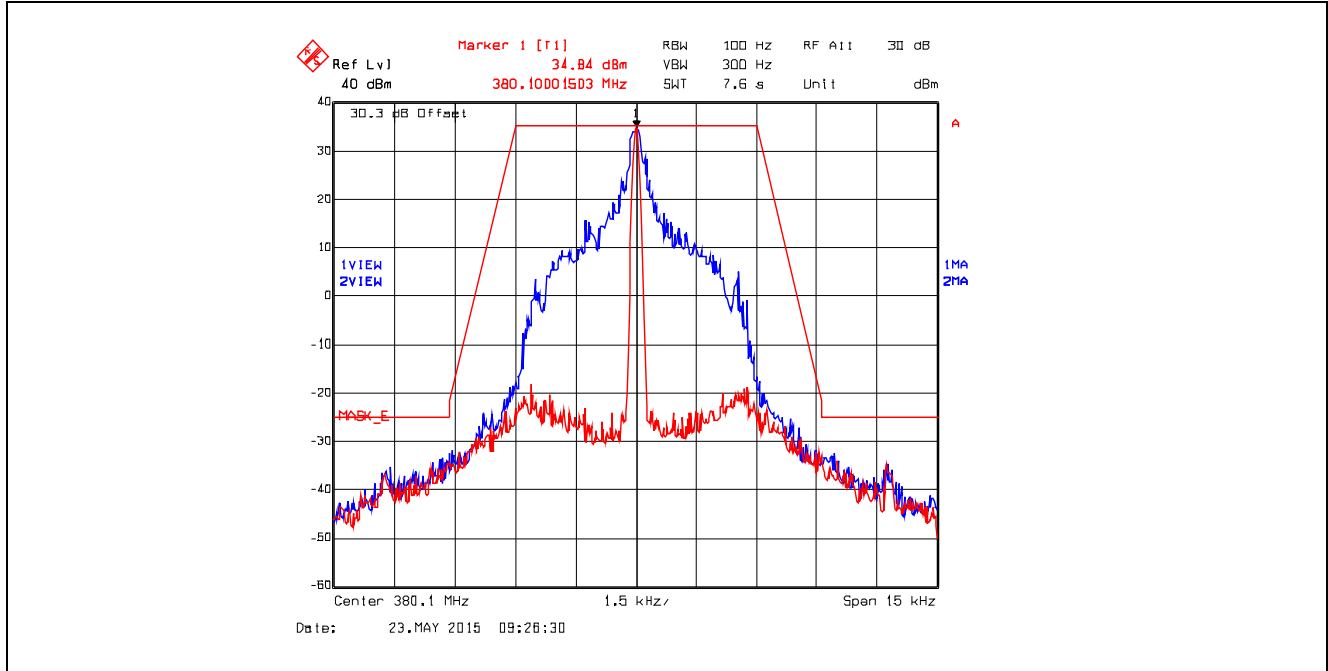

Plot 5.4.4.6.2. Emission Mask E, Digital at 4.8 kbps, 381.1 MHz, Low Power

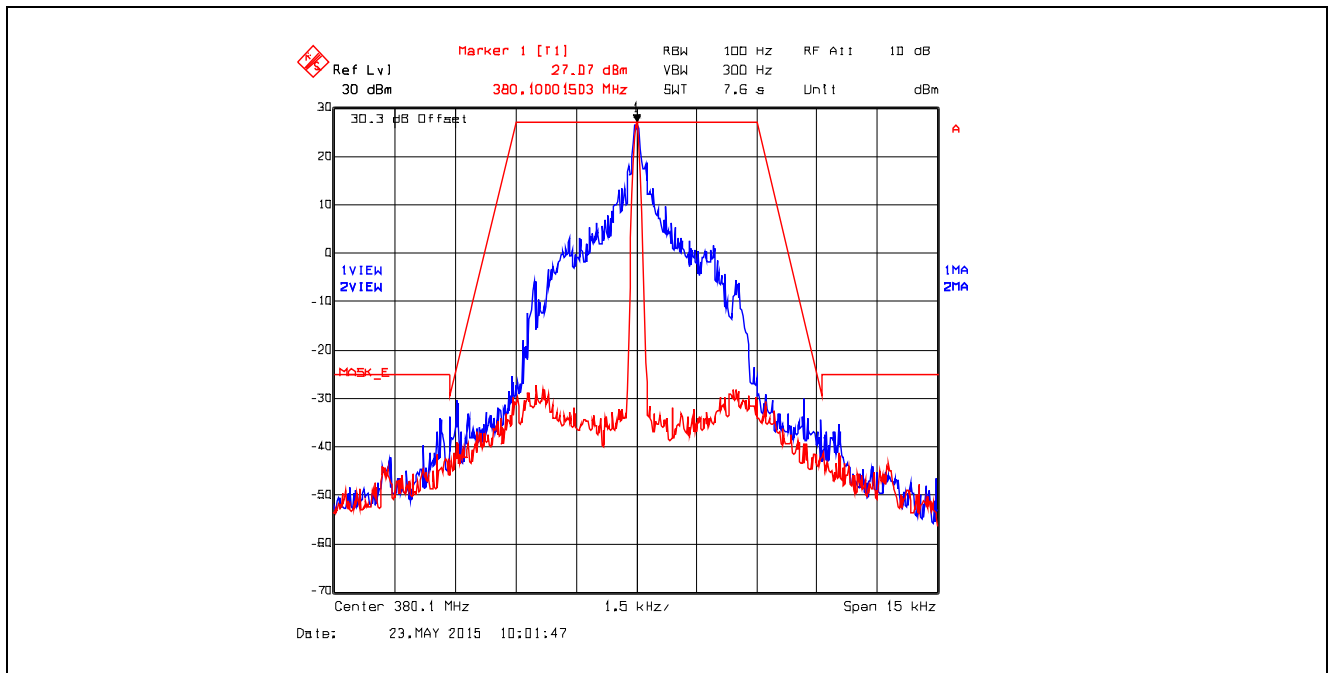

Plot 5.4.4.6.3. Emission Mask E, Digital at 4.8 kbps, 390.0 MHz, High Power

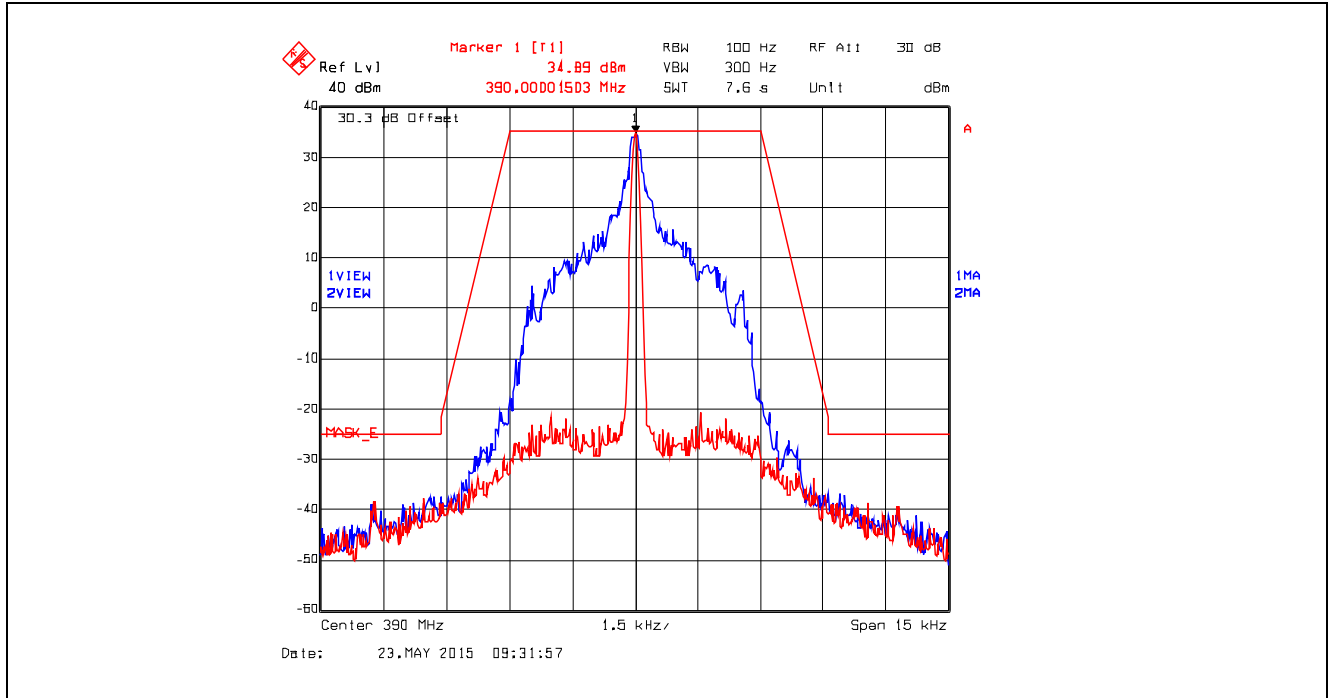

Plot 5.4.4.6.4. Emission Mask E, Digital at 4.8 kbps, 390.0 MHz, Low Power

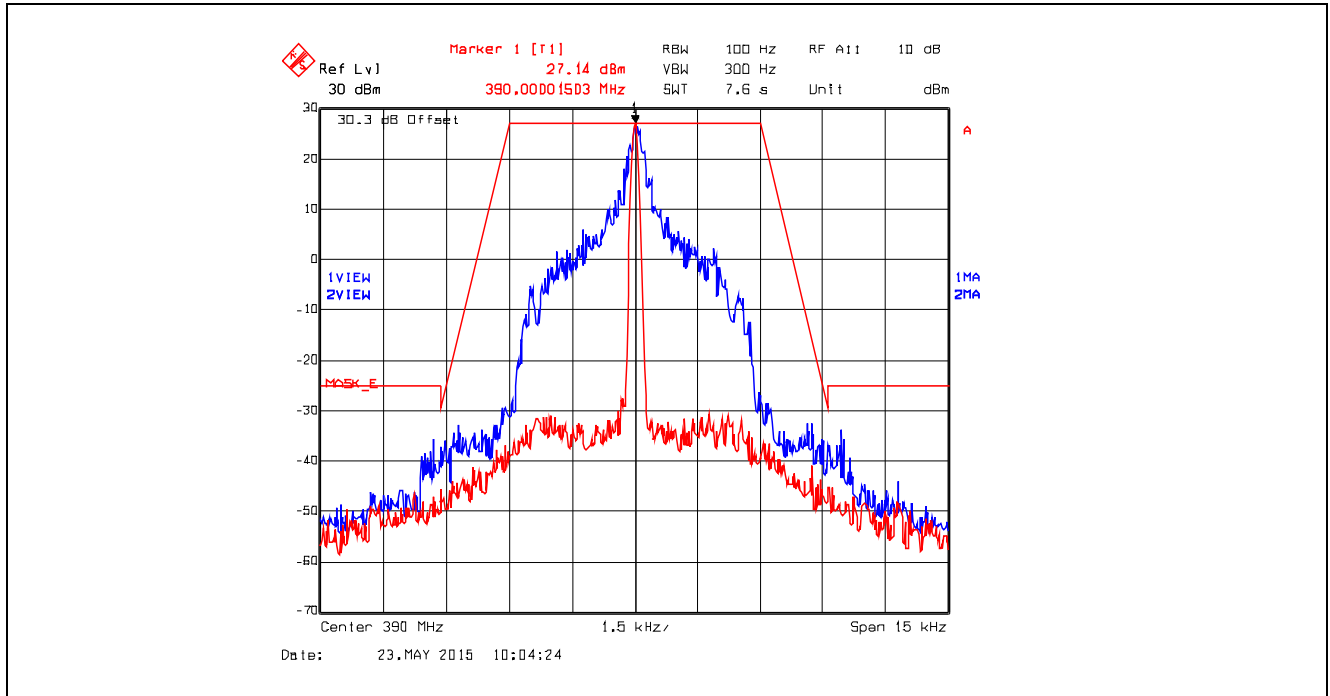

Plot 5.4.4.6.5. Emission Mask E, Digital at 4.8 kbps, 399.9 MHz, High Power

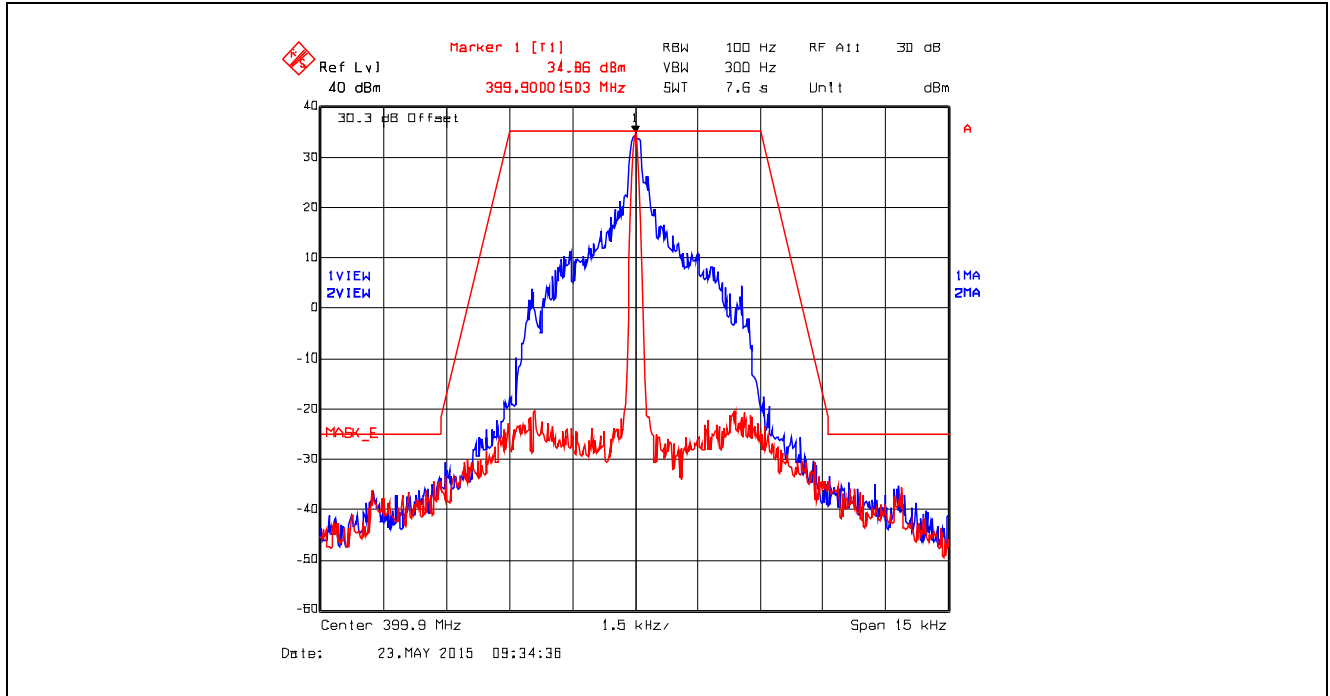

Plot 5.4.4.6.6. Emission Mask E, Digital at 4.8 kbps, 399.9 MHz, Low Power

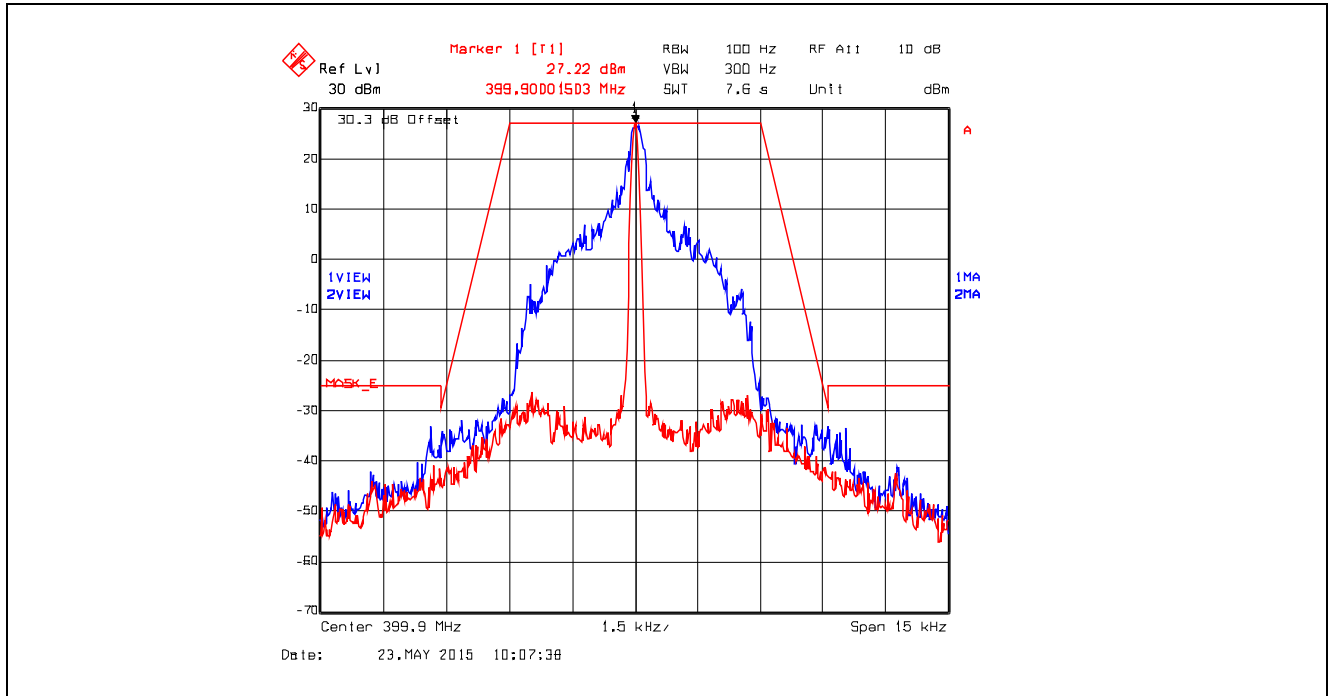

Plot 5.4.4.6.7. Emission Mask E, Digital at 4.8 kbps, 406.2 MHz, High Power

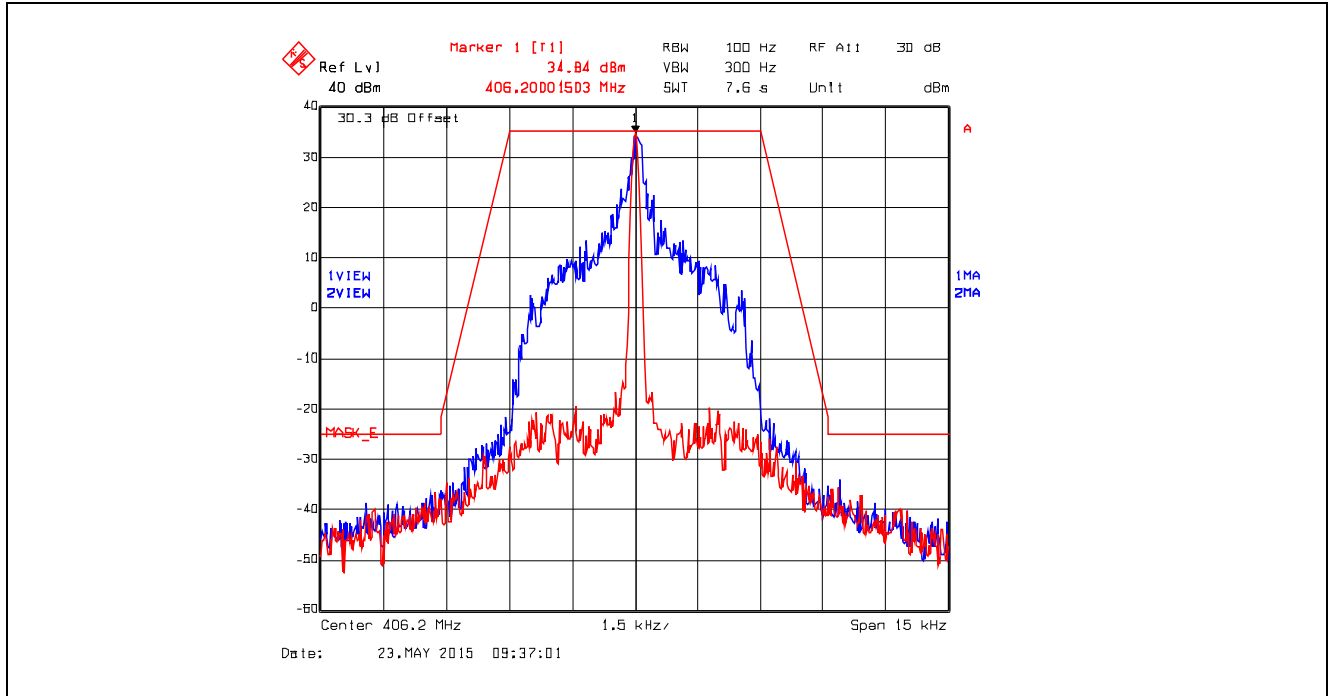

Plot 5.4.4.6.8. Emission Mask E, Digital at 4.8 kbps, 406.2 MHz, Low Power

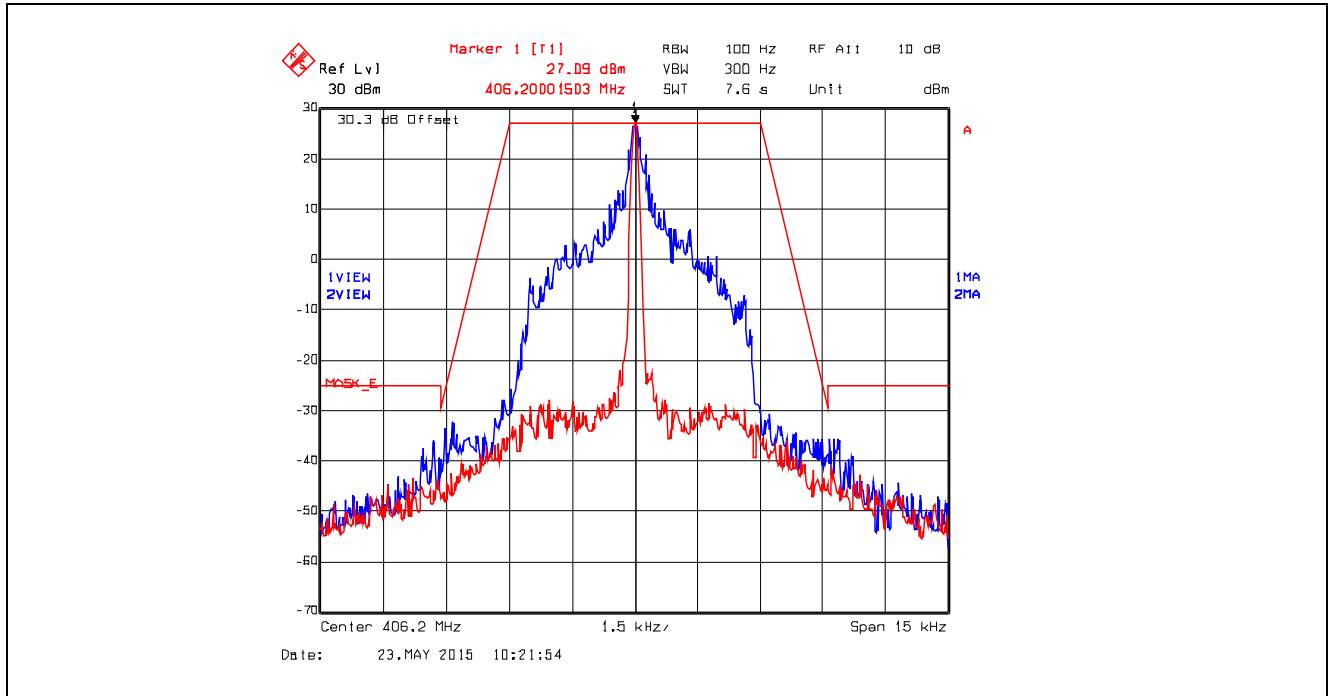

Plot 5.4.4.6.9. Emission Mask E, Digital at 4.8 kbps, 415.0 MHz, High Power

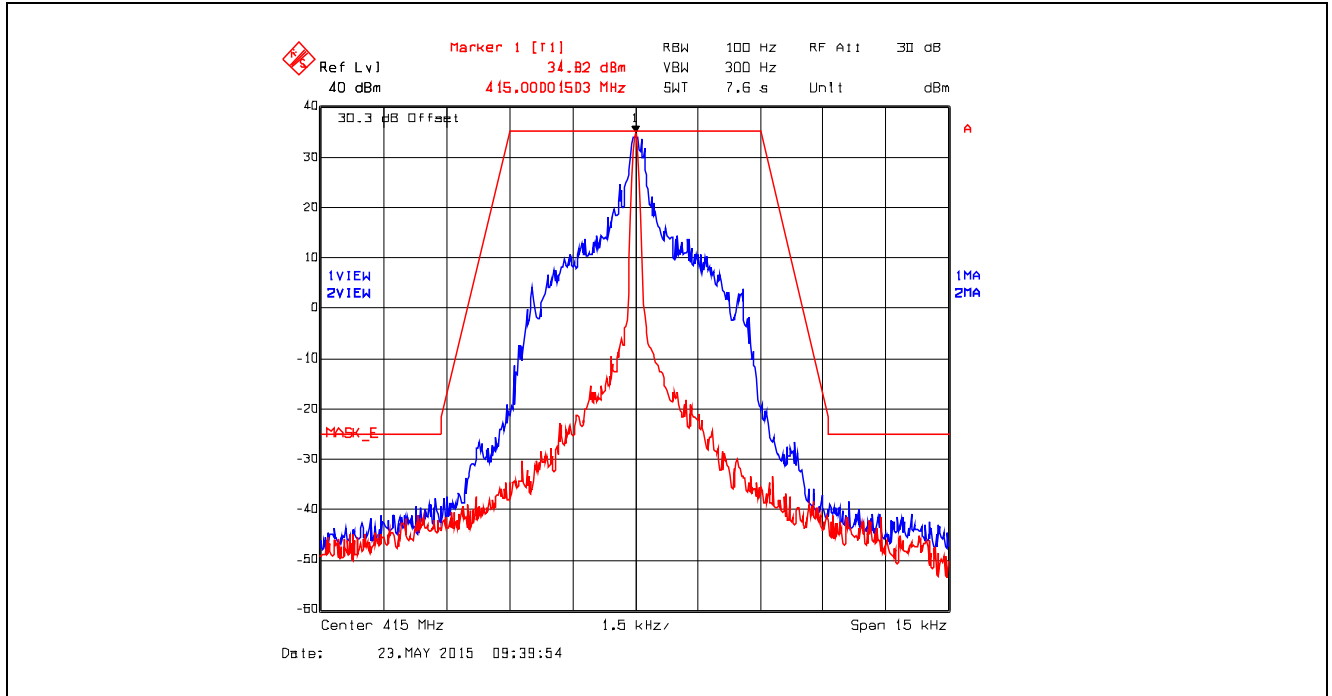

Plot 5.4.4.6.10. Emission Mask E, Digital at 4.8 kbps, 415.0 MHz, Low Power

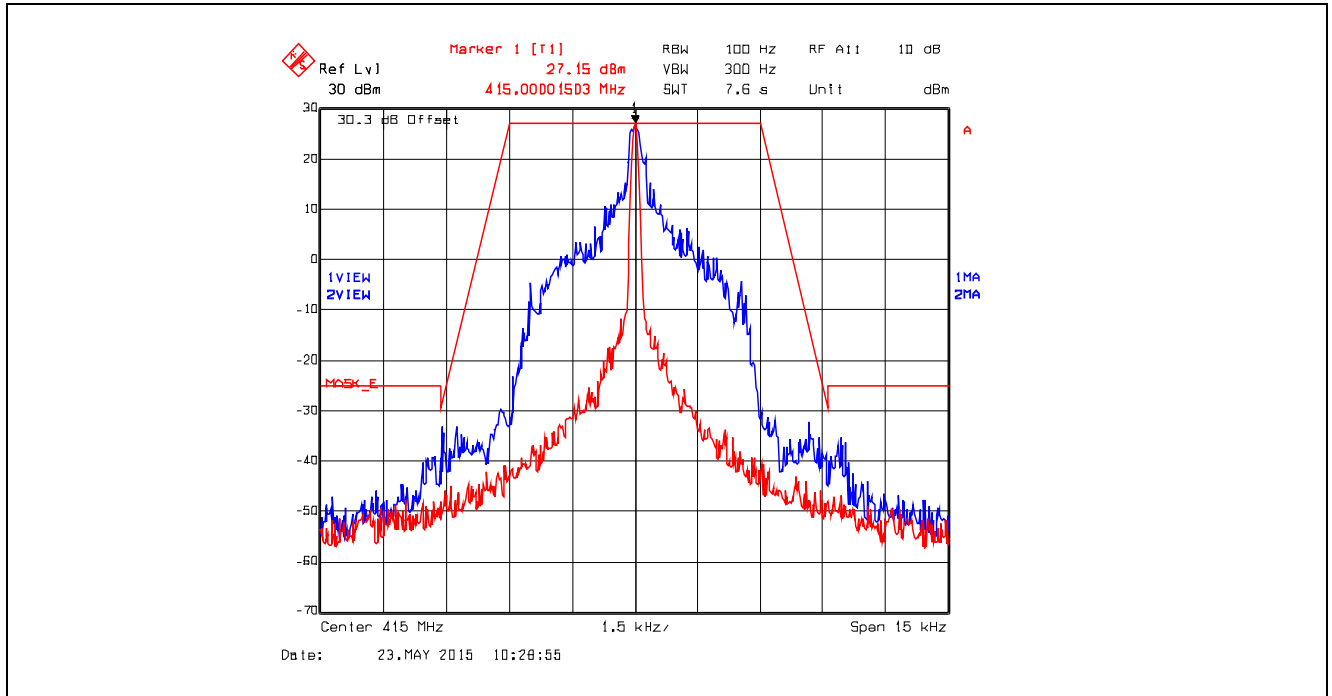

Plot 5.4.4.6.11. Emission Mask E, Digital at 4.8 kbps, 429.9 MHz, High Power

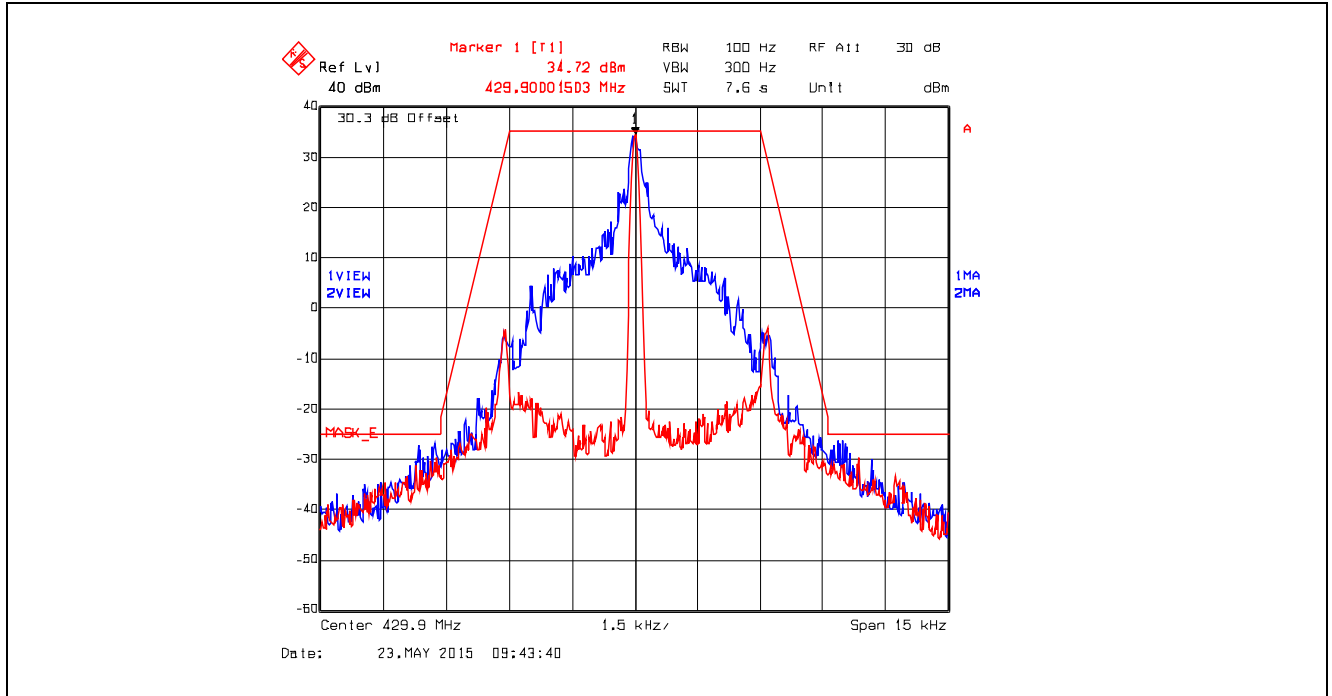

Plot 5.4.4.6.12. Emission Mask E, Digital at 4.8 kbps, 429.9 MHz, Low Power

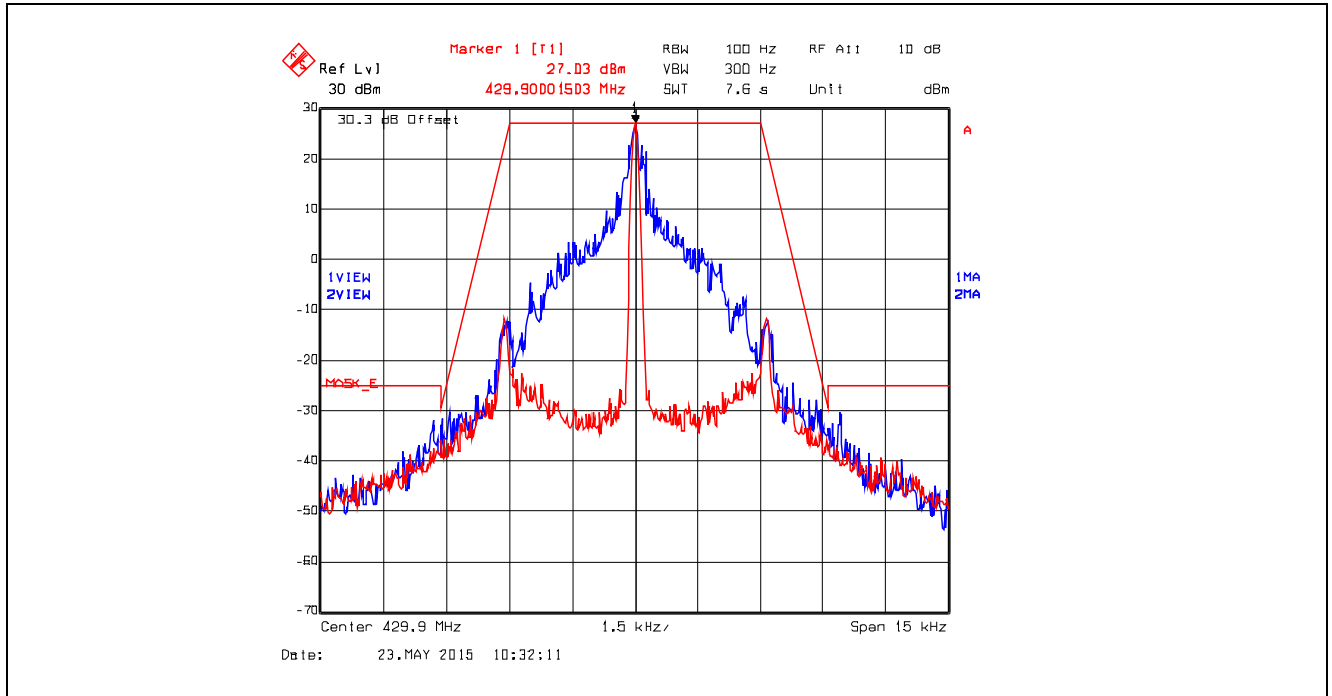

Plot 5.4.4.6.13. Emission Mask E, Digital at 4.8 kbps, 450.1 MHz, High Power

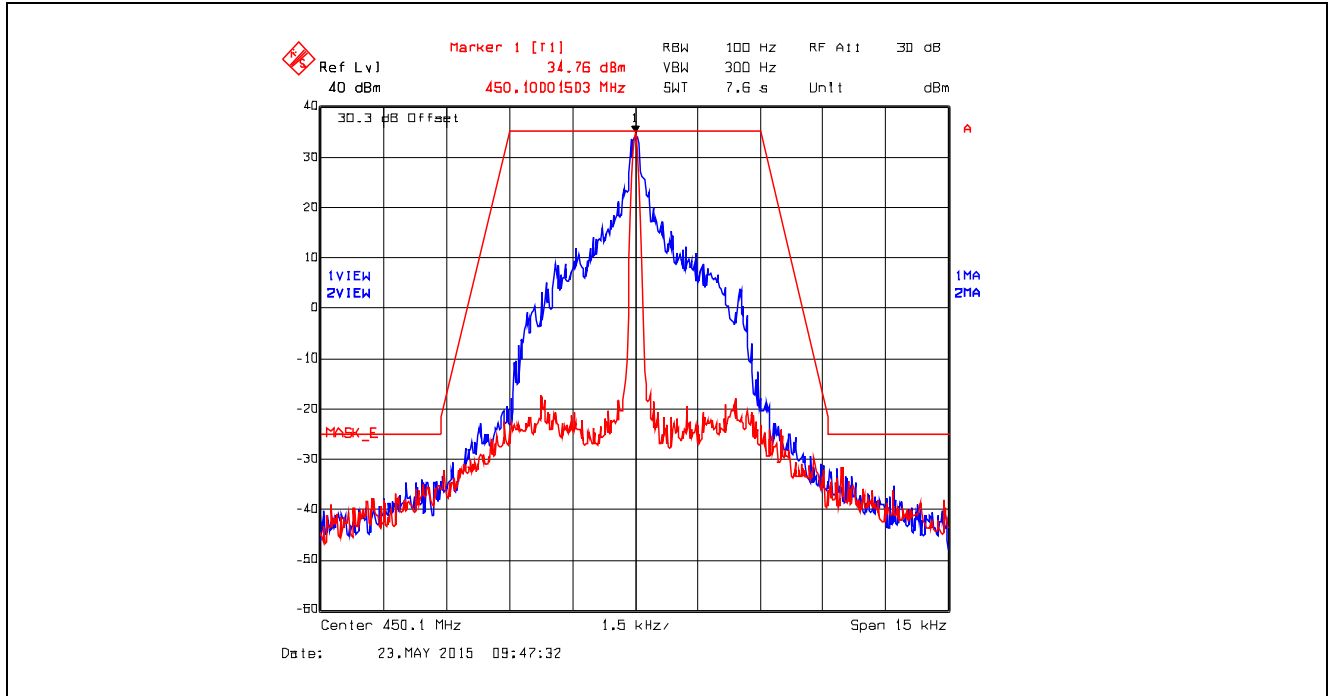

Plot 5.4.4.6.14. Emission Mask E, Digital at 4.8 kbps, 450.1 MHz, Low Power

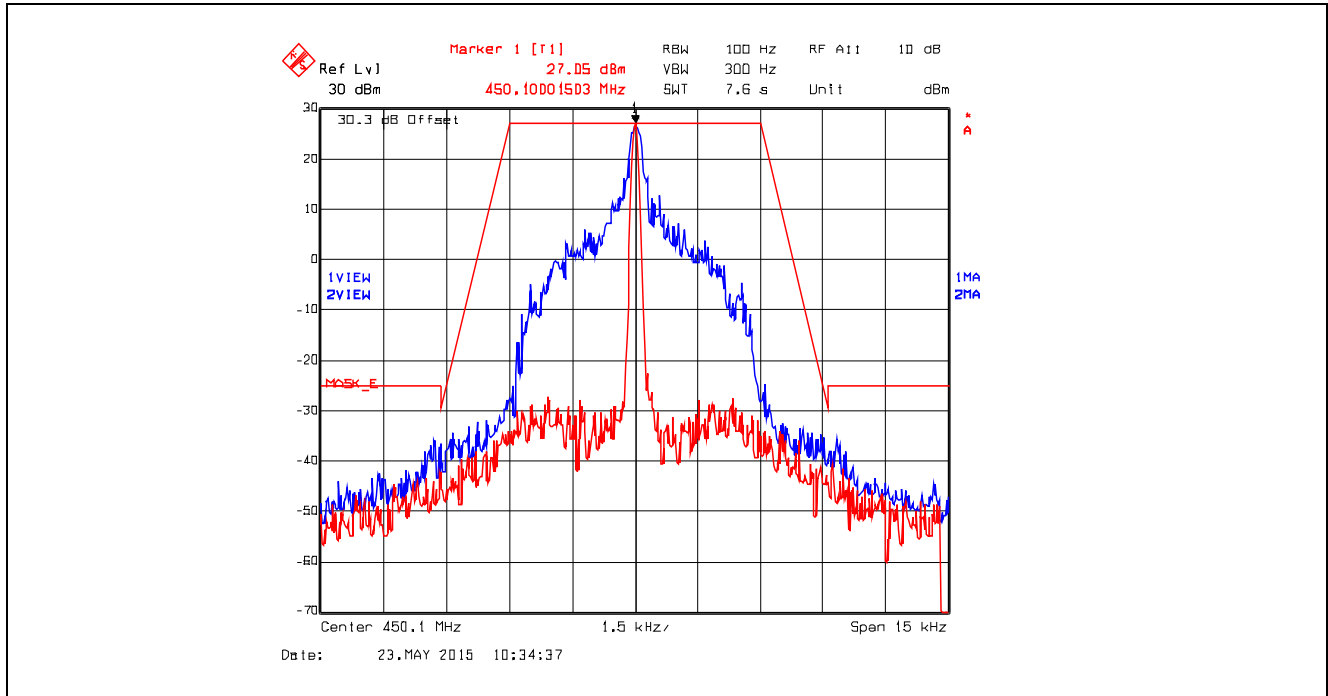

Plot 5.4.4.6.15. Emission Mask E, Digital at 4.8 kbps, 470.0 MHz, High Power

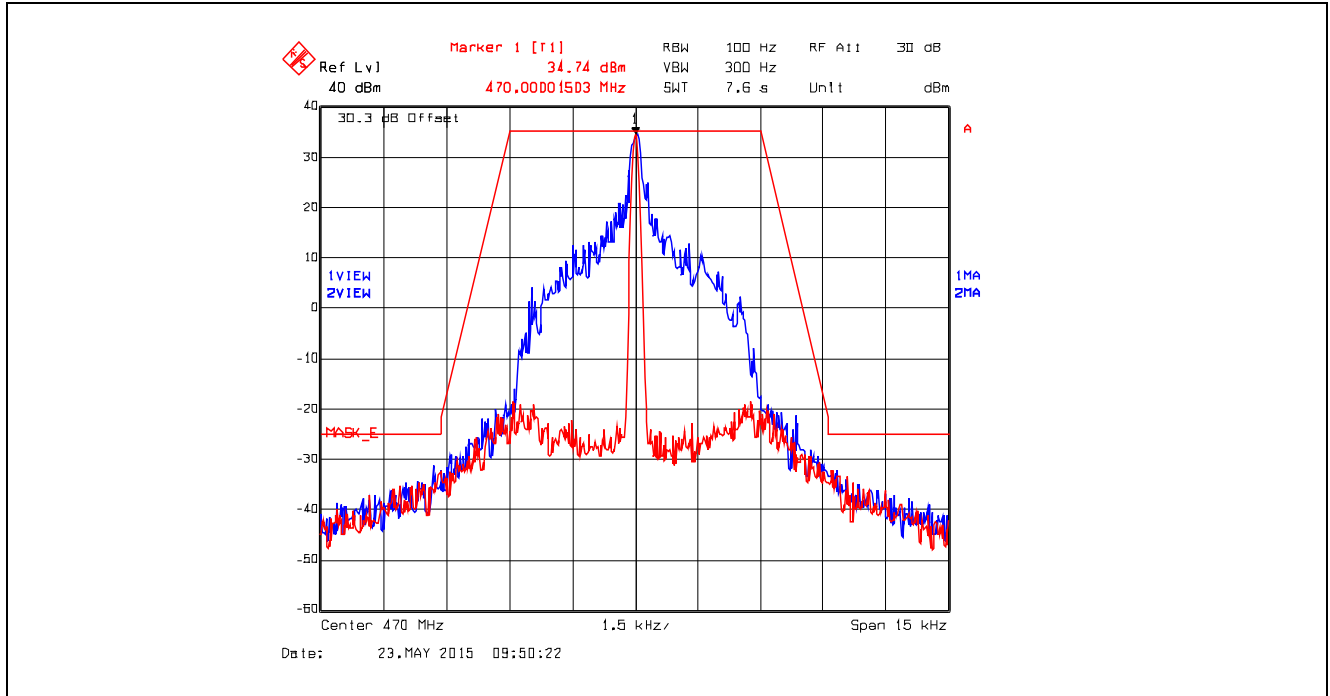

Plot 5.4.4.6.16. Emission Mask E, Digital at 4.8 kbps, 470.0 MHz, Low Power

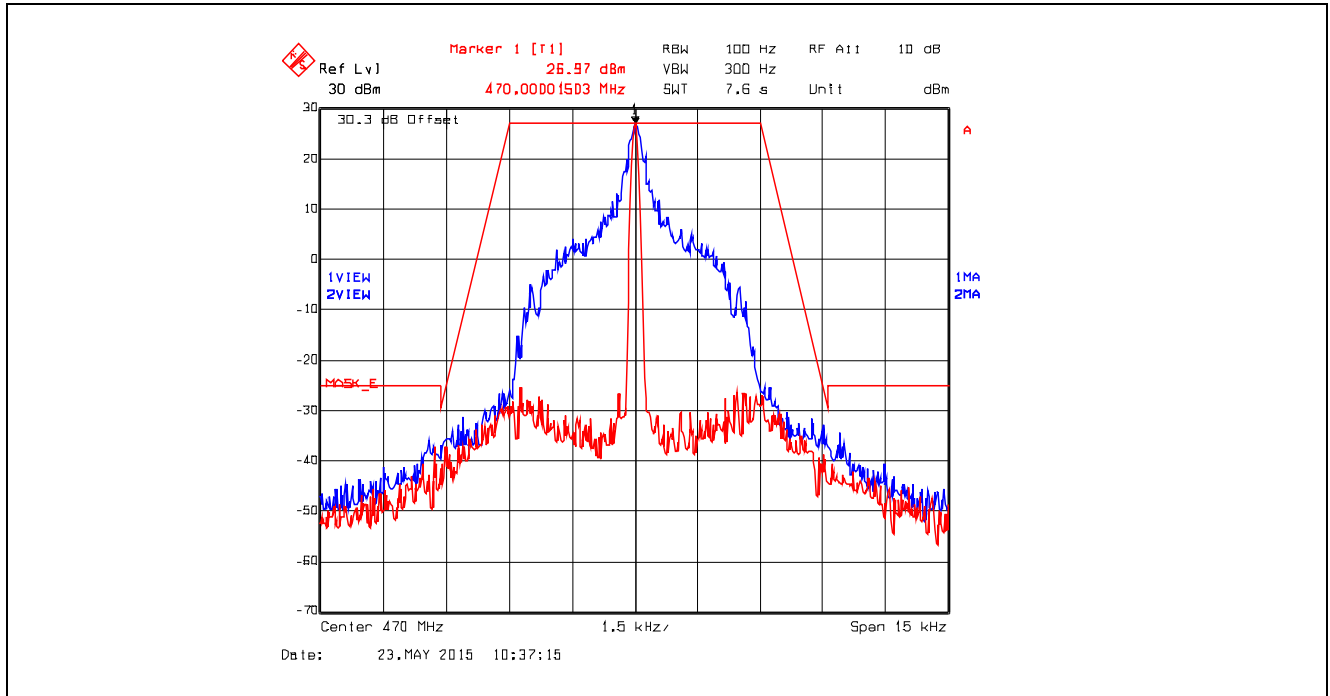

Plot 5.4.4.6.17. Emission Mask E, Digital at 4.8 kbps, 511.9 MHz, High Power

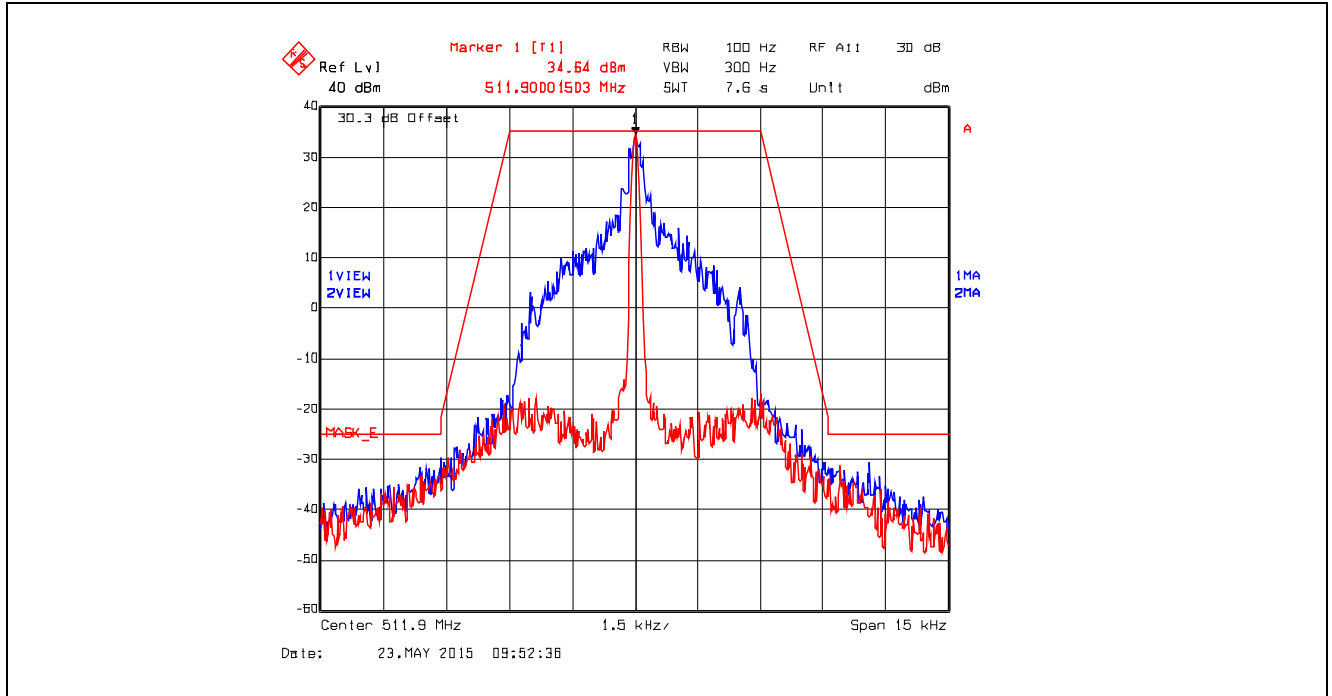

Plot 5.4.4.6.18. Emission Mask E, Digital at 4.8 kbps, 511.9 MHz, Low Power

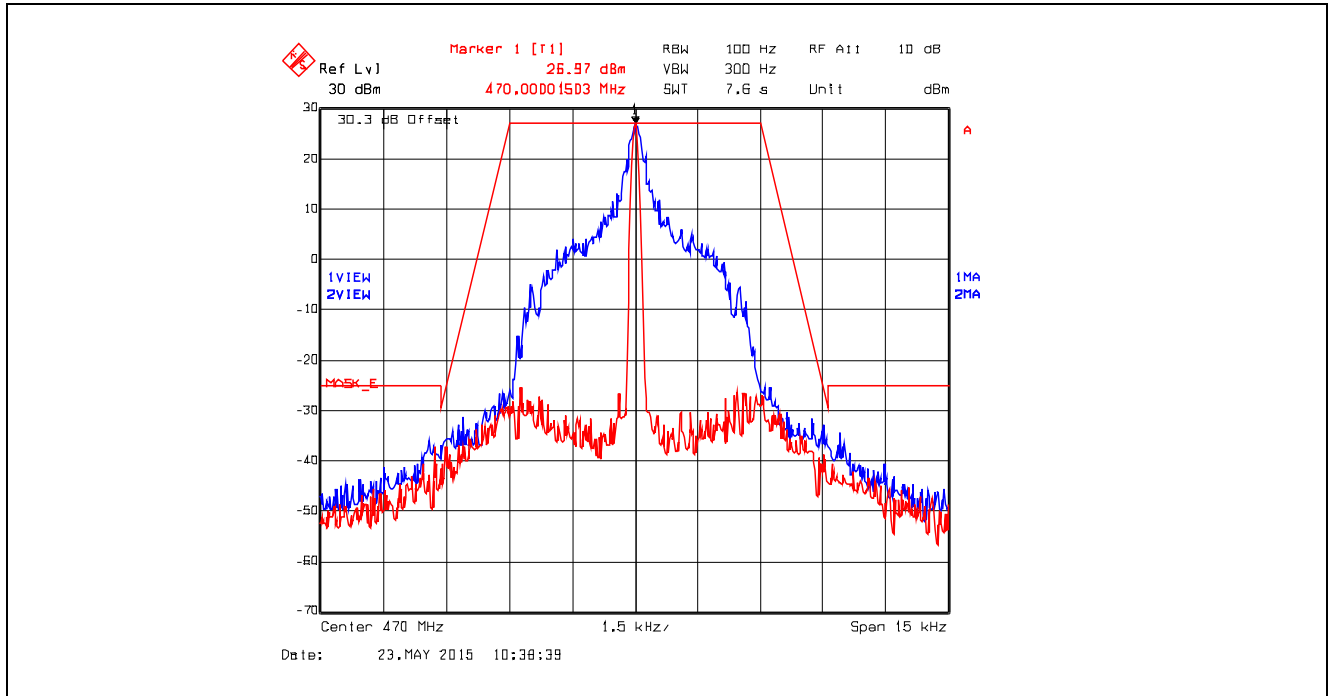

5.5. SPURIOUS EMISSIONS AT ANTENNA TERMINALS [§§ 2.1051, 2.1057, 90.210]

5.5.1. Limits

Emissions shall be attenuated below the mean output power of the transmitter as follows:

FCC Rules	Attenuation Limit (dBc)
§ 90.210(b)	At least $43 + 10 \log (P)$ dB
§ 90.210(c)	At least $43 + 10 \log (P)$ dB
§ 90.210(d)	At least $50 + 10 \log (P)$ dB or 70 dB, whichever is the lesser attenuation.
§ 90.210(e)	At least $55 + 10 \log (P)$ or 65 dB, whichever is the lesser attenuation.

5.5.2. Method of Measurements

Refer to Section 8.5 of this report for measurement details

5.5.3. Test Arrangement

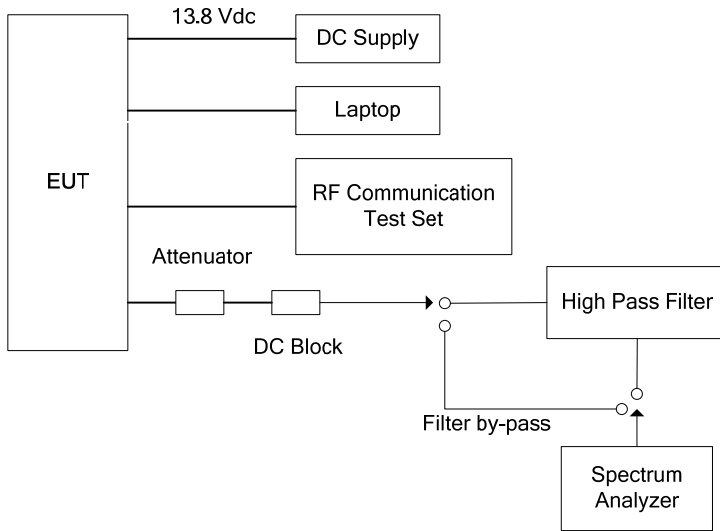

5.5.4. Test Data

Remark: Exploratory tests were conducted with modulations in the range of typical modes of operation to identify the worst-case modulation. There were no discernable differences detected. The digital mode, operating at 6.25 kHz channel spacing was used to represent the worst-case test configuration for the final measurement.

Plot 5.5.4.1. Conducted Transmitter Spurious Emissions, 380.1 MHz, High Power, 10 MHz – 400 MHz

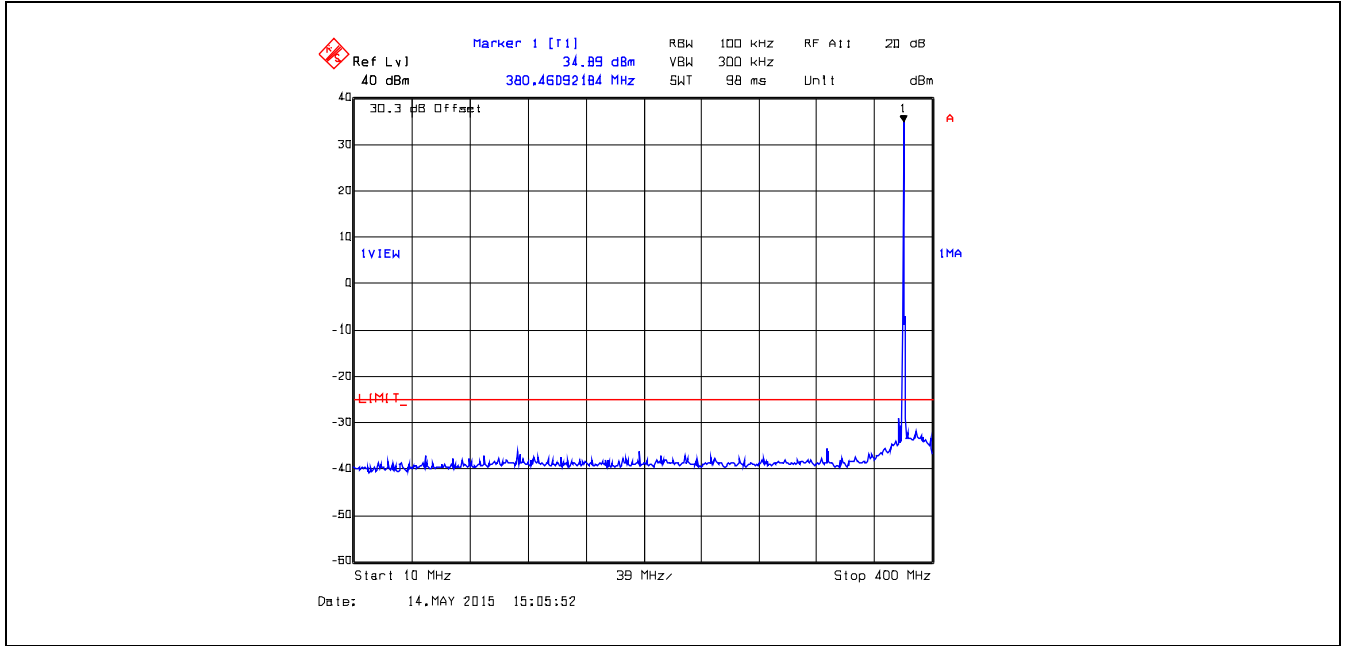

Plot 5.5.4.2. Conducted Transmitter Spurious Emissions, 380.1 MHz, High Power, 400 MHz – 1 GHz

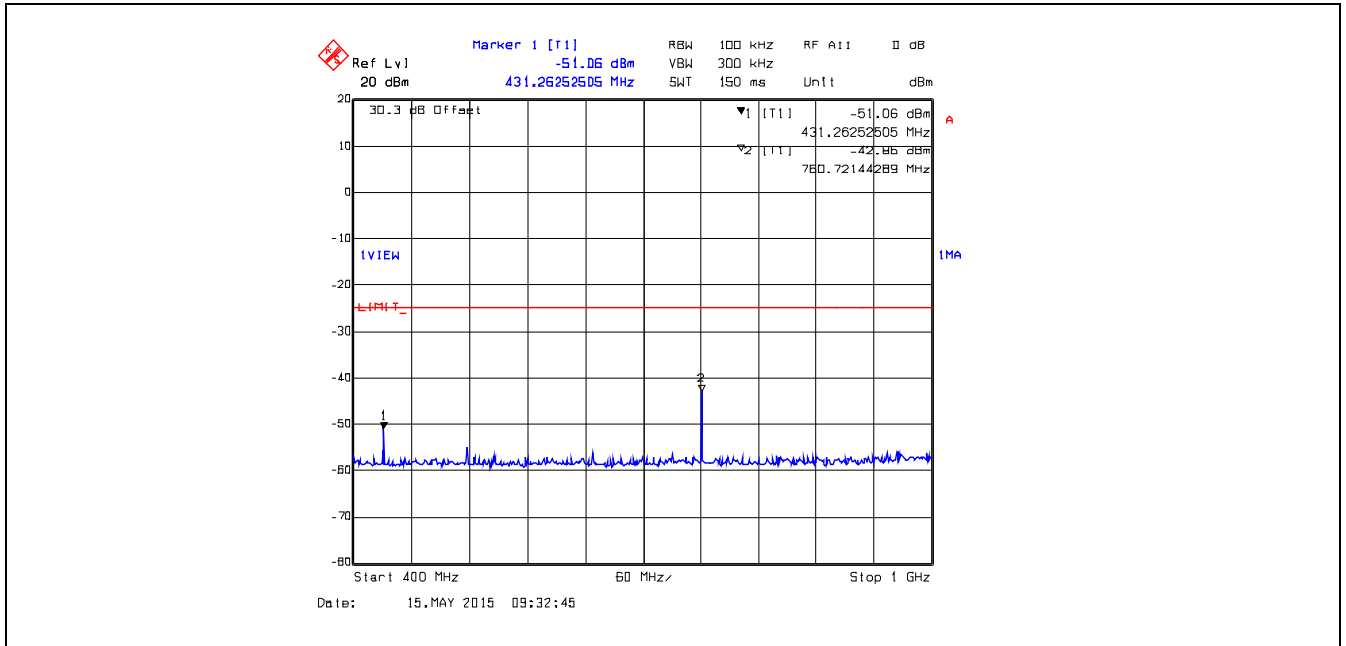

Plot 5.5.4.3. Conducted Transmitter Spurious Emissions, 380.1 MHz, High Power, 1 GHz – 6 GHz

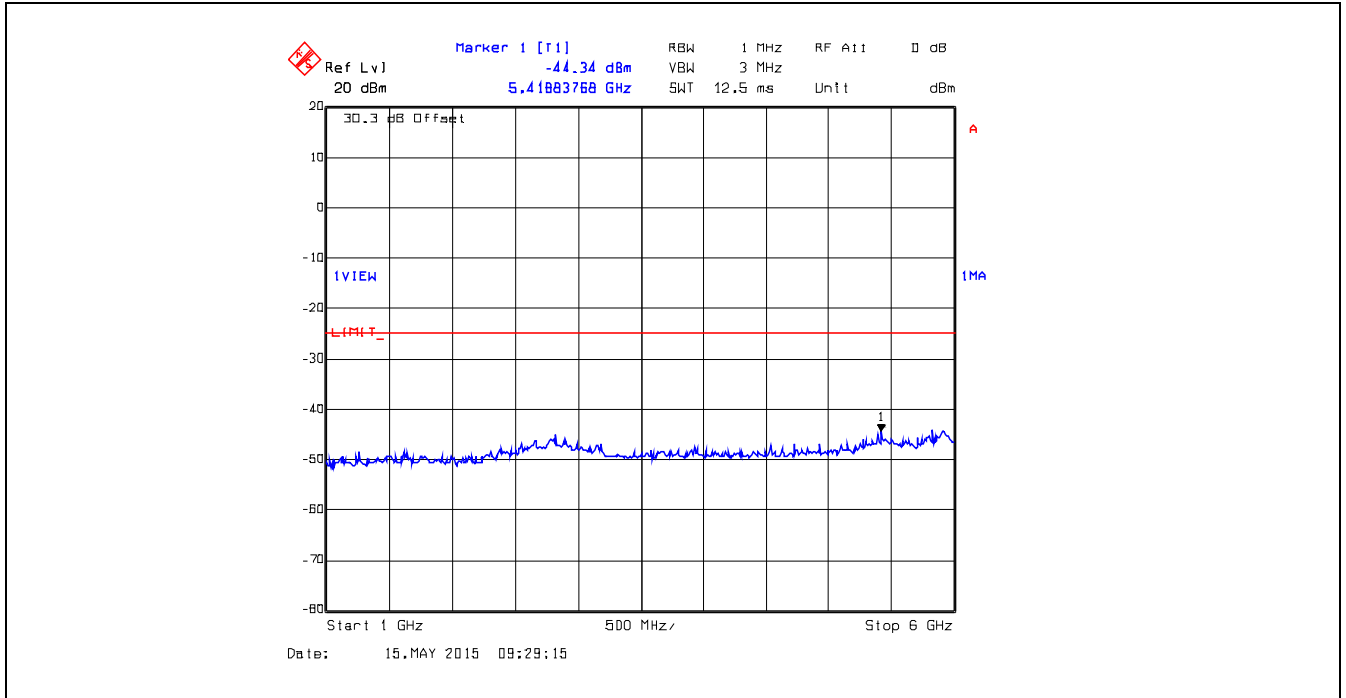

Plot 5.5.4.4. Conducted Transmitter Spurious Emissions, 380.1 MHz, Low Power, 10 MHz – 400 MHz

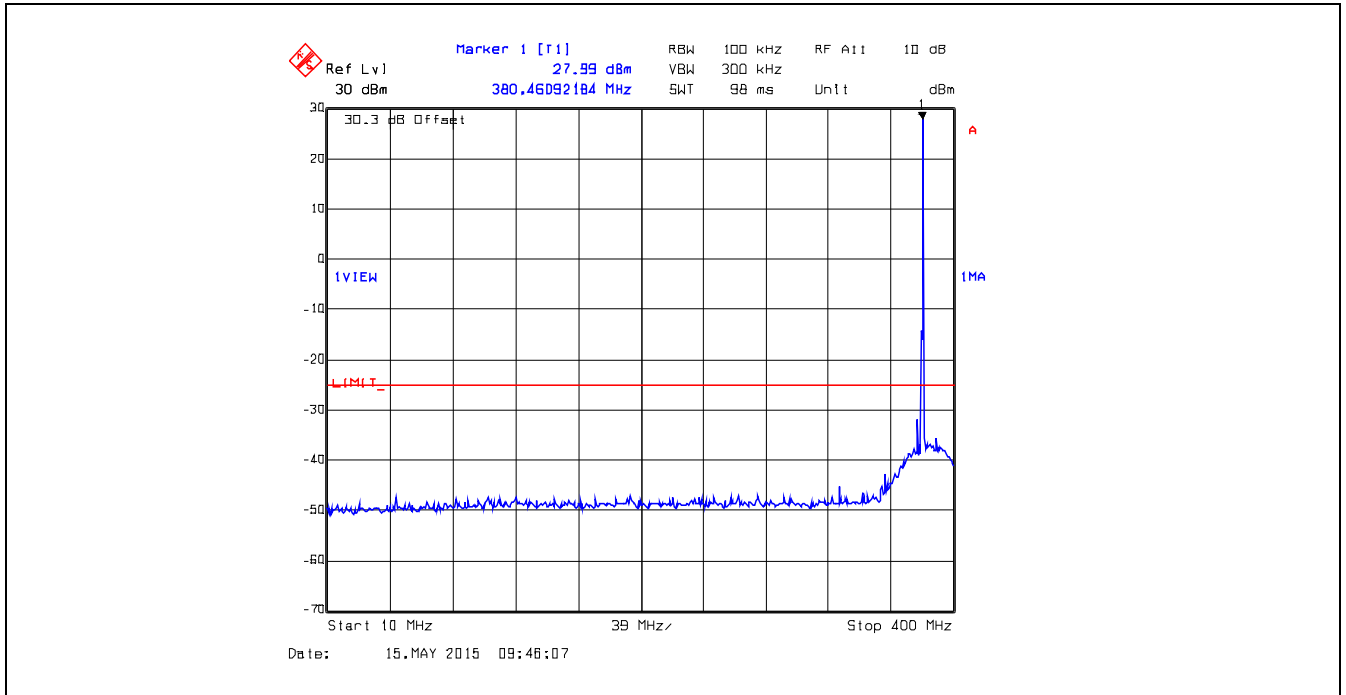

Plot 5.5.4.5. Conducted Transmitter Spurious Emissions, 380.1 MHz, Low Power, 400 MHz – 1 GHz

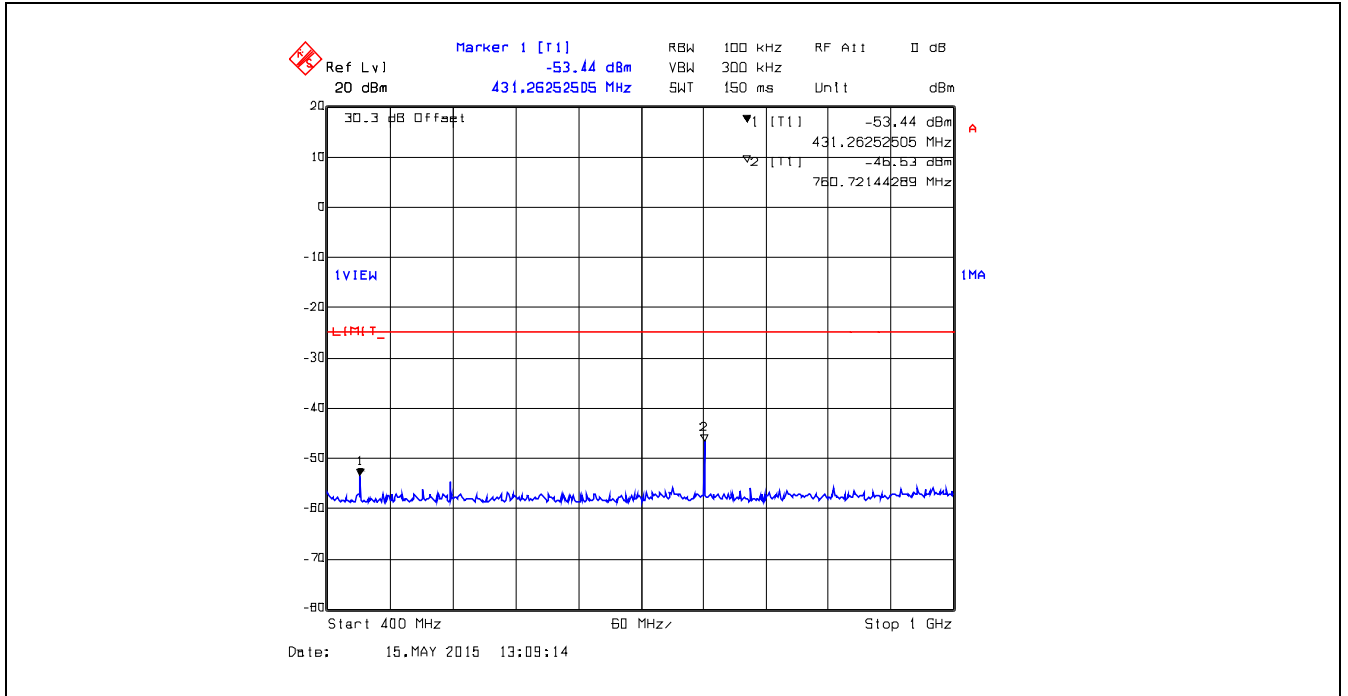

Plot 5.5.4.6. Conducted Transmitter Spurious Emissions, 380.1 MHz, Low Power, 1 GHz – 6 GHz

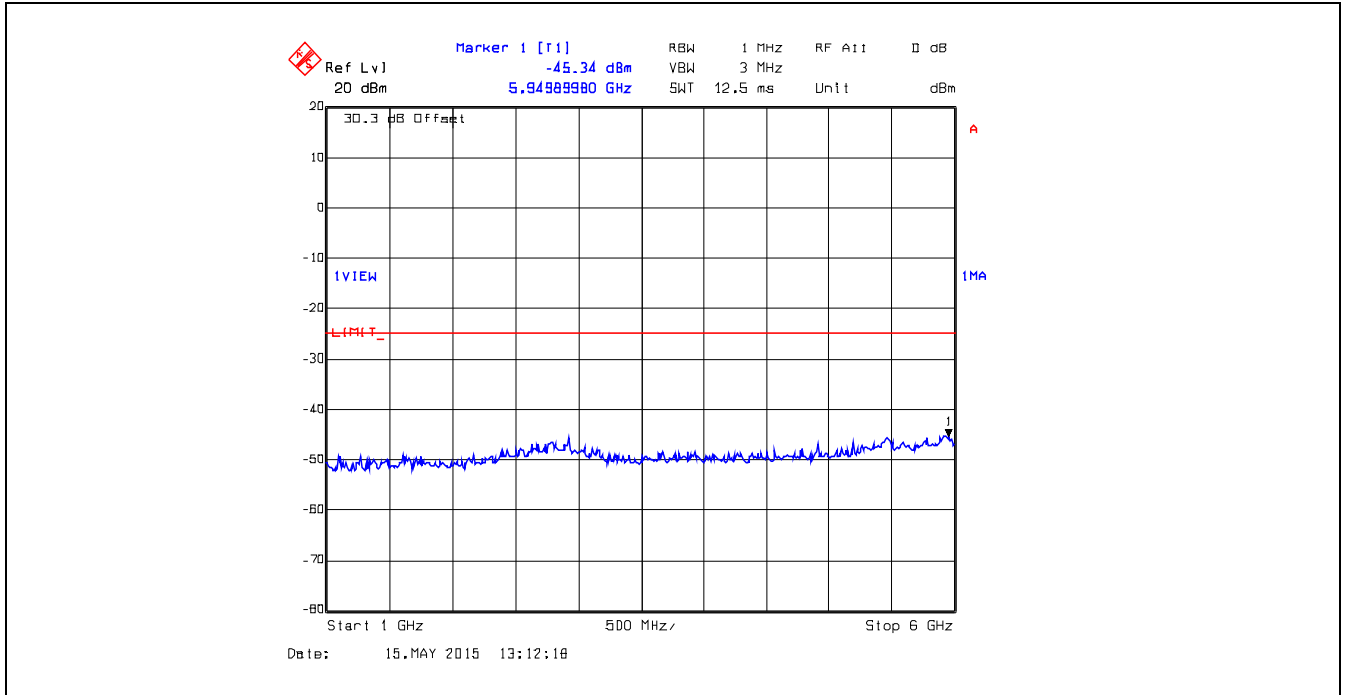

Plot 5.5.4.7. Conducted Transmitter Spurious Emissions, 390.0 MHz, High Power, 10 MHz – 400 MHz

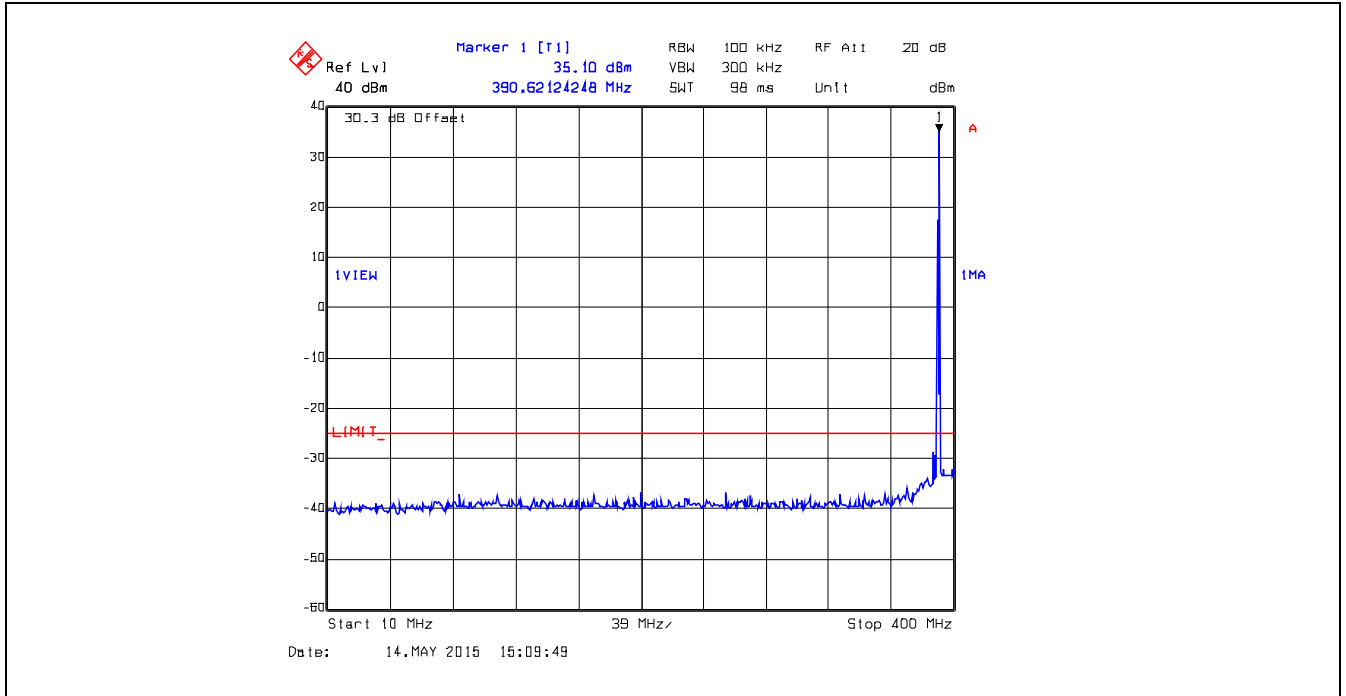

Plot 5.5.4.8. Conducted Transmitter Spurious Emissions, 390.0 MHz, High Power, 400 MHz – 1 GHz

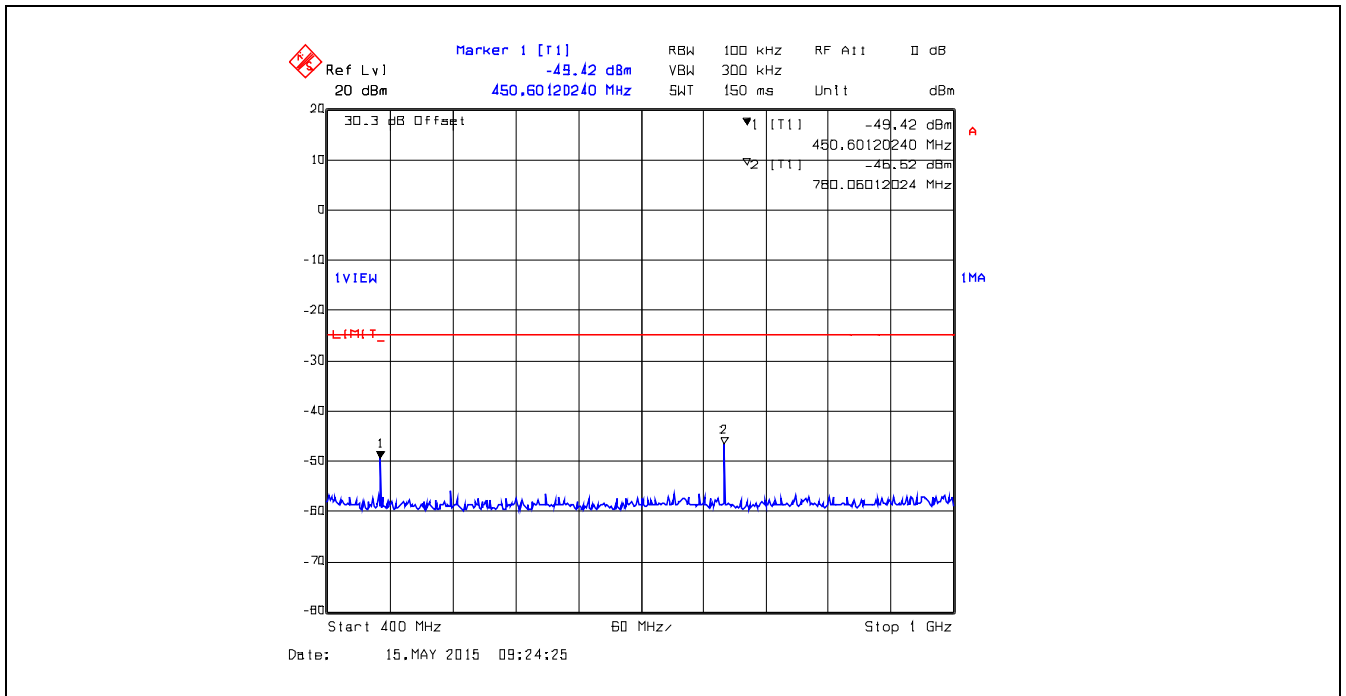

Plot 5.5.4.9. Conducted Transmitter Spurious Emissions, 390.0 MHz, High Power, 1 GHz – 6 GHz

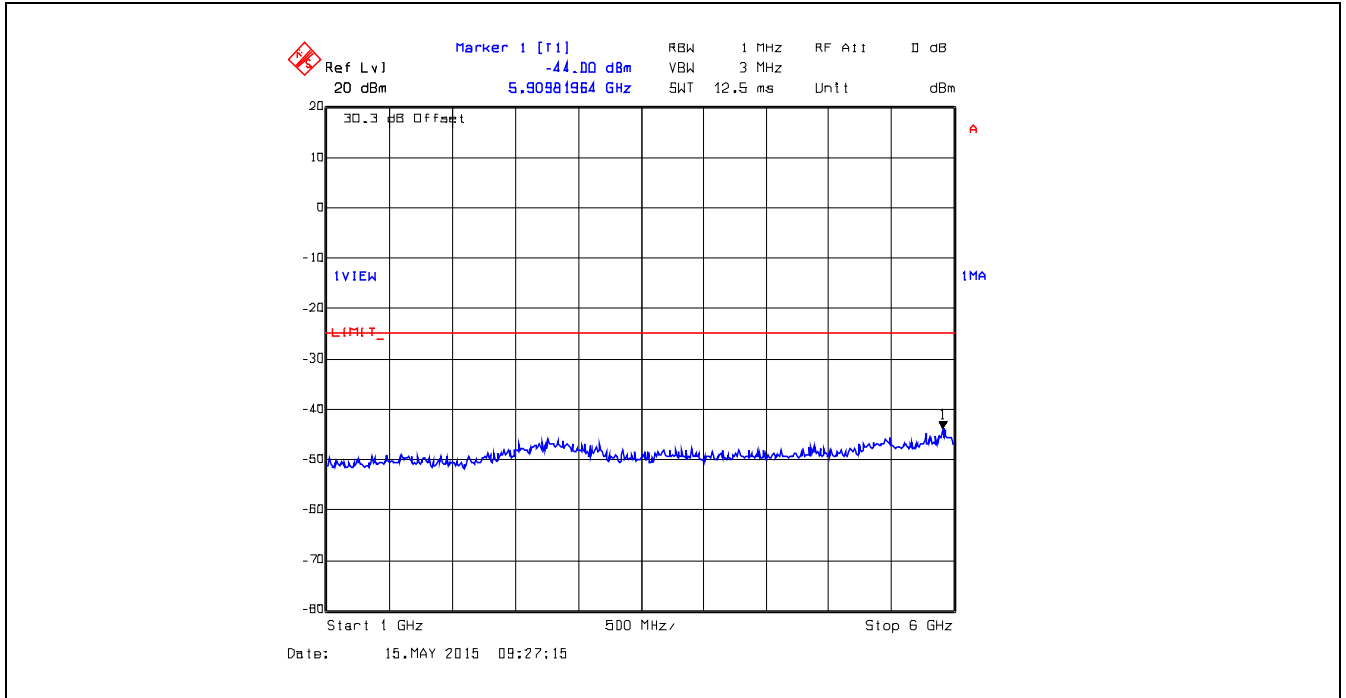

Plot 5.5.4.10. Conducted Transmitter Spurious Emissions, 390.0 MHz, Low Power, 10 MHz – 400 MHz

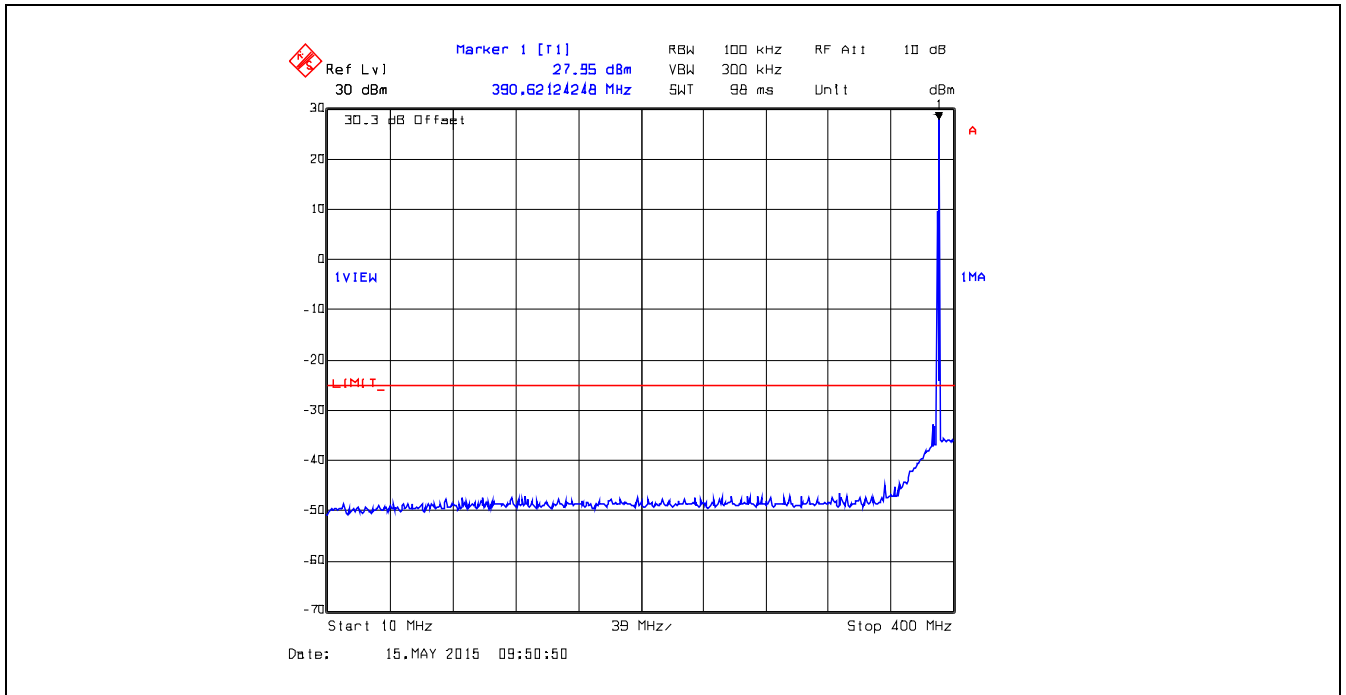

Plot 5.5.4.11. Conducted Transmitter Spurious Emissions, 390.0 MHz, Low Power, 400 MHz – 1 GHz

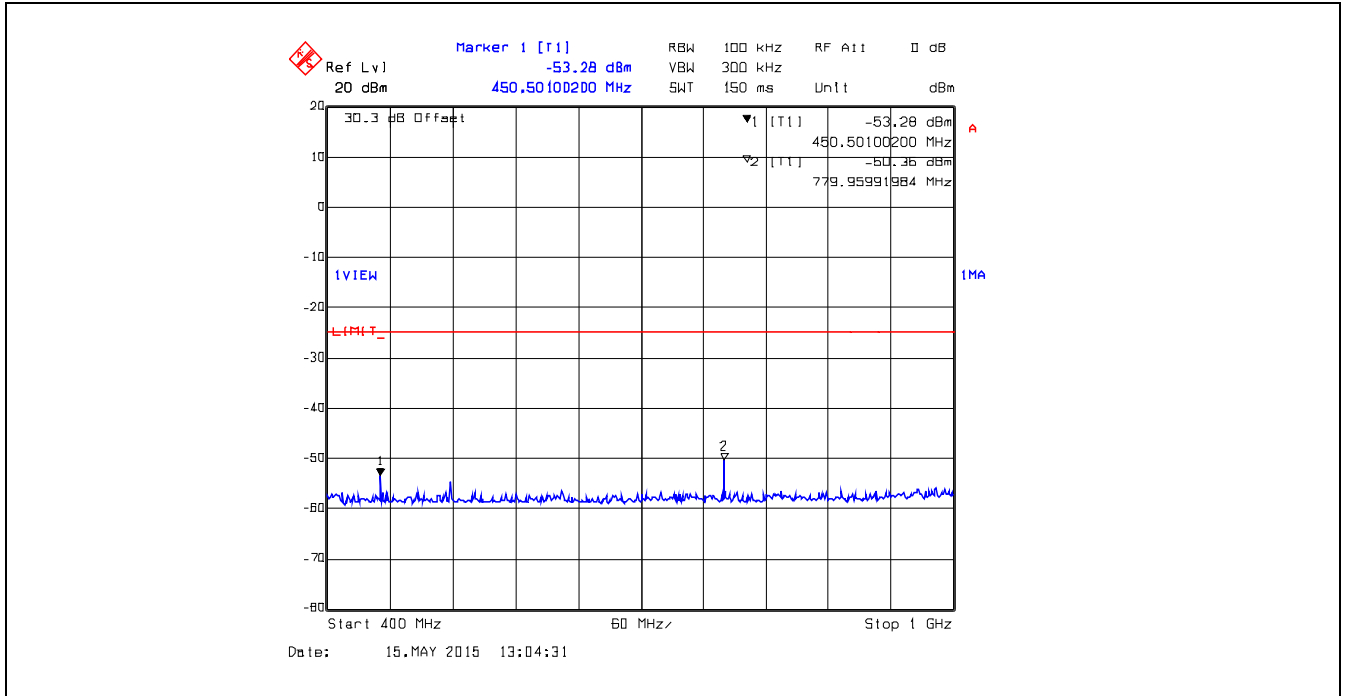

Plot 5.5.4.12. Conducted Transmitter Spurious Emissions, 390.0 MHz, Low Power, 1 GHz – 6 GHz

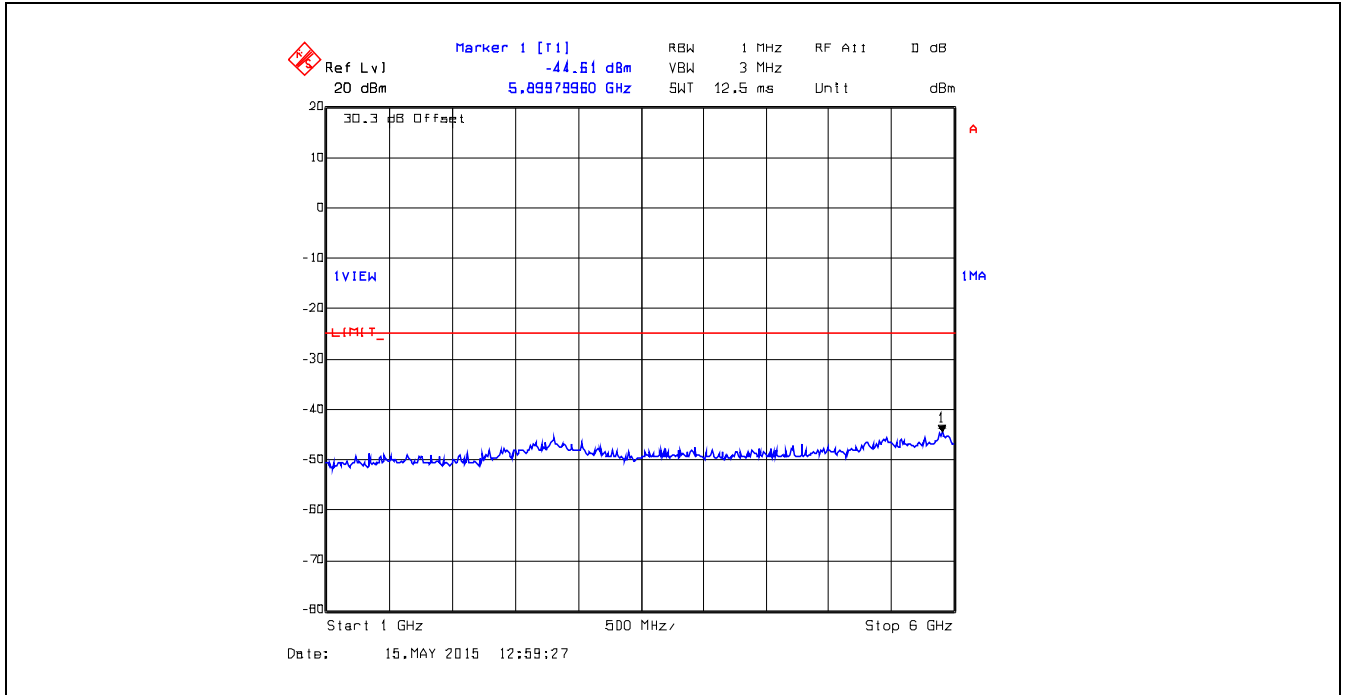

Plot 5.5.4.13. Conducted Transmitter Spurious Emissions, 399.9 MHz, High Power, 10 MHz – 450 MHz

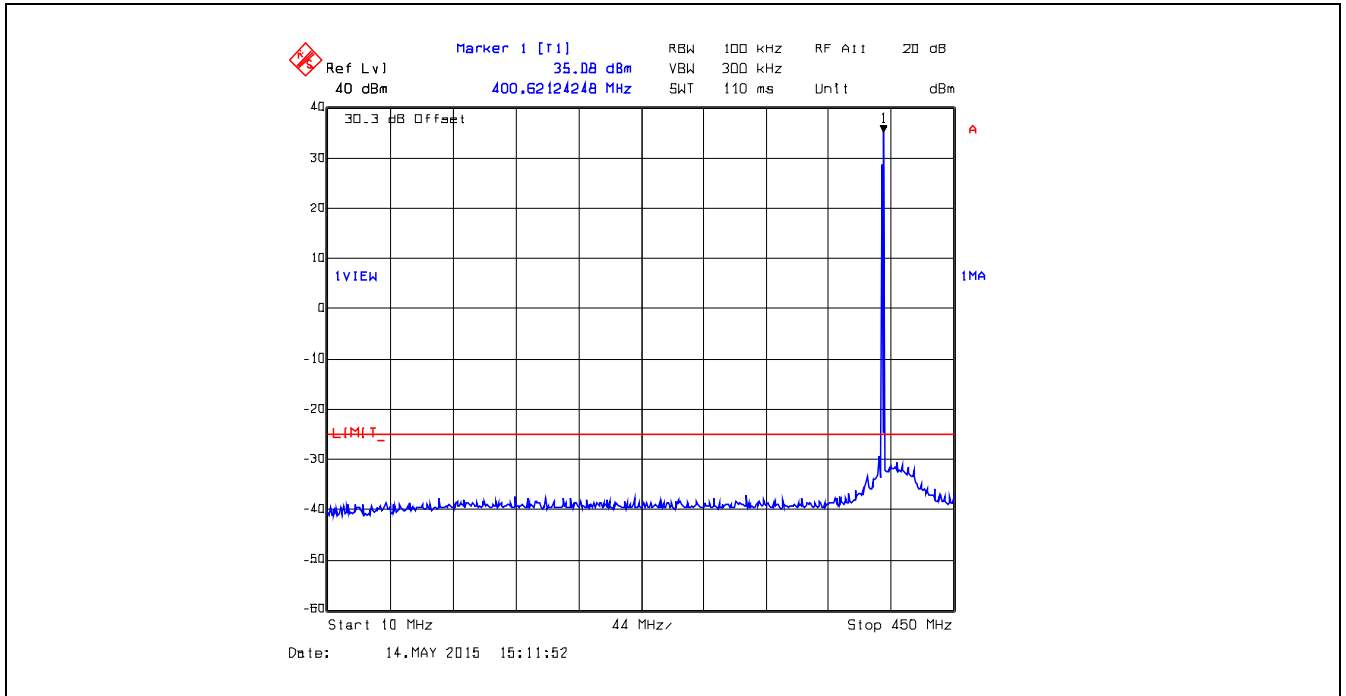

Plot 5.5.4.14. Conducted Transmitter Spurious Emissions, 399.9 MHz, High Power, 450 MHz – 1 GHz

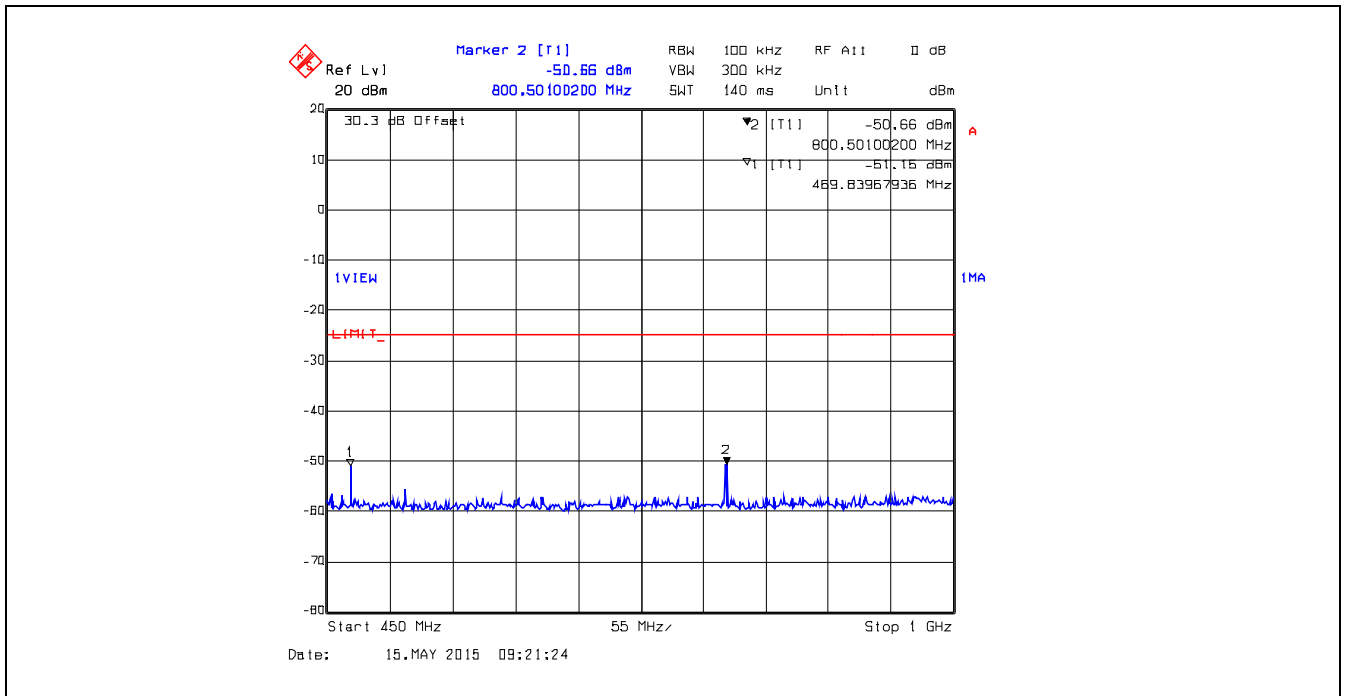

Plot 5.5.4.15. Conducted Transmitter Spurious Emissions, 399.9 MHz, High Power, 1 GHz – 6 GHz

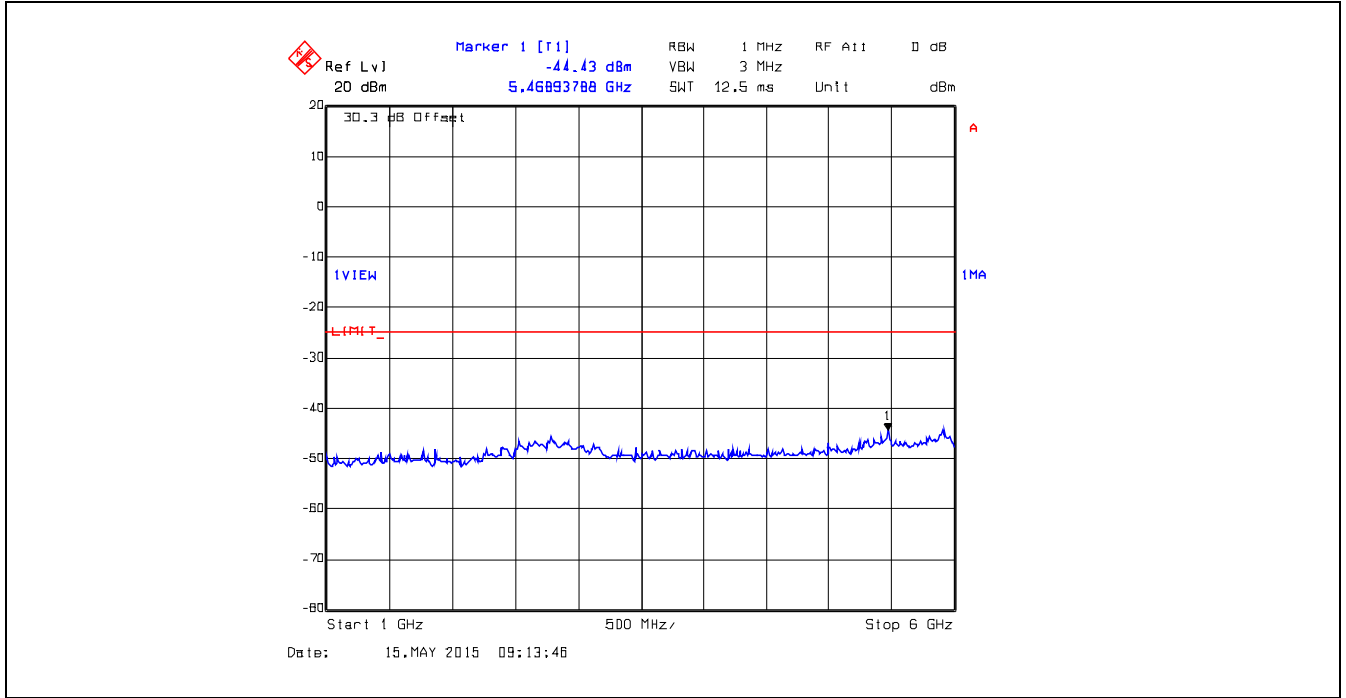

Plot 5.5.4.16. Conducted Transmitter Spurious Emissions, 399.9 MHz, Low Power, 10 MHz – 450 MHz

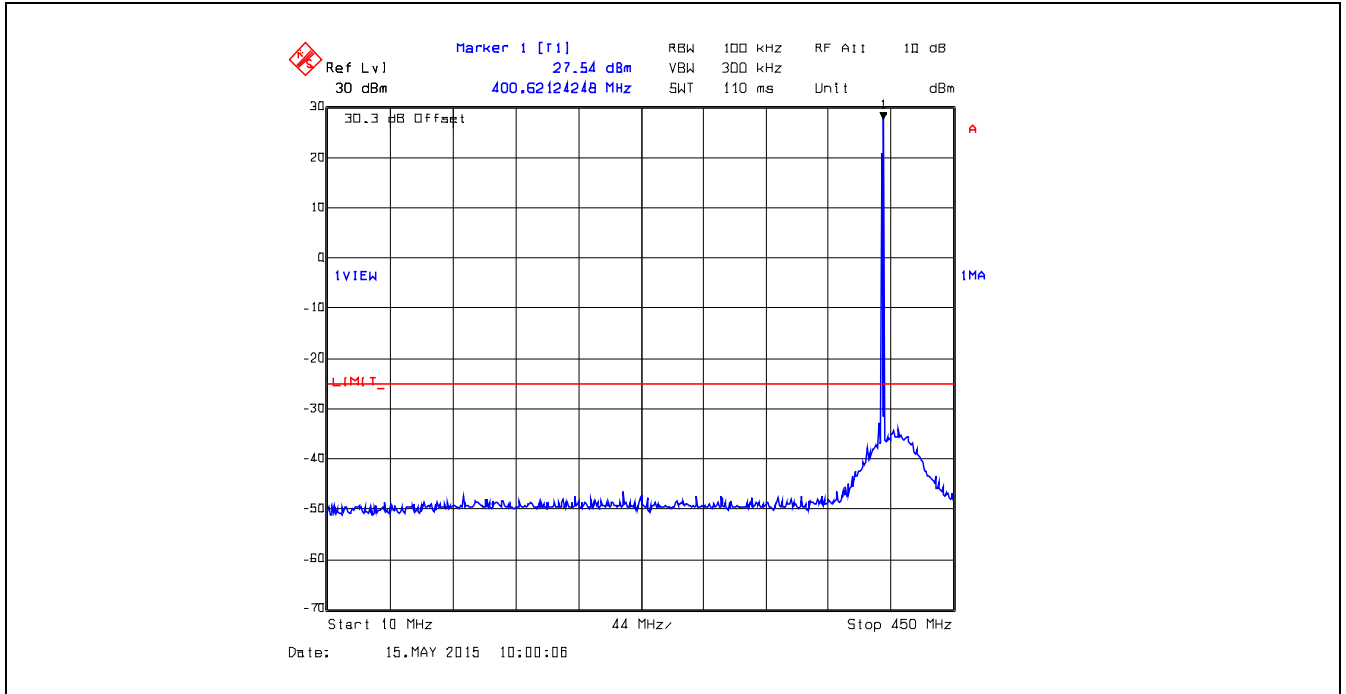

ULTRATECH GROUP OF LABS

3000 Bristol Circle, Oakville, Ontario, Canada L6H 6G4
Tel. #: 905-829-1570, Fax. #: 905-829-8050, Email: vic@ultratech-labs.com, Website: <http://www.ultratech-labs.com>

File #: 15FSG141_FCC90
July 8, 2015

All test results contained in this engineering test report are traceable to National Institute of Standards and Technology (NIST)

Plot 5.5.4.17. Conducted Transmitter Spurious Emissions, 399.9 MHz, Low Power, 450 MHz – 1 GHz

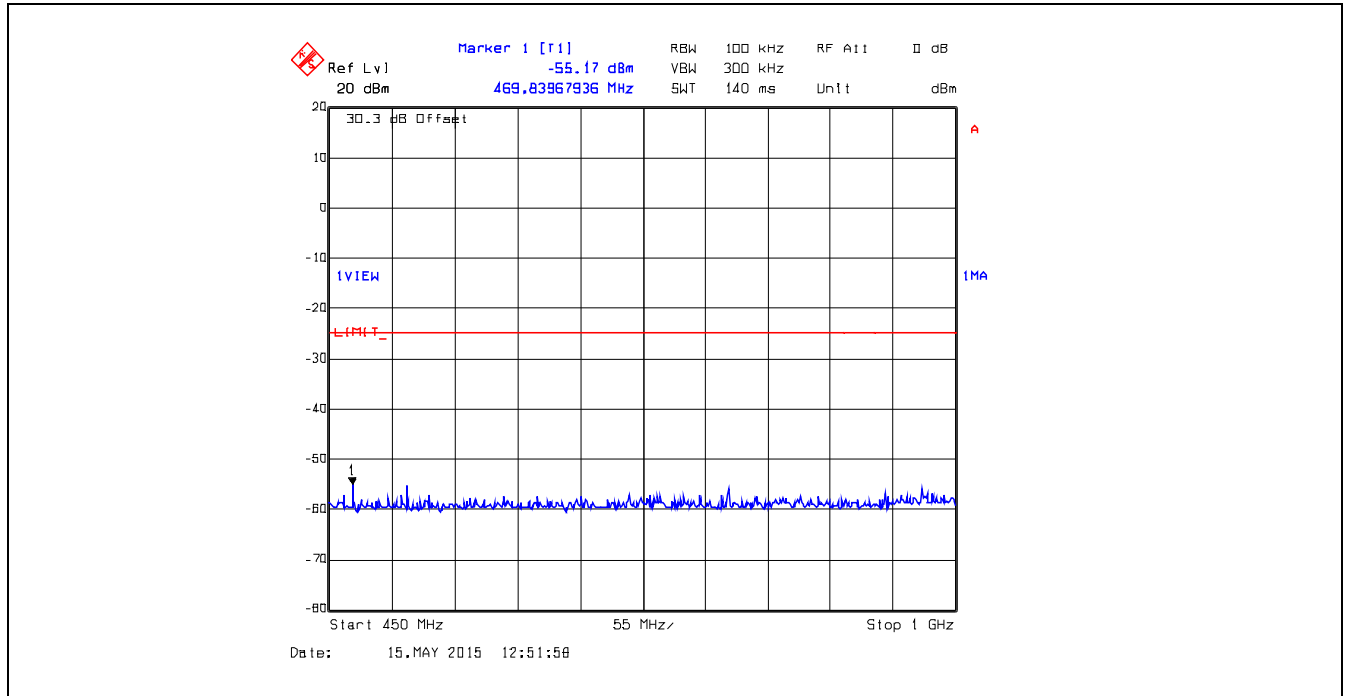

Plot 5.5.4.18. Conducted Transmitter Spurious Emissions, 399.9 MHz, Low Power, 1 GHz – 6 GHz

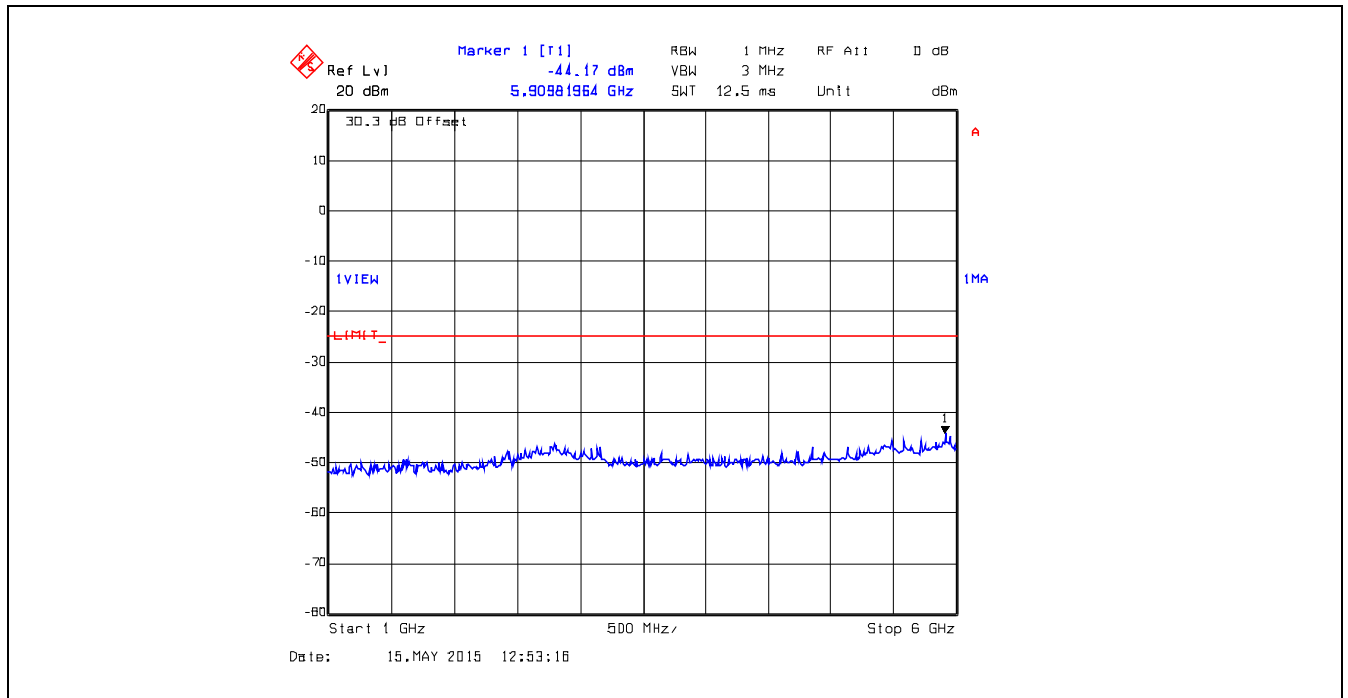

Plot 5.5.4.19. Conducted Transmitter Spurious Emissions, 406.2 MHz, High Power, 10 MHz – 450 MHz

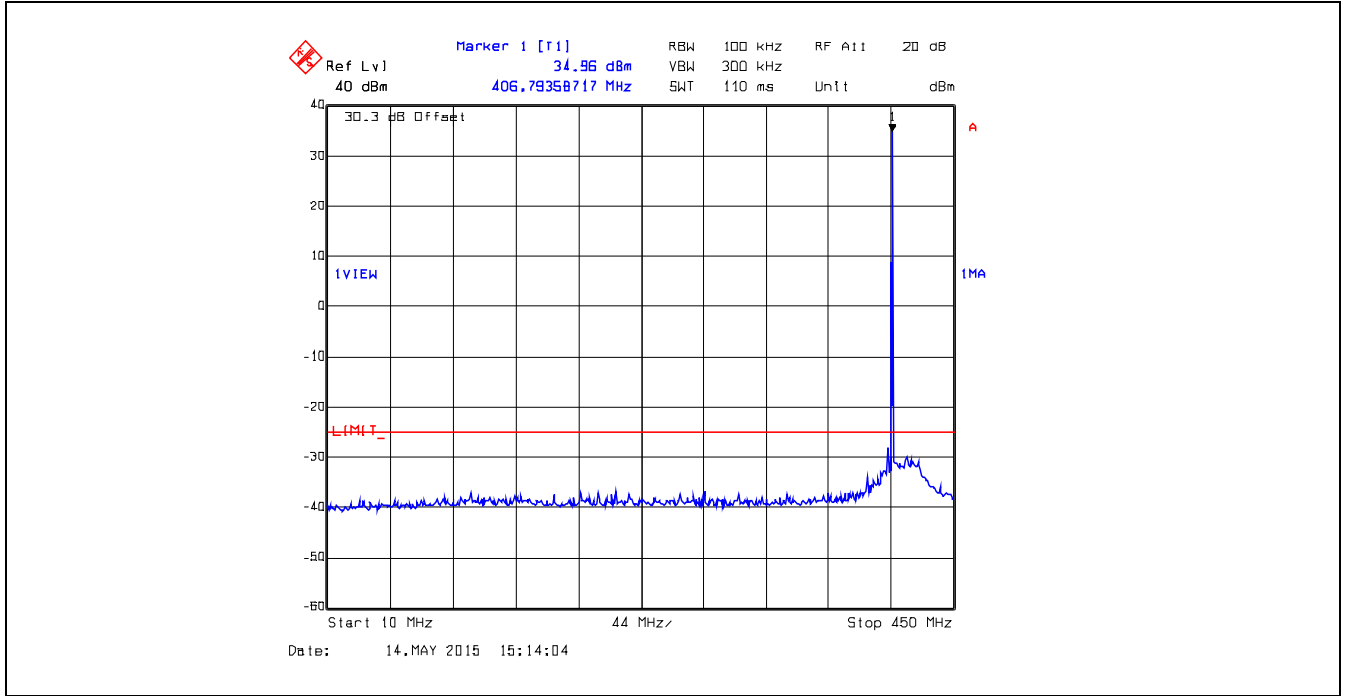

Plot 5.5.4.20. Conducted Transmitter Spurious Emissions, 406.2 MHz, High Power, 450 MHz – 1 GHz

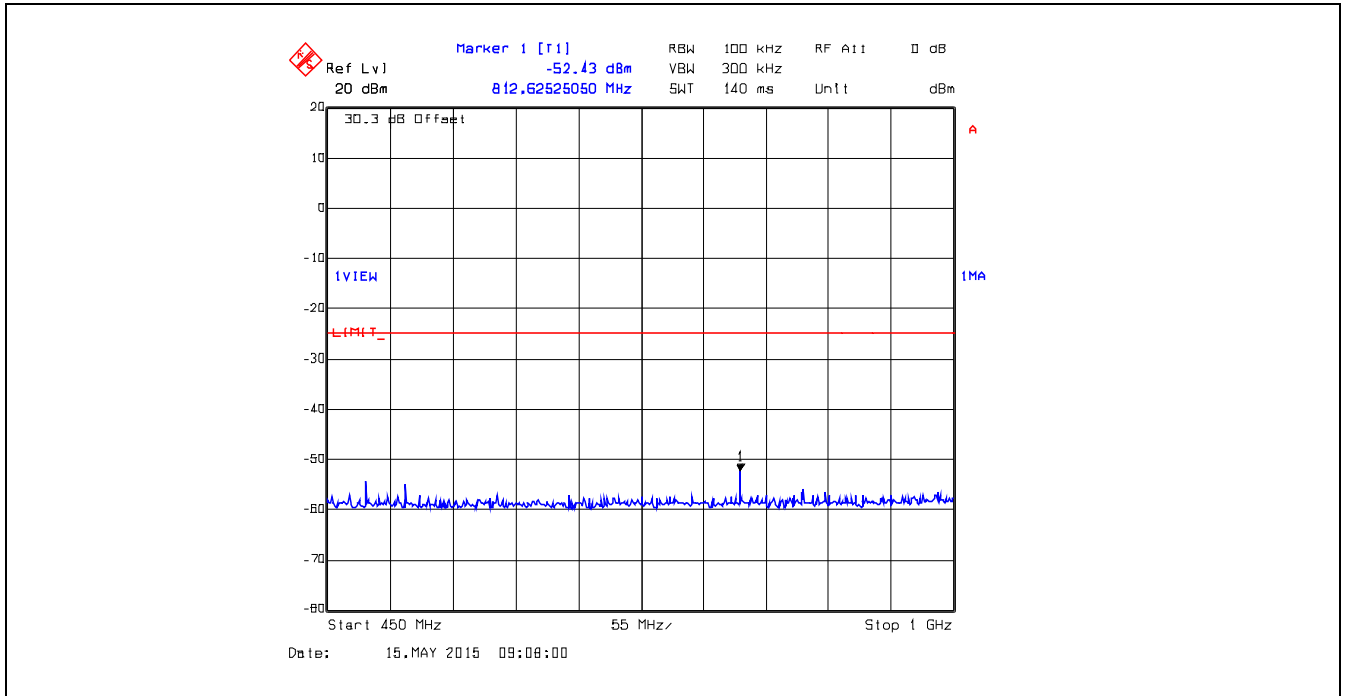

ULTRATECH GROUP OF LABS

3000 Bristol Circle, Oakville, Ontario, Canada L6H 6G4
Tel. #: 905-829-1570, Fax. #: 905-829-8050, Email: vic@ultratech-labs.com, Website: <http://www.ultratech-labs.com>

File #: 15FSG141_FCC90

July 8, 2015

All test results contained in this engineering test report are traceable to National Institute of Standards and Technology (NIST)

Plot 5.5.4.21. Conducted Transmitter Spurious Emissions, 406.2 MHz, High Power, 1 GHz – 6 GHz

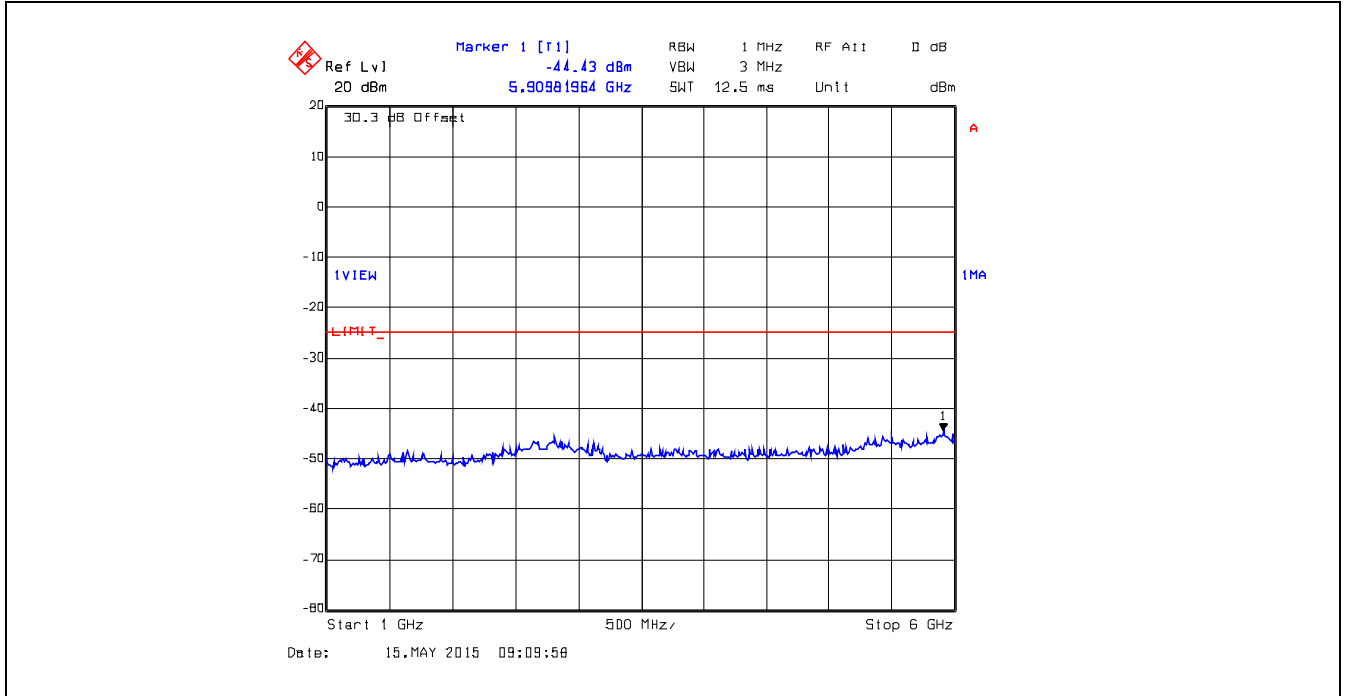

Plot 5.5.4.22. Conducted Transmitter Spurious Emissions, 406.2 MHz, Low Power, 10 MHz – 450 MHz

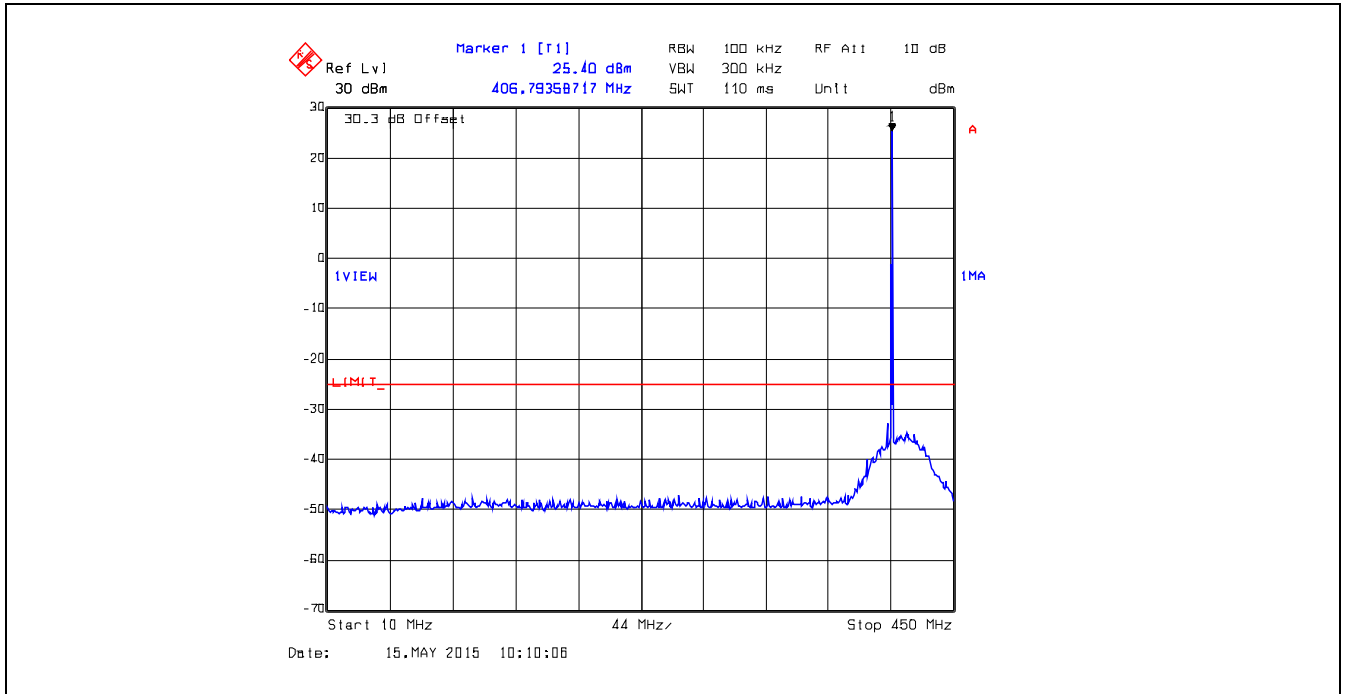

Plot 5.5.4.23. Conducted Transmitter Spurious Emissions, 406.2 MHz, Low Power, 450 MHz – 1 GHz

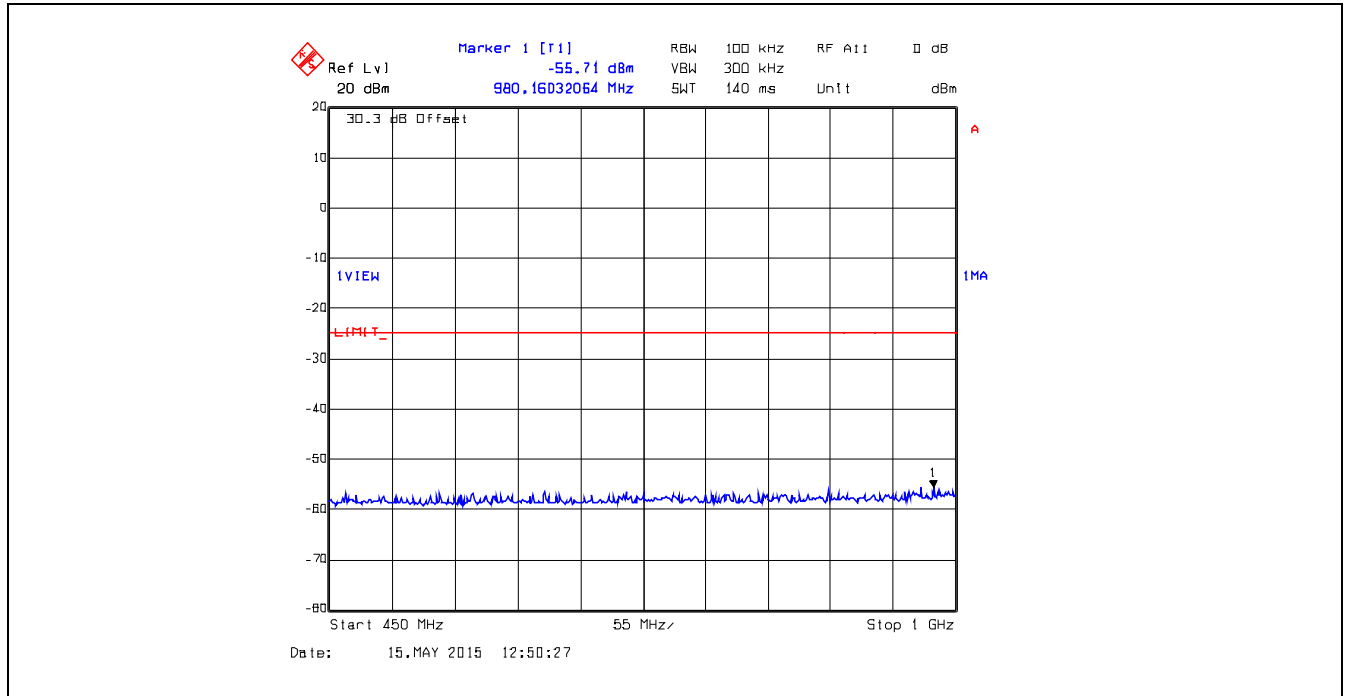

Plot 5.5.4.24. Conducted Transmitter Spurious Emissions, 406.2 MHz, Low Power, 1 GHz – 6 GHz

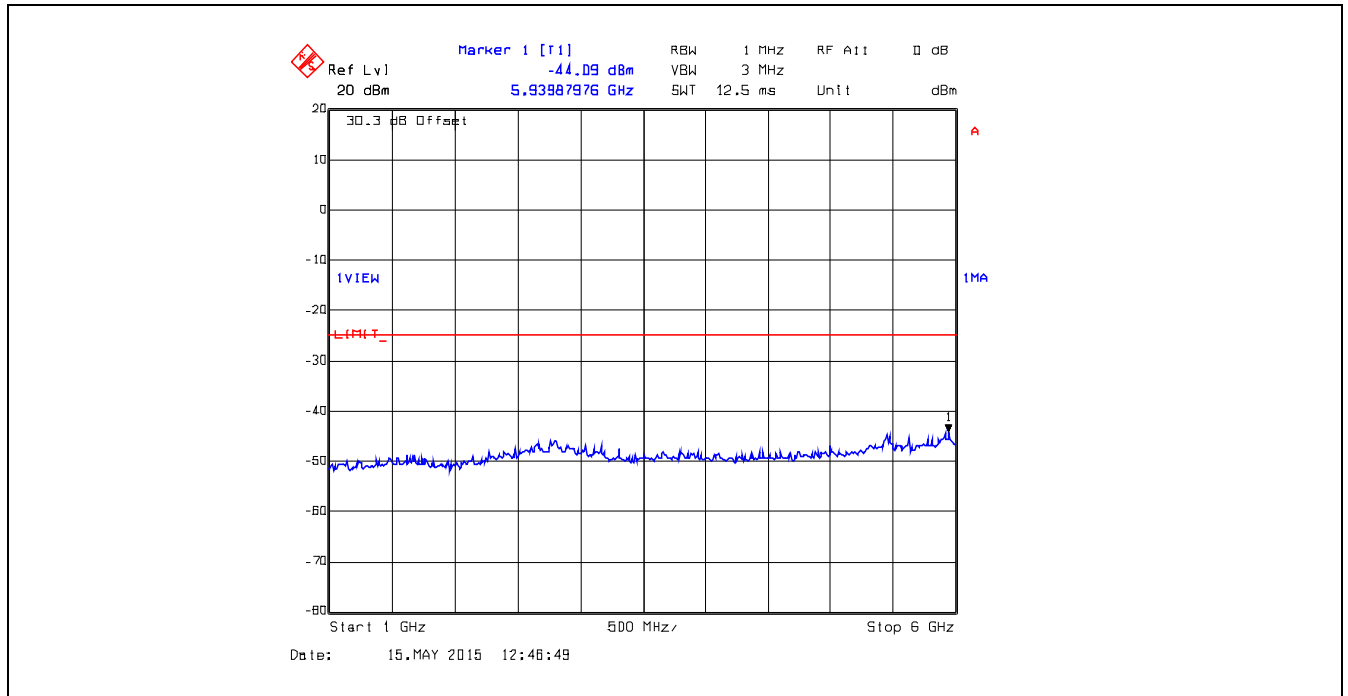

Plot 5.5.4.25. Conducted Transmitter Spurious Emissions, 415.0 MHz, High Power, 10 MHz – 450 MHz

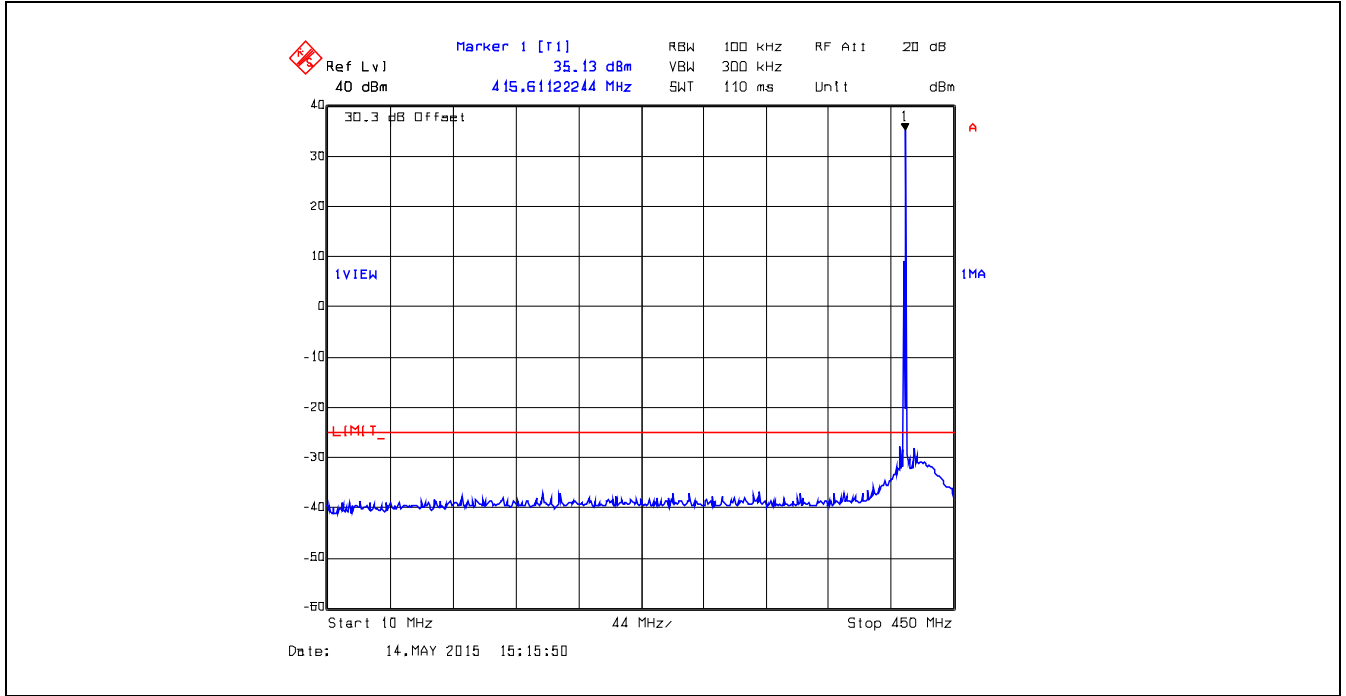

Plot 5.5.4.26. Conducted Transmitter Spurious Emissions, 415.0 MHz, High Power, 450 MHz – 1 GHz

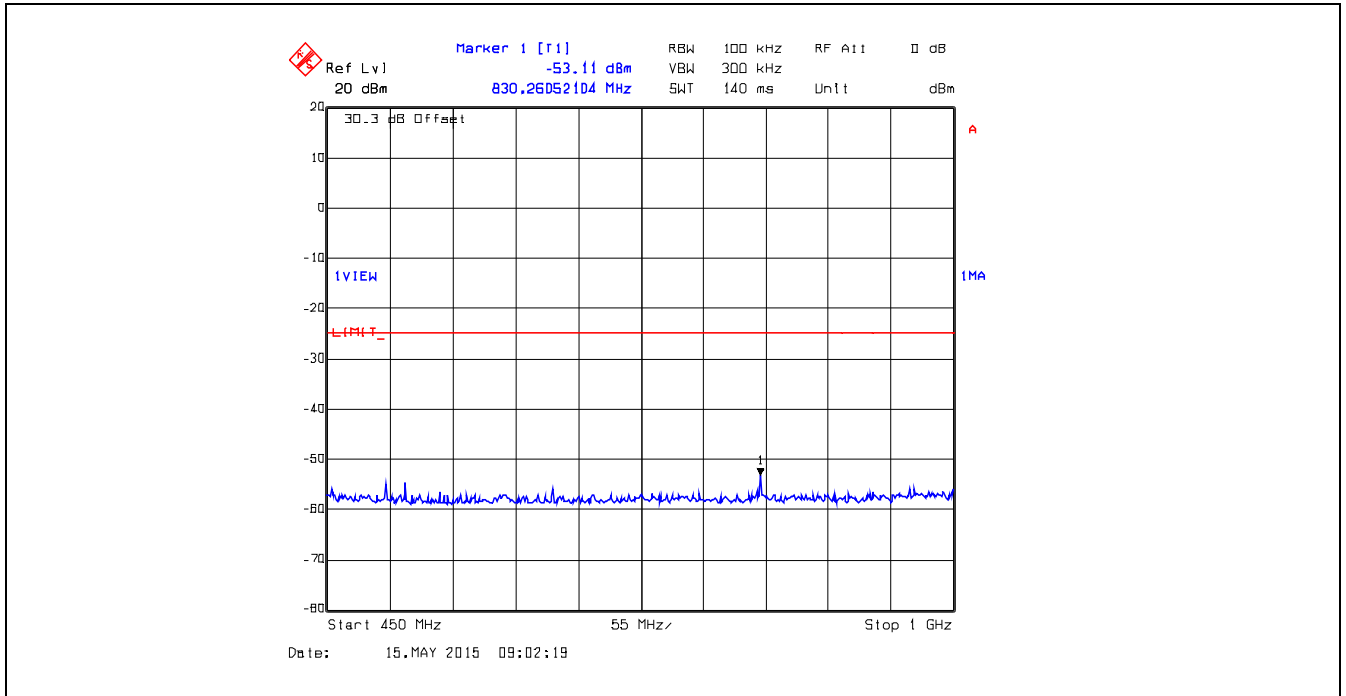

Plot 5.5.4.27. Conducted Transmitter Spurious Emissions, 415.0 MHz, High Power, 1 GHz – 6 GHz

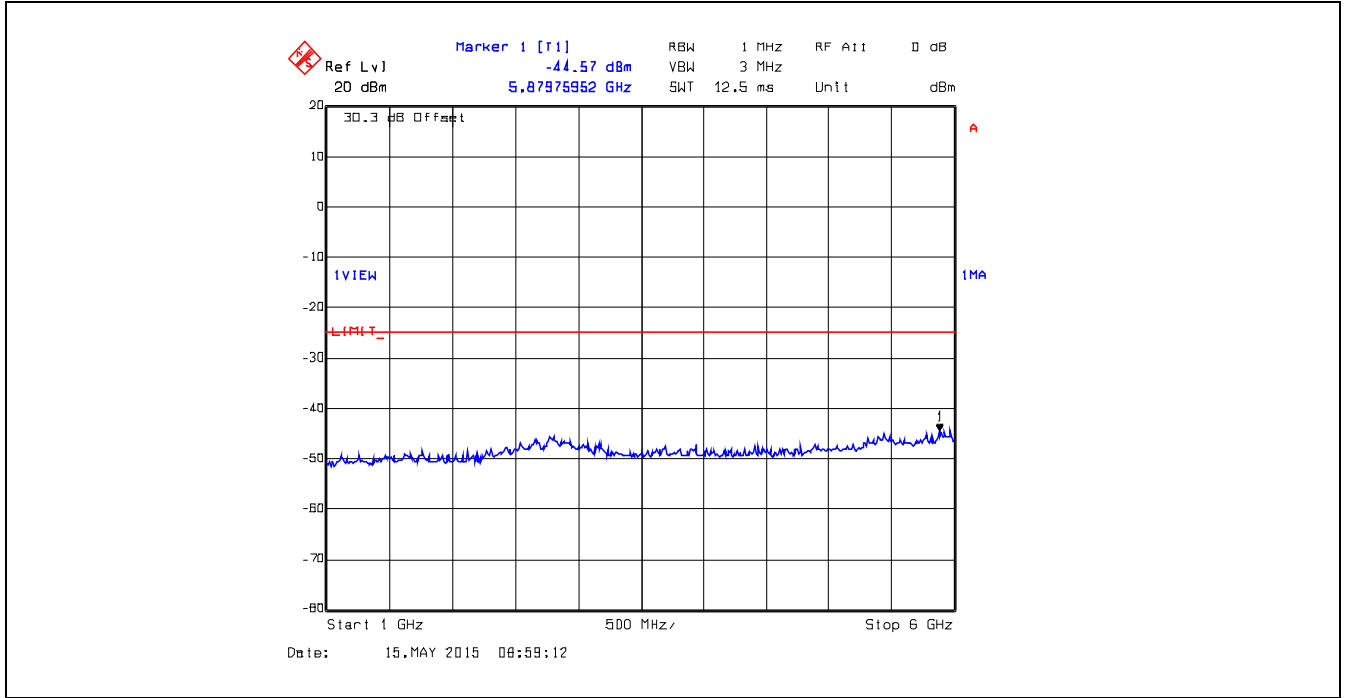

Plot 5.5.4.28. Conducted Transmitter Spurious Emissions, 415.0 MHz, Low Power, 10 MHz – 450 MHz

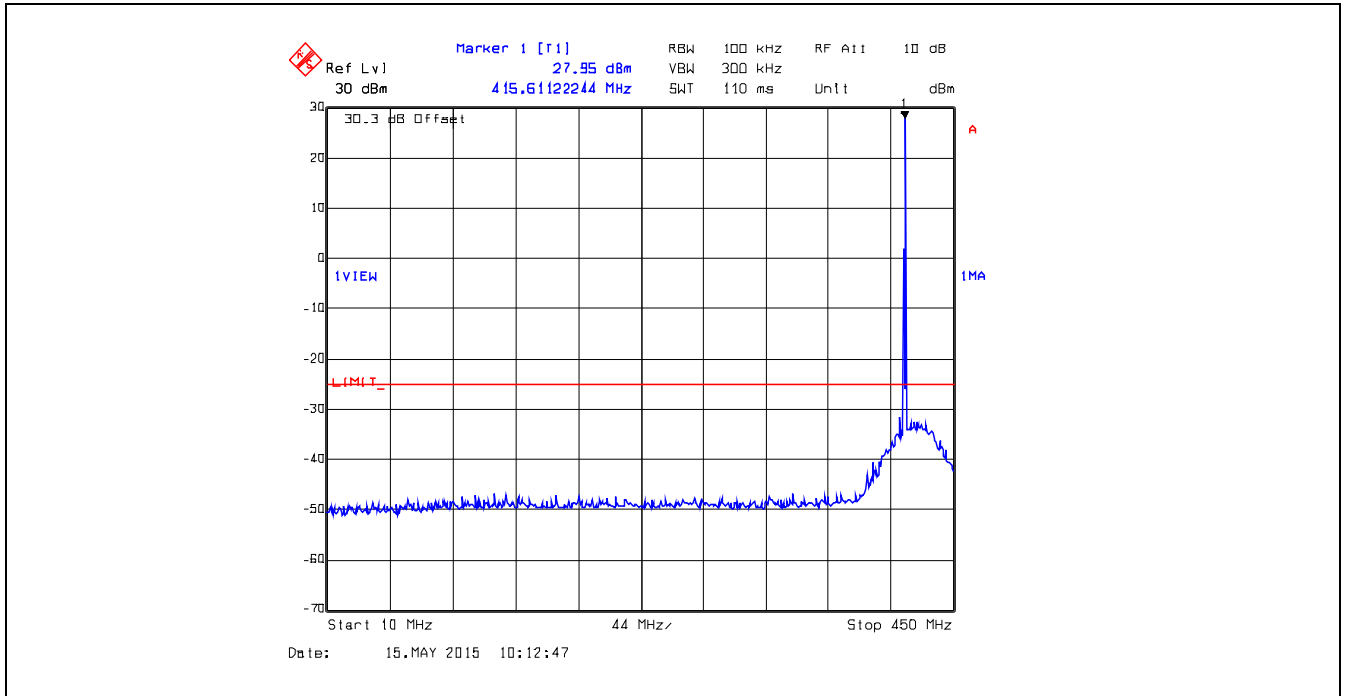

Plot 5.5.4.29. Conducted Transmitter Spurious Emissions, 415.0 MHz, Low Power, 450 MHz – 1 GHz

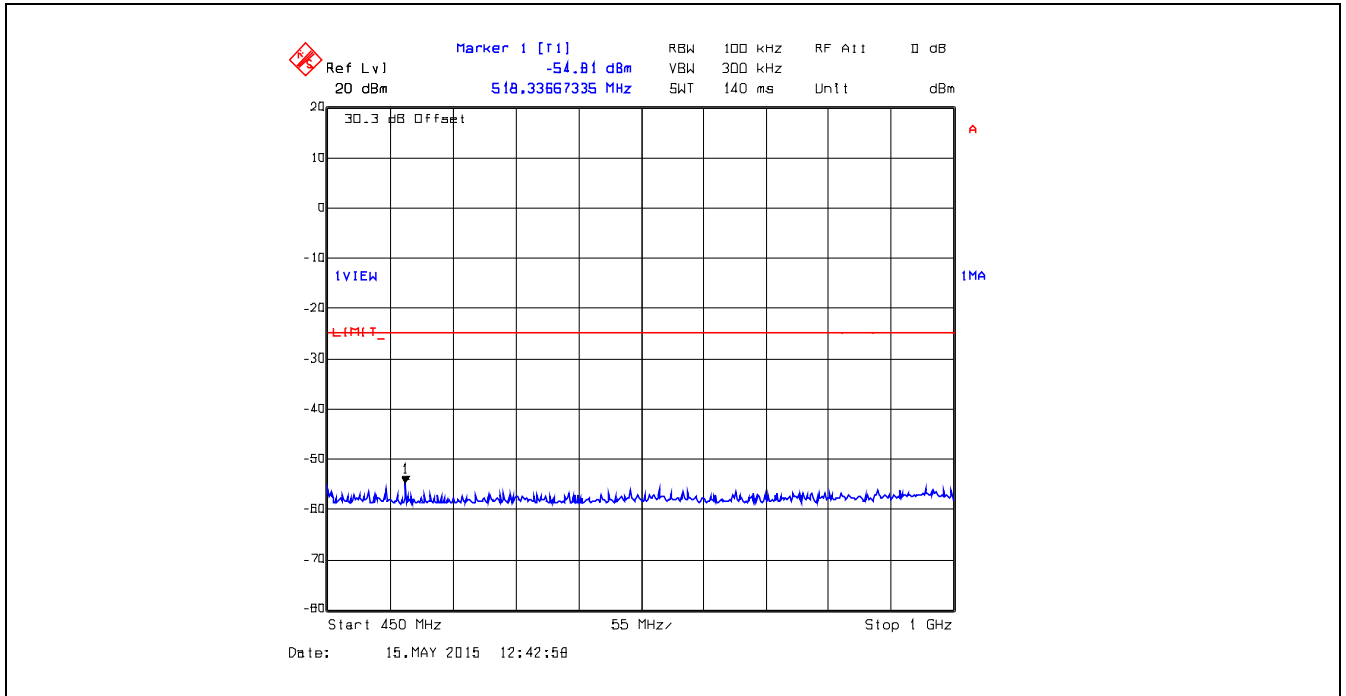

Plot 5.5.4.30. Conducted Transmitter Spurious Emissions, 415.0 MHz, Low Power, 1 GHz – 6 GHz

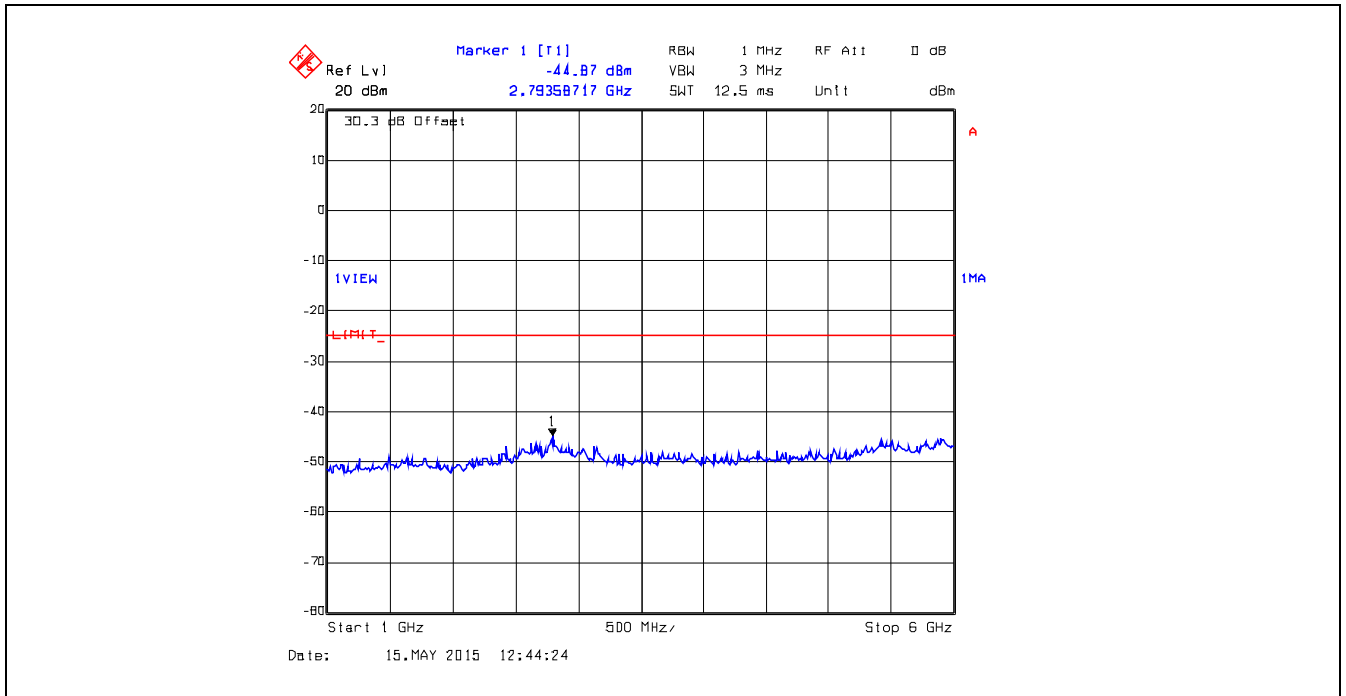

Plot 5.5.4.31. Conducted Transmitter Spurious Emissions, 429.9 MHz, High Power, 10 MHz – 450 MHz

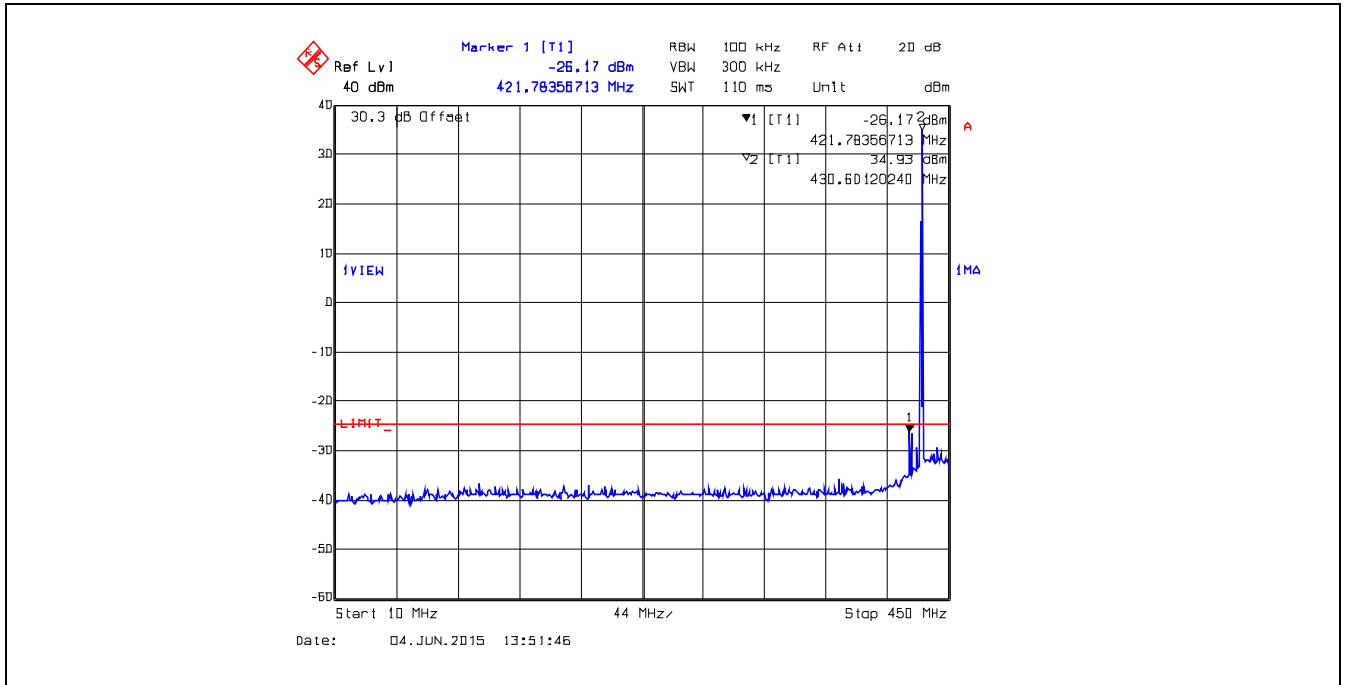

Plot 5.5.4.32. Conducted Transmitter Spurious Emissions, 429.9 MHz, High Power, 450 MHz – 1 GHz

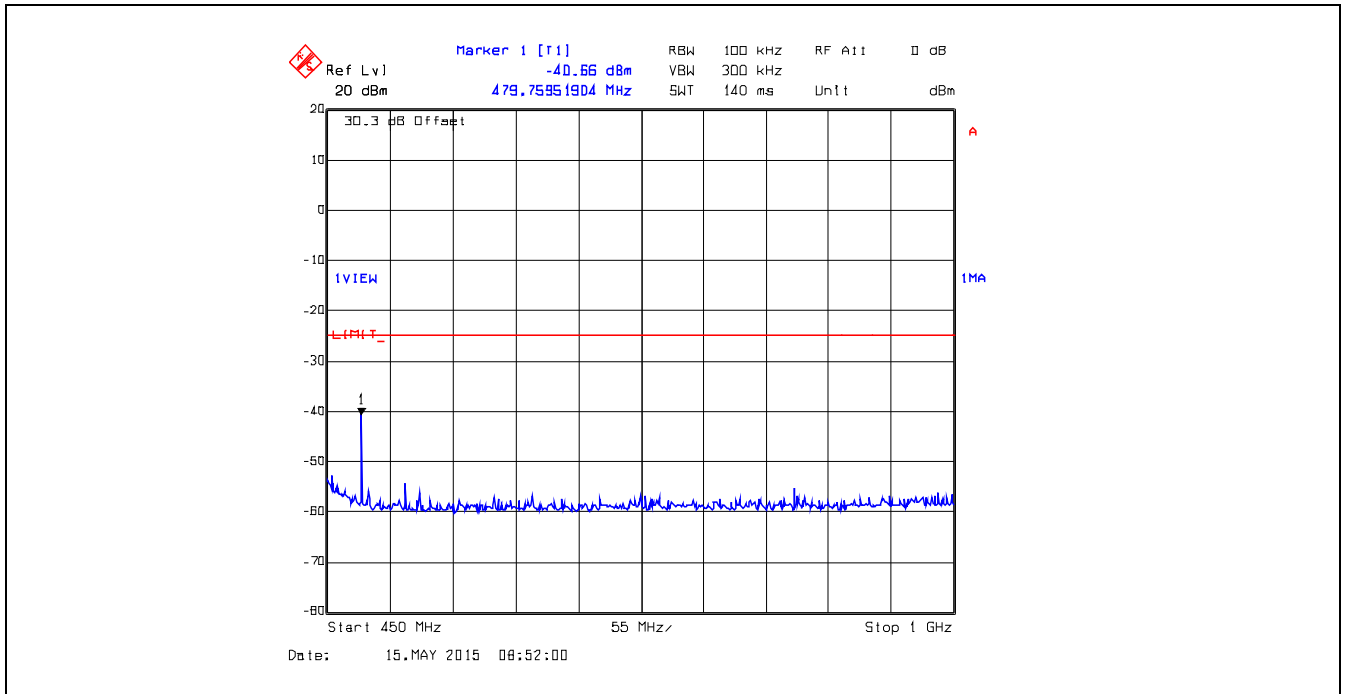

Plot 5.5.4.33. Conducted Transmitter Spurious Emissions, 429.9 MHz, High Power, 1 GHz – 6 GHz

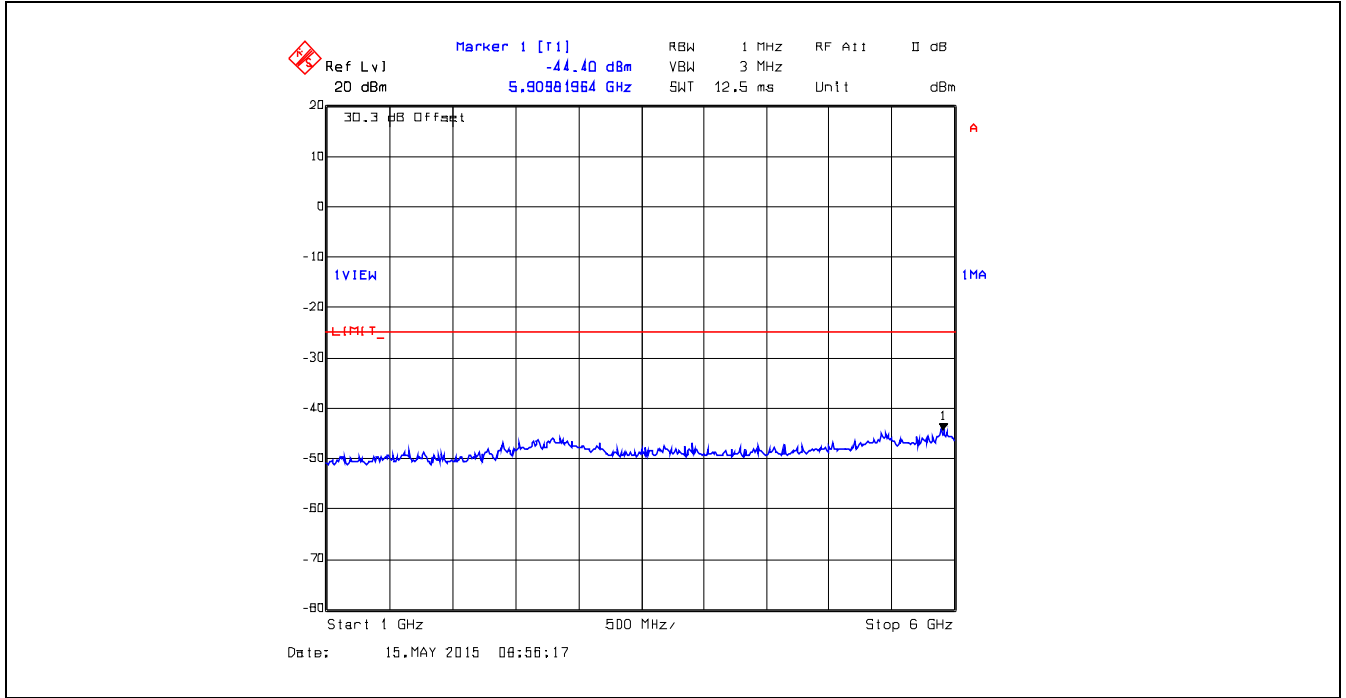

Plot 5.5.4.34. Conducted Transmitter Spurious Emissions, 429.9 MHz, Low Power, 10 MHz – 450 MHz

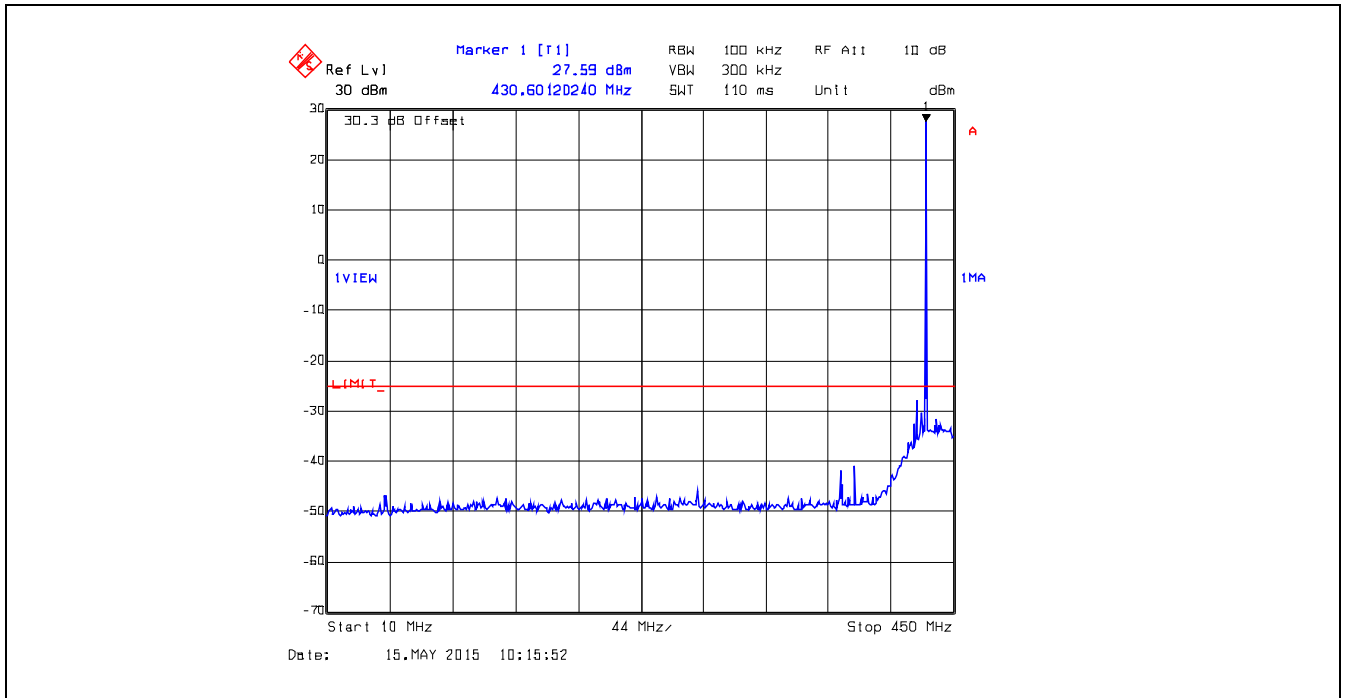

Plot 5.5.4.35. Conducted Transmitter Spurious Emissions, 429.9 MHz, Low Power, 450 MHz – 1 GHz

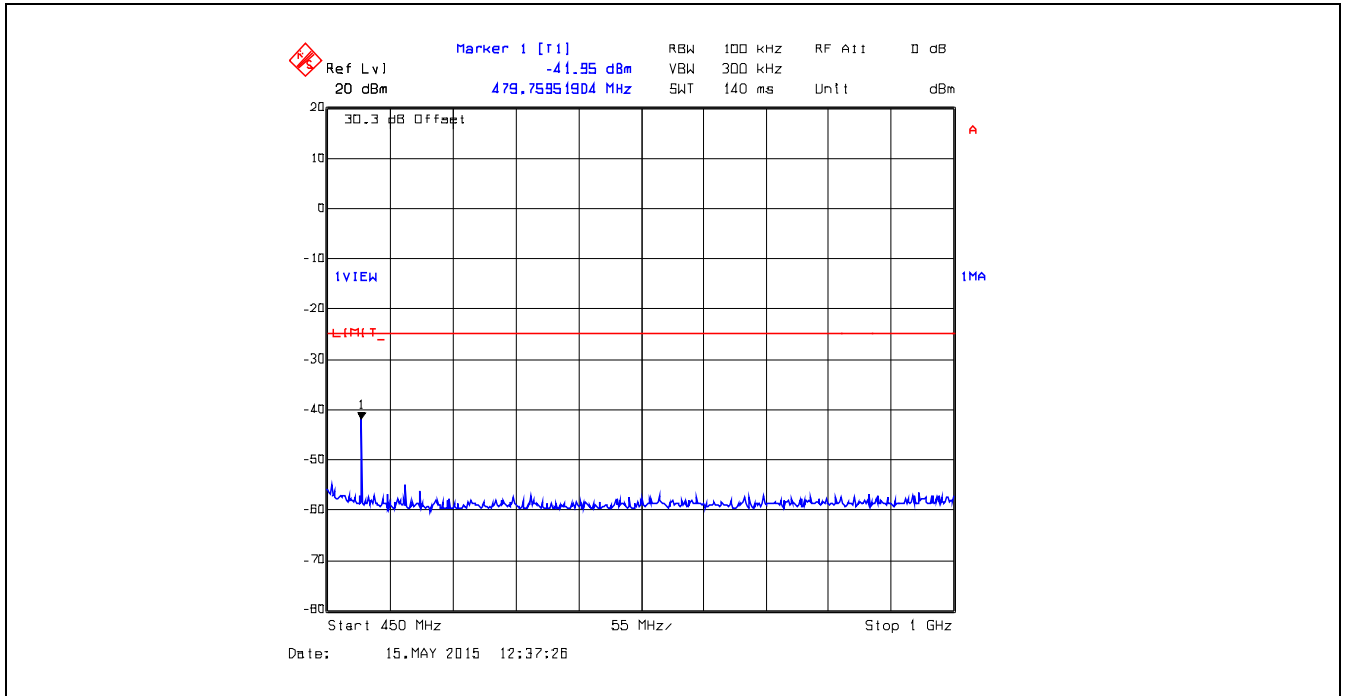

Plot 5.5.4.36. Conducted Transmitter Spurious Emissions, 429.9 MHz, Low Power, 1 GHz – 6 GHz

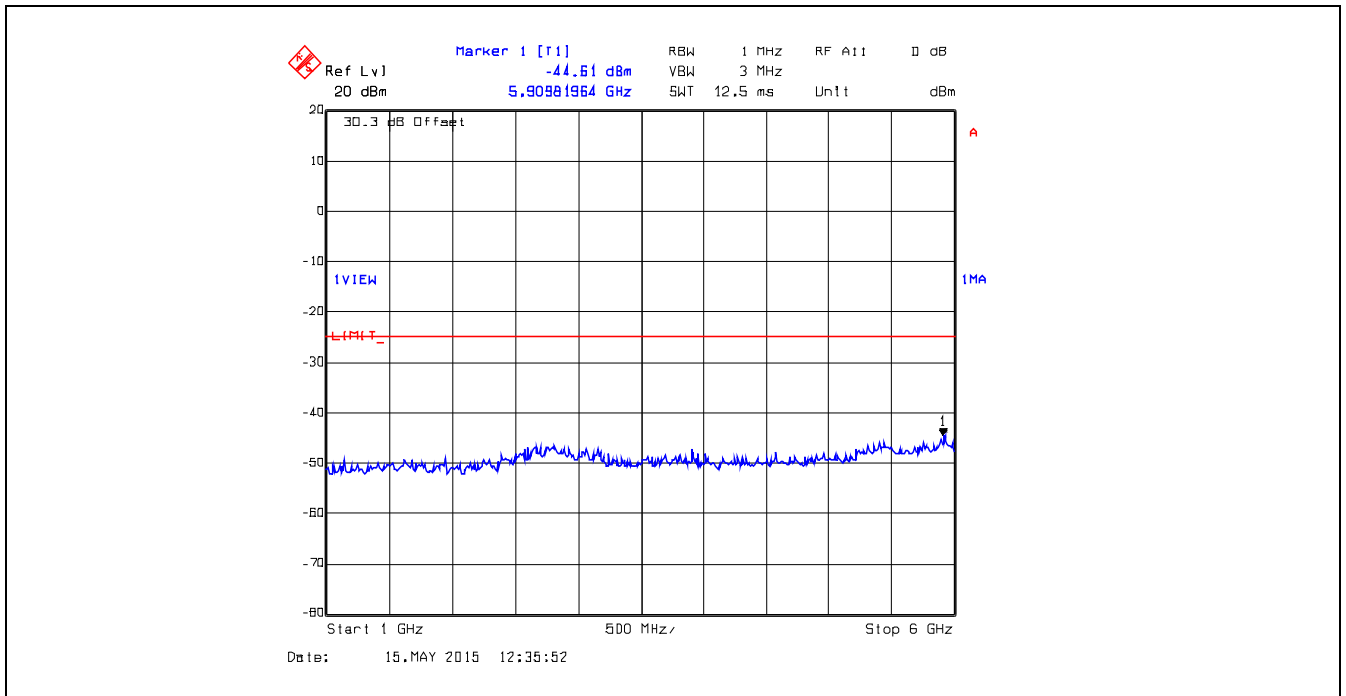

Plot 5.5.4.37. Conducted Transmitter Spurious Emissions, 450.1 MHz, High Power, 10 MHz – 550 MHz

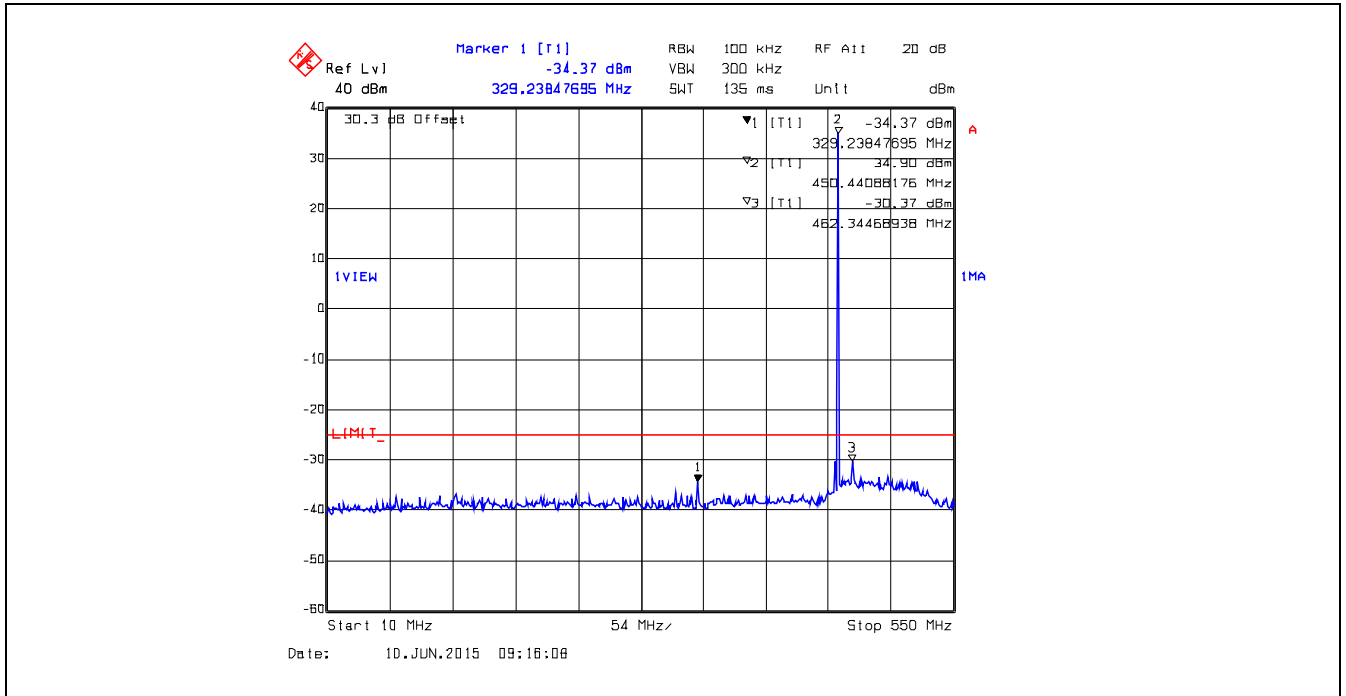

Plot 5.5.4.38. Conducted Transmitter Spurious Emissions, 450.1 MHz, High Power, 550 MHz – 1 GHz

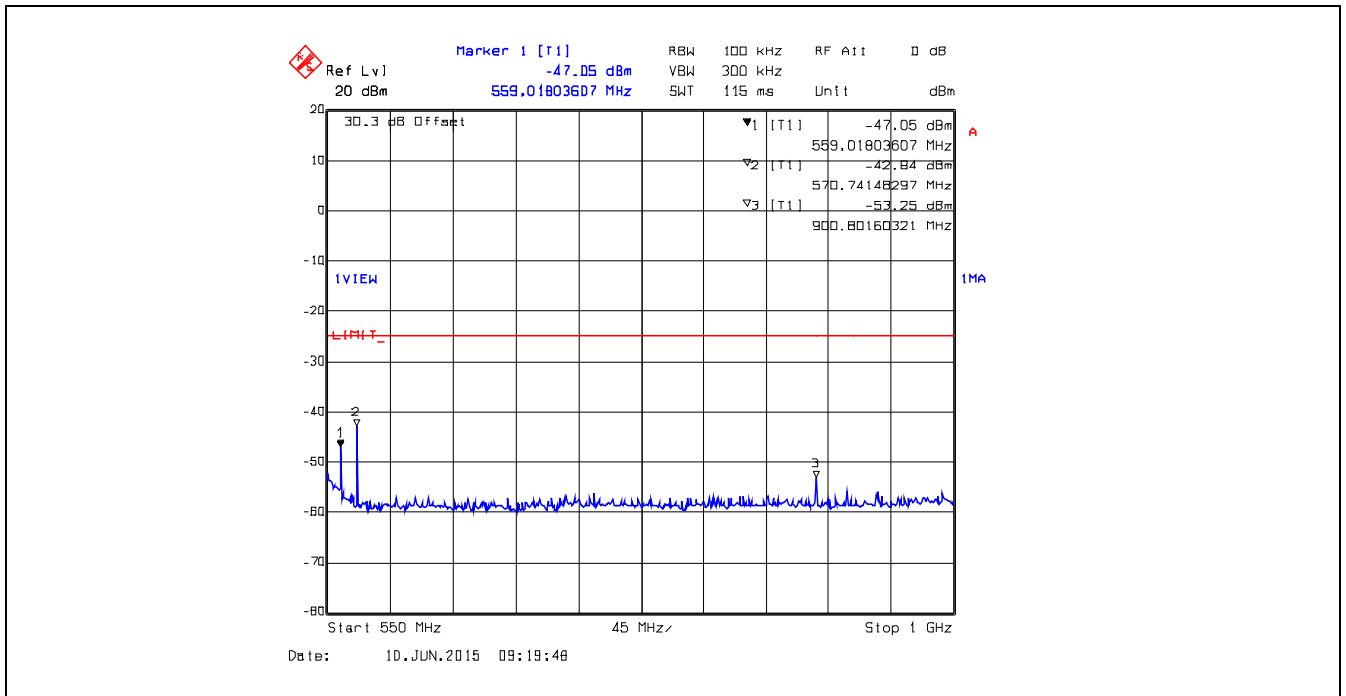

Plot 5.5.4.39. Conducted Transmitter Spurious Emissions, 450.1 MHz, High Power, 1 GHz – 6 GHz

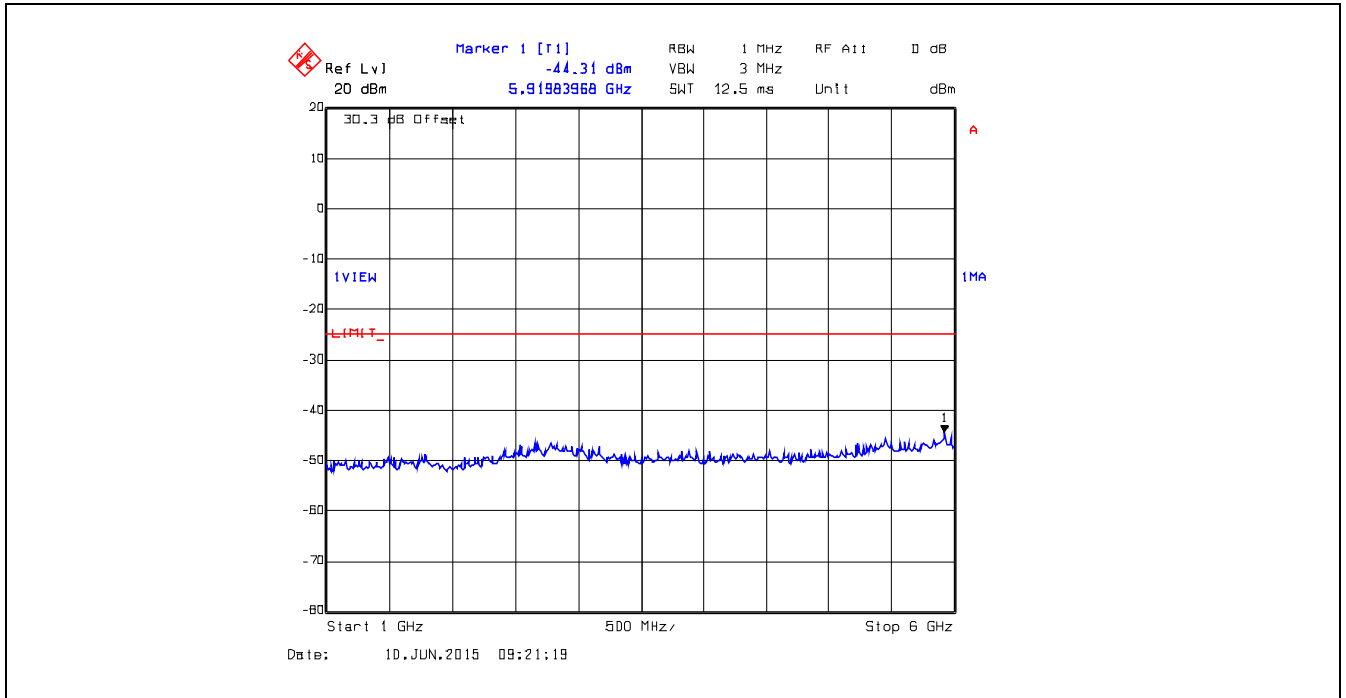

Plot 5.5.4.40. Conducted Transmitter Spurious Emissions, 450.1 MHz, Low Power, 10 MHz – 550 MHz

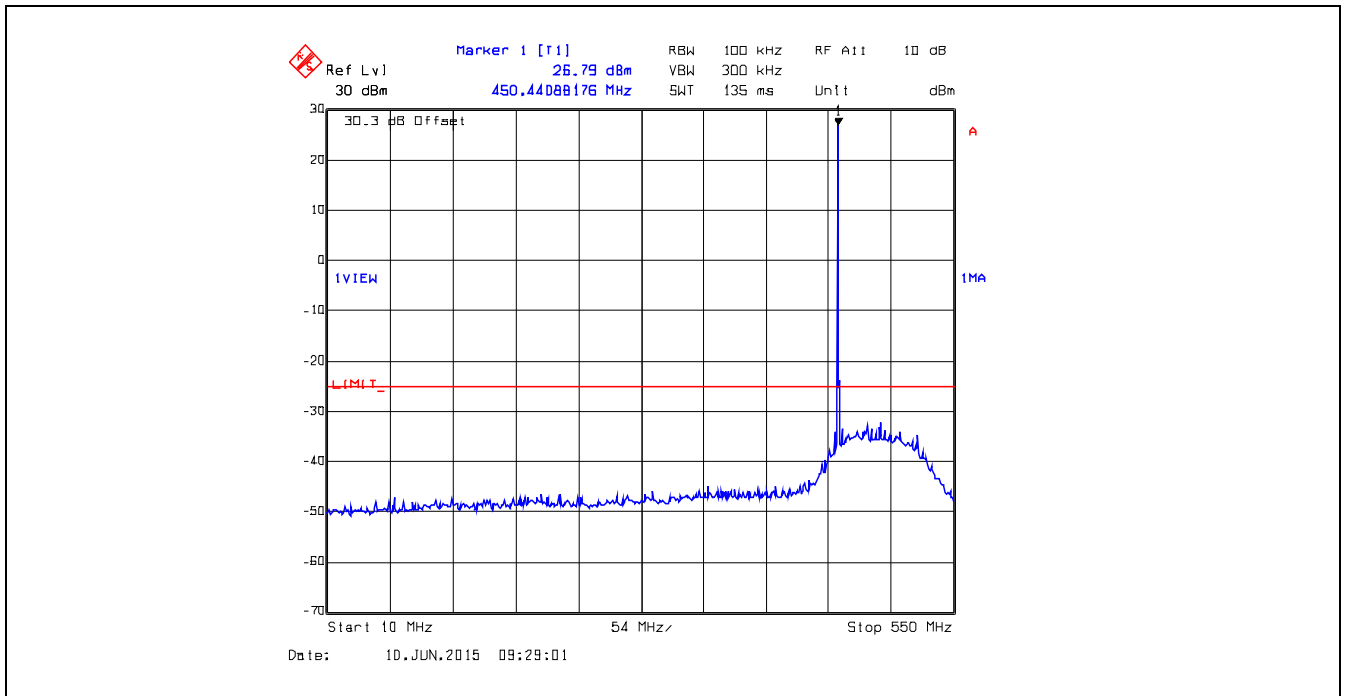

Plot 5.5.4.41. Conducted Transmitter Spurious Emissions, 450.1 MHz, Low Power, 550 MHz – 1 GHz

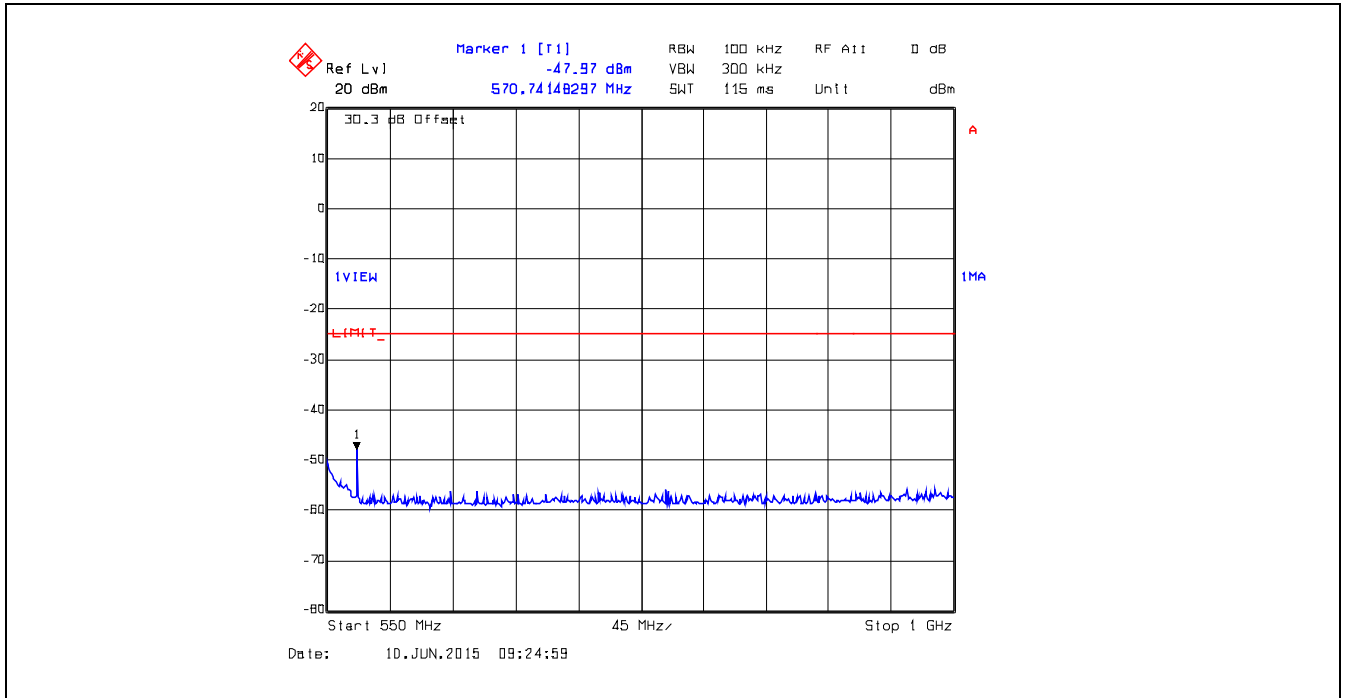

Plot 5.5.4.42. Conducted Transmitter Spurious Emissions, 450.1 MHz, Low Power, 1 GHz – 6 GHz

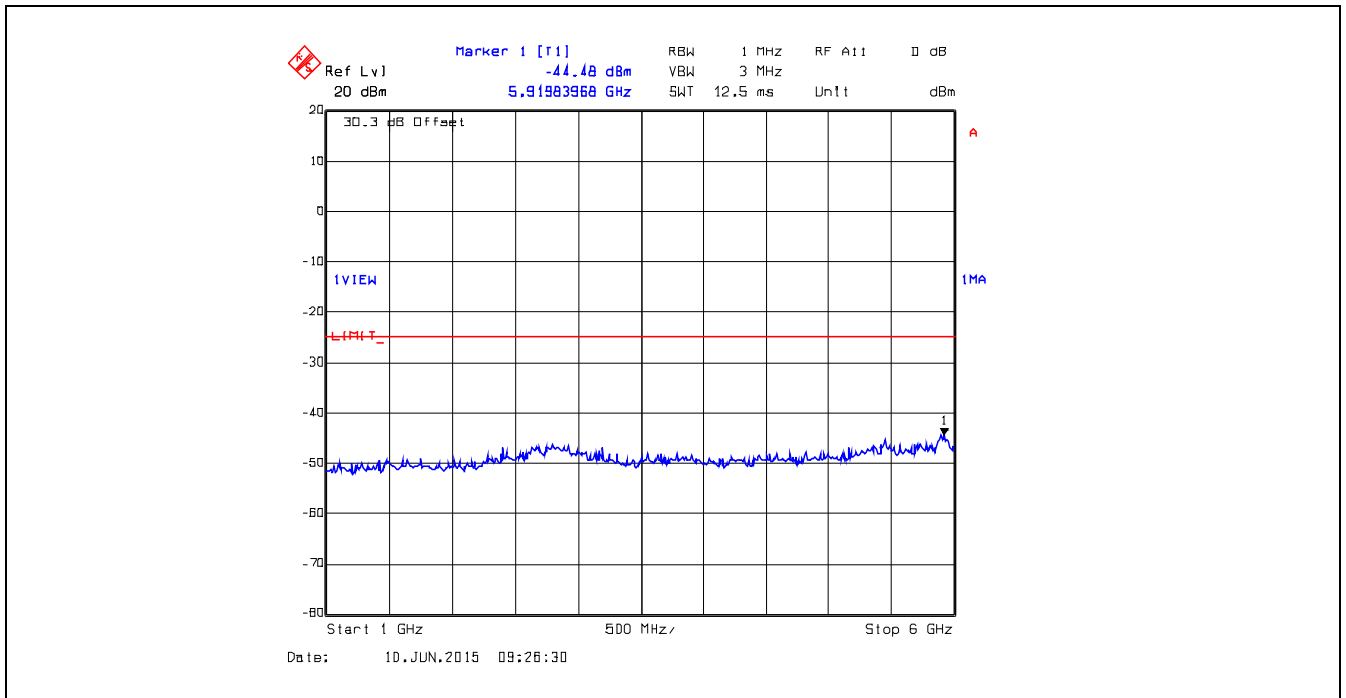

Plot 5.5.4.43. Conducted Transmitter Spurious Emissions, 470.0 MHz, High Power, 10 MHz – 550 MHz

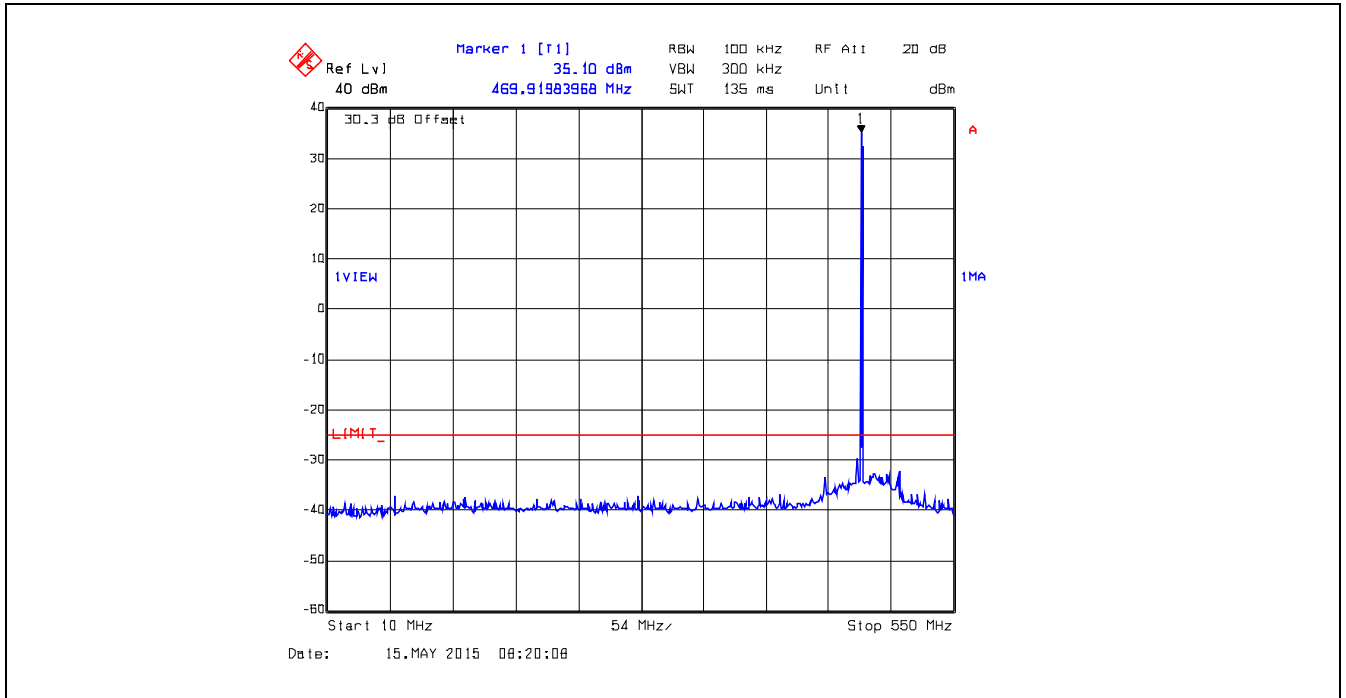

Plot 5.5.4.44. Conducted Transmitter Spurious Emissions, 470.0 MHz, High Power, 550 MHz – 1 GHz

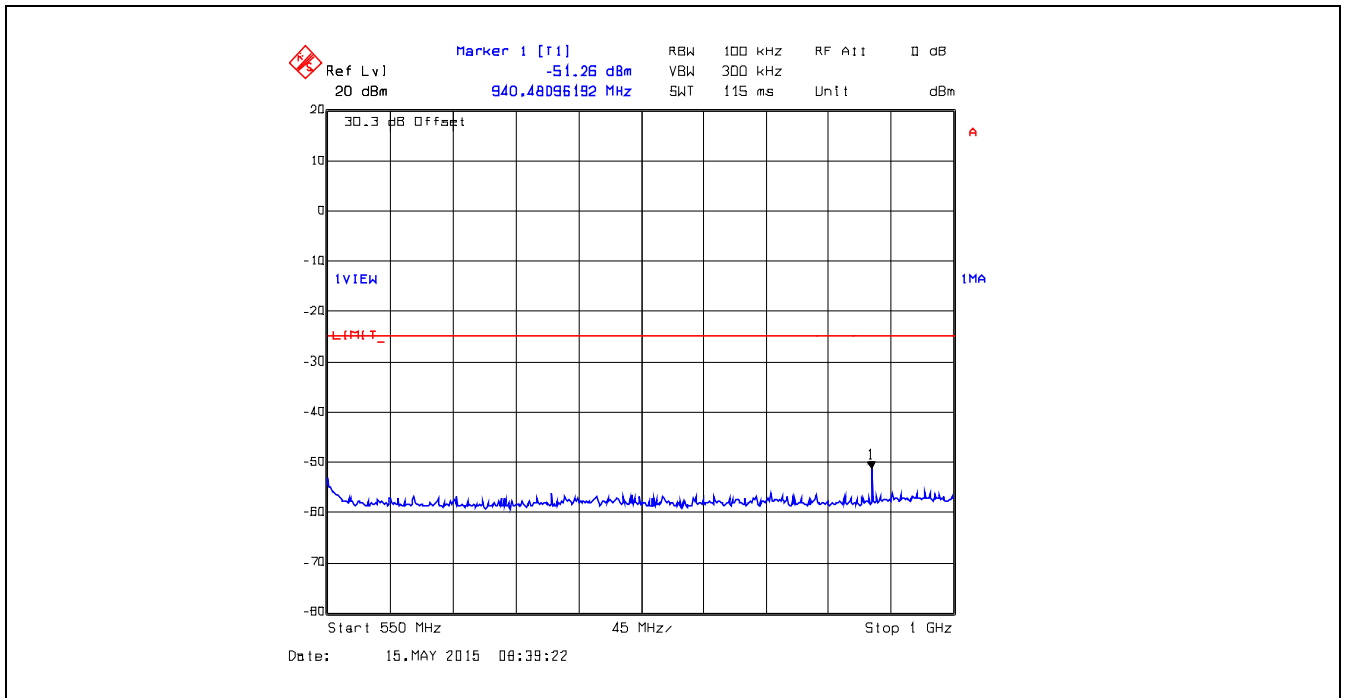

Plot 5.5.4.45. Conducted Transmitter Spurious Emissions, 470.0 MHz, High Power, 1 GHz – 6 GHz

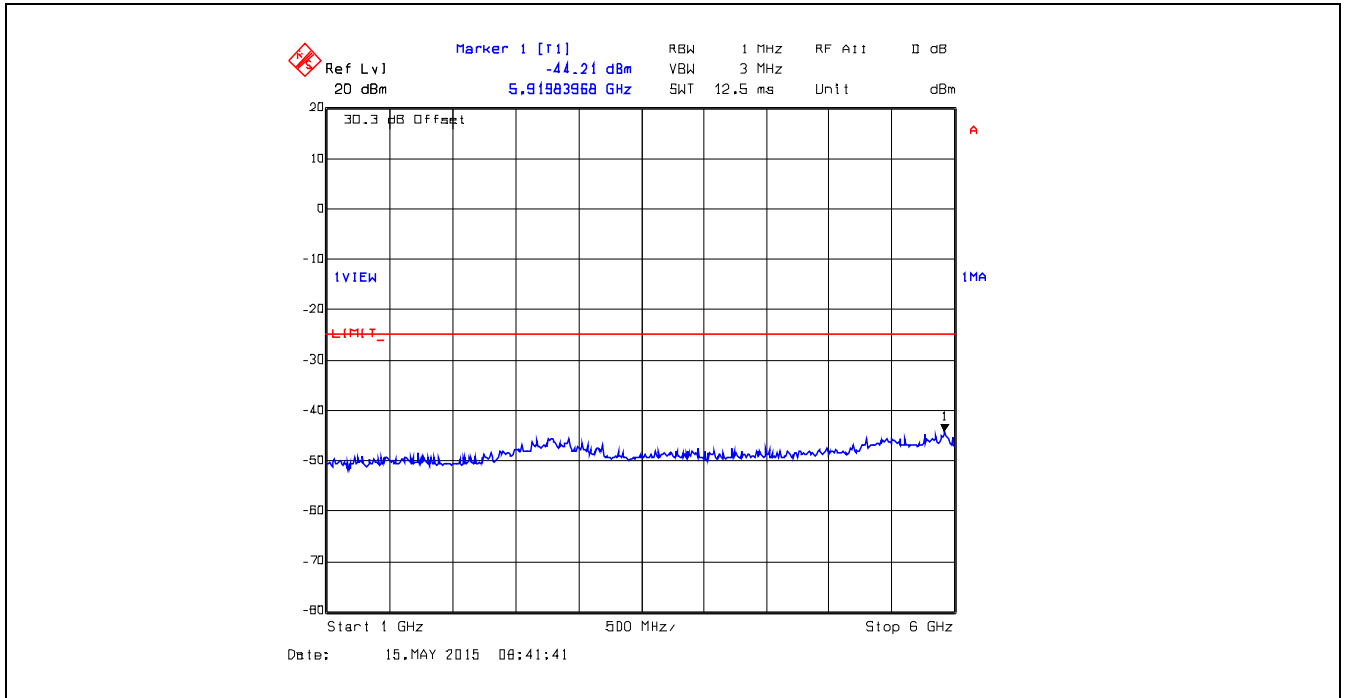

Plot 5.5.4.46. Conducted Transmitter Spurious Emissions, 470.0 MHz, Low Power, 10 MHz – 550 MHz

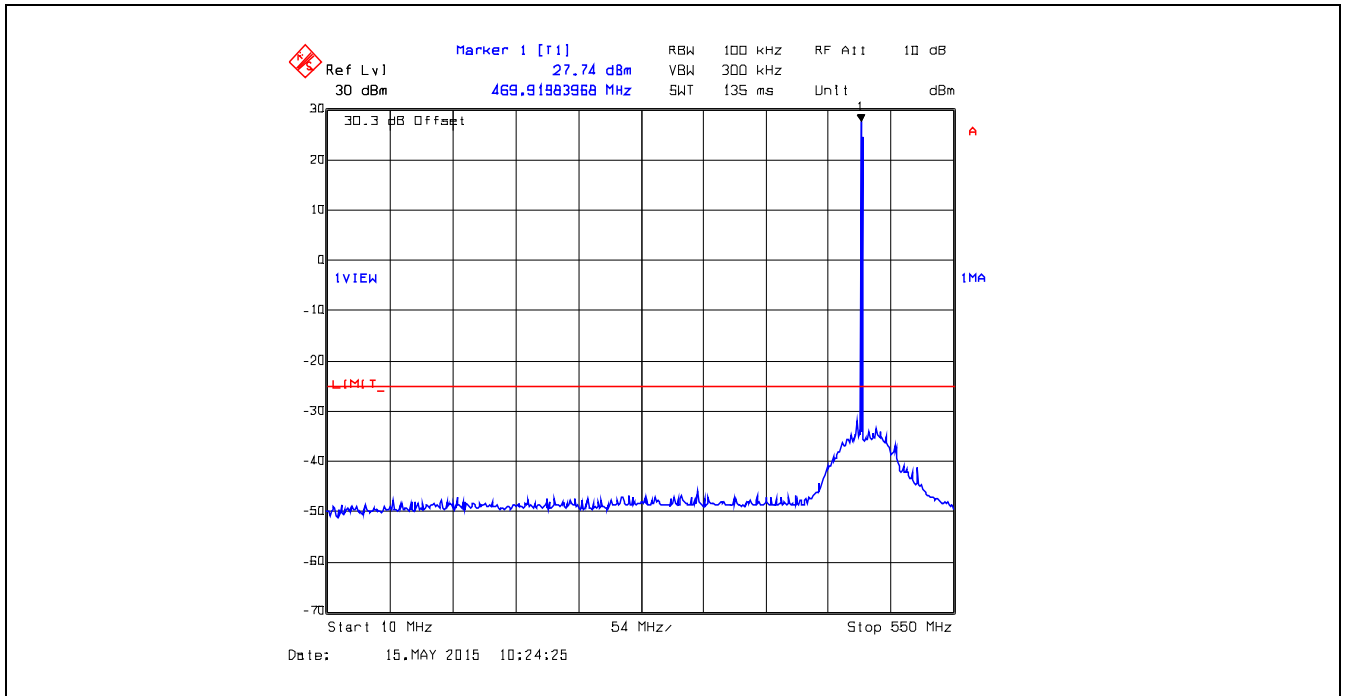

Plot 5.5.4.47. Conducted Transmitter Spurious Emissions, 470.0 MHz, Low Power, 550 MHz – 1 GHz

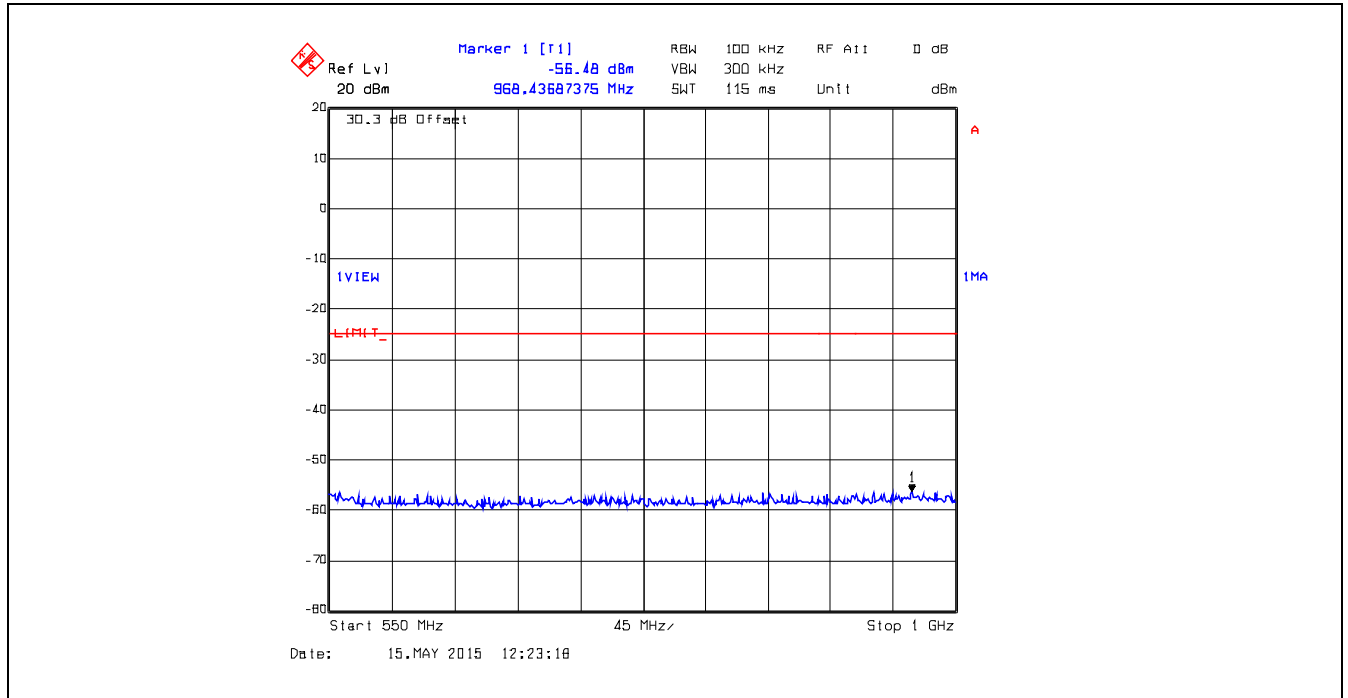

Plot 5.5.4.48. Conducted Transmitter Spurious Emissions, 470.0 MHz, Low Power, 1 GHz – 6 GHz

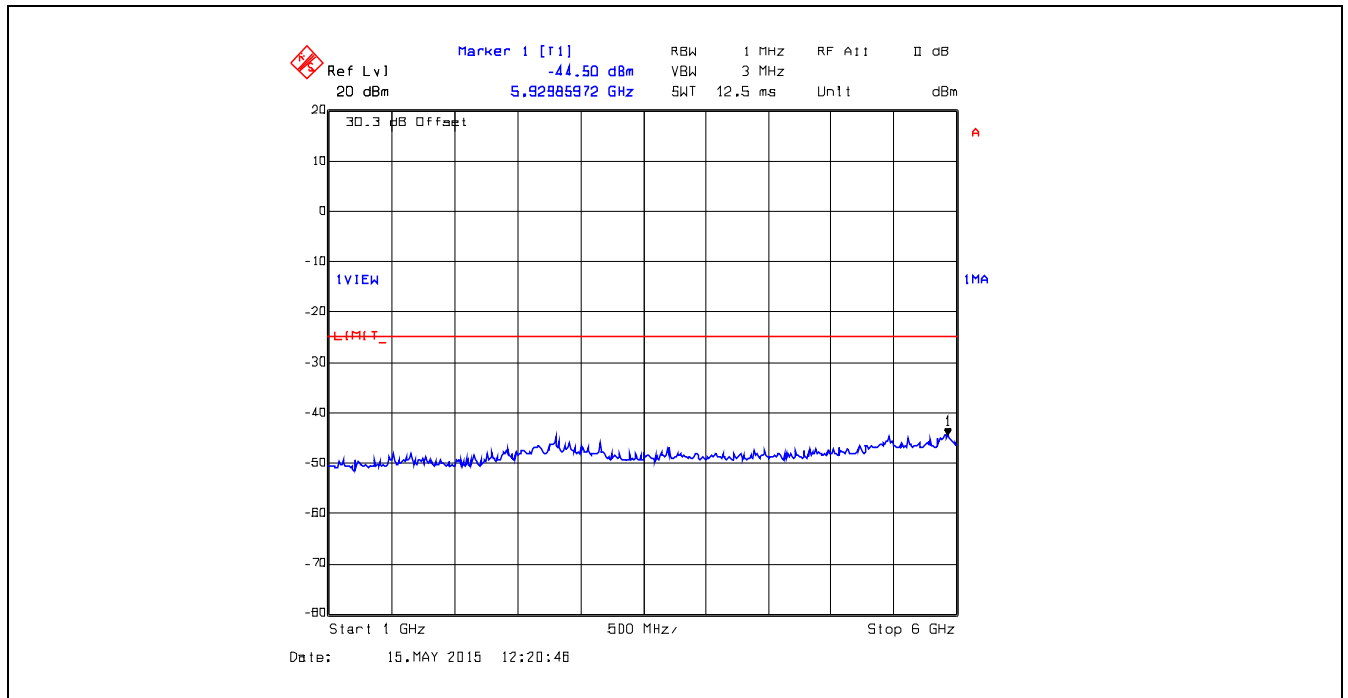

Plot 5.5.4.49. Conducted Transmitter Spurious Emissions, 511.9 MHz, High Power, 10 MHz – 550 MHz

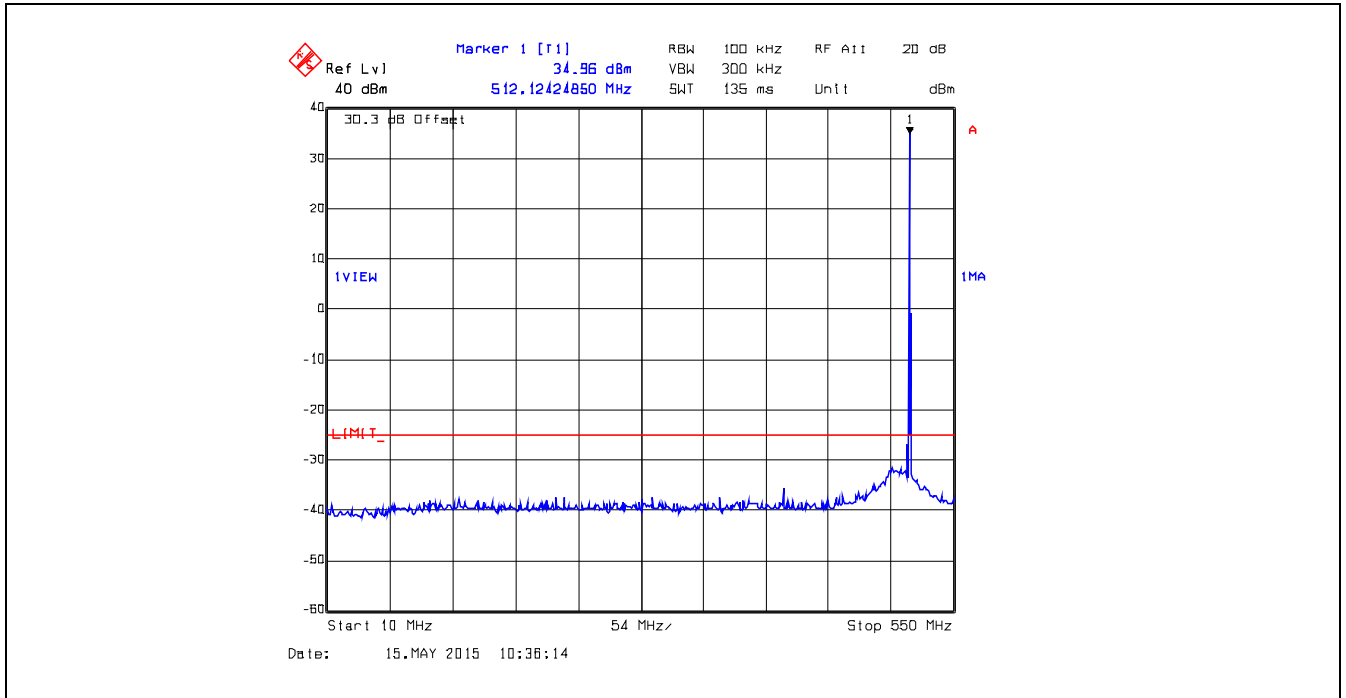

Plot 5.5.4.50. Conducted Transmitter Spurious Emissions, 511.9 MHz, High Power, 550 MHz – 1 GHz

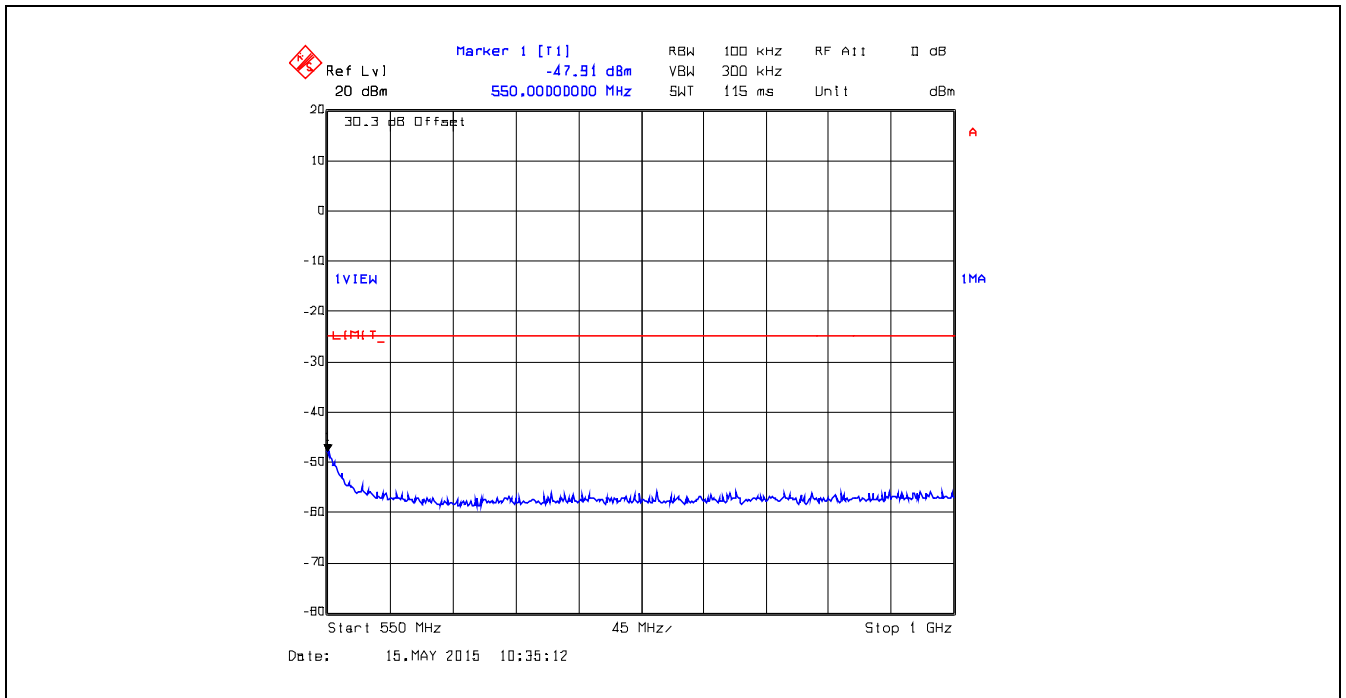

Plot 5.5.4.51. Conducted Transmitter Spurious Emissions, 511.9 MHz, High Power, 1 GHz – 6 GHz

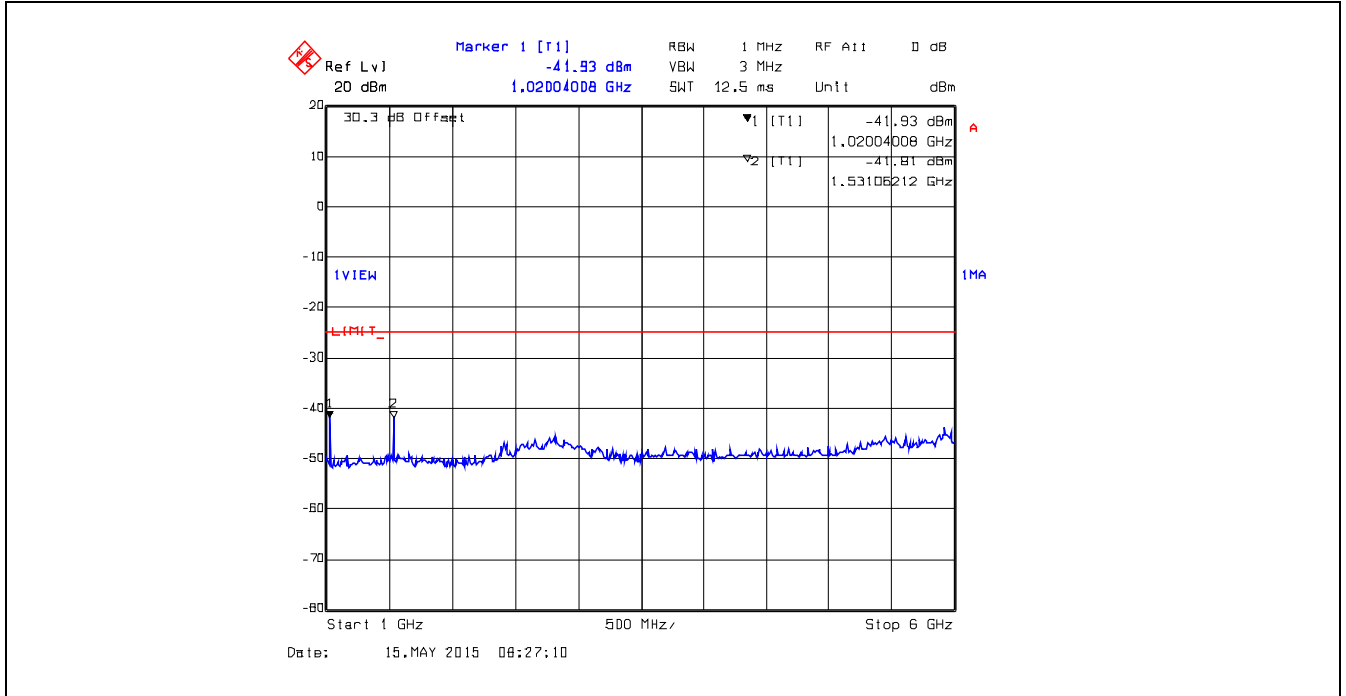

Plot 5.5.4.52. Conducted Transmitter Spurious Emissions, 511.9 MHz, Low Power, 10 MHz – 550 MHz

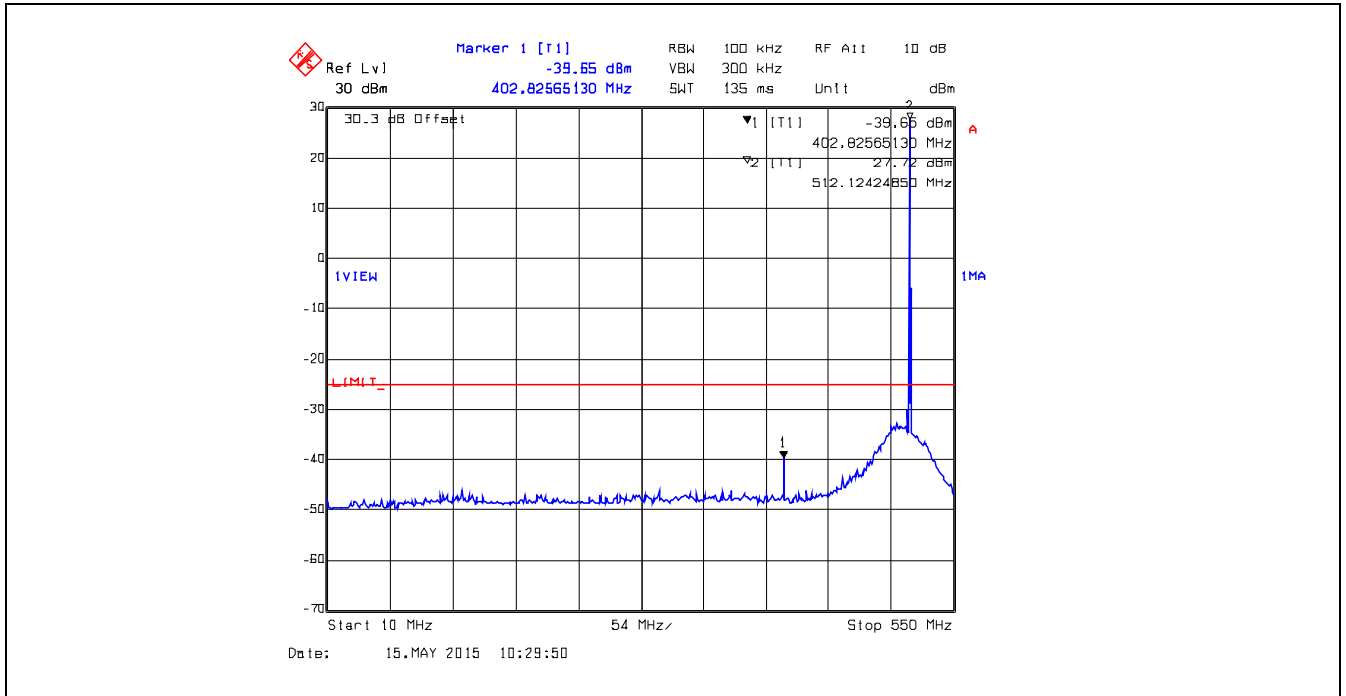

Plot 5.5.4.53. Conducted Transmitter Spurious Emissions, 511.9 MHz, Low Power, 550 MHz – 1 GHz

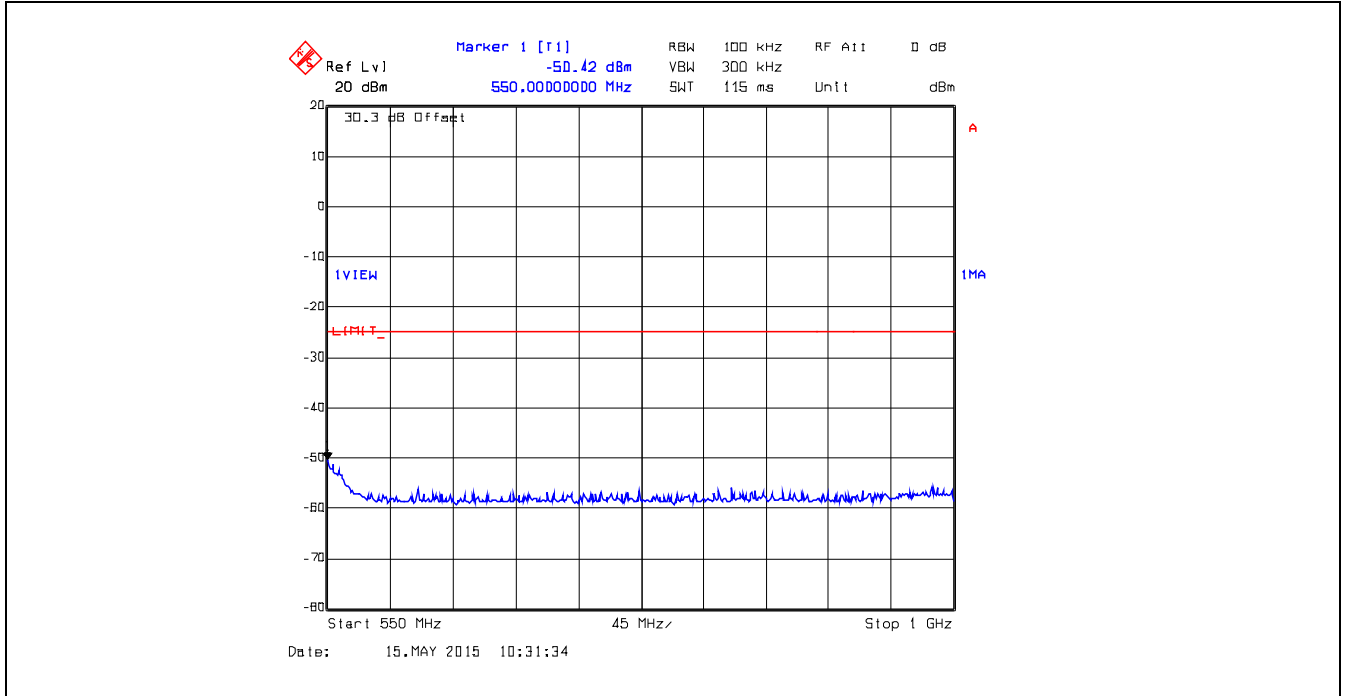

Plot 5.5.4.54. Conducted Transmitter Spurious Emissions, 511.9 MHz, Low Power, 1 GHz – 6 GHz

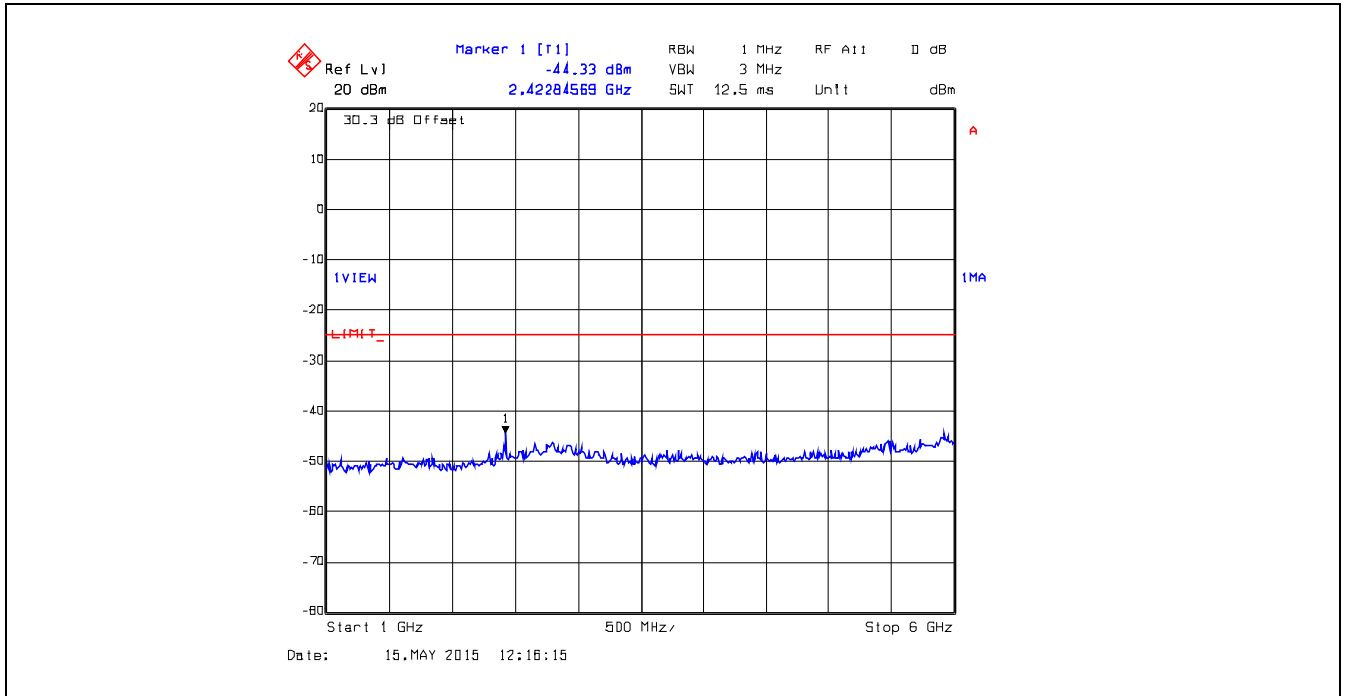

5.6. TRANSMITTER SPURIOUS/HARMONIC RADIATED EMISSIONS [§§ 2.1053, 2.1057 & 90.210]

5.6.1. Limits

Emissions shall be attenuated below the mean output power of the transmitter as follows:

FCC Rules	Attenuation Limit (dBc)
§ 90.210(b)	At least $43 + 10 \log (P)$ dB
§ 90.210(c)	At least $43 + 10 \log (P)$ dB
§ 90.210(d)	At least $50 + 10 \log (P)$ dB or 70 dB, whichever is the lesser attenuation.
§ 90.210(e)	At least $55 + 10 \log (P)$ or 65 dB, whichever is the lesser attenuation.

5.6.2. Method of Measurements

See substitution test method specified in Section 8.2 of this report

5.6.3. Test Arrangement

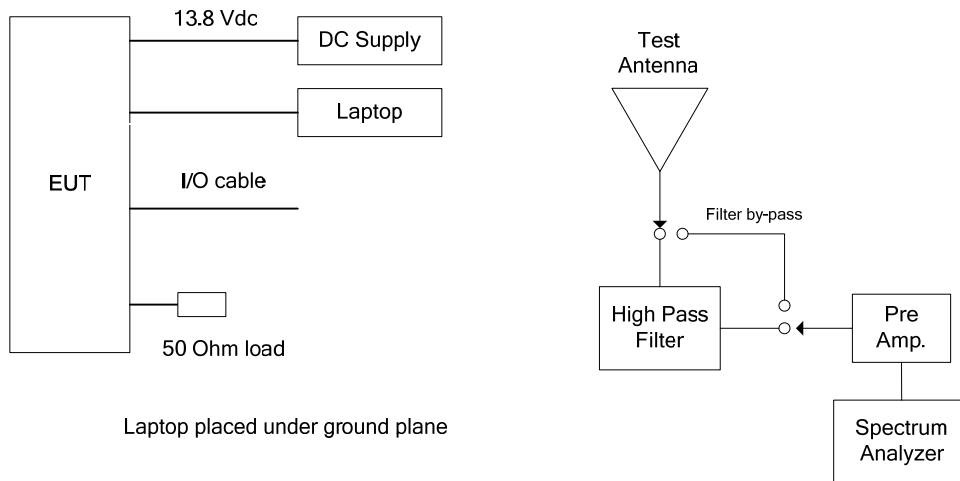

5.6.4. Test Data

Remarks:

- Exploratory tests were conducted with modulations in the range of typical modes of operation to identify the worst-case modulation. There were no discernable differences detected. The digital mode, operating at 6.25 kHz channel spacing was used to represent the worst-case test configuration for the final measurement.
- The radiated emissions were performed with high power setting at 3 m distance to represent the worst-case test configuration.
- The emissions were scanned from 30 MHz to 10th harmonics (6 GHz); all spurious emissions that are in excess of 20dB below the specified limit shall be recorded.

Test Frequency (MHz): 380.1						
Limit (dBm): -25						
Frequency (MHz)	E-Field (dBµV/m)	EMI Detector (Peak/QP)	Antenna Polarization (H/V)	ERP measured (dBm)	Limit (dBm)	Margin (dB)
760.20	67.16	Peak	V	-28.91	-25	-3.9
760.20	68.22	Peak	H	-29.79	-25	-4.8

Test Frequency (MHz): 390.0						
Limit (dBm): -25						
Frequency (MHz)	E-Field (dBµV/m)	EMI Detector (Peak/QP)	Antenna Polarization (H/V)	ERP measured (dBm)	Limit (dBm)	Margin (dB)
780.00	69.16	Peak	V	-26.91	-25	-1.9
780.00	71.25	Peak	H	-26.76	-25	-1.8

Test Frequency (MHz): 399.9						
Limit (dBm): -25						
Frequency (MHz)	E-Field (dBµV/m)	EMI Detector (Peak/QP)	Antenna Polarization (H/V)	ERP measured (dBm)	Limit (dBm)	Margin (dB)
799.80	66.80	Peak	V	-29.27	-25	-4.3
799.80	71.16	Peak	H	-26.85	-25	-1.9

Test Frequency (MHz): 406.2						
Limit (dBm): -25						
Frequency (MHz)	E-Field (dBµV/m)	EMI Detector (Peak/QP)	Antenna Polarization (H/V)	ERP measured (dBm)	Limit (dBm)	Margin (dB)
812.40	63.82	Peak	H	-34.19	-25	-9.2

Test Frequency (MHz): 415.0						
Limit (dBm): -25						
Frequency (MHz)	E-Field (dBµV/m)	EMI Detector (Peak/QP)	Antenna Polarization (H/V)	ERP measured (dBm)	Limit (dBm)	Margin (dB)
830.00	59.80	Peak	V	-36.27	-25	-11.3
830.00	65.87	Peak	H	-32.14	-25	-7.1

Test Frequency (MHz): 429.9						
Limit (dBm): -25						
Frequency (MHz)	E-Field (dBµV/m)	EMI Detector (Peak/QP)	Antenna Polarization (H/V)	ERP measured (dBm)	Limit (dBm)	Margin (dB)
859.80	51.23	Peak	V	-44.84	-25	-19.8
859.80	56.60	Peak	H	-41.41	-25	-16.4

Test Frequency (MHz): 450.1						
Limit (dBm): -25						
Frequency (MHz)	E-Field (dBµV/m)	EMI Detector (Peak/QP)	Antenna Polarization (H/V)	ERP measured (dBm)	Limit (dBm)	Margin (dB)
30 - 6000	*	Peak	H/V	*	-25	*

* All harmonics and spurious emissions are more than 20 dB below the specified attenuation limit.

Test Frequency (MHz): 470.0						
Limit (dBm): -25						
Frequency (MHz)	E-Field (dBµV/m)	EMI Detector (Peak/QP)	Antenna Polarization (H/V)	ERP measured (dBm)	Limit (dBm)	Margin (dB)
30 - 6000	*	Peak	H/V	*	-25	*

* All harmonics and spurious emissions are more than 20 dB below the specified attenuation limit.

5.7. FREQUENCY STABILITY [§§ 2.1055 & 90.213]

5.7.1. Limits

§90.213 Frequency stability

Minimum Frequency Stability (ppm)			
Frequency range (MHz)	Fixed and base stations	Mobile stations	
		Over 2 watts output power	2 watts or less output power
421-512	¹ 3 ⁴ 2.5	² 5	² 5

¹In the 421-512 MHz band, fixed and base stations with a 12.5 kHz channel bandwidth must have a frequency stability of 1.5 ppm. Fixed and base stations with a 6.25 kHz channel bandwidth must have a frequency stability of 0.5 ppm.

²In the 421-512 MHz band, mobile stations designed to operate with a 12.5 kHz channel bandwidth must have a frequency stability of 2.5 ppm. Mobile stations designed to operate with a 6.25 kHz channel bandwidth must have a frequency stability of 1.0 ppm.

³Paging transmitters operating on paging-only frequencies must operate with frequency stability of 5 ppm in the 150-174 MHz band and 2.5 ppm in the 421-512 MHz band.

⁴Control stations may operate with the frequency tolerance specified for associated mobile frequencies.

5.7.2. Method of Measurements

Refer to Section 8.3 of this report for measurement details.

5.7.3. Test Arrangement

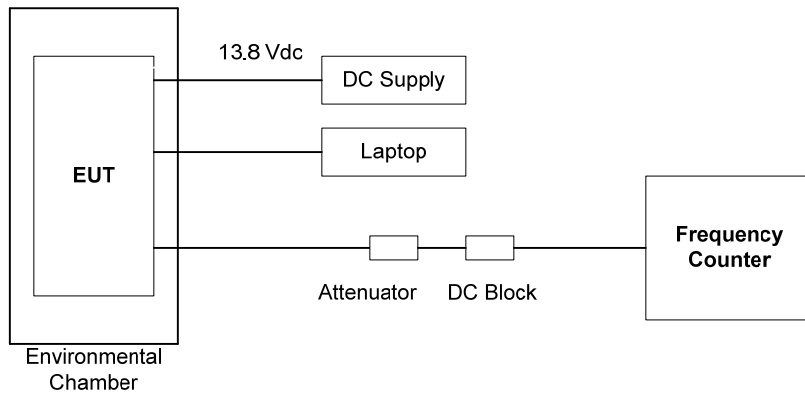

5.7.4. Test Data

Test Frequency:		406.2 MHz	
Full Power Level:		3 W	
Frequency Tolerance Limit:		± 1 ppm or ± 406.2 Hz	
Max. Frequency Tolerance Measured:		-78 Hz or 0.19 ppm	
Input Voltage Rating:		13.8 VDC (nominal)	
Ambient Temperature (°C)	Frequency Drift (Hz)		
	Supply Voltage (Nominal) 13.8 VDC	Supply Voltage (85% of Nominal) 11.73 VDC	Supply Voltage (115% of Nominal) 15.87 VDC
-30	-78	--	--
-20	-12	--	--
-10	-22	--	--
0	-48	--	--
+10	-67	--	--
+20	-52	-50	-50
+30	-41	--	--
+40	-33	--	--
+50	-52	--	--
+60	23	--	--

5.8. TRANSIENT FREQUENCY BEHAVIOR [§ 90.214]

5.8.1. Limits

Transient frequencies must be within the maximum frequency difference limits during the time intervals indicated:

Time intervals ^{1, 2}	Maximum frequency difference ³	All equipment	
		150 to 174 MHz	421 to 512MHz
Transient Frequency Behavior for Equipment Designed to Operate on 25 KHz Channels			
t ₁ ⁴	± 25.0 KHz	5.0 ms	10.0 ms
t ₂	± 12.5 KHz	20.0 ms	25.0 ms
t ₃ ⁴	± 25.0 KHz	5.0 ms	10.0 ms
Transient Frequency Behavior for Equipment Designed to Operate on 12.5 KHz Channels			
t ₁ ⁴	± 12.5 KHz	5.0 ms	10.0 ms
t ₂	± 6.25 KHz	20.0 ms	25.0 ms
t ₃ ⁴	± 12.5 KHz	5.0 ms	10.0 ms
Transient Frequency Behavior for Equipment Designed to Operate on 6.25 KHz Channels			
t ₁ ⁴	±6.25 KHz	5.0 ms	10.0 ms
t ₂	±3.125 KHz	20.0 ms	25.0 ms
t ₃ ⁴	±6.25 KHz	5.0 ms	10.0 ms

- t_{on} is the instant when a 1 kHz test signal is completely suppressed, including any capture time due to phasing.
 t₁ is the time period immediately following t_{on}.
 t₂ is the time period immediately following t₁.
 t₃ is the time period from the instant when the transmitter is turned off until t_{off}.
 t_{off} is the instant when the 1 kHz test signal starts to rise.
- During the time from the end of t₂ to the beginning of t₃, the frequency difference must not exceed the limits specified in § 90.213.
- Difference between the actual transmitter frequency and the assigned transmitter frequency.
- If the transmitter carrier output power rating is 6 Watts or less, the frequency difference during this time period may exceed the maximum frequency difference for this time period.

5.8.2. Method of Measurements

ANSI/TIA/EIA-603-D-2010, Section 2.2.19.

5.8.3. Test Arrangement

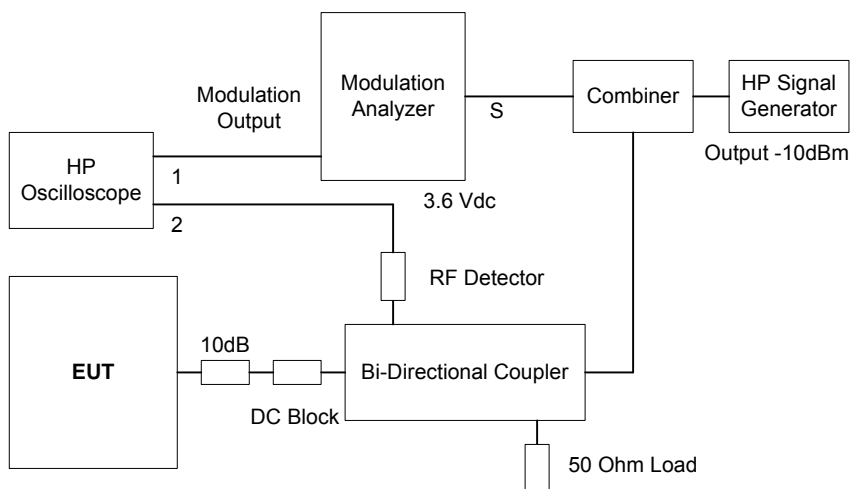

5.8.4. Test Data

Plot 5.8.4.1. Transient Frequency Behavior for 25 kHz Channel Spacing
406.2 MHz, High Power Setting, Switch on condition t_{on} , t_1 , and t_2

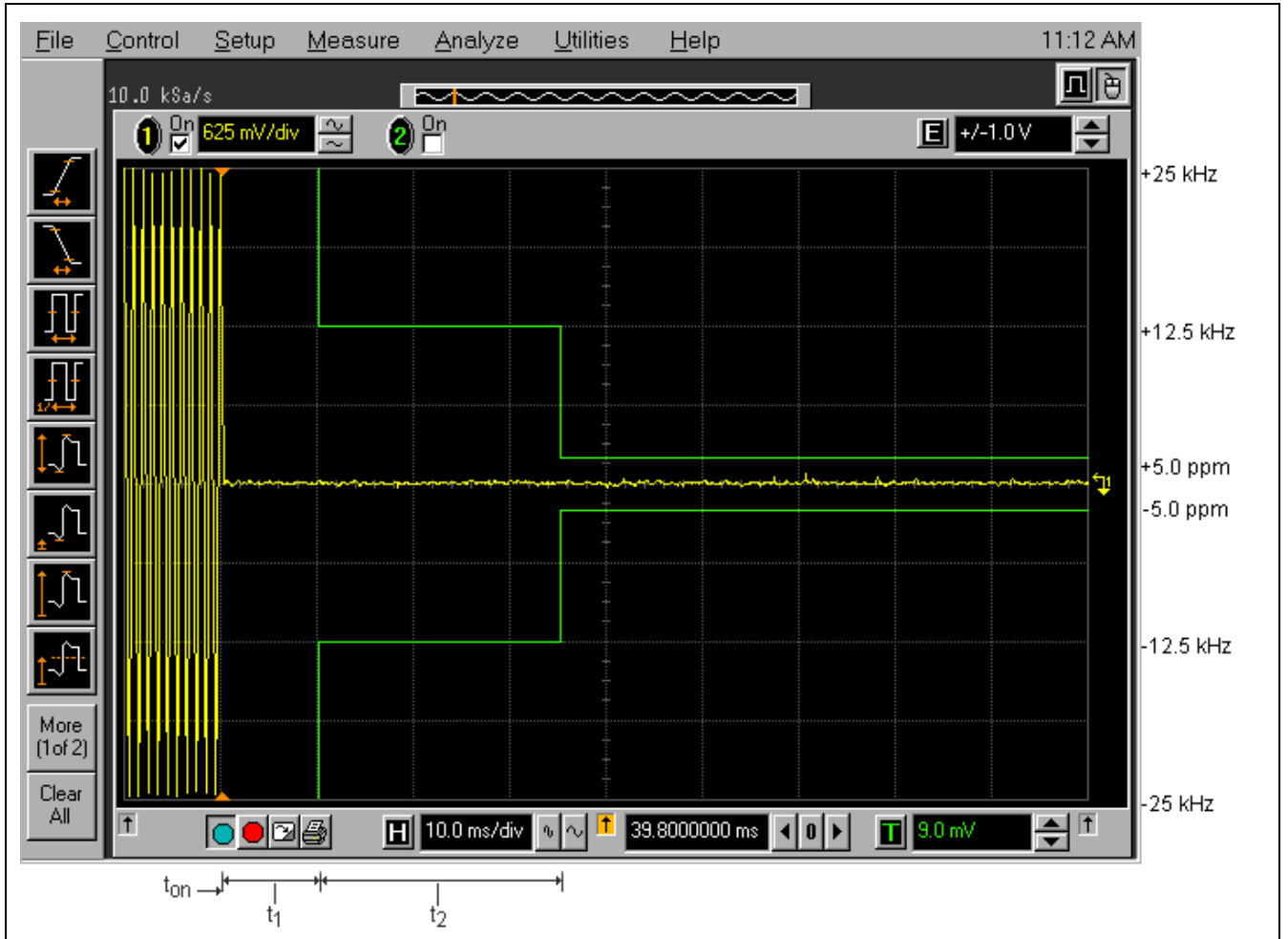

Plot 5.8.4.2. Transient Frequency Behavior for 25 kHz Channel Spacing
406.2 MHz, High Power Setting, Switch off condition t_3 , t_{off}

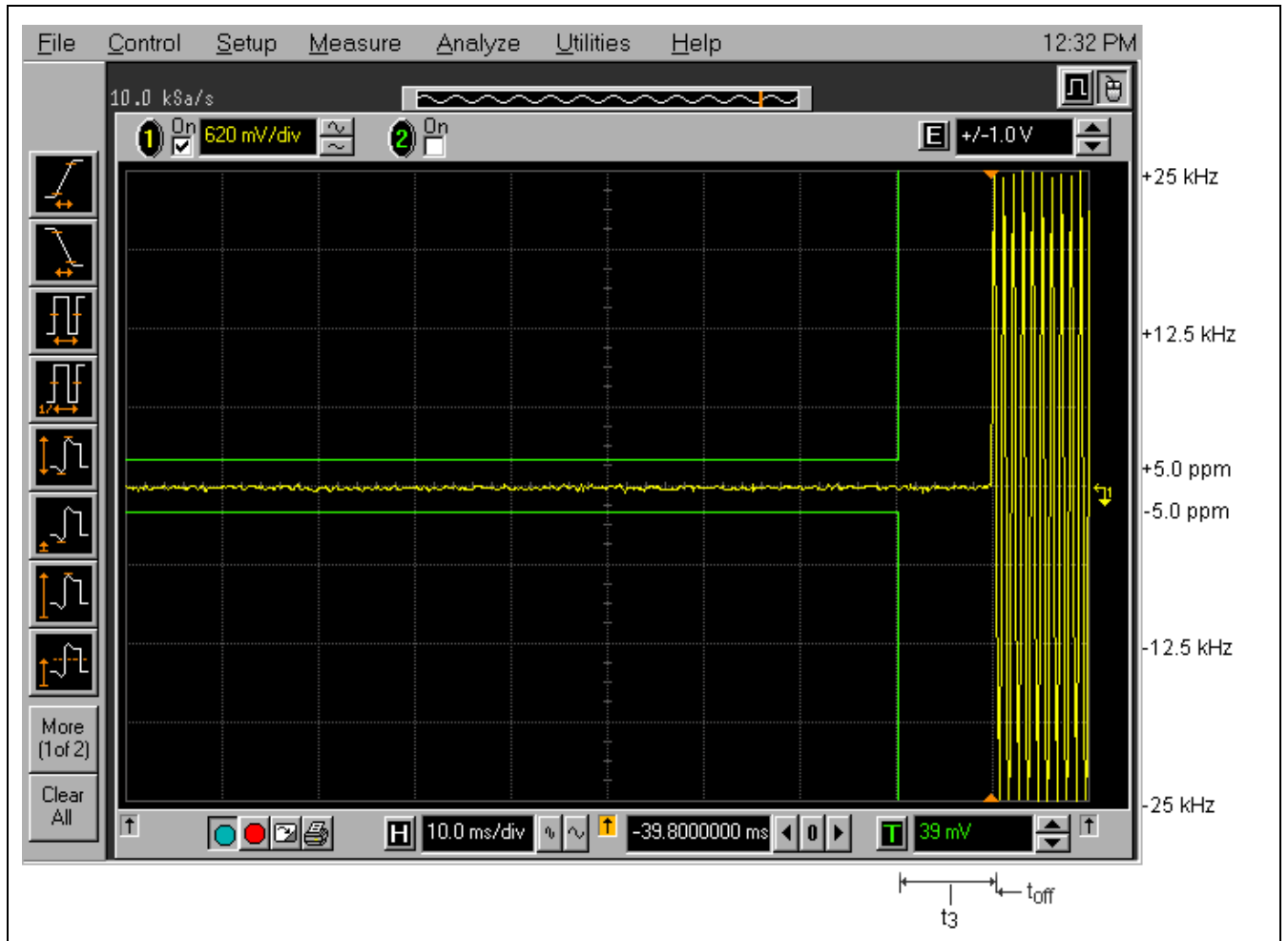

Plot 5.8.4.3. Transient Frequency Behavior for 12.5 kHz Channel Spacing
406.2 MHz, High Power Setting, Switch on condition t_{on} , t_1 , and t_2

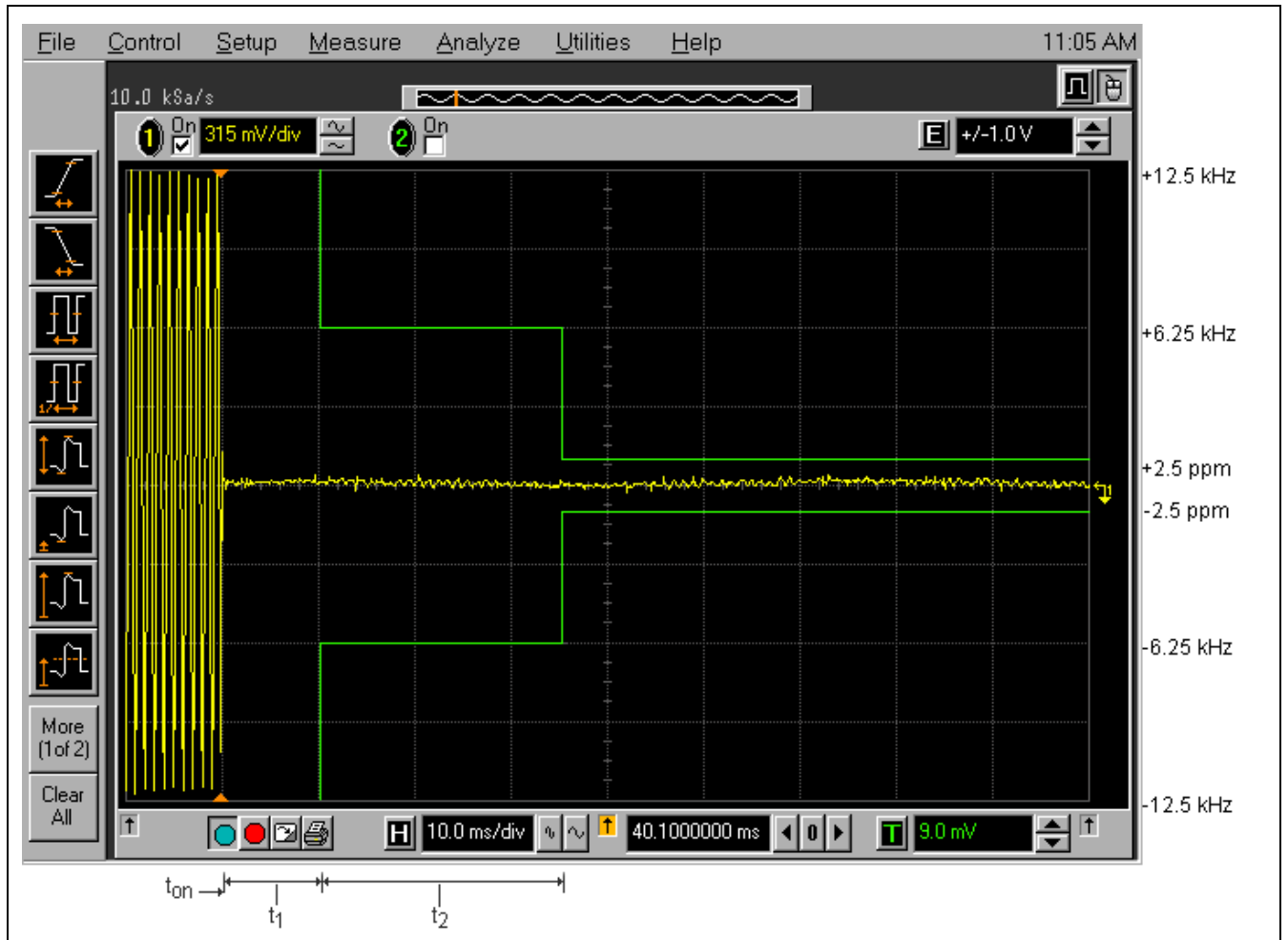

Plot 5.8.4.4. Transient Frequency Behavior for 12.5 kHz Channel Spacing
406.2 MHz, High Power Setting, Switch off condition t_3 , t_{off}

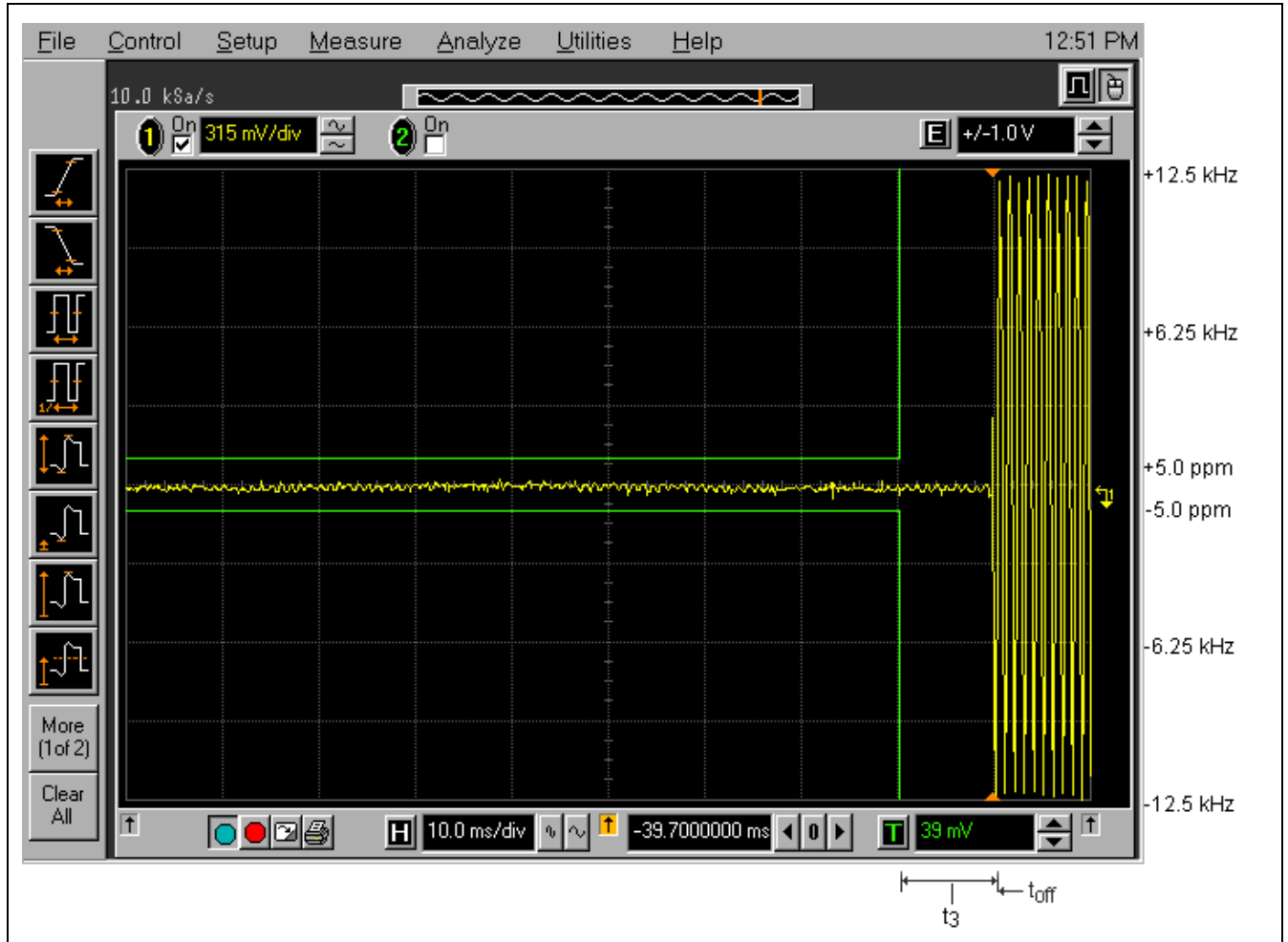

Plot 5.8.4.5. Transient Frequency Behavior for 6.25 kHz Channel Spacing
406.2 MHz, High Power Setting, Switch on condition t_{on} , t_1 , and t_2

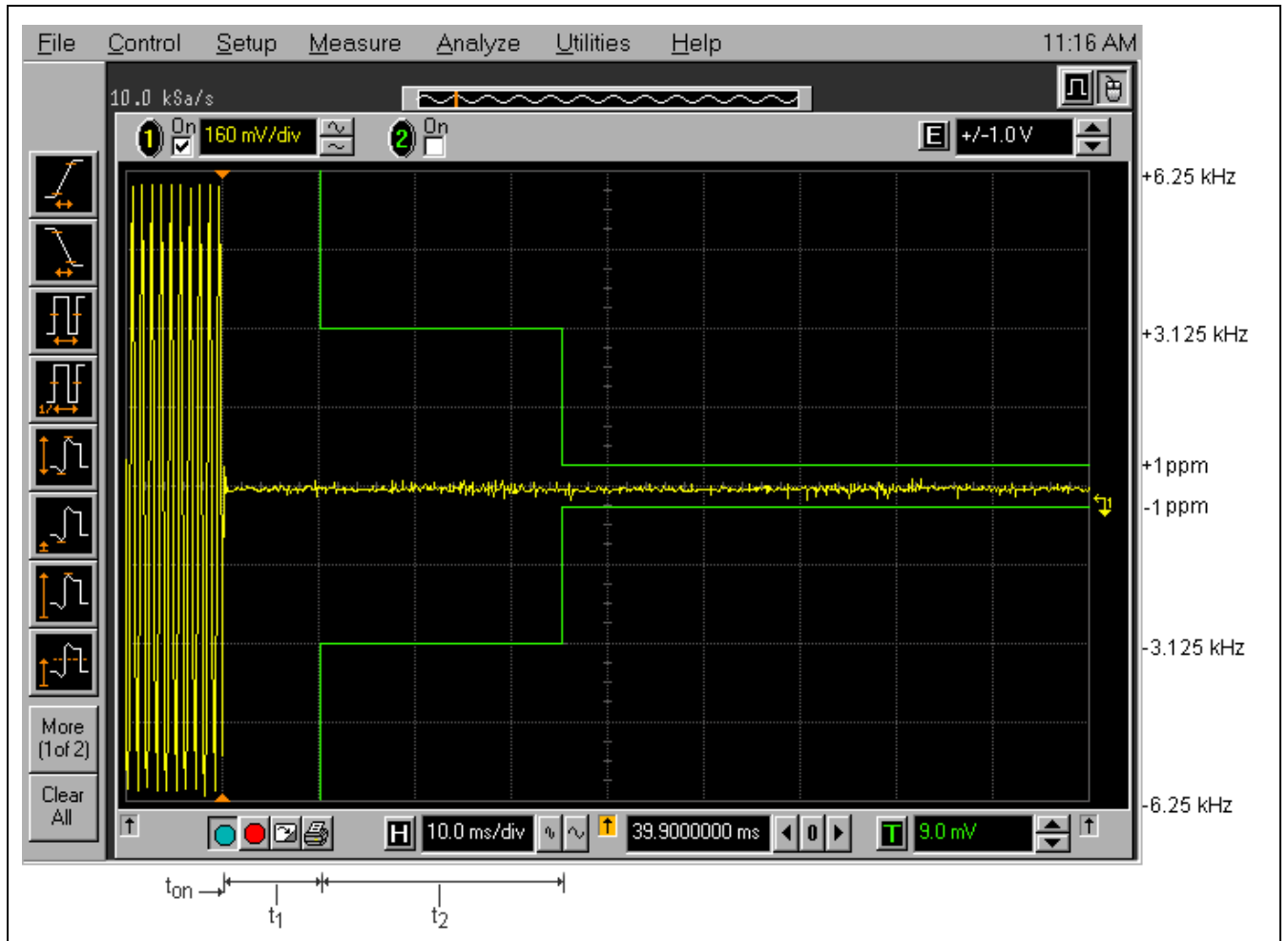

Plot 5.8.4.6. Transient Frequency Behavior for 6.25 kHz Channel Spacing
406.2 MHz, High Power Setting, Switch off condition t_3 , t_{off}

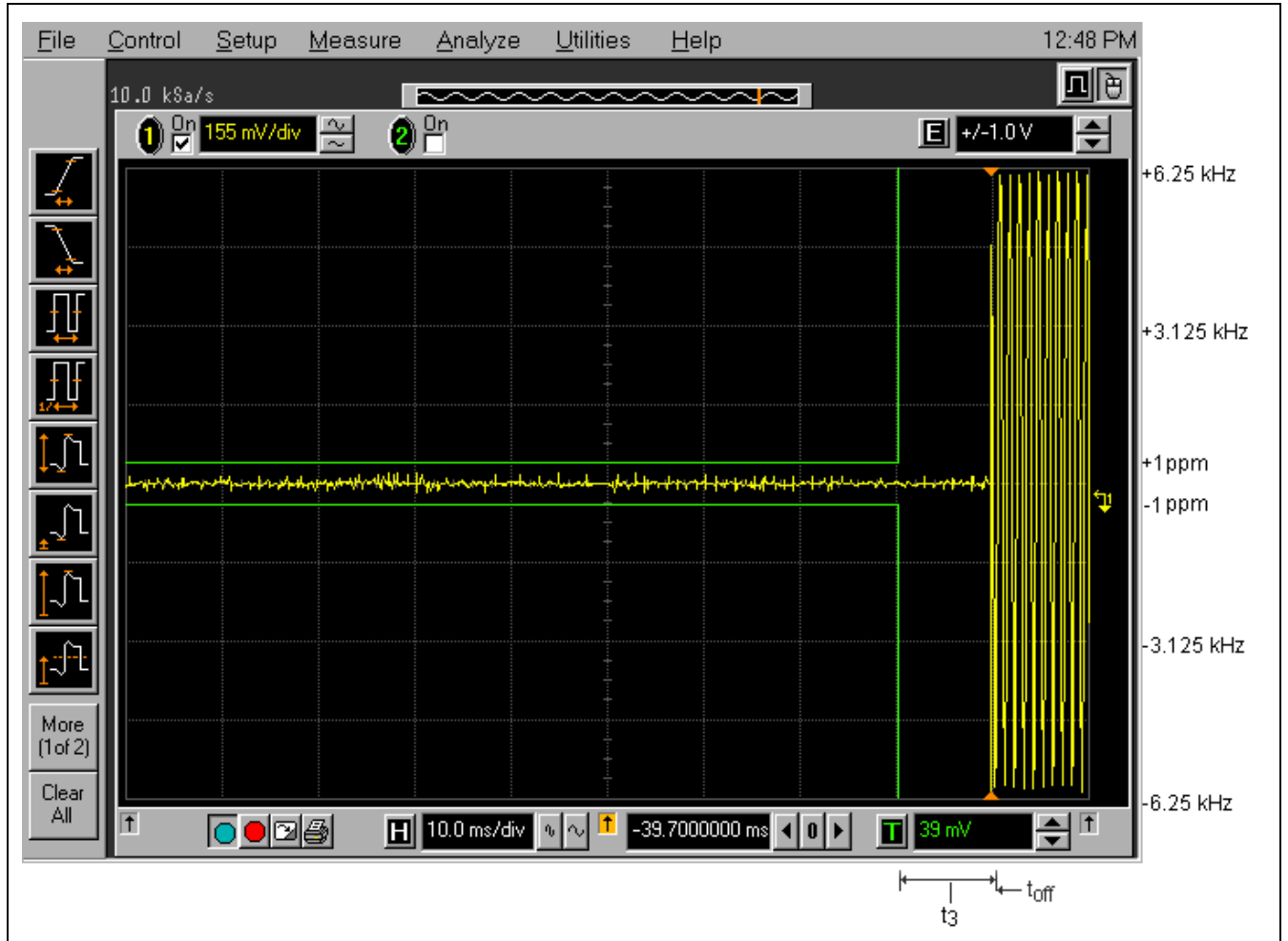

ULTRATECH GROUP OF LABS

3000 Bristol Circle, Oakville, Ontario, Canada L6H 6G4
Tel. #: 905-829-1570, Fax. #: 905-829-8050, Email: vic@ultratech-labs.com, Website: <http://www.ultratech-labs.com>

File #: 15FSG141_FCC90
July 8, 2015

All test results contained in this engineering test report are traceable to National Institute of Standards and Technology (NIST)

5.9. EXPOSURE OF HUMANS TO RF FIELD [[§§ 1.1310 & 2.1091]

§ 1.1310: The criteria listed in the following table shall be used to evaluate the environmental impact of human exposure to radio-frequency (RF) radiation as specified in 1.1307(b).

Limits for Maximum Permissible Exposure (MPE)

Frequency range (MHz)	Electric field strength (V/m)	Magnetic field strength (A/m)	Power density (mW/cm ²)	Averaging time (minutes)
(A) Limits for Occupational/Controlled Exposures				
0.3-3.0	614	1.63	*(100)	6
3.0-30	1842/f	4.89/f	*(900/f ²)	6
30-300	61.4	0.163	1.0	6
300-1500			f/300	6
1500-100,000			5	6
(B) Limits for General Population/Uncontrolled Exposure				
0.3-1.34	614	1.63	*(100)	30
1.34-30	824/f	2.19/f	*(180/f ²)	30
30-300	27.5	0.073	0.2	30
300-1500			f/1500	30
1500-100,000			1.0	30

f = frequency in MHz

* = Plane-wave equivalent power density

Note 1: Occupational/controlled limits apply in situations in which persons are exposed as a consequence of their employment provided those persons are fully aware of the potential for exposure and can exercise control over their exposure. Limits for occupational/controlled exposure also apply in situations when an individual is transient through a location where occupational/controlled limits apply provided he or she is made aware of the potential for exposure.

Note 2: General population/uncontrolled exposures apply in situations in which the general public may be exposed, or in which persons that are exposed as a consequence of their employment may not be fully aware of the potential for exposure or can not exercise control over their exposure.

5.9.1. Method of Measurements

Calculation Method of RF Safety Distance:

$$S = \frac{PG}{4\pi \cdot r^2} = \frac{EIRP}{4\pi \cdot r^2}$$

Where, P: power input to the antenna in mW
 EIRP: Equivalent (effective) isotropic radiated power.
 S: power density mW/cm²
 G: numeric gain of antenna relative to isotropic radiator
 r: distance to centre of radiation in cm

$$r = \sqrt{\frac{PG}{4\pi \cdot S}} = \sqrt{\frac{EIRP}{4\pi \cdot S}}$$

5.9.2. Evaluation of RF Exposure Compliance Requirements

Maximum RF Power conducted, P_{conducted}[dBm]:	34.90
Maximum Antenna Gain, G[dBi]:	2.15
Maximum EIRP, P_{EIRP}[dBm]:	37.05
MPE Limit for Occupational/Controlled Exposure, S_{controlled}[mW/cm²]:	= 380/300 = 1.267
MPE Limit for General Population/Uncontrolled Exposure, S_{uncontrolled}[mW/cm²]	= 380/1500 = 0.253
Calculated RF Safety Distance for Occupational/Controlled Exposure, r_{safety controlled}[cm]:	17.8
Calculated RF Safety Distance for General Population/Uncontrolled Exposure, r_{safety uncontrolled}[cm]	39.9

EXHIBIT 6. TEST EQUIPMENT LIST

Test Instruments	Manufacturer	Model No.	Serial No.	Frequency Range	Cal. Due Date
Average Power Meter	Hewlett Packard	436A	2101A11242	0.0001 - 50 GHz	Mar. 5, 2016
Average Power Sensor	Hewlett Packard	8481A	1550A15143	0.01 - 18 GHz	Sep. 22, 2015
RF communication Test Set	Hewlett Packard	8920B	US39064699	250 kHz – 1 GHz	Jan. 30, 2017
Attenuator	MCE / Weinschel	48-30-34	BM5 354	DC – 18 GHz	Cal on use
DC Block	Hewlett Packard	11742A	12460	0.045 – 26.5 GHz	Cal on use
DC Power Supply	Tenma	72-7295	490300297	1 – 40 Vdc	Cal on use
Modulation Analyzer	Hewlett Packard	8901B	3226A04606	0.15 - 1300 MHz	Jan. 29, 2016
FFT Digital Spectrum Analyzer	Advantest	R9211E	8202336`	10 mHz – 100 kHz	Jan. 27, 2016
Spectrum Analyzer	Rohde & Schwarz	FSEK30	100077	20 Hz - 40 GHz	Nov. 8, 2015
High Pass Filter	Mini-Circuits	SHP-800	10425	Cut off 400 MHz	Cal on use
EMI Receiver	Rohde & Schwarz	ESU40	100037	20 Hz – 40 GHz	May 8, 2017
Pre-Amplifier	Com-Power	PAM-118A	551016	0.5 – 18 GHz	Jan. 16, 2017
Biconi-Log Antenna	ETS Lindgren	3142C	26873	26 – 3000 MHz	Apr. 14, 2016
Horn Antenna	ETS Lindgren	3155	6570	1 – 18 GHz	Sep. 11, 2015
Dipole Antenna	EMCO	3121C	434	30 – 1000 MHz	May 12, 2016
Horn Antenna	EMCO	3155	5061	1 – 18 GHz	Dec. 12, 2015
Signal Generator	Hewlett Packard	8648C	3443U00391	100 kHz – 3.2 GHz	Feb. 2, 2017
Frequency Counter	EIP	545A	2683	10 Hz - 18 GHz	Apr. 24, 2016
Environmental Chamber	Envirotronics	SSH32C	11994847-S-11059	-60 to 177 degree C	Jun. 2, 2016
Attenuator	Macom	3082-6193-10	-	DC - 18 GHz	Cal. on use
Infinium Oscilloscope	Hewlett Packard	54810A	US38380192	500 MHz, 1 GSa/s	Jun. 16, 2015
Power Divider	Mini-Circuits	ZFSC-3-4-S	0105	1-1000 MHz	Cal. on use
RF Detector	Narda	503A-09	0105	0.01-18 GHz	Cal. On use
Bi-Directional Coupler	Narda	3020A	35482	50 – 1000 MHz	Cal. On use

ULTRATECH GROUP OF LABS

3000 Bristol Circle, Oakville, Ontario, Canada L6H 6G4
 Tel. #: 905-829-1570, Fax. #: 905-829-8050, Email: vic@ultratech-labs.com, Website: <http://www.ultratech-labs.com>

File #: 15FSG141_FCC90
 July 8, 2015

All test results contained in this engineering test report are traceable to National Institute of Standards and Technology (NIST)

EXHIBIT 7. MEASUREMENT UNCERTAINTY

The measurement uncertainties stated were calculated in accordance with the requirements of CISPR 16-4-2 @ IEC:2003 and JCGM 100:2008 (GUM 1995) – Guide to the Expression of Uncertainty in Measurement.

7.1. RADIATED EMISSION MEASUREMENT UNCERTAINTY

	Radiated Emission Measurement Uncertainty @ 3m, Horizontal (30-1000 MHz):	Measured (dB)	Limit (dB)
u_c	Combined standard uncertainty: $u_c(y) = \sqrt{\sum_{i=1}^m u_i^2(y)}$	± 2.39	± 2.6
U	Expanded uncertainty U: $U = 2u_c(y)$	± 4.79	± 5.2

	Radiated Emission Measurement Uncertainty @ 3m, Vertical (30-1000 MHz):	Measured (dB)	Limit (dB)
u_c	Combined standard uncertainty: $u_c(y) = \sqrt{\sum_{i=1}^m u_i^2(y)}$	± 2.39	± 2.6
U	Expanded uncertainty U: $U = 2u_c(y)$	± 4.78	± 5.2

	Radiated Emission Measurement Uncertainty @ 3 m, Horizontal & Vertical (1 – 18 GHz):	Measured (dB)	Limit (dB)
u_c	Combined standard uncertainty: $u_c(y) = \sqrt{\sum_{i=1}^m u_i^2(y)}$	± 1.87	Under consideration
U	Expanded uncertainty U: $U = 2u_c(y)$	± 3.75	Under consideration

EXHIBIT 8. MEASUREMENT METHODS

8.1. CONDUCTED POWER MEASUREMENTS

- The following shall be applied to the combination(s) of the radio device and its intended antenna(e).
- If the RF level is user adjustable, all measurements shall be made with the highest power level available to the user for that combination.
- The following method of measurement shall apply to both conducted and radiated measurements.
- The radiated measurements are performed at the Ultratech Calibrated Open Field Test Site.
- The measurement shall be performed using normal operation of the equipment with modulation.

Test procedure shall be as follows:

Step 1: Duty Cycle measurements if the transmitter's transmission is transient

- Using a EMI Receiver with the frequency span set to 0 Hz and the sweep time set at a suitable value to capture the envelope peaks and the duty cycle of the transmitter output signal;
- The duty cycle of the transmitter, $x = \text{Tx on} / (\text{Tx on} + \text{Tx off})$ with $0 < x < 1$, is measure and recorded in the test report. For the purpose of testing, the equipment shall be operated with a duty cycle that is equal or more than 0.1.

Step 2: Calculation of Average EIRP. See Figure 1

- The average output power of the transmitter shall be determined using a wideband, calibrated RF average power meter with the power sensor with an integration period that exceeds the repetition period of the transmitter by a factor 5 or more. The observed value shall be recorded as "A" (in dBm);
- The e.i.r.p. shall be calculated from the above measured power output "A", the observed duty cycle x, and the applicable antenna assembly gain "G" in dBi, according to the formula:

$$\text{EIRP} = \text{A} + \text{G} + 10\log(1/x)$$

{X = 1 for continuous transmission => $10\log(1/x) = 0$ dB}

Figure 1.

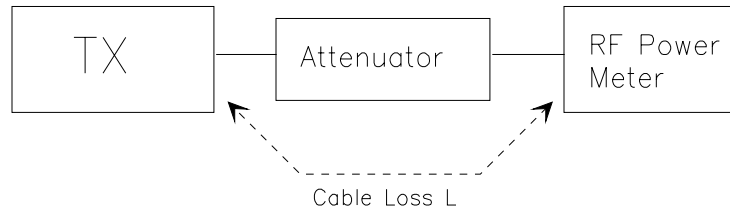

8.2. RADIATED POWER MEASUREMENTS (ERP & EIRP) USING SUBSTITUTION METHOD

8.2.1. MAXIMIZING RF EMISSION LEVEL (E-FIELD)

- (a) The measurements were performed with full rf output power and modulation.
- (b) Test was performed at listed 3m open area test site (listed with FCC, IC, ITI, NVLAP, ACA & VCCI).
- (c) The transmitter under test was placed at the specified height on a non-conducting turntable (80 cm height)
- (d) The BICONILOG antenna (20 MHz to 1 GHz) or HORN antenna (1 GHz to 18 GHz) was used for measuring.
- (e) Load an appropriate correction factors file in EMI Receiver for correcting the field strength reading level

Total Correction Factor recorded in the EMI Receiver = Cable Loss + Antenna Factor
E (dB μ V/m) = Reading (dB μ V) + Total Correction Factor (dB/m)

- (f) Set the EMI Receiver and #2 as follows:

Center Frequency: test frequency
Resolution BW: 100 KHz
Video BW: same
Detector Mode: positive
Average: off
Span: 3 x the signal bandwidth

- (g) The test antenna was lowered or raised from 1 to 4 meters until the maximum signal level was detected.
- (h) The transmitter was rotated through 360° about a vertical axis until a higher maximum signal was received.
- (i) The test antenna was lowered or raised again from 1 to 4 meters until a maximum was obtained. This level was recorded.
- (j) The recorded reading was corrected to the true field strength level by adding the antenna factor, cable loss and subtracting the pre-amplifier gain.
- (k) The above steps were repeated with both transmitters' antenna and test receiving antenna placed in vertical and horizontal polarization. Both readings with the antennas placed in vertical and horizontal polarization shall be recorded.
- (l) Repeat for all different test signal frequencies.

8.2.2. Measuring the EIRP of Spurious/Harmonic Emissions using Substitution Method

(a) Set the EMI Receiver (for measuring E-Field) and Receiver #2 (for measuring EIRP) as follows:

Center Frequency: equal to the signal source
Resolution BW: 100 KHz
Video BW: VBW > RBW
Detector Mode: positive
Average: off
Span: 3 x the signal bandwidth

(b) Load an appropriate correction factors file in EMI Receiver for correcting the field strength reading level

Total Correction Factor recorded in the EMI Receiver = Cable Loss + Antenna Factor
 $E \text{ (dBuV/m)} = \text{Reading (dBuV)} + \text{Total Correction Factor (dB/m)}$

(c) Select the frequency and E-field levels obtained in the Section 8.2.1 for ERP/EIRP measurements.

(d) Substitute the EUT by a signal generator and one of the following transmitting antenna (substitution antenna):

- ◆ DIPOLE antenna for frequency from 30-1000 MHz or
- ◆ HORN antenna for frequency above 1 GHz }.

(e) Mount the transmitting antenna at 1.5 meter high from the ground plane.

(f) Use one of the following antenna as a receiving antenna:

- ◆ DIPOLE antenna for frequency from 30-1000 MHz or
- ◆ HORN antenna for frequency above 1 GHz }.

(g) If the DIPOLE antenna is used, tune it's elements to the frequency as specified in the calibration manual.

(h) Adjust both transmitting and receiving antenna in a VERTICAL polarization.

(i) Tune the EMI Receivers to the test frequency.

(j) Lower or raise the test antenna from 1 to 4 meters until the maximum signal level was detected.

(k) The transmitter was rotated through 360° about a vertical axis until a higher maximum signal was received.

(l) Lower or raise the test antenna from 1 to 4 meters until the maximum signal level was detected.

(m) Adjust input signal to the substitution antenna until an equal or a known related level to that detected from the transmitter was obtained in the test receiver.

(n) Record the power level read from the Average Power Meter and calculate the ERP/EIRP as follows:

$$P = P1 - L1 = (P2 + L2) - L1 = P3 + A + L2 - L1$$

$$\text{EIRP} = P + G1 = P3 + L2 - L1 + A + G1$$

$$\text{ERP} = \text{EIRP} - 2.15 \text{ dB}$$

$$\text{Total Correction factor in EMI Receiver \# 2} = L2 - L1 + G1$$

Where: P: Actual RF Power fed into the substitution antenna port after corrected.
P1: Power output from the signal generator
P2: Power measured at attenuator A input
P3: Power reading on the Average Power Meter
EIRP: EIRP after correction
ERP: ERP after correction

(o) Adjust both transmitting and receiving antenna in a HORIZONTAL polarization, then repeat step (k) to (o)

(p) Repeat step (d) to (o) for different test frequency

(q) Repeat steps (c) to (j) with the substitution antenna oriented in horizontal polarization.

(r) Actual gain of the EUT's antenna is the difference of the measured EIRP and measured RF power at the RF port. Correct the antenna gain if necessary.

Figure 2

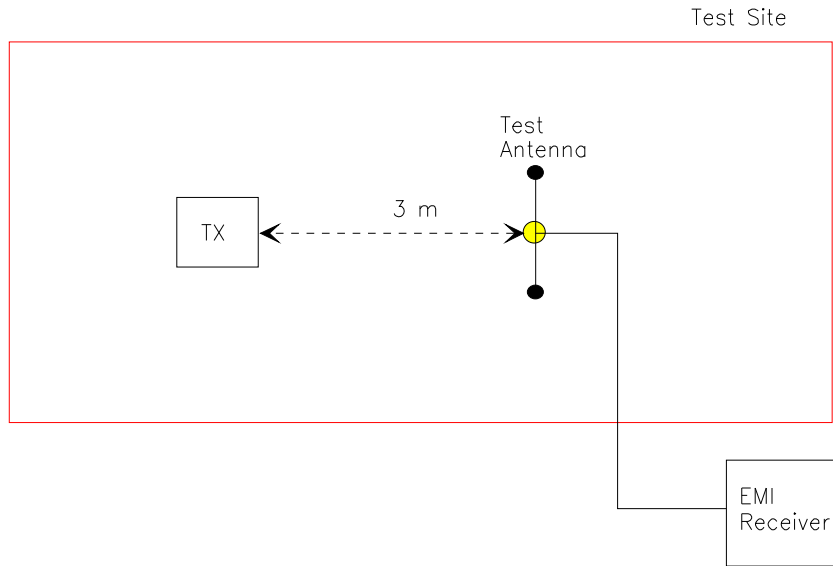
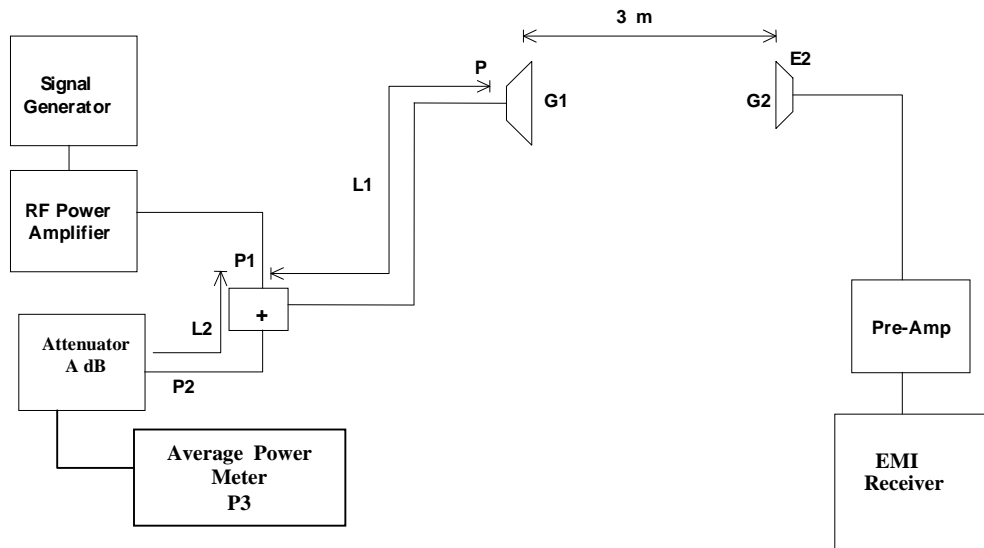

Figure 3



8.3. FREQUENCY STABILITY

Refer to FCC @ 2.1055.

- (a) The frequency stability shall be measured with variation of ambient temperature as follows: From -30 to +50 centigrade except that specified in subparagraph (2) & (3) of this paragraph.
- (b) Frequency measurements shall be made at extremes of the specified temperature range and at intervals of not more than 10 centigrade through the range. A period of time sufficient to stabilize all of the components of the oscillator circuit at each temperature level shall be allowed prior to frequency measurement. The short-term transient effects on the frequency of the transmitter due to keying (except for broadcast transmitters) and any heating element cycling normally occurring at each ambient temperature level also shall be shown. Only the portion or portions of the transmitter containing the frequency determining and stability circuitry need be subjected to the temperature variation test.
- (d) The frequency stability supply shall be measured with variation of primary supply voltage as follows:
 - (1) Vary primary supply voltage from 85 to 115 percent of the nominal value for other than hand carried battery equipment.
 - (2) For hand carried, battery powered equipment, reduce primary supply voltage to the battery operating end point which shall be specified by the manufacturer.
 - (3) The supply voltage shall be measured at the input to the cable normally provide with the equipment, or at the power supply terminals if cables are not normally provided. Effects on frequency of transmitter keying (except for broadcast transmitters) and any heating element cycling at the nominal supply voltage and at each extreme also shall be shown.
- (e) When deemed necessary, the Commission may require tests of frequency stability under conditions in addition to those specifically set out in paragraphs (a), (b), (c) and (d) of this section. (For example, measurements showing the effect of proximity to large metal objects, or of various types of antennas, may be required for portable equipment).

8.4. EMISSION MASK

Voice or Digital Modulation Through a Voice Input Port @ 2.1049(c)(i):- The transmitter was modulated by a 2.5 KHz tone signal at an input level 16 dB greater than that required to produce 50% modulation (e.g.: ± 2.5 KHz peak deviation at 1 KHz modulating frequency). The input level was established at the frequency of maximum response of the audio modulating circuit.

Digital Modulation Through a Data Input Port @ 2.1049(h):- Transmitters employing digital modulation techniques - when modulated by an input signal such that its amplitude and symbol rate represent the maximum rated conditions under which the equipment will be operated. The signal shall be applied through any filter networks, pseudo-random generators or other devices required in normal service. Additionally, the Emission Masks shall be shown for operation with any devices used for modifying the spectrum when such devices are operational at the discretion of the user.

The following EMI Receiver bandwidth shall be used for measurement of Emission Mask/Out-of-Band Emission Measurements:

- (1) For 25 KHz Channel Spacing: RBW = 300 Hz
- (2) For 12.5 KHz or 6.25 KHz Channel Spacings: RBW = 100 Hz

The all cases the Video Bandwidth shall be equal or greater than the measuring bandwidth.

8.5. SPURIOUS EMISSIONS (CONDUCTED)

With transmitter modulation characteristics described in Out-of-Band Emissions measurements @ 2.1049, the transmitter spurious and harmonic emissions were scanned. The spurious and harmonic emissions were measured with the EMI Receiver controls set as RBW = 30 KHz minimum , VBW \geq RBW and SWEEP TIME = AUTO). The transmitter was operated at a full rated power output, and modulated as follows:

FCC 47 CFR 2.1057 - Frequency spectrum to be investigated: The spectrum was investigated from the lowest radio generated in the equipment up to at least the 10th harmonic of the carrier frequency or to the highest frequency practicable in the present state of the art of measuring techniques, whichever is lower. Particular attention should be paid to harmonics and subharmonics of the carrier frequency. Radiation at the frequencies of multiplier stages should be checked. The amplitude of spurious emissions which are attenuated more than 20 dB below the permissible value need not be reported.

FCC 47 CFR 2.1051 - Spurious Emissions at Antenna Terminal: The radio frequency voltage or powers generated within the equipment and appearing on a spurious frequency shall be checked at the equipment output terminals when properly loaded with a suitable artificial antenna. Curves or equivalent data shall show the magnitude of the harmonic and other spurious emission that can be detected when the equipment is operated under the conditions specified in 2.1049 as appropriate. The magnitude of spurious emissions, which are attenuated more than 20 dB below the permissible value, need not be specified.