

ENGINEERING TEST REPORT

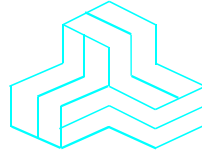

OCR
Model No.: OCR UHF

FCC ID: LO6-OCRUHF

Applicant:

Futurecom Systems Group Inc
3277 Langstaff Road
Concord, Ontario
Canada, L4K 5P8

Tested in Accordance With

Federal Communications Commission (FCC)
47 CFR, Parts 2 and 90

UltraTech's File No.: FSG-053F90

This Test report is Issued under the Authority of
Tri M. Luu, Professional Engineer,
Vice President of Engineering
UltraTech Group of Labs

Date: June 10, 2006



Report Prepared by: Dharmajit Solanki

Tested by: Mr. Hung Trinh, RFI/EMC Technician

Issued Date: June 10, 2006

Test Dates: April 05 – May 11, 2006

- *The results in this Test Report apply only to the sample(s) tested, and the sample tested is randomly selected.*
- *This report must not be used by the client to claim product endorsement by NVLAP or any agency of the US Government.*

UltraTech

3000 Bristol Circle, Oakville, Ontario, Canada, L6H 6G4
Tel.: (905) 829-1570 Fax.: (905) 829-8050

Website: www.ultratech-labs.com, Email: vic@ultratech-labs.com, Email: tri@ultratech-labs.com



0685



31040/SIT



C-1376



46390-2049



200093-0



SL2-IN-E-1119R

TABLE OF CONTENTS

EXHIBIT 1.	INTRODUCTION	2
1.1.	SCOPE.....	2
1.2.	RELATED SUBMITTAL(S)/GRANT(S)	2
1.3.	NORMATIVE REFERENCES	2
EXHIBIT 2.	PERFORMANCE ASSESSMENT	3
2.1.	CLIENT INFORMATION	3
2.2.	EQUIPMENT UNDER TEST (EUT) INFORMATION	3
2.3.	EUT'S TECHNICAL SPECIFICATIONS	4
2.4.	ANCILLARY EQUIPMENT	5
2.5.	TEST ARRANGEMENT	6
EXHIBIT 3.	EUT OPERATING CONDITIONS AND CONFIGURATIONS DURING TESTS	7
3.1.	CLIMATE TEST CONDITIONS	7
3.2.	OPERATIONAL TEST CONDITIONS & ARRANGEMENT FOR TEST SIGNALS.....	7
EXHIBIT 4.	SUMMARY OF TEST RESULTS	8
4.1.	LOCATION OF TESTS.....	8
4.2.	APPLICABILITY & SUMMARY OF EMISSION TEST RESULTS	8
4.3.	MODIFICATIONS INCORPORATED IN THE EUT FOR COMPLIANCE PURPOSES	8
4.4.	DEVIATION OF STANDARD TEST PROCEDURES.....	8
EXHIBIT 5.	MEASUREMENTS, EXAMINATIONS & TEST DATA FOR EMC EMISSIONS	9
5.1.	TEST PROCEDURES.....	9
5.2.	MEASUREMENT UNCERTAINTIES	9
5.3.	MEASUREMENT EQUIPMENT USED	9
5.4.	ESSENTIAL/PRIMARY FUNCTIONS AS DECLARED BY THE MANUFACTURER.....	9
5.5.	RF POWER OUTPUT [§§ 2.1046 & 90.205].....	10
5.6.	FREQUENCY STABILITY [§§ 2.1055 & 90.213].....	13
5.7.	AUDIO FREQUENCY RESPONSE [§ 2.1047(A) & § 90.242(B) (8)].....	15
5.8.	MODULATION LIMITING [§§ 2.1047(B) & 90.210].....	20
5.9.	RF EXPOSURE REQUIREMENT [§§ 1.1310 & 2.1091]	25
5.10.	OCCUPIED BANDWIDTH & EMISSION MASK [§§ 2.1049, 90.209 & 90.210]	28
5.11.	TRANSMITTER ANTENNA POWER SPURIOUS/HARMONIC CONDUCTED EMISSIONS [§§ 2.1051, 90.209 & 90.210]	242
5.12.	TRANSMITTER SPURIOUS/HARMONIC RADIATED EMISSIONS [§90.208 & 90.210].....	291
EXHIBIT 6.	MEASUREMENT UNCERTAINTY	293
6.1.	RADIATED EMISSION MEASUREMENT UNCERTAINTY	293
EXHIBIT 7.	MEASUREMENT METHODS	294
7.1.	CONDUCTED POWER MEASUREMENTS	294
7.2.	RADIATED POWER MEASUREMENTS (ERP & EIRP) USING SUBSTITUTION METHOD.....	295
7.3.	SPURIOUS EMISSIONS (CONDUCTED)	298

EXHIBIT 1. INTRODUCTION

1.1. SCOPE

Reference:	FCC Parts 2 and 90
Title:	Code of Federal Regulations (CFR) Title 47 Telecommunication, Parts 2 & 90
Purpose of Test:	To obtain FCC Equipment Authorization for Radio operating in the frequency bands 380-403 MHz.
Test Procedures:	Both conducted and radiated emissions measurements were conducted in accordance with American National Standards Institute ANSI C63.4 - American National Standard for Methods of Measurement of Radio-Noise Emissions from Low-Voltage Electrical and Electronic Equipment in the Range of 9 kHz to 40 GHz.

1.2. RELATED SUBMITTAL(S)/GRANT(S)

None.

1.3. NORMATIVE REFERENCES

Publication	Year	Title
FCC CFR Parts 0-19, 80-End	2005	Code of Federal Regulations – Telecommunication
ANSI C63.4	2003	American National Standard for Methods of Measurement of Radio-Noise Emissions from Low-Voltage Electrical and Electronic Equipment in the Range of 9 kHz to 40 GHz
TIA/EIA 603, Edition C	2004	Land Mobile FM or PM Communications Equipment Measurement and Performance Standards
CISPR 16-1	2003	Specification for Radio Disturbance and Immunity measuring apparatus and methods

EXHIBIT 2. PERFORMANCE ASSESSMENT

2.1. CLIENT INFORMATION

APPLICANT	
Name:	Futurecom Systems Group Inc.
Address:	3277 Langstaff Road Concord, Ontario Canada L4K 5P8
Contact Person:	Mr. Adam Kolanski Phone #: 905-660-5548 Fax #: 905-660-1380 Email Address: adamk@futurecom.com

MANUFACTURER	
Name:	Futurecom Systems Group Inc.
Address:	3277 Langstaff Road Concord, Ontario Canada, L4K 5P8
Contact Person:	Mr. Adam Kolanski Phone #: 905-660-5548 Fax #: 905-660-1380 Email Address: adamk@futurecom.com

2.2. EQUIPMENT UNDER TEST (EUT) INFORMATION

The following information (with the exception of the Date of Receipt) has been supplied by the applicant.

Brand Name:	Futurecom Systems Group Inc.
Product Name:	OCR
Model Name or Number:	OCR UHF
Serial Number:	06010058 (380-430 MHz) 06010066 (450-470 MHz) 06031208 (470-512 MHz)
Type of Equipment:	Non-broadcast Radio Communication Equipment
Power Supply Requirement:	27.6 V DC
Transmitting/Receiving Antenna Type:	Non-integral
Operational Description:	The OCR receives RF signals from a donor site. It re-transmits amplified RF signals on the same RF frequency.

2.3. EUT'S TECHNICAL SPECIFICATIONS

Transmitter/Repeater	
Equipment Type:	Base Station
Intended Operating Environment:	<input checked="" type="checkbox"/> Commercial <input checked="" type="checkbox"/> Light Industry & Heavy Industry
Power Supply Requirement:	27.6 V DC
RF Output Power Rating:	1 to 30 W (Variable)
Operating Frequency Range:	380-512 MHz
RF Output Impedance:	50 Ohms
Channel Spacing:	12.5 kHz & 25.0 kHz
Type Of Modulation:	Analog Voice and P25 Digital (voice, data)
Occupied Bandwidth (99%):	<ul style="list-style-type: none"> ▪ 9.86 kHz for 12.5 kHz channel spacing ▪ 15.04 kHz for 25 kHz channel spacing ▪ 8.63 kHz for 12.5 kHz channel spacing (digital) ▪ 8.89 kHz for 25 kHz channel spacing (digital)
Emission Designation*:	<ul style="list-style-type: none"> ▪ 11K0F3E for 12.5 kHz channel spacing (Analog Voice) ▪ 16K0F3E for 25 kHz channel spacing (Analog Voice) ▪ 10K8F1E, 10K8F2E, 10K8F1D & 10K8F2D for 12.5kHz & 25kHz Channel spacing (Digital Voice, Data)
Antenna Connector Type:	SMA female

* For an average case of commercial telephony, the Necessary Bandwidth is calculated as follows:

For FM Voice Modulation:

Channel Spacing = 12.5 KHz, D = 2.5 KHz max., K = 1, M = 3 KHz

$$B_n = 2M + 2DK = 2(3) + 2(2.5)(1) = \mathbf{11\ KHz}$$

emission designation: 11K0F3E

Channel Spacing = 25 KHz, D = 5 KHz max., K = 1, M = 3 KHz

$$B_n = 2M + 2DK = 2(3) + 2(5)(1) = \mathbf{16\ KHz}$$

emission designation: 16K0F3E

For P25 Digital Modulation:

Emission Designation: Voice: 10K8F1E, 10K8F2E & Data: 10K8F1D, 10K8F2D

2.3.1. LIST OF EUT'S PORTS

Port Number	EUT's Port Description	Number of Identical Ports	Connector Type	Cable Type (Shielded/Non-shielded)
1	Transmitter	1	SMA	Terminated with 50 Ohm load
2	Receiver	1	SMA	Terminated with 50 Ohm load
3	DC Input/Control	1	96 pin DIN	Non-shielded
4	RS 232	1	8-Pin Mini Din	Shielded

2.4. ANCILLARY EQUIPMENT

The EUT was tested while connected to the following representative configuration of ancillary equipment necessary to exercise the ports during tests:

None

2.5. TEST ARRANGEMENT

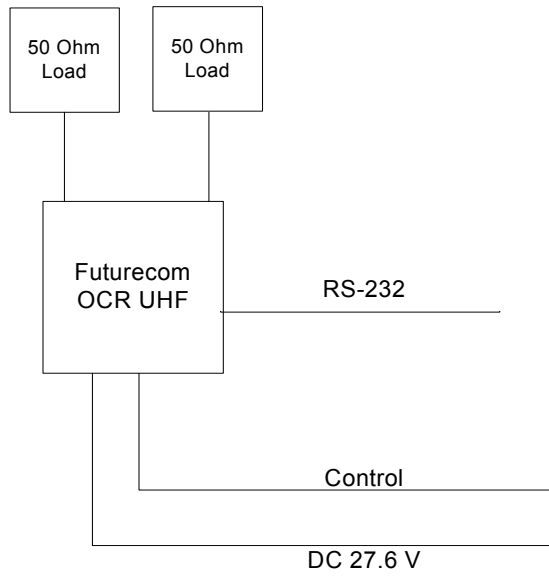

EXHIBIT 3. EUT OPERATING CONDITIONS AND CONFIGURATIONS DURING TESTS

3.1. CLIMATE TEST CONDITIONS

The climate conditions of the test environment are as follows:

Temperature:	22°C
Humidity:	57%
Pressure:	102 kPa
Power input source:	27.6 V DC

3.2. OPERATIONAL TEST CONDITIONS & ARRANGEMENT FOR TEST SIGNALS

Operating Modes:	The transmitter was operated in a continuous transmission mode with the carrier modulated as specified in the Test Data.
Special Test Software:	Operating software provided by Futurecom for selecting operating channel frequency and power
Special Hardware Used:	N/A
Transmitter Test Antenna:	The EUT is tested with the transmitter antenna ports terminated to a 50 Ohms RF Load.

Transmitter Test Signals	
Frequency Band(s):	380 – 512 MHz
Frequencies Tested: (Near lowest, Centre and Highest frequency in each band of operation)	380, 391.5, 403, 406.1, 418.05, 430, 450, 460, 470, 491, 512 MHz
RF Power Output (measured maximum output power):	30 Watts High & 1 Watt Low
Normal Test Modulation:	Unmodulated, FM Voice (analog & digital)
Modulating signal source:	External

EXHIBIT 4. SUMMARY OF TEST RESULTS

4.1. LOCATION OF TESTS

All of the measurements described in this report were performed at Ultratech Group of Labs located in the city of Oakville, Province of Ontario, Canada.

- Radiated Emissions were performed at the Ultratech's 10 TDK Semi-Anechoic Chamber situated in the Town of Oakville, province of Ontario. This test site been calibrated in accordance with ANSI C63.4, and found to be in compliance with the requirements of Sec. 2.948 of the FCC Rules. The descriptions and site measurement data of the Oakville 3-10 TDK Semi-Anechoic Chamber has been filed with FCC office (FCC File No.: 31040/SIT 1300B3) and Industry Canada office (Industry Canada File No.: IC2049-1). Last Date of Site Calibration: June. 20, 2005.

4.2. APPLICABILITY & SUMMARY OF EMISSION TEST RESULTS

FCC Section(s)	Test Requirements	Applicability (Yes/No)
2.1046 & 90.205	RF Power Output	Yes
1.1307, 1.1310, 2.1091 & 2.1093	RF Exposure Limit	Yes
90.213 & 2.1055	Frequency Stability	Yes
2.1047(a)	Audio Frequency Response	Yes
2.1047(b)	Modulation Limiting	Yes
90.209, 90.210 & 2.1049	99% OBW & Emissions Mask	Yes
90.210, 2.1057 & 2.1051	Emission Limits - Spurious Emissions at Antenna Terminal	Yes
90.210, 2.1057 & 2.1051	Emission Limits - Field Strength of Spurious Emissions	Yes
90.214	Transient Frequency Behavior	N/A ¹
OCR, Model No.: OCR UHF, by Futurecom Systems Group Inc. has been tested and found to comply with FCC Part 15, Subpart B - Radio Receivers and Class A Digital Devices. The engineering test report is kept in file and it is available upon request.		

Note 1: Not applicable for Amplifier.

4.3. MODIFICATIONS INCORPORATED IN THE EUT FOR COMPLIANCE PURPOSES

None.

4.4. DEVIATION OF STANDARD TEST PROCEDURES

None.

EXHIBIT 5. MEASUREMENTS, EXAMINATIONS & TEST DATA FOR EMC EMISSIONS

5.1. TEST PROCEDURES

This section contains test results only. Details of test methods and procedures can be found in Exhibit 8 of this report.

5.2. MEASUREMENT UNCERTAINTIES

The measurement uncertainties stated were calculated in accordance with requirements of UKAS Document NIS 81 with a confidence level of 95%. Please refer to Exhibit 7 for Measurement Uncertainties.

5.3. MEASUREMENT EQUIPMENT USED

The measurement equipment used complied with the requirements of the Standards referenced in the Methods & Procedures ANSI C63.4 and CISPR 16-1.

5.4. ESSENTIAL/PRIMARY FUNCTIONS AS DECLARED BY THE MANUFACTURER

The essential function of the EUT is to correctly communicate data/voice to and from radios over RF link.

5.5. RF POWER OUTPUT [§§ 2.1046 & 90.205]

5.5.1. Limits

Please refer to FCC 47 CFR 90.205 for specification details.

5.5.2. Method of Measurements

Refer to Exhibit 7, Sections 7.1 (Conducted) and 7.2 (Radiated) of this report for measurement details

5.5.3. Test Equipment List

Test Instruments	Manufacturer	Model No.	Serial No.	Frequency Range
Attenuator(s)	Weinschel Corp	48-30-34	Bm5354	DC – 8.5 GHz
Power Meter	Hewlett Packard	436A	1725A02249	10 kHz – 50 GHz, sensor dependent
Power Sensor	Hewlett Packard	8481A	2702A68983	10 MHz – 18 GHz

5.5.4. Test Arrangement

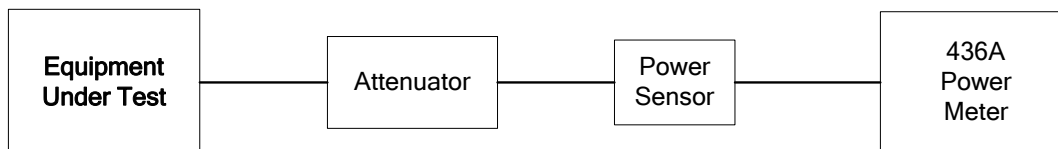

5.5.5. Test Data

Fundamental Frequency (MHz)	Measured Power in (Watts)	Measured Power in (dBm)	Power Rating in (dBm)
Power Setting : High			
380	37.3	45.71	44.77
391.5	32.9	45.17	44.77
403	29.8	44.74	44.77
Power Setting : Low			
380	1.13	30.53	30.0
391.5	1.05	30.21	30.0
403	0.99	29.96	30.0
Power Setting : High			
406.1	32.9	45.17	44.77
418.05	30.5	44.84	44.77
430	29.0	44.62	44.77
Power Setting : Low			
406.1	1.13	30.53	30.0
418.05	1.10	30.41	30.0
430	1.06	30.25	30.0
Power Setting : High			
450	32.2	45.08	44.77
460	30.7	44.87	44.77
470	29.6	44.71	44.77
Power Setting : Low			
450	1.16	30.64	30.0
460	1.11	30.45	30.0
470	1.07	30.29	30.0

Fundamental Frequency (MHz)	Measured Power in (Watts)	Measured Power in (dBm)	Power Rating in (dBm)
Power Setting : High			
470	31.9	45.03	44.77
491	30.2	44.80	44.77
512	30.3	44.81	44.77
Power Setting : Low			
470	1.12	30.49	30.0
491	1.07	30.29	30.0
512	1.05	30.21	30.0

5.6. FREQUENCY STABILITY [§§ 2.1055 & 90.213]

5.6.1. Limits

Refer to FCC 47 CFR 90.213 for specification details.

Frequency Range (MHz)	Channel Bandwidth (kHz)	Frequency Tolerance (ppm)		
		Fixed and Base Stations	Mobile Stations	
			> 2 W	≤ 2 W
421-512 MHz	12.5 25	1.5 2.5	2.5 5.0	2.5 5.0

5.6.2. Method of Measurements

Refer to ULTRATECH Test Procedures, File # ULTR P001-2004 and Exhibit 8 of this report for measurement details.

5.6.3. Test Equipment List

Test Instruments	Manufacturer	Model No.	Serial No.	Frequency Range
Microwave Frequency Counter	EIP Microwave	545A	02683	10 kHz – 18 GHz
Attenuator	Weinschel Corp	23-20-34	BH7876	DC – 18 GHz
Temperature & Humidity Chamber	Tenney	T5	9723B	-40° to +60° C range

5.6.4. Test Arrangement

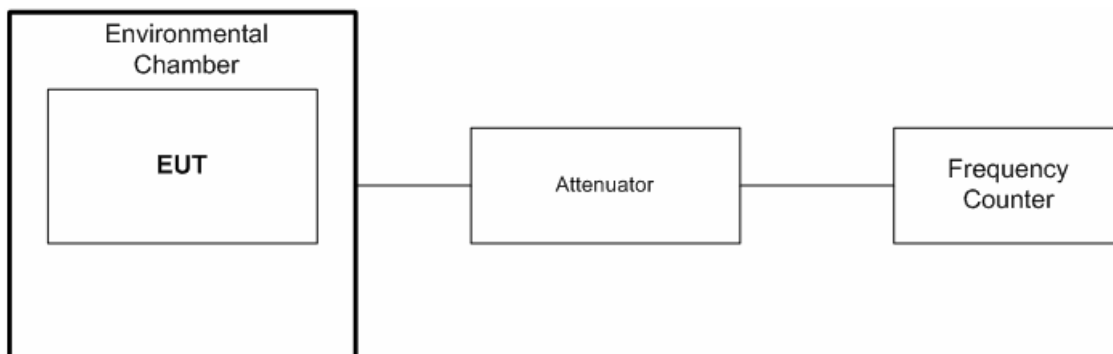

5.6.5. Test Data

Product Name:	OCR
Model No.:	OCR UHF
Center Frequency:	380 MHz
Full Power Level:	44.77 dBm
Frequency Tolerance Limit:	± 1.5 ppm or ± 570 Hz
Max. Frequency Tolerance Measured:	-475 Hz or -1.25 ppm
Input Voltage Rating:	27.6 Vdc

Ambient Temperature (°C)	CENTER FREQUENCY & RF POWER OUTPUT VARIATION		
	Supply Voltage (Nominal) 27.6 Vdc	Supply Voltage (85% of Nominal) 23.46 Vdc	Supply Voltage (115% of Nominal) 31.74 Vdc
	Hz	Hz	Hz
-30	-475	N/A	N/A
-20	-456	N/A	N/A
-10	-371	N/A	N/A
0	-235	N/A	N/A
+10	-95	N/A	N/A
+20	14	9	23
+30	71	N/A	N/A
+40	89	N/A	N/A
+50	39	N/A	N/A
+60	32	N/A	N/A

5.7. AUDIO FREQUENCY RESPONSE [§ 2.1047(a) & § 90.242(b) (8)]

5.7.1. Limits

Recommended audio filter attenuation characteristics are given below:

RF Band	Audio band	Minimum Attenuation Rel. to 1 kHz Attenuation
421-512 MHz	3 –20 kHz 20 – 30 kHz	$60 \log_{10}(f/3)$ dB where f is in kHz 50dB

5.7.2. Method of Measurements

The rated audio input signal was applied to the input of the audio lowpass filter (or of all modulation stages) using an audio oscillator, this input signal level and its corresponding output signal were then measured and recorded using the FFT (Audio) EMI Receiver. Tests were repeated at different audio signal frequencies from 0 to 50 kHz.

5.7.3. Test Equipment List

Test Instruments	Manufacturer	Model No.	Serial No.	Frequency Range
FFT (audio) EMI Receiver	Advantest	R9211E	82020336	10 mHz – 100 kHz, 1 MHz Input Impedance
Radio Communication	Marconi	2955	132037/226	20 Hz – 20 kHz
Synthesized Function Generator	Stanford Research Systems	DS 345	34591	1 μHz – 30.2 MHz

5.7.4. Test Arrangement

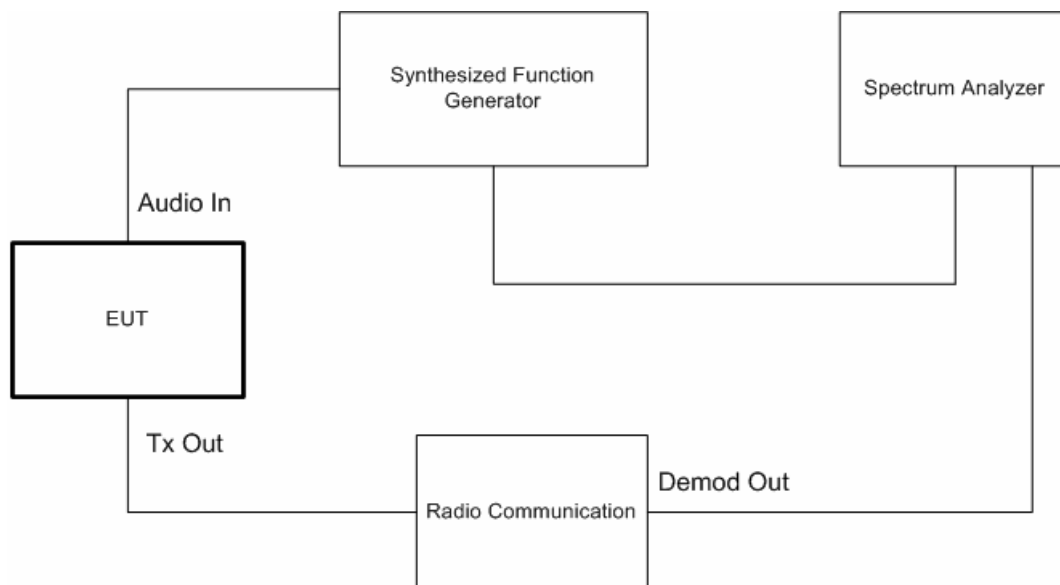

5.7.5. Test Data

5.7.5.1. 12.5 kHz Channel Spacing, Frequency of All Modulation States

FREQUENCY (kHz)	AUDIO IN (dBV)	AUDIO OUT (dBV)	ATTEN. (OUT - IN) (dB)	ATTEN. wrt. 1 kHz (dB)	FCC LIMIT @22.915D (dB)
0.10	11.70	-70.00	-81.7	-69.4	--
0.20	11.70	-57.56	-69.3	-57.0	--
0.40	11.70	-8.31	-20.0	-7.8	--
0.60	11.70	-4.97	-16.7	-4.4	--
0.80	11.70	-2.36	-14.1	-1.8	--
1.00	11.70	-0.56	-12.3	0.0	--
1.50	11.70	2.43	-9.3	3.0	--
2.00	11.70	2.73	-9.0	3.3	--
2.50	11.70	2.82	-8.9	3.4	--
3.00	11.70	1.71	-10.0	2.3	0
3.50	11.70	0.71	-11.0	1.3	-4
4.00	11.70	-8.66	-20.4	-8.1	-7
4.50	11.70	-62.17	-73.9	-61.6	-11
5.00	11.70	-70.00	-81.7	-69.4	-13
6.00	11.70	-80.00	-91.7	-79.4	-18
7.00	11.70	<-80.00	<-91.7	<-79.4	-22
8.00	11.70	<-80.00	<-91.7	<-79.4	-26
9.00	11.70	<-80.00	<-91.7	<-79.4	-29
10.00	11.70	<-80.00	<-91.7	<-79.4	-31
12.00	11.70	<-80.00	<-91.7	<-79.4	-36
14.00	11.70	<-80.00	<-91.7	<-79.4	-40
16.00	11.70	<-80.00	<-91.7	<-79.4	-44
18.00	11.70	<-80.00	<-91.7	<-79.4	-47
20.00	11.70	<-80.00	<-91.7	<-79.4	-49
22.00	11.70	<-80.00	<-91.7	<-79.4	-50
25.00	11.70	<-80.00	<-91.7	<-79.4	-50
30.00	11.70	<-80.00	<-91.7	<-79.4	-50
35.00	11.70	<-80.00	<-91.7	<-79.4	-50
40.00	11.70	<-80.00	<-91.7	<-79.4	-50
45.00	11.70	<-80.00	<-91.7	<-79.4	-50
50.00	11.70	<-80.00	<-91.7	<-79.4	-50

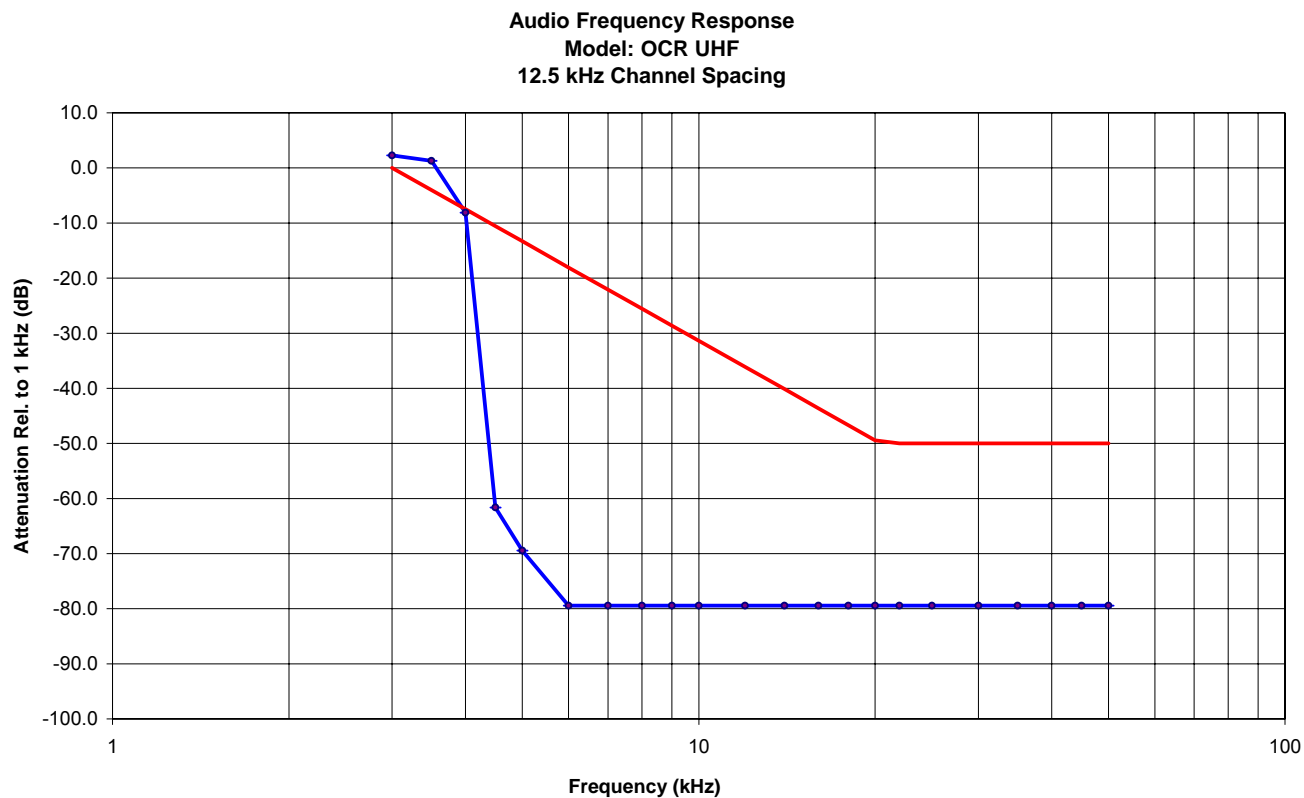

5.7.5.2. 25 kHz Channel Spacing, Frequency of All Modulation States

FREQUENCY (kHz)	AUDIO IN (dBV)	AUDIO OUT (dBV)	ATTEN. (OUT - IN) (dB)	ATTEN. wrt. 1 kHz (dB)	FCC LIMIT @22.915D (dB)
0.10	-11.50	-70.00	-58.5	-75.3	--
0.20	-11.50	-51.45	-40.0	-56.8	--
0.40	-11.50	-2.44	9.1	-7.7	--
0.60	-11.50	0.76	12.3	-4.5	--
0.80	-11.50	3.34	14.8	-2.0	--
1.00	-11.50	5.30	16.8	0.0	--
1.50	-11.50	8.29	19.8	3.0	--
2.00	-11.50	8.56	20.1	3.3	--
2.50	-11.50	8.47	20.0	3.2	--
3.00	-11.50	7.78	19.3	2.5	0
3.50	-11.50	7.02	18.5	1.7	-4
4.00	-11.50	-2.23	9.3	-7.5	-7
4.50	-11.50	-56.80	-45.3	-62.1	-11
5.00	-11.50	-70.00	-58.5	-75.3	-13
6.00	-11.50	-80.00	-68.5	-85.3	-18
7.00	-11.50	<-80.00	<-68.5	<-85.3	-22
8.00	-11.50	<-80.00	<-68.5	<-85.3	-26
9.00	-11.50	<-80.00	<-68.5	<-85.3	-29
10.00	-11.50	<-80.00	<-68.5	<-85.3	-31
12.00	-11.50	<-80.00	<-68.5	<-85.3	-36
14.00	-11.50	<-80.00	<-68.5	<-85.3	-40
16.00	-11.50	<-80.00	<-68.5	<-85.3	-44
18.00	-11.50	<-80.00	<-68.5	<-85.3	-47
20.00	-11.50	<-80.00	<-68.5	<-85.3	-49
22.00	-11.50	<-80.00	<-68.5	<-85.3	-50
25.00	-11.50	<-80.00	<-68.5	<-85.3	-50
30.00	-11.50	<-80.00	<-68.5	<-85.3	-50
35.00	-11.50	<-80.00	<-68.5	<-85.3	-50
40.00	-11.50	<-80.00	<-68.5	<-85.3	-50
45.00	-11.50	<-80.00	<-68.5	<-85.3	-50
50.00	-11.50	<-80.00	<-68.5	<-85.3	-50

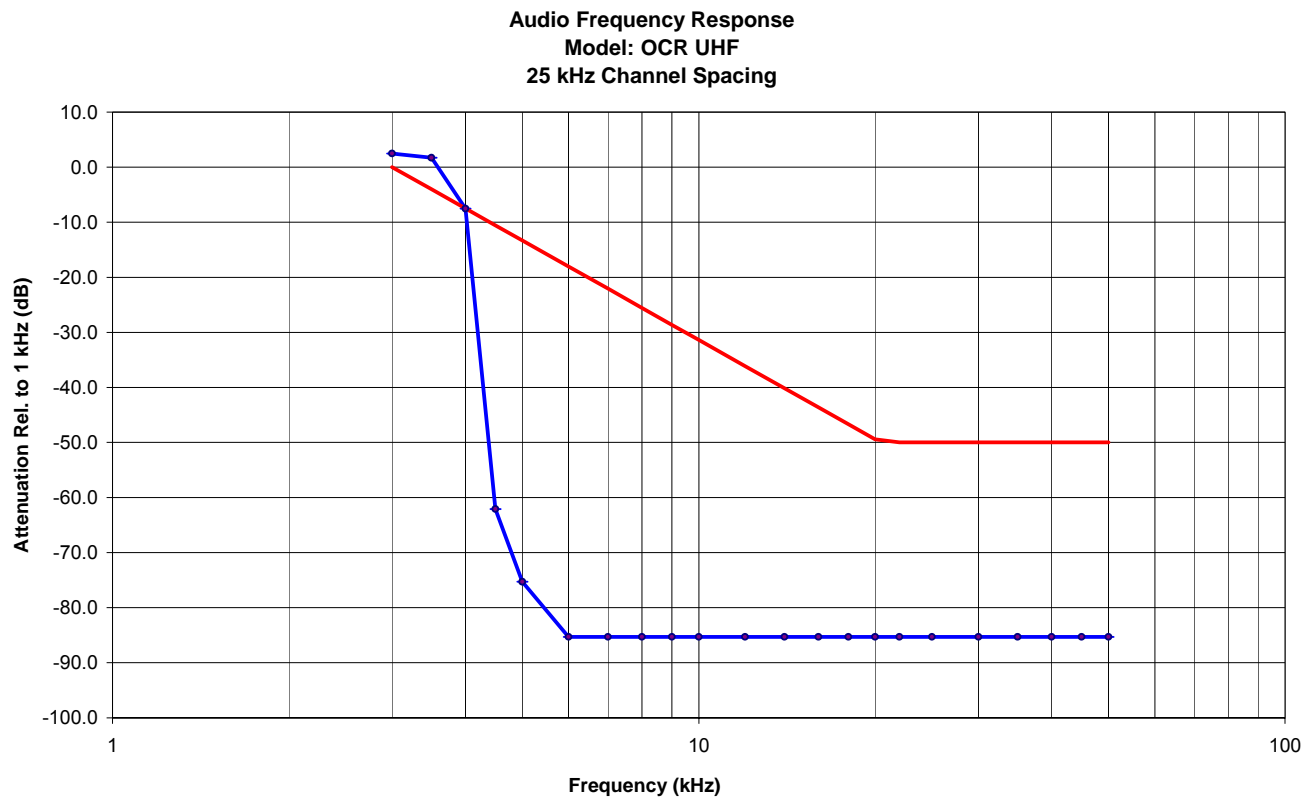

5.8. MODULATION LIMITING [§§ 2.1047(b) & 90.210]

5.8.1. Limits

Recommended frequency deviation characteristics are given below:

- 2.5 kHz for 12.5 kHz Channel Spacing
- 5 kHz for 25 kHz Channel Spacing System

5.8.2. Method of Measurements

Refer to ULTRATECH Test Procedures, File # ULTR P001-2004.

5.8.3. Test Equipment List

Test Instruments	Manufacturer	Model No.	Serial No.	Frequency Range
Synthesized Function Generator	Stanford Research Systems	DS 345	34591	1 μ Hz – 30.2 MHz
Modulation Analyzer	HP	8910B	3226A04606	150 kHz – 1300 MHz

5.8.4. Test Arrangement

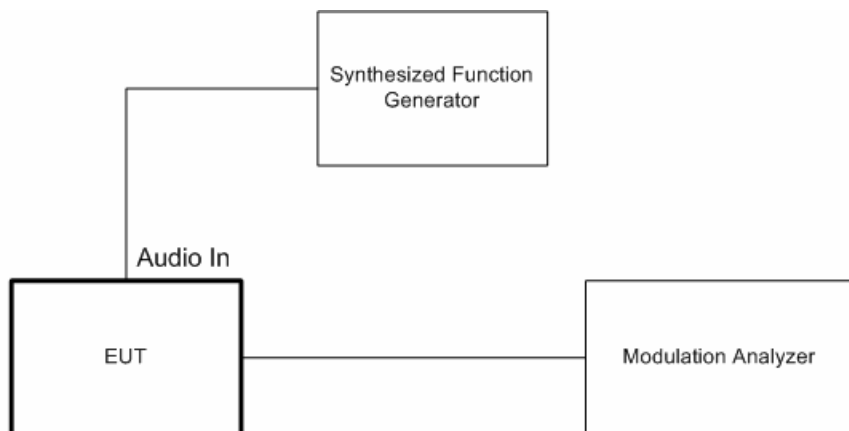

5.8.5. Test Data

5.8.5.1. Voice Modulation Limiting for 12.5 kHz Channel Spacing Operation with High Power setting @ 470 MHz

MODULATING SIGNAL LEVEL (mVrms)	PEAK FREQUENCY DEVIATION (kHz) at the following modulating frequency:					MAXIMUM LIMIT (kHz)
	0.1 kHz	0.5 kHz	1.0 kHz	3.0 kHz	5.0 kHz	
10	0.06	0.07	0.10	0.20	0.06	2.5
50	0.06	0.18	0.32	0.81	0.06	2.5
100	0.06	0.31	0.58	1.56	0.06	2.5
150	0.06	0.45	0.87	2.10	0.06	2.5
200	0.06	0.59	1.16	2.11	0.06	2.5
250	0.06	0.73	1.44	2.12	0.06	2.5
300	0.06	0.87	1.72	2.13	0.06	2.5
350	0.06	1.00	1.99	2.15	0.07	2.5
400	0.06	1.14	2.06	2.15	0.07	2.5
450	0.06	1.27	2.08	2.25	0.08	2.5
500	0.06	1.41	2.08	2.32	0.08	2.5
600	0.06	1.70	2.09	2.32	0.08	2.5
700	0.06	1.96	2.12	2.32	0.09	2.5
800	0.06	2.03	2.12	2.32	0.09	2.5
900	0.06	2.03	2.12	2.32	0.10	2.5
1000	0.06	2.03	2.12	2.32	0.11	2.5
1500	0.35	2.03	2.12	2.32	0.12	2.5

Voice Signal Input Level = STD MOD Level + 16 dB
= 260 mVrms + 16 dB
= 48.30 dBmV + 16 dB
= 64.30 dBmV
= 1640.5 Vrms

MODULATING FREQUENCY (KHz)	PEAK FREQUENCY DEVIATION (KHz)	MAXIMUM LIMIT (KHz)
0.1	0.45	2.5
0.2	1.02	2.5
0.4	2.07	2.5
0.6	2.08	2.5
0.8	2.08	2.5
1.0	2.12	2.5
1.2	2.16	2.5
1.4	2.12	2.5
1.6	2.13	2.5
1.8	2.13	2.5
2.0	2.15	2.5
2.5	2.17	2.5
3.0	2.35	2.5
3.5	2.06	2.5
4.0	1.60	2.5
4.5	0.25	2.5
5.0	0.14	2.5
6.0	0.25	2.5
7.0	0.77	2.5
8.0	1.11	2.5
9.0	1.24	2.5
10.0	0.12	2.5

5.8.5.2. Voice Modulation Limiting for 25 kHz Channel Spacing Operation with High Power setting @ 470 MHz

MODULATING SIGNAL LEVEL (mVrms)	PEAK FREQUENCY DEVIATION (kHz) at the following modulating frequency:					MAXIMUM LIMIT (kHz)
	0.1 kHz	0.5 kHz	1.0 kHz	3.0 kHz	5.0 kHz	
10	0.06	0.10	0.16	0.36	0.06	5
50	0.06	0.32	0.60	1.65	0.06	5
100	0.06	0.59	1.16	3.24	0.06	5
150	0.06	0.86	1.70	4.10	0.07	5
200	0.06	1.16	2.28	4.11	0.07	5
250	0.06	1.43	2.85	4.11	0.07	5
300	0.06	1.70	3.39	4.11	0.08	5
350	0.06	1.97	3.94	4.22	0.09	5
400	0.06	2.24	4.09	4.22	0.10	5
450	0.06	2.52	4.11	4.22	0.11	5
500	0.06	2.79	4.15	4.22	0.11	5
600	0.06	3.35	4.14	4.36	0.12	5
700	0.06	3.90	4.16	4.50	0.14	5
800	0.06	4.01	4.16	4.53	0.16	5
900	0.06	4.01	4.16	4.53	0.16	5
1000	0.06	4.01	4.16	4.53	0.18	5
1500	0.66	4.01	4.16	4.53	0.25	5

Voice Signal Input Level = STD MOD Level + 16 dB
= 265 mVrms + 16 dB
= 48.46 dBmV + 16 dB
= 64.46 dBmV
= 1672.04 Vrms

MODULATING FREQUENCY (KHz)	PEAK FREQUENCY DEVIATION (KHz)	MAXIMUM LIMIT (KHz)
0.1	0.93	5.0
0.2	2.13	5.0
0.4	4.07	5.0
0.6	4.10	5.0
0.8	4.10	5.0
1.0	4.16	5.0
1.2	4.28	5.0
1.4	4.16	5.0
1.6	4.18	5.0
1.8	4.19	5.0
2.0	4.25	5.0
2.5	4.13	5.0
3.0	4.54	5.0
3.5	4.04	5.0
4.0	3.15	5.0
4.5	0.66	5.0
5.0	0.25	5.0
6.0	0.53	5.0
7.0	1.79	5.0
8.0	2.24	5.0
9.0	2.71	5.0
10.0	0.22	5.0

5.9. RF EXPOSURE REQUIREMENT [§§ 1.1310 & 2.1091]

The criteria listed in table 1 shall be used to evaluate the environmental impact of human exposure to radiofrequency (RF) radiation as specified in RSS-102

FCC 47 CFR 1.1310:

TABLE 1—LIMITS FOR MAXIMUM PERMISSIBLE EXPOSURE (MPE)				
Frequency range (MHz)	Electric field strength (V/m)	Magnetic field strength (A/m)	Power density (mW/cm ²)	Averaging time (minutes)
(A) Limits for Occupational/Controlled Exposures				
0.3–3.0	614	1.63	*(100)	6
3.0–30	1842/f	4.89/f	*(900/f ²)	6
30–300	61.4	0.163	1.0	6
300–1500	f/300	6
1500–100,000	5	6
(B) Limits for General Population/Uncontrolled Exposure				
0.3–1.34	614	1.63	*(100)	30
1.34–30	824/f	2.19/f	*(180/f ²)	30
30–300	27.5	0.073	0.2	30
300–1500	f/1500	30
1500–100,000	1.0	30
f = frequency in MHz				
* = Plane-wave equivalent power density				
NOTE 1 TO TABLE 1: Occupational/controlled limits apply in situations in which persons are exposed as a consequence of their employment provided those persons are fully aware of the potential for exposure and can exercise control over their exposure. Limits for occupational/controlled exposure also apply in situations when an individual is transient through a location where occupational/controlled limits apply provided he or she is made aware of the potential for exposure.				
NOTE 2 TO TABLE 1: General population/uncontrolled exposures apply in situations in which the general public may be exposed, or in which persons that are exposed as a consequence of their employment may not be fully aware of the potential for exposure or can not exercise control over their exposure.				

5.9.1. Method of Measurements

Refer to FCC @ 1.1310 and 2.1091

- In order to demonstrate compliance with MPE requirements (see Section 2.1091), the following information is typically needed:
 - (1) Calculation that estimates the minimum separation distance (20 cm or more) between an antenna and persons required to satisfy power density limits defined for free space.
 - (2) Antenna installation and device operating instructions for installers (professional/unskilled users), and the parties responsible for ensuring compliance with the RF exposure requirement.
 - (3) Any caution statements and/or warning labels that are necessary in order to comply with the exposure limits.
 - (4) Any other RF exposure related issues that may affect MPE compliance.

Calculation Method of RF Safety Distance:

$$S = PG/4\pi r^2 = EIRP/4\pi r^2$$

Where: P: power input to the antenna in mW
EIRP: Equivalent (effective) isotropic radiated power.
S: power density mW/cm²
G: numeric gain of antenna relative to isotropic radiator
r: distance to centre of radiation in cm

$$r = \sqrt{PG/4\pi S}$$

- For portable transmitters (see Section 2.1093), or devices designed to operate next to a person's body, compliance is determined with respect to the SAR limit (define in the body tissues) for near-field exposure conditions. If the maximum average output power, operating condition configurations and exposure conditions are comparable to those of existing cellular and PCS phones, SAR evaluation may be required in order to determine if such a device complies with SAR limit. When SAR evaluation data is not available, and the additional supporting information cannot assure compliance, the Commission may request that an SAR evaluation be performed, as provided for in Section 1.1307(d).

5.9.2. Test Data

Antenna Gain Limit specified by Manufacturer: No Specific Gain Specified

As an **Example** to show how to calculate MPE safe distance, antenna with a gain of 2.15 dBi is considered and calculations are as per below.

(1) Lowest Frequency (MHz)	Measured Peak RF Conducted Power (dBm)	Calculated EIRP (dBm)	Exposure Condition	Calculated Minimum RF Safety Distance r (cm)*
380	45.72	47.87	Occupational	62.0
380	45.72	47.87	Bystanders	138.7

* The minimum separation distance between the antenna and bodies of users are calculated using the following formula:

RF EXPOSURE DISTANCE LIMITS: $r = (PG/4\pi S)^{1/2} = (EIRP/4\pi S)^{1/2}$

Occupational/ Control Exposures: $S = f/300 = 380/300 \text{ mW/cm}^2$

For bystanders/ Uncontrolled Exposure: $S = f/1500 = 380/1500 \text{ mW/cm}^2$

Occupational: $r = (EIRP/4\pi S)^{1/2} = (61,235/(4\pi(380/300)))^{1/2} = 62.0 \text{ cm}$

For bystanders: $r = (EIRP/4\pi S)^{1/2} = (61,235/(4\pi(380/1500)))^{1/2} = 138.7 \text{ cm}$

Evaluation of RF Exposure Compliance Requirements	
RF Exposure Requirements	Compliance with FCC Rules
Minimum calculated separation distance between antenna and persons required:	Manufacturer' instruction for separation distance between antenna and persons required: Will be determined by the User at time of antenna installation using the table 1 given in User Manual.
Antenna installation and device operating instructions for installers (professional/unskilled users), and the parties responsible for ensuring compliance with the RF exposure requirement	Please refer to User's Manual for details.
Caution statements and/or warning labels that are necessary in order to comply with the exposure limits	Please refer to User's Manual for RF Exposure Information.
Any other RF exposure related issues that may affect MPE compliance	None.

5.10. OCCUPIED BANDWIDTH & EMISSION MASK [§§ 2.1049, 90.209 & 90.210]

5.10.1. Limits

Emissions shall be attenuated below the mean output power of the transmitter as follows:

Frequency Band (MHz)	Maximum Authorized BW (kHz)	Channel Spacing (kHz)	FCC Applicable Mask @ FCC 90.210
403-512	11.25	12.5	MASK D
403-512	20	25	MASK B

5.10.2. Test Equipment List

Test Instruments	Manufacturer	Model No.	Serial No.	Frequency Range
Spectrum Analyzer	HP	8953EM	3710A00237	9 kHz – 22 GHz
Attenuator(s)	Weinschel Corp	23-20-34	BH7876	DC – 18 GHz
Radio Communication Test Set	Marconi	2955	132037/226	20Hz – 20kHz
Digital Multimeter	Rohde & Schwarz	UDS-5	8729841067	DC-100 kHz

5.10.3. Test Arrangement

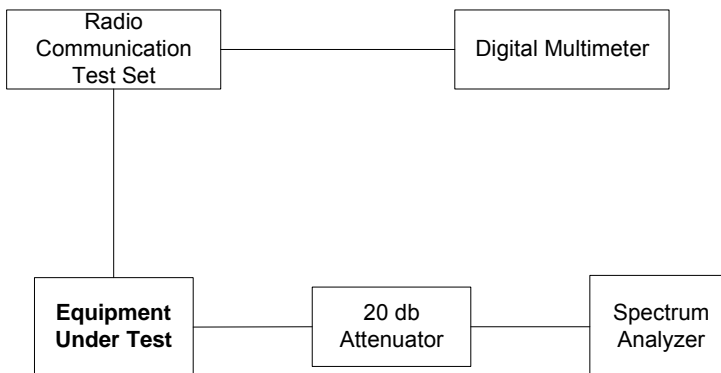

5.10.4. Test Data

5.10.4.1. 99% Occupied Bandwidth Measurements

Frequency (MHz)	Channel Spacing (kHz)	Modulation	*Measured 99% OBW at Maximum Freq. Deviation (kHz)	Maximum Authorized Bandwidth (kHz)
391.5	12.5	FM with 2.5 kHz sine wave signal	9.80	11.25
391.5	25.0	FM with 2.5 kHz sine wave signal	15.04	20.0
391.5	12.5	C4FM Digital Modulation	8.51	11.25
391.5	25.0	C4FM Digital Modulation	8.89	20.0
418.05	12.5	FM with 2.5 kHz sine wave signal	9.86	11.25
418.05	25.0	FM with 2.5 kHz sine wave signal	15.04	20.0
418.05	12.5	C4FM Digital Modulation	8.51	11.25
418.05	25.0	C4FM Digital Modulation	8.66	20.0
460.0	12.5	FM with 2.5 kHz sine wave signal	9.77	11.25
460.0	25.0	FM with 2.5 kHz sine wave signal	15.00	20.0
460.0	12.5	C4FM Digital Modulation	8.57	11.25
460.0	25.0	C4FM Digital Modulation	8.74	20.0
491.0	12.5	FM with 2.5 kHz sine wave signal	9.86	11.25
491.0	25.0	FM with 2.5 kHz sine wave signal	14.83	20.0
491.0	12.5	C4FM Digital Modulation	8.63	11.25
491.0	25.0	C4FM Digital Modulation	8.66	20.0

*Refer to the following test data plots (1 through 16) for details.

PLOT # 1 **99% Occupied Bandwidth**
Frequency: 391.5 MHz, 12.5 kHz Channel Spacing
Modulation: FM modulation with 2.5 kHz sine wave signal

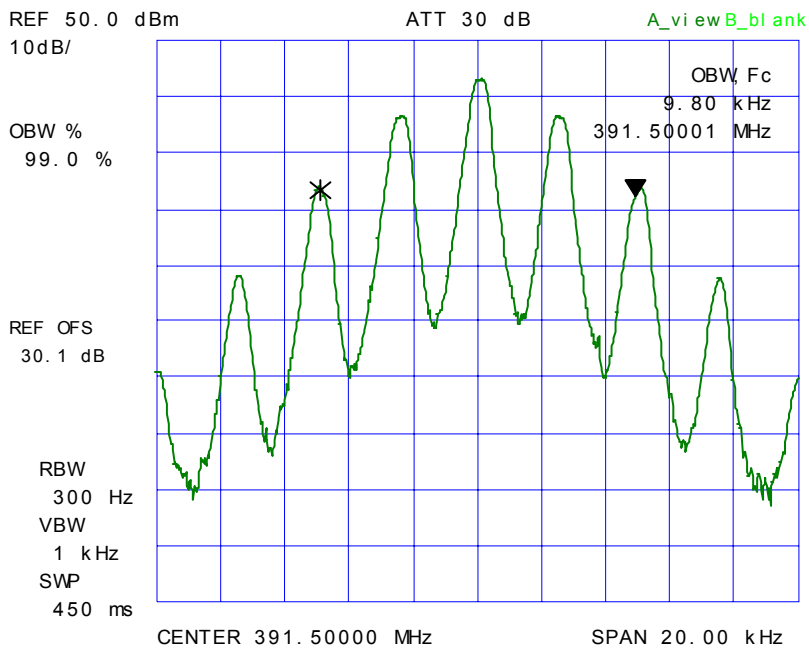

PLOT # 2 **99% Occupied Bandwidth**
Frequency: 391.5 MHz, 25 kHz Channel Spacing
Modulation: FM modulation with 2.5 kHz sine wave signal

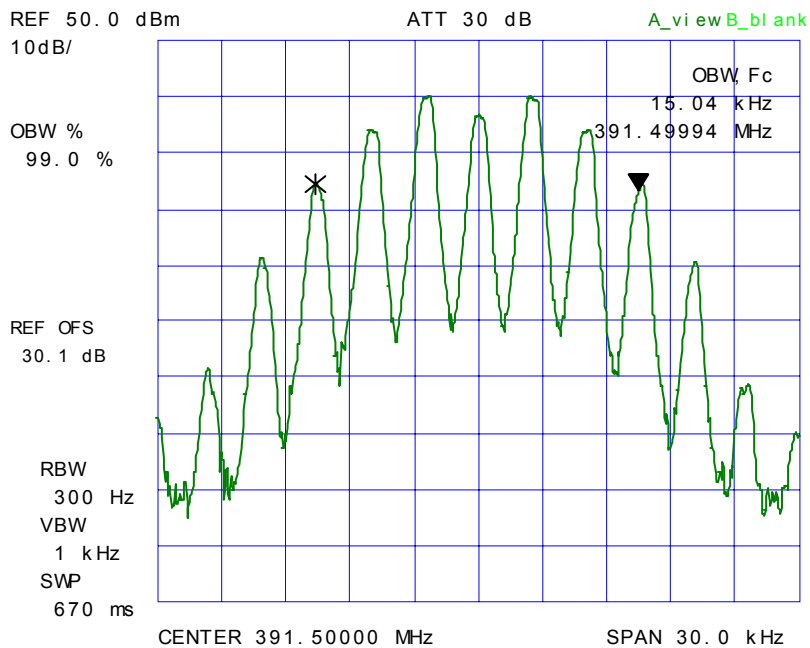

PLOT # 3 **99% Occupied Bandwidth**
Frequency: 391.5 MHz, 12.5 kHz Channel Spacing
Modulation: C4FM digital modulation

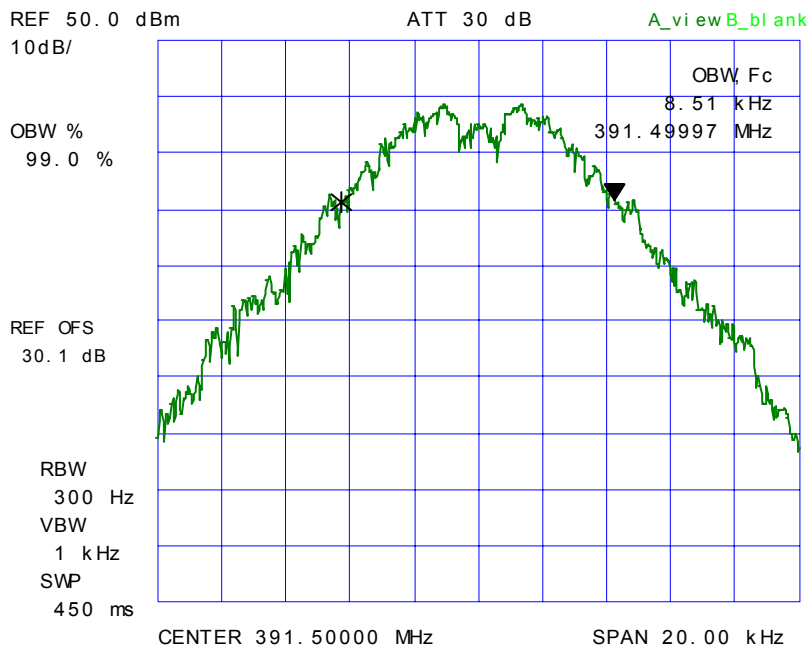

PLOT # 4 **99% Occupied Bandwidth**
Frequency: 391.5 MHz, 25 kHz Channel Spacing
Modulation: C4FM digital modulation

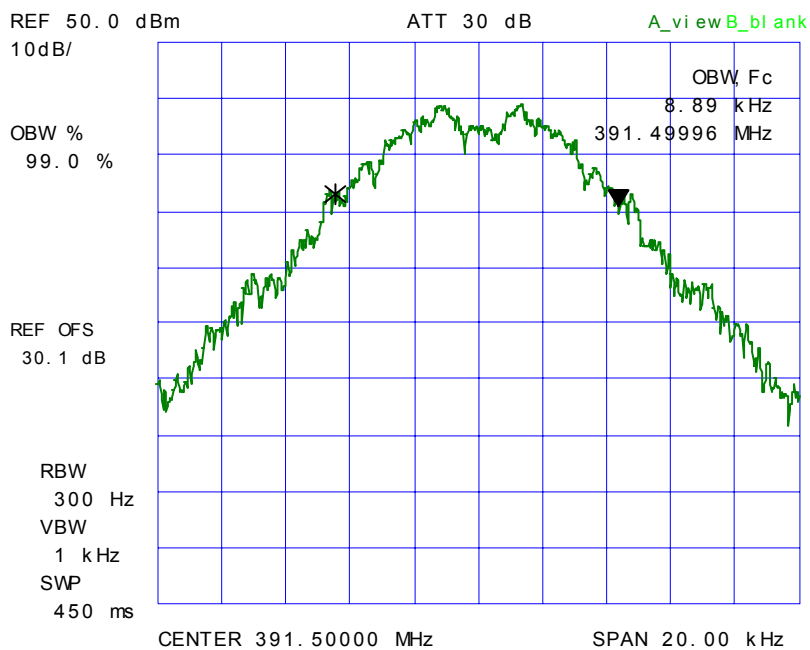

PLOT # 5 **99% Occupied Bandwidth**
Frequency: 418.05 MHz, 12.5 kHz Channel Spacing
Modulation: FM modulation with 2.5 kHz sine wave signal

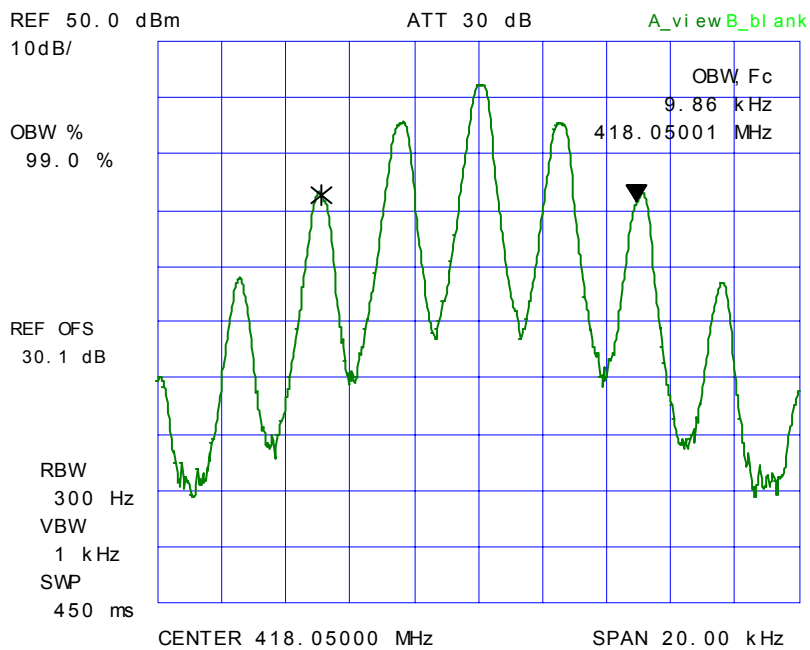

PLOT # 6 **99% Occupied Bandwidth**
Frequency: 418.05 MHz, 25 kHz Channel Spacing
Modulation: FM modulation with 2.5 kHz sine wave signal

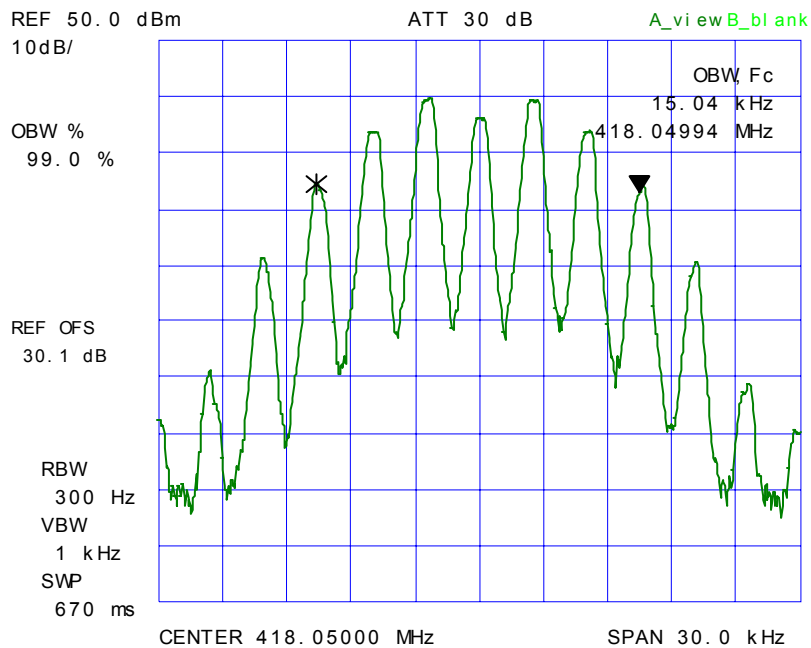

PLOT # 7 **99% Occupied Bandwidth**
Frequency: 418.05 MHz, 12.5 kHz Channel Spacing
Modulation: C4FM digital modulation

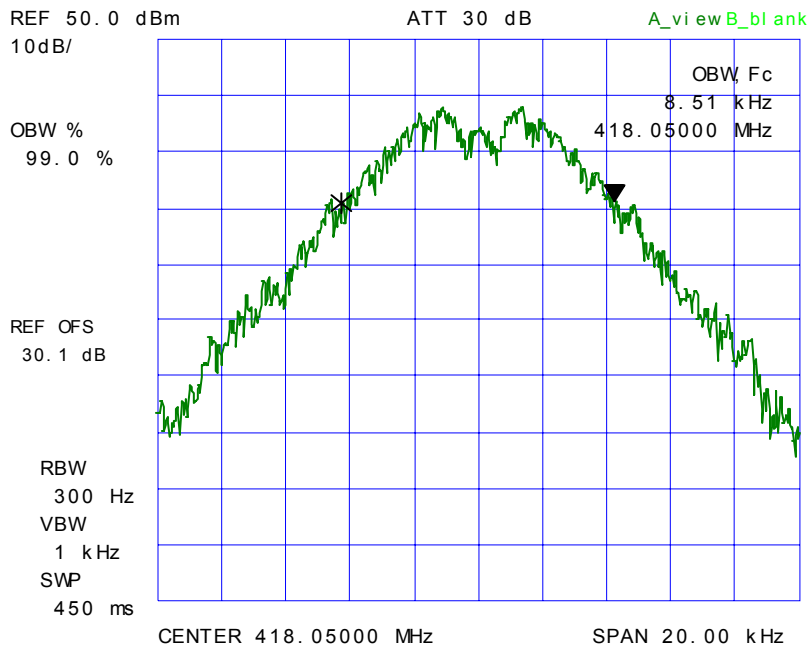

PLOT # 8 **99% Occupied Bandwidth**
Frequency: 418.05 MHz, 25 kHz Channel Spacing
Modulation: C4FM digital modulation

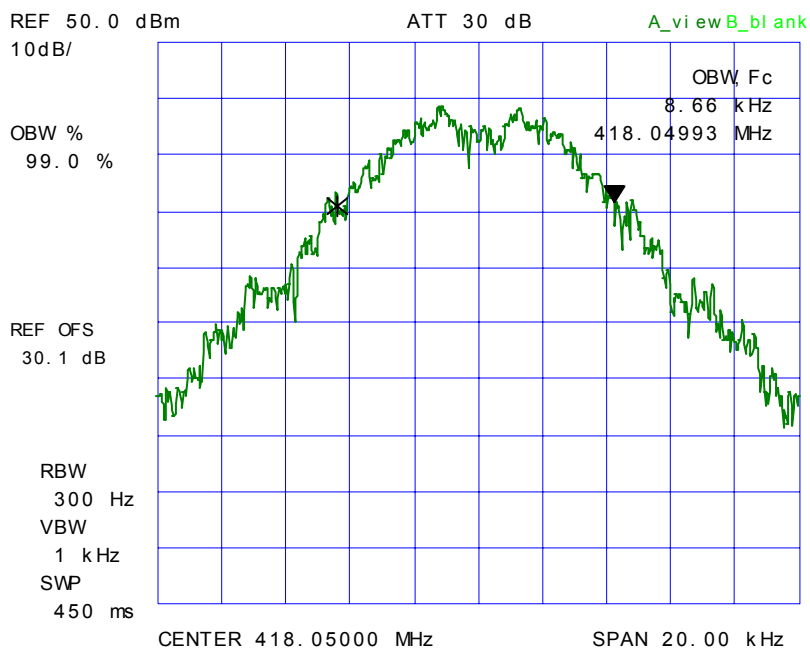

PLOT # 9 **99% Occupied Bandwidth**
Frequency: 460 MHz, 12.5 kHz Channel Spacing
Modulation: FM modulation with 2.5 kHz sine wave signal

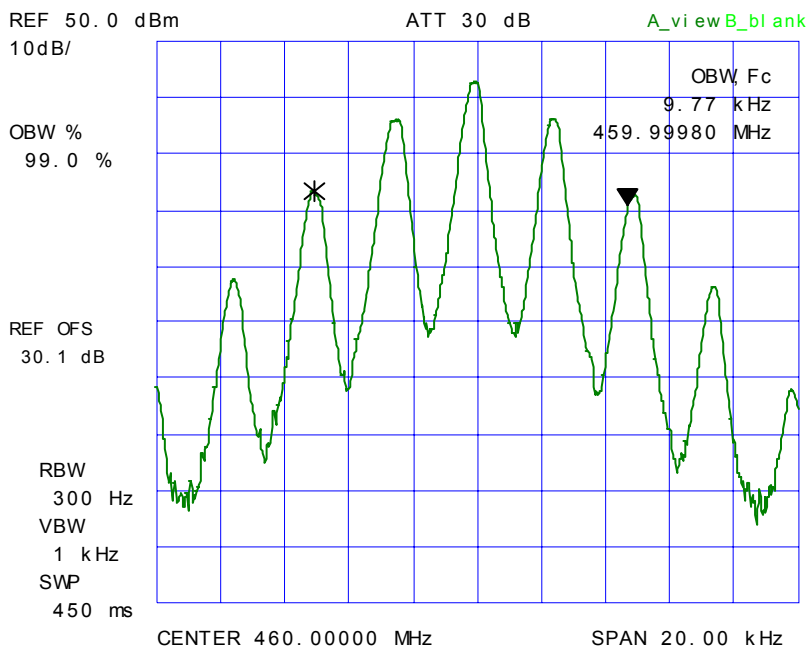

PLOT # 10 **99% Occupied Bandwidth**
Frequency: 460 MHz, 25 kHz Channel Spacing
Modulation: FM modulation with 2.5 kHz sine wave signal

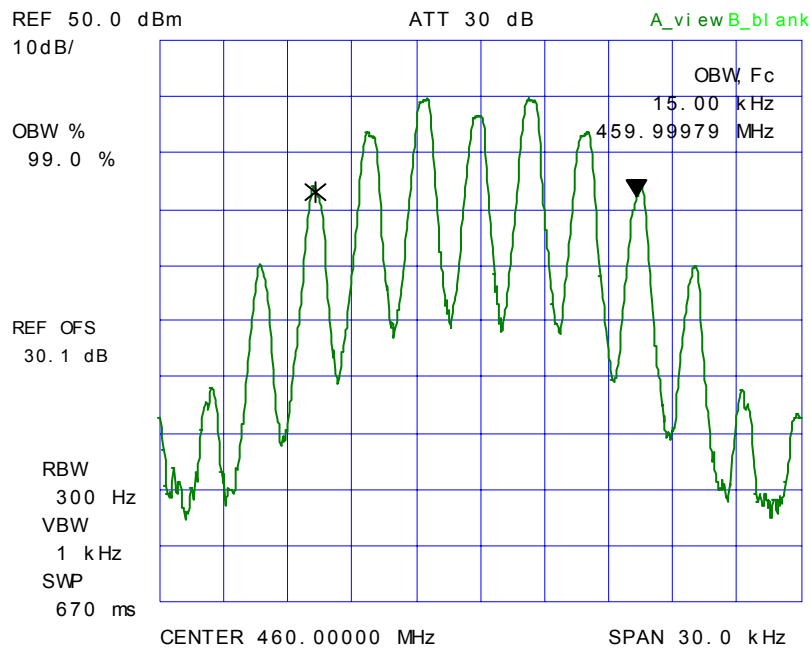

PLOT # 11 **99% Occupied Bandwidth**
Frequency: 460 MHz, 12.5 kHz Channel Spacing
Modulation: C4FM digital modulation

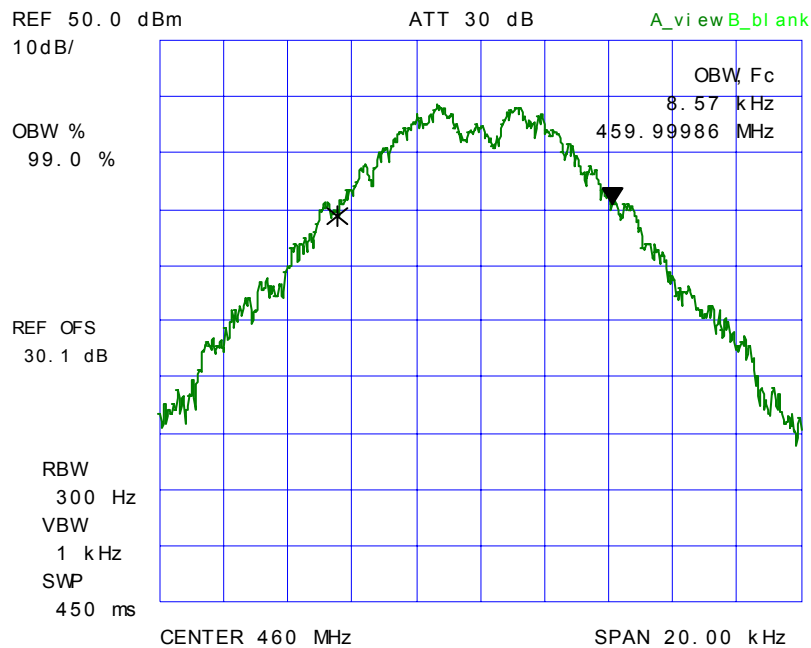

PLOT # 12 **99% Occupied Bandwidth**
Frequency: 460 MHz, 25 kHz Channel Spacing
Modulation: C4FM digital modulation

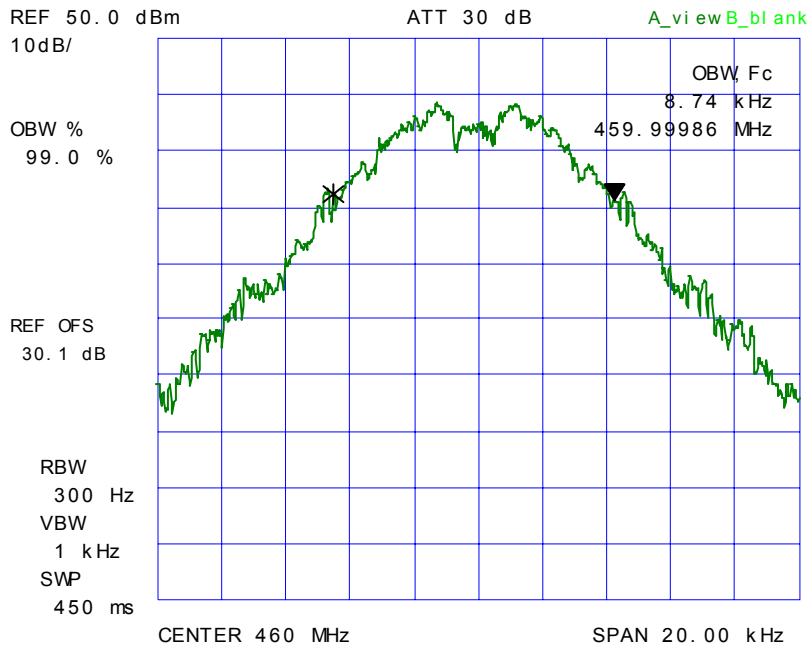

PLOT # 13 **99% Occupied Bandwidth**
Frequency: 491 MHz, 12.5 kHz Channel Spacing
Modulation: FM modulation with 2.5 kHz sine wave signal

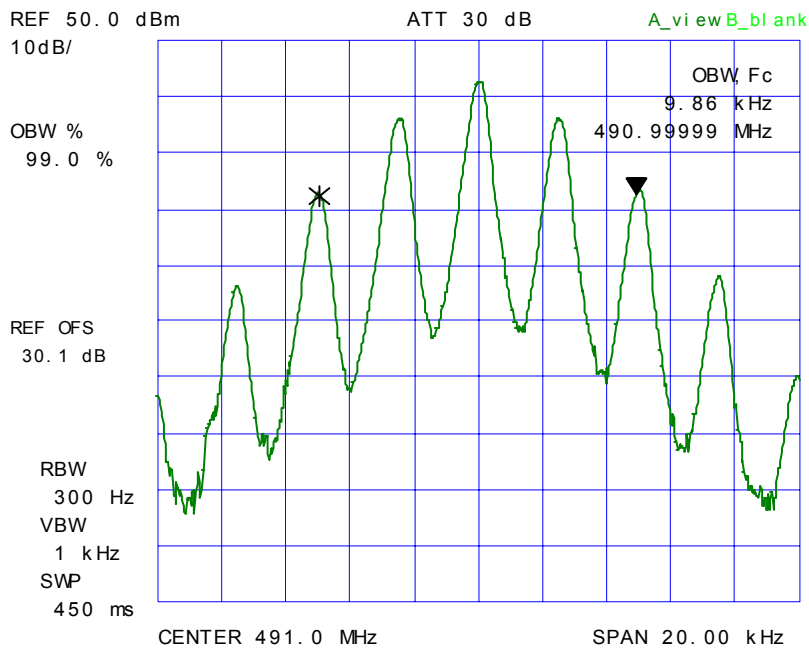

PLOT # 14 **99% Occupied Bandwidth**
Frequency: 491 MHz, 25 kHz Channel Spacing
Modulation: FM modulation with 2.5 kHz sine wave signal

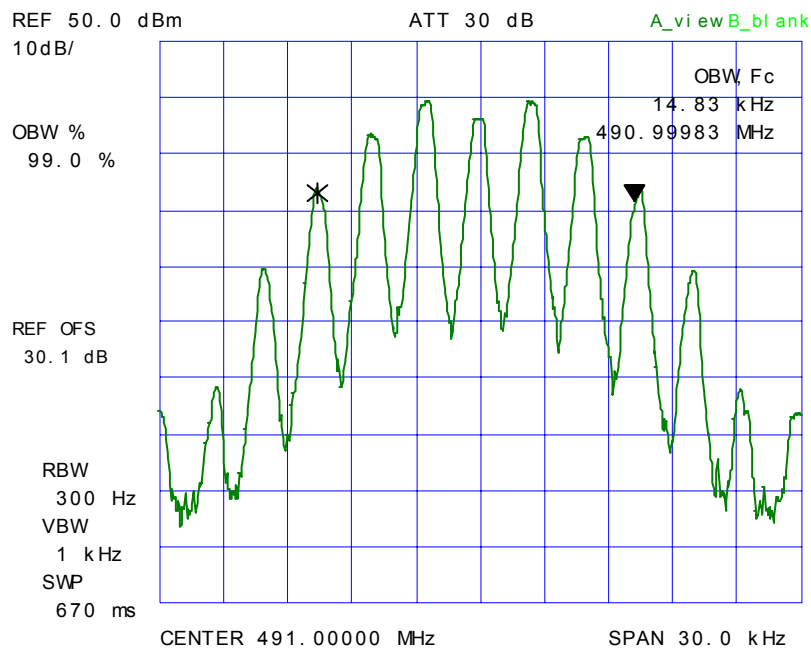

PLOT # 15 **99% Occupied Bandwidth**
Frequency: 491 MHz, 12.5 kHz Channel Spacing
Modulation: C4FM digital modulation

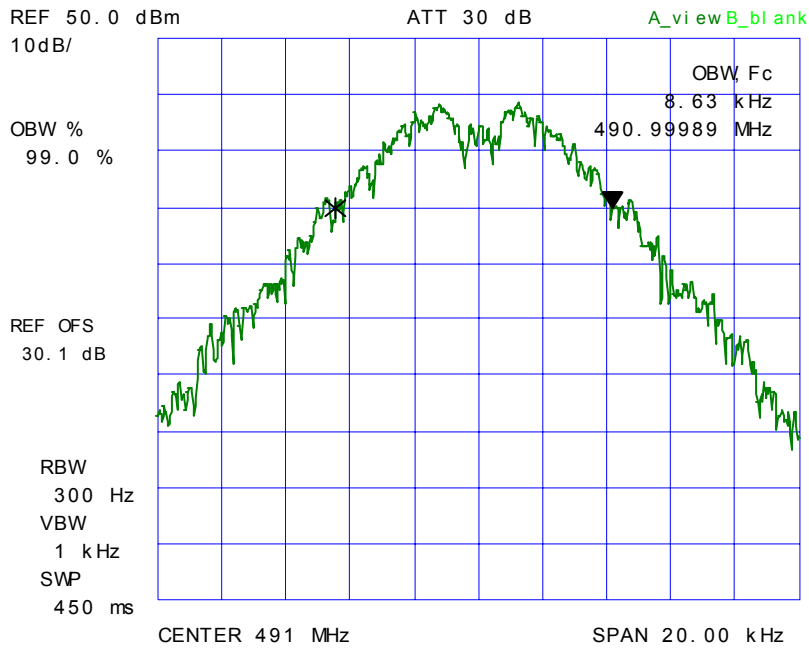

PLOT # 16 **99% Occupied Bandwidth**
Frequency: 491 MHz, 25 kHz Channel Spacing
Modulation: C4FM digital modulation

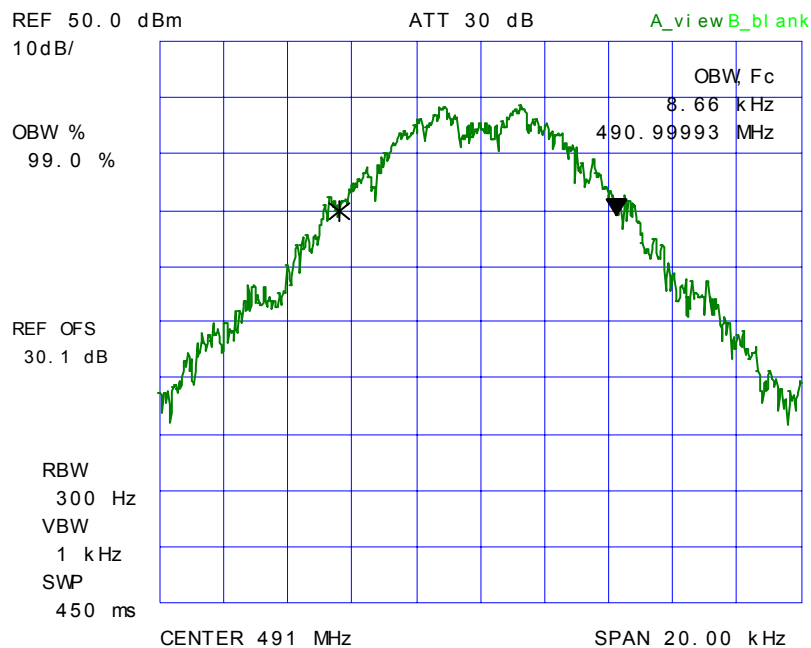

5.10.4.2. 99% Occupied Bandwidth Measurements

Remark: 99% OBW of the RF input and RF output signals were measured for comparison

5.10.4.2.1. Frequency: 380 MHz

EUT's Subband (MHz)	Channel Spacing (kHz)	Modulation	RF IN Measured 99% OBW (kHz)	RF OUT Measured 99% OBW (kHz)
380	12.5	FM with 2.5 kHz Sine wave signal	10.1	10.0
380	25.0	FM with 2.5 kHz Sine wave signal	15.0	14.9
380	12.5	Digital	8.5	8.2
380	25.0	Digital	8.5	8.2

5.10.4.2.2. Frequency: 391.5 MHz

EUT's Subband (MHz)	Channel Spacing (kHz)	Modulation	RF IN Measured 99% OBW (kHz)	RF OUT Measured 99% OBW (kHz)
391.5	12.5	FM with 2.5 kHz Sine wave signal	10.0	9.9
391.5	25.0	FM with 2.5 kHz Sine wave signal	15.2	15.2
391.5	12.5	Digital	8.3	8.2
391.5	25.0	Digital	8.2	8.3

5.10.4.2.3. Frequency: 403 MHz

EUT's Subband (MHz)	Channel Spacing (kHz)	Modulation	RF IN Measured 99% OBW (kHz)	RF OUT Measured 99% OBW (kHz)
403	12.5	FM with 2.5 kHz Sine wave signal	10.1	9.9
403	25.0	FM with 2.5 kHz Sine wave signal	15.2	15.2
403	12.5	Digital	8.5	8.1
403	25.0	Digital	8.4	8.3

5.10.4.2.4. Frequency: 406.1 MHz

EUT's Subband (MHz)	Channel Spacing (kHz)	Modulation	RF IN Measured 99% OBW (kHz)	RF OUT Measured 99% OBW (kHz)
406.1	12.5	FM with 2.5 kHz Sine wave signal	10.1	9.9
406.1	25.0	FM with 2.5 kHz Sine wave signal	15.0	14.9
406.1	12.5	Digital	8.5	8.2
406.1	25.0	Digital	8.6	8.3

5.10.4.2.5. Frequency: 418.05 MHz

EUT's Subband (MHz)	Channel Spacing (kHz)	Modulation	RF IN Measured 99% OBW (kHz)	RF OUT Measured 99% OBW (kHz)
418.05	12.5	FM with 2.5 kHz Sine wave signal	10.1	9.9
418.05	25.0	FM with 2.5 kHz Sine wave signal	15.2	15.1
418.05	12.5	Digital	8.3	8.2
418.05	25.0	Digital	8.6	8.3

5.10.4.2.6. Frequency: 430 MHz

EUT's Subband (MHz)	Channel Spacing (kHz)	Modulation	RF IN Measured 99% OBW (kHz)	RF OUT Measured 99% OBW (kHz)
430	12.5	FM with 2.5 kHz Sine wave signal	10.1	10.0
430	25.0	FM with 2.5 kHz Sine wave signal	15.2	15.1
430	12.5	Digital	8.5	8.2
430	25.0	Digital	8.6	8.3

5.10.4.2.7. Frequency: 450 MHz

EUT's Subband (MHz)	Channel Spacing (kHz)	Modulation	RF IN Measured 99% OBW (kHz)	RF OUT Measured 99% OBW (kHz)
450	12.5	FM with 2.5 kHz Sine wave signal	10.0	9.9
450	25.0	FM with 2.5 kHz Sine wave signal	15.2	15.1
450	12.5	Digital	8.3	8.1
450	25.0	Digital	8.5	8.2

5.10.4.2.8. Frequency: 460 MHz

EUT's Subband (MHz)	Channel Spacing (kHz)	Modulation	RF IN Measured 99% OBW (kHz)	RF OUT Measured 99% OBW (kHz)
460	12.5	FM with 2.5 kHz Sine wave signal	10.1	10.0
460	25.0	FM with 2.5 kHz Sine wave signal	15.3	15.1
460	12.5	Digital	8.4	8.2
460	25.0	Digital	8.4	8.3

5.10.4.2.9. Frequency: 470 MHz

EUT's Subband (MHz)	Channel Spacing (kHz)	Modulation	RF IN Measured 99% OBW (kHz)	RF OUT Measured 99% OBW (kHz)
470	12.5	FM with 2.5 kHz Sine wave signal	10.1	10.0
470	25.0	FM with 2.5 kHz Sine wave signal	15.0	14.9
470	12.5	Digital	8.5	8.3
470	25.0	Digital	8.4	8.4

5.10.4.2.10. Frequency: 470 MHz

EUT's Subband (MHz)	Channel Spacing (kHz)	Modulation	RF IN Measured 99% OBW (kHz)	RF OUT Measured 99% OBW (kHz)
470	12.5	FM with 2.5 kHz Sine wave signal	10.1	10.0
470	25.0	FM with 2.5 kHz Sine wave signal	15.0	14.9
470	12.5	Digital	8.5	8.1
470	25.0	Digital	8.4	8.3

5.10.4.2.11. Frequency: 491 MHz

EUT's Subband (MHz)	Channel Spacing (kHz)	Modulation	RF IN Measured 99% OBW (kHz)	RF OUT Measured 99% OBW (kHz)
491	12.5	FM with 2.5 kHz Sine wave signal	10.1	10.0
491	25.0	FM with 2.5 kHz Sine wave signal	15.1	15.0
491	12.5	Digital	8.5	8.2
491	25.0	Digital	8.3	8.3

5.10.4.2.12. Frequency: 512 MHz

EUT's Subband (MHz)	Channel Spacing (kHz)	Modulation	RF IN Measured 99% OBW (kHz)	RF OUT Measured 99% OBW (kHz)
512	12.5	FM with 2.5 kHz Sine wave signal	10.1	10.1
512	25.0	FM with 2.5 kHz Sine wave signal	15.1	15.0
512	12.5	Digital	8.7	8.2
512	25.0	Digital	8.3	8.5

PLOT # 17 99% Occupied Bandwidth – RF Input Signal
Frequency: 380.0 MHz, 12.5 kHz Channel Spacing
Modulation: FM modulation with 2.5 kHz Sine wave signal

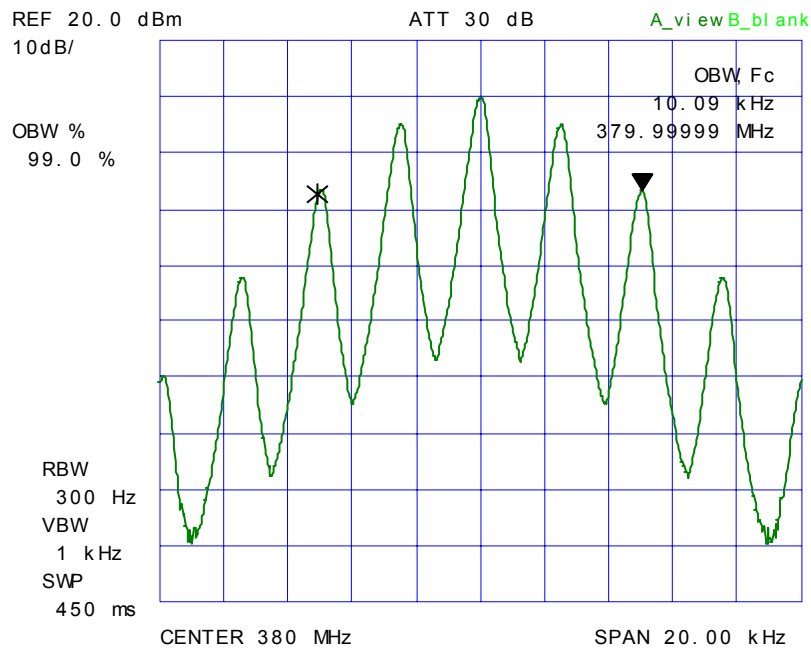

PLOT # 18 99% Occupied Bandwidth – RF Output Signal
Frequency: 380.0 MHz, 12.5 kHz Channel Spacing
Modulation: FM modulation with 2.5 kHz Sine wave signal

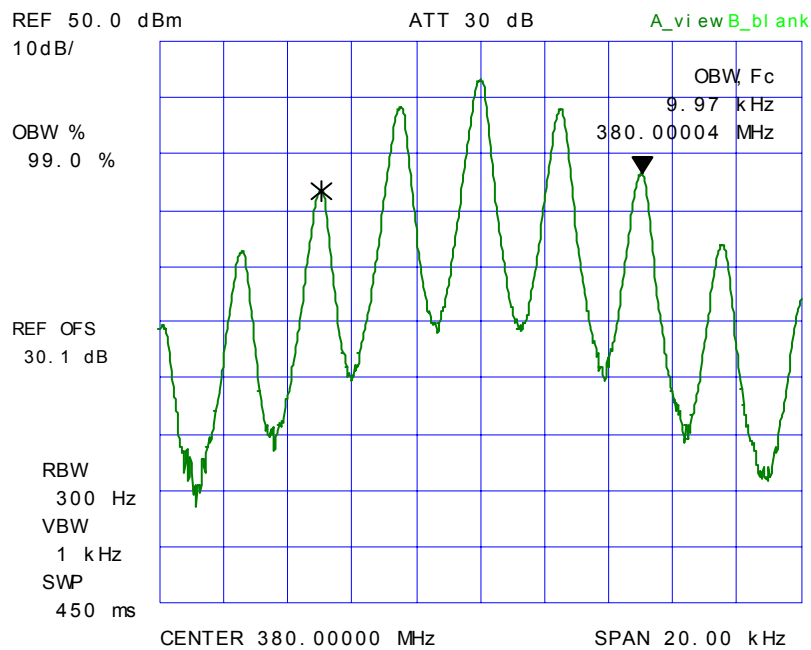

PLOT # 19 99% Occupied Bandwidth – RF Input Signal
Frequency: 380.0 MHz, 25 kHz Channel Spacing
Modulation: FM modulation with 5 kHz Sine wave signal

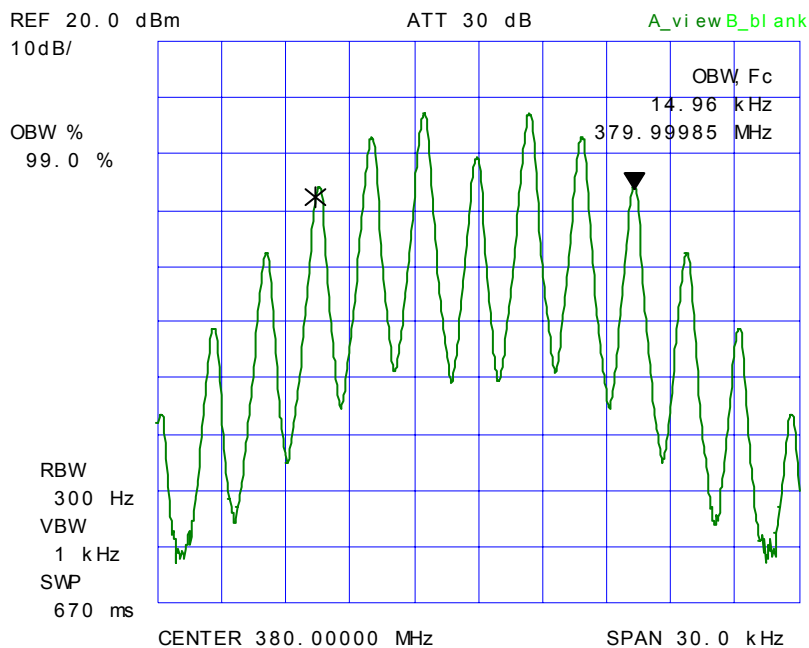

PLOT # 20 99% Occupied Bandwidth – RF Output Signal
Frequency: 380.0 MHz, 25 kHz Channel Spacing
Modulation: FM modulation with 5 kHz Sine wave signal

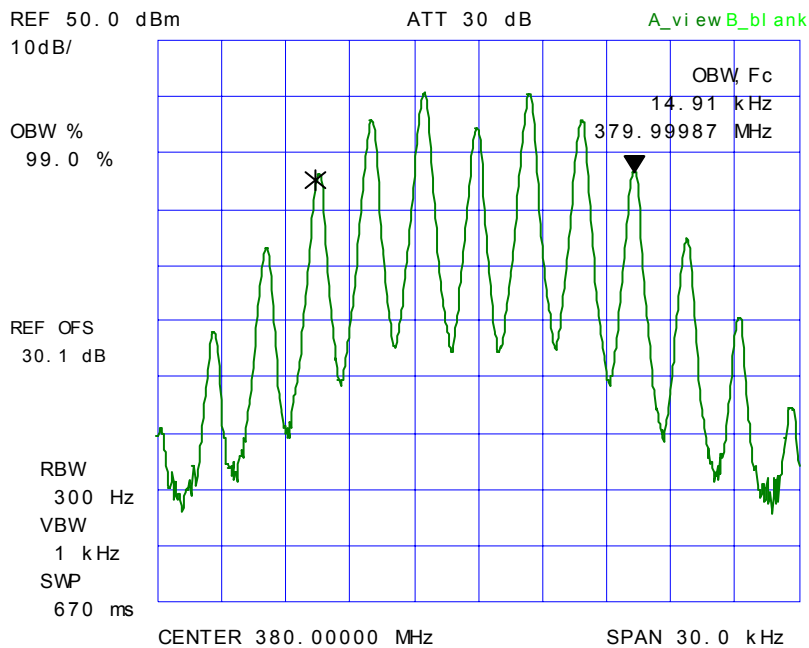

PLOT # 21 99% Occupied Bandwidth – RF Input Signal
Frequency: 380.0 MHz, 12.5 kHz Channel Spacing
Modulation: Digital

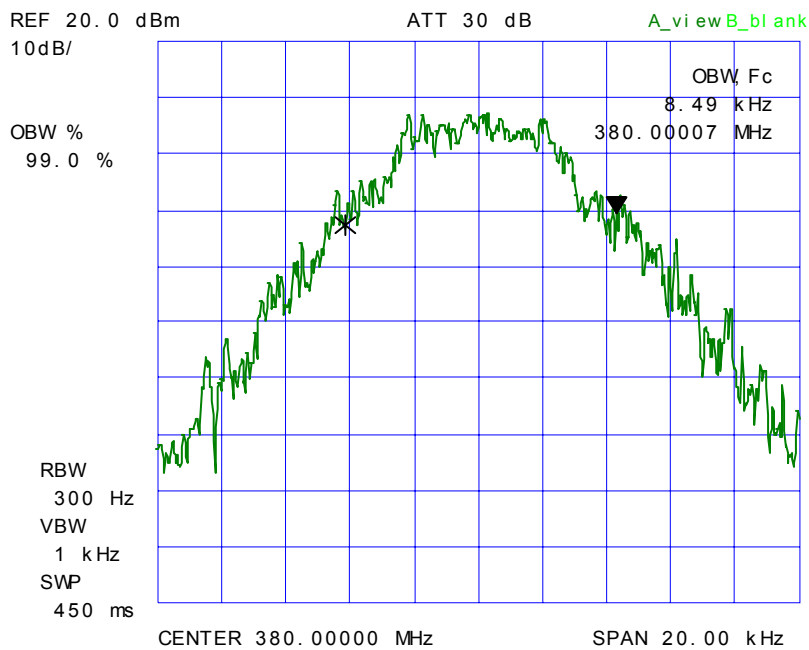

PLOT # 22 99% Occupied Bandwidth – RF Output Signal
Frequency: 380.0 MHz, 12.5 kHz Channel Spacing
Modulation: Digital

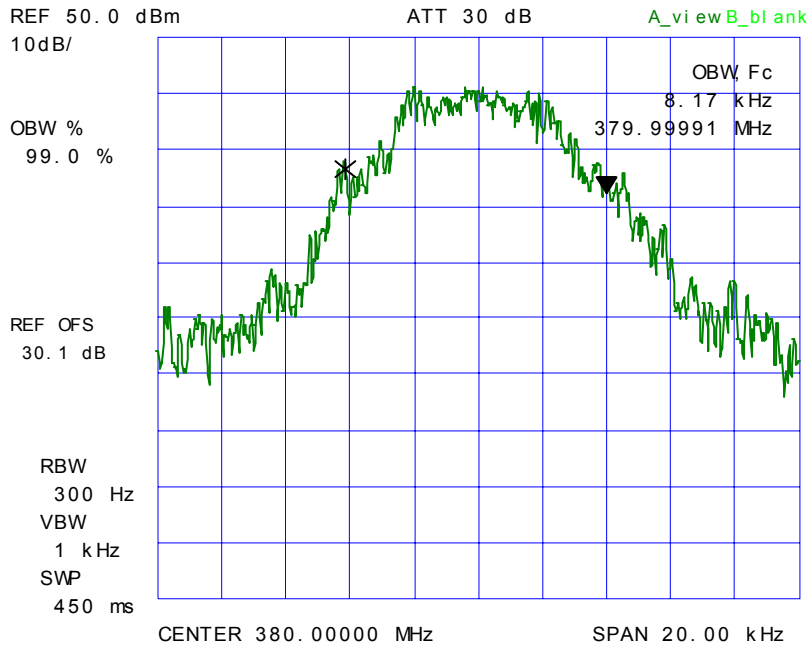

PLOT # 23 99% Occupied Bandwidth – RF Input Signal
Frequency: 380.0 MHz, 25 kHz Channel Spacing
Modulation: Digital

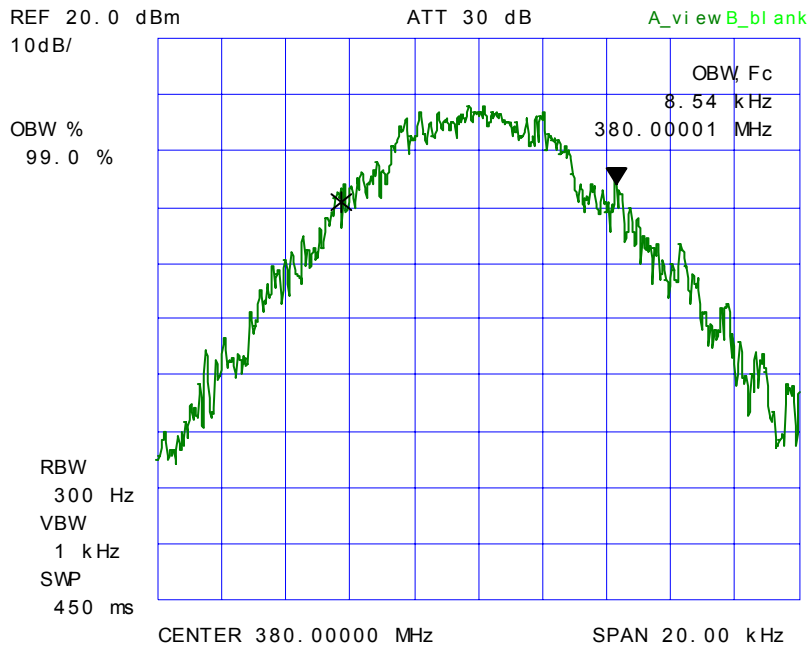

PLOT # 24 99% Occupied Bandwidth – RF Output Signal
Frequency: 380.0 MHz, 25 kHz Channel Spacing
Modulation: Digital

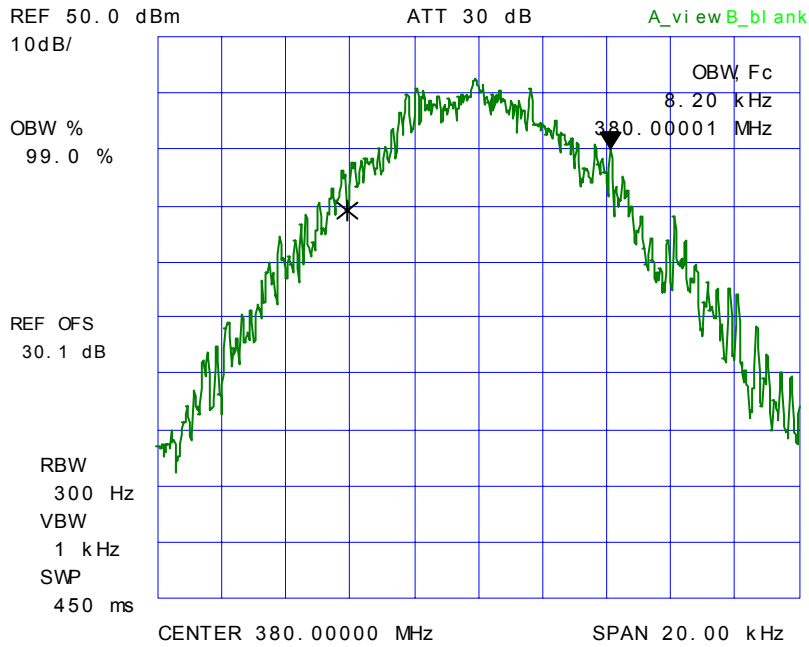

PLOT # 25 99% Occupied Bandwidth – RF Input Signal
Frequency: 391.5 MHz, 12.5 kHz Channel Spacing
Modulation: FM modulation with 2.5 kHz Sine wave signal

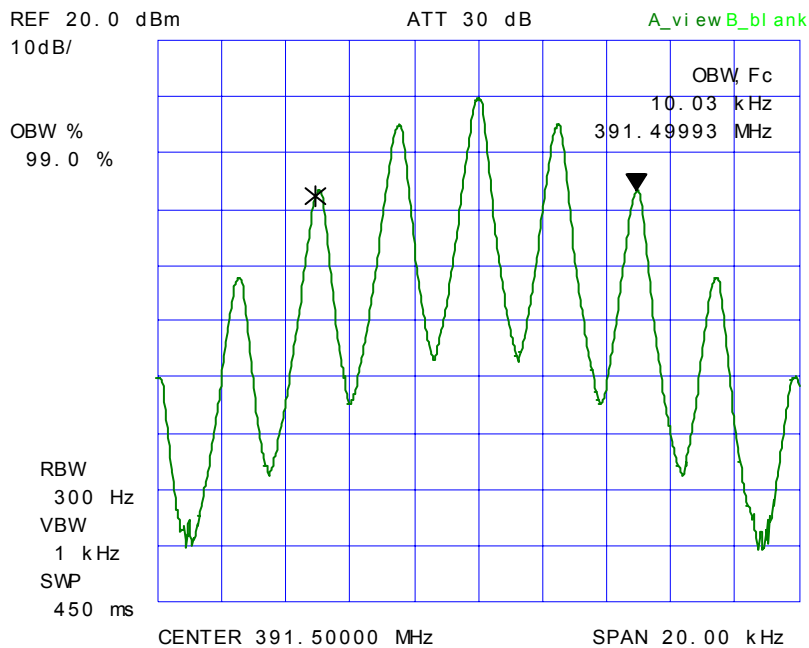

PLOT # 26 99% Occupied Bandwidth – RF Output Signal
Frequency: 391.5 MHz, 12.5 kHz Channel Spacing
Modulation: FM modulation with 2.5 kHz Sine wave signal

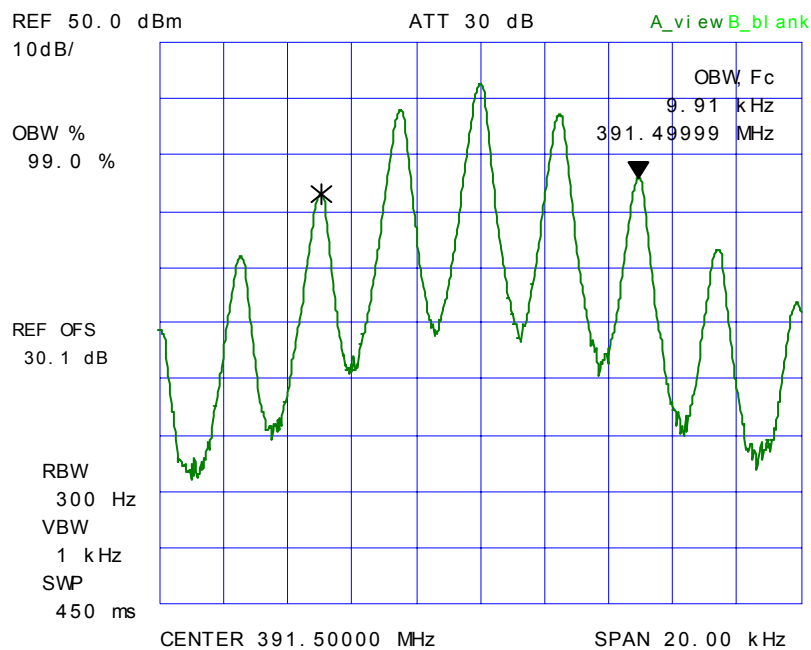

PLOT # 27 99% Occupied Bandwidth – RF Input Signal
Frequency: 391.5 MHz, 25 kHz Channel Spacing
Modulation: FM modulation with 5 kHz Sine wave signal

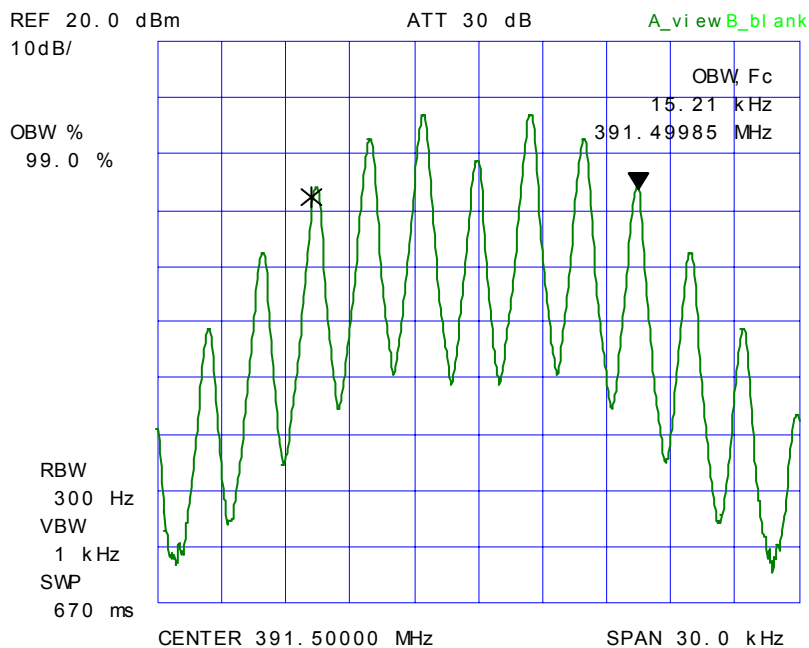

PLOT # 28 99% Occupied Bandwidth – RF Output Signal
Frequency: 391.5 MHz, 25 kHz Channel Spacing
Modulation: FM modulation with 5 kHz Sine wave signal

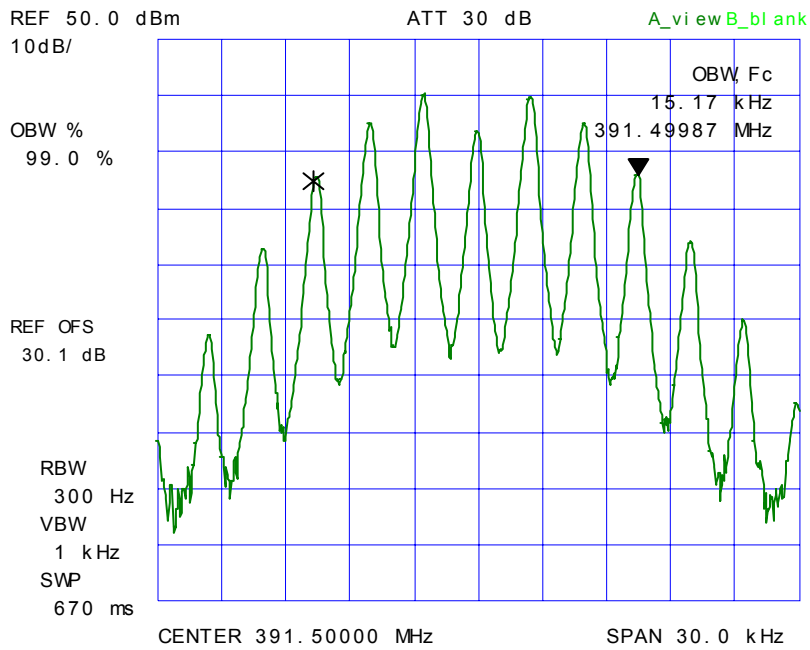

PLOT # 29 99% Occupied Bandwidth – RF Input Signal
Frequency: 391.5 MHz, 12.5 kHz Channel Spacing
Modulation: Digital

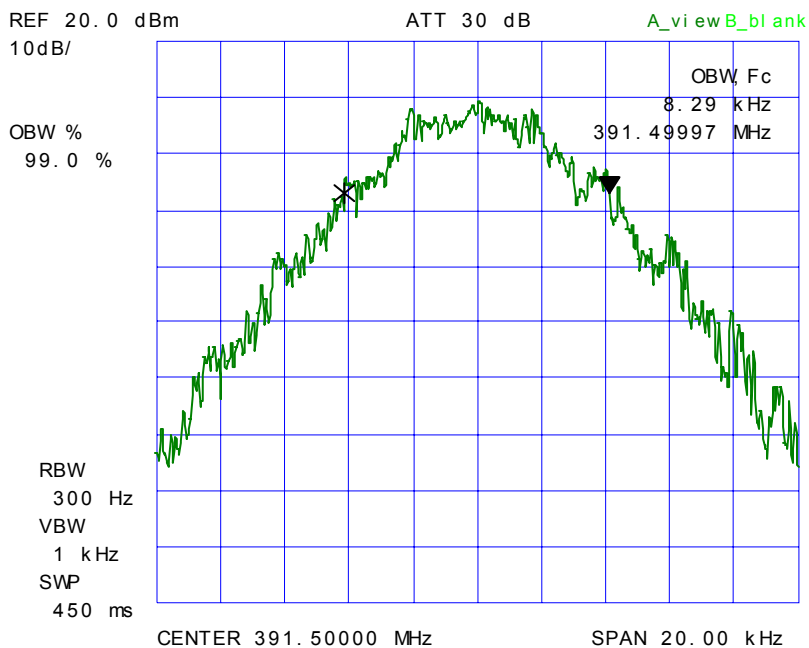

PLOT # 30 99% Occupied Bandwidth – RF Output Signal
Frequency: 391.5 MHz, 12.5 kHz Channel Spacing
Modulation: Digital

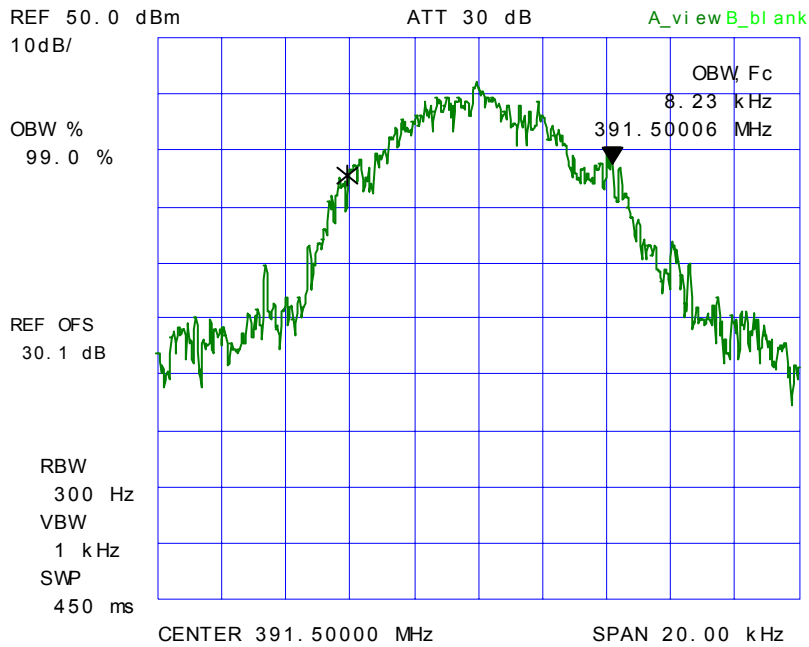

PLOT # 31 99% Occupied Bandwidth – RF Input Signal
Frequency: 391.5 MHz, 25 kHz Channel Spacing
Modulation: Digital

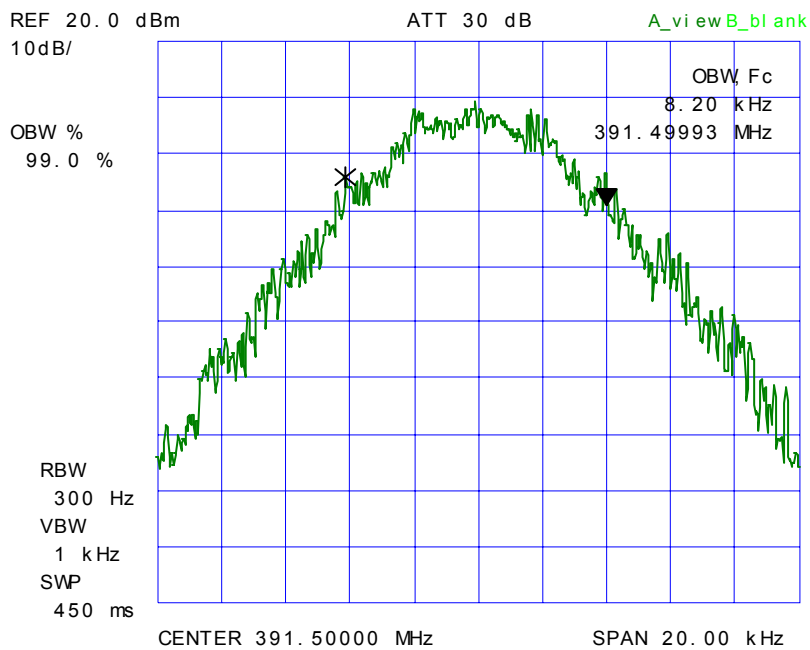

PLOT # 32 99% Occupied Bandwidth – RF Output Signal
Frequency: 391.5 MHz, 25 kHz Channel Spacing
Modulation: Digital

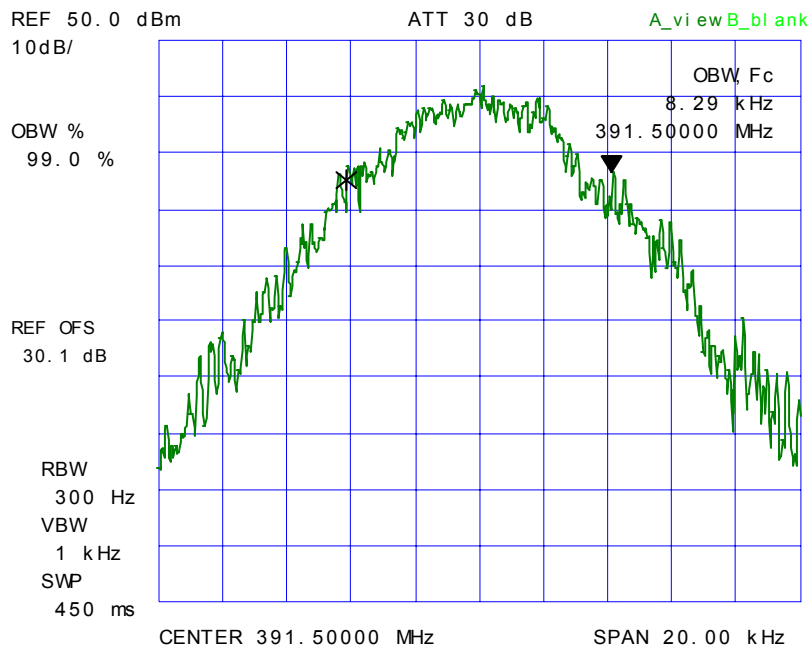

PLOT # 33 99% Occupied Bandwidth – RF Input Signal
Frequency: 403 MHz, 12.5 kHz Channel Spacing
Modulation: FM modulation with 2.5 kHz Sine wave signal

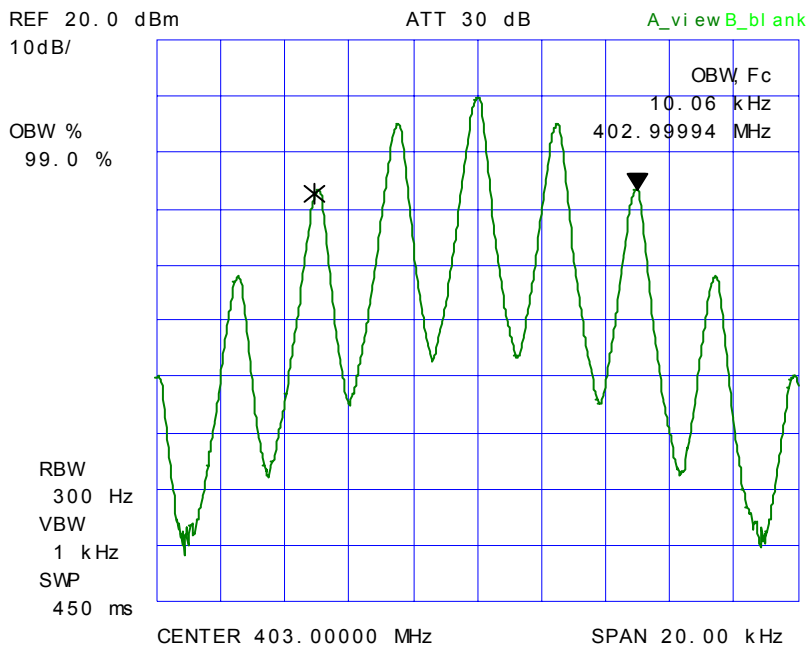

PLOT # 34 99% Occupied Bandwidth – RF Output Signal
Frequency: 403 MHz, 12.5 kHz Channel Spacing
Modulation: FM modulation with 2.5 kHz Sine wave signal

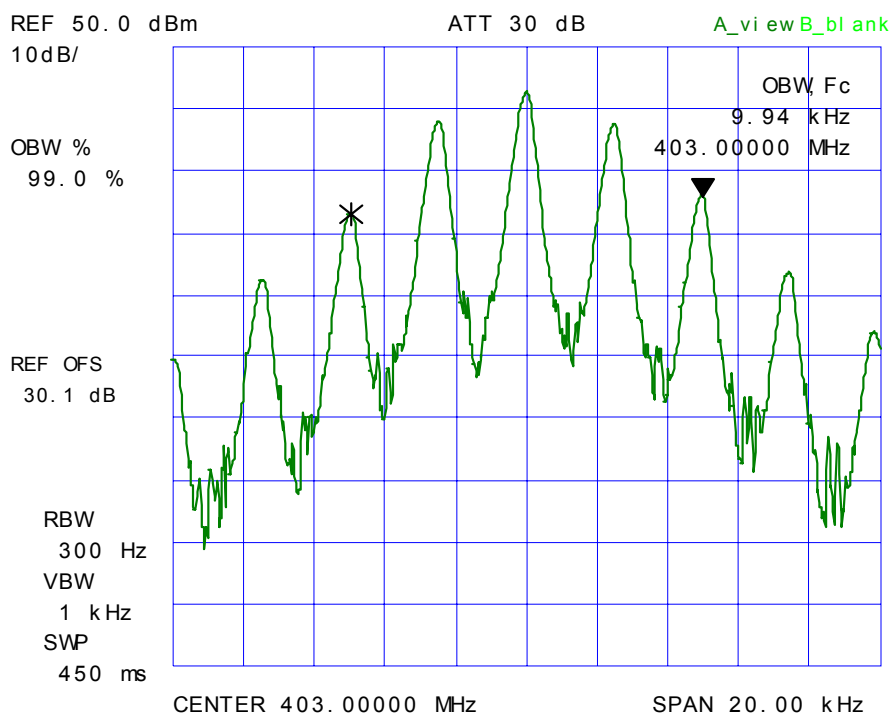

PLOT # 35 99% Occupied Bandwidth – RF Input Signal
Frequency: 403 MHz, 25 kHz Channel Spacing
Modulation: FM modulation with 5 kHz Sine wave signal

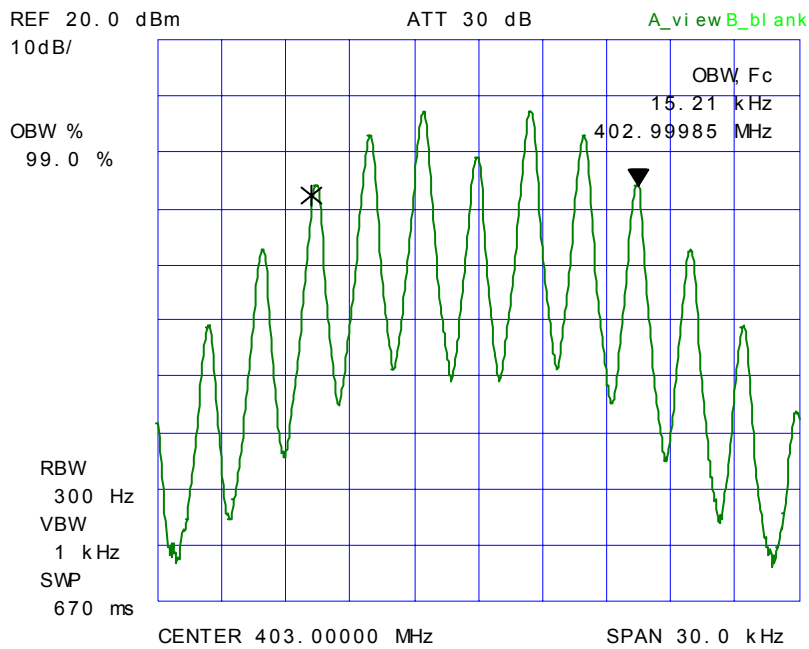

PLOT # 36 99% Occupied Bandwidth – RF Output Signal
Frequency: 403 MHz, 25 kHz Channel Spacing
Modulation: FM modulation with 5 kHz Sine wave signal

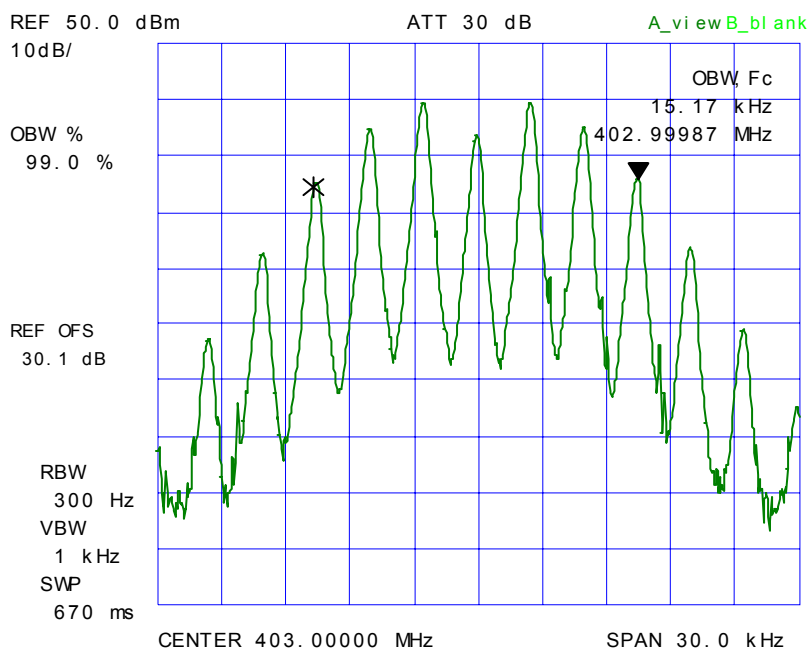

PLOT # 37 99% Occupied Bandwidth – RF Input Signal
Frequency: 403 MHz, 12.5 kHz Channel Spacing
Modulation: Digital

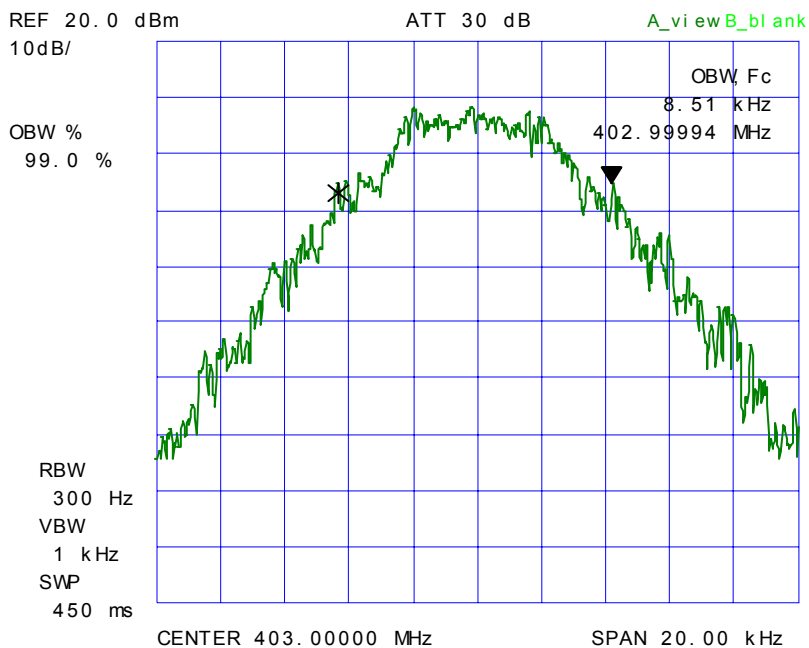

PLOT # 38 99% Occupied Bandwidth – RF Output Signal
Frequency: 403 MHz, 12.5 kHz Channel Spacing
Modulation: Digital

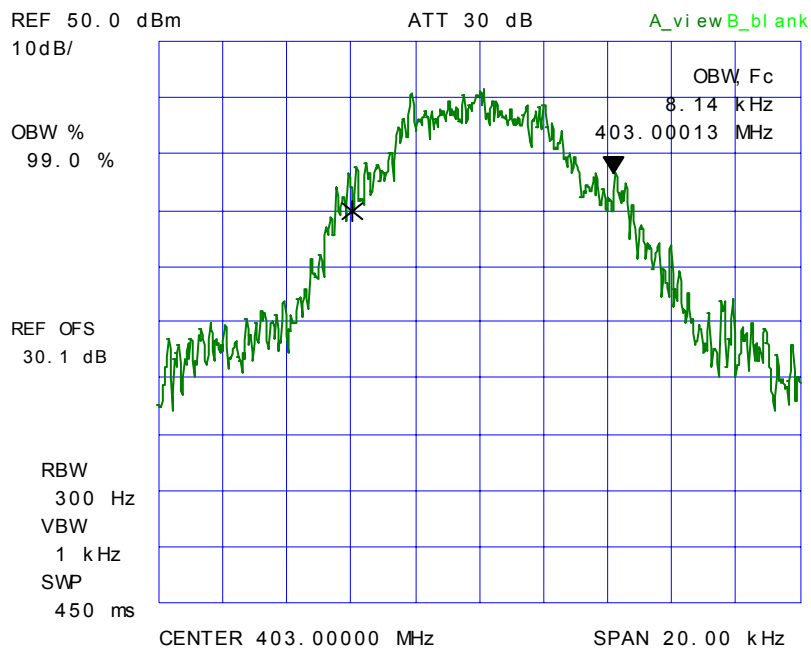

PLOT # 39 99% Occupied Bandwidth – RF Input Signal
Frequency: 403 MHz, 25 kHz Channel Spacing
Modulation: Digital

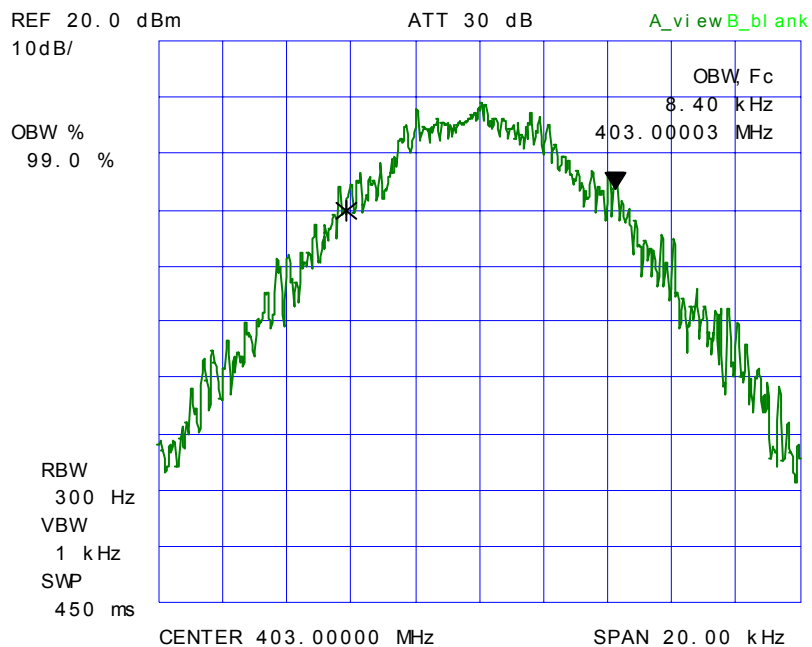

PLOT # 40 99% Occupied Bandwidth – RF Output Signal
Frequency: 403 MHz, 25 kHz Channel Spacing
Modulation: Digital

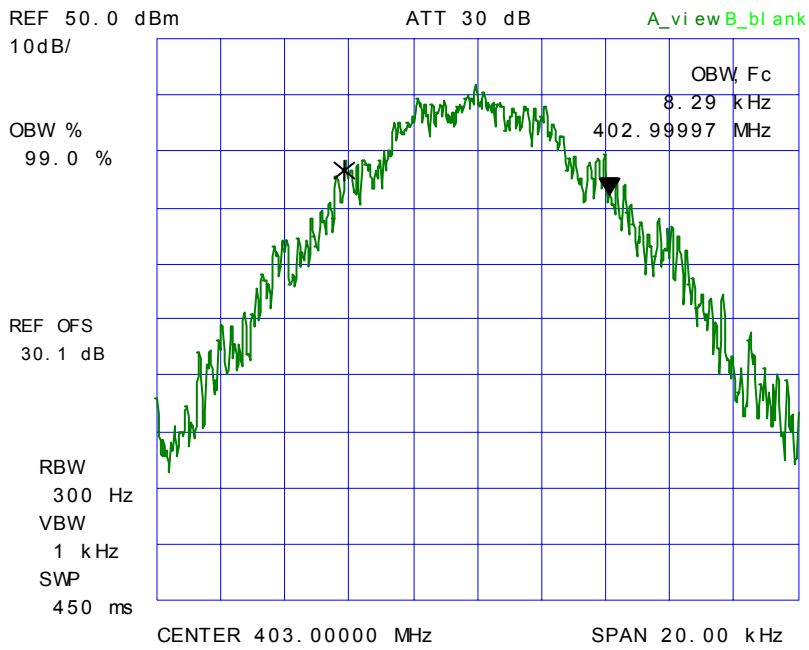

PLOT # 41 99% Occupied Bandwidth – RF Input Signal
Frequency: 406.1MHz, 12.5 kHz Channel Spacing
Modulation: FM modulation with 2.5 kHz Sine wave signal

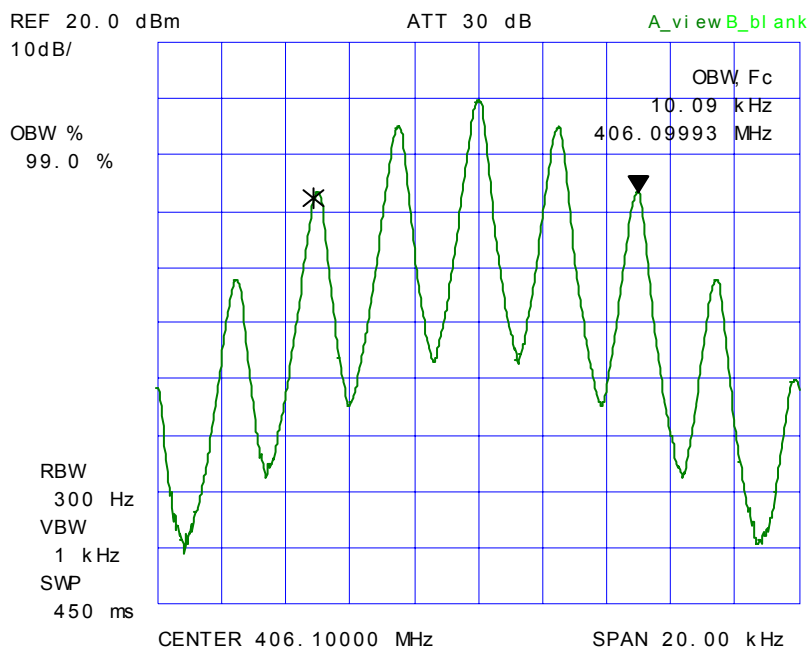

PLOT # 42 99% Occupied Bandwidth – RF Output Signal
Frequency: 406.1MHz, 12.5 kHz Channel Spacing
Modulation: FM modulation with 2.5 kHz Sine wave signal

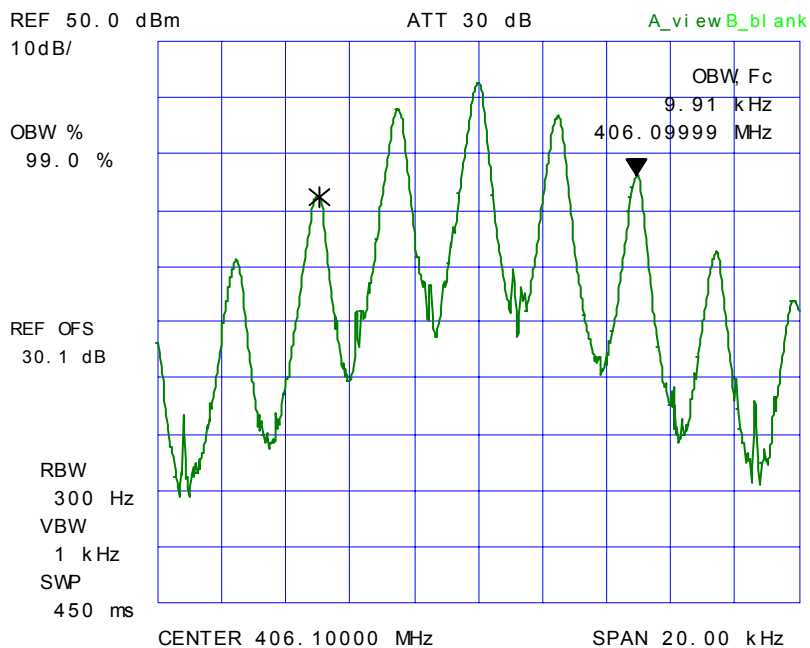

PLOT # 43 99% Occupied Bandwidth – RF Input Signal
Frequency: 406.1MHz, 25 kHz Channel Spacing
Modulation: FM modulation with 5 kHz Sine wave signal

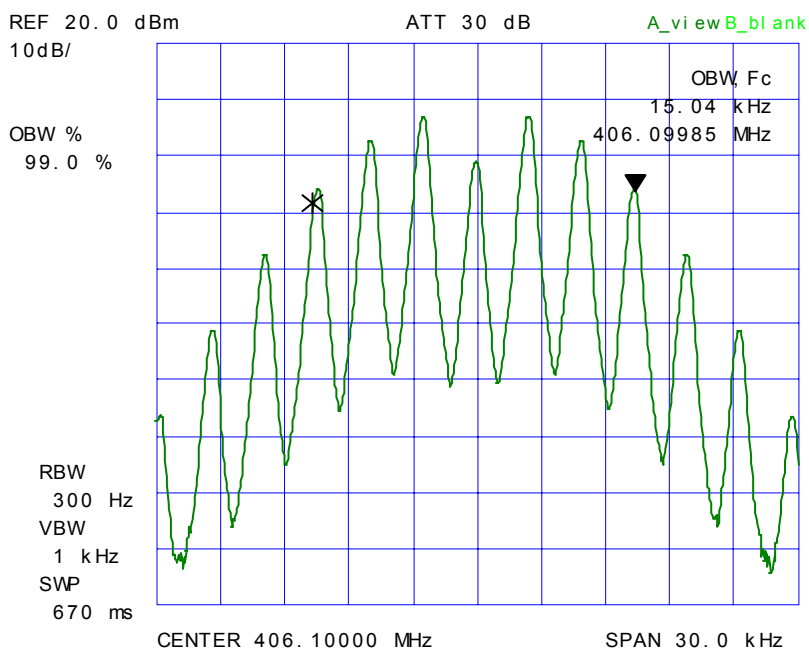

PLOT # 44 99% Occupied Bandwidth – RF Output Signal
Frequency: 406.1MHz, 25 kHz Channel Spacing
Modulation: FM modulation with 5 kHz Sine wave signal

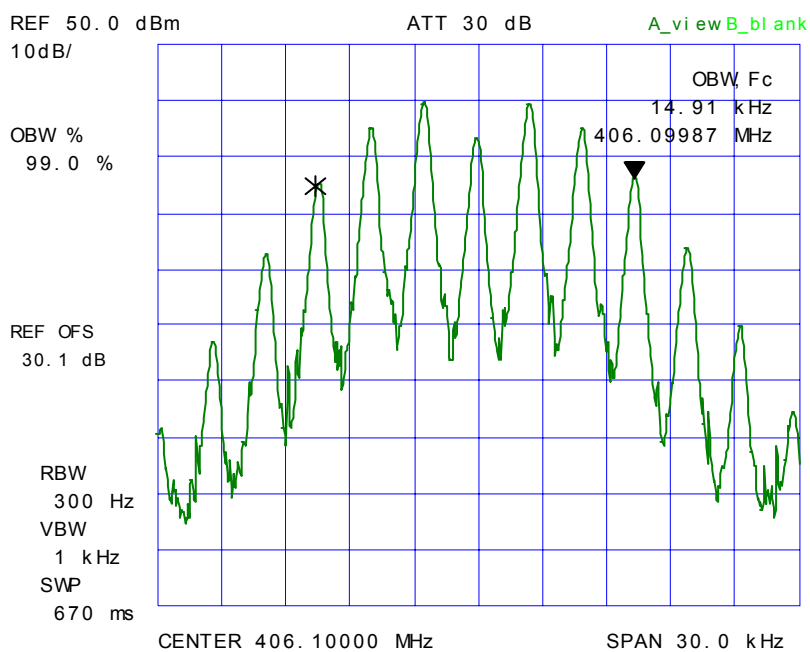

PLOT # 45 99% Occupied Bandwidth – RF Input Signal
Frequency: 406.1MHz, 12.5 kHz Channel Spacing
Modulation: Digital

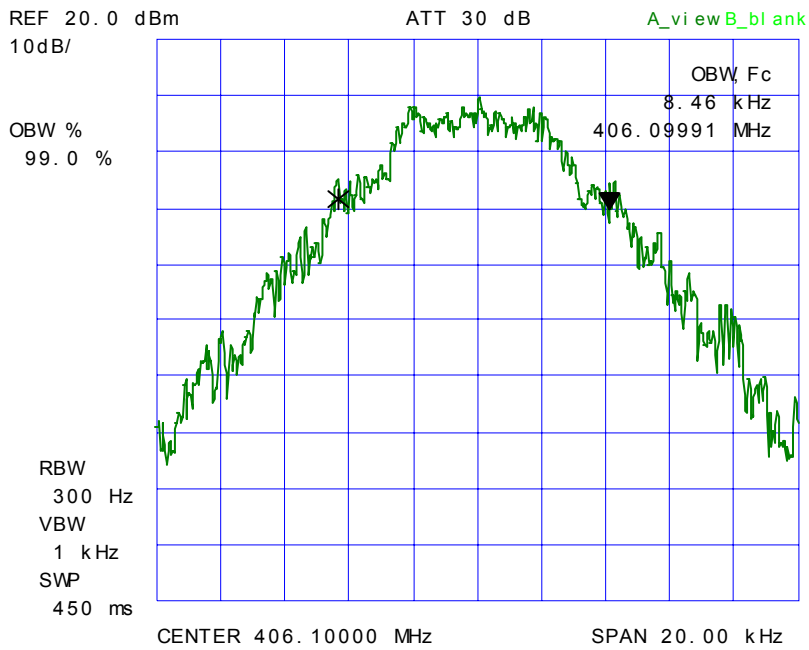

PLOT # 46 99% Occupied Bandwidth – RF Output Signal
Frequency: 406.1MHz, 12.5 kHz Channel Spacing
Modulation: Digital

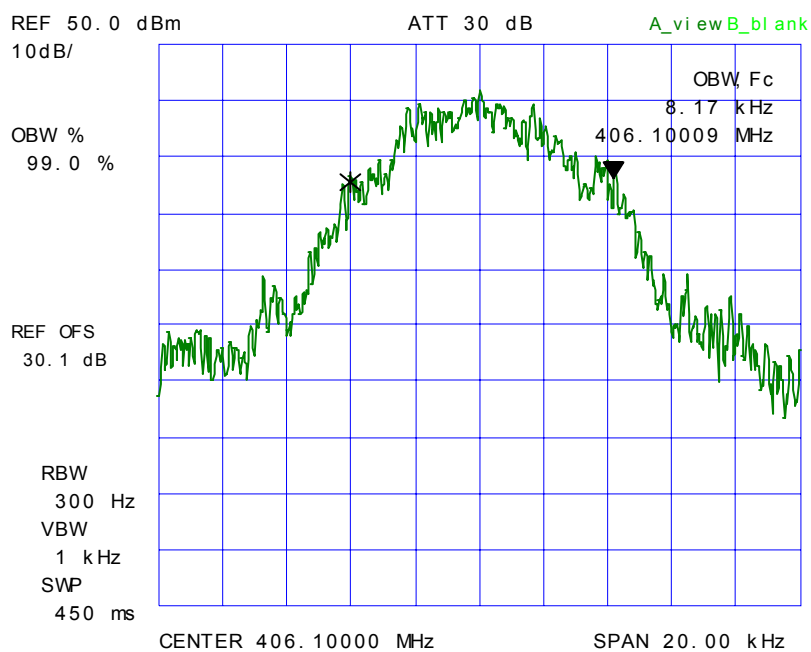

PLOT # 47 99% Occupied Bandwidth – RF Input Signal
Frequency: 406.1MHz, 25 kHz Channel Spacing
Modulation: Digital

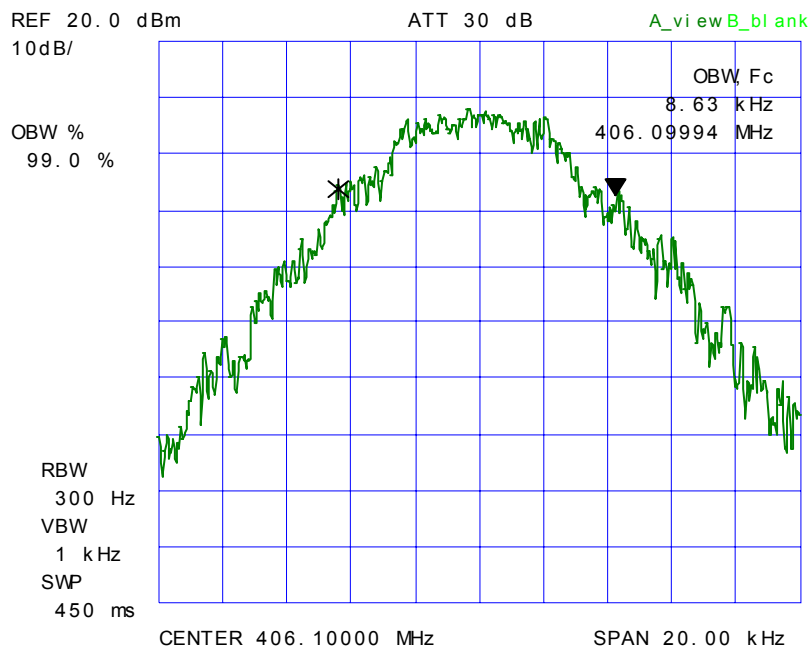

PLOT # 48 99% Occupied Bandwidth – RF Output Signal
Frequency: 406.1MHz, 25 kHz Channel Spacing
Modulation: Digital

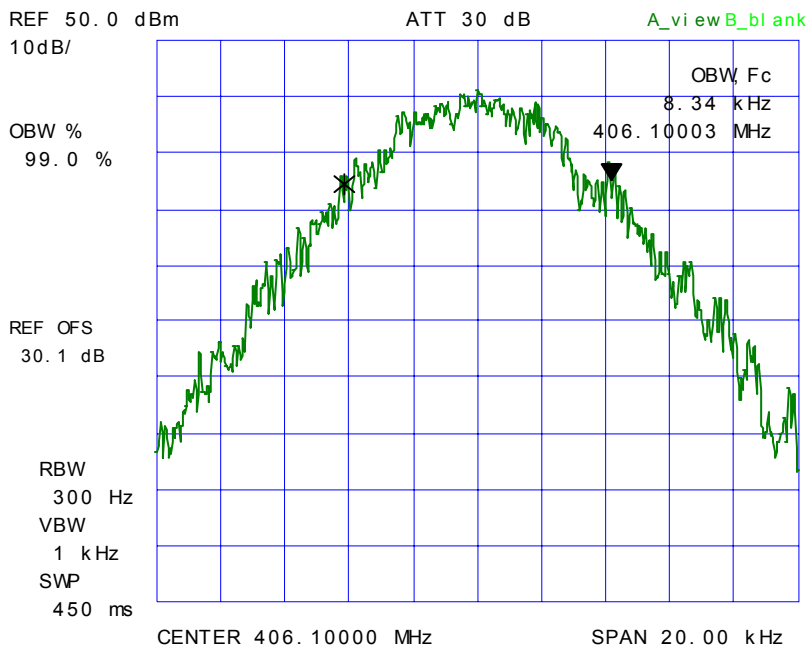

PLOT # 49 99% Occupied Bandwidth – RF Input Signal
Frequency: 418.05 MHz, 12.5 kHz Channel Spacing
Modulation: FM modulation with 2.5 kHz Sine wave signal

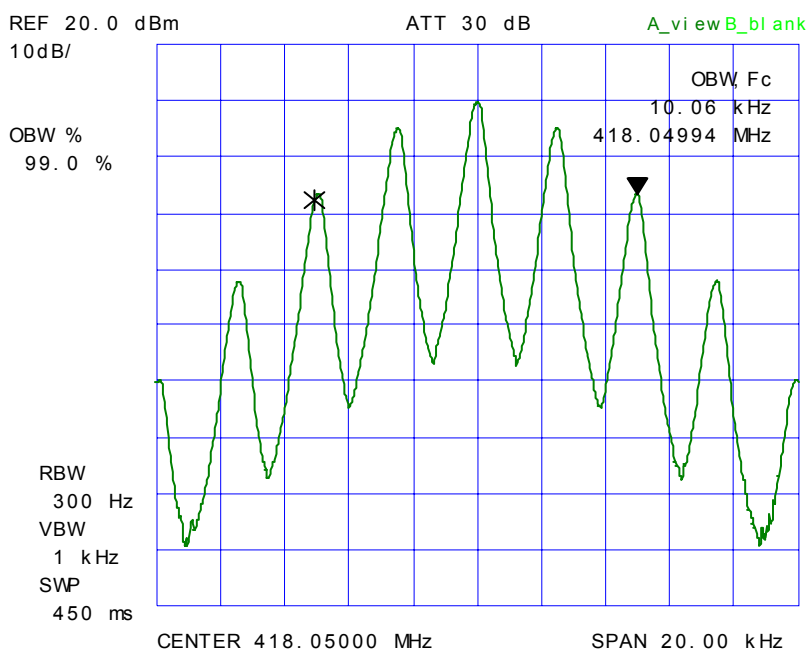

PLOT # 50 99% Occupied Bandwidth – RF Output Signal
Frequency: 418.05 MHz, 12.5 kHz Channel Spacing
Modulation: FM modulation with 2.5 kHz Sine wave signal

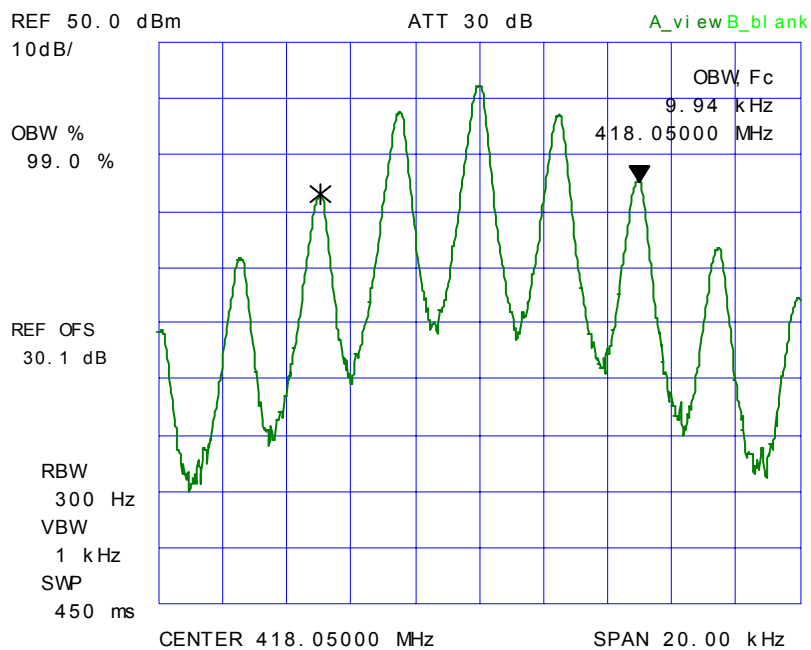

PLOT # 51 99% Occupied Bandwidth – RF Input Signal
Frequency: 418.05 MHz, 25 kHz Channel Spacing
Modulation: FM modulation with 5 kHz Sine wave signal

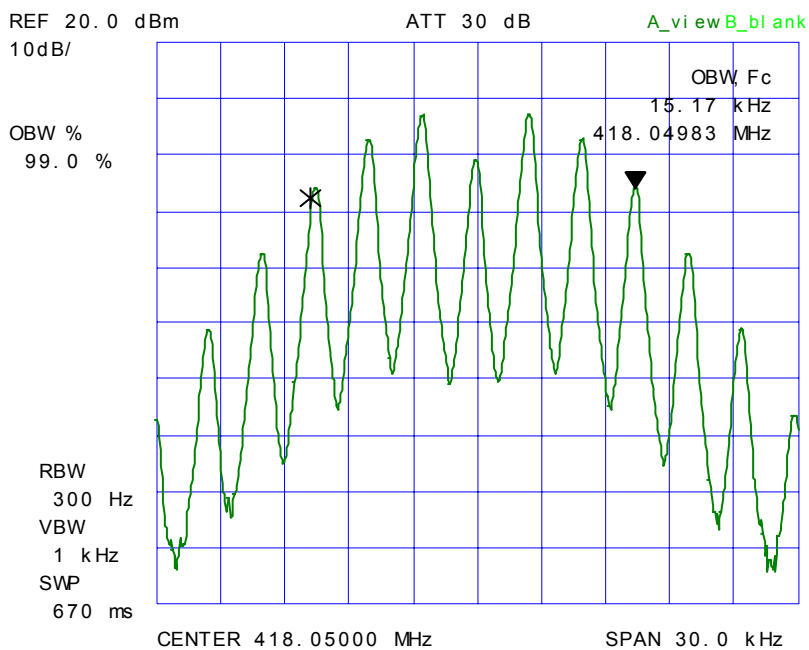

PLOT # 52 99% Occupied Bandwidth – RF Output Signal
Frequency: 418.05 MHz, 25 kHz Channel Spacing
Modulation: FM modulation with 5 kHz Sine wave signal

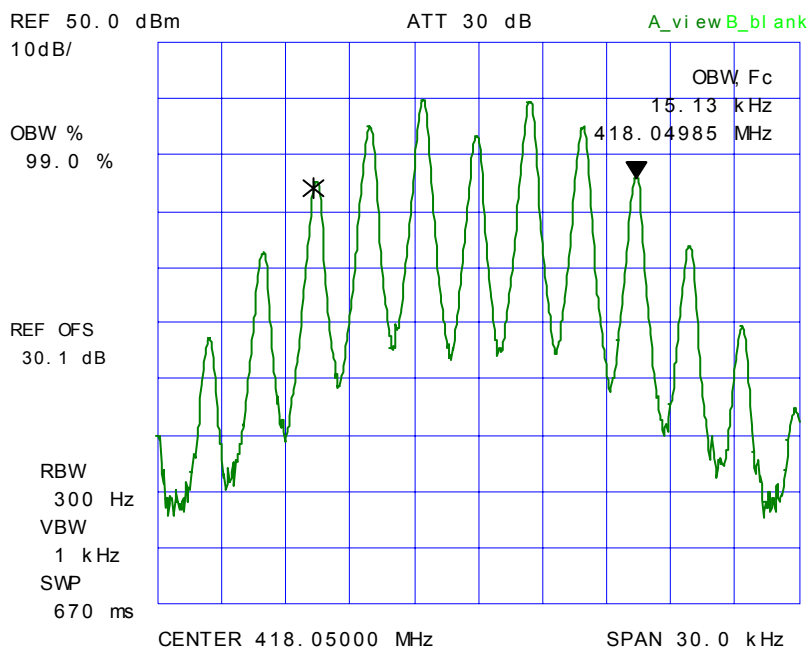

PLOT # 53 99% Occupied Bandwidth – RF Input Signal
Frequency: 418.05 MHz, 12.5 kHz Channel Spacing
Modulation: Digital

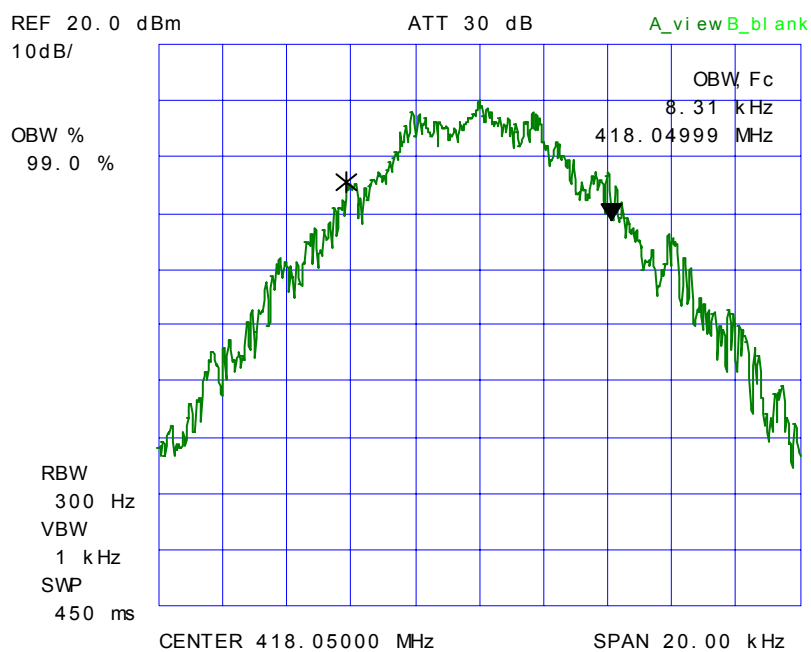

PLOT # 54 99% Occupied Bandwidth – RF Output Signal
Frequency: 418.05 MHz, 12.5 kHz Channel Spacing
Modulation: Digital

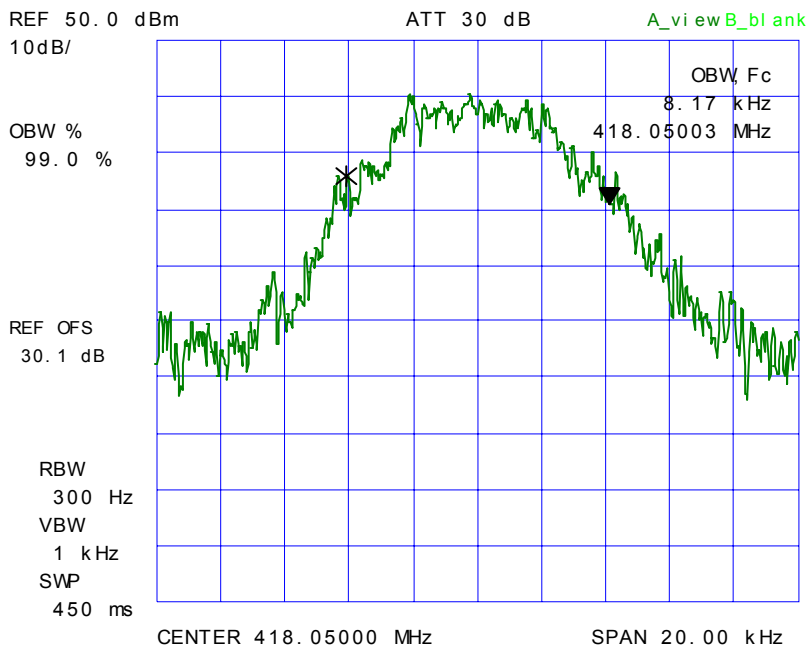

PLOT # 55 99% Occupied Bandwidth – RF Input Signal
Frequency: 418.05 MHz, 25 kHz Channel Spacing
Modulation: Digital

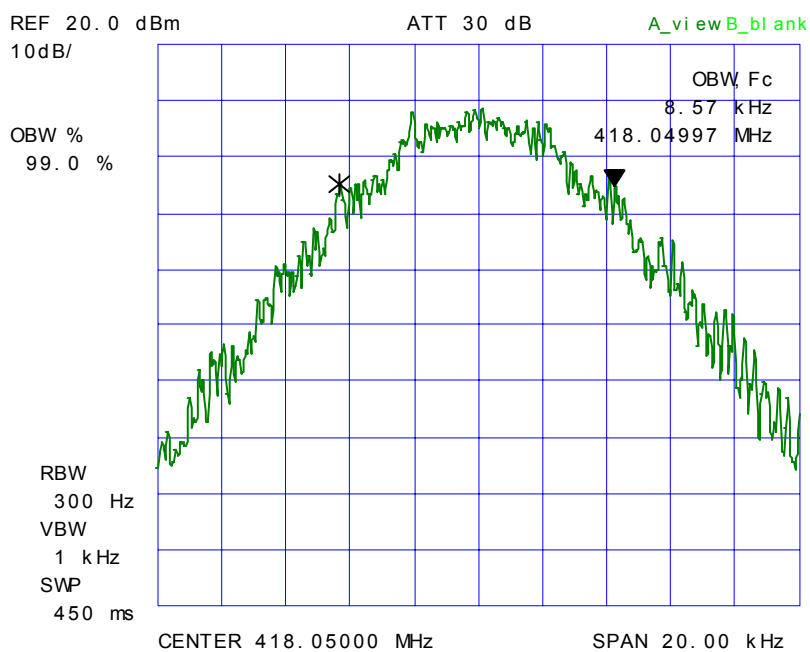

PLOT # 56 99% Occupied Bandwidth – RF Output Signal
Frequency: 418.05 MHz, 25 kHz Channel Spacing
Modulation: Digital

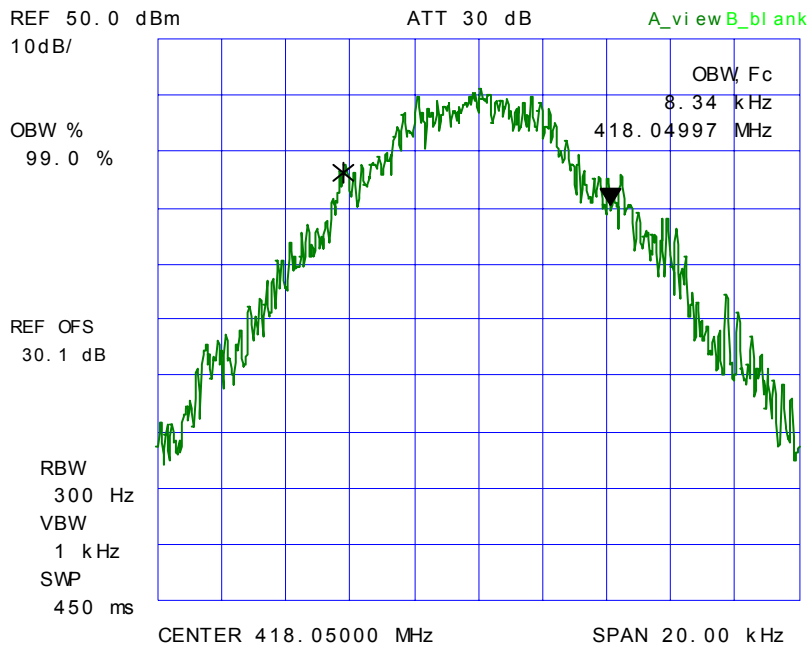

PLOT # 57 99% Occupied Bandwidth – RF Input Signal
Frequency: 430 MHz, 12.5 kHz Channel Spacing
Modulation: FM modulation with 2.5 kHz Sine wave signal

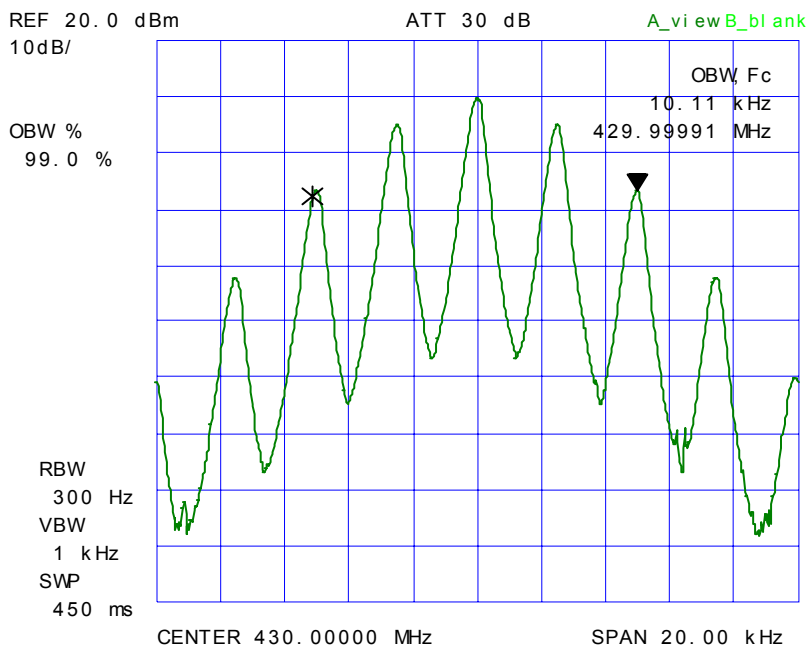

PLOT # 58 99% Occupied Bandwidth – RF Output Signal
Frequency: 430 MHz, 12.5 kHz Channel Spacing
Modulation: FM modulation with 2.5 kHz Sine wave signal

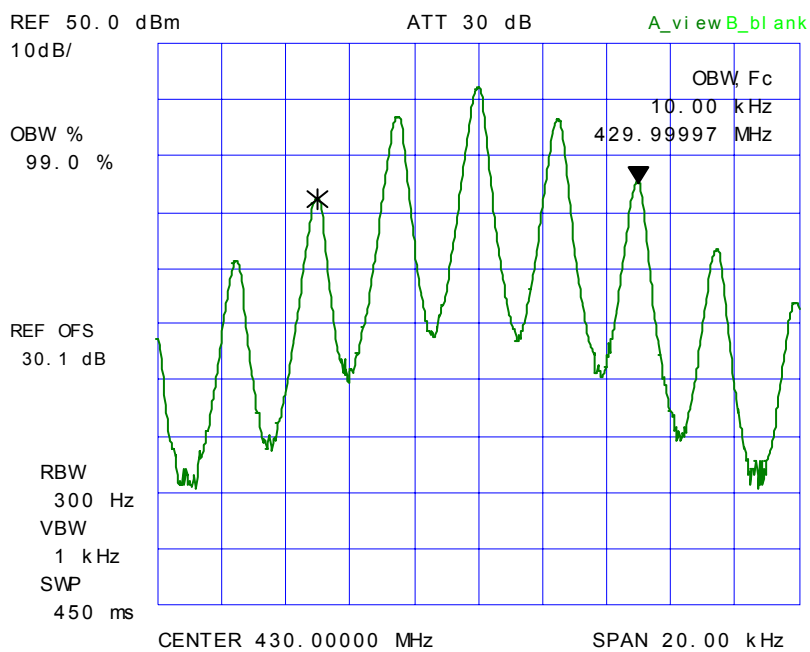

PLOT # 59 99% Occupied Bandwidth – RF Input Signal
Frequency: 430 MHz, 25 kHz Channel Spacing
Modulation: FM modulation with 5 kHz Sine wave signal

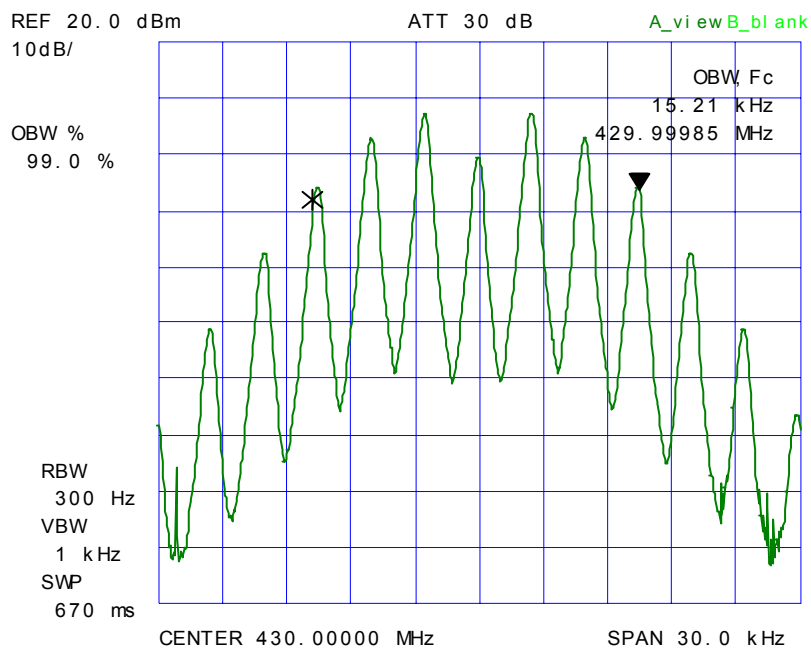

PLOT # 60 99% Occupied Bandwidth – RF Output Signal
Frequency: 430 MHz, 25 kHz Channel Spacing
Modulation: FM modulation with 5 kHz Sine wave signal

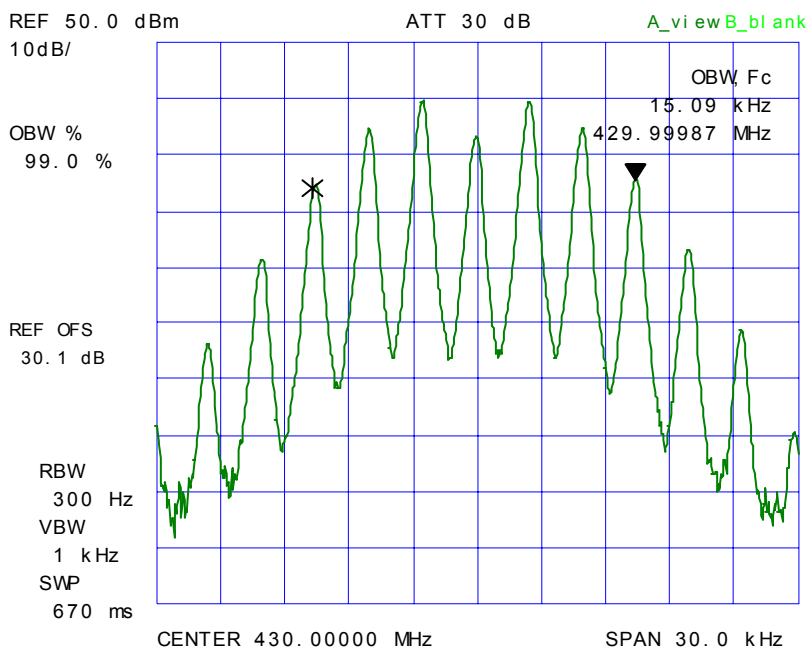

PLOT # 61 99% Occupied Bandwidth – RF Input Signal
Frequency: 430 MHz, 12.5 kHz Channel Spacing
Modulation: Digital

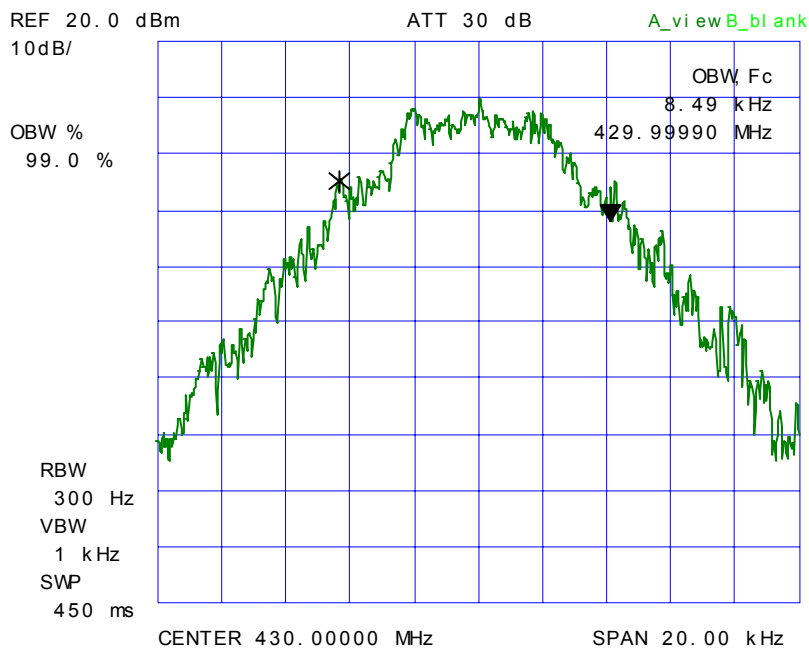

PLOT # 62 99% Occupied Bandwidth – RF Output Signal
Frequency: 430 MHz, 12.5 kHz Channel Spacing
Modulation: Digital

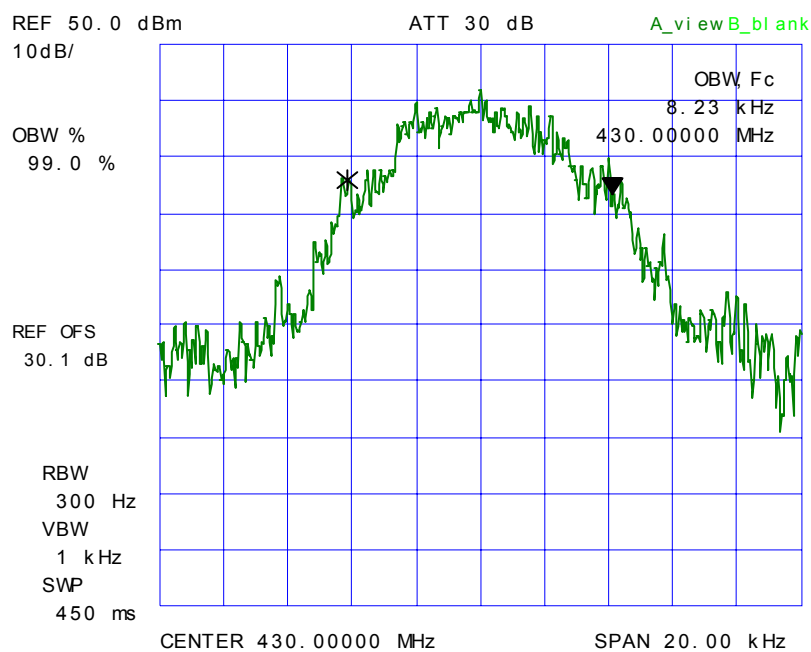

PLOT # 63 99% Occupied Bandwidth – RF Input Signal
Frequency: 430 MHz, 25 kHz Channel Spacing
Modulation: Digital

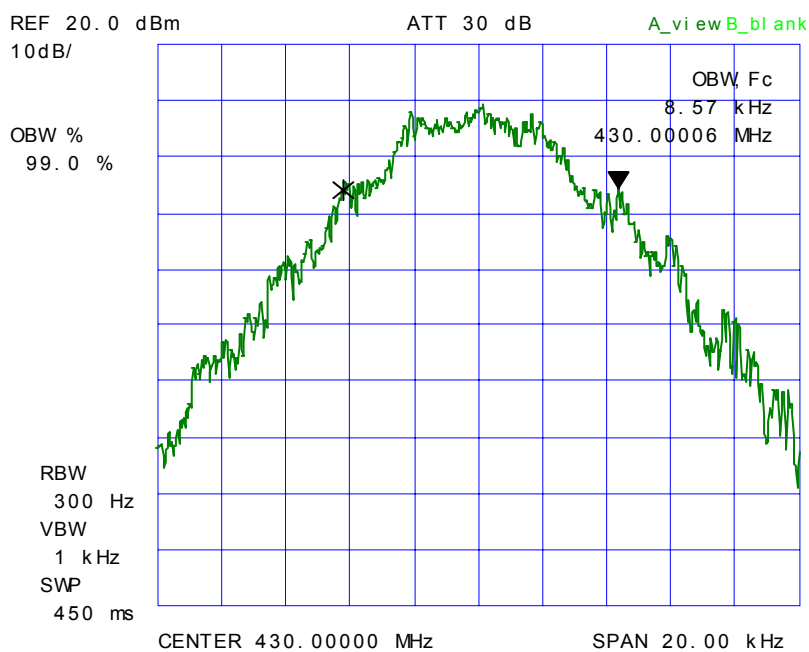

PLOT # 64 99% Occupied Bandwidth – RF Output Signal
Frequency: 430 MHz, 25 kHz Channel Spacing
Modulation: Digital

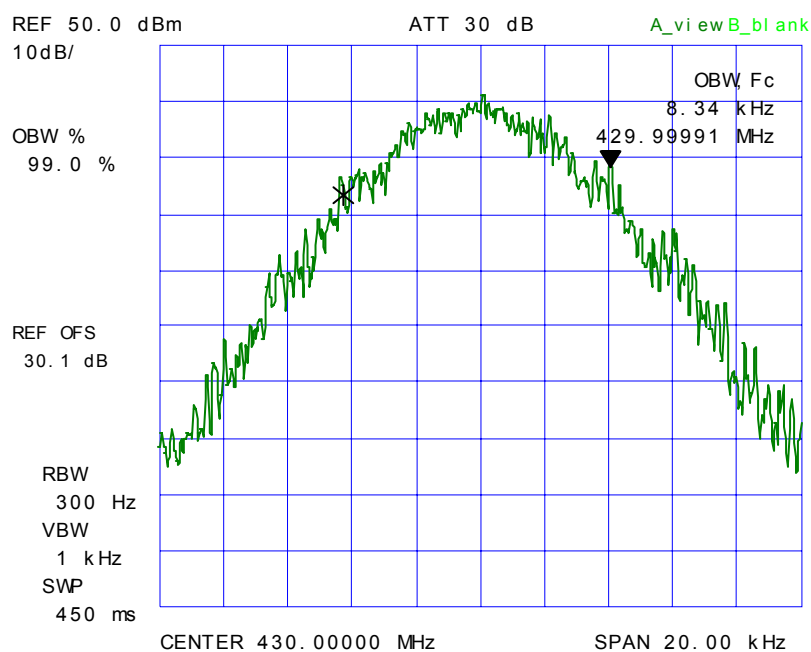

PLOT # 65 99% Occupied Bandwidth – RF Input Signal
Frequency: 450 MHz, 12.5 kHz Channel Spacing
Modulation: FM modulation with 2.5 kHz Sine wave signal

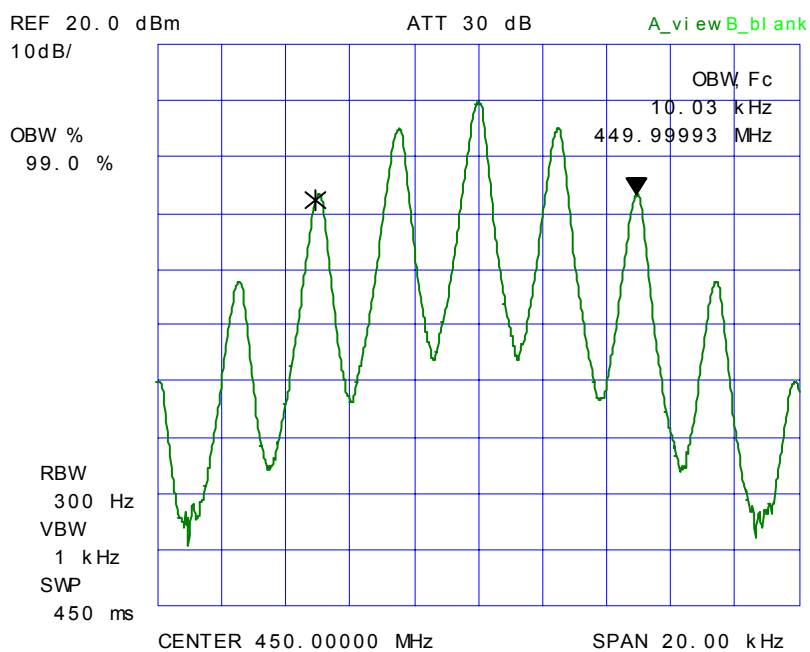

PLOT # 66 99% Occupied Bandwidth – RF Output Signal
Frequency: 450 MHz, 12.5 kHz Channel Spacing
Modulation: FM modulation with 2.5 kHz Sine wave signal

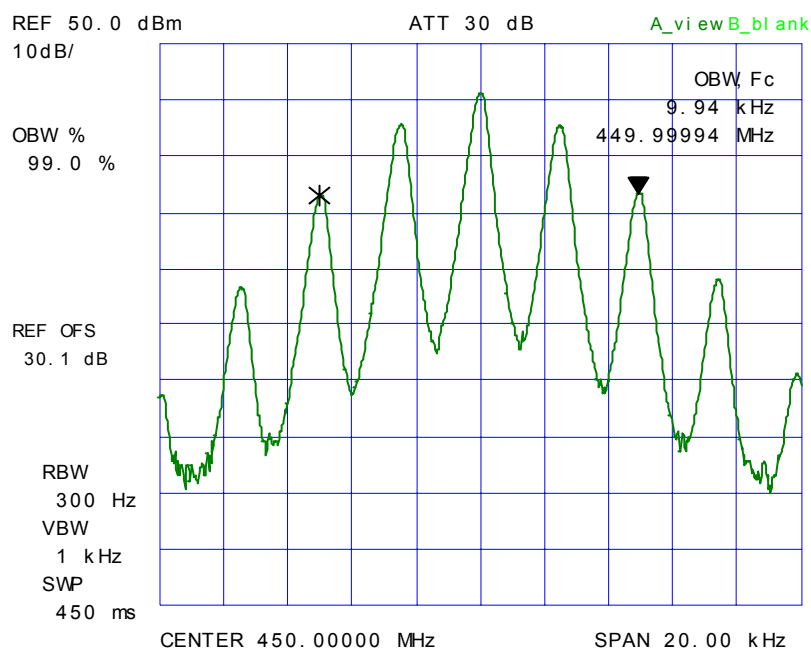

PLOT # 67 99% Occupied Bandwidth – RF Input Signal
Frequency: 450 MHz, 25 kHz Channel Spacing
Modulation: FM modulation with 5 kHz Sine wave signal

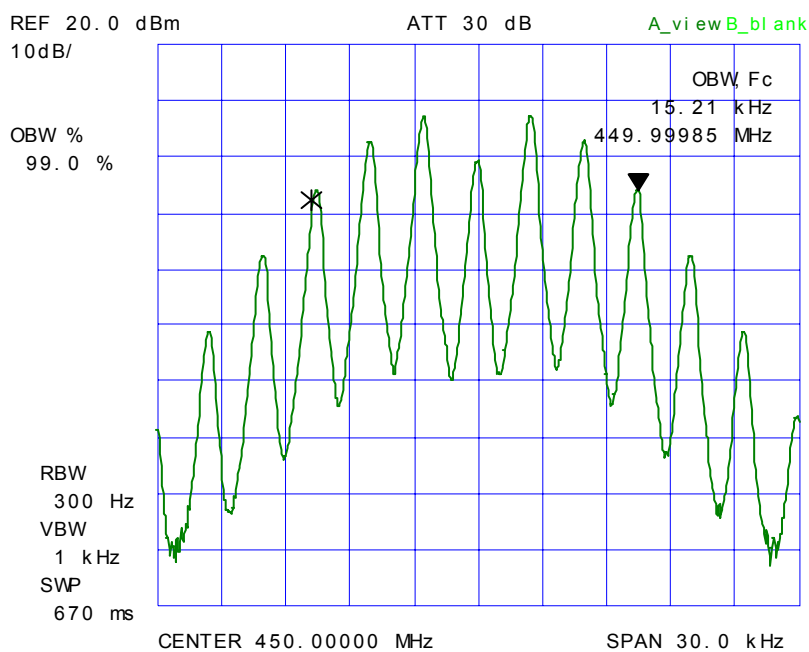

PLOT # 68 99% Occupied Bandwidth – RF Output Signal
Frequency: 450 MHz, 25 kHz Channel Spacing
Modulation: FM modulation with 5 kHz Sine wave signal

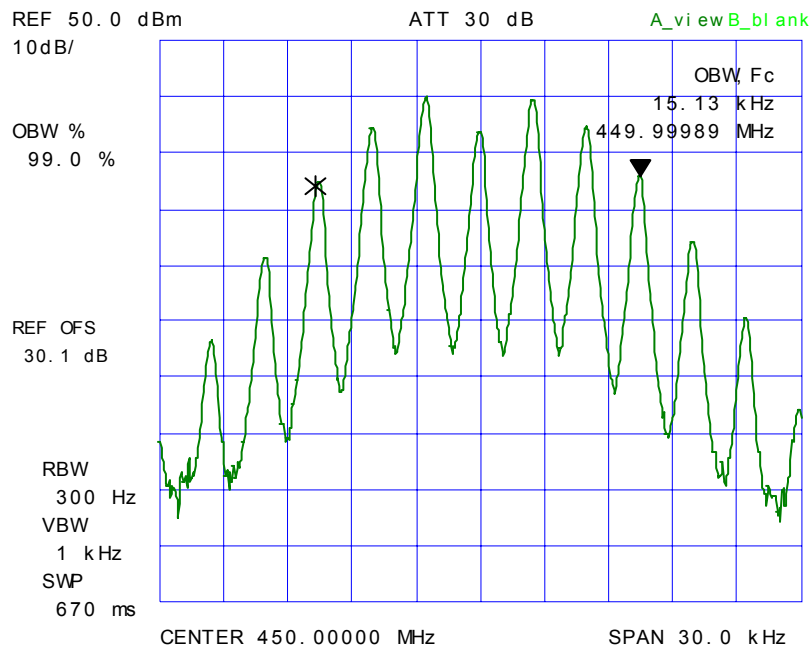

PLOT # 69 99% Occupied Bandwidth – RF Input Signal
Frequency: 450 MHz, 12.5 kHz Channel Spacing
Modulation: Digital

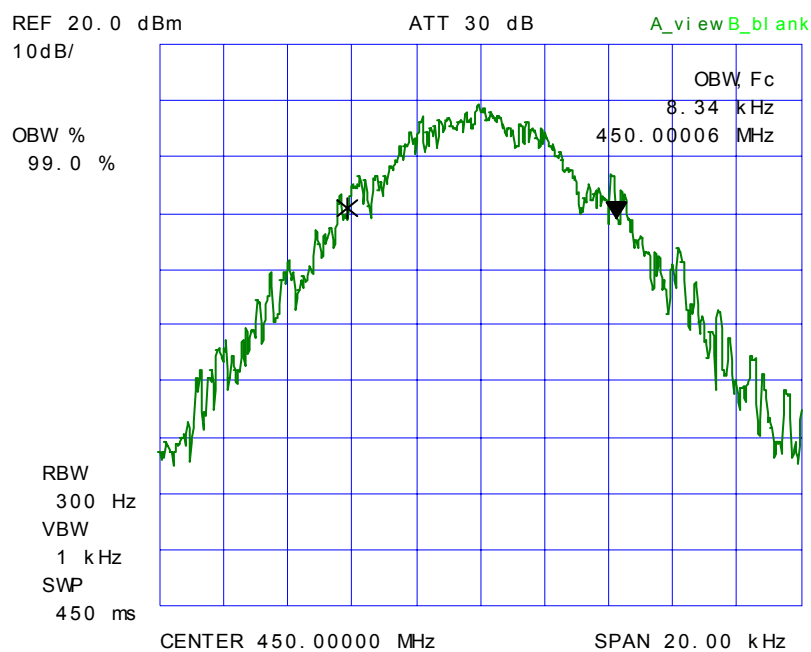

PLOT # 70 99% Occupied Bandwidth – RF Output Signal
Frequency: 450 MHz, 12.5 kHz Channel Spacing
Modulation: Digital

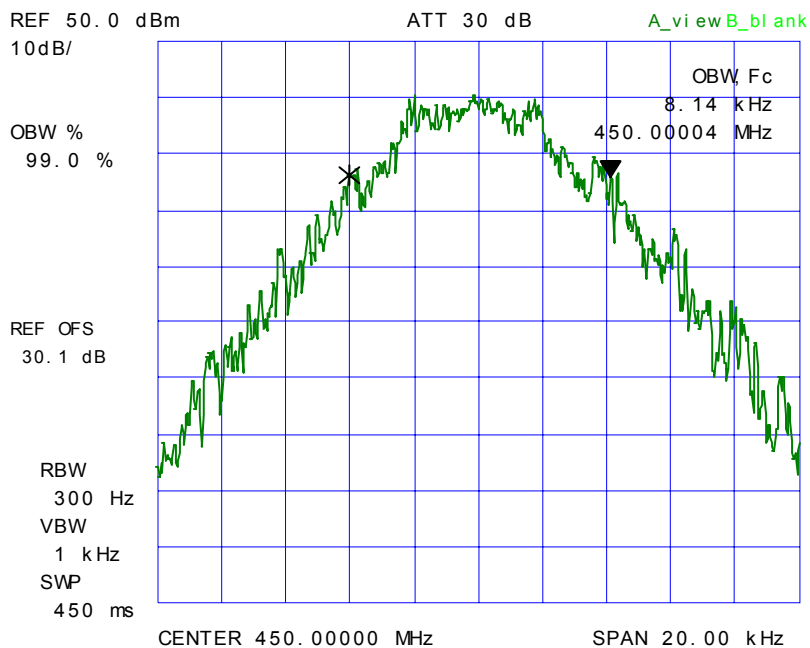

PLOT # 71 99% Occupied Bandwidth – RF Input Signal
Frequency: 450 MHz, 25 kHz Channel Spacing
Modulation: Digital

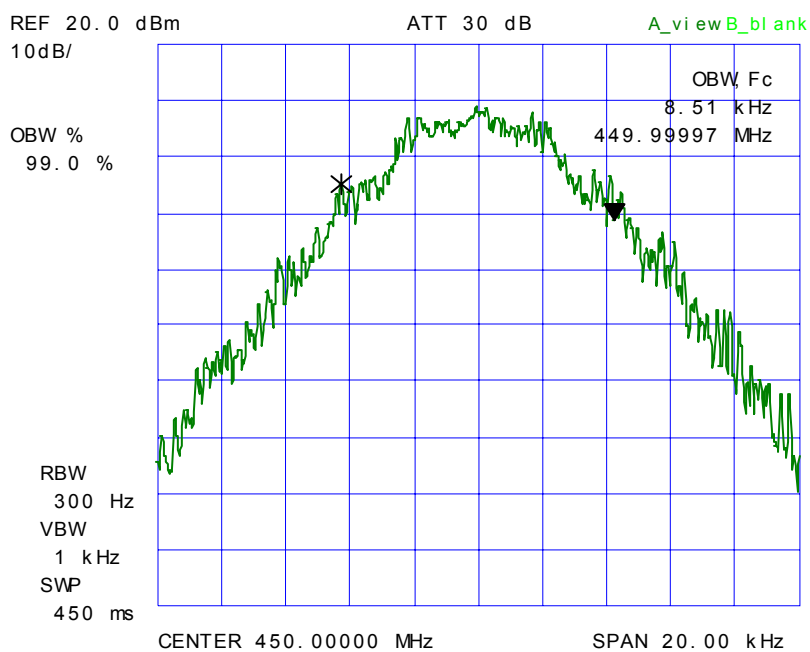

PLOT # 72 99% Occupied Bandwidth – RF Output Signal
Frequency: 450 MHz, 25 kHz Channel Spacing
Modulation: Digital

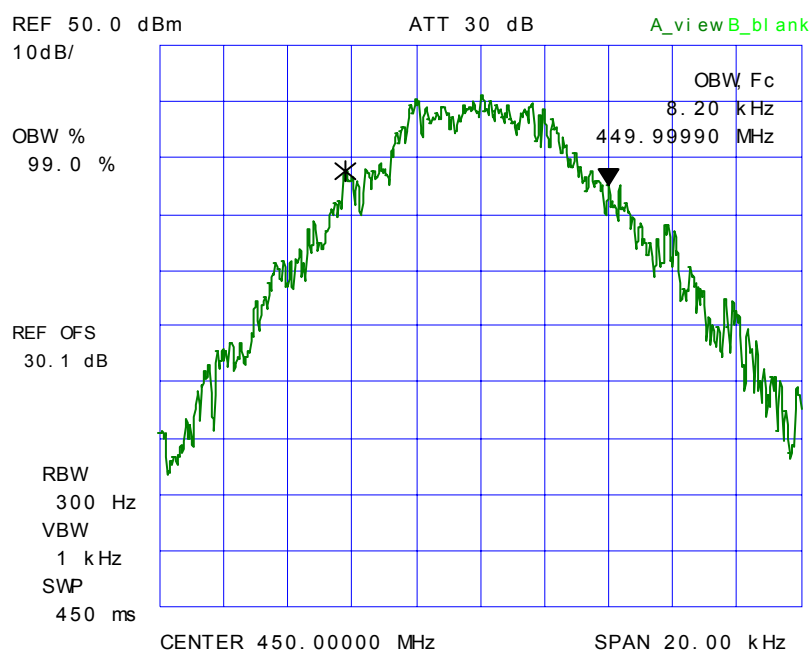

PLOT # 73 99% Occupied Bandwidth – RF Input Signal
Frequency: 460 MHz, 12.5 kHz Channel Spacing
Modulation: FM modulation with 2.5 kHz Sine wave signal

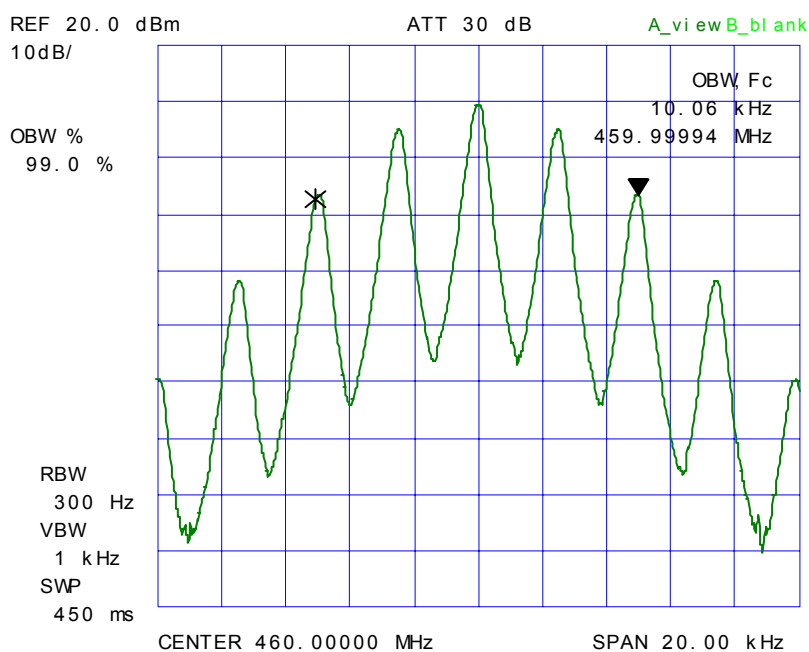

PLOT # 74 99% Occupied Bandwidth – RF Output Signal
Frequency: 460 MHz, 12.5 kHz Channel Spacing
Modulation: FM modulation with 2.5 kHz Sine wave signal

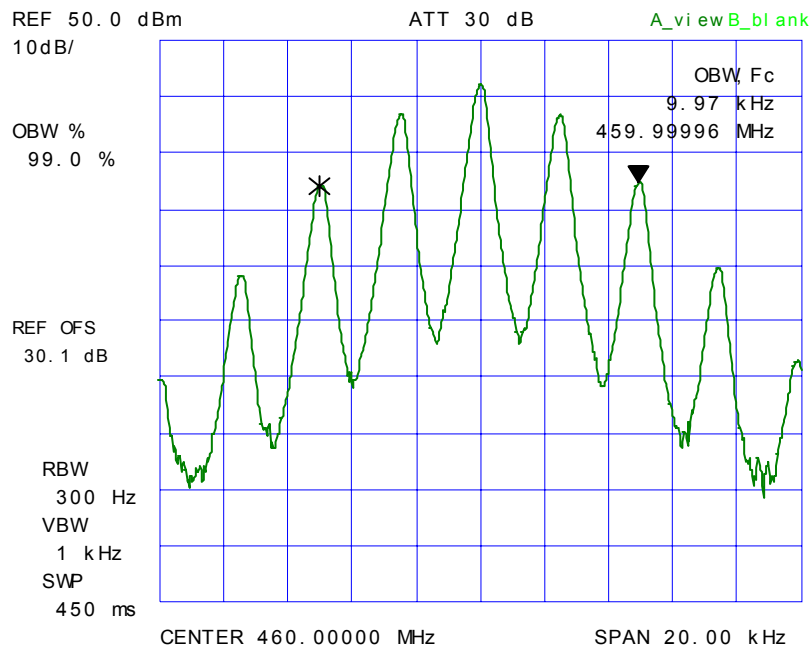

PLOT # 75 99% Occupied Bandwidth – RF Input Signal
Frequency: 460 MHz, 25 kHz Channel Spacing
Modulation: FM modulation with 5 kHz Sine wave signal

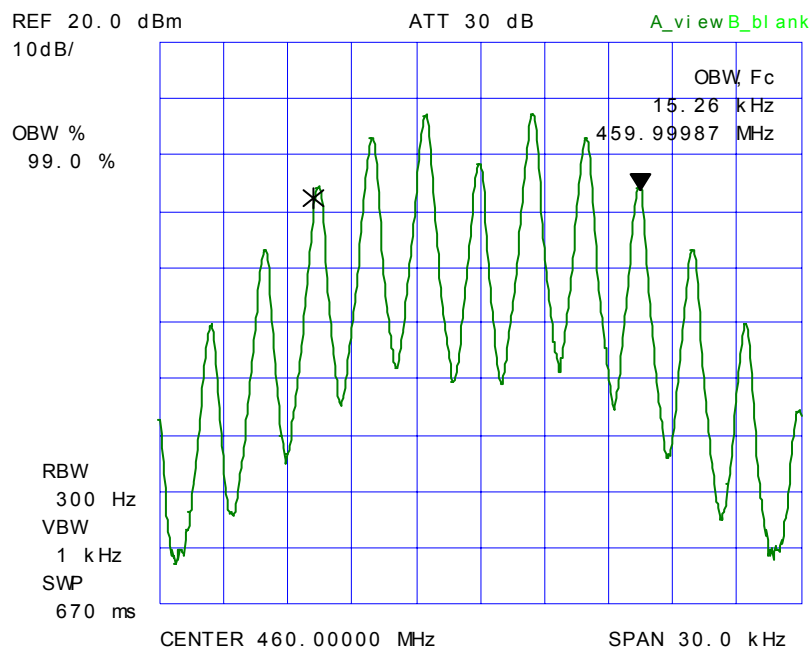

PLOT # 76 99% Occupied Bandwidth – RF Output Signal
Frequency: 460 MHz, 25 kHz Channel Spacing
Modulation: FM modulation with 5 kHz Sine wave signal

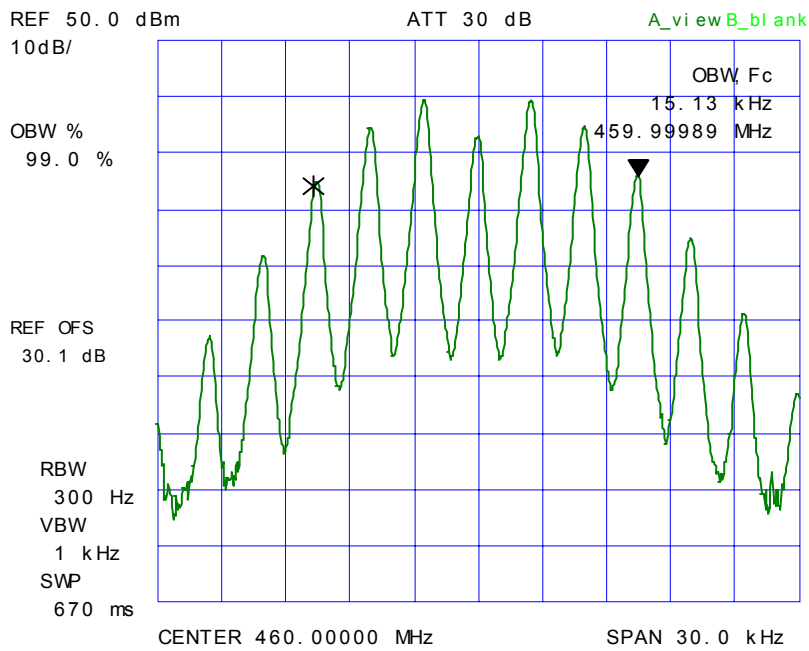

PLOT # 77 99% Occupied Bandwidth – RF Input Signal
Frequency: 460 MHz, 12.5 kHz Channel Spacing
Modulation: Digital

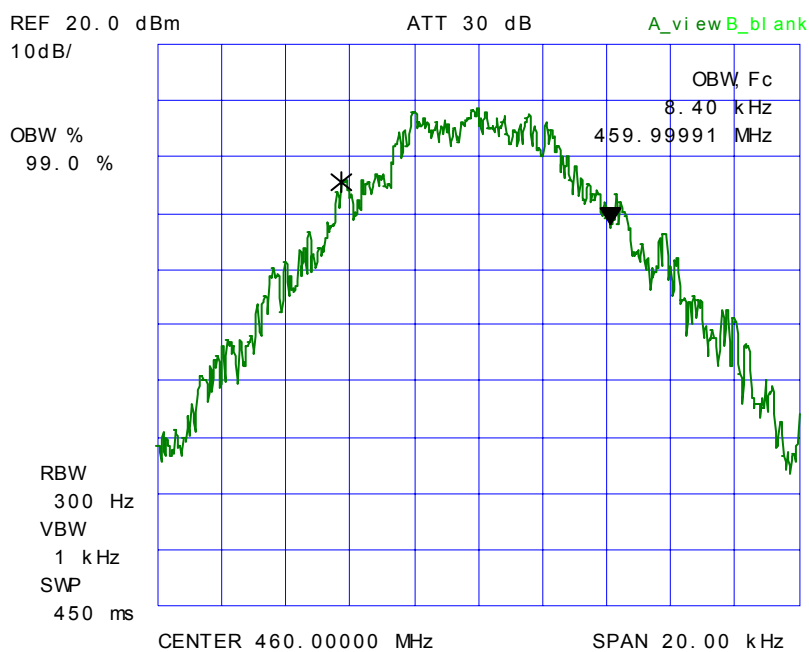

PLOT # 78 99% Occupied Bandwidth – RF Output Signal
Frequency: 460 MHz, 12.5 kHz Channel Spacing
Modulation: Digital

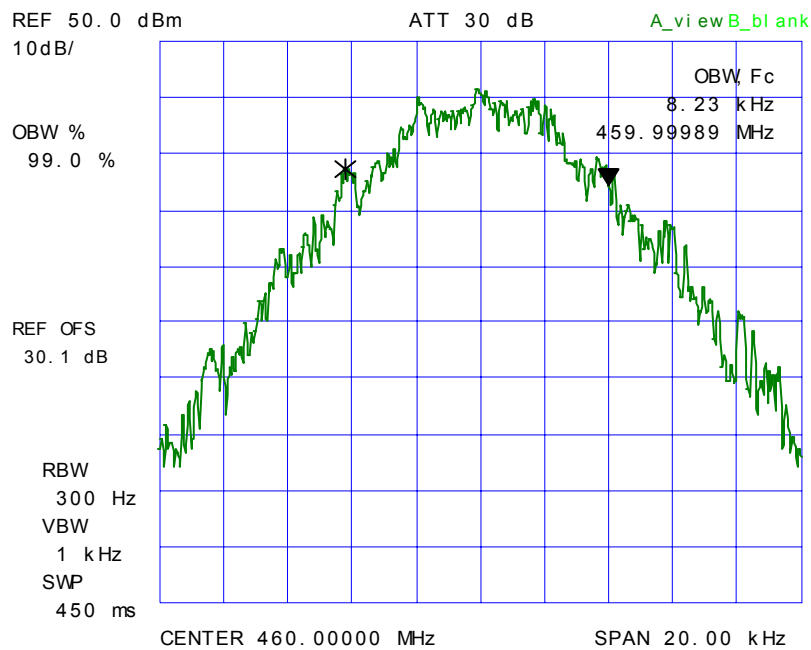

PLOT # 79 99% Occupied Bandwidth – RF Input Signal
Frequency: 460 MHz, 25 kHz Channel Spacing
Modulation: Digital

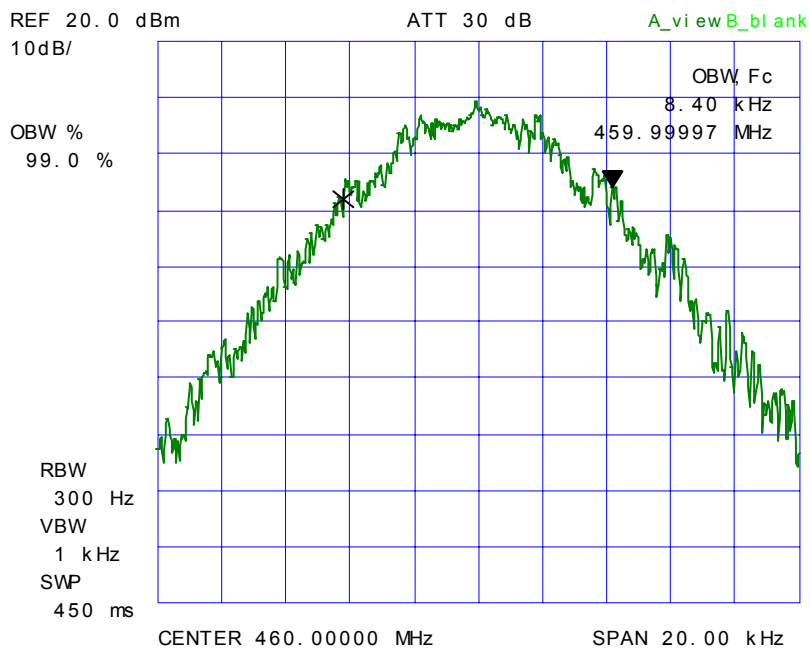

PLOT # 80 99% Occupied Bandwidth – RF Output Signal
Frequency: 460 MHz, 25 kHz Channel Spacing
Modulation: Digital

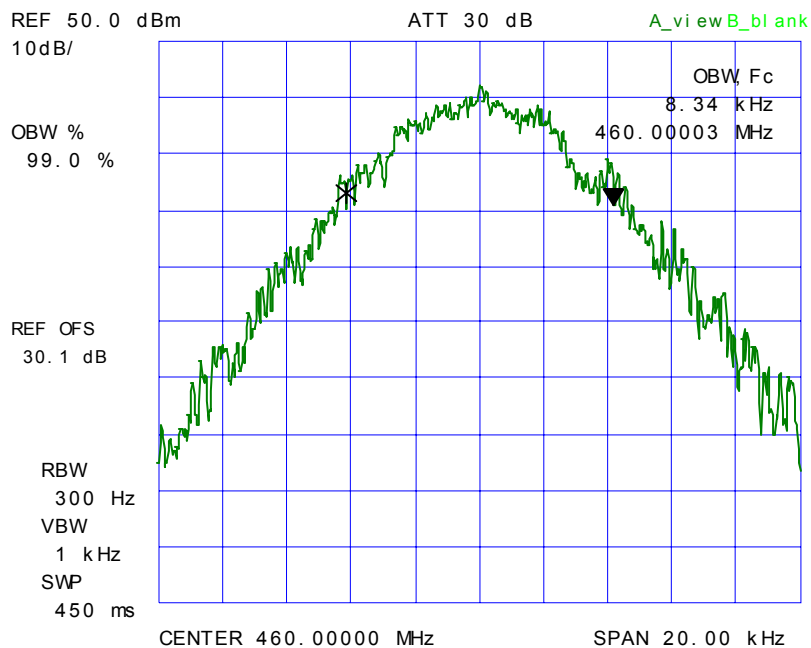

PLOT # 81 99% Occupied Bandwidth – RF Input Signal
Frequency: 470 MHz, 12.5 kHz Channel Spacing
Modulation: FM modulation with 2.5 kHz Sine wave signal

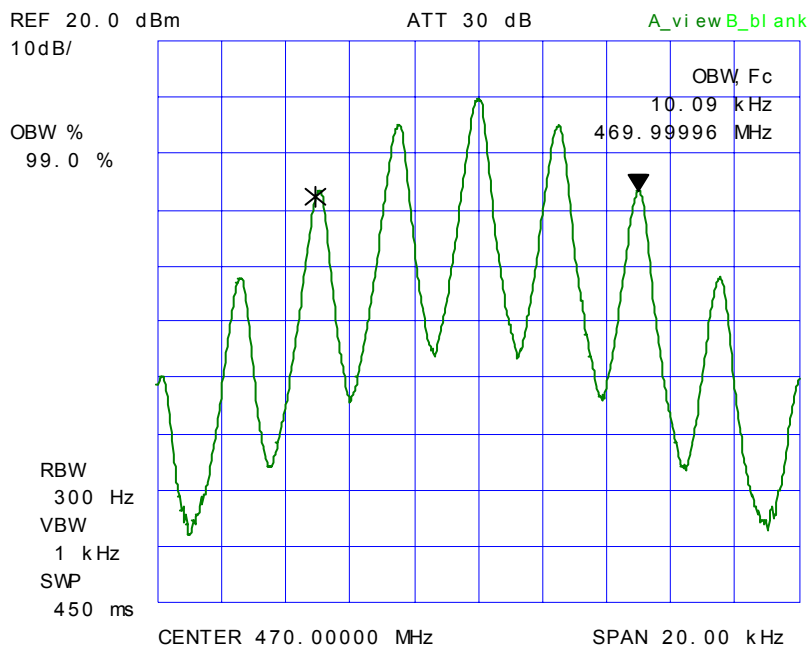

PLOT # 82 99% Occupied Bandwidth – RF Output Signal
Frequency: 470 MHz, 12.5 kHz Channel Spacing
Modulation: FM modulation with 2.5 kHz Sine wave signal

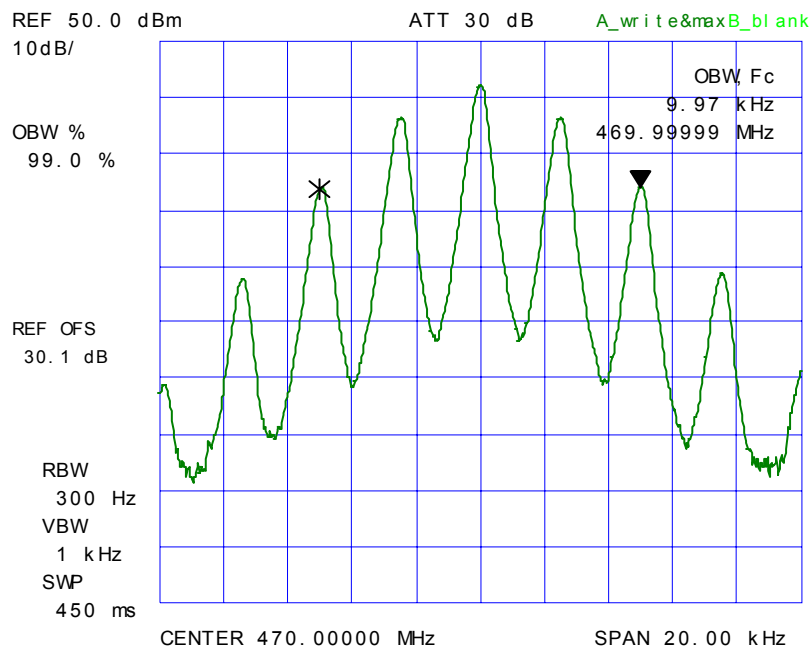

PLOT # 83 99% Occupied Bandwidth – RF Input Signal
Frequency: 470 MHz, 25 kHz Channel Spacing
Modulation: FM modulation with 5 kHz Sine wave signal

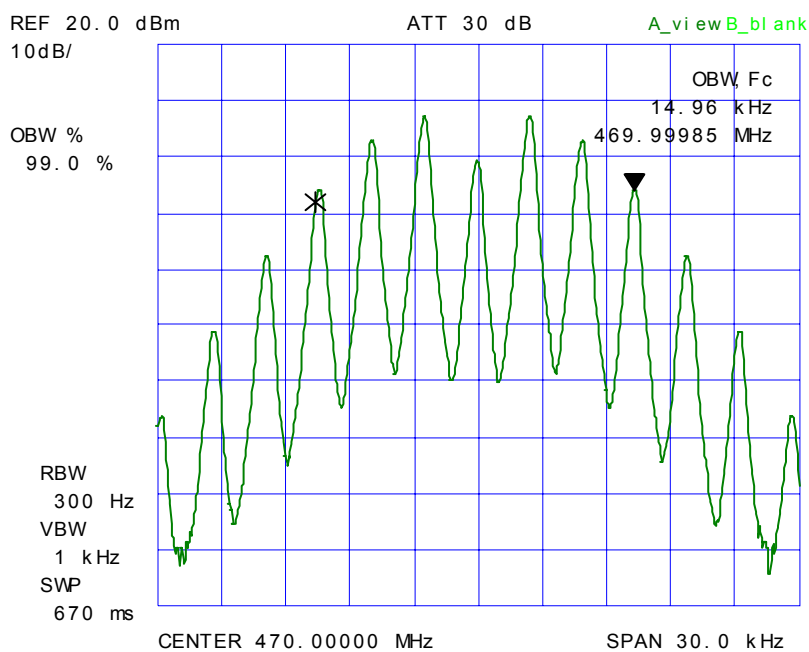

PLOT # 84 99% Occupied Bandwidth – RF Output Signal
Frequency: 470 MHz, 25 kHz Channel Spacing
Modulation: FM modulation with 5 kHz Sine wave signal

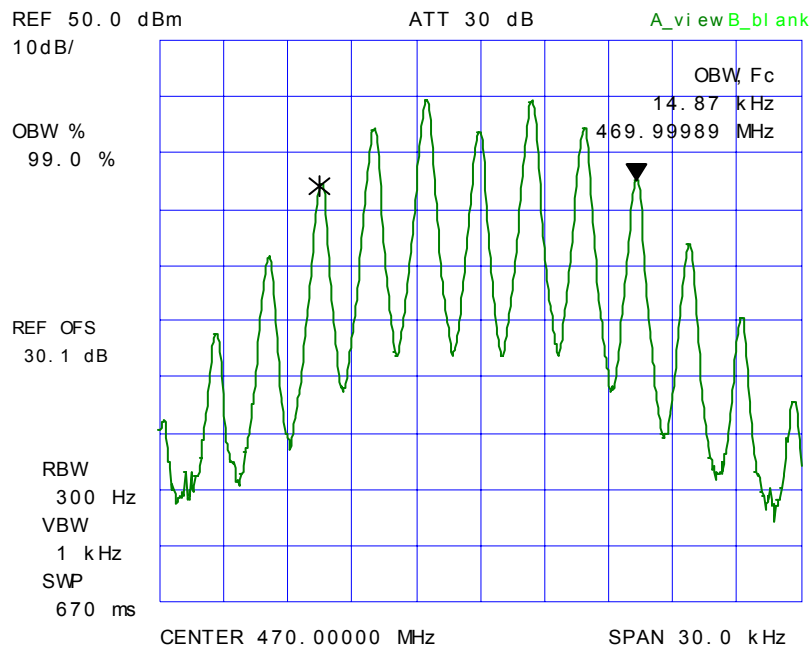

PLOT # 85 99% Occupied Bandwidth – RF Input Signal
Frequency: 470 MHz, 12.5 kHz Channel Spacing
Modulation: Digital

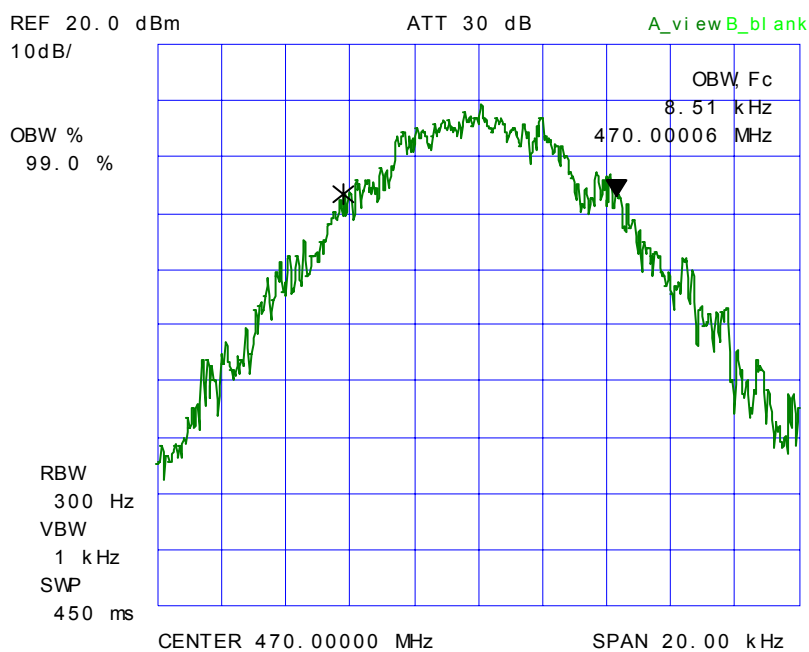

PLOT # 86 99% Occupied Bandwidth – RF Output Signal
Frequency: 470 MHz, 12.5 kHz Channel Spacing
Modulation: Digital

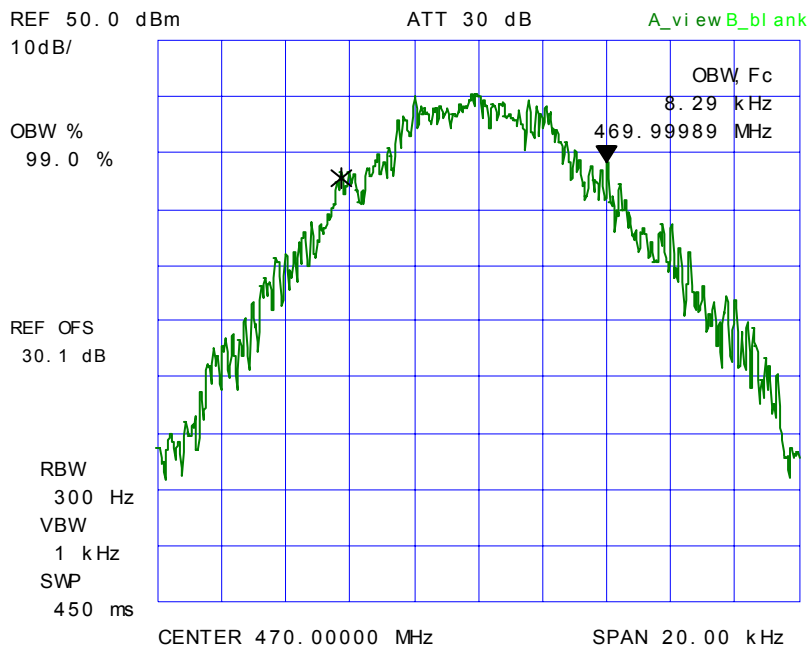

PLOT # 87 99% Occupied Bandwidth – RF Input Signal
Frequency: 470 MHz, 25 kHz Channel Spacing
Modulation: Digital

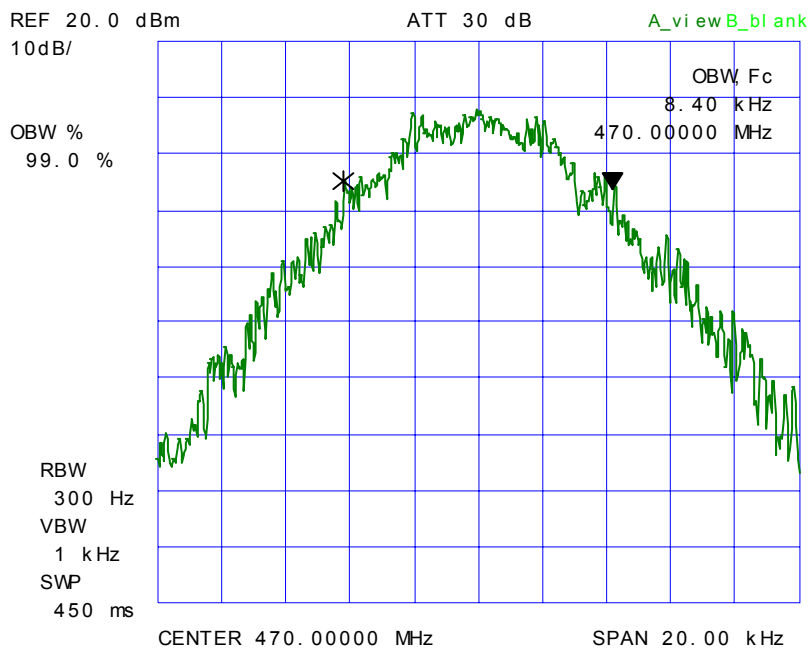

PLOT # 88 99% Occupied Bandwidth – RF Output Signal
Frequency: 470 MHz, 25 kHz Channel Spacing
Modulation: Digital

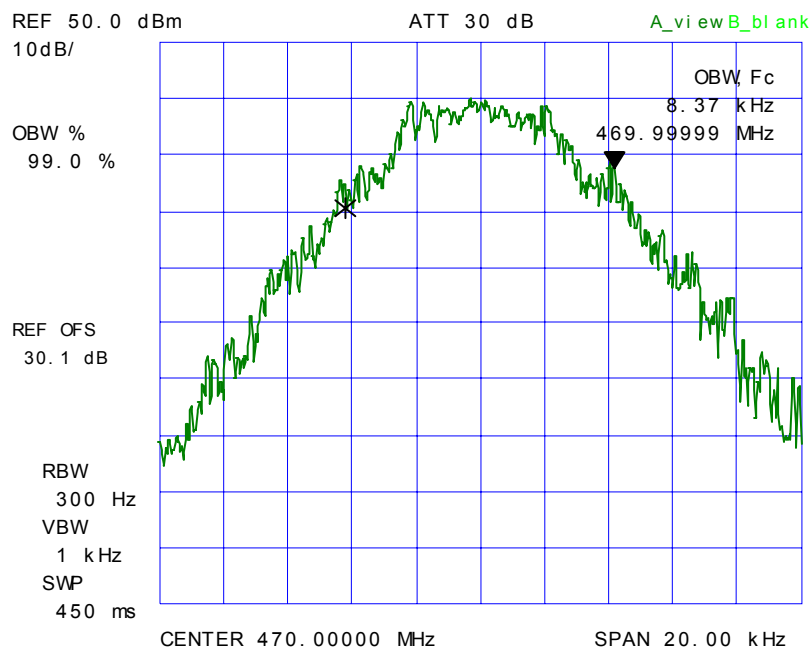

PLOT # 89 99% Occupied Bandwidth – RF Input Signal
Frequency: 470 MHz, 12.5 kHz Channel Spacing
Modulation: FM modulation with 2.5 kHz Sine wave signal

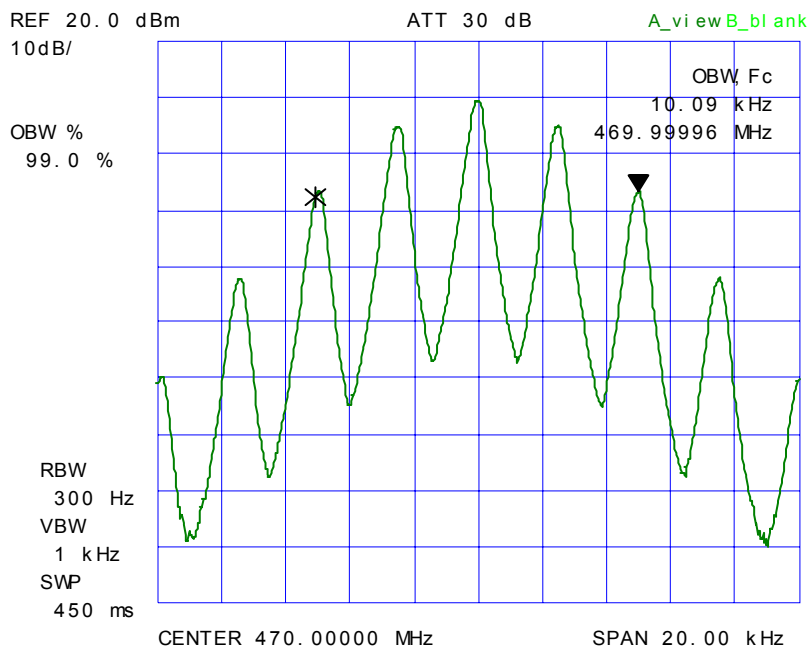

PLOT # 90 99% Occupied Bandwidth – RF Output Signal
Frequency: 470 MHz, 12.5 kHz Channel Spacing
Modulation: FM modulation with 2.5 kHz Sine wave signal

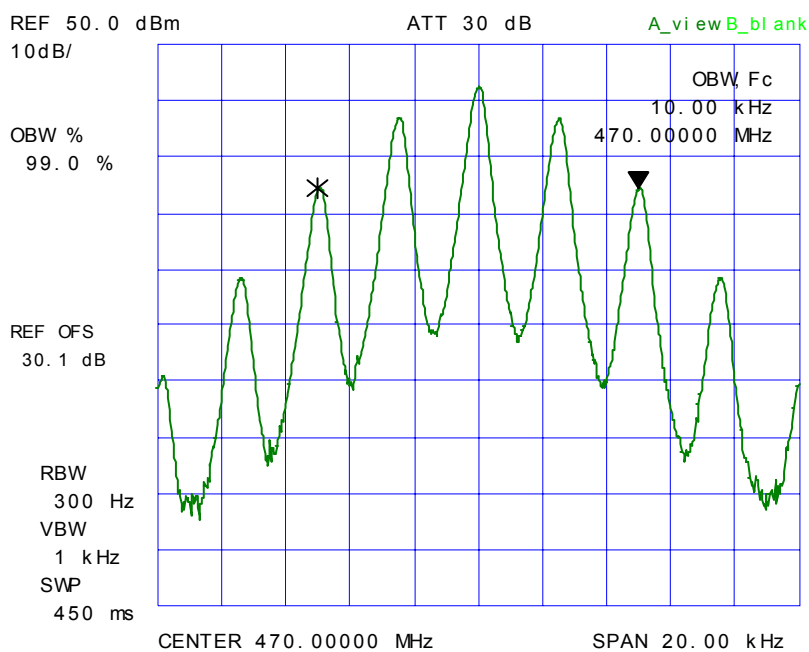

PLOT # 91 99% Occupied Bandwidth – RF Input Signal
Frequency: 470 MHz, 25 kHz Channel Spacing
Modulation: FM modulation with 5 kHz Sine wave signal

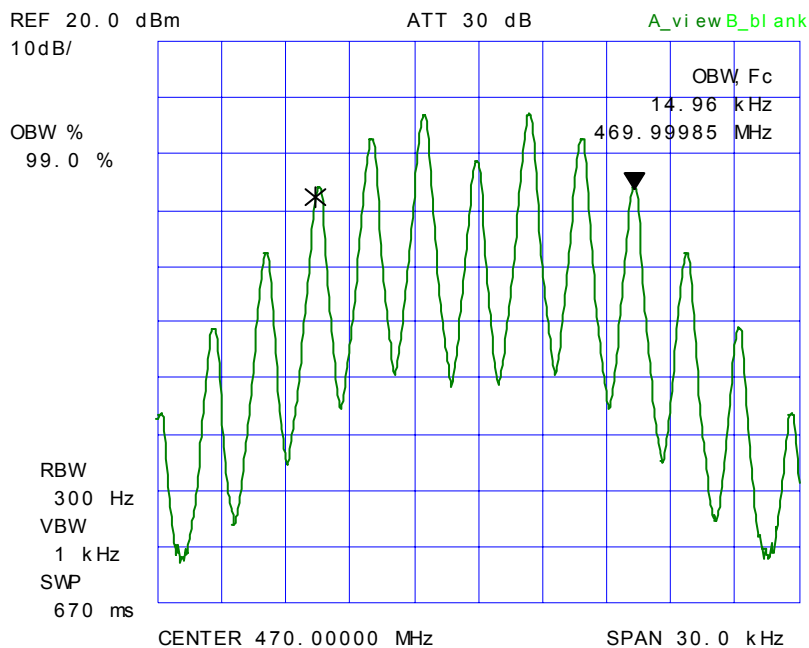

PLOT # 92 99% Occupied Bandwidth – RF Output Signal
Frequency: 470 MHz, 25 kHz Channel Spacing
Modulation: FM modulation with 5 kHz Sine wave signal

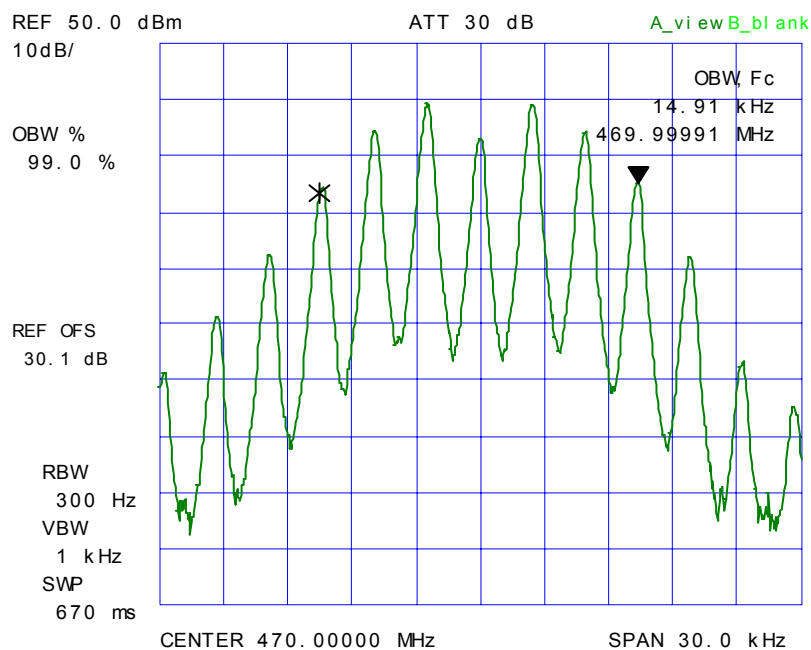

PLOT # 93 99% Occupied Bandwidth – RF Input Signal
Frequency: 470 MHz, 12.5 kHz Channel Spacing
Modulation: Digital

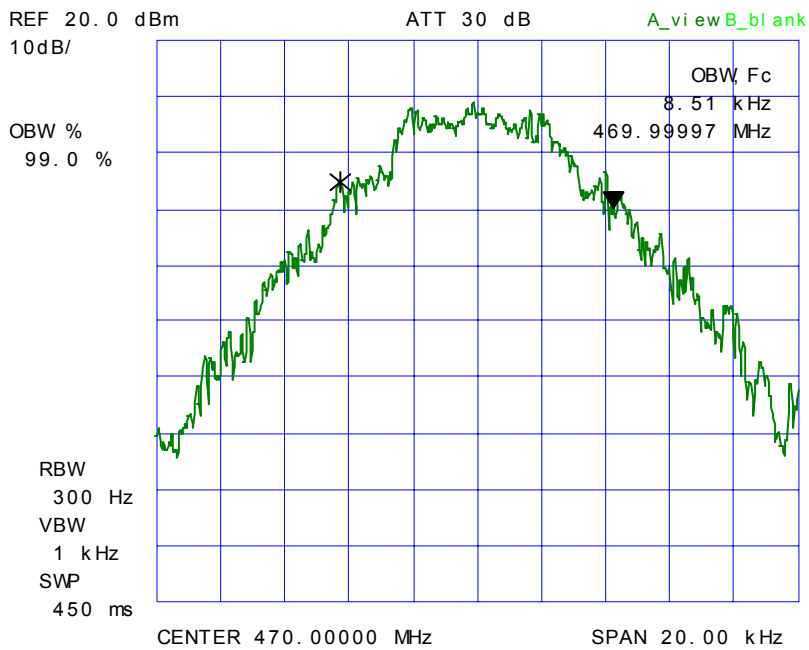

PLOT # 94 99% Occupied Bandwidth – RF Output Signal
Frequency: 470 MHz, 12.5 kHz Channel Spacing
Modulation: Digital

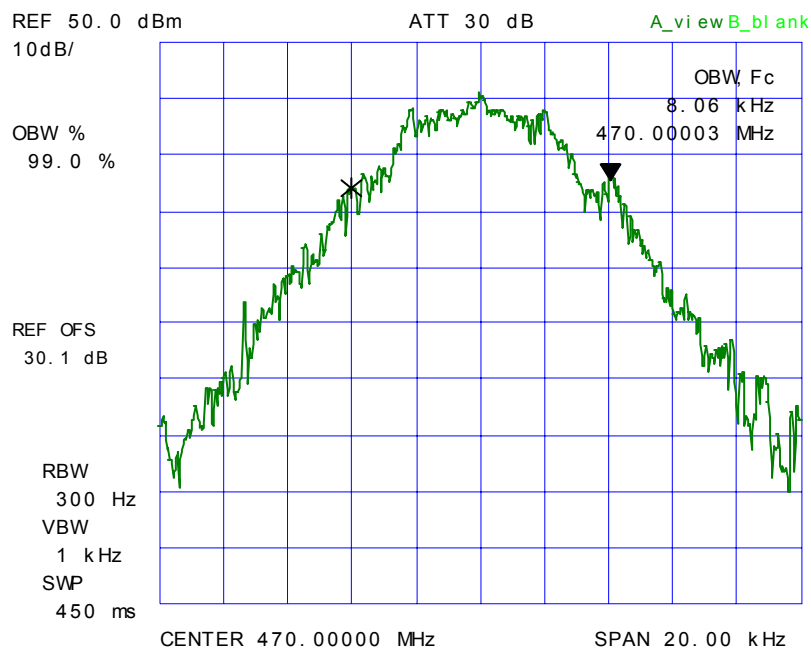

PLOT # 95 99% Occupied Bandwidth – RF Input Signal
Frequency: 470 MHz, 25 kHz Channel Spacing
Modulation: Digital

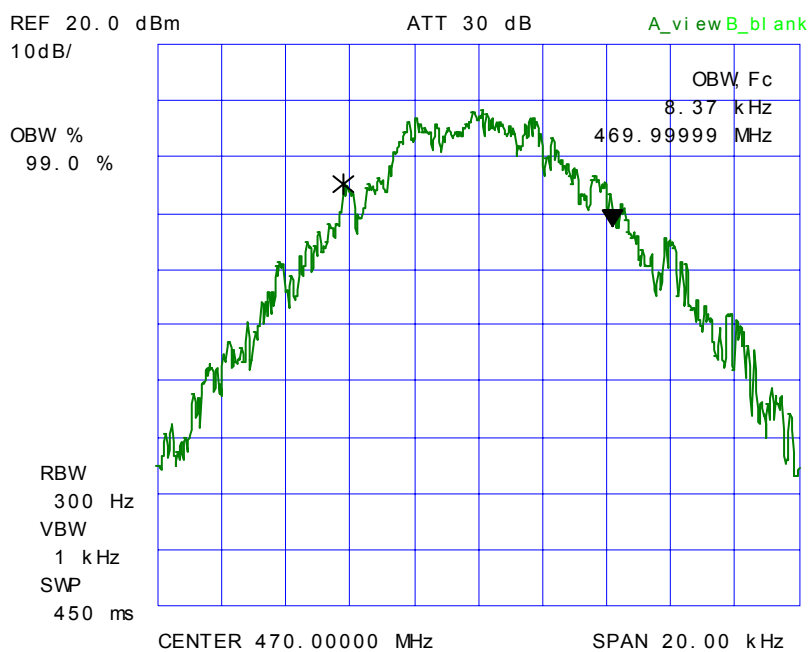

PLOT # 96 99% Occupied Bandwidth – RF Output Signal
Frequency: 470 MHz, 25 kHz Channel Spacing
Modulation: Digital

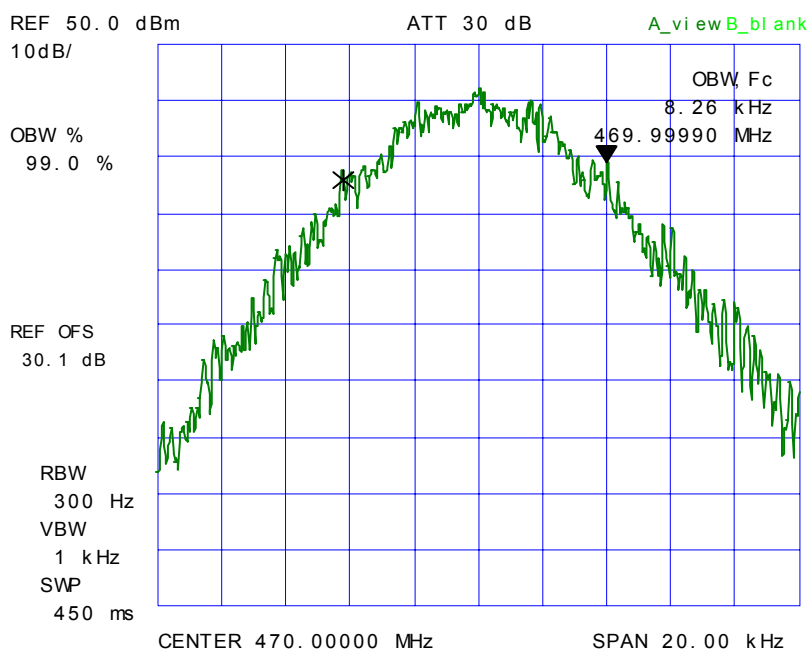

PLOT # 97 99% Occupied Bandwidth – RF Input Signal
Frequency: 491 MHz, 12.5 kHz Channel Spacing
Modulation: FM modulation with 2.5 kHz Sine wave signal

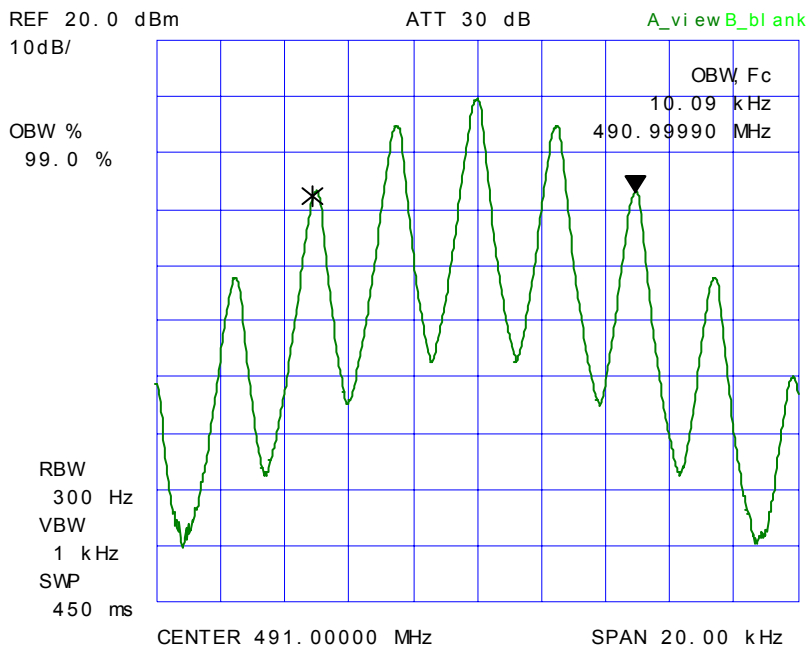

PLOT # 98 99% Occupied Bandwidth – RF Output Signal
Frequency: 491 MHz, 12.5 kHz Channel Spacing
Modulation: FM modulation with 2.5 kHz Sine wave signal

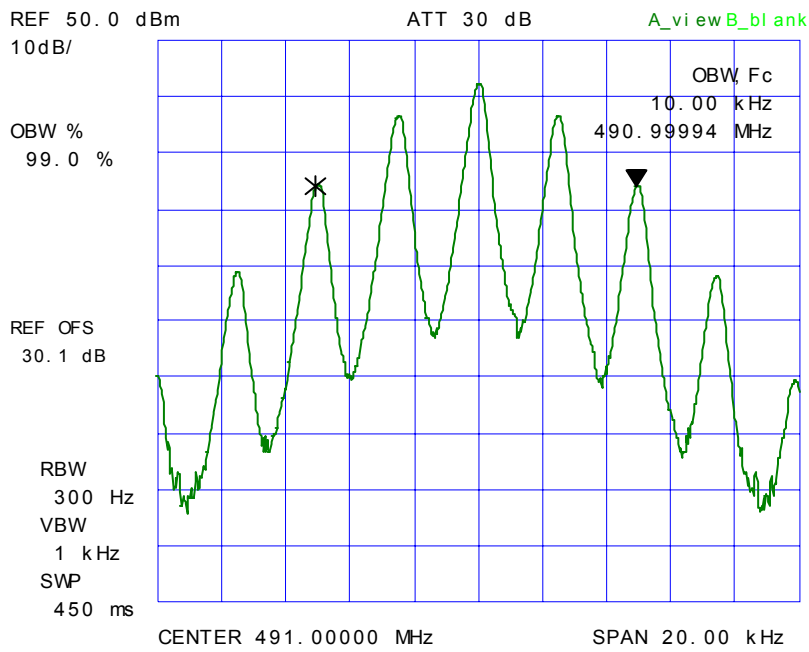

PLOT # 99 99% Occupied Bandwidth – RF Input Signal
Frequency: 491 MHz, 25 kHz Channel Spacing
Modulation: FM modulation with 5 kHz Sine wave signal

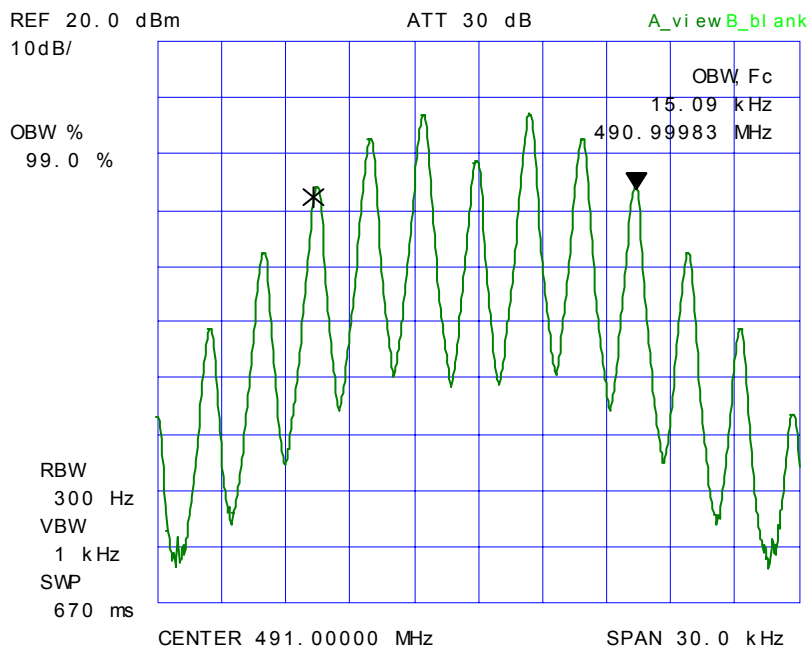

PLOT # 100 99% Occupied Bandwidth – RF Output Signal
Frequency: 491 MHz, 25 kHz Channel Spacing
Modulation: FM modulation with 5 kHz Sine wave signal

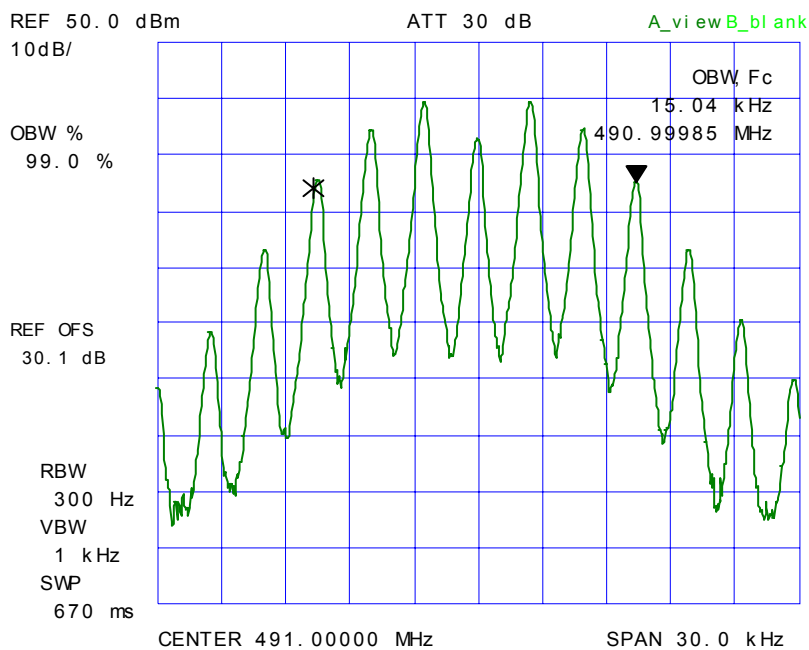

PLOT # 101 99% Occupied Bandwidth – RF Input Signal
Frequency: 491 MHz, 12.5 kHz Channel Spacing
Modulation: Digital

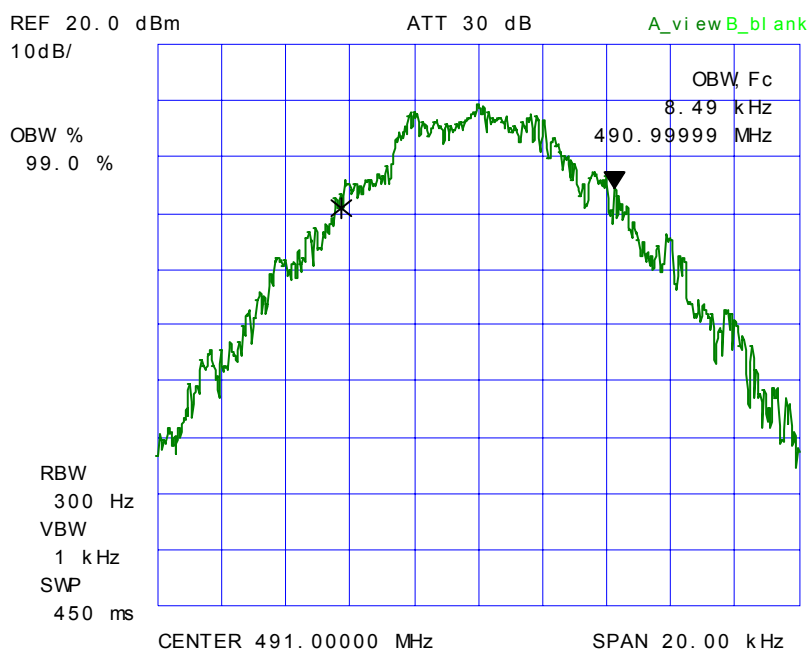

PLOT # 102 99% Occupied Bandwidth – RF Output Signal
Frequency: 491 MHz, 12.5 kHz Channel Spacing
Modulation: Digital

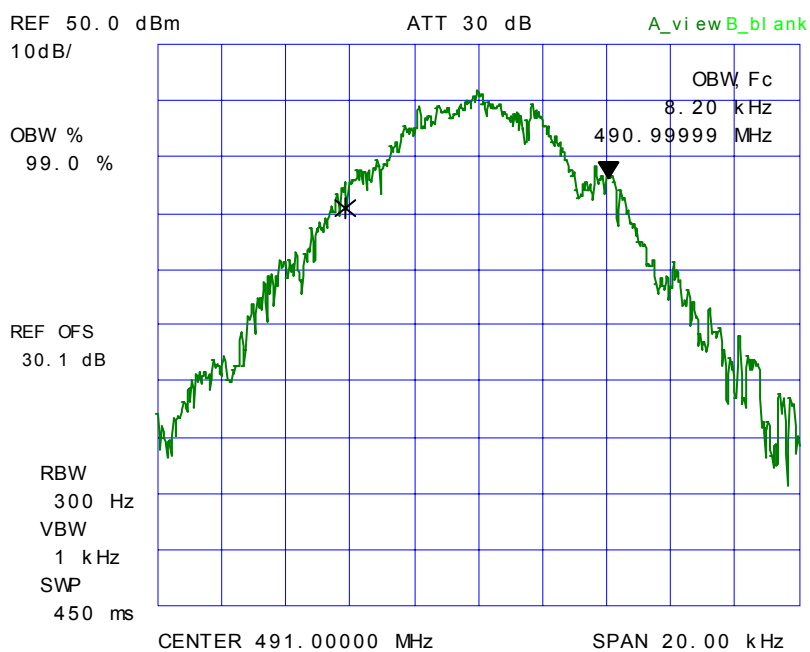

PLOT # 103 99% Occupied Bandwidth – RF Input Signal
Frequency: 491 MHz, 25 kHz Channel Spacing
Modulation: Digital

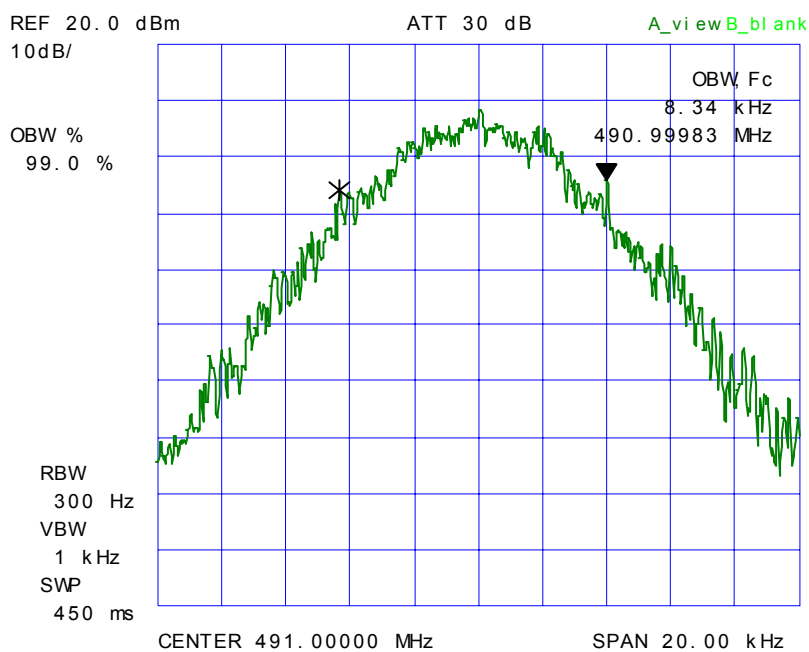

PLOT # 104 99% Occupied Bandwidth – RF Output Signal
Frequency: 491 MHz, 25 kHz Channel Spacing
Modulation: Digital

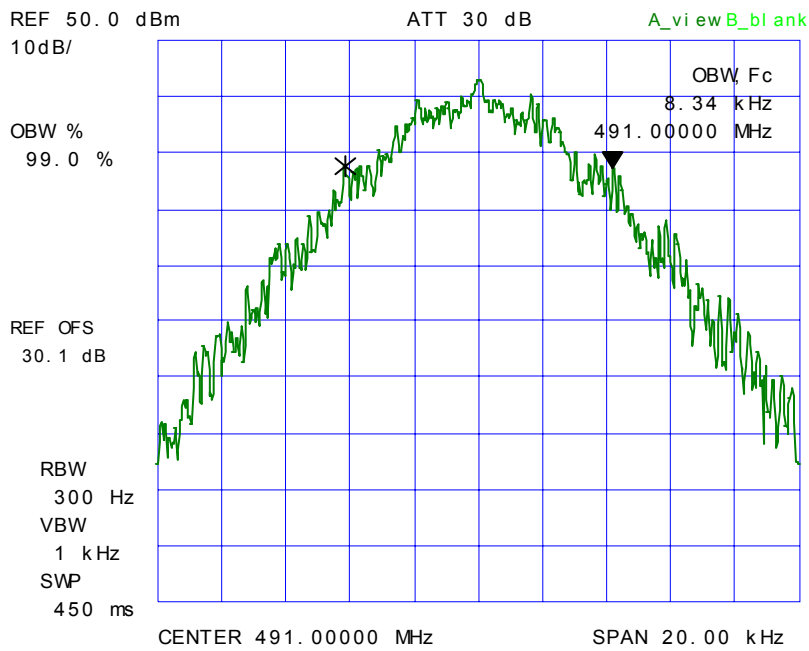

PLOT # 105 99% Occupied Bandwidth – RF Input Signal
Frequency: 512 MHz, 12.5 kHz Channel Spacing
Modulation: FM modulation with 2.5 kHz Sine wave signal

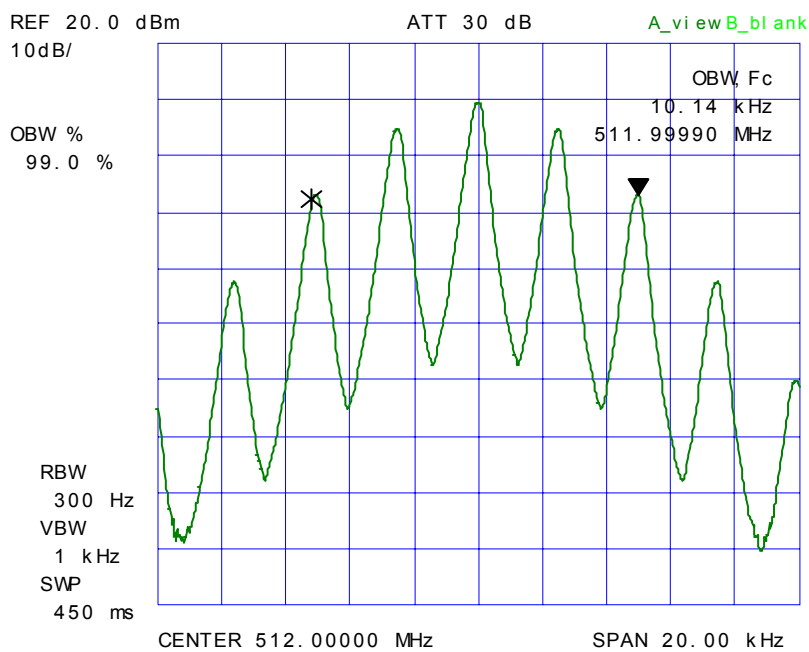

PLOT # 106 99% Occupied Bandwidth – RF Output Signal
Frequency: 512 MHz, 12.5 kHz Channel Spacing
Modulation: FM modulation with 2.5 kHz Sine wave signal

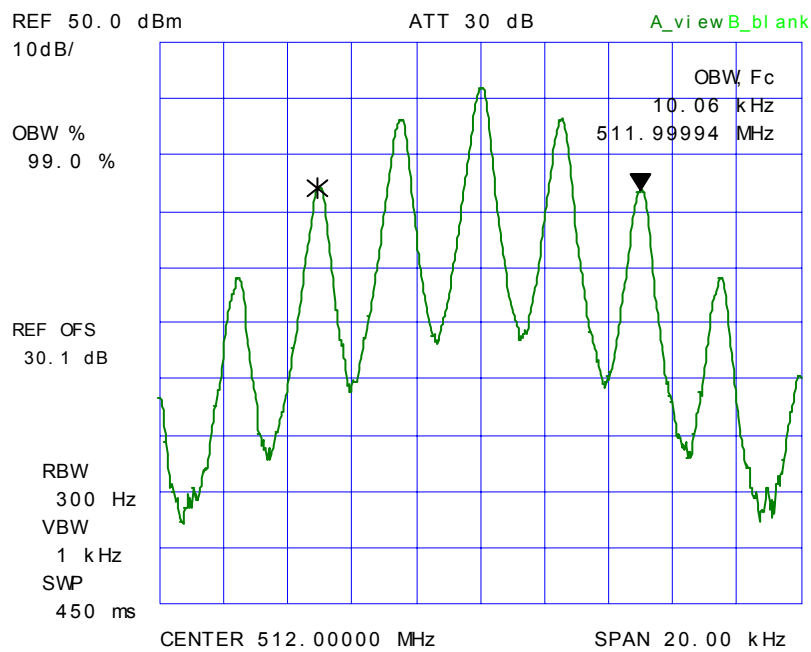

PLOT # 107 99% Occupied Bandwidth – RF Input Signal
Frequency: 512 MHz, 25 kHz Channel Spacing
Modulation: FM modulation with 5 kHz Sine wave signal

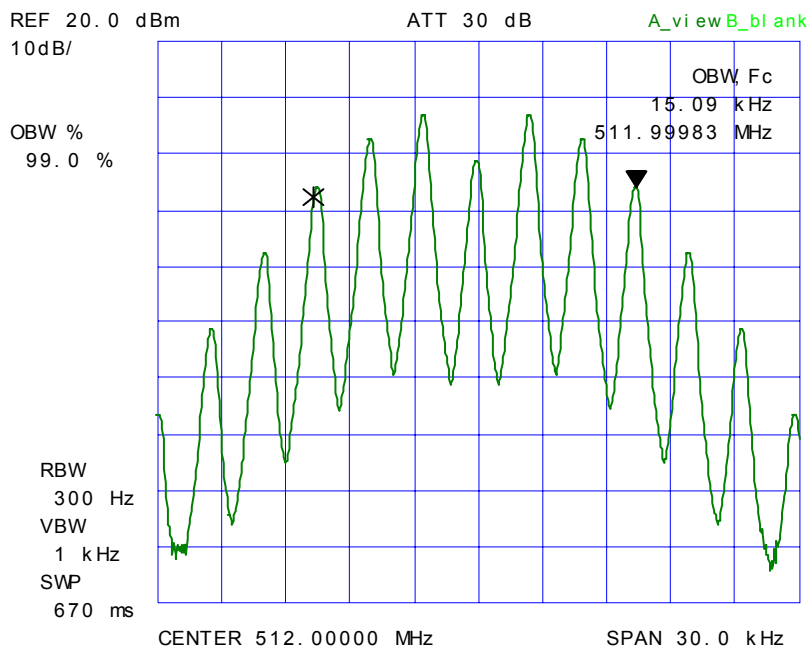

PLOT # 108 99% Occupied Bandwidth – RF Output Signal
Frequency: 512 MHz, 25 kHz Channel Spacing
Modulation: FM modulation with 5 kHz Sine wave signal

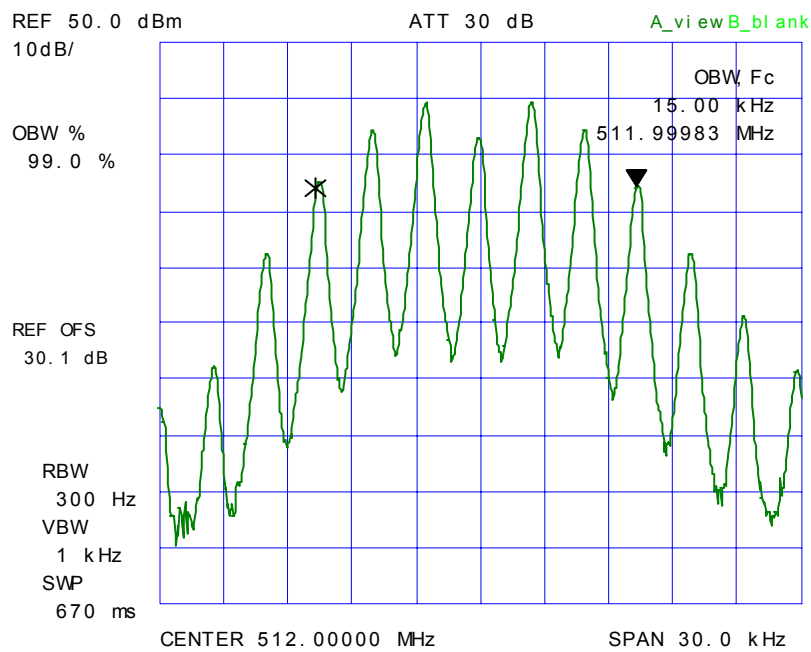

PLOT # 109 99% Occupied Bandwidth – RF Input Signal
Frequency: 512 MHz, 12.5 kHz Channel Spacing
Modulation: Digital

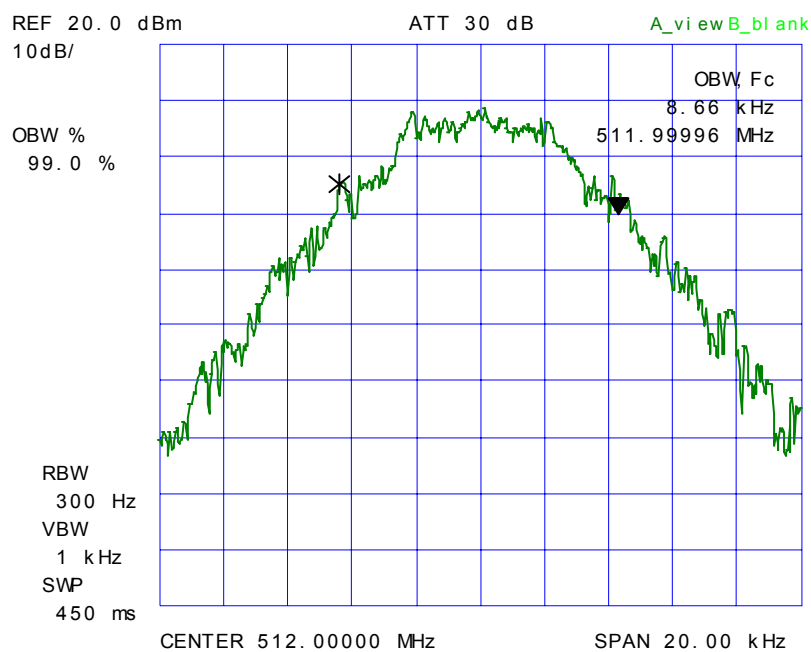

PLOT # 110 99% Occupied Bandwidth – RF Output Signal
Frequency: 512 MHz, 12.5 kHz Channel Spacing
Modulation: Digital

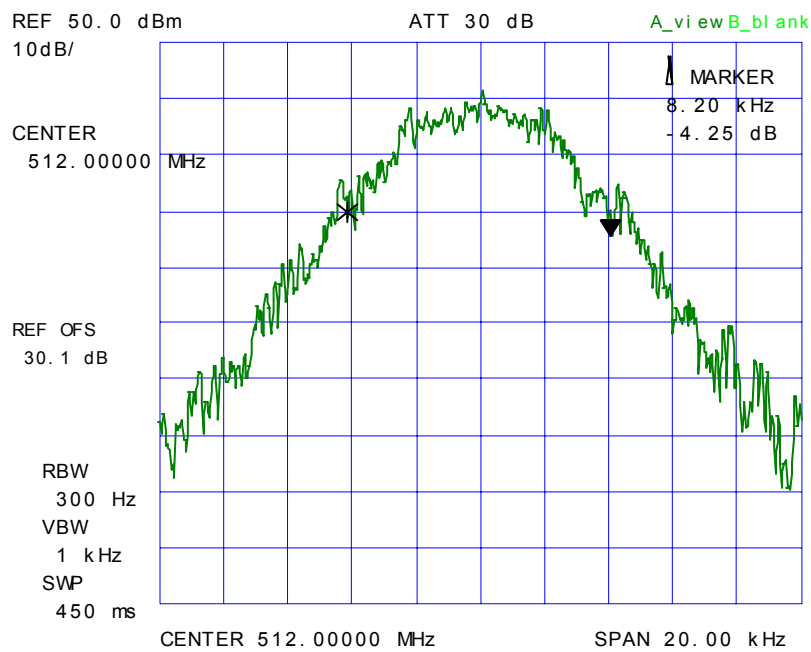

PLOT # 111 99% Occupied Bandwidth – RF Input Signal
Frequency: 512 MHz, 25 kHz Channel Spacing
Modulation: Digital

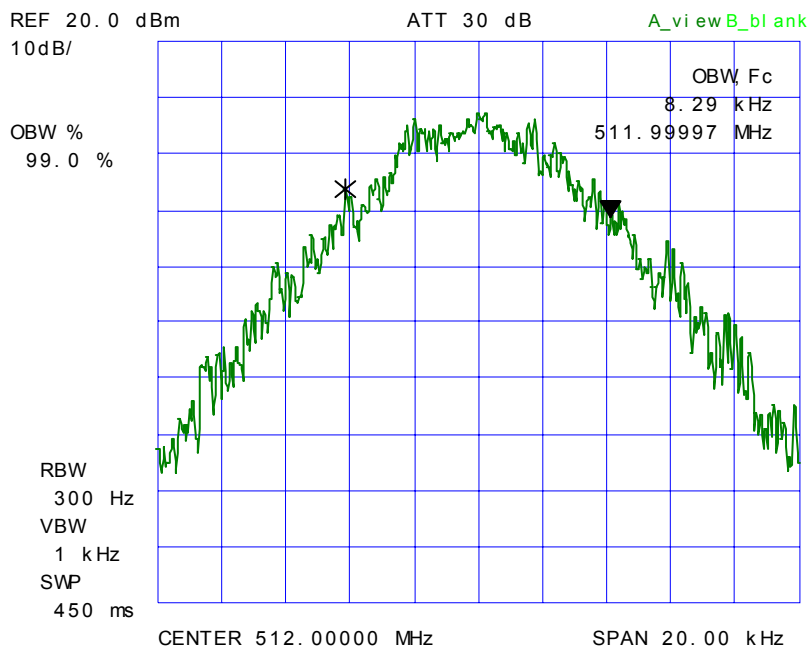

PLOT # 112 99% Occupied Bandwidth – RF Output Signal
Frequency: 512 MHz, 25 kHz Channel Spacing
Modulation: Digital

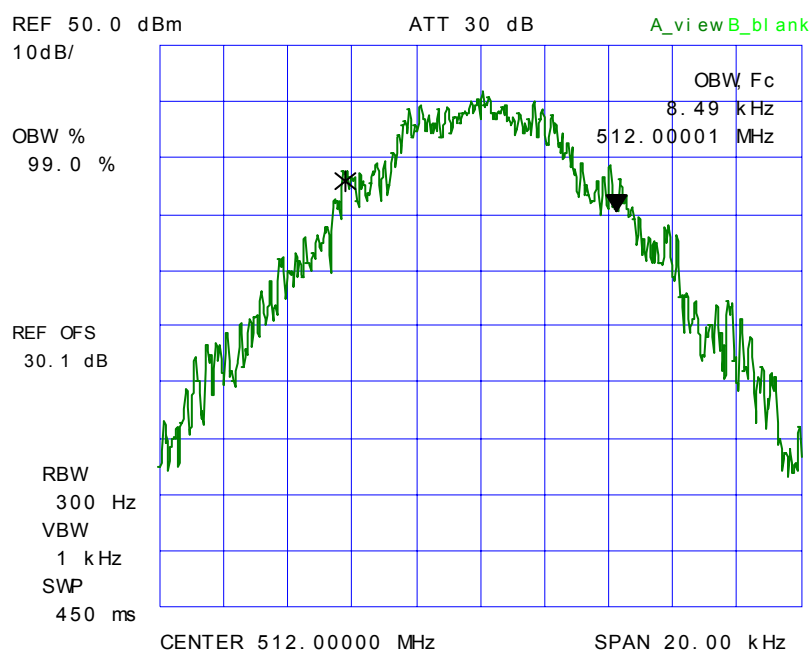

5.10.4.3. Emission Masks

PLOT # 113 Emission Mask B
Frequency: 380 MHz, High Power, 25 kHz Channel Spacing
Modulation: FM modulation with 2.5 kHz sine wave signal

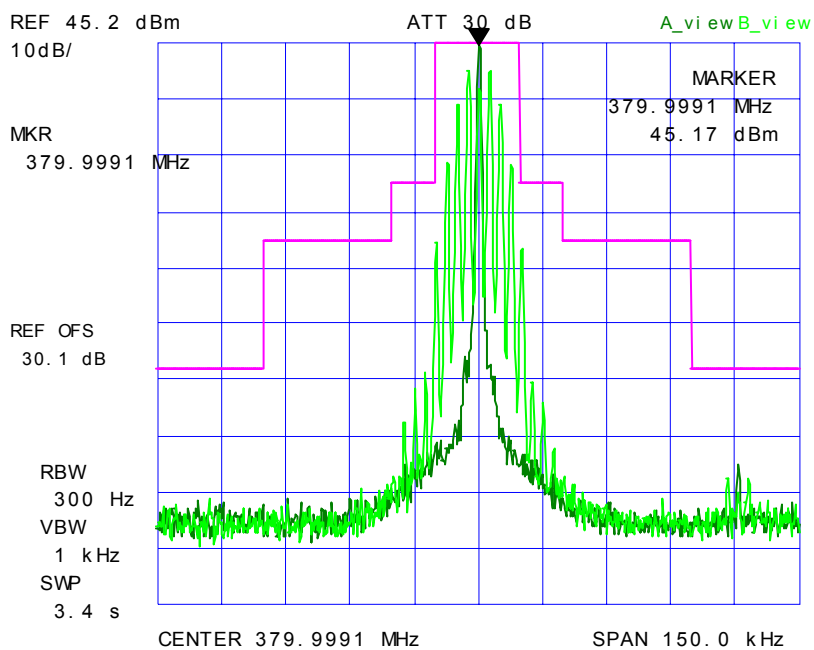

PLOT # 114 Emission Mask B
Frequency: 380 MHz, Low Power, 25 kHz Channel Spacing
Modulation: FM modulation with 2.5 kHz sine wave signal

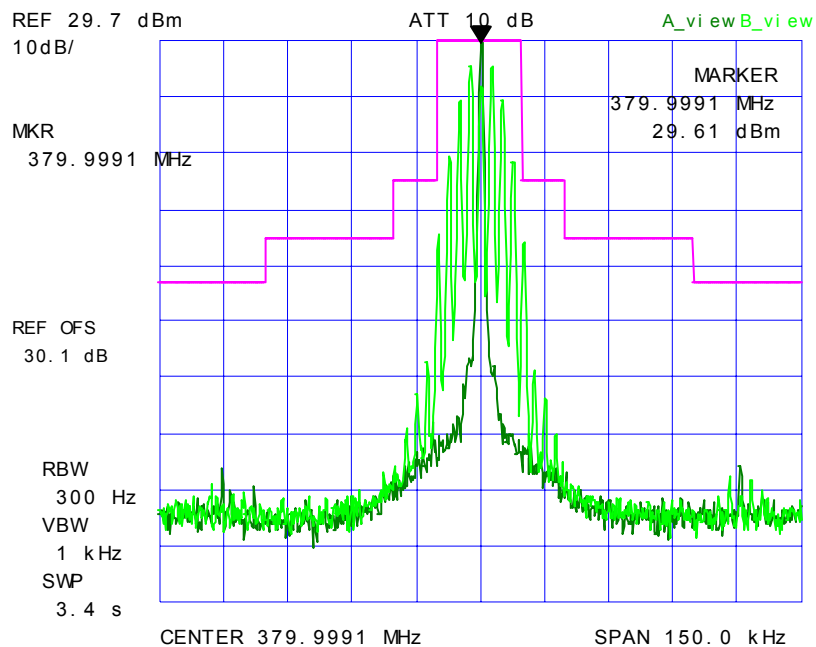

PLOT # 115 Emission Mask B
Frequency: 391.5 MHz, High Power, 25 kHz Channel Spacing
Modulation: FM modulation with 2.5 kHz sine wave signal

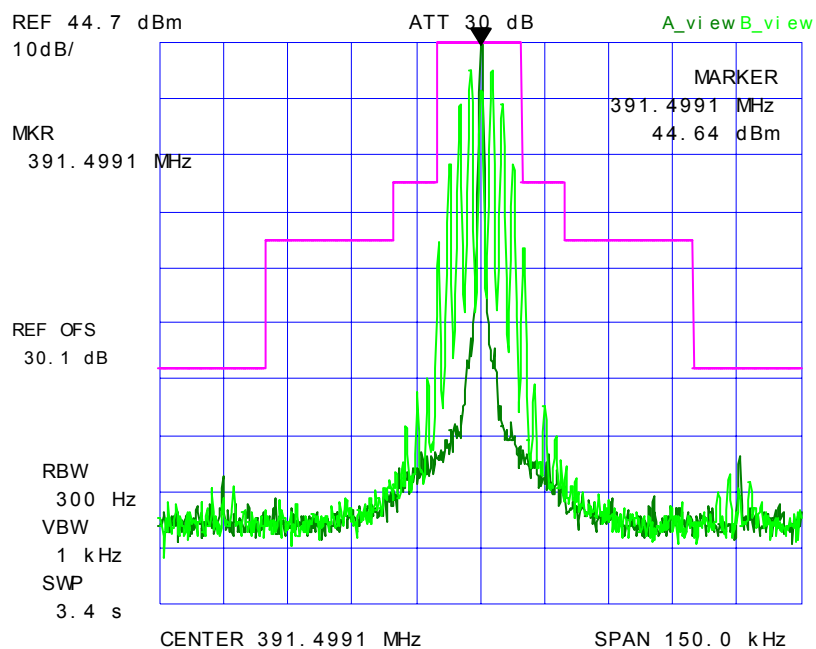

PLOT # 116 Emission Mask B
Frequency: 391.5 MHz, Low Power, 25 kHz Channel Spacing
Modulation: FM modulation with 2.5 kHz sine wave signal

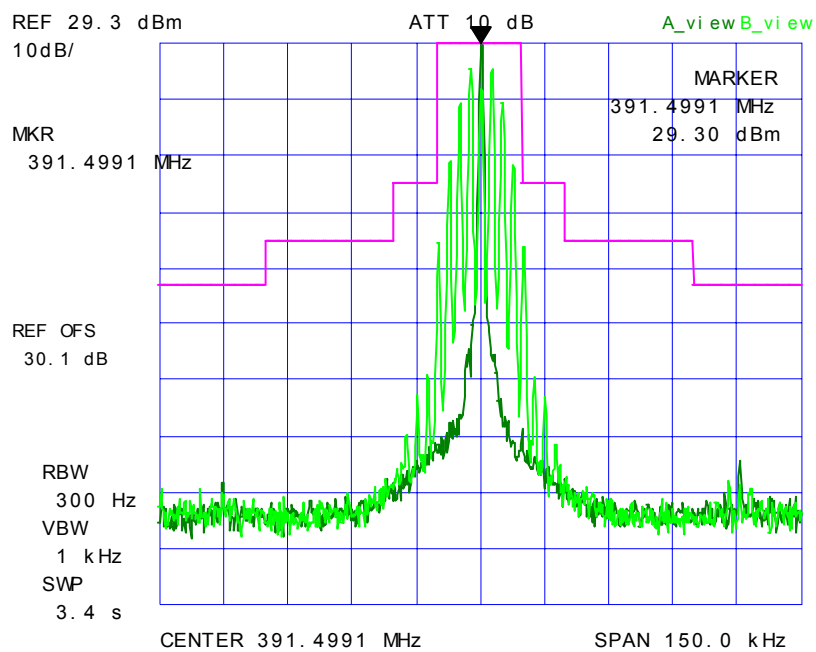

PLOT # 117 Emission Mask B
Frequency: 403 MHz, High Power, 25 kHz Channel Spacing
Modulation: FM modulation with 2.5 kHz sine wave signal

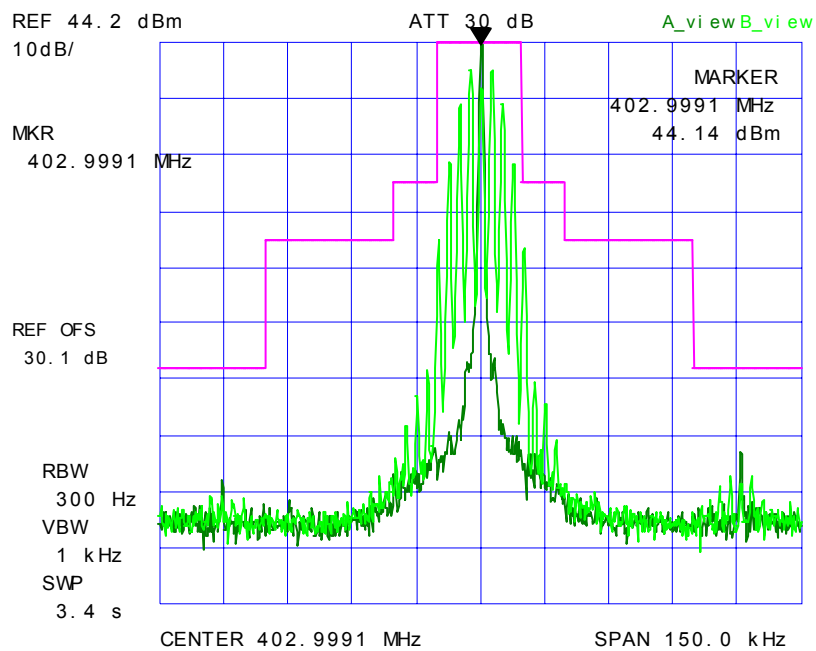

PLOT # 118 Emission Mask B
Frequency: 403 MHz, Low Power, 25 kHz Channel Spacing
Modulation: FM modulation with 2.5 kHz sine wave signal

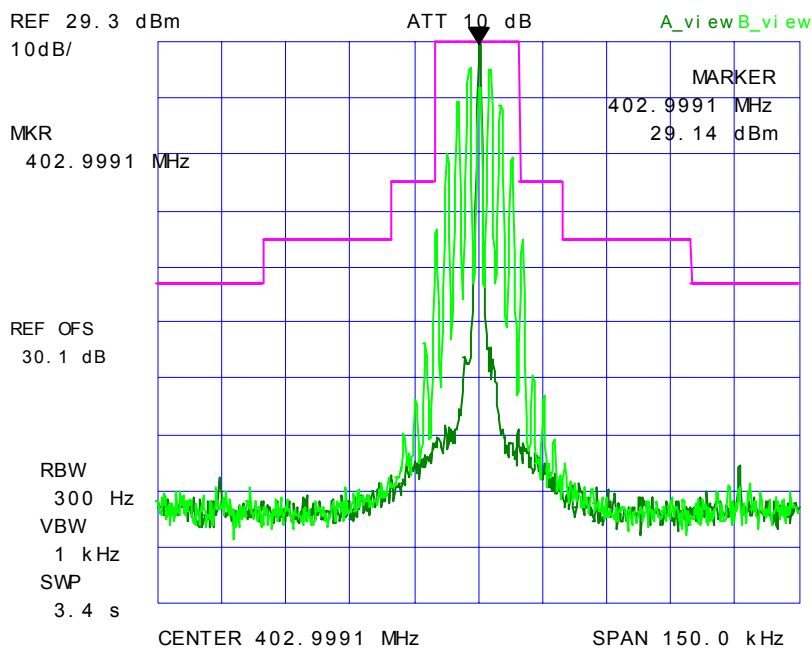

PLOT # 119 Emission Mask C
Frequency: 380 MHz, High Power, 25 kHz Channel Spacing
Modulation: Digital

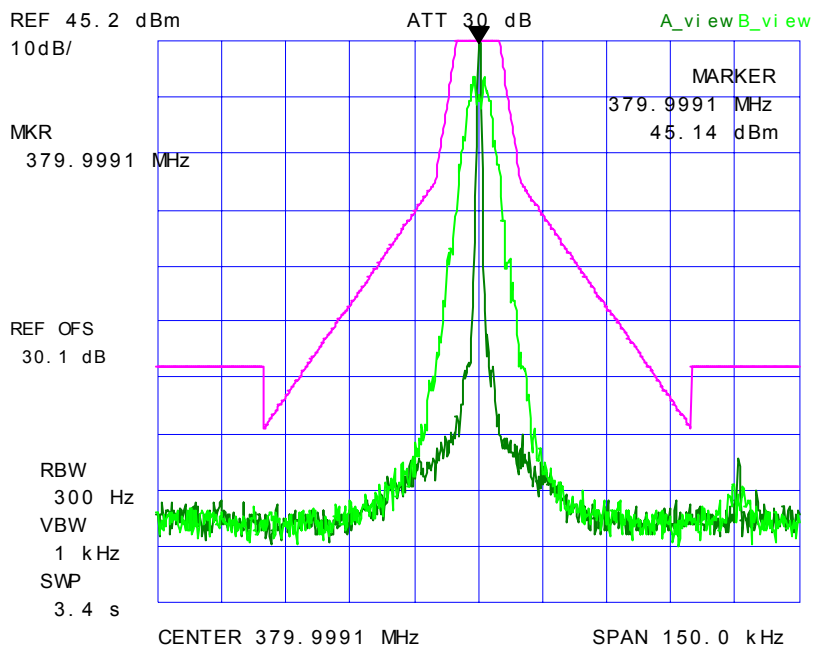

PLOT # 120 Emission Mask C
Frequency: 380 MHz, Low Power, 25 kHz Channel Spacing
Modulation: Digital

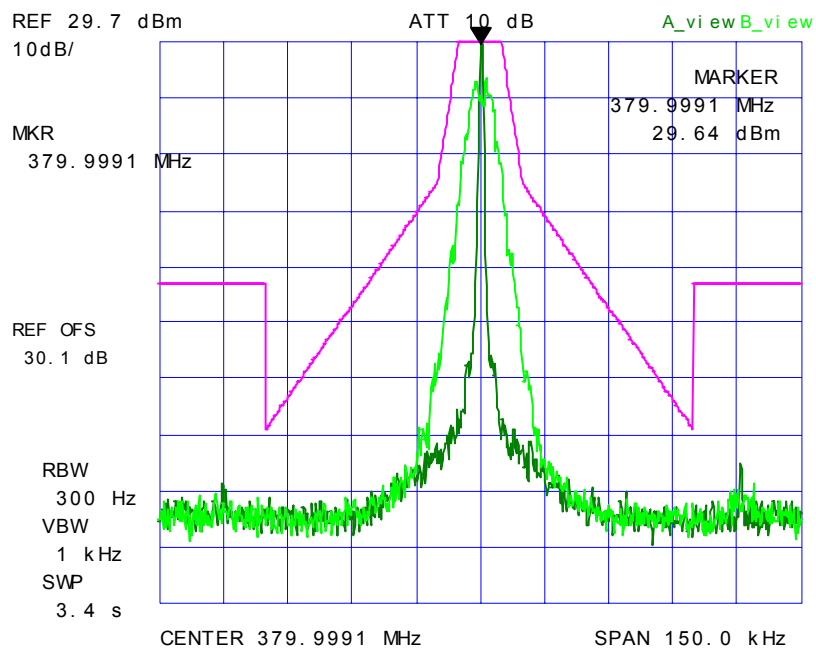

PLOT # 121 Emission Mask C
Frequency: 391.5 MHz, High Power, 25 kHz Channel Spacing
Modulation: Digital

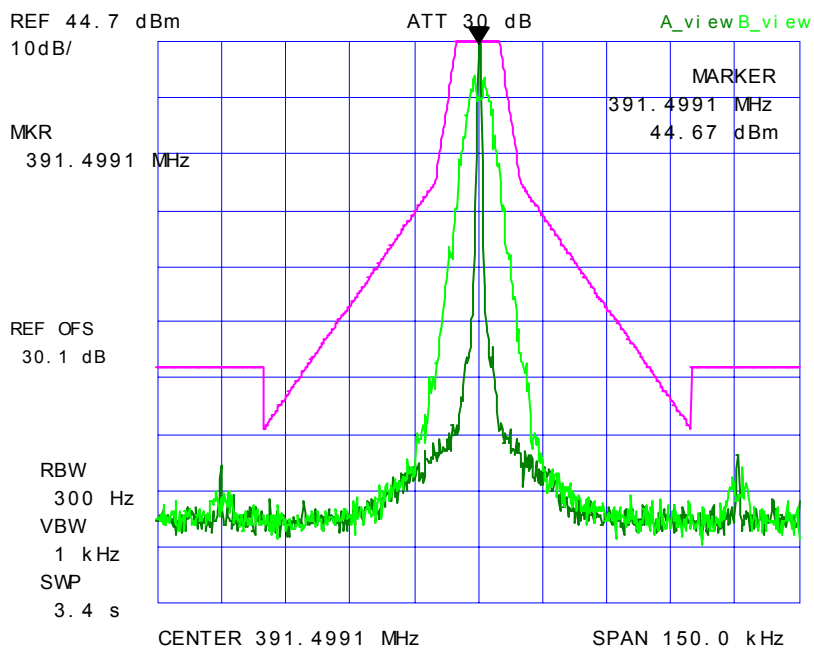

PLOT # 122 Emission Mask C
Frequency: 391.5 MHz, Low Power, 25 kHz Channel Spacing
Modulation: Digital

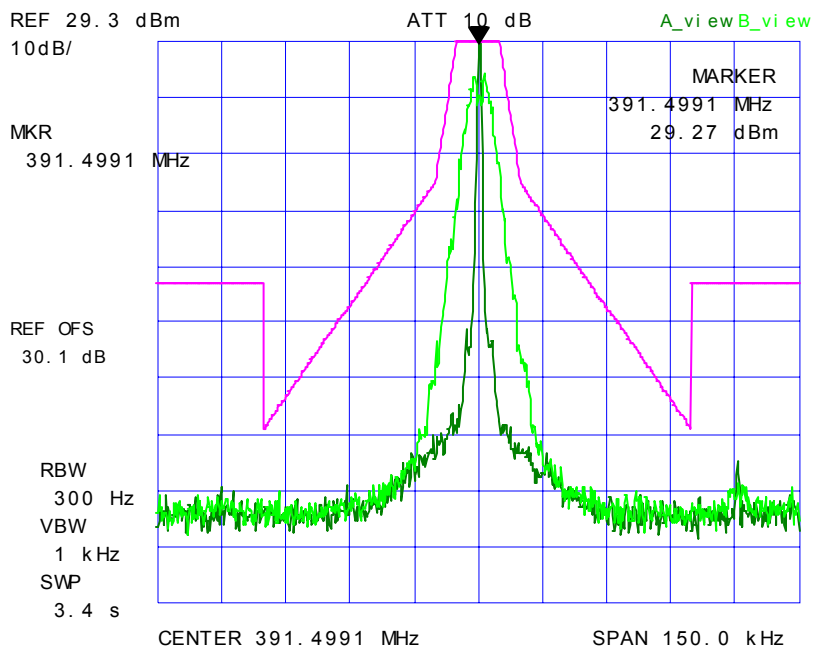

PLOT # 123 Emission Mask C
Frequency: 403 MHz, High Power, 25 kHz Channel Spacing
Modulation: Digital

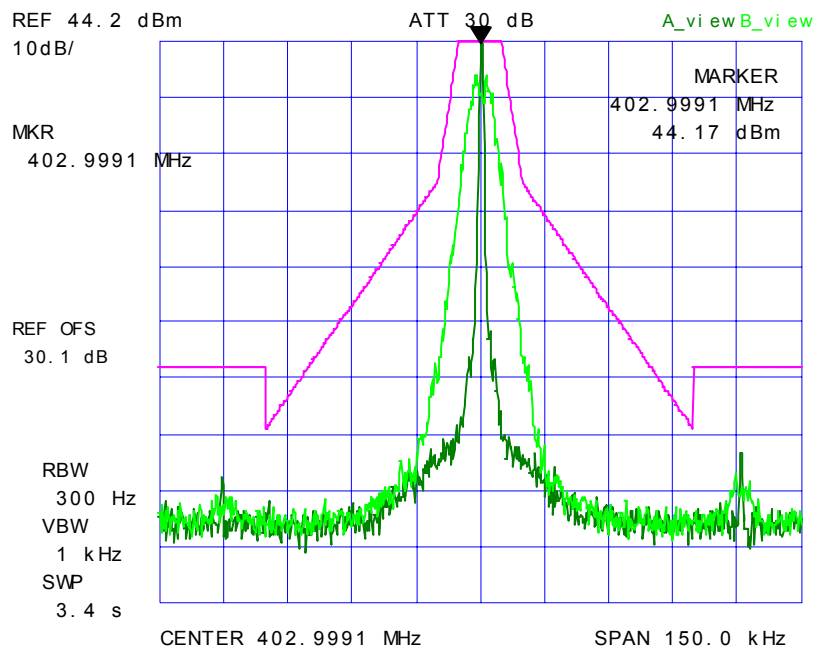

PLOT # 124 Emission Mask C
Frequency: 403 MHz, Low Power, 25 kHz Channel Spacing
Modulation: Digital

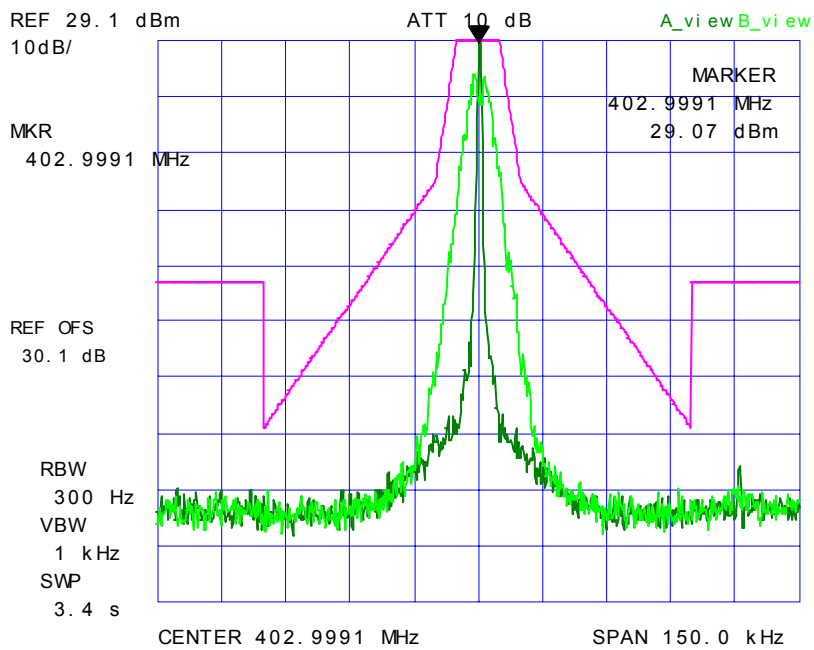

PLOT # 125 Emission Mask D
Frequency: 380 MHz, High Power, 12.5 kHz Channel Spacing
Modulation: FM modulation with 2.5 kHz sine wave signal

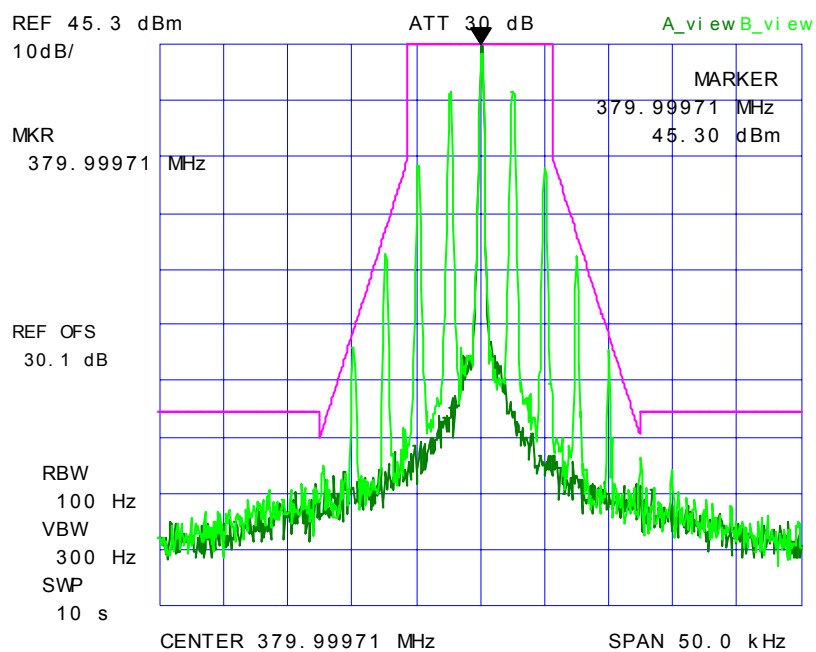

PLOT # 126 Emission Mask D
Frequency: 380 MHz, Low Power, 12.5 kHz Channel Spacing
Modulation: FM modulation with 2.5 kHz sine wave signal

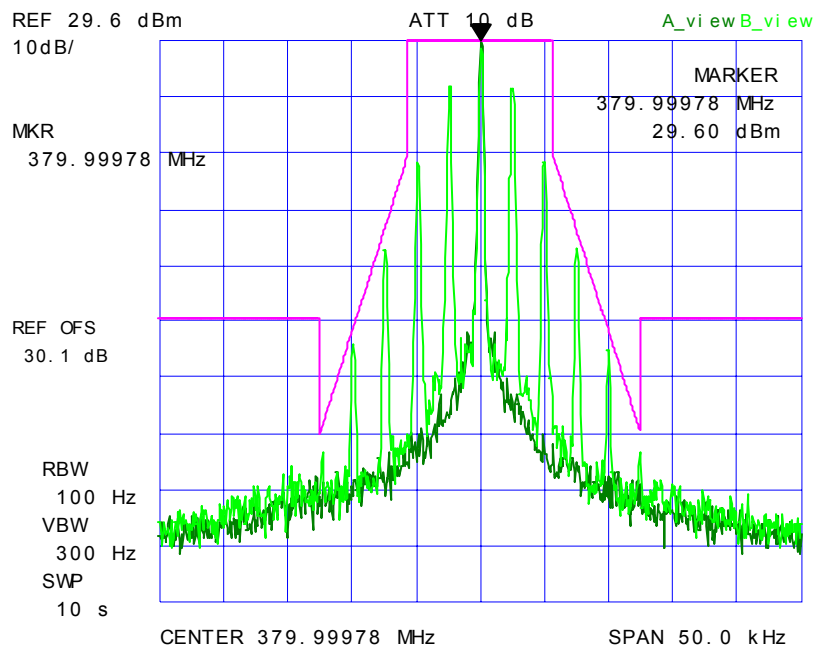

PLOT # 127 Emission Mask D
Frequency: 391.5 MHz, High Power, 12.5 kHz Channel Spacing
Modulation: FM modulation with 2.5 kHz sine wave signal

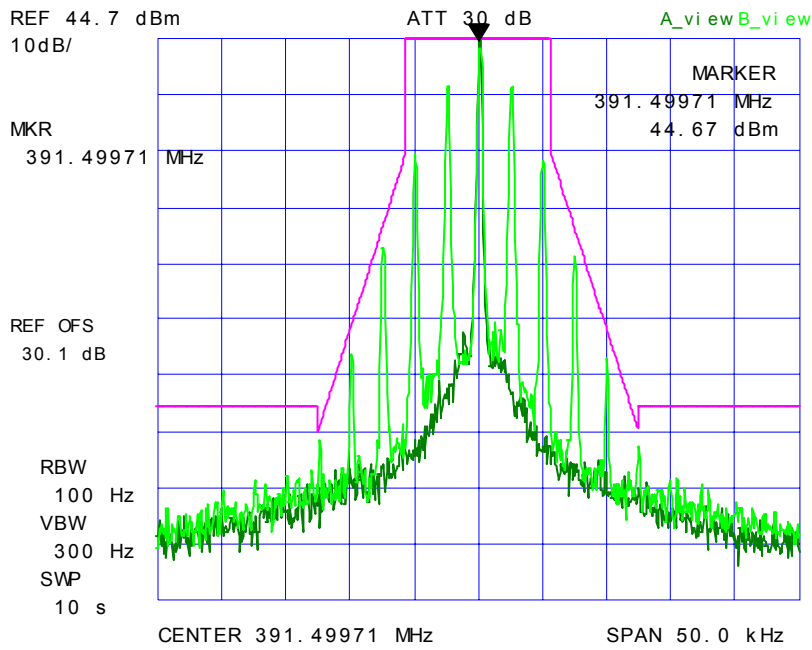

PLOT # 128 Emission Mask D
Frequency: 391.5 MHz, Low Power, 12.5 kHz Channel Spacing
Modulation: FM modulation with 2.5 kHz sine wave signal

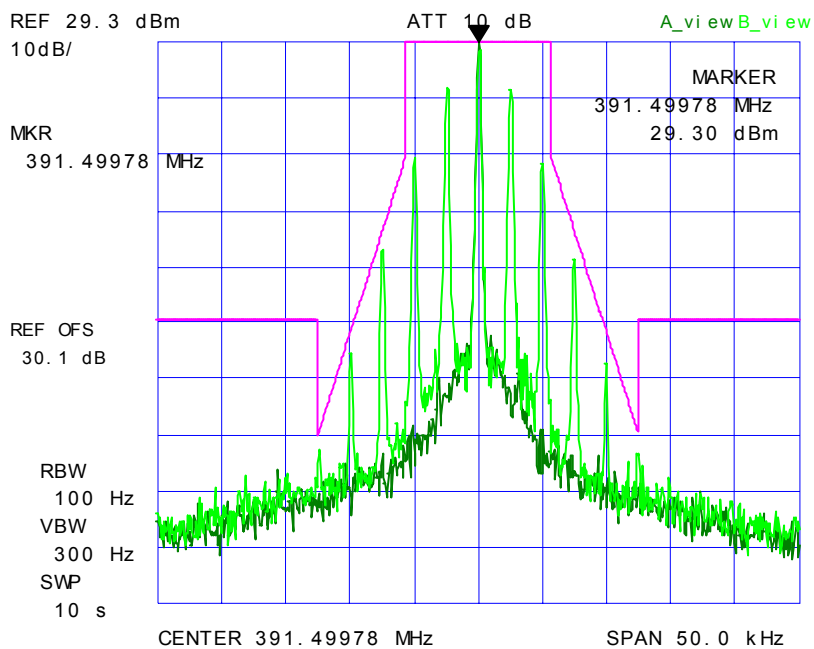

PLOT # 129 Emission Mask D
Frequency: 403 MHz, High Power, 12.5 kHz Channel Spacing
Modulation: FM modulation with 2.5 kHz sine wave signal

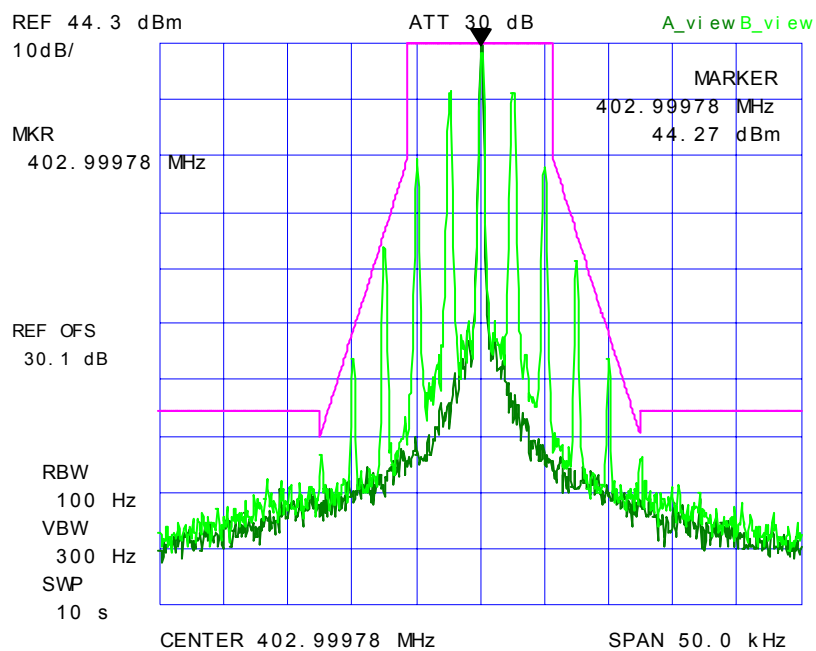

PLOT # 130 Emission Mask D
Frequency: 403 MHz, Low Power, 12.5 kHz Channel Spacing
Modulation: FM modulation with 2.5 kHz sine wave signal

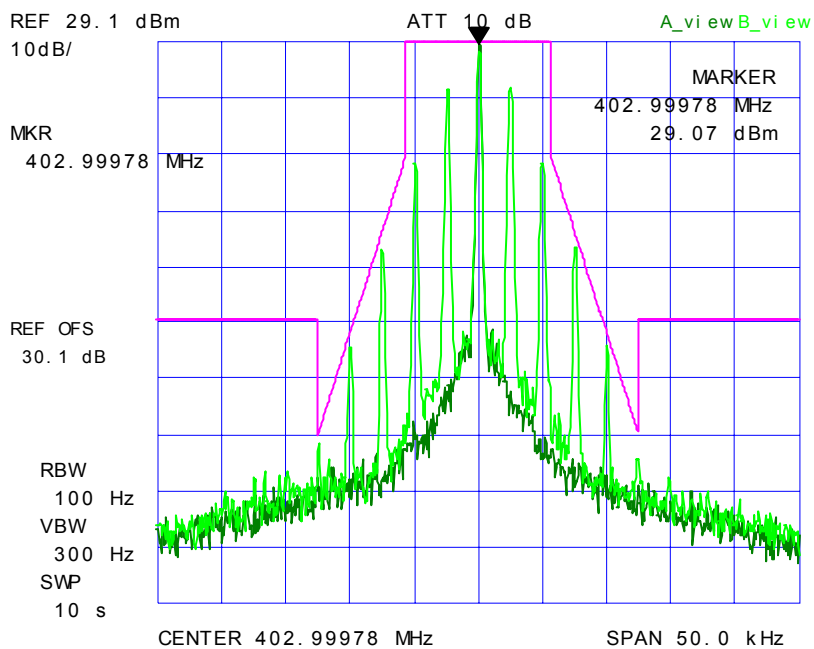

PLOT # 131 Emission Mask D
Frequency: 380 MHz, High Power, 12.5 kHz Channel Spacing
Modulation: Digital

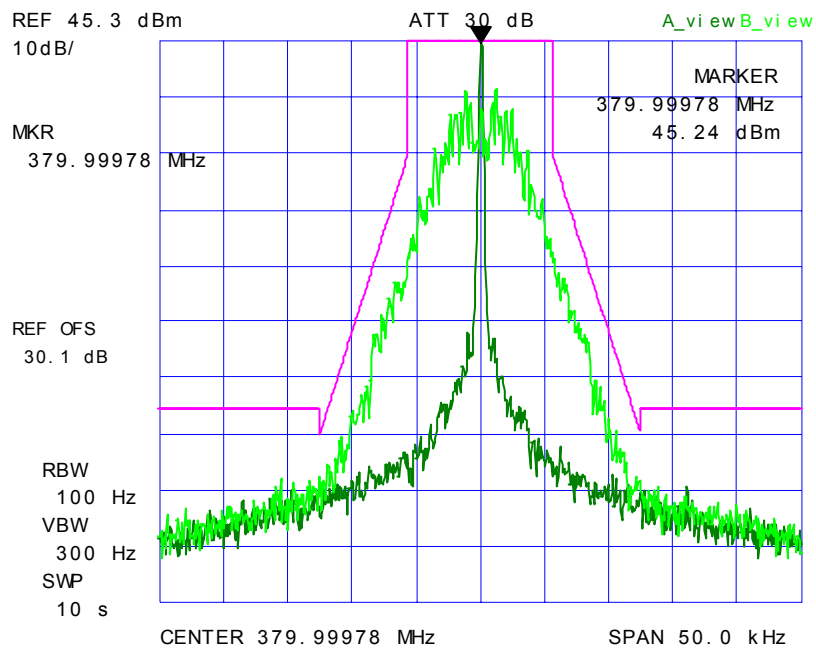

PLOT # 132 Emission Mask D
Frequency: 380 MHz, Low Power, 12.5 kHz Channel Spacing
Modulation: Digital

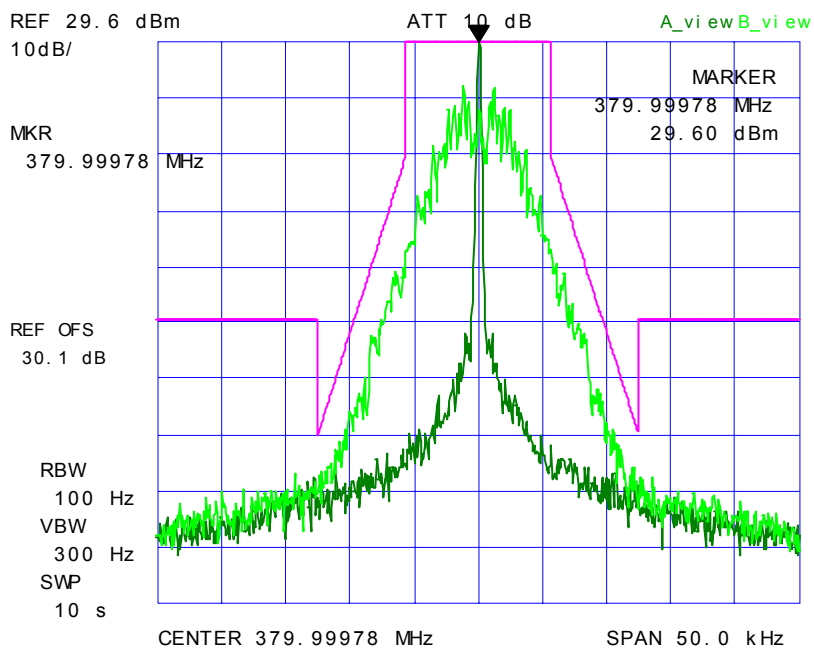

PLOT # 133 Emission Mask D
Frequency: 391.5 MHz, High Power, 12.5 kHz Channel Spacing
Modulation: Digital

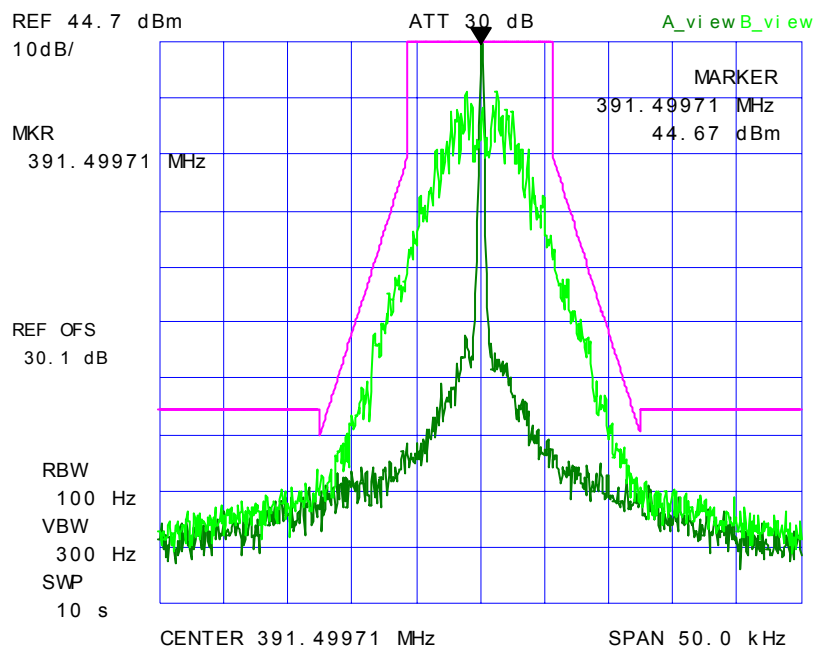

PLOT # 134 Emission Mask D
Frequency: 391.5 MHz, Low Power, 12.5 kHz Channel Spacing
Modulation: Digital

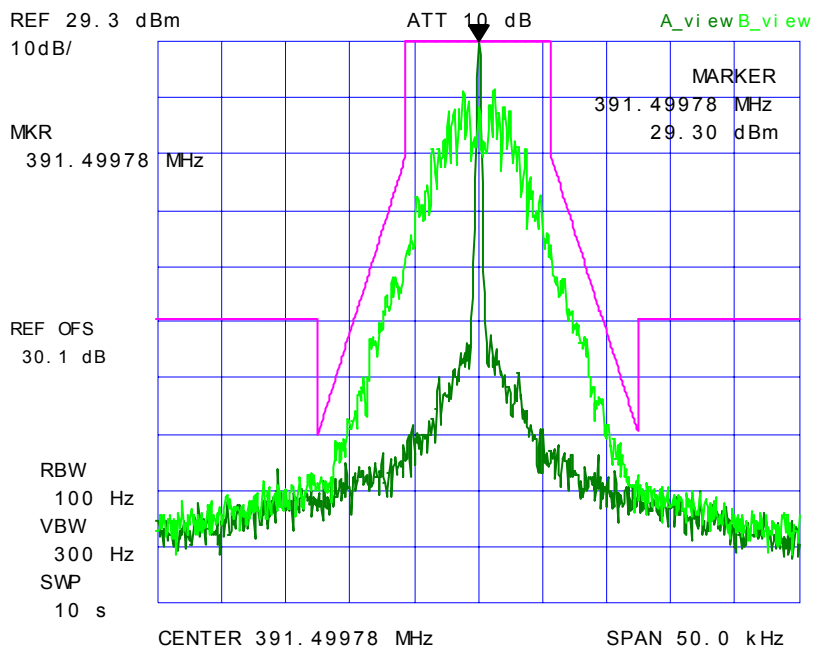

PLOT # 135 Emission Mask D
Frequency: 403 MHz, High Power, 12.5 kHz Channel Spacing
Modulation: Digital

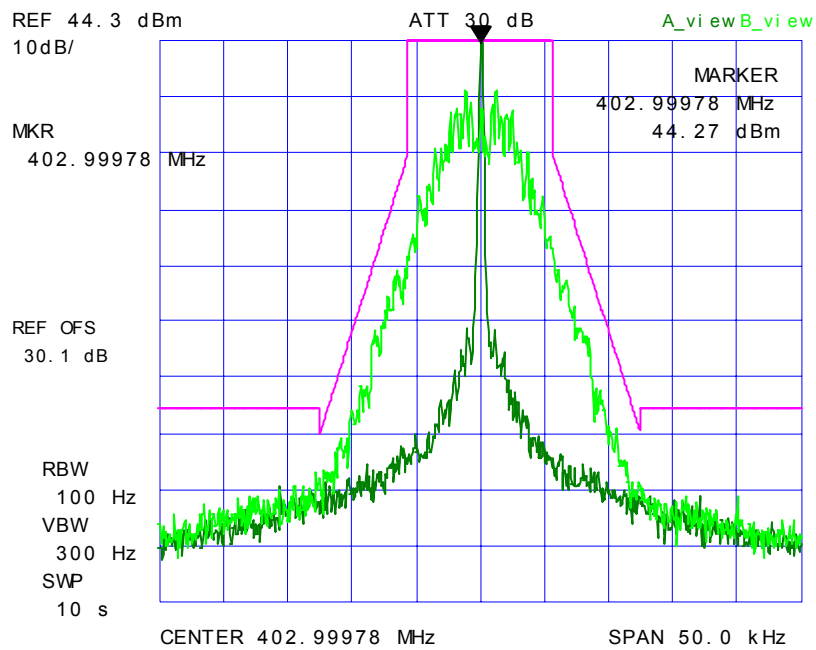

PLOT # 136 Emission Mask D
Frequency: 403 MHz, Low Power, 12.5 kHz Channel Spacing
Modulation: Digital

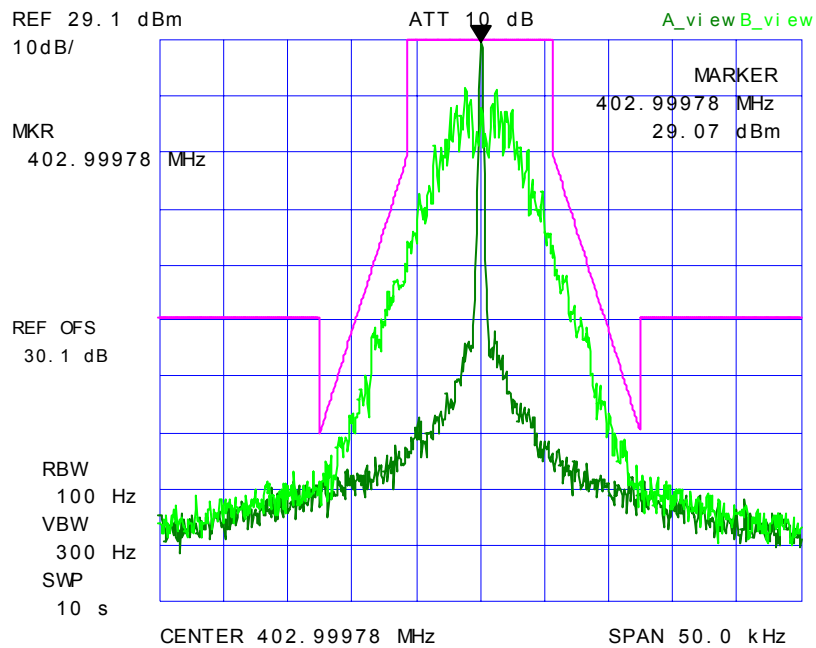

PLOT # 137 Emission Mask B
Frequency: 406.1 MHz, High Power, 25 kHz Channel Spacing
Modulation: FM modulation with 2.5 kHz sine wave signal

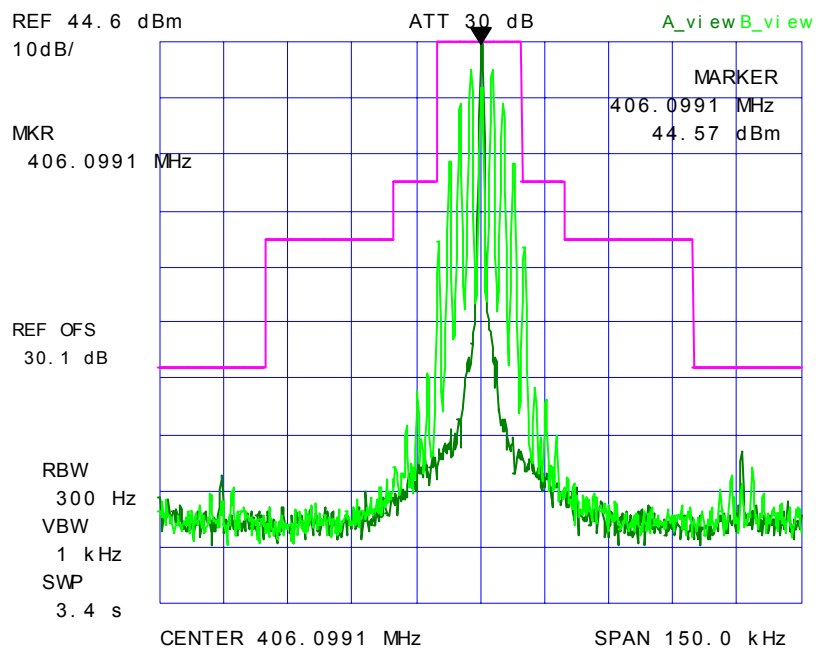

PLOT # 138 Emission Mask B
Frequency: 406.1 MHz, Low Power, 25 kHz Channel Spacing
Modulation: FM modulation with 2.5 kHz sine wave signal

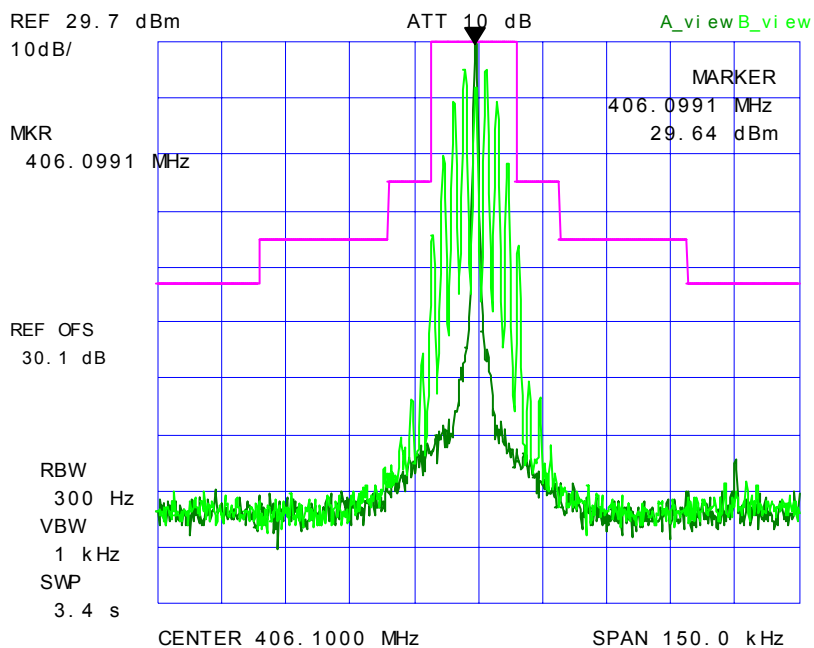

PLOT # 139 Emission Mask B
Frequency: 418.05 MHz, High Power, 25 kHz Channel Spacing
Modulation: FM modulation with 2.5 kHz sine wave signal

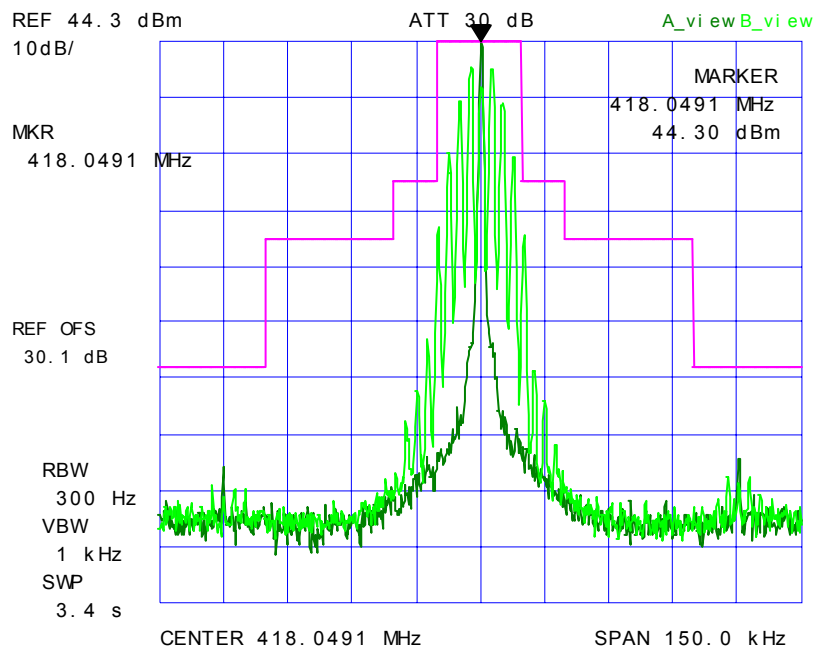

PLOT # 140 Emission Mask B
Frequency: 418.05 MHz, Low Power, 25 kHz Channel Spacing
Modulation: FM modulation with 2.5 kHz sine wave signal

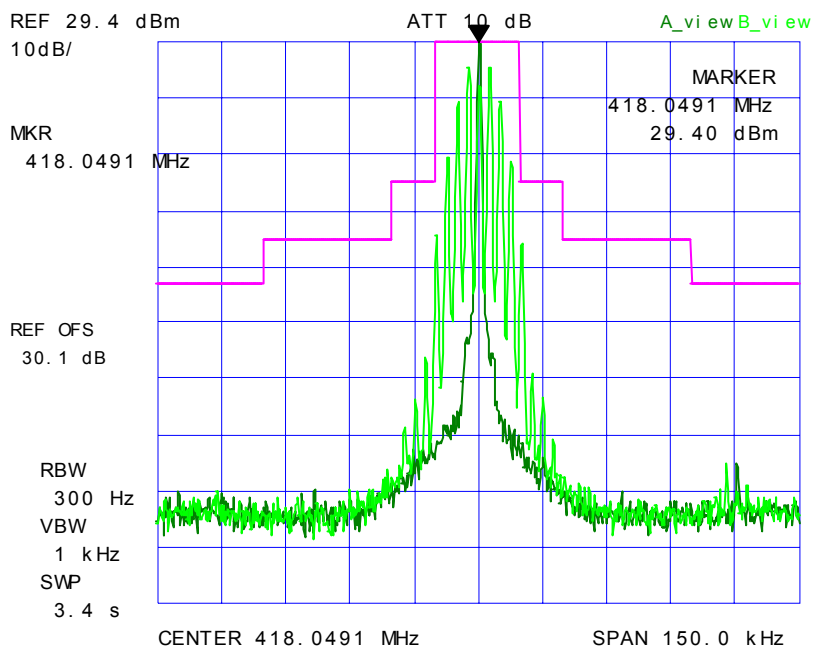

PLOT # 141 Emission Mask B
Frequency: 430 MHz, High Power, 25 kHz Channel Spacing
Modulation: FM modulation with 2.5 kHz sine wave signal

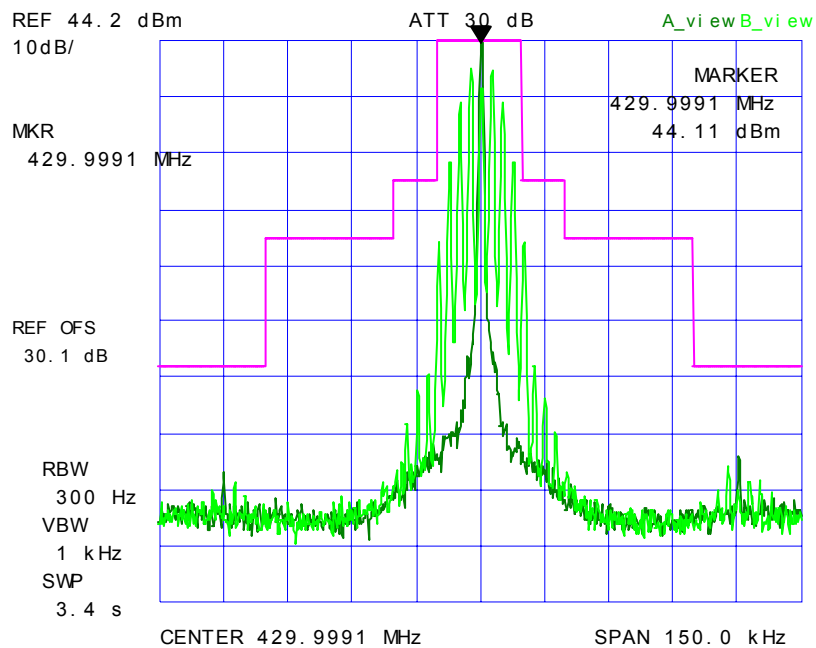

PLOT # 142 Emission Mask B
Frequency: 430 MHz, Low Power, 25 kHz Channel Spacing
Modulation: FM modulation with 2.5 kHz sine wave signal

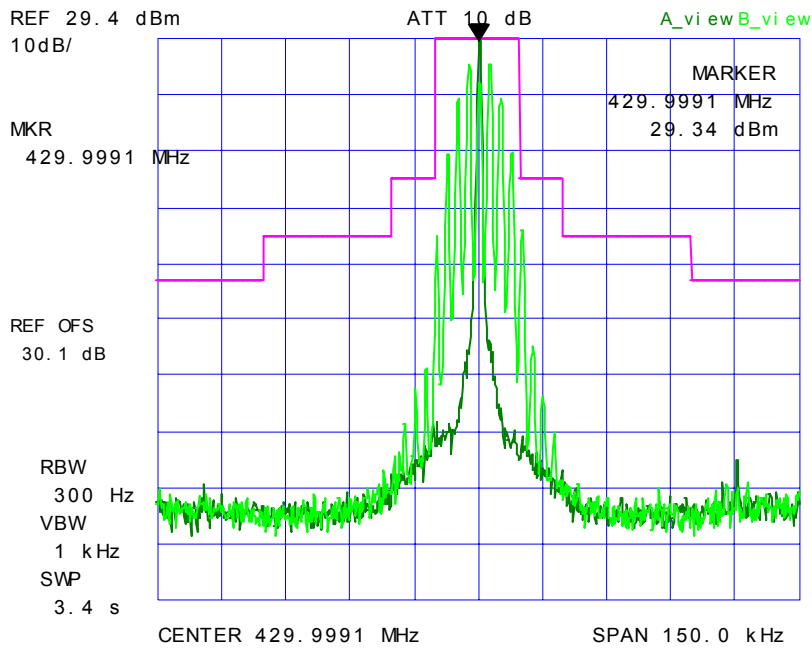

PLOT # 143 Emission Mask C
Frequency: 406.1 MHz, High Power, 25 kHz Channel Spacing
Modulation: Digital

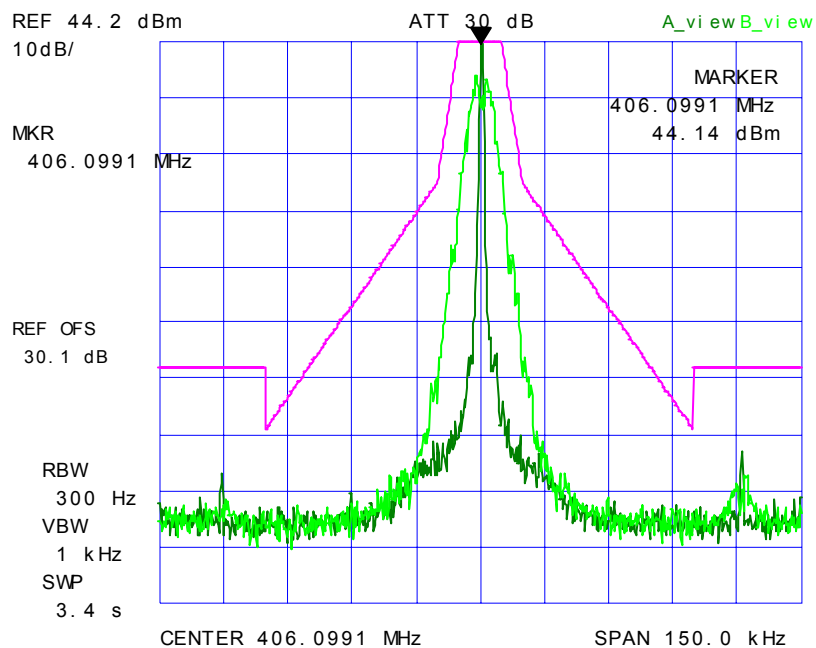

PLOT # 144 Emission Mask C
Frequency: 406.1 MHz, Low Power, 25 kHz Channel Spacing
Modulation: Digital

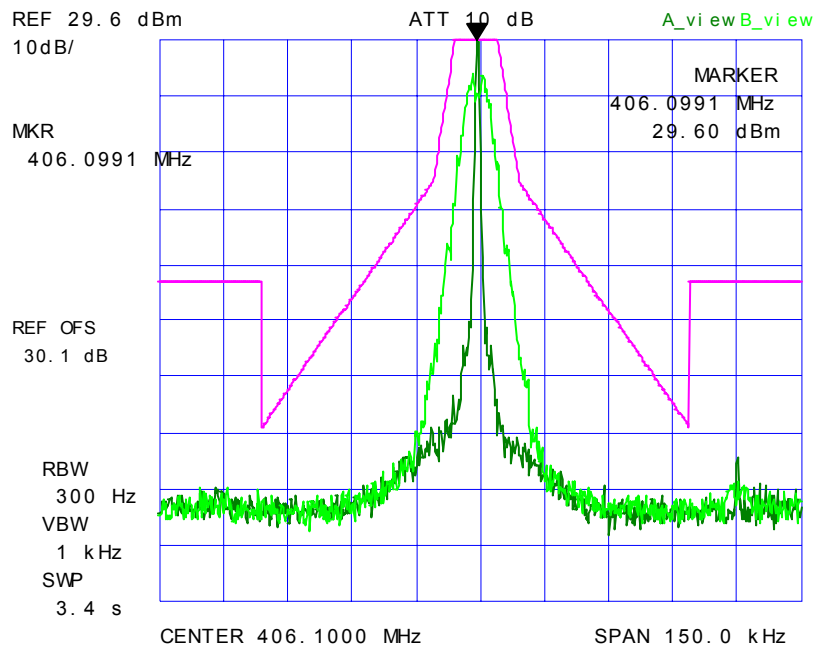

PLOT # 145 Emission Mask C
Frequency: 418.05 MHz, High Power, 25 kHz Channel Spacing
Modulation: Digital

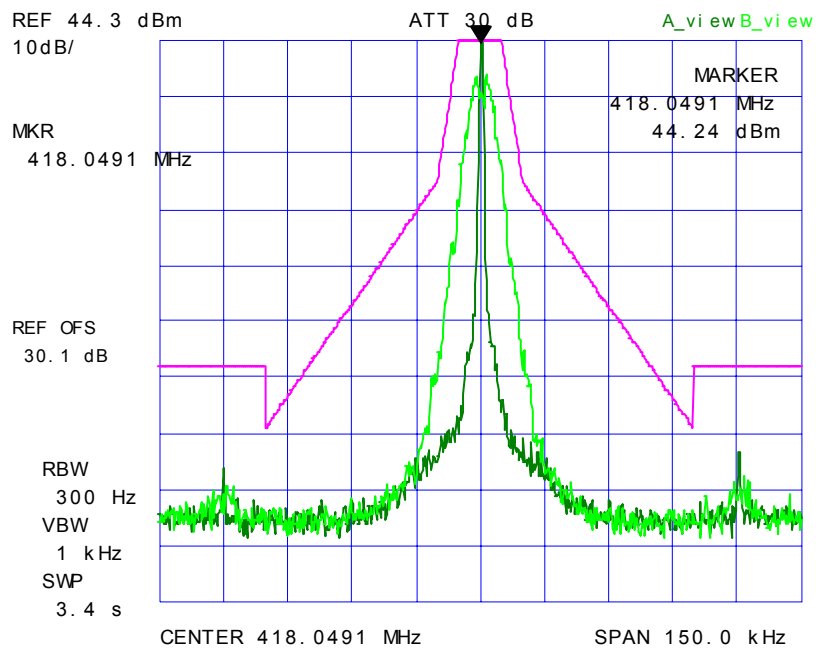

PLOT # 146 Emission Mask C
Frequency: 418.05 MHz, Low Power, 25 kHz Channel Spacing
Modulation: Digital

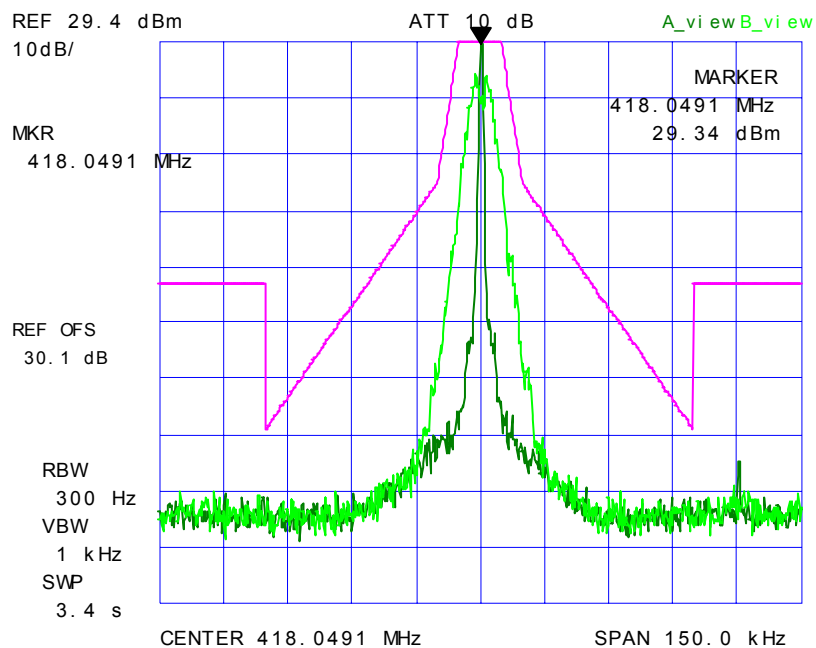

PLOT # 147 Emission Mask C
Frequency: 430 MHz, High Power, 25 kHz Channel Spacing
Modulation: Digital

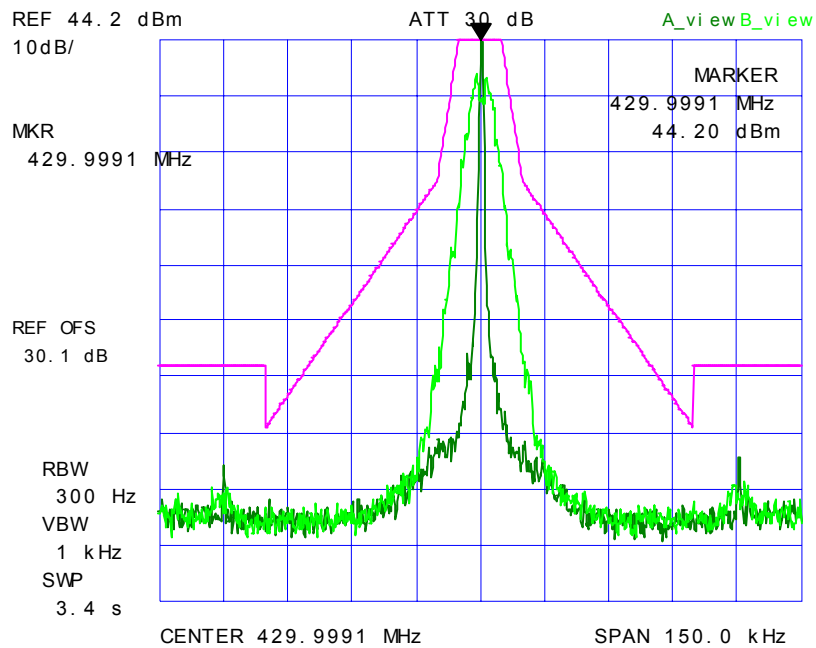

PLOT # 148 Emission Mask C
Frequency: 430 MHz, Low Power, 25 kHz Channel Spacing
Modulation: Digital

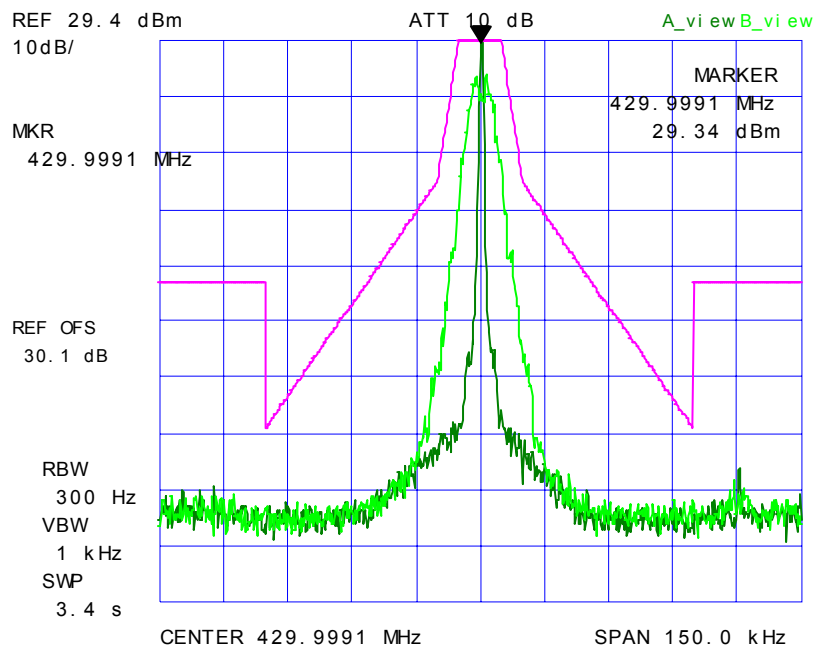

PLOT # 149 Emission Mask D
Frequency: 406.1 MHz, High Power, 12.5 kHz Channel Spacing
Modulation: FM modulation with 2.5 kHz sine wave signal

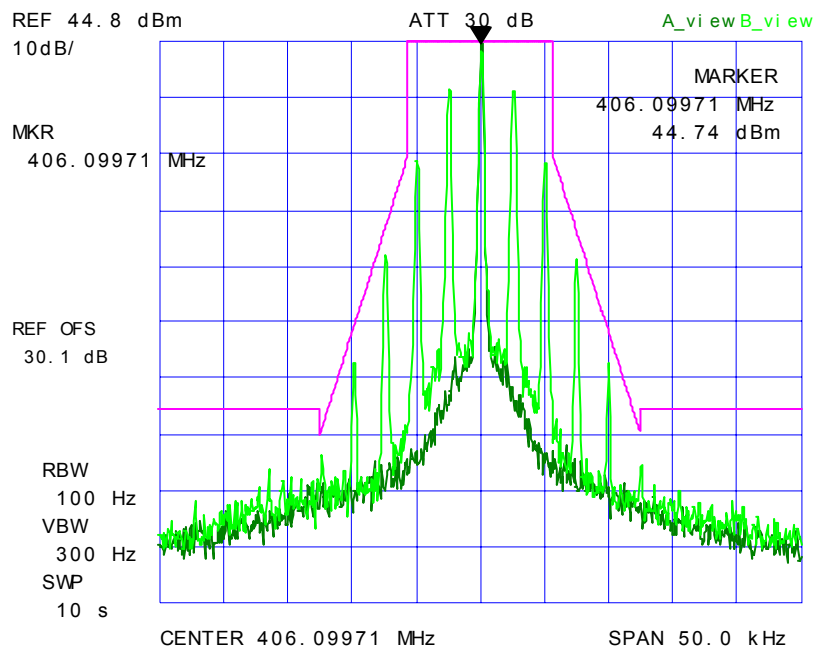

PLOT # 150 Emission Mask D
Frequency: 406.1 MHz, Low Power, 12.5 kHz Channel Spacing
Modulation: FM modulation with 2.5 kHz sine wave signal

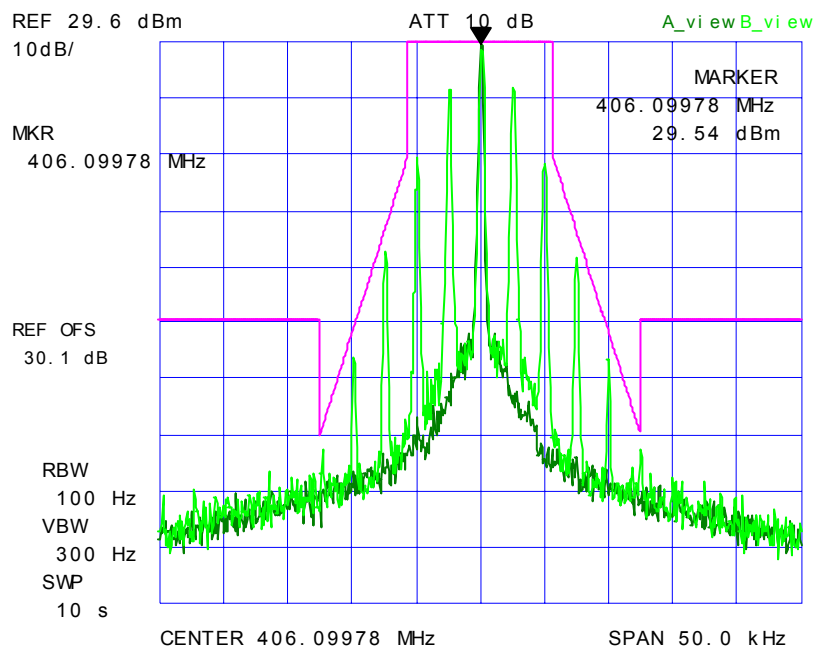

PLOT # 151 Emission Mask D
Frequency: 418.05 MHz, High Power, 12.5 kHz Channel Spacing
Modulation: FM modulation with 2.5 kHz sine wave signal

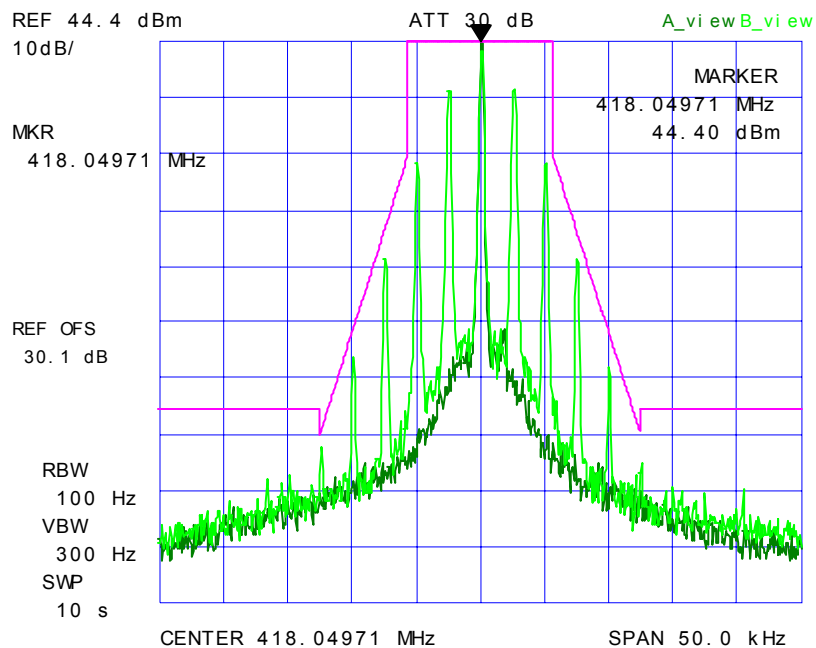

PLOT # 152 Emission Mask D
Frequency: 418.05 MHz, Low Power, 12.5 kHz Channel Spacing
Modulation: FM modulation with 2.5 kHz sine wave signal

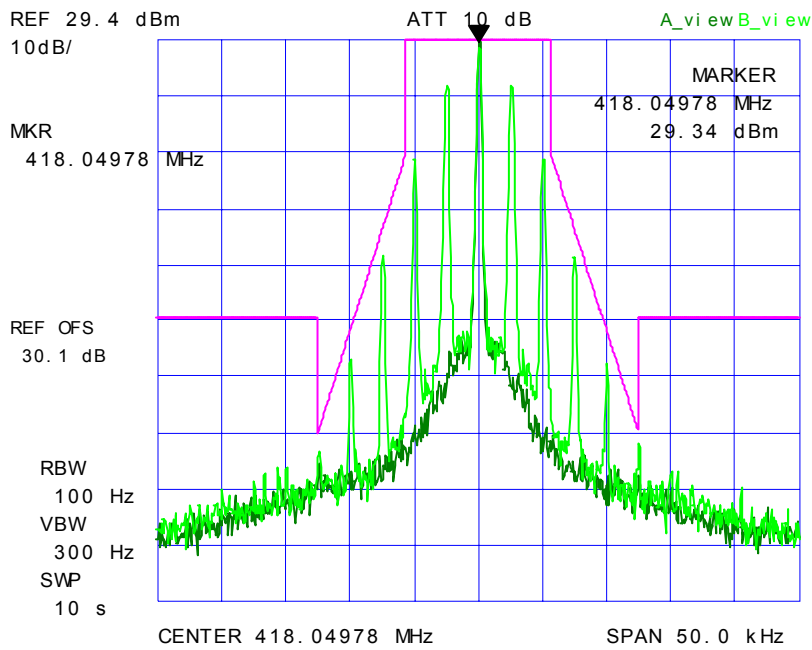

PLOT # 153 Emission Mask D
Frequency: 430 MHz, High Power, 12.5 kHz Channel Spacing
Modulation: FM modulation with 2.5 kHz sine wave signal

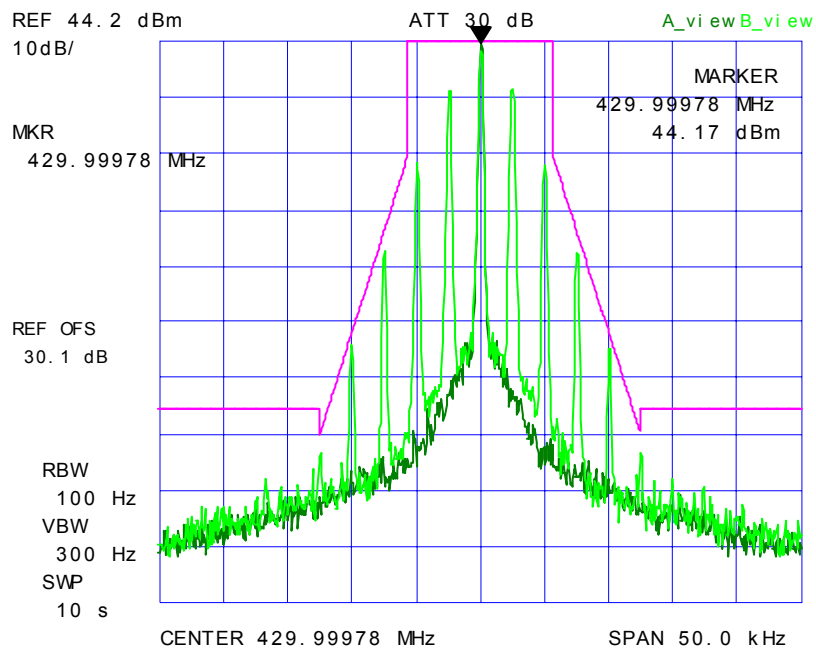

PLOT # 154 Emission Mask D
Frequency: 430 MHz, Low Power, 12.5 kHz Channel Spacing
Modulation: FM modulation with 2.5 kHz sine wave signal

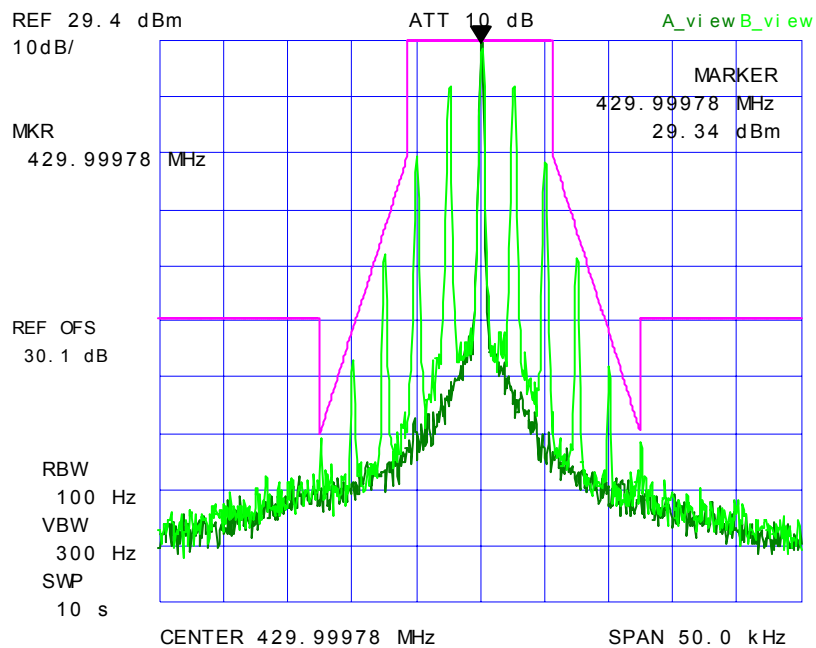

PLOT # 155 Emission Mask D
Frequency: 406.1 MHz, High Power, 12.5 kHz Channel Spacing
Modulation: Digital

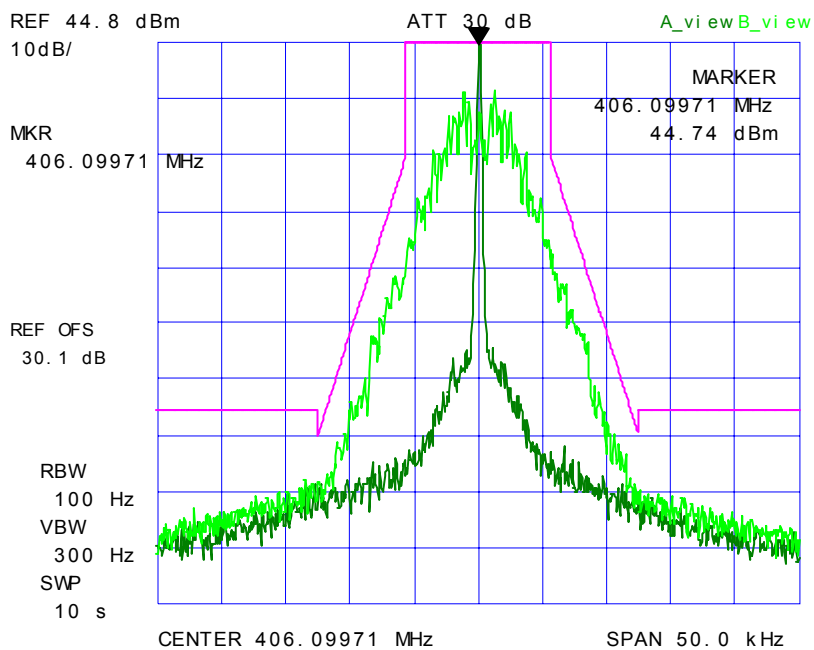

PLOT # 156 Emission Mask D
Frequency: 406.1 MHz, Low Power, 12.5 kHz Channel Spacing
Modulation: Digital

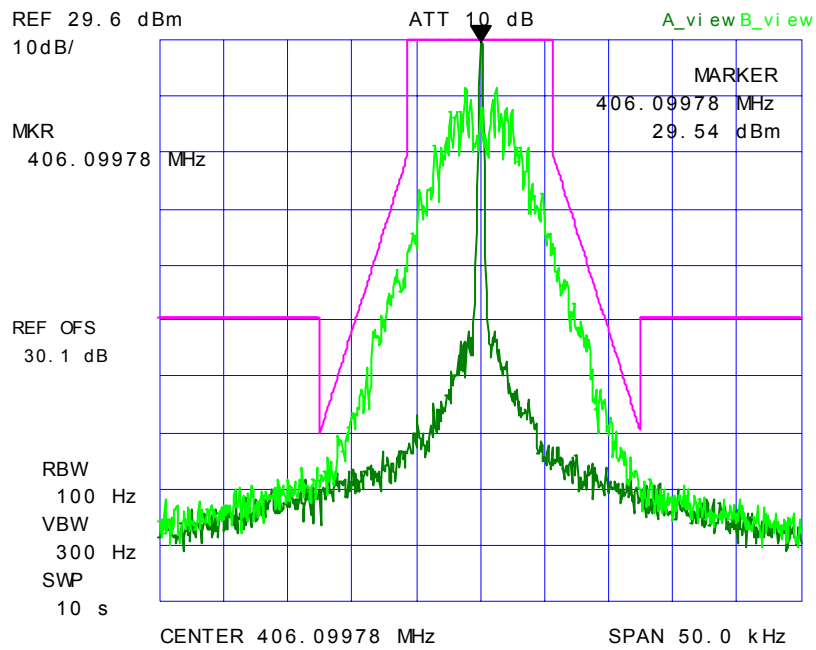

PLOT # 157 Emission Mask D
Frequency: 418.05 MHz, High Power, 12.5 kHz Channel Spacing
Modulation: Digital

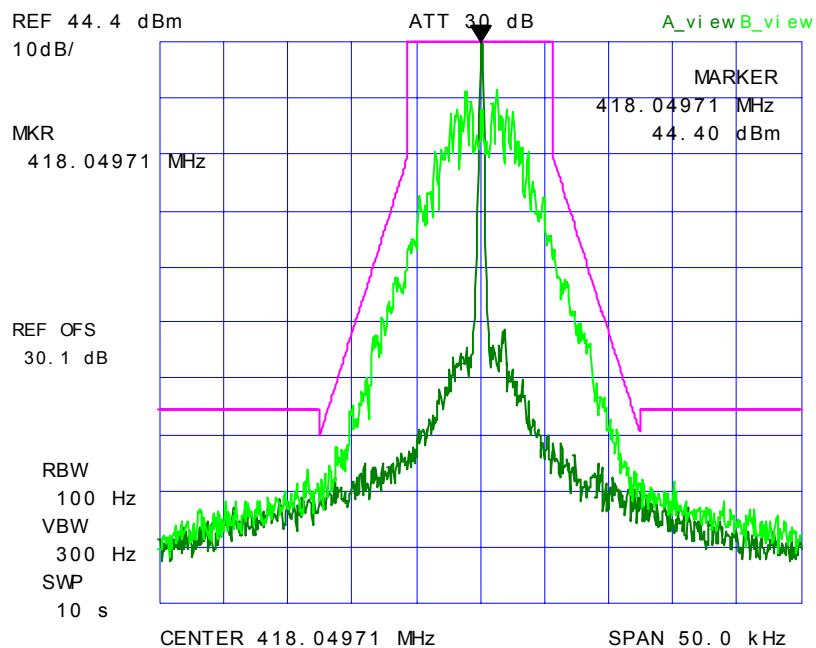

PLOT # 158 Emission Mask D
Frequency: 418.05 MHz, Low Power, 12.5 kHz Channel Spacing
Modulation: Digital

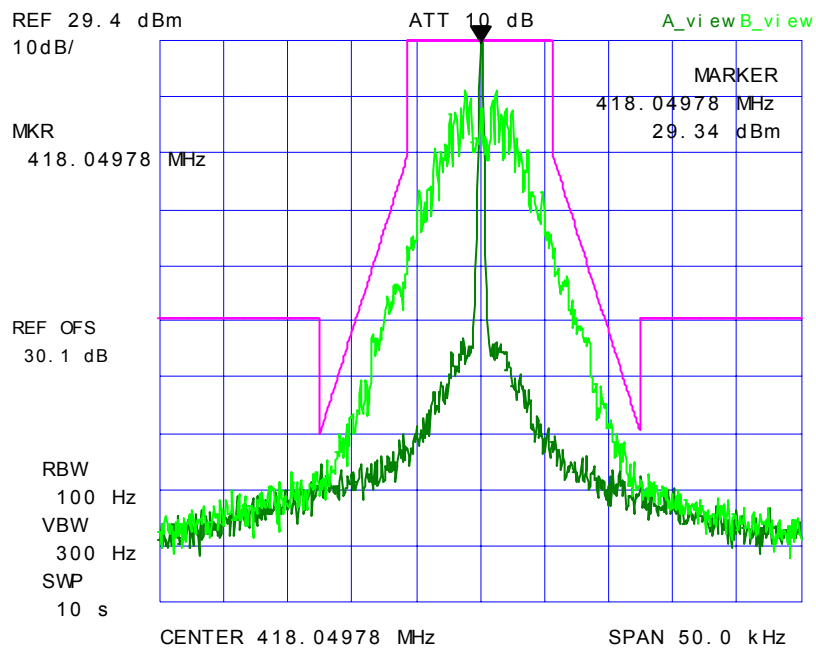

PLOT # 159 Emission Mask D
Frequency: 430 MHz, High Power, 12.5 kHz Channel Spacing
Modulation: Digital

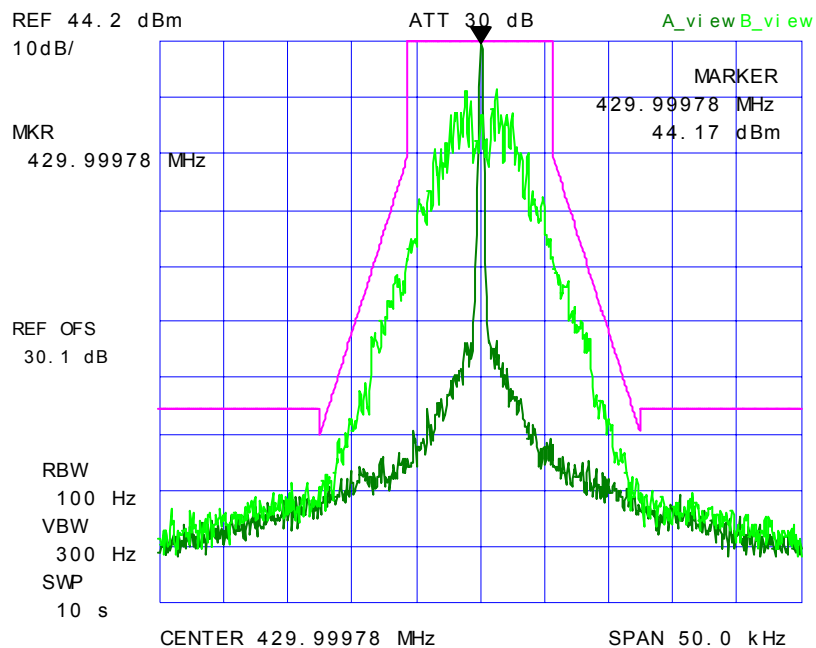

PLOT # 160 Emission Mask D
Frequency: 430 MHz, Low Power, 12.5 kHz Channel Spacing
Modulation: Digital

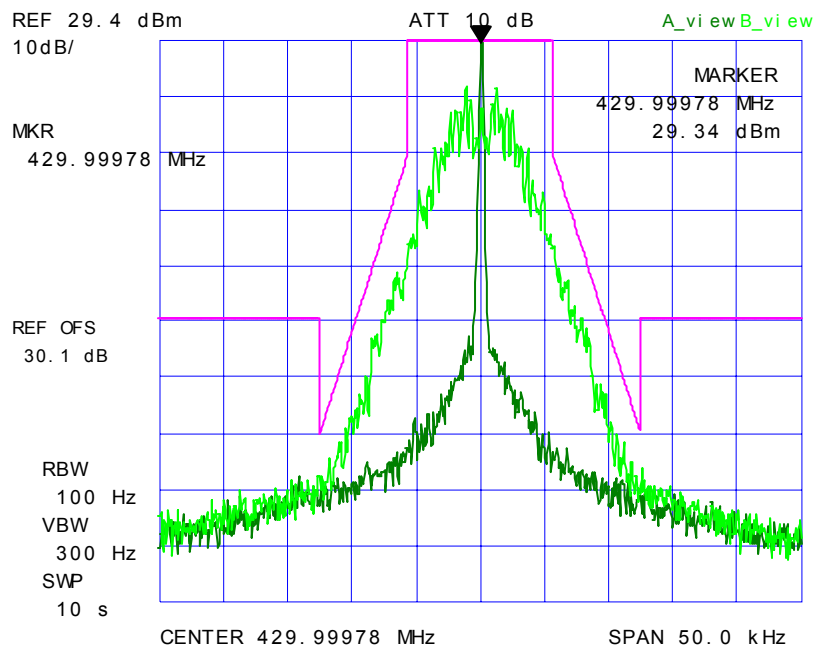

PLOT # 161 Emission Mask B
Frequency: 450 MHz, High Power, 25 kHz Channel Spacing
Modulation: FM modulation with 2.5 kHz sine wave signal

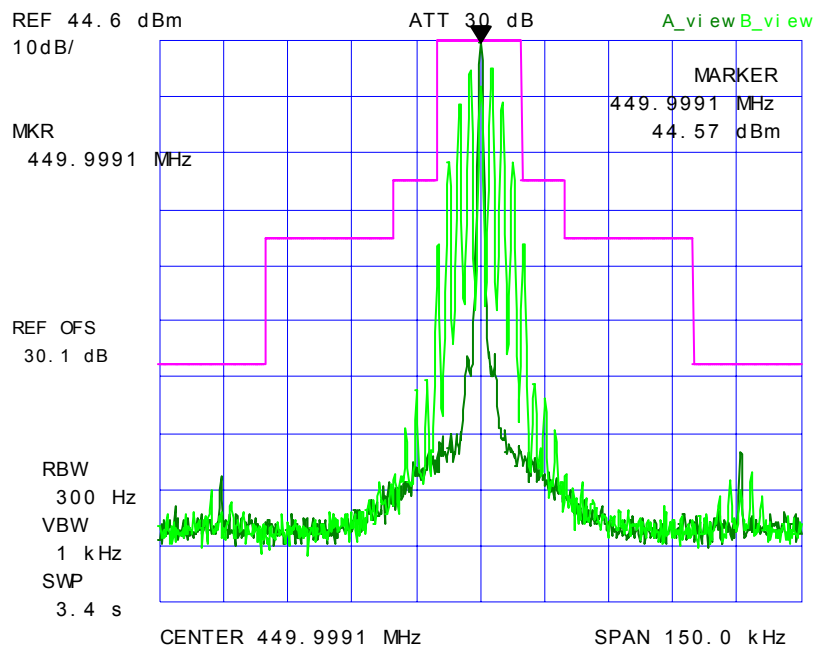

PLOT # 162 Emission Mask B
Frequency: 450 MHz, Low Power, 25 kHz Channel Spacing
Modulation: FM modulation with 2.5 kHz sine wave signal

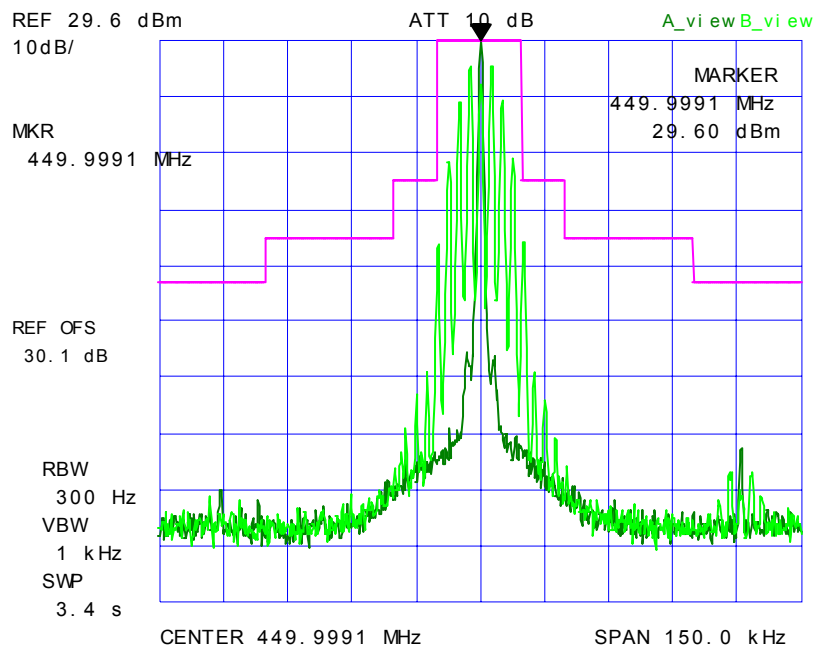

PLOT # 163 Emission Mask B
Frequency: 460 MHz, High Power, 25 kHz Channel Spacing
Modulation: FM modulation with 2.5 kHz sine wave signal

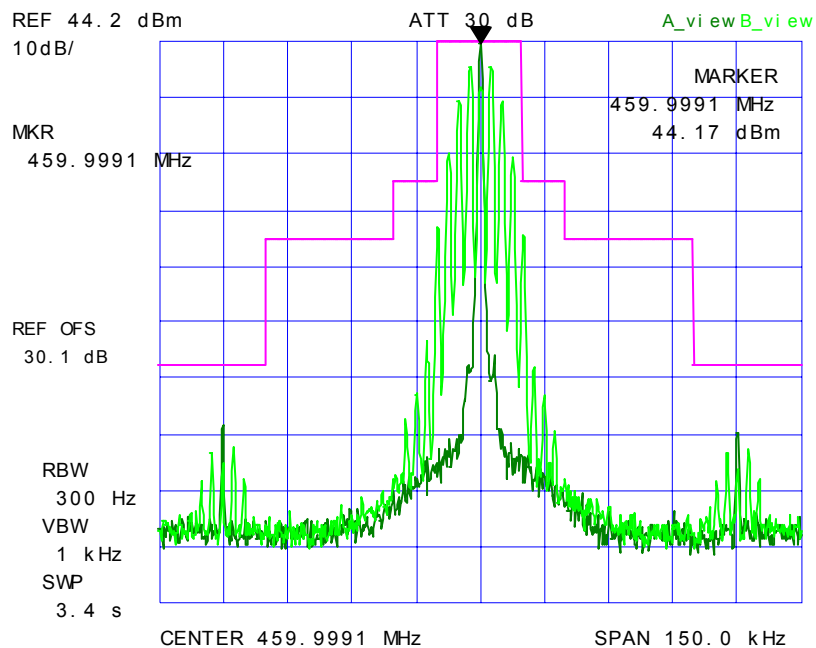

PLOT # 164 Emission Mask B
Frequency: 460 MHz, Low Power, 25 kHz Channel Spacing
Modulation: FM modulation with 2.5 kHz sine wave signal

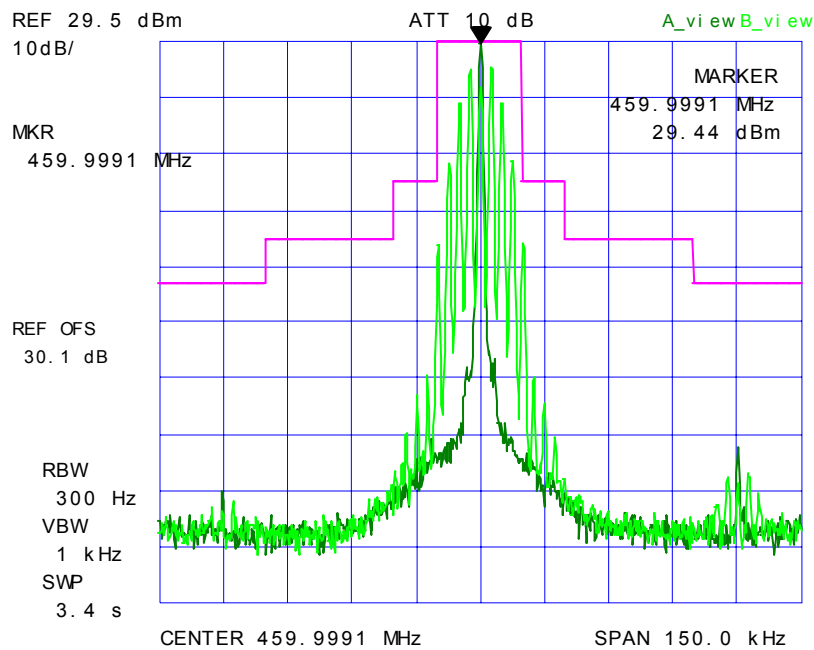

PLOT # 165 Emission Mask B
Frequency: 470 MHz, High Power, 25 kHz Channel Spacing
Modulation: FM modulation with 2.5 kHz sine wave signal

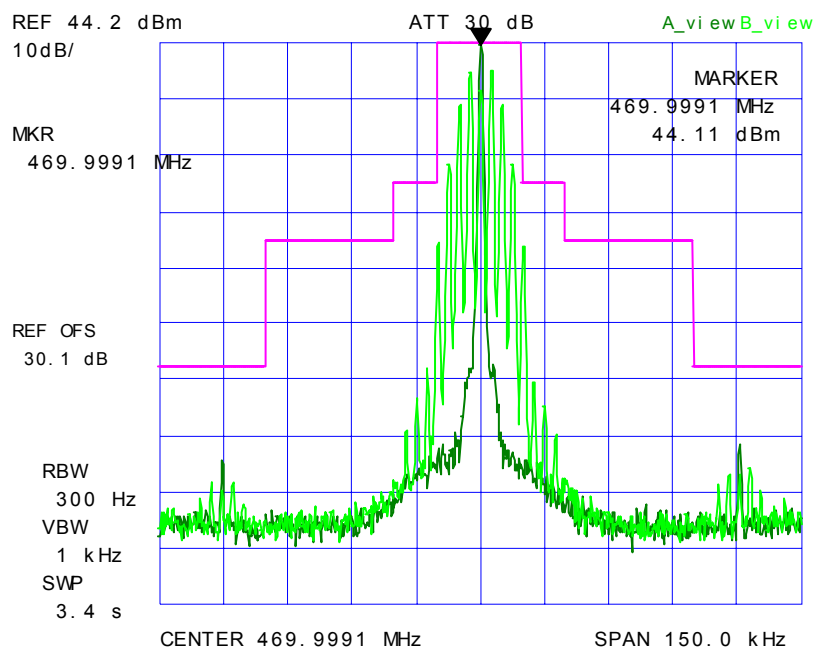

PLOT # 166 Emission Mask B
Frequency: 470 MHz, Low Power, 25 kHz Channel Spacing
Modulation: FM modulation with 2.5 kHz sine wave signal

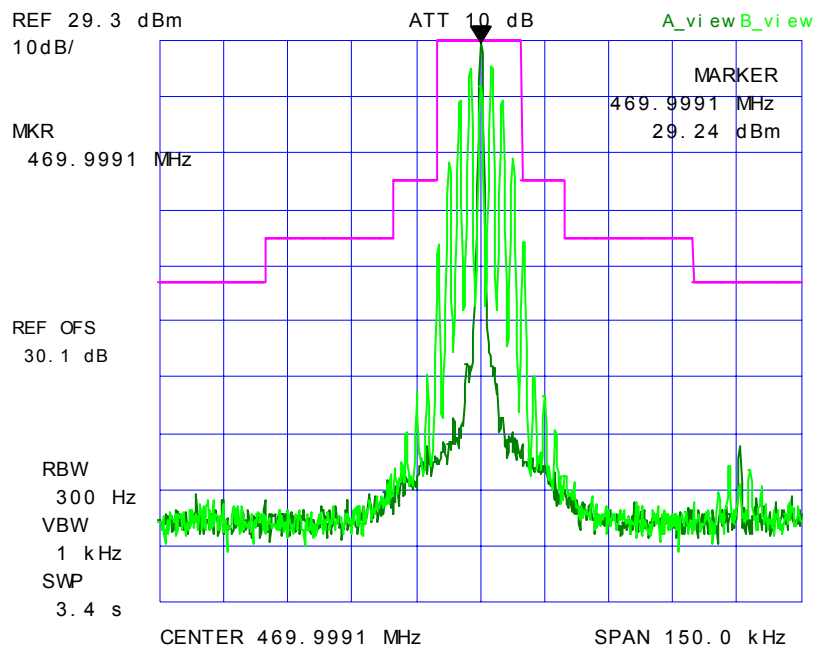

PLOT # 167 Emission Mask C
Frequency: 450 MHz, High Power, 25 kHz Channel Spacing
Modulation: Digital

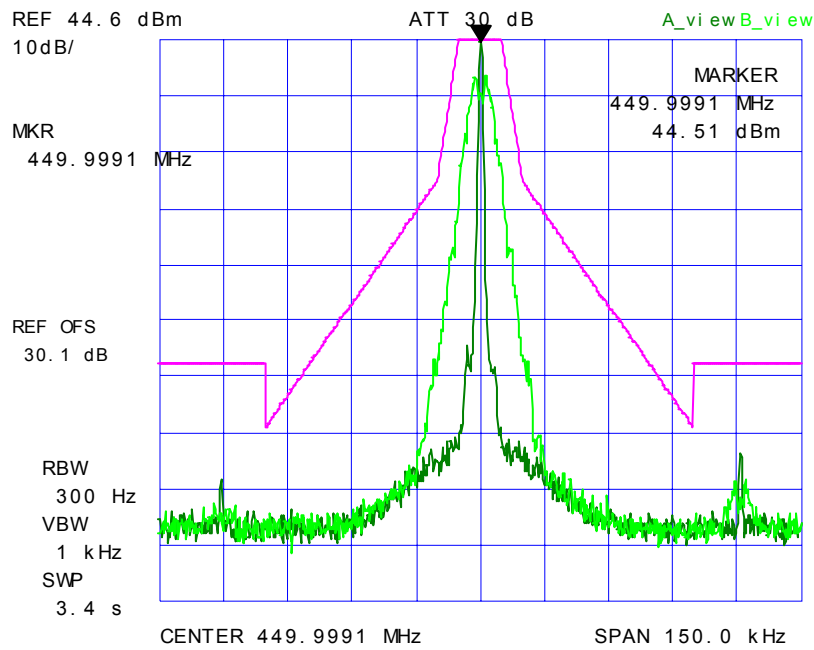

PLOT # 168 Emission Mask C
Frequency: 450 MHz, Low Power, 25 kHz Channel Spacing
Modulation: Digital

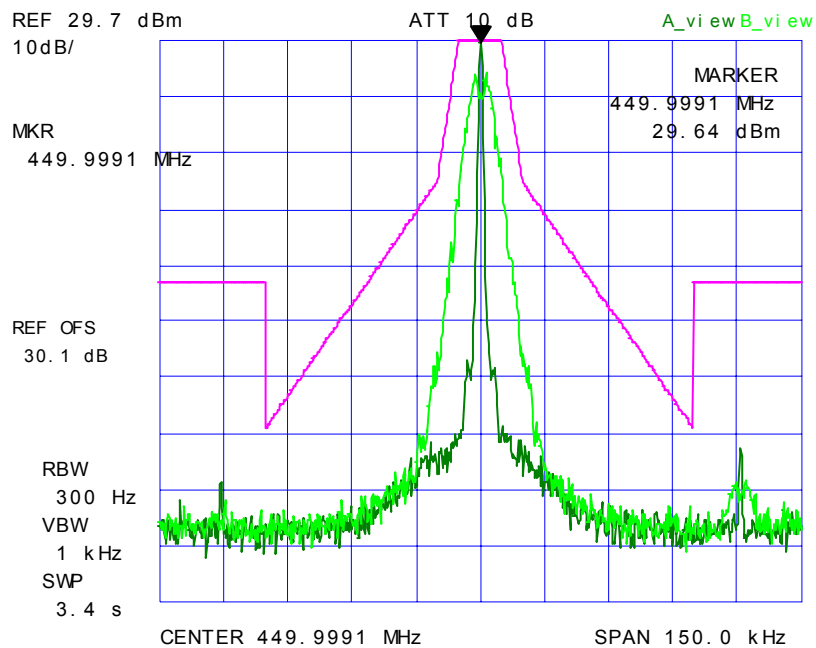

PLOT # 169 Emission Mask C
Frequency: 460 MHz, High Power, 25 kHz Channel Spacing
Modulation: Digital

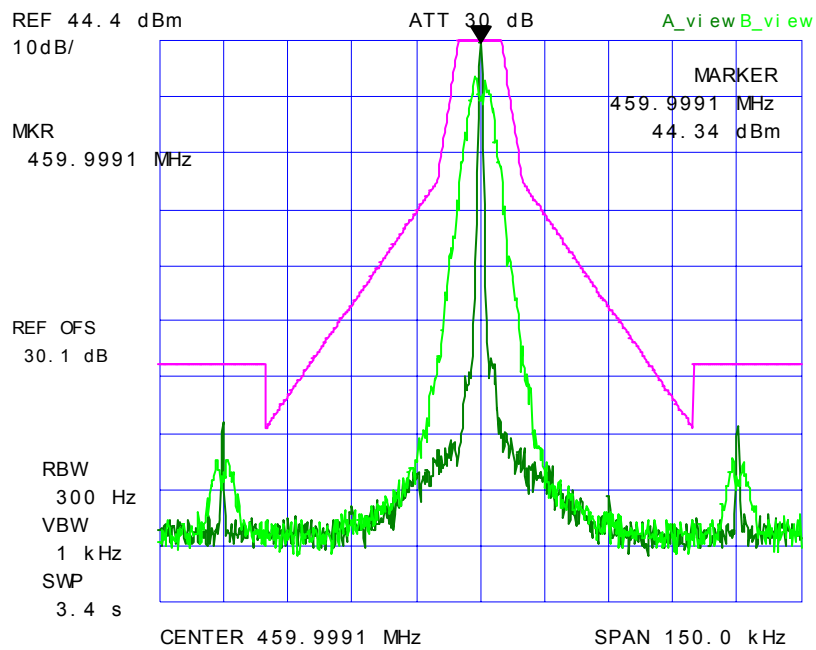

PLOT # 170 Emission Mask C
Frequency: 460 MHz, Low Power, 25 kHz Channel Spacing
Modulation: Digital

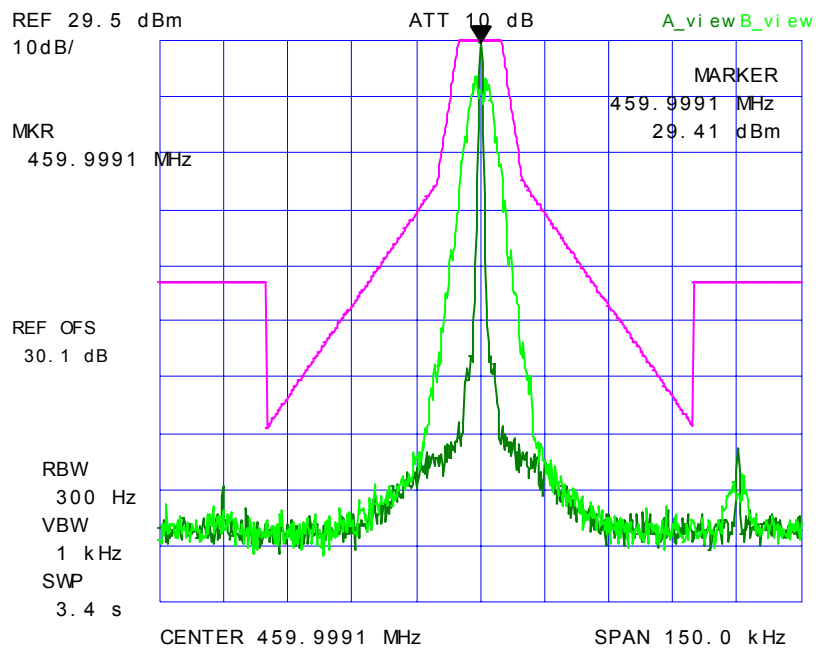

PLOT # 171 Emission Mask C
Frequency: 470 MHz, High Power, 25 kHz Channel Spacing
Modulation: Digital

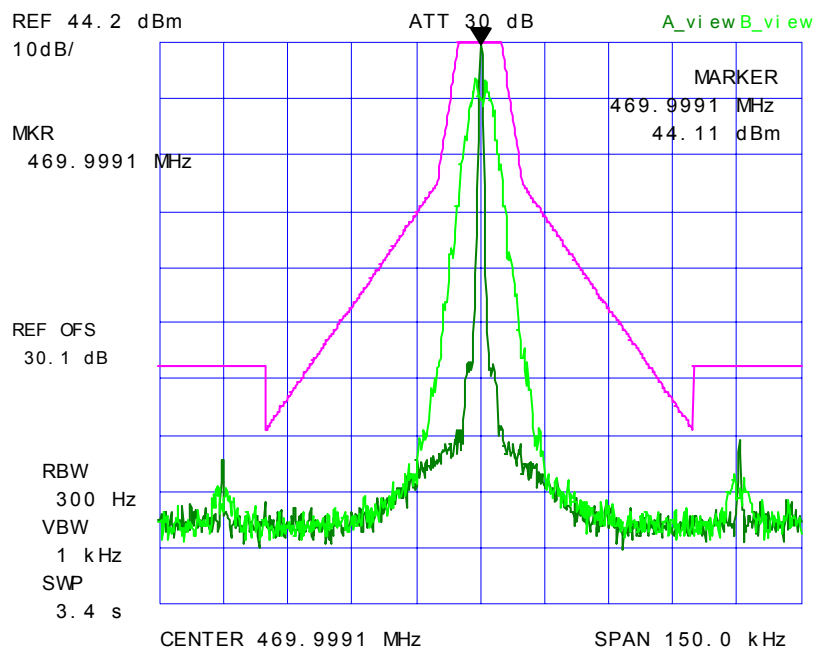

PLOT # 172 Emission Mask C
Frequency: 470 MHz, Low Power, 25 kHz Channel Spacing
Modulation: Digital

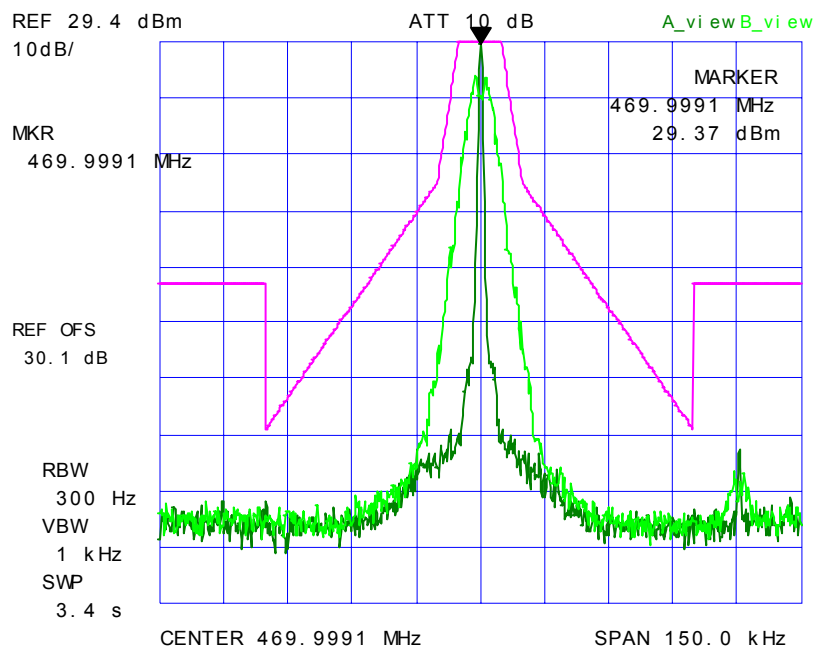

PLOT # 173 Emission Mask D
Frequency: 450 MHz, High Power, 12.5 kHz Channel Spacing
Modulation: FM modulation with 2.5 kHz sine wave signal

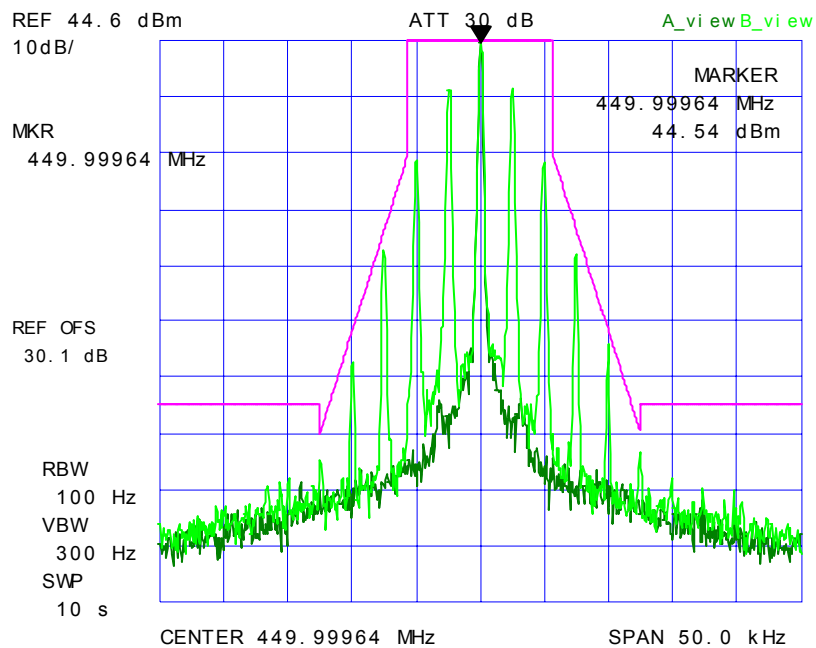

PLOT # 174 Emission Mask D
Frequency: 450 MHz, Low Power, 12.5 kHz Channel Spacing
Modulation: FM modulation with 2.5 kHz sine wave signal

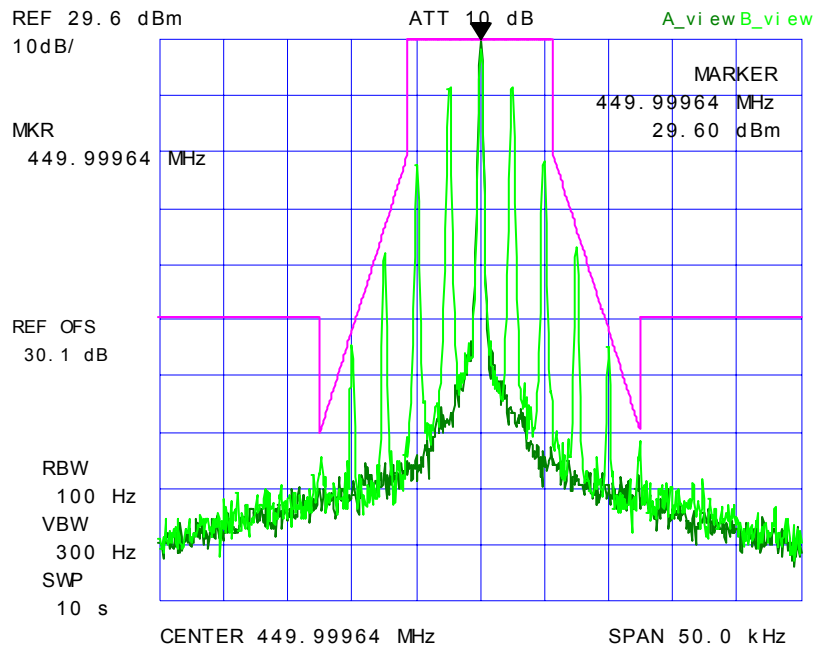

PLOT # 175 Emission Mask D
Frequency: 460 MHz, High Power, 12.5 kHz Channel Spacing
Modulation: FM modulation with 2.5 kHz sine wave signal

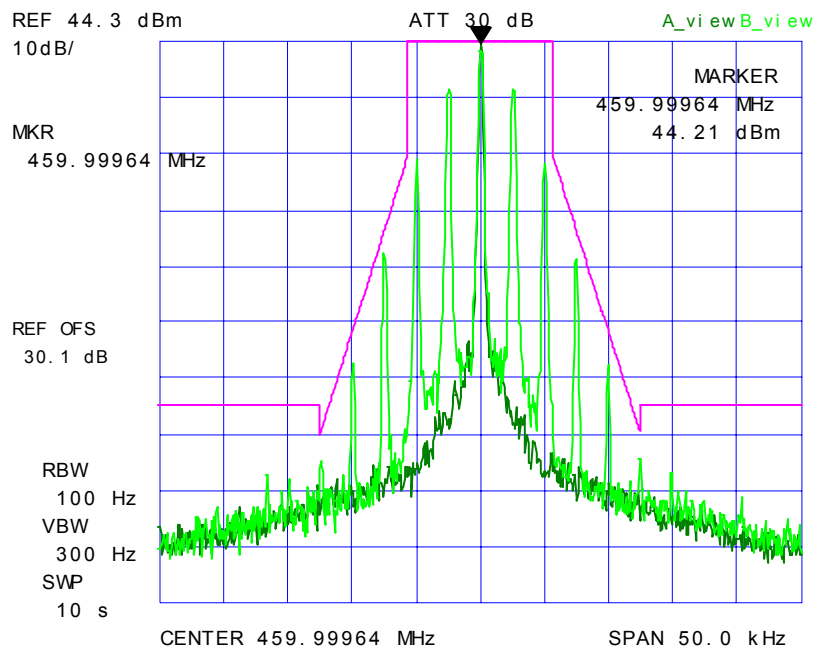

PLOT # 176 Emission Mask D
Frequency: 460 MHz, Low Power, 12.5 kHz Channel Spacing
Modulation: FM modulation with 2.5 kHz sine wave signal

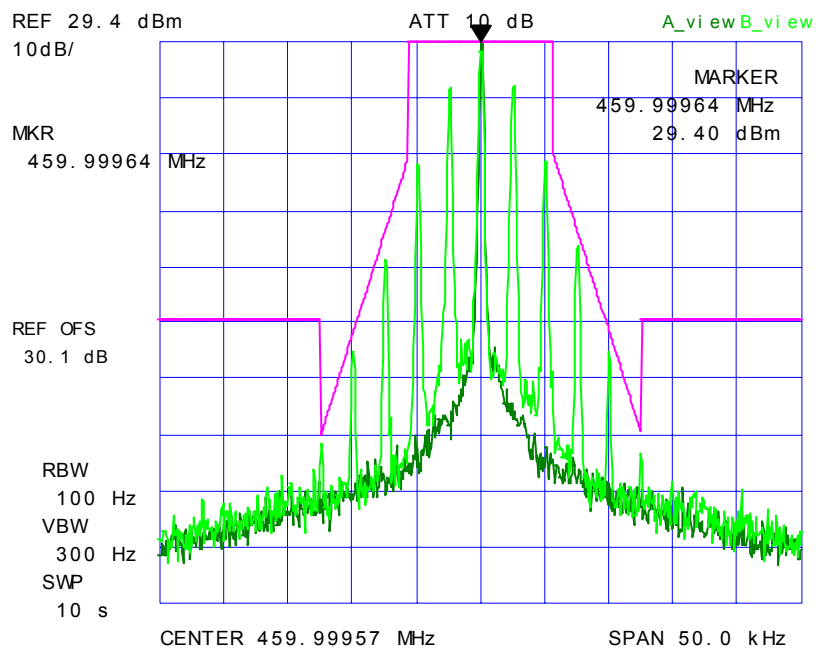

PLOT # 177 Emission Mask D
Frequency: 470 MHz, High Power, 12.5 kHz Channel Spacing
Modulation: FM modulation with 2.5 kHz sine wave signal

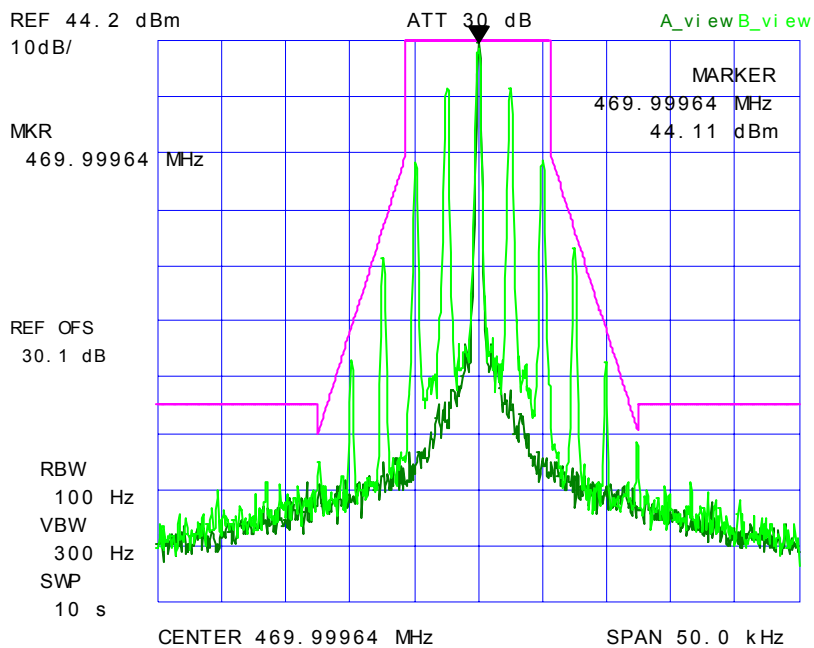

PLOT # 178 Emission Mask D
Frequency: 470 MHz, Low Power, 12.5 kHz Channel Spacing
Modulation: FM modulation with 2.5 kHz sine wave signal

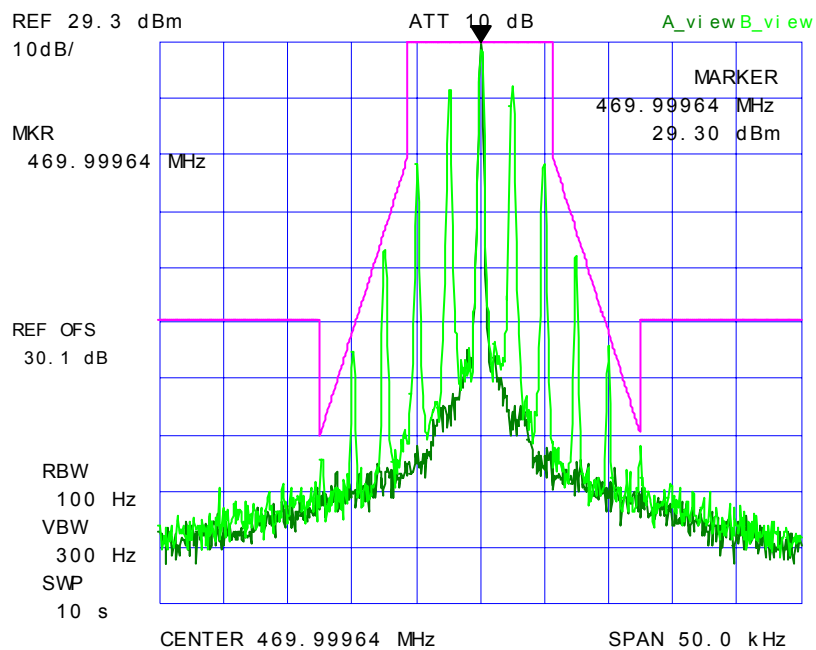

PLOT # 179 Emission Mask D
Frequency: 450 MHz, High Power, 12.5 kHz Channel Spacing
Modulation: Digital

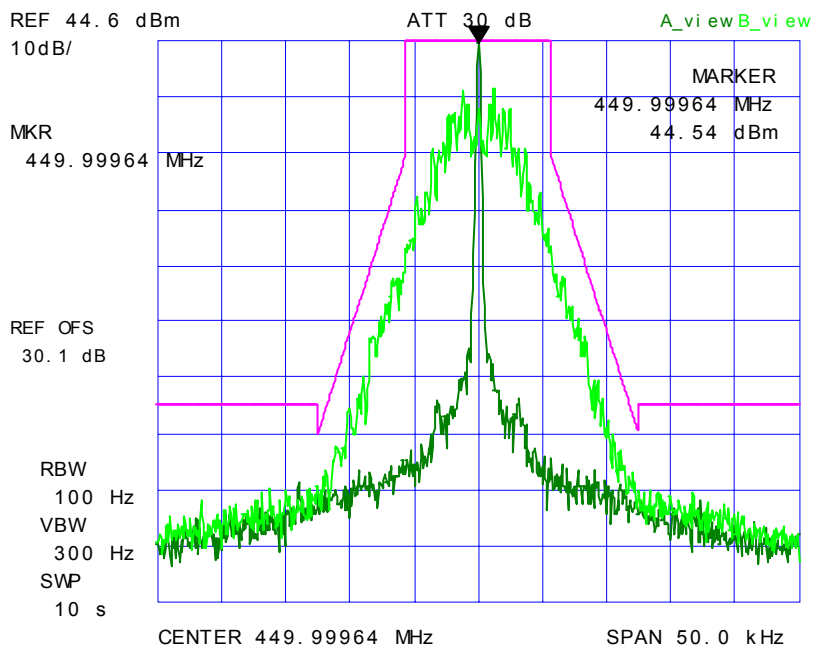

PLOT # 180 Emission Mask D
Frequency: 450 MHz, Low Power, 12.5 kHz Channel Spacing
Modulation: Digital

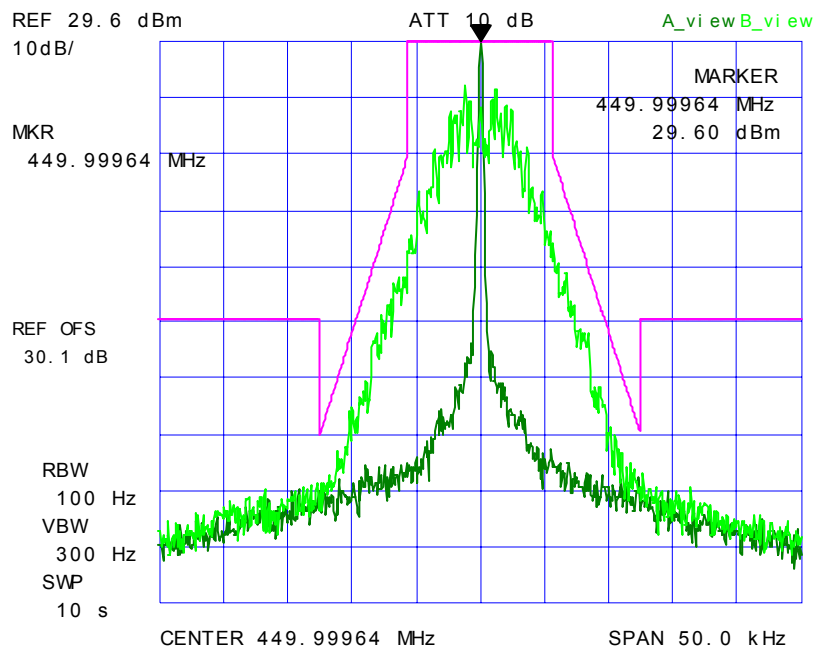

PLOT # 181 Emission Mask D
Frequency: 460 MHz, High Power, 12.5 kHz Channel Spacing
Modulation: Digital

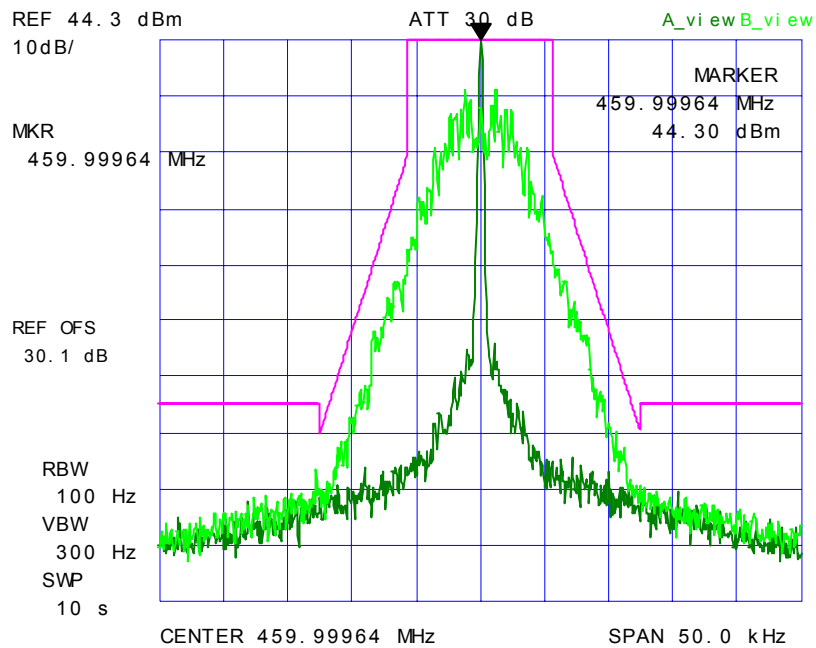

PLOT # 182 Emission Mask D
Frequency: 460 MHz, Low Power, 12.5 kHz Channel Spacing
Modulation: Digital

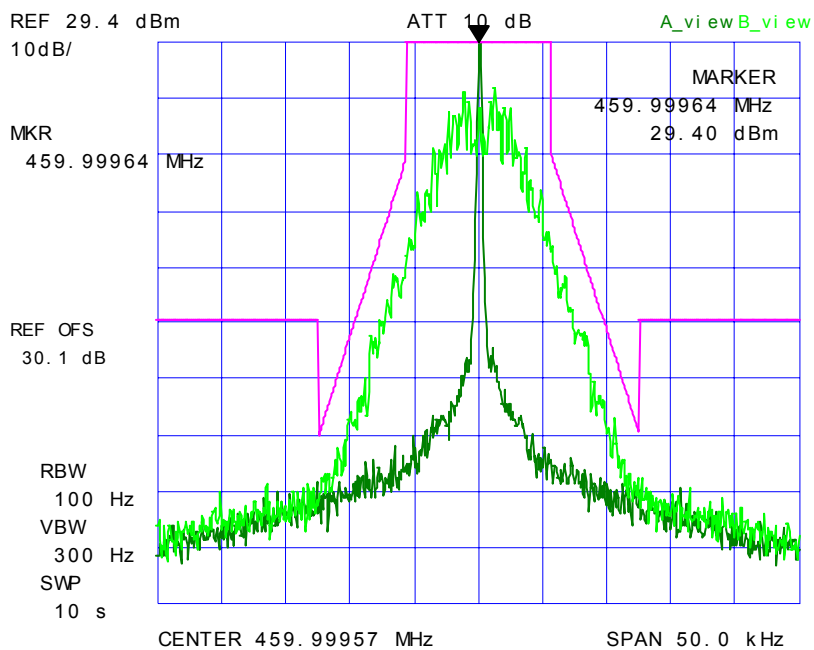

PLOT # 183 Emission Mask D
Frequency: 470 MHz, High Power, 12.5 kHz Channel Spacing
Modulation: Digital

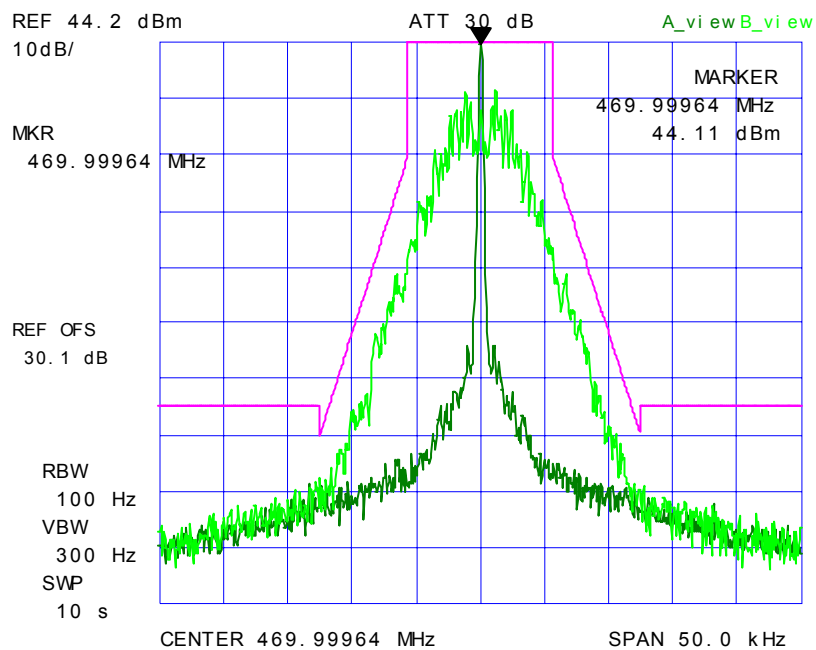

PLOT # 184 Emission Mask D
Frequency: 470 MHz, Low Power, 12.5 kHz Channel Spacing
Modulation: Digital

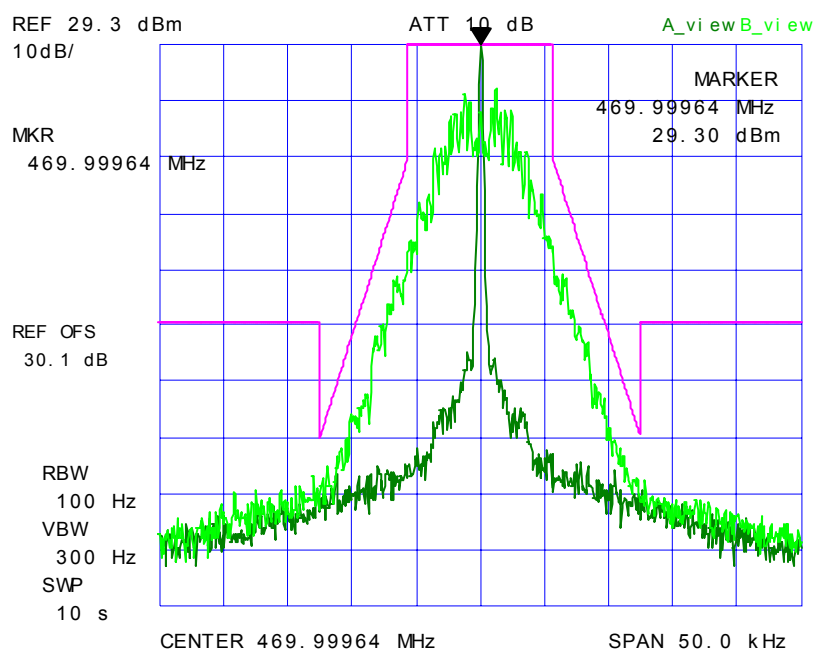

PLOT # 185 Emission Mask B
Frequency: 470 MHz, High Power, 25 kHz Channel Spacing
Modulation: FM modulation with 2.5 kHz sine wave signal

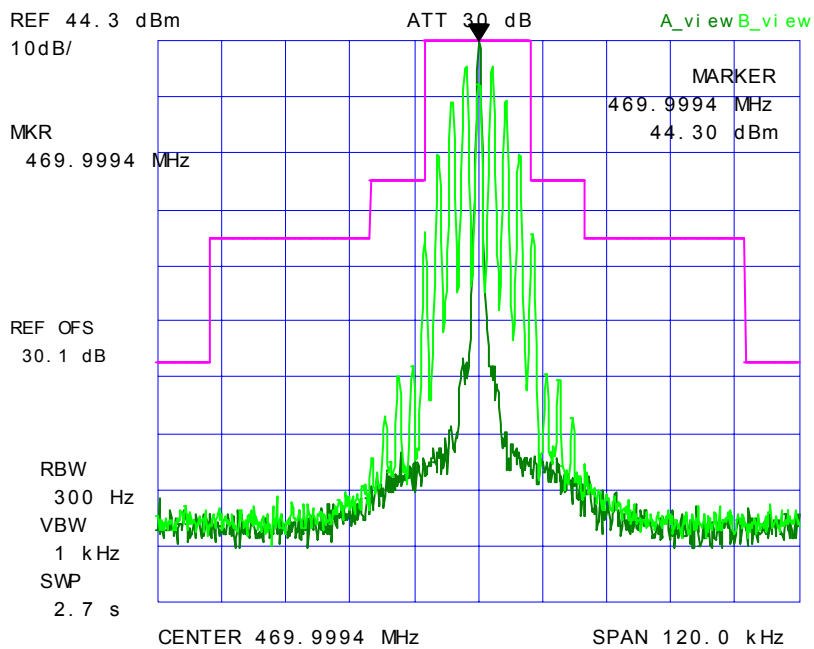

PLOT # 186 Emission Mask B
Frequency: 470 MHz, Low Power, 25 kHz Channel Spacing
Modulation: FM modulation with 2.5 kHz sine wave signal

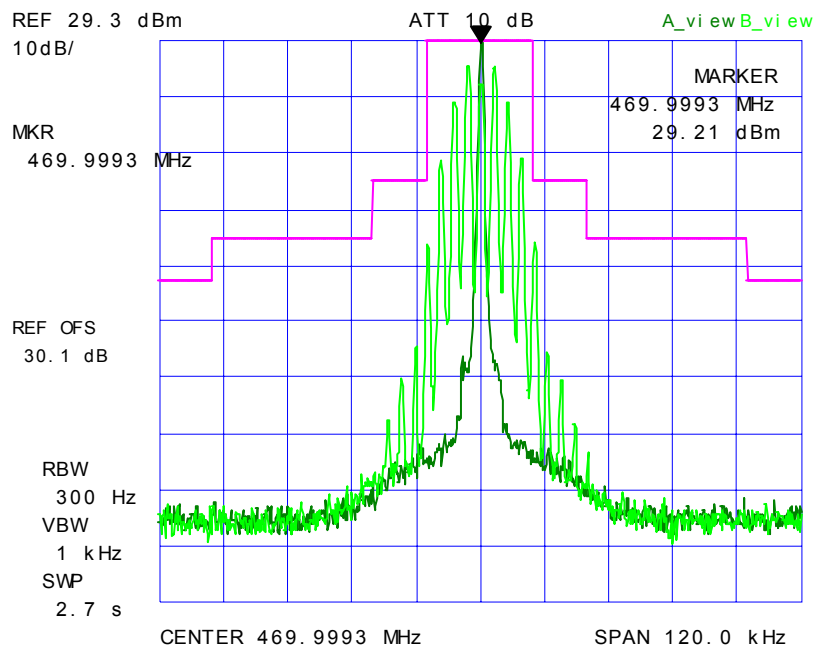

PLOT # 187 Emission Mask B
Frequency: 491 MHz, High Power, 25 kHz Channel Spacing
Modulation: FM modulation with 2.5 kHz sine wave signal

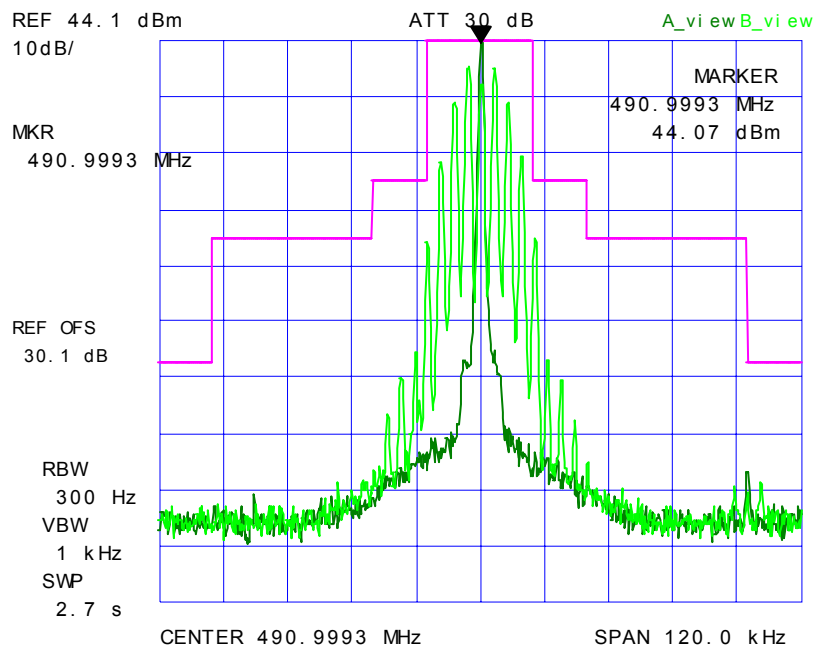

PLOT # 188 Emission Mask B
Frequency: 491 MHz, Low Power, 25 kHz Channel Spacing
Modulation: FM modulation with 2.5 kHz sine wave signal

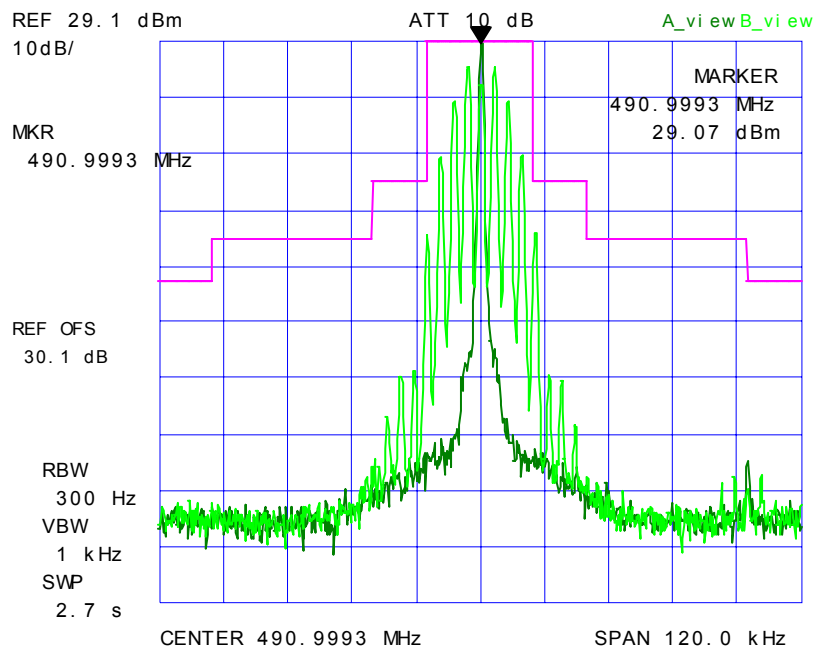

PLOT # 189 Emission Mask B
Frequency: 512 MHz, High Power, 25 kHz Channel Spacing
Modulation: FM modulation with 2.5 kHz sine wave signal

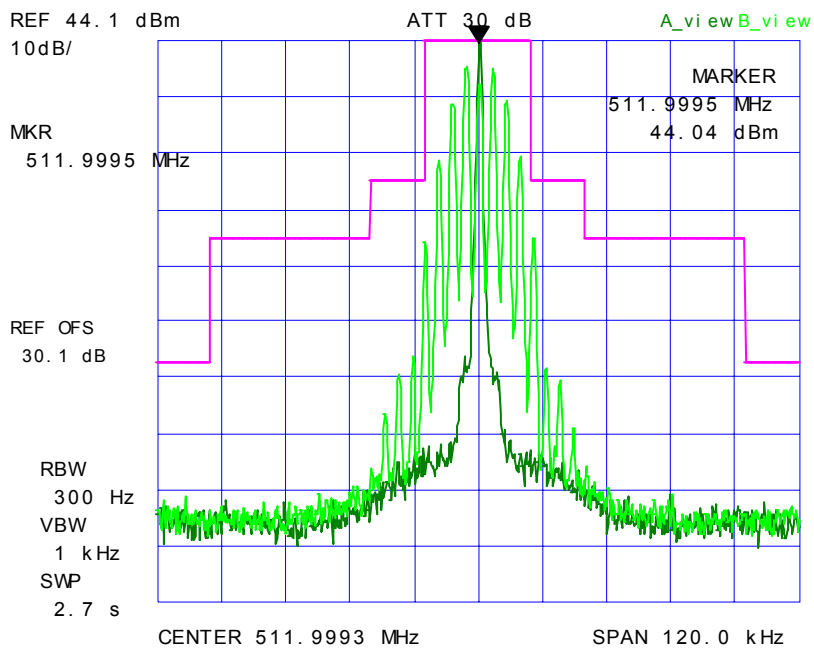

PLOT # 190 Emission Mask B
Frequency: 512 MHz, Low Power, 25 kHz Channel Spacing
Modulation: FM modulation with 2.5 kHz sine wave signal

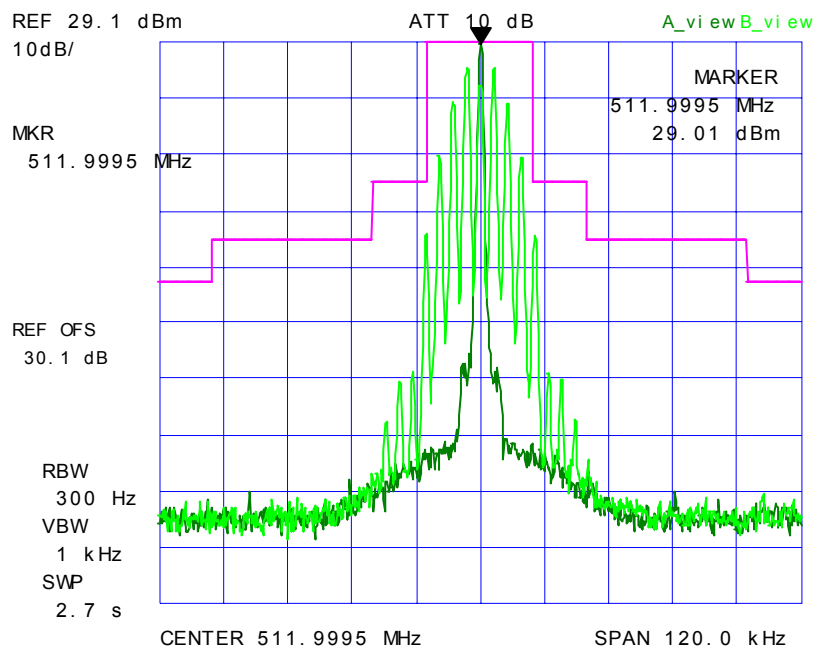

PLOT # 191 Emission Mask C
Frequency: 470 MHz, High Power, 25 kHz Channel Spacing
Modulation: Digital

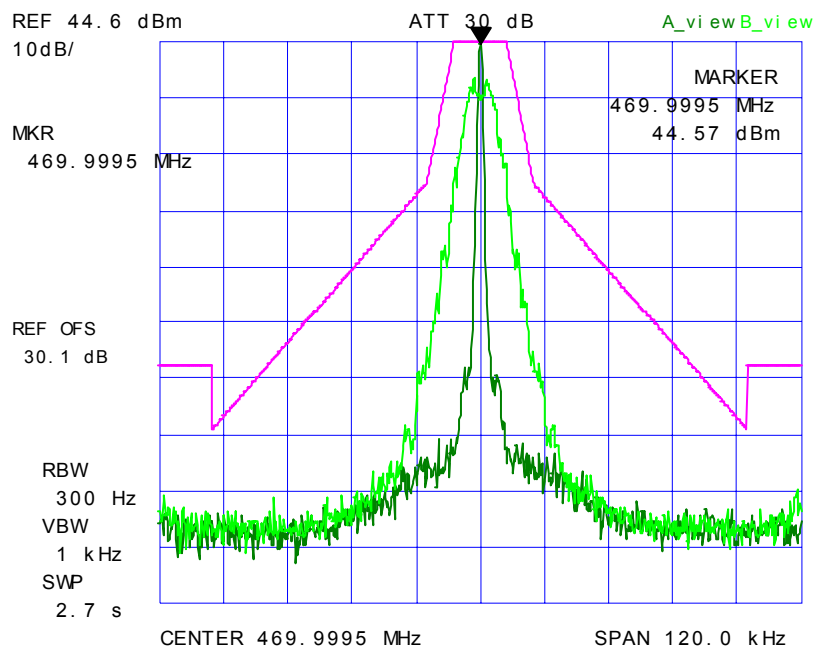

PLOT # 192 Emission Mask C
Frequency: 470 MHz, Low Power, 25 kHz Channel Spacing
Modulation: Digital

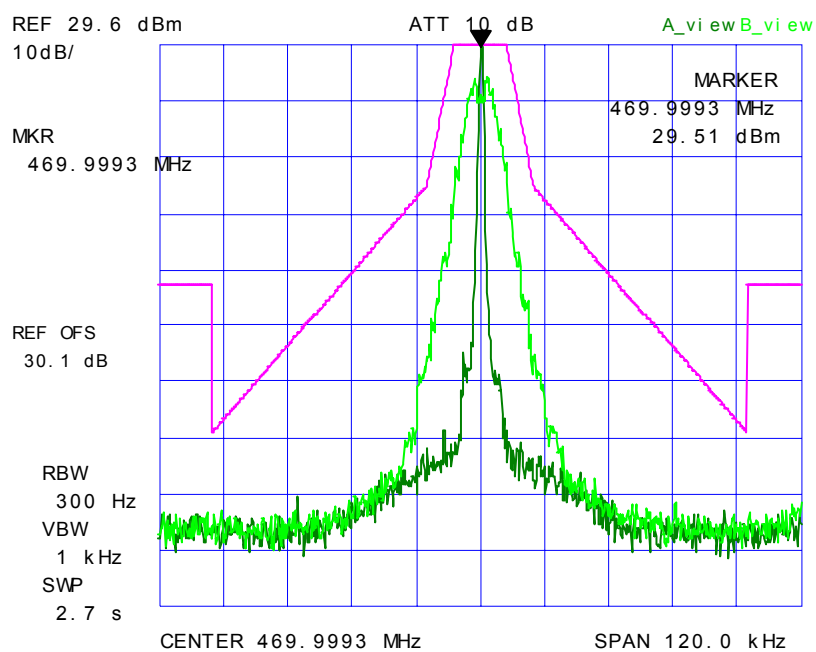

PLOT # 193 Emission Mask C
Frequency: 491 MHz, High Power, 25 kHz Channel Spacing
Modulation: Digital

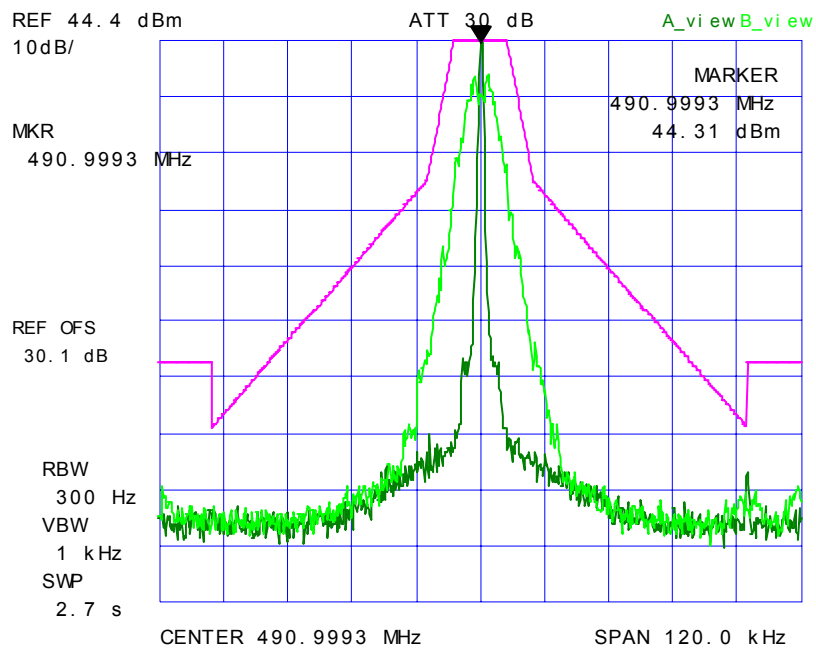

PLOT # 194 Emission Mask C
Frequency: 491 MHz, Low Power, 25 kHz Channel Spacing
Modulation: Digital

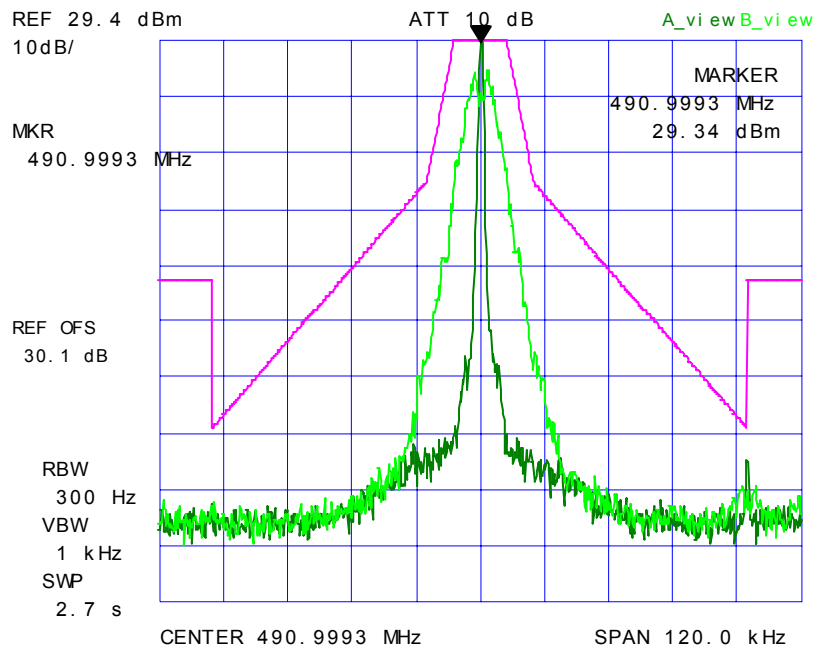

PLOT # 195 Emission Mask C
Frequency: 512 MHz, High Power, 25 kHz Channel Spacing
Modulation: Digital

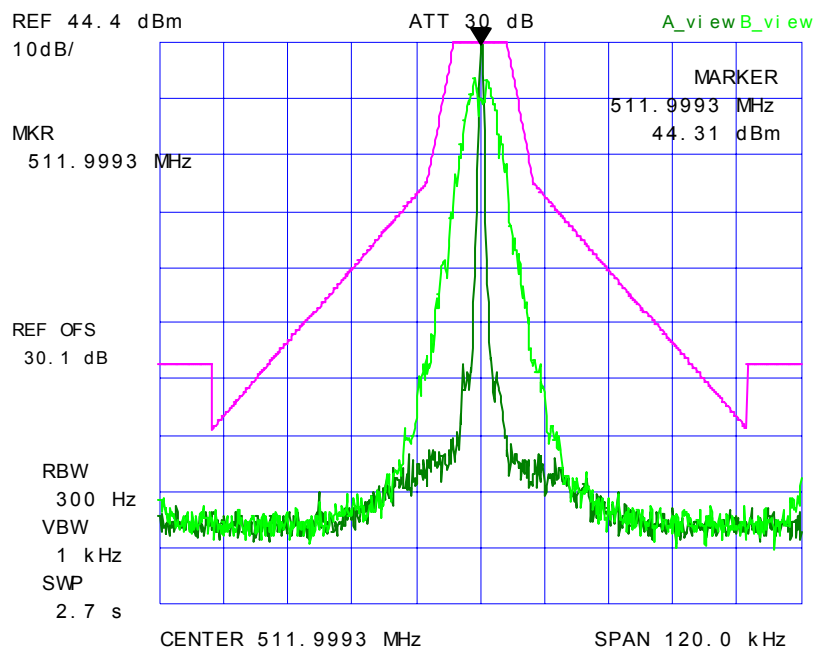

PLOT # 196 Emission Mask C
Frequency: 512 MHz, Low Power, 25 kHz Channel Spacing
Modulation: Digital

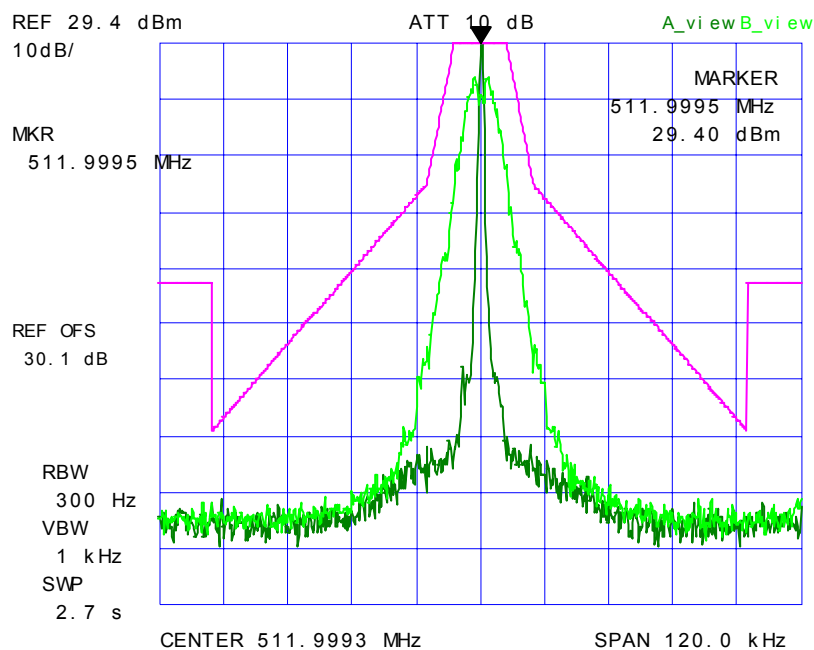

PLOT # 197 Emission Mask D
Frequency: 470 MHz, High Power, 12.5 kHz Channel Spacing
Modulation: FM modulation with 2.5 kHz sine wave signal

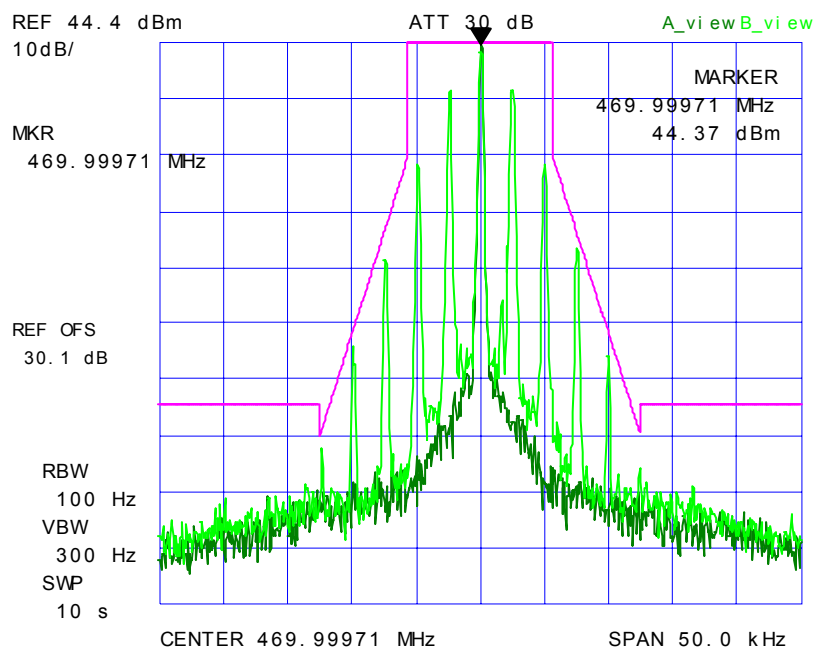

PLOT # 198 Emission Mask D
Frequency: 470 MHz, Low Power, 12.5 kHz Channel Spacing
Modulation: FM modulation with 2.5 kHz sine wave signal

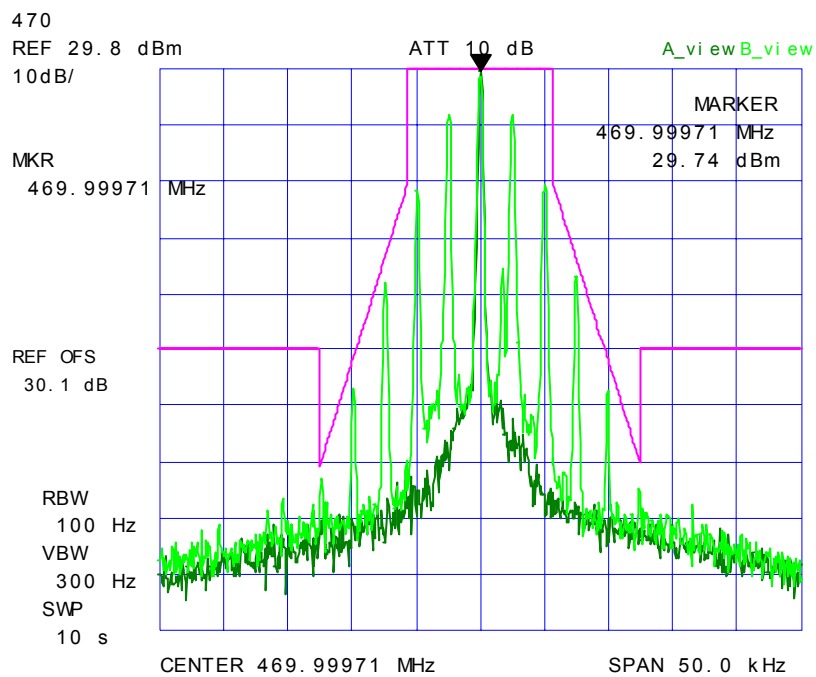

PLOT # 199 Emission Mask D
Frequency: 491 MHz, High Power, 12.5 kHz Channel Spacing
Modulation: FM modulation with 2.5 kHz sine wave signal

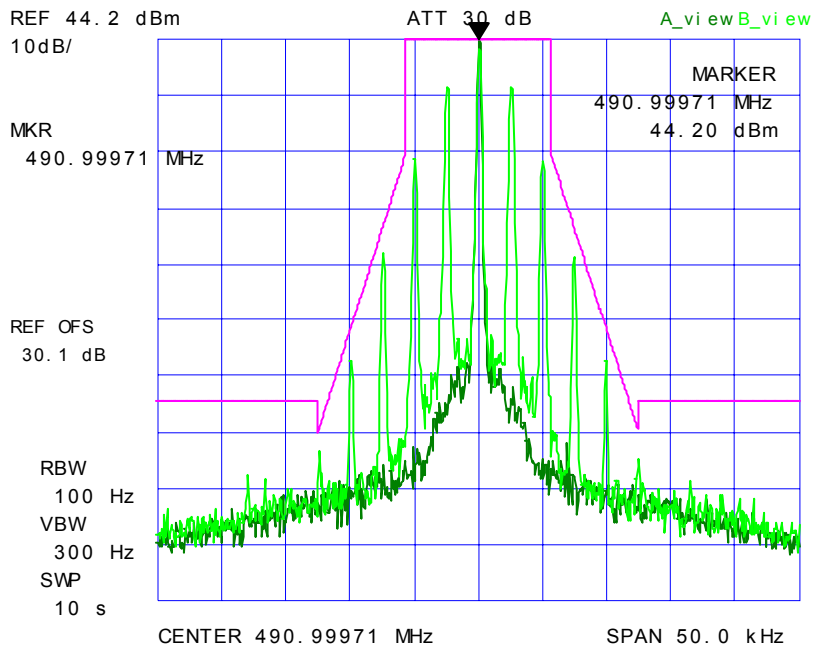

PLOT # 200 Emission Mask D
Frequency: 491 MHz, Low Power, 12.5 kHz Channel Spacing
Modulation: FM modulation with 2.5 kHz sine wave signal

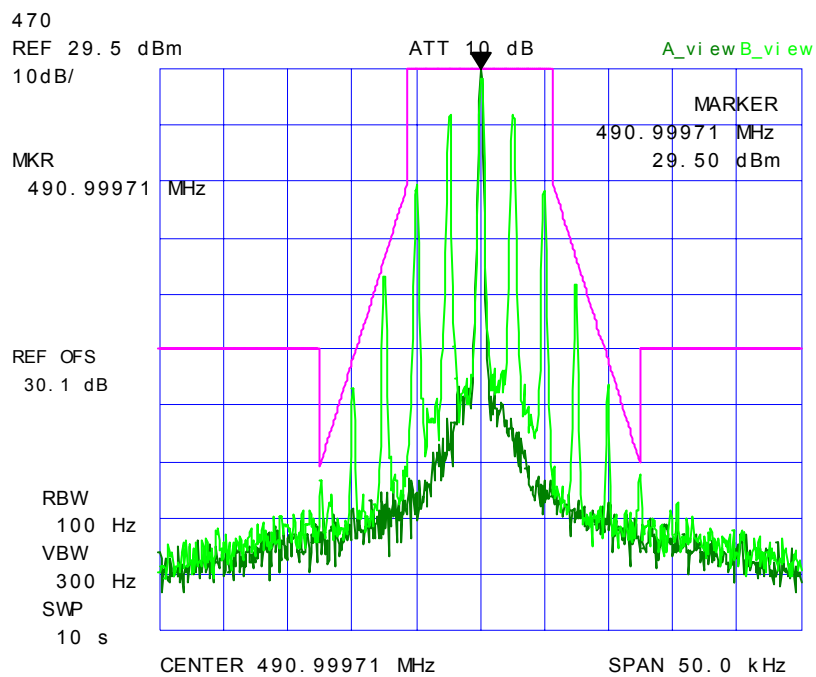

PLOT # 201 Emission Mask D
Frequency: 512 MHz, High Power, 12.5 kHz Channel Spacing
Modulation: FM modulation with 2.5 kHz sine wave signal

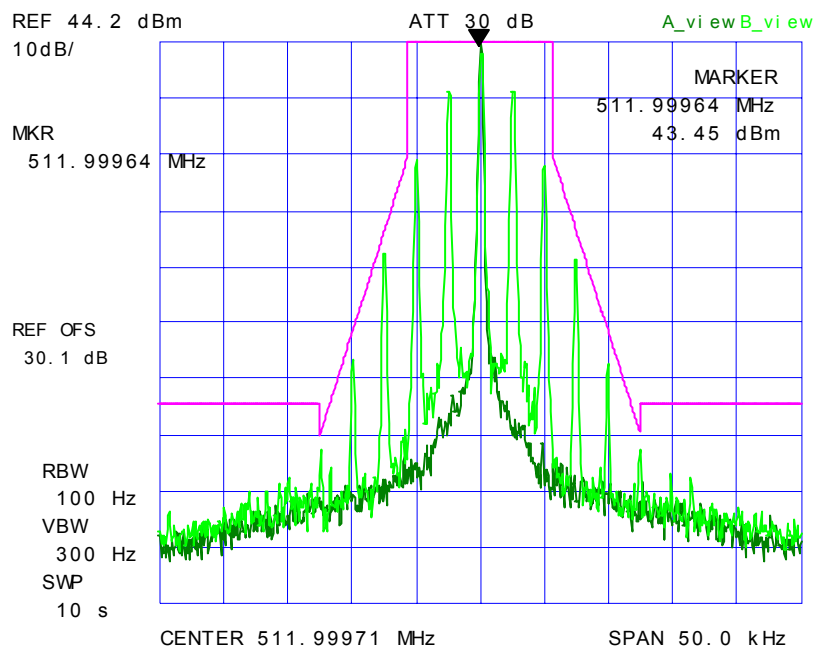

PLOT # 202 Emission Mask D
Frequency: 512 MHz, Low Power, 12.5 kHz Channel Spacing
Modulation: FM modulation with 2.5 kHz sine wave signal

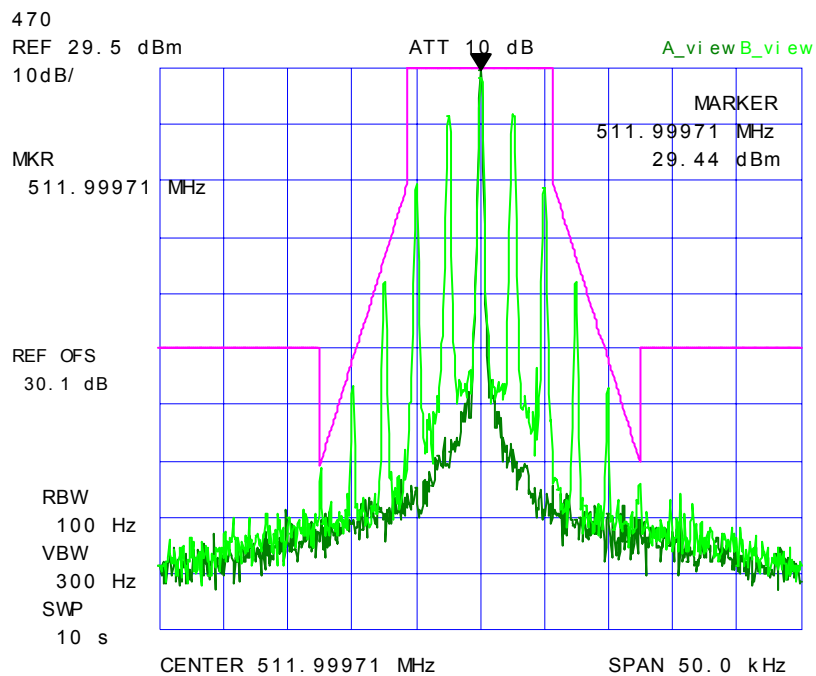

PLOT # 203 Emission Mask D
Frequency: 470 MHz, High Power, 12.5 kHz Channel Spacing
Modulation: Digital

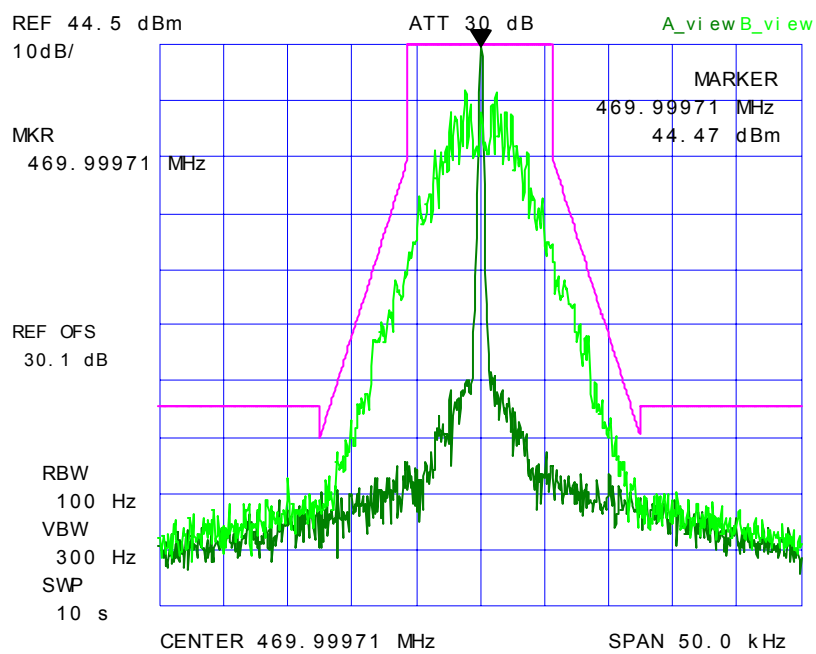

PLOT # 204 Emission Mask D
Frequency: 470 MHz, Low Power, 12.5 kHz Channel Spacing
Modulation: Digital

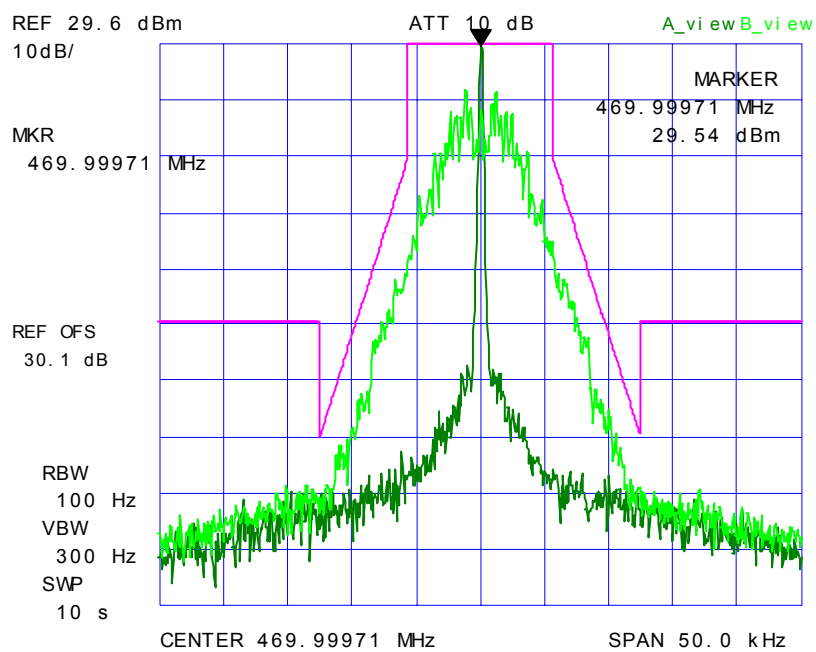

PLOT # 205 Emission Mask D
Frequency: 491 MHz, High Power, 12.5 kHz Channel Spacing
Modulation: Digital

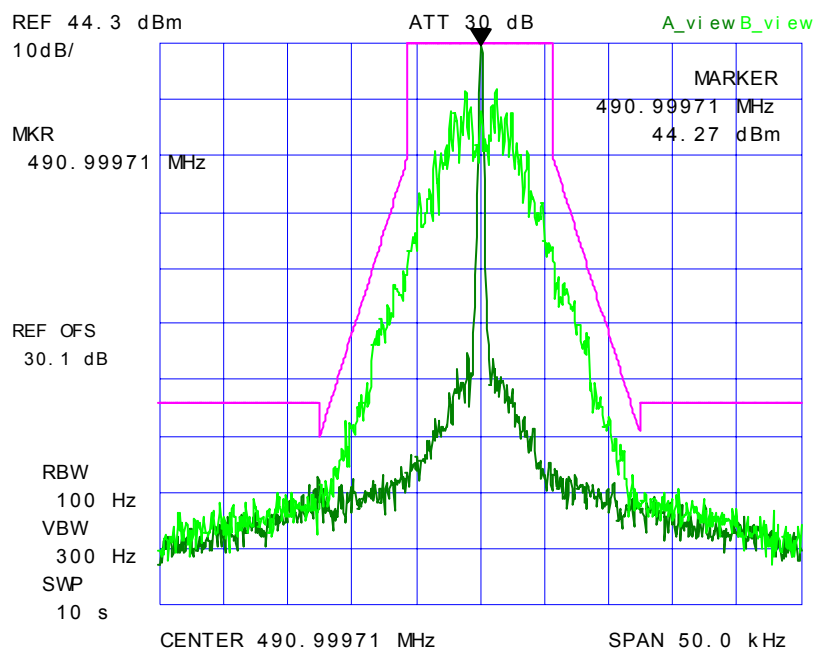

PLOT # 206 Emission Mask D
Frequency: 491 MHz, Low Power, 12.5 kHz Channel Spacing
Modulation: Digital

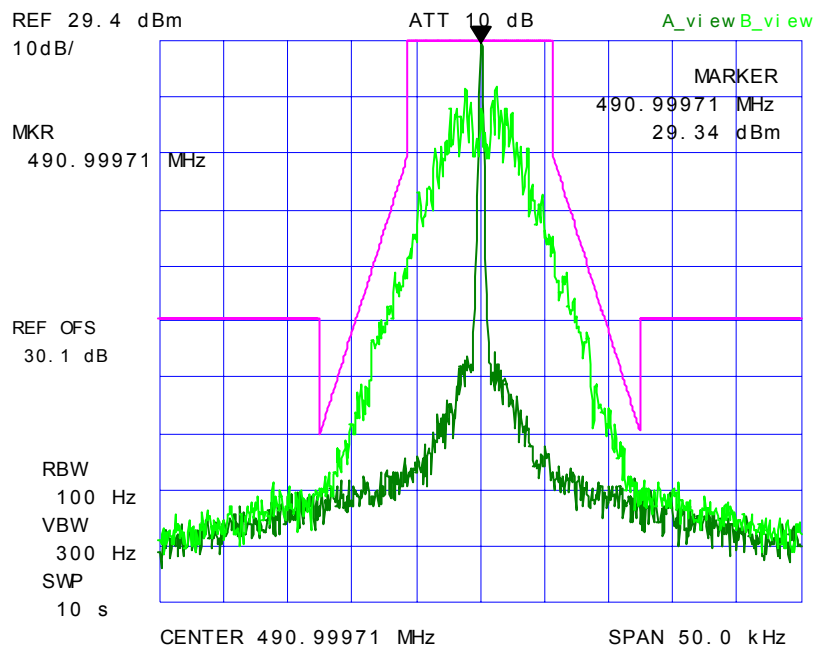

PLOT # 207 Emission Mask D
Frequency: 512 MHz, High Power, 12.5 kHz Channel Spacing
Modulation: Digital

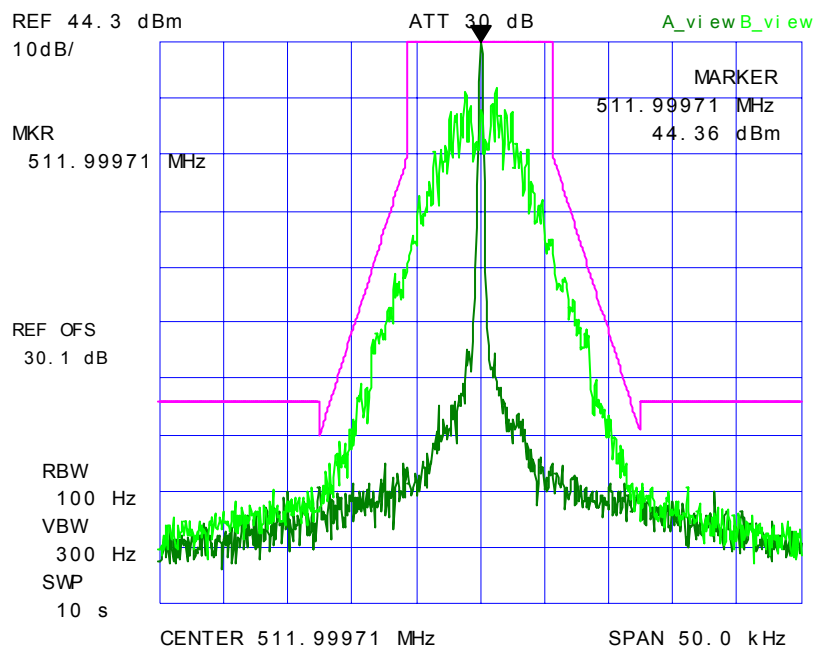

PLOT # 208 Emission Mask D
Frequency: 512 MHz, Low Power, 12.5 kHz Channel Spacing
Modulation: Digital

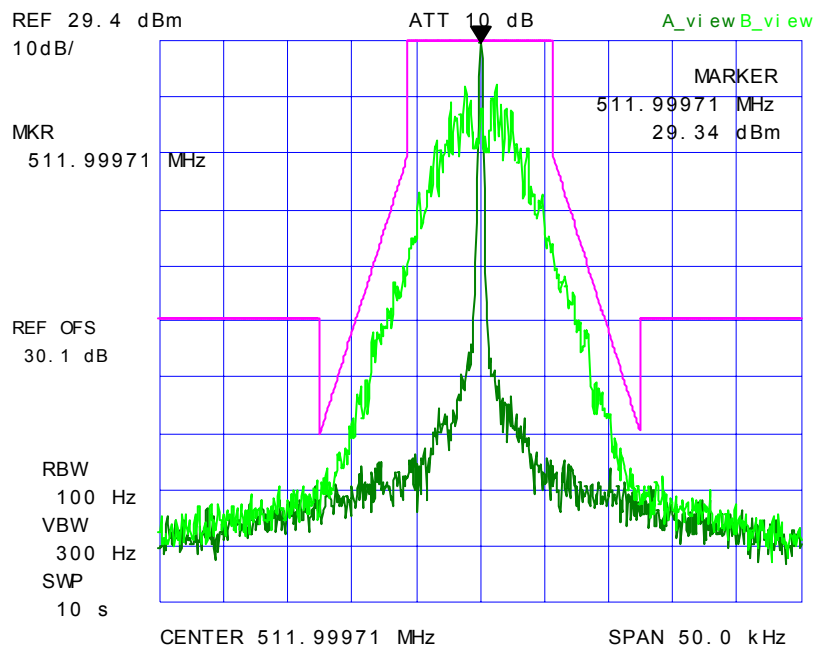

5.11. TRANSMITTER ANTENNA POWER SPURIOUS/HARMONIC CONDUCTED EMISSIONS [§§ 2.1051, 90.209 & 90.210]

5.11.1. Limits

Emissions shall be attenuated below the mean output power of the transmitter as follows:

FCC Rules	Frequency Range	Attenuation Limit (dBc)
90.210(b)	10 MHz to Lowest frequency of the radio to 10 th harmonic of the highest frequency of the radio	43+10*log(P) or -13 dBm
90.210(d)	10 MHz to Lowest frequency of the radio to 10 th harmonic of the highest frequency of the radio	50+10*log(P) or -20 dBm or 70 dBc whichever is less

5.11.2. Method of Measurements

Refer to Exhibit 7 of this report for measurement details

5.11.3. Test Equipment List

Test Instruments	Manufacturer	Model No.	Serial No.	Frequency Range
Function Generator	Stanford Research Systems	DS345	34591	1 μHz – 30.2 MHz
Digital Voltmeter	Hewlett-Packard	3456A	2015A04523	DC-250 KHz
Spectrum Analyzer	Rhode & Schwarz	FSEK20/B4/B21	834157/005	9 kHz- 40 GHz
Attenuator	Weinschel Corp	48-30-34	BM5354	DC-18 GHz
Digital Multimeter	Tenma	72-6202	20UHF27	DC-100 kHz
Power Supply	Tenma	72-6153	--	DC 0-20 V, 0-10A.
High Pass Filter	Mini-Circuits	SHP-UHF	10425	Cut-off Frequency at 750 MHz

5.11.4. Test Arrangement

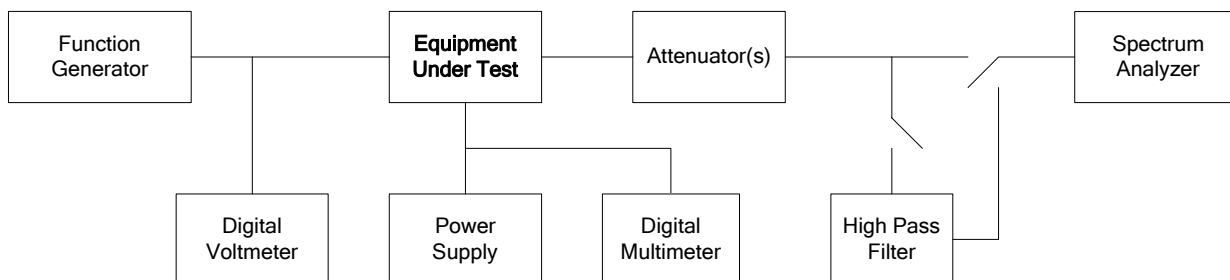

Remarks:

- There was no difference in spurious/harmonic emissions on pre-scans for all different modulations and also for narrow band operation and wide band operation. Therefore, the rf spurious/harmonic emissions in this section would be performed without modulation for 12.5 kHz Channel Spacing and the more stringent limit of $50 + 10 \cdot \log(P)$ would be applied for worst case.
- The emissions were scanned from 10 MHz to 5 GHz.

**PLOT # 209 Transmitter Conducted Spurious Emissions, High Power
Fc: 380 MHz**

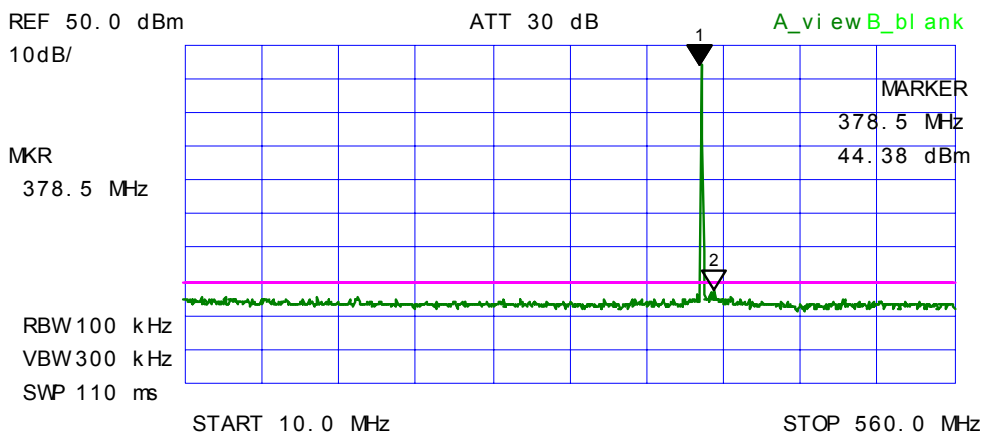

*** Multi Marker List ***

No. 1:	378.5 MHz	44.38 dBm	A
No. 2:	387.9 MHz	-22.50 dBm	A
No. 3:			
No. 4:			
No. 5:			
No. 6:			
No. 7:			
No. 8:			
Δ:			

**PLOT # 210 Transmitter Conducted Spurious Emissions, High Power
Fc: 380 MHz**

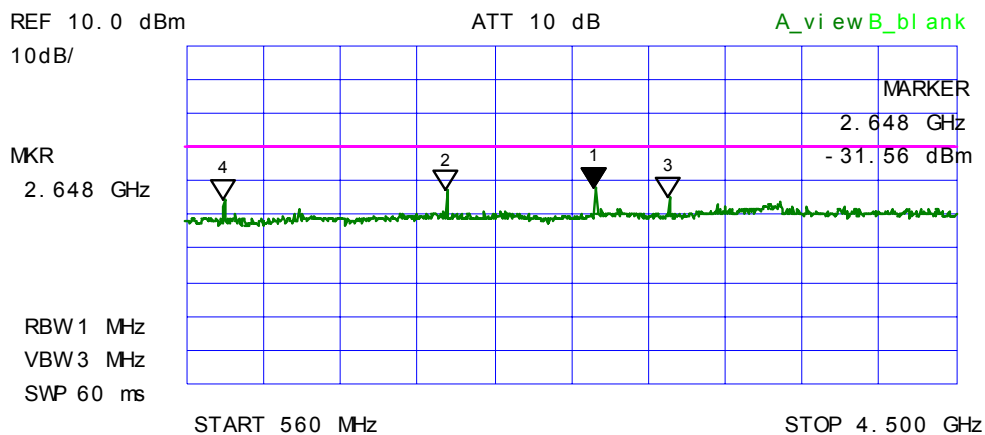

*** Multi Marker List ***

No. 1:	2.648 GHz	-31.56 dBm	A
No. 2:	1.888 GHz	-32.63 dBm	A
No. 3:	3.025 GHz	-34.44 dBm	A
No. 4:	751 MHz	-35.47 dBm	A
No. 5:			
No. 6:			
No. 7:			
No. 8:			
:			

**PLOT # 211 Transmitter Conducted Spurious Emissions, Low Power
Fc: 380 MHz**

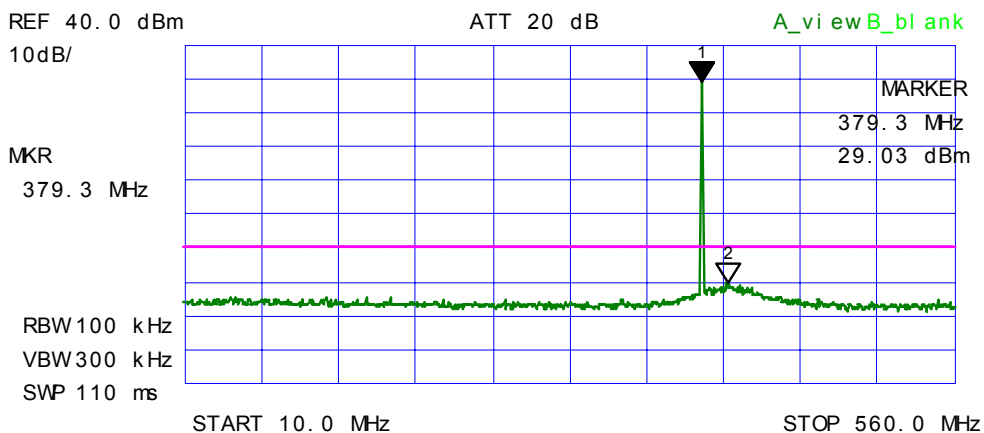

*** Multi Marker List ***

No. 1:	379.3 MHz	29.03 dBm	A
No. 2:	398.1 MHz	-30.06 dBm	A
No. 3:			
No. 4:			
No. 5:			
No. 6:			
No. 7:			
No. 8:			

**PLOT # 212 Transmitter Conducted Spurious Emissions, Low Power
Fc: 380 MHz**

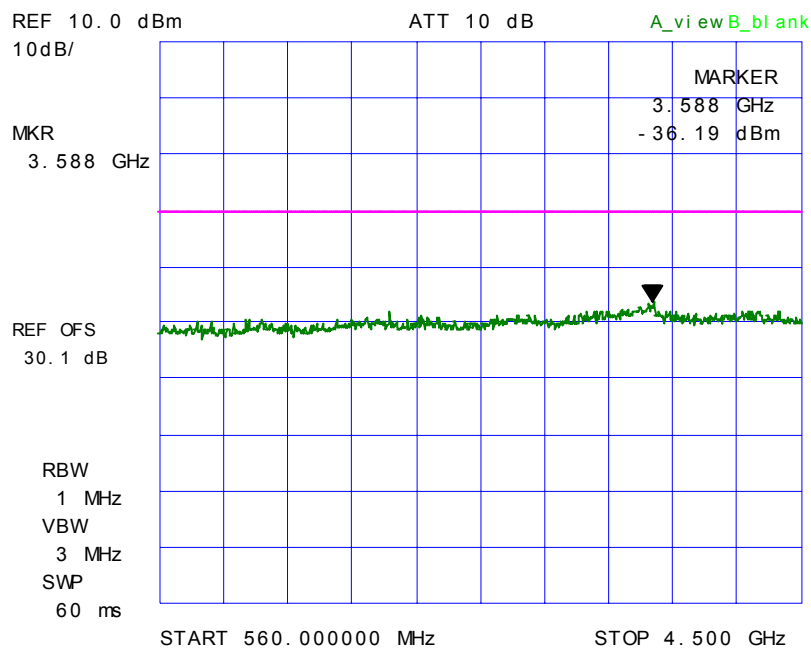

PLOT # 213 Transmitter Conducted Spurious Emissions, High Power
Fc: 391.5 MHz

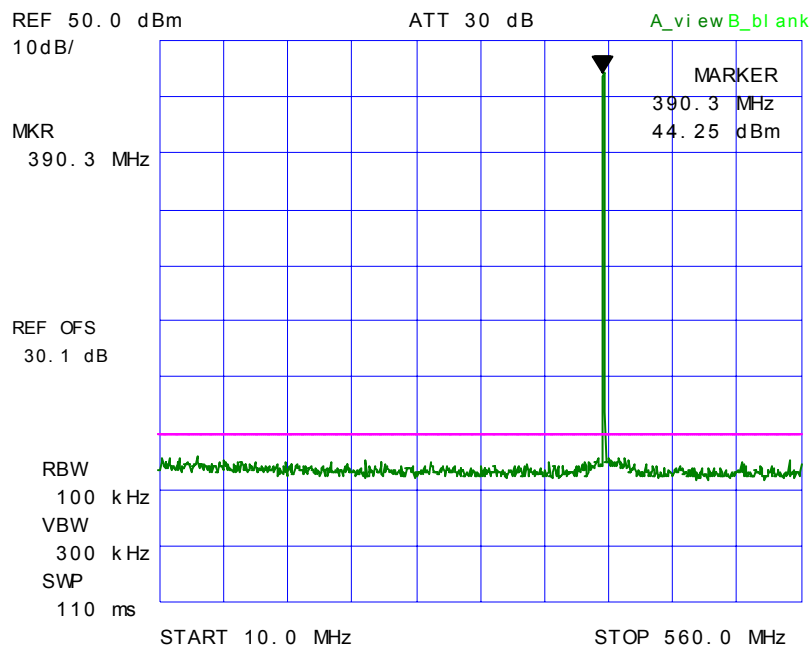

PLOT # 214 Transmitter Conducted Spurious Emissions, High Power
Fc: 391.5 MHz

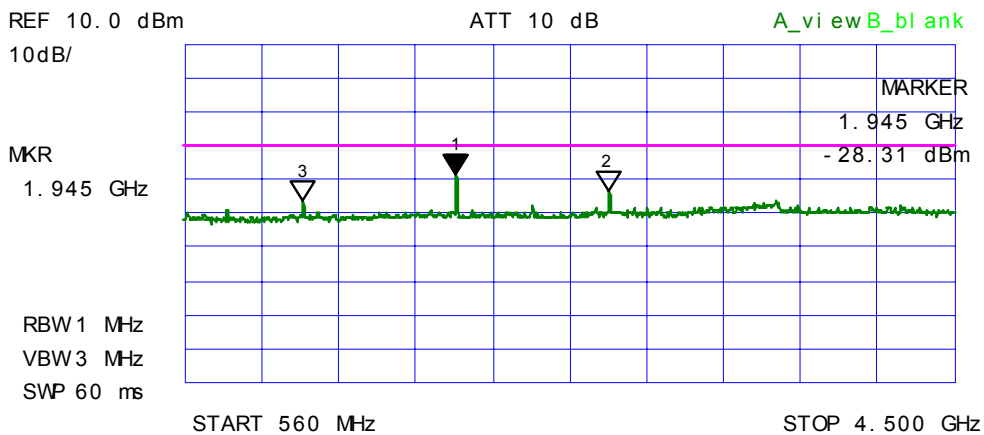

*** Multi Marker List ***

No. 1:	1.945 GHz	-28.31 dBm	A
No. 2:	2.727 GHz	-33.41 dBm	A
No. 3:	1.162 GHz	-36.06 dBm	A
No. 4:			
No. 5:			
No. 6:			
No. 7:			
No. 8:			

**PLOT # 215 Transmitter Conducted Spurious Emissions, Low Power
Fc: 391.5 MHz**

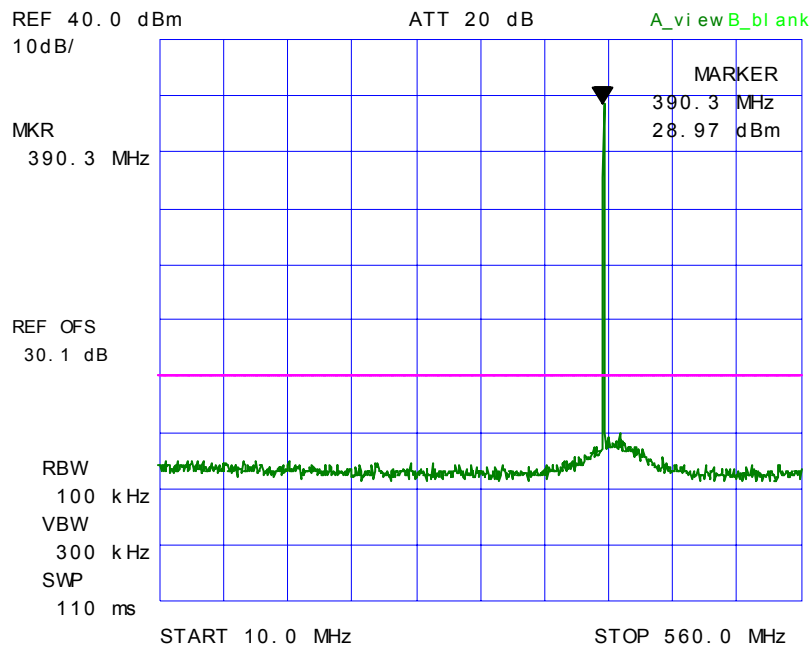

PLOT # 216 Transmitter Conducted Spurious Emissions, Low Power
Fc: 391.5 MHz

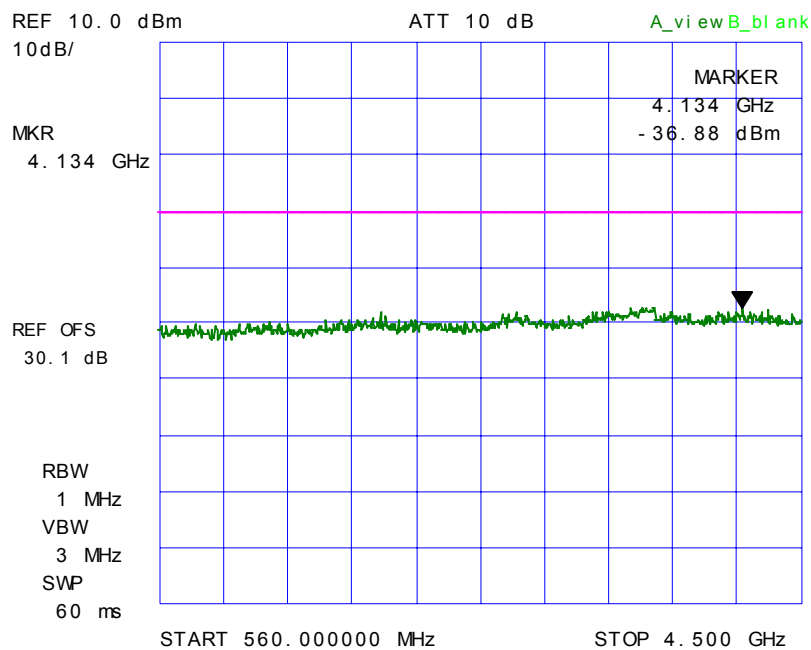

**PLOT # 217 Transmitter Conducted Spurious Emissions, High Power
Fc: 403 MHz**

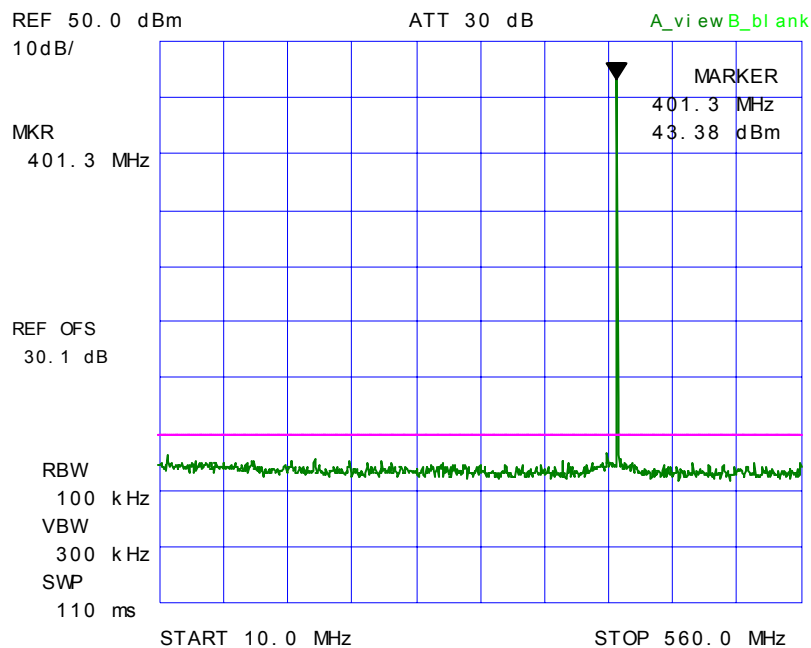

**PLOT # 218 Transmitter Conducted Spurious Emissions, High Power
Fc: 403 MHz**

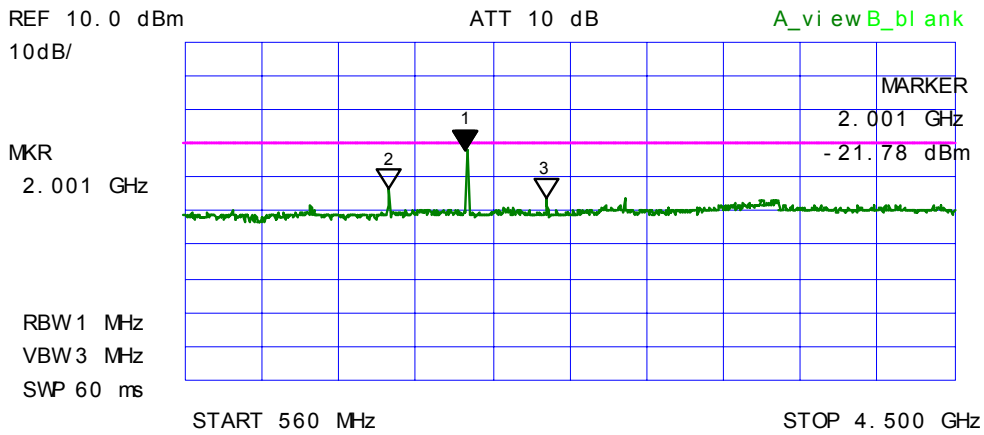

*** Multi Marker List ***

No. 1:	2.001 GHz	-21.78 dBm	A
No. 2:	1.601 GHz	-33.13 dBm	A
No. 3:	2.406 GHz	-36.28 dBm	A
No. 4:			
No. 5:			
No. 6:			
No. 7:			
No. 8:			

**PLOT # 219 Transmitter Conducted Spurious Emissions, Low Power
Fc: 403 MHz**

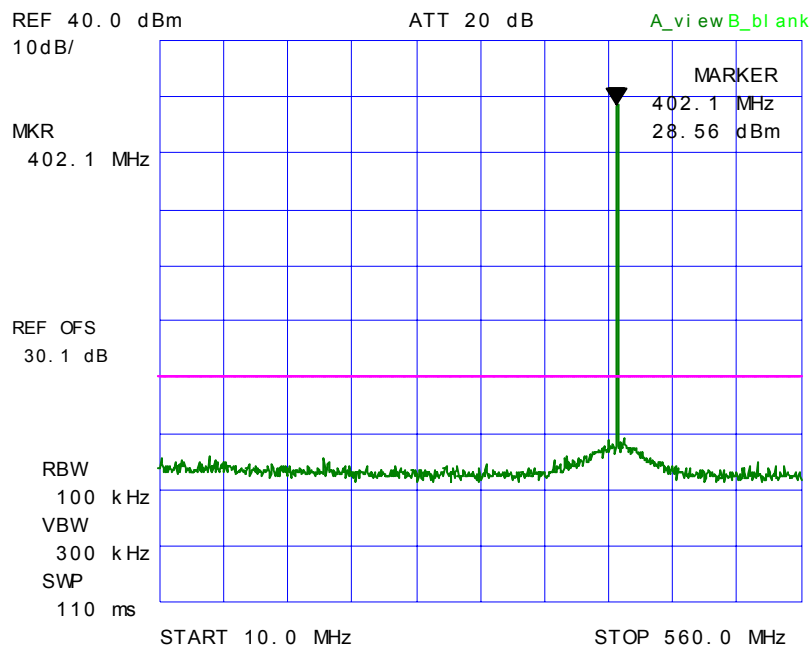

**PLOT # 220 Transmitter Conducted Spurious Emissions, Low Power
Fc: 403 MHz**

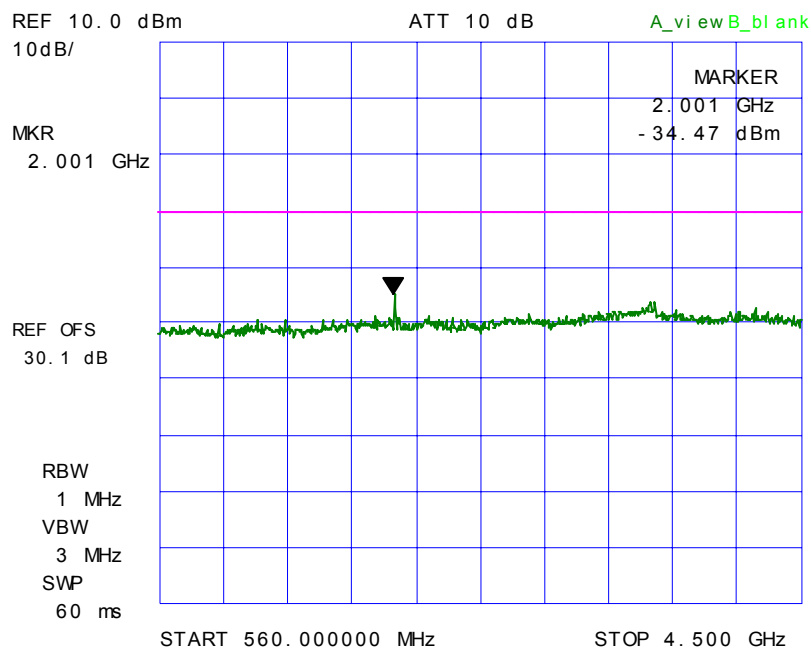

**PLOT # 221 Transmitter Conducted Spurious Emissions, High Power
Fc: 406.1 MHz**

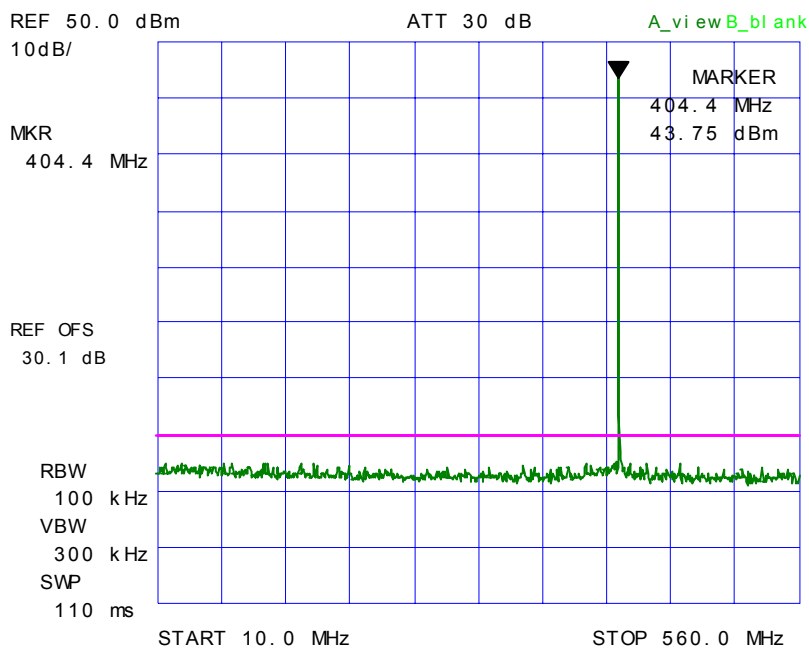

PLOT # 222 Transmitter Conducted Spurious Emissions, High Power
Fc: 406.1 MHz

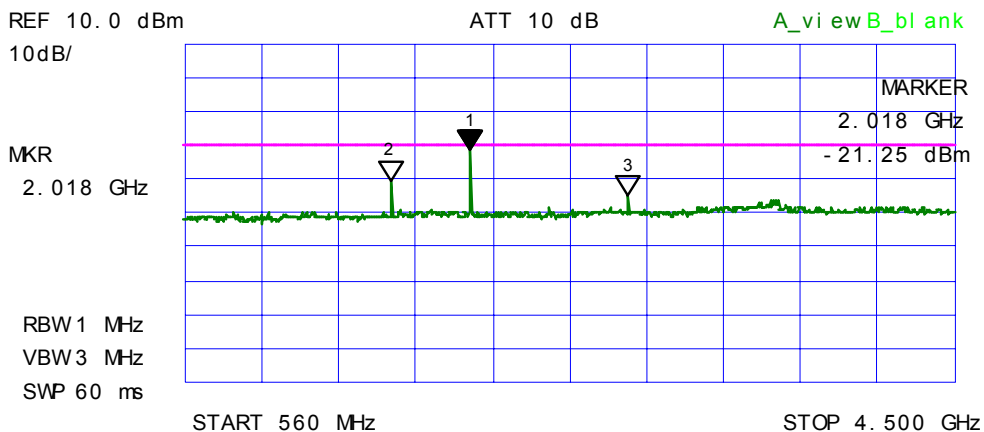

*** Multi Marker List ***

No. 1:	2.018 GHz	-21.25 dBm	A
No. 2:	1.613 GHz	-30.28 dBm	A
No. 3:	2.828 GHz	-34.84 dBm	A
No. 4:			
No. 5:			
No. 6:			
No. 7:			
No. 8:			
Δ:			

**PLOT # 223 Transmitter Conducted Spurious Emissions, Low Power
Fc: 406.1 MHz**

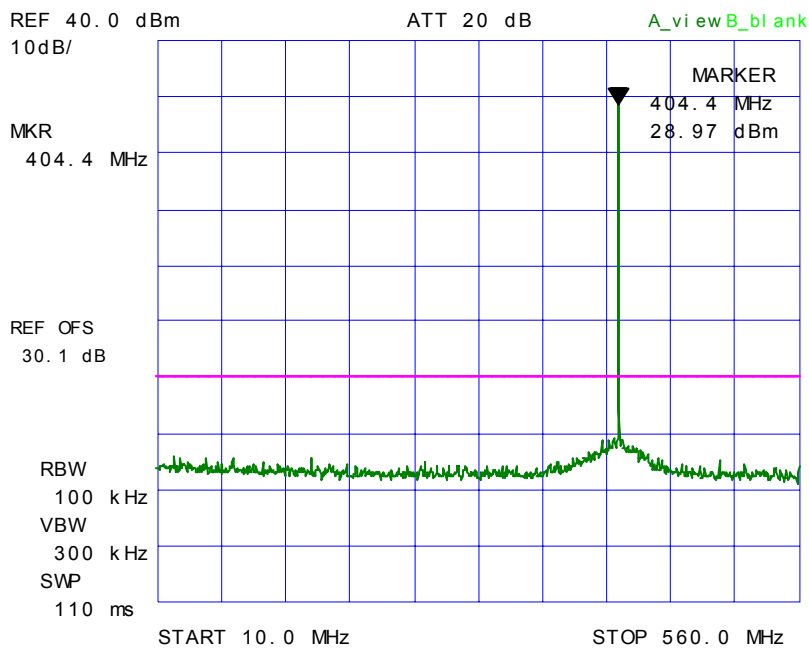

PLOT # 224 Transmitter Conducted Spurious Emissions, Low Power
Fc: 406.1 MHz

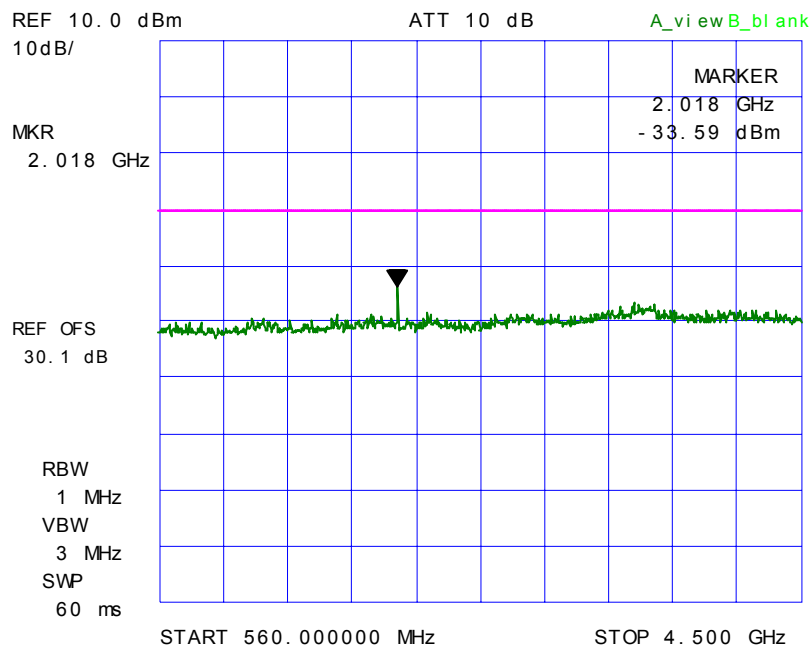

**PLOT # 225 Transmitter Conducted Spurious Emissions, High Power
Fc: 418.05 MHz**

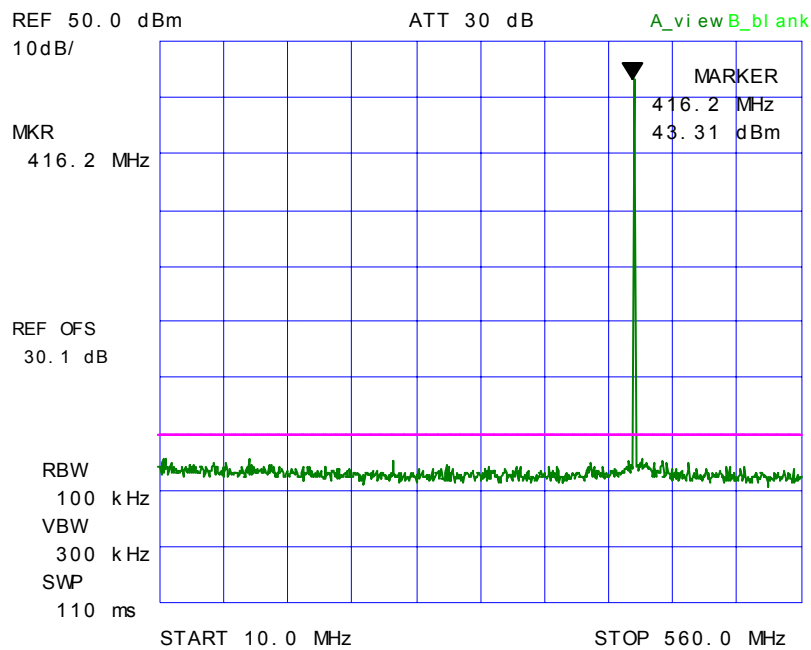

**PLOT # 226 Transmitter Conducted Spurious Emissions, High Power
Fc: 418.05 MHz**

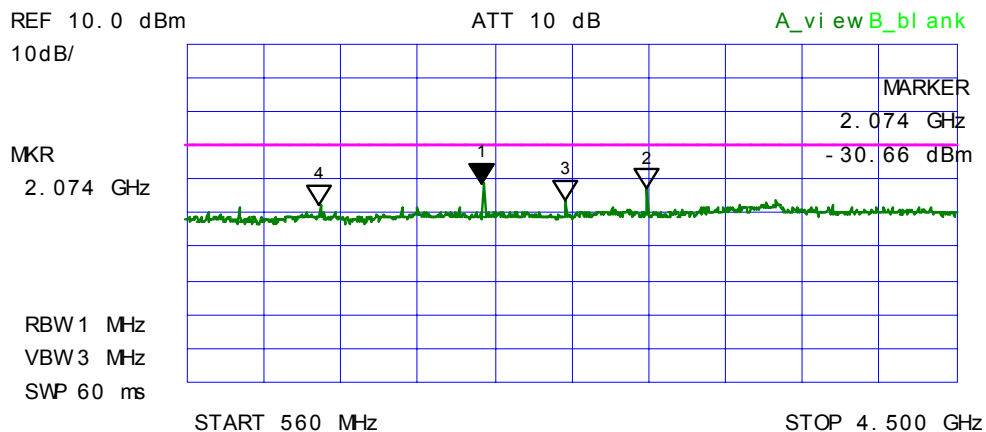

*** Multi Marker List ***

No. 1:	2.074 GHz	-30.66 dBm	A
No. 2:	2.913 GHz	-32.69 dBm	A
No. 3:	2.496 GHz	-35.75 dBm	A
No. 4:	1.241 GHz	-37.31 dBm	A
No. 5:			
No. 6:			
No. 7:			
No. 8:			

**PLOT # 227 Transmitter Conducted Spurious Emissions, Low Power
Fc: 418.05 MHz**

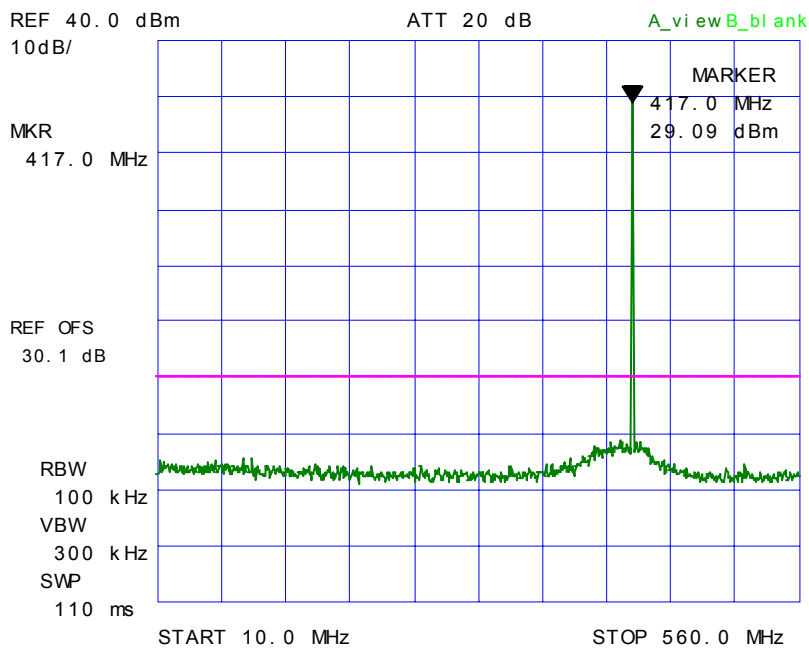

**PLOT # 228 Transmitter Conducted Spurious Emissions, Low Power
Fc: 418.05 MHz**

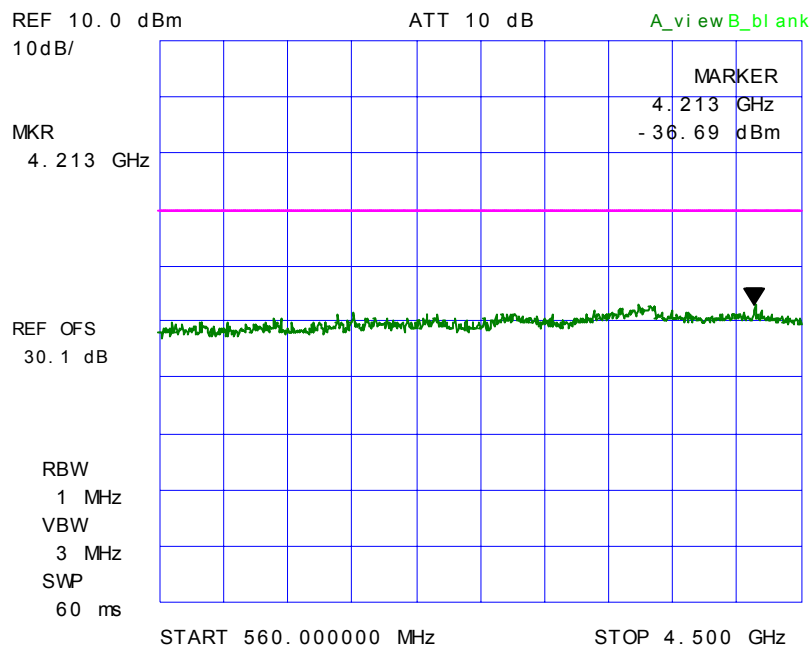

PLOT # 229 Transmitter Conducted Spurious Emissions, High Power
Fc: 430 MHz

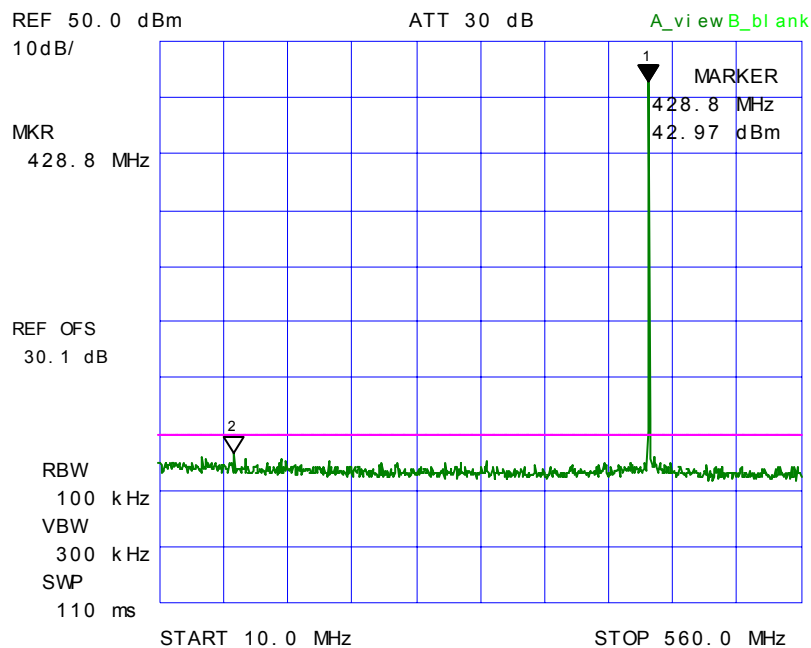

PLOT # 230 Transmitter Conducted Spurious Emissions, High Power
Fc: 430 MHz

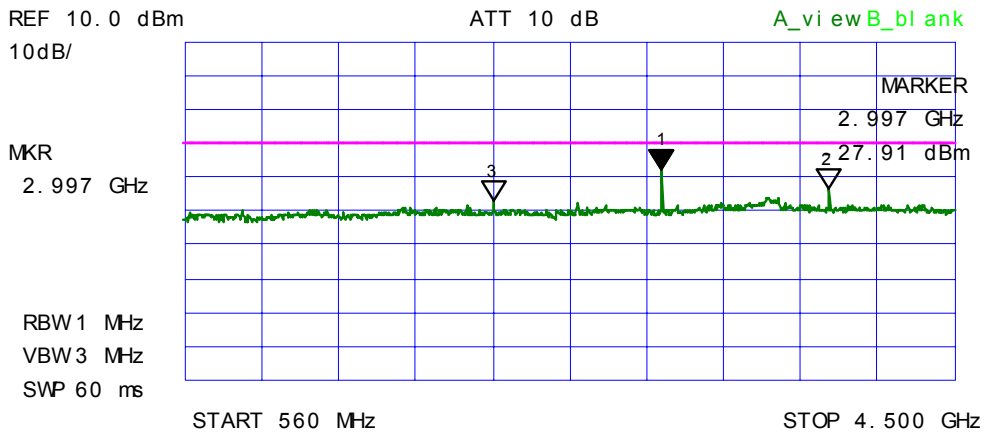

*** Multi Marker List ***

No. 1:	2.997 GHz	-27.91 dBm	A
No. 2:	3.853 GHz	-33.47 dBm	A
No. 3:	2.136 GHz	-36.88 dBm	A
No. 4:			
No. 5:			
No. 6:			
No. 7:			
No. 8:			

PLOT # 231 Transmitter Conducted Spurious Emissions, Low Power
Fc: 430 MHz

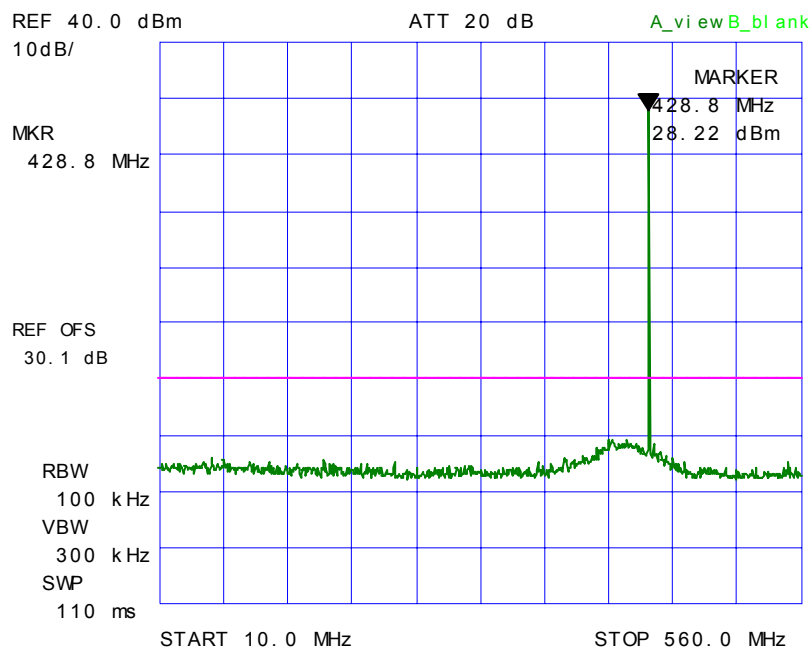

PLOT # 232 Transmitter Conducted Spurious Emissions, Low Power
Fc: 430 MHz

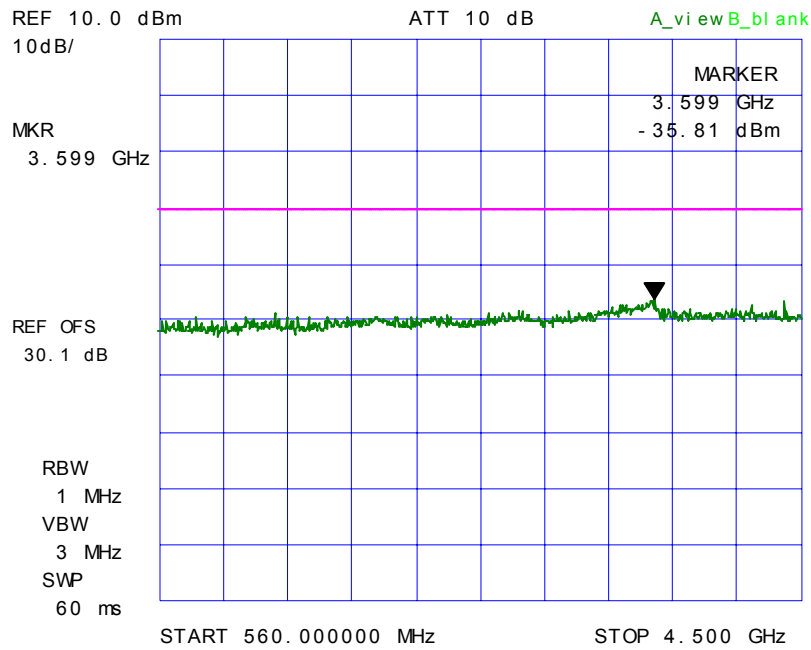

PLOT # 233 Transmitter Conducted Spurious Emissions, High Power
Fc: 450 MHz

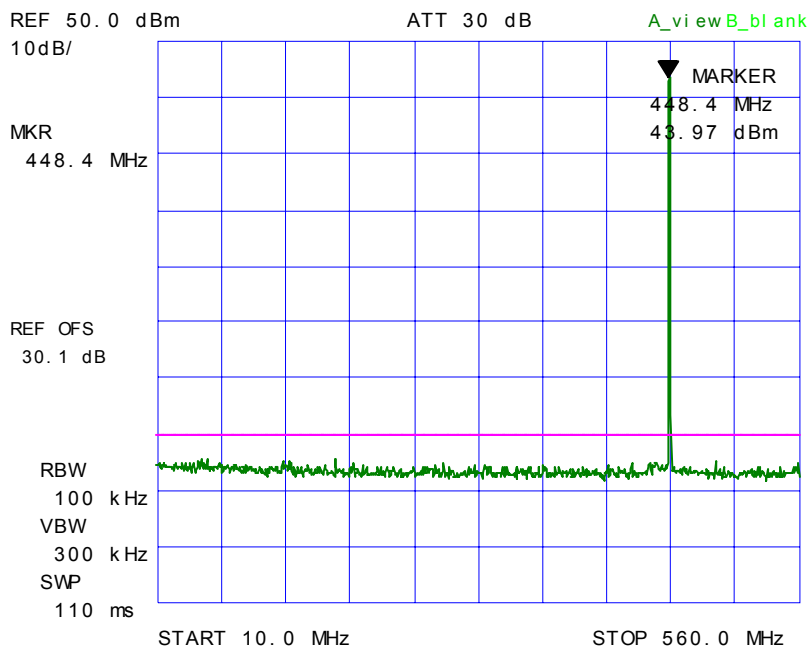

**PLOT # 234 Transmitter Conducted Spurious Emissions, High Power
Fc: 450 MHz**

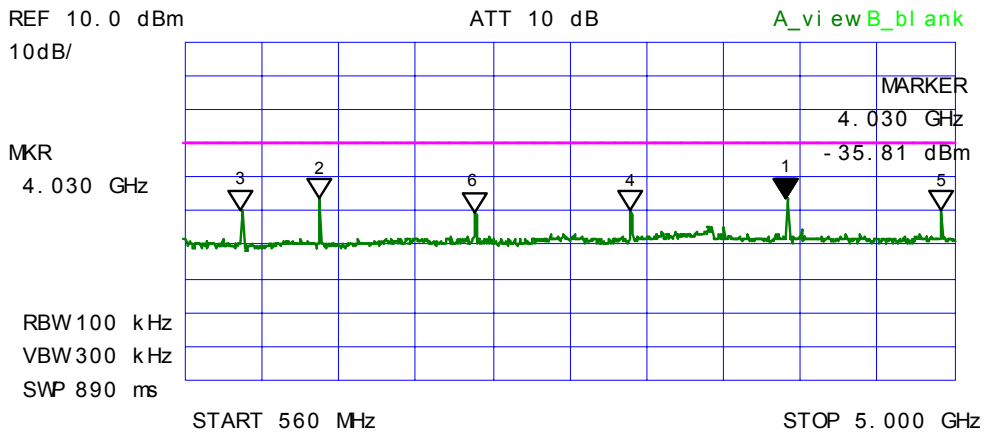

*** Multi Marker List ***

No. 1:	4.030 GHz	-35.81 dBm	A
No. 2:	1.334 GHz	-36.38 dBm	A
No. 3:	883 MHz	-39.25 dBm	A
No. 4:	3.129 GHz	-39.91 dBm	A
No. 5:	4.924 GHz	-40.00 dBm	A
No. 6:	2.228 GHz	-40.16 dBm	A
No. 7:			
No. 8:			

**PLOT # 235 Transmitter Conducted Spurious Emissions, Low Power
Fc: 450 MHz**

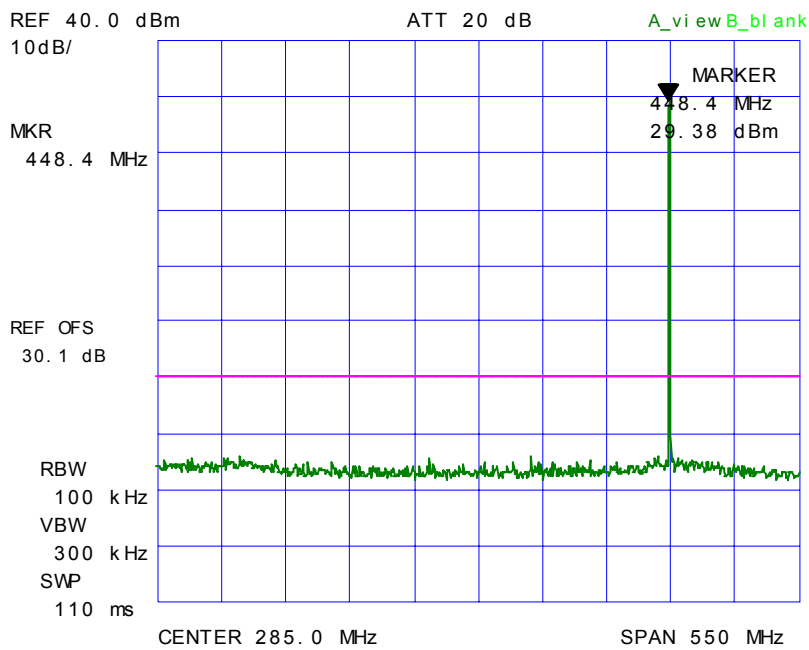

PLOT # 236 Transmitter Conducted Spurious Emissions, Low Power
Fc: 450 MHz

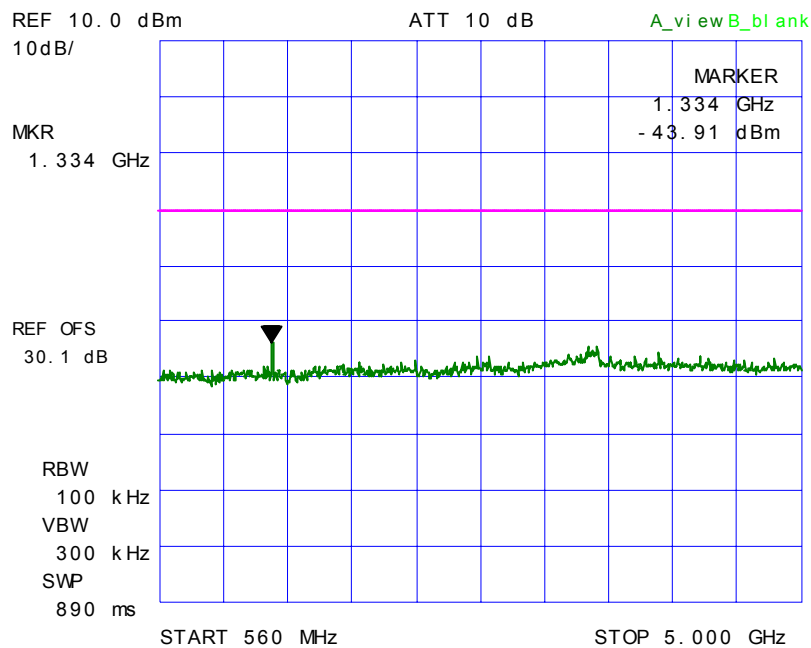

PLOT # 237 Transmitter Conducted Spurious Emissions, High Power
Fc: 460 MHz

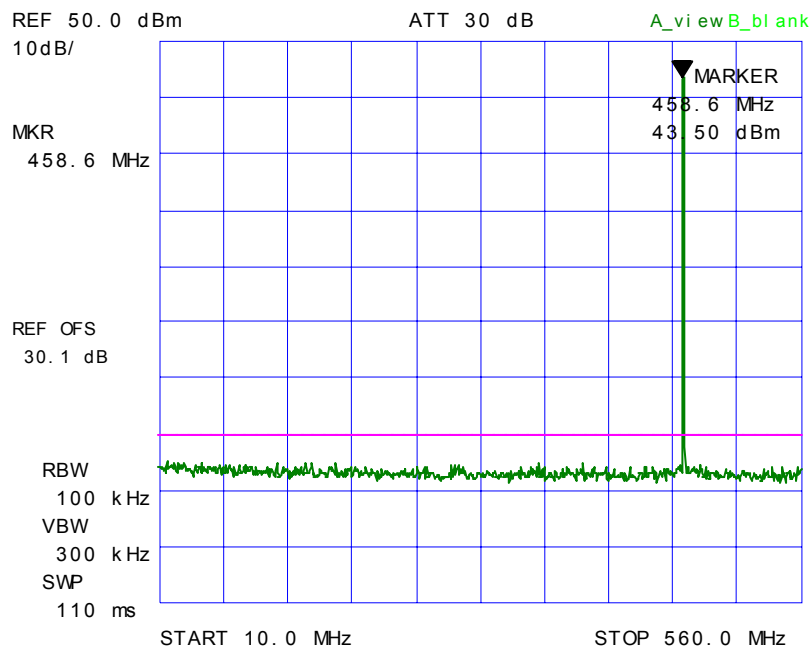

**PLOT # 238 Transmitter Conducted Spurious Emissions, High Power
Fc: 460 MHz**

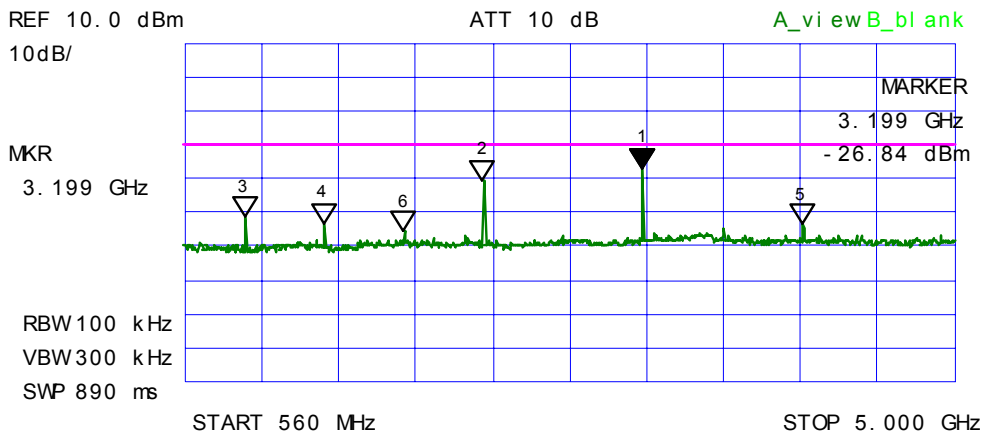

*** Multi Marker List ***

No. 1:	3.199 GHz	-26.84 dBm	A
No. 2:	2.279 GHz	-30.38 dBm	A
No. 3:	903 MHz	-41.28 dBm	A
No. 4:	1.359 GHz	-42.84 dBm	A
No. 5:	4.118 GHz	-43.41 dBm	A
No. 6:	1.822 GHz	-45.44 dBm	A
No. 7:			
No. 8:			

PLOT # 239 Transmitter Conducted Spurious Emissions, Low Power
Fc: 460 MHz

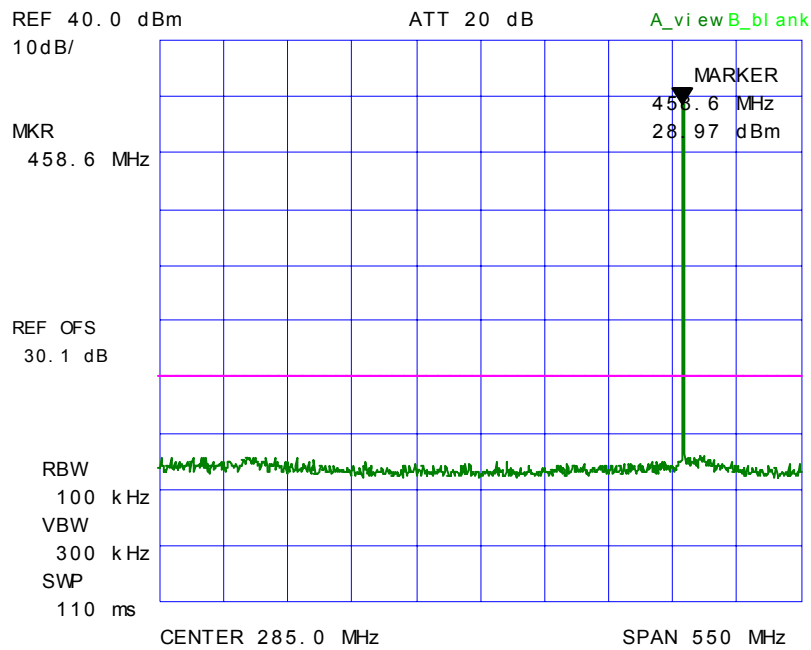

PLOT # 240 Transmitter Conducted Spurious Emissions, Low Power
Fc: 460 MHz

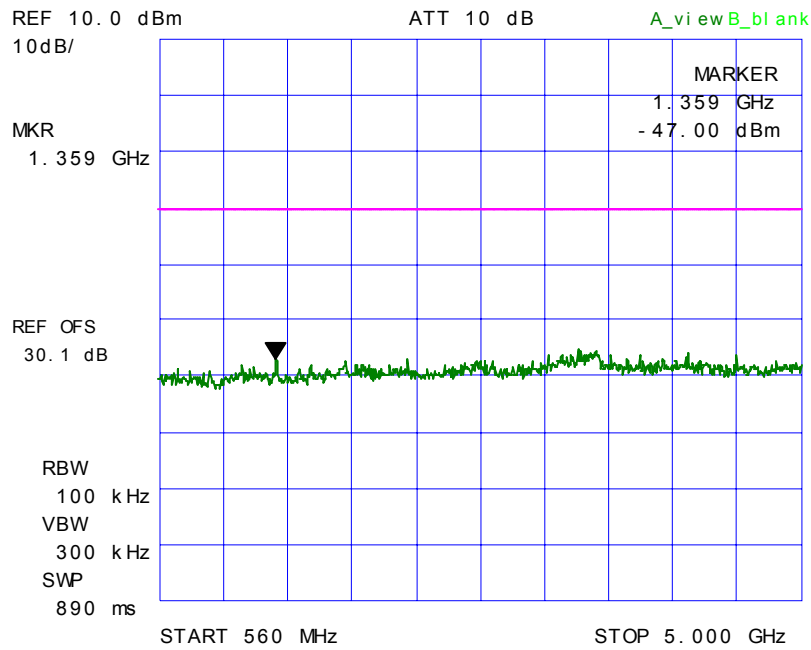

**PLOT # 241 Transmitter Conducted Spurious Emissions, High Power
Fc: 470 MHz**

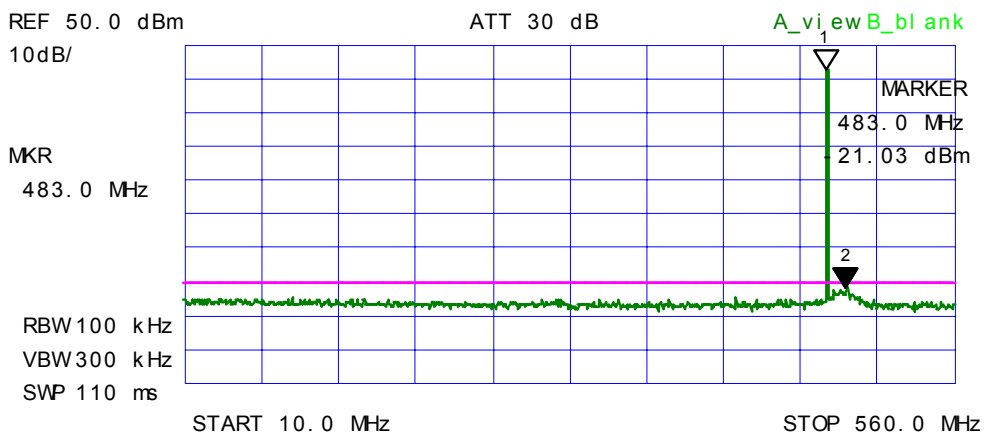

*** Multi Marker List ***

No. 1:	468.1 MHz	43.38 dBm	A
No. 2:	483.0 MHz	-21.03 dBm	A
No. 3:			
No. 4:			
No. 5:			
No. 6:			
No. 7:			
No. 8:			

**PLOT # 242 Transmitter Conducted Spurious Emissions, High Power
Fc: 470 MHz**

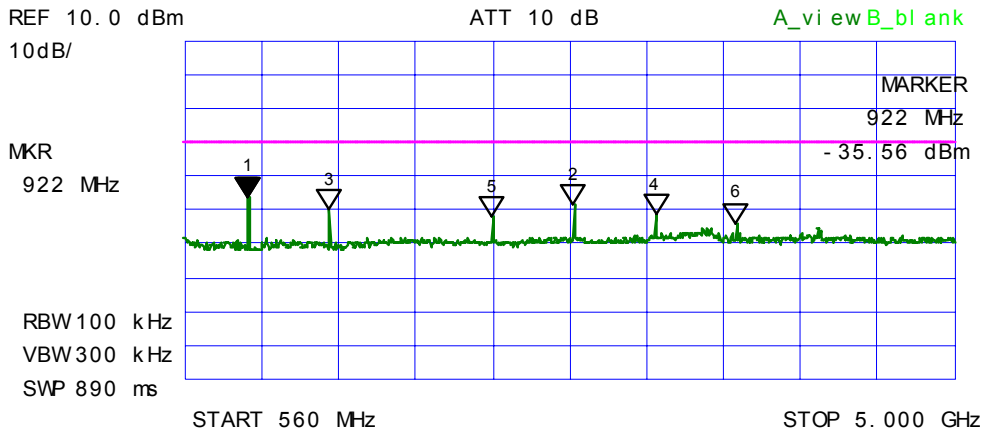

*** Multi Marker List ***

No. 1:	922 MHz	-35.56 dBm	A
No. 2:	2.799 GHz	-38.34 dBm	A
No. 3:	1.391 GHz	-39.63 dBm	A
No. 4:	3.275 GHz	-41.16 dBm	A
No. 5:	2.330 GHz	-41.59 dBm	A
No. 6:	3.738 GHz	-43.97 dBm	A
No. 7:			
No. 8:			

**PLOT # 243 Transmitter Conducted Spurious Emissions, Low Power
Fc: 470 MHz**

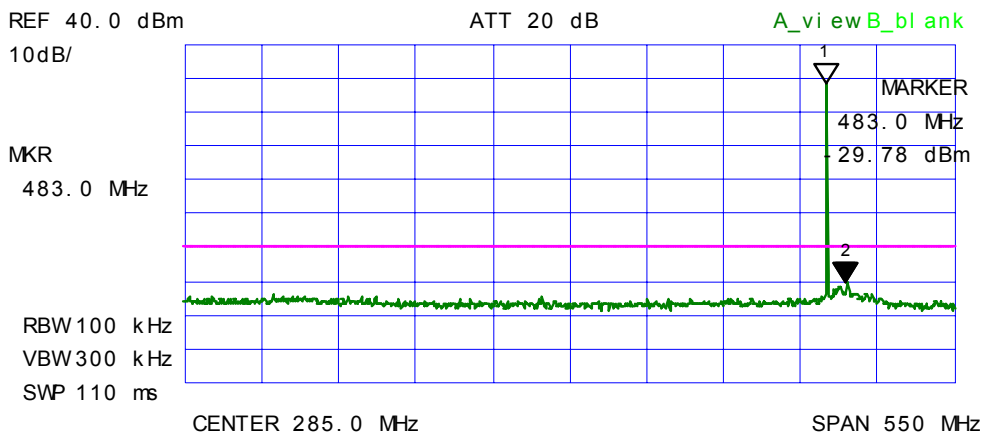

*** Multi Marker List ***

No. 1:	468.1 MHz	28.88 dBm	A
No. 2:	483.0 MHz	-29.78 dBm	A
No. 3:			
No. 4:			
No. 5:			
No. 6:			
No. 7:			
No. 8:			
Δ:			

PLOT # 244 Transmitter Conducted Spurious Emissions, Low Power
Fc: 470 MHz

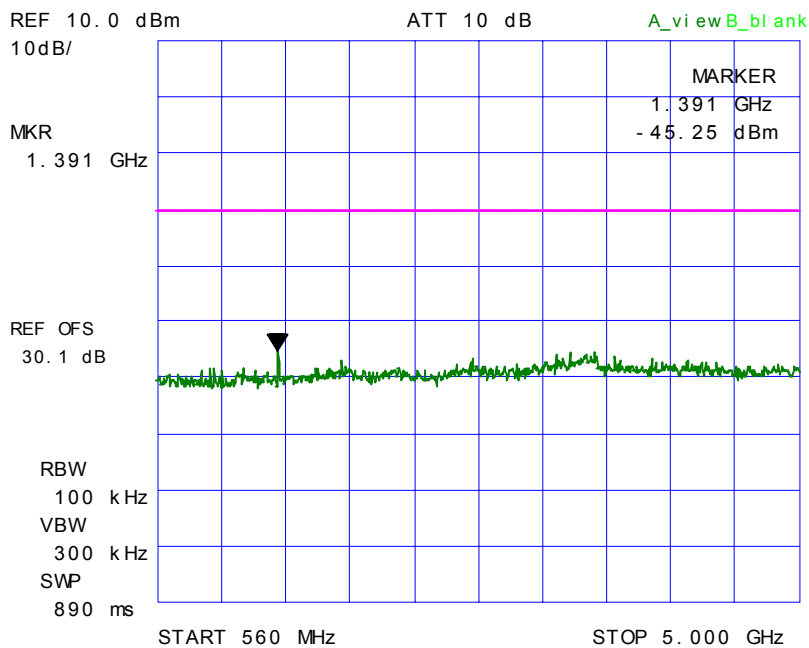

**PLOT # 245 Transmitter Conducted Spurious Emissions, High Power
Fc: 470 MHz**

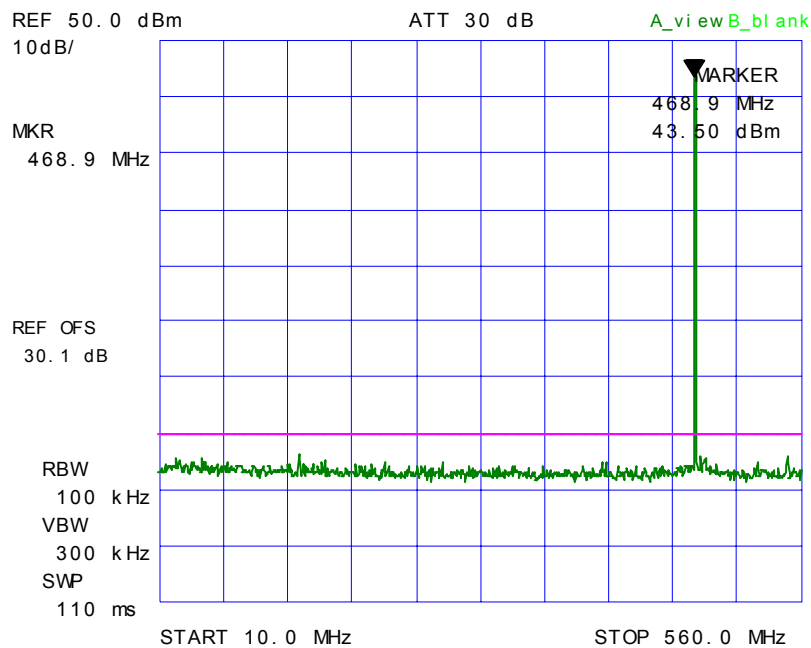

**PLOT # 246 Transmitter Conducted Spurious Emissions, High Power
Fc: 470 MHz**

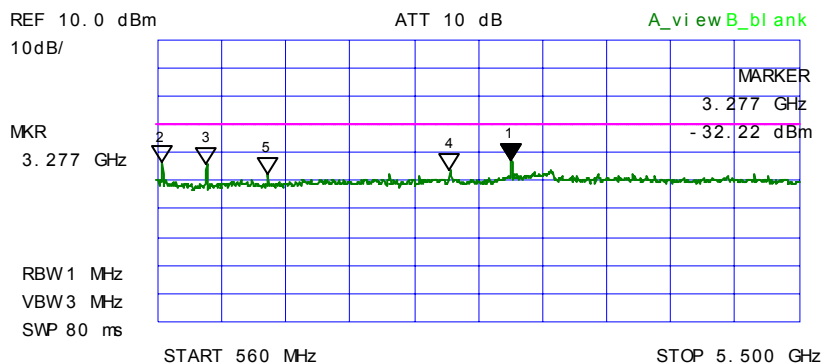

*** Multi Marker List ***

No. 1:	3.277 GHz	-32.22 dBm	A
No. 2:	588 MHz	-33.13 dBm	A
No. 3:	934 MHz	-33.88 dBm	A
No. 4:	2.811 GHz	-35.72 dBm	A
No. 5:	1.400 GHz	-37.06 dBm	A
No. 6:			
No. 7:			
No. 8:			
Δ:			

**PLOT # 247 Transmitter Conducted Spurious Emissions, Low Power
Fc: 470 MHz**

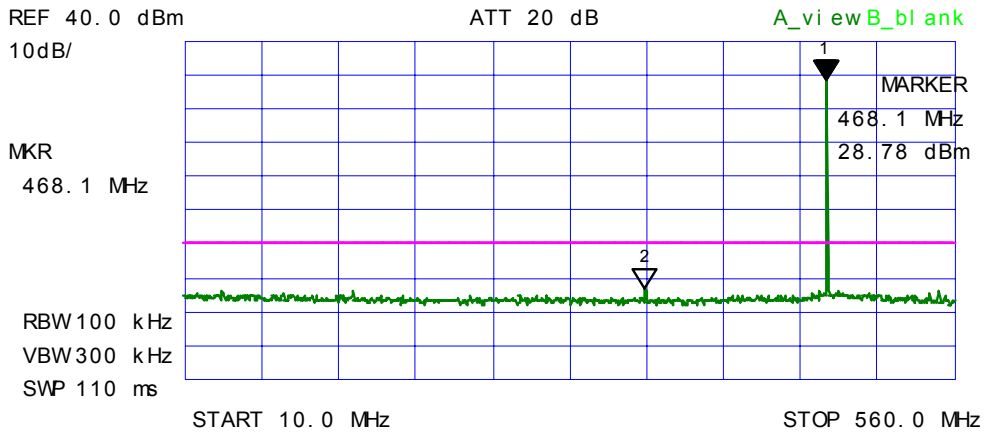

*** Multi Marker List ***

No. 1:	468.1 MHz	28.78 dBm	A
No. 2:	338.4 MHz	-32.63 dBm	A
No. 3:			
No. 4:			
No. 5:			
No. 6:			
No. 7:			
No. 8:			

PLOT # 248 Transmitter Conducted Spurious Emissions, Low Power
Fc: 470 MHz

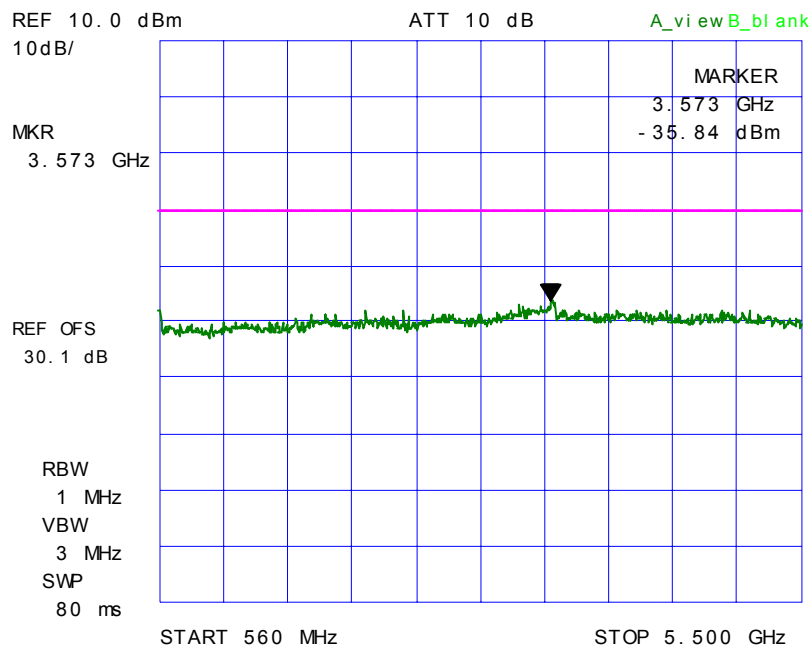

PLOT # 249 Transmitter Conducted Spurious Emissions, High Power
Fc: 491 MHz

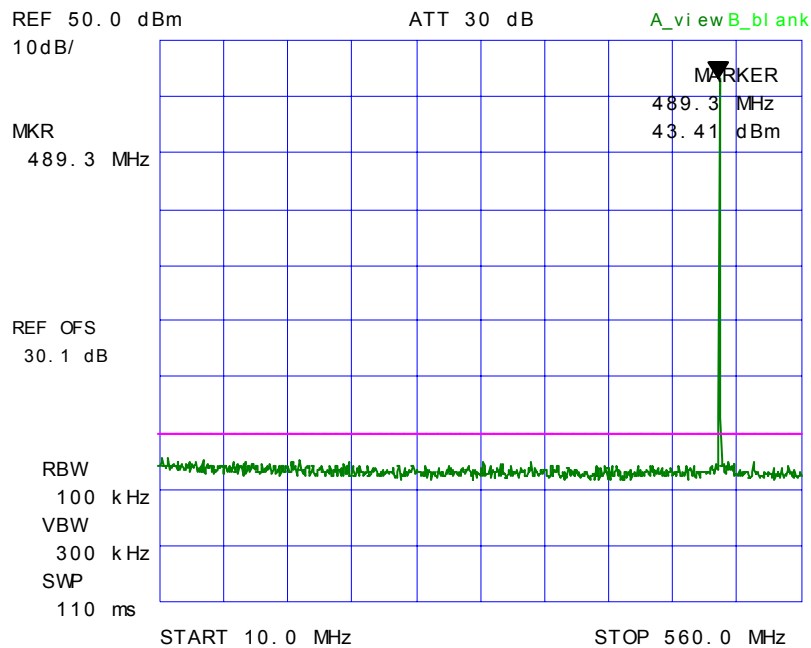

**PLOT # 250 Transmitter Conducted Spurious Emissions, High Power
 Fc: 491 MHz**

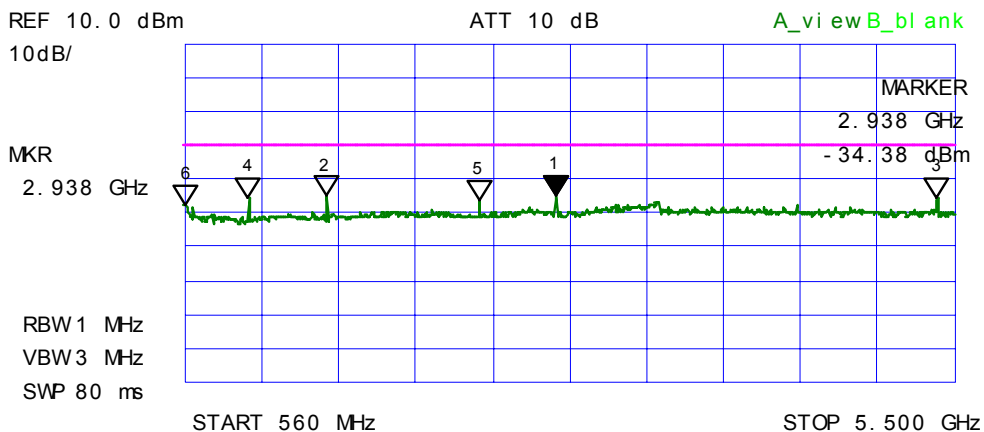

*** Multi Marker List ***

No. 1:	2.938 GHz	-34.38 dBm	A
No. 2:	1.463 GHz	-34.94 dBm	A
No. 3:	5.387 GHz	-35.44 dBm	A
No. 4:	969 MHz	-35.47 dBm	A
No. 5:	2.444 GHz	-35.75 dBm	A
No. 6:	560 MHz	-37.06 dBm	A
No. 7:			
No. 8:			

**PLOT # 251 Transmitter Conducted Spurious Emissions, Low Power
Fc: 491 MHz**

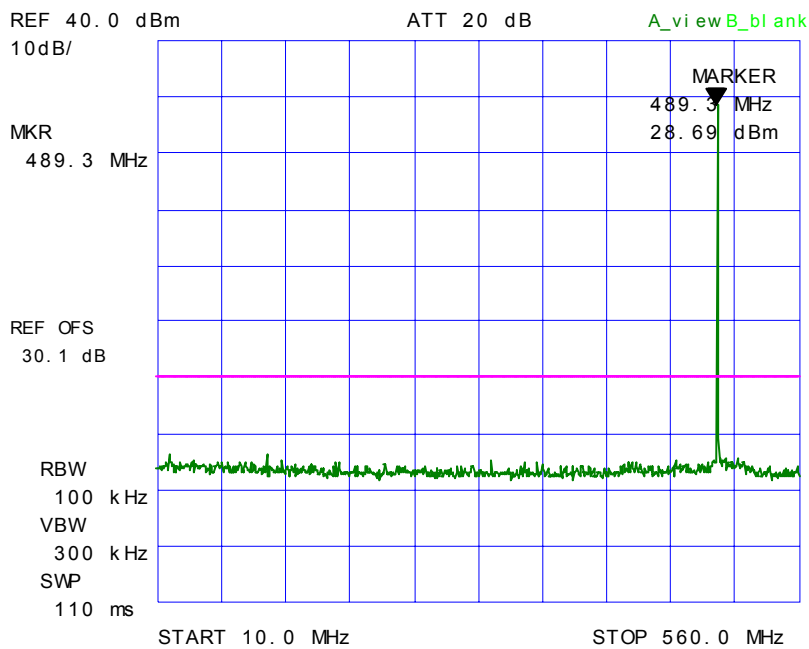

**PLOT # 252 Transmitter Conducted Spurious Emissions, Low Power
Fc: 491 MHz**

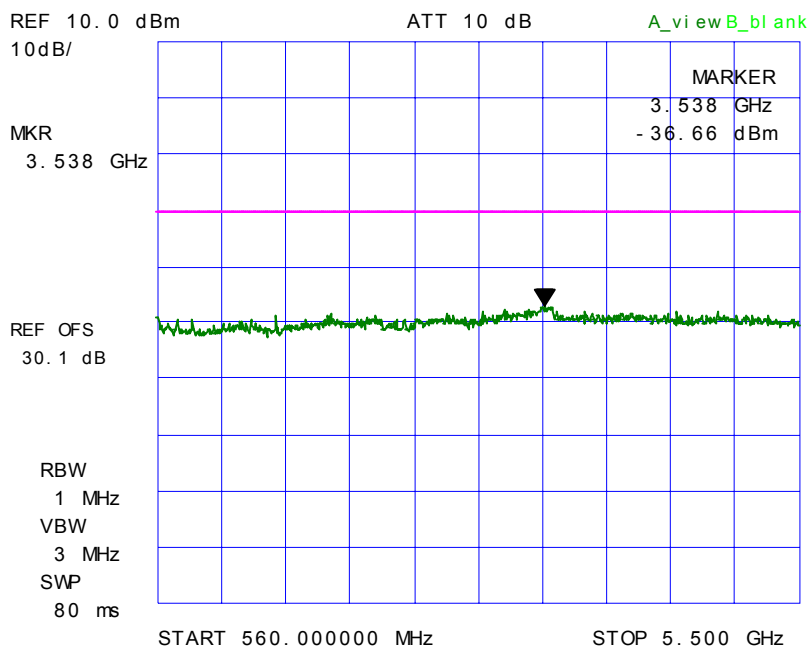

PLOT # 253 Transmitter Conducted Spurious Emissions, High Power
Fc: 512 MHz

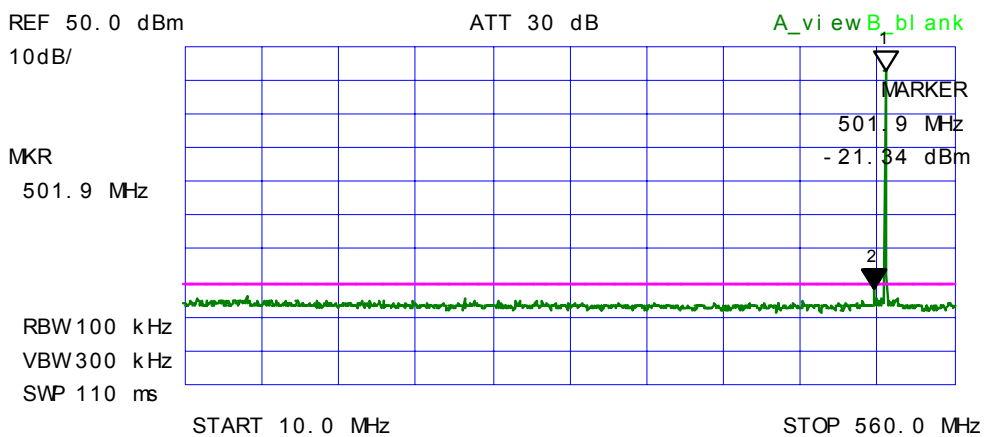

*** Multi Marker List ***

No. 1:	510.5 MHz	43.31 dBm	A
No. 2:	501.9 MHz	-21.34 dBm	A
No. 3:			
No. 4:			
No. 5:			
No. 6:			
No. 7:			
No. 8:			

PLOT # 254 Transmitter Conducted Spurious Emissions, High Power
Fc: 512 MHz

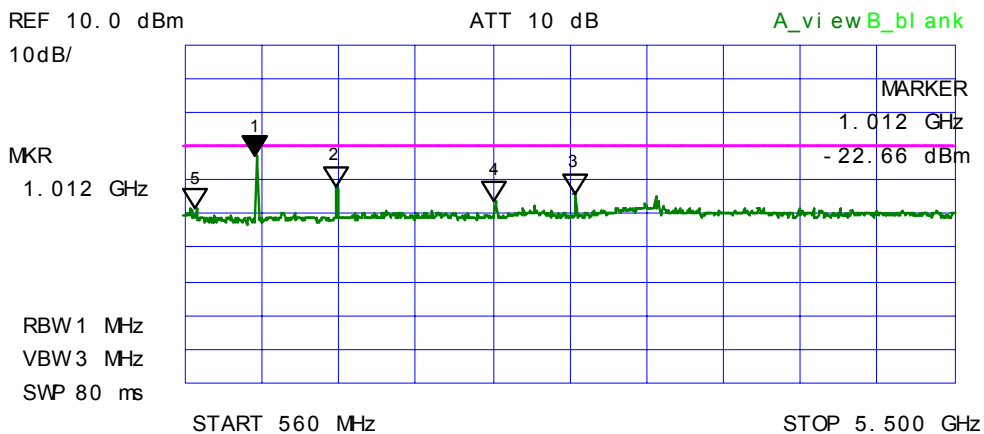

*** Multi Marker List ***

No. 1:	1.012 GHz	-22.66 dBm	A
No. 2:	1.527 GHz	-31.81 dBm	A
No. 3:	3.058 GHz	-33.66 dBm	A
No. 4:	2.550 GHz	-35.97 dBm	A
No. 5:	631 MHz	-38.25 dBm	A
No. 6:			
No. 7:			
No. 8:			

**PLOT # 255 Transmitter Conducted Spurious Emissions, Low Power
Fc: 512 MHz**

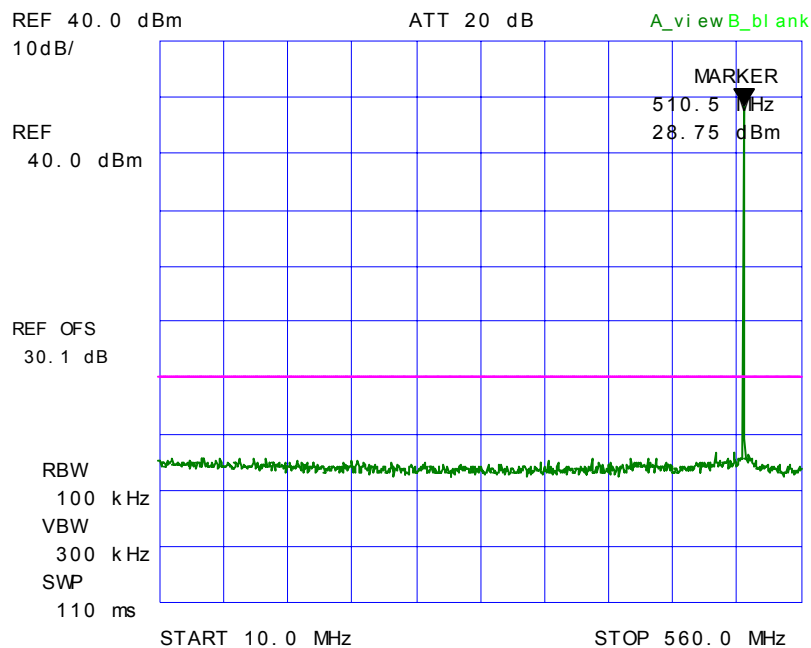

**PLOT # 256 Transmitter Conducted Spurious Emissions, Low Power
Fc: 512 MHz**

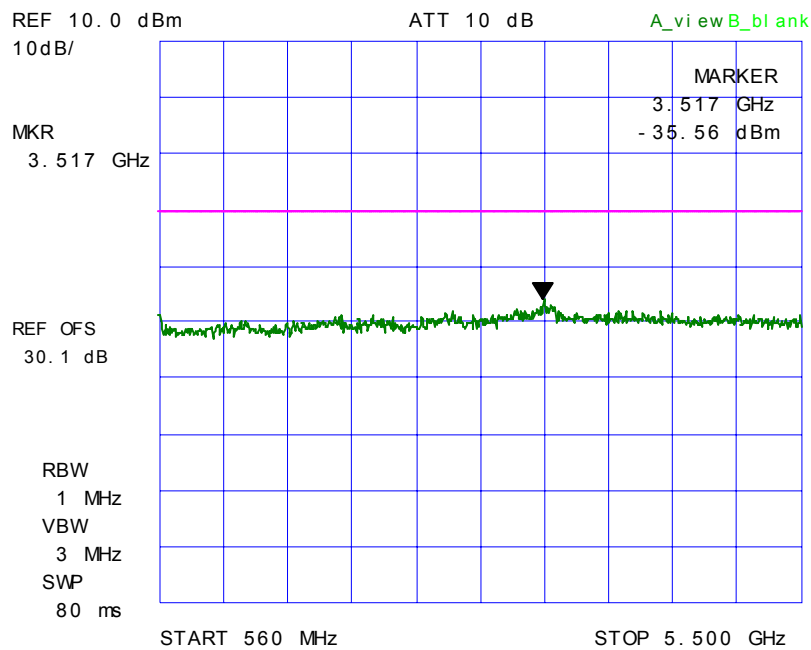

5.12. TRANSMITTER SPURIOUS/HARMONIC RADIATED EMISSIONS [§90.208 & 90.210]

5.12.1. Limits

Emissions shall be attenuated below the mean output power of the transmitter as follows:

FCC Rules	Frequency Range	Attenuation Limit (dBc)
90.210(b)	10 MHz to Lowest frequency of the radio to 10 th harmonic of the highest frequency of the radio	43+10*log(P) or -13 dBm
90.210(d)	10 MHz to Lowest frequency of the radio to 10 th harmonic of the highest frequency of the radio	50+10*log(P) or -20 dBm or 70 dBc whichever is less

5.12.2. Method of Measurements

The spurious/harmonic ERP measurements are using substitution method specified in Exhibit 7, Section 7.2 of this report and its value in dBc is calculated as follows:

- (1) If the transmitter's antenna is an integral part of the EUT, the ERP is measured using substitution method.
- (2) If the transmitter's antenna is non-integral and diverse, the lowest ERP of the carrier with 0 dBi antenna gain is used for calculation of the spurious/harmonic emissions in dBc:
 Lowest ERP of the carrier = EIRP – 2.15 dB = P_c + G - 2.15 dB = xxx dBm (conducted) + 0 dBi – 2.15 dB
- (3) Spurious /harmonic emissions levels expressed in dBc (dB below carrier) are as follows:

$$\text{ERP of spurious/harmonic (dBc)} = \text{ERP of carrier (dBm)} - \text{ERP of spurious/harmonic emission (dBm)}$$

5.12.3. Test Equipment List

Test Instruments	Manufacturer	Model No.	Serial No.	Frequency Range
Spectrum Analyzer/EMI Receiver	Hewlett Packard	HP 8546A	...	9 kHz to 5.6 GHz with built-in 30 dB Gain Pre-selector, QP, Average & Peak Detectors.
RF Amplifier	Com-Power	PA-102		1 MHz to 1 GHz, 30 dB gain nominal
Microwave Amplifier	Hewlett Packard	HP 83017A		1 GHz to 26.5 GHz, 30 dB nominal
Biconilog Antenna	EMCO	3142	10005	30 MHz to 2 GHz
Dipole Antenna	EMCO	3121C	8907-434	30 GHz – 1 GHz
Dipole Antenna	EMCO	3121C	8907-440	30 GHz – 1 GHz
Horn Antenna	EMCO	3155	9701-5061	1 GHz – 18 GHz
Horn Antenna	EMCO	3155	9911-5955	1 GHz – 18 GHz
RF Signal Generator	Hewlett Packard	HP 83752B	3610A00457	0.01 – 20 GHz

5.12.4. Test Data

Remarks:

- The rf spurious/harmonic emission characteristics between 2 different channel spacing operations and different modulations (voice/digital) are identical. Therefore, the following radiated emissions were performed on the radio set with 12.5 kHz channel spacing operation.
- The radiated emissions were performed at 3 meters distance. At its maximum power for worst case.
- The emissions were scanned from 30 MHz to 5 GHz; all emissions that are within 20 dB below the limit are recorded.

5.12.4.1. Frequencies: 380, 391.5, 403, 406.1, 418.05, 430, 450, 460, 470, 491, 512MHz

The emissions were scanned from 30 MHz to 5 GHz at 3 meters distance at all above frequencies and all emissions found were more than 20 dB below the limit.

EXHIBIT 6. MEASUREMENT UNCERTAINTY

The measurement uncertainties stated were calculated in accordance with the requirements of NIST Technical Note 1297 and NIS 81 (1994)

6.1. Radiated Emission Measurement Uncertainty

CONTRIBUTION (Radiated Emissions)	PROBABILITY DISTRIBUTION	UNCERTAINTY (\pm dB)	
		3 m	10 m
Antenna Factor Calibration	Normal (k=2)	± 1.0	± 1.0
Cable Loss Calibration	Normal (k=2)	± 0.3	± 0.5
EMI Receiver specification	Rectangular	± 1.5	± 1.5
Antenna Directivit	Rectangular	+0.5	+0.5
Antenna factor variation with height	Rectangular	± 2.0	± 0.5
Antenna phase center variation	Rectangular	0.0	± 0.2
Antenna factor frequency interpolation	Rectangular	± 0.25	± 0.25
Measurement distance variation	Rectangular	± 0.6	± 0.4
Site imperfections	Rectangular	± 2.0	± 2.0
Mismatch: Receiver VRC $\Gamma_1 = 0.2$ Antenna VRC $\Gamma_R = 0.67$ (Bi) 0.3 (Lp) Uncertainty limits $20\text{Log}(1 \pm \Gamma_1 \Gamma_R)$	U-Shaped	+1.1 -1.25	± 0.5
System repeatability	Std. Deviation	± 0.5	± 0.5
Repeatability of EUT		-	-
Combined standard uncertainty	Normal	+2.19 / -2.21	+1.74 / -1.72
Expanded uncertainty U	Normal (k=2)	+4.38 / -4.42	+3.48 / -3.44

Calculation for maximum uncertainty when 3m biconical antenna including a factor of k = 2 is used:

$$U = 2u_c(y) = 2x(+2.19) = +4.38 \text{ dB} \quad \text{And} \quad U = 2u_c(y) = 2x(-2.21) = -4.42 \text{ dB}$$

EXHIBIT 7. MEASUREMENT METHODS

7.1. CONDUCTED POWER MEASUREMENTS

- The following shall be applied to the combination(s) of the radio device and its intended antenna(e).
- If the RF level is user adjustable, all measurements shall be made with the highest power level available to the user for that combination.
- The following method of measurement shall apply to both conducted and radiated measurements.
- The radiated measurements are performed at the Ultratech Calibrated Open Field Test Site.
- The measurement shall be performed using normal operation of the equipment with modulation.

Test procedure shall be as follows:

Step 1: Duty Cycle measurements if the transmitter's transmission is transient

- Using a EMI Receiver with the frequency span set to 0 Hz and the sweep time set at a suitable value to capture the envelope peaks and the duty cycle of the transmitter output signal;
- The duty cycle of the transmitter, $x = T_x \text{ on} / (T_x \text{ on} + T_x \text{ off})$ with $0 < x < 1$, is measure and recorded in the test report. For the purpose of testing, the equipment shall be operated with a duty cycle that is equal or more than 0.1.

Step 2: Calculation of Average EIRP. See Figure 1

- The average output power of the transmitter shall be determined using a wideband, calibrated RF average power meter with the power sensor with an integration period that exceeds the repetition period of the transmitter by a factor 5 or more. The observed value shall be recorded as "A" (in dBm);
- The e.i.r.p. shall be calculated from the above measured power output "A", the observed duty cycle x, and the applicable antenna assembly gain "G" in dBi, according to the formula:

$$\text{EIRP} = \text{A} + \text{G} + 10\log(1/x)$$

{ X = 1 for continuous transmission => $10\log(1/x) = 0 \text{ dB}$ }

Figure 1.

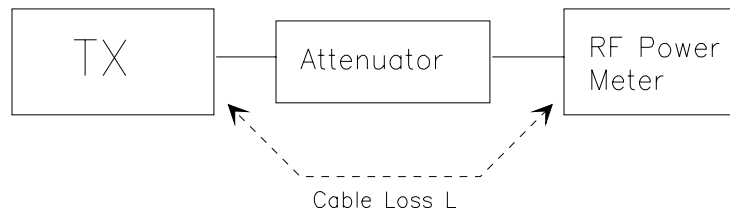

7.2. RADIATED POWER MEASUREMENTS (ERP & EIRP) USING SUBSTITUTION METHOD

7.2.1. Maximizing RF Emission Level (E-Field)

- (a) The measurements were performed with full rf output power and modulation.
- (b) Test was performed at listed 3m open area test site (listed with FCC, IC, ITI, NVLAP, ACA & VCCI).
- (c) The transmitter under test was placed at the specified height on a non-conducting turntable (80 cm height)
- (d) The BICONILOG antenna (20 MHz to 1 GHz) or HORN antenna (1 GHz to 18 GHz) was used for measuring.
- (e) Load an appropriate correction factors file in EMI Receiver for correcting the field strength reading level

Total Correction Factor recorded in the EMI Receiver = Cable Loss + Antenna Factor
 $E \text{ (dB}\mu\text{V/m)} = \text{Reading (dB}\mu\text{V)} + \text{Total Correction Factor (dB/m)}$

- (f) Set the EMI Receiver and #2 as follows:

Center Frequency: test frequency
Resolution BW: 100 kHz
Video BW: same
Detector Mode: positive
Average: off
Span: 3 x the signal bandwidth

- (g) The test antenna was lowered or raised from 1 to 4 meters until the maximum signal level was detected.
- (h) The transmitter was rotated through 360° about a vertical axis until a higher maximum signal was received.
- (i) The test antenna was lowered or raised again from 1 to 4 meters until a maximum was obtained. This level was recorded.
- (j) The recorded reading was corrected to the true field strength level by adding the antenna factor, cable loss and subtracting the pre-amplifier gain.
- (k) The above steps were repeated with both transmitters' antenna and test receiving antenna placed in vertical and horizontal polarization. Both readings with the antennas placed in vertical and horizontal polarization shall be recorded.
- (l) Repeat for all different test signal frequencies.

7.2.2. Measuring the EIRP of Spurious/Harmonic Emissions using Substitution Method

- (a) Set the EMI Receiver (for measuring E-Field) and Receiver #2 (for measuring EIRP) as follows:

Center Frequency: equal to the signal source
Resolution BW: 10 kHz
Video BW: same
Detector Mode: positive
Average: off
Span: 3 x the signal bandwidth

- (b) Load an appropriate correction factors file in EMI Receiver for correcting the field strength reading level

Total Correction Factor recorded in the EMI Receiver = Cable Loss + Antenna Factor
 $E \text{ (dBuV/m)} = \text{Reading (dBuV)} + \text{Total Correction Factor (dB/m)}$

- (c) Select the frequency and E-field levels obtained in the Section 8.2.1 for ERP/EIRP measurements.
(d) Substitute the EUT by a signal generator and one of the following transmitting antenna (substitution antenna):
 - ◆ DIPOLE antenna for frequency from 30-1000 MHz or
 - ◆ HORN antenna for frequency above 1 GHz }(e) Mount the transmitting antenna at 1.5 meter high from the ground plane.
(f) Use one of the following antenna as a receiving antenna:
 - ◆ DIPOLE antenna for frequency from 30-1000 MHz or
 - ◆ HORN antenna for frequency above 1 GHz }(g) If the DIPOLE antenna is used, tune it's elements to the frequency as specified in the calibration manual.
(h) Adjust both transmitting and receiving antenna in a VERTICAL polarization.
(i) Tune the EMI Receivers to the test frequency.
(j) Lower or raise the test antenna from 1 to 4 meters until the maximum signal level was detected.
(k) The transmitter was rotated through 360° about a vertical axis until a higher maximum signal was received.
(l) Lower or raise the test antenna from 1 to 4 meters until the maximum signal level was detected.
(m) Adjust input signal to the substitution antenna until an equal or a known related level to that detected from the transmitter was obtained in the test receiver.
(n) Record the power level read from the Average Power Meter and calculate the ERP/EIRP as follows:

$$P = P1 - L1 = (P2 + L2) - L1 = P3 + A + L2 - L1$$

$$EIRP = P + G1 = P3 + L2 - L1 + A + G1$$

$$ERP = EIRP - 2.15 \text{ dB}$$

$$\text{Total Correction factor in EMI Receiver \# 2} = L2 - L1 + G1$$

Where: P: Actual RF Power fed into the substitution antenna port after corrected.
P1: Power output from the signal generator
P2: Power measured at attenuator A input
P3: Power reading on the Average Power Meter
EIRP: EIRP after correction
ERP: ERP after correction

- (o) Adjust both transmitting and receiving antenna in a HORIZONTAL polarization, then repeat step (k) to (o)
(p) Repeat step (d) to (o) for different test frequency
(q) Repeat steps (c) to (j) with the substitution antenna oriented in horizontal polarization.
(r) Actual gain of the EUT's antenna is the difference of the measured EIRP and measured RF power at the RF port. Correct the antenna gain if necessary.

Figure 2

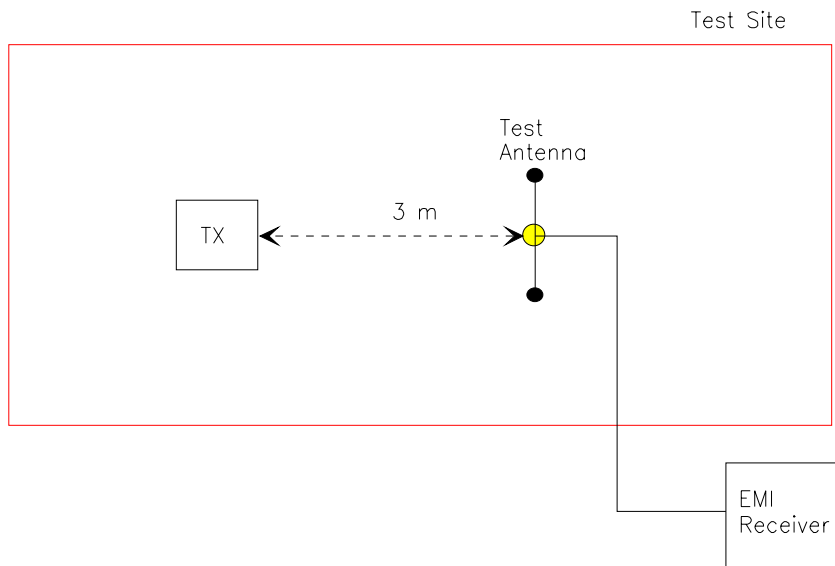
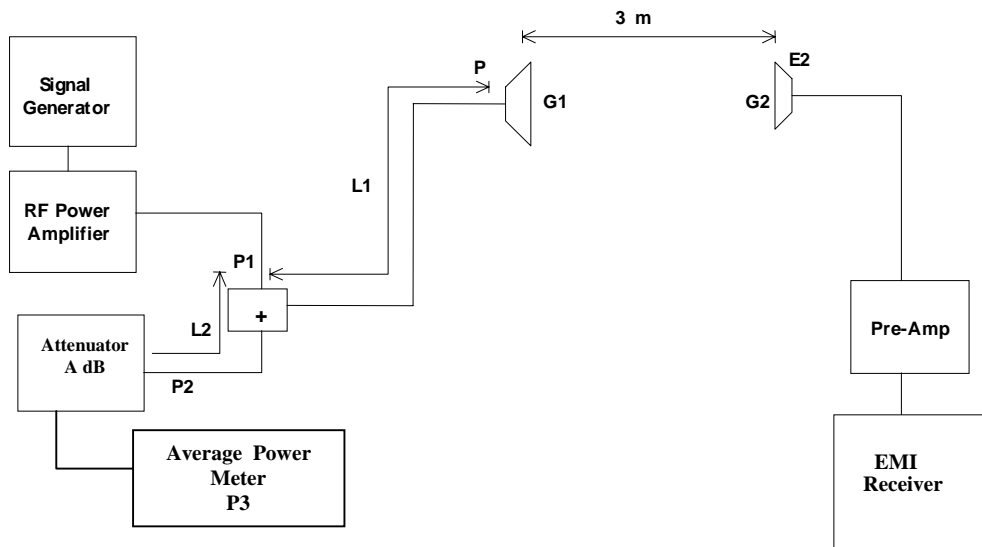

Figure 3



7.3. SPURIOUS EMISSIONS (CONDUCTED)

With transmitter modulation characteristics described in Out-of-Band Emissions measurements @ 2.1049, the transmitter spurious and harmonic emissions were scanned. The spurious and harmonic emissions were measured with the EMI Receiver controls set as RBW = 30 kHz minimum , VBW \geq RBW and SWEEP TIME = AUTO). The transmitter was operated at a full rated power output, and modulated as follows:

FCC CFR 47, Para. 2.1057 - Frequency spectrum to be investigated:- The spectrum was investigated from the lowest radio generated in the equipment up to at least the 10th harmonic of the carrier frequency or to the highest frequency practicable in the present state of the art of measuring techniques, whichever is lower. Particular attention should be paid to harmonics and subharmonics of the carrier frequency. Radiation at the frequencies of multiplier stages should be checked. The amplitude of spurious emissions which are attenuated more than 20 dB below the permissible value need not be reported.

FCC CFR 47, Para. 2.1051 - Spurious Emissions at Antenna Terminal:- The radio frequency voltage or powers generated within the equipment and appearing on a spurious frequency shall be checked at the equipment output terminals when properly loaded with a suitable artificial antenna. Curves or equivalent data shall show the magnitude of the harmonic and other spurious emission that can be detected when the equipment is operated under the conditions specified in 2.1049 as appropriate. The magnitude of spurious emissions which are attenuated more than 20 dB below the permissible value need not be specified.