

# ENGINEERING TEST REPORT

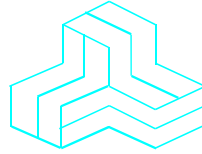

## PAGING ON-CHANNEL REPEATER (OCR P)

**Model No.: OCR 900P**

**FCC ID: LO6-OCR900P**

*Applicant:*

**Futurecom Systems Group Inc**

3277 Langstaff Road

Concord, Ontario

Canada, L4K 5P8

*Tested in Accordance With*

**Federal Communications Commission (FCC)**

**47 CFR, Parts 2 and 22 (Subpart E)**

**UltraTech's File No.: FSG-084F22E**

This Test report is Issued under the Authority of  
Tri M. Luu, Professional Engineer,  
Vice President of Engineering  
UltraTech Group of Labs



Date: April 02, 2008

Report Prepared by: Dharmajit Solanki, RFI Engineer

Tested by: Mr. Hung Trinh & Mr. Wayne, RFI/EMC Technicians

Issued Date: April 02, 2008

Test Dates: Mar. 06 – April 01, 2008

- *The results in this Test Report apply only to the sample(s) tested, and the sample tested is randomly selected.*
- *This report must not be used by the client to claim product endorsement by NVLAP or any agency of the US Government.*

## UltraTech

3000 Bristol Circle, Oakville, Ontario, Canada, L6H 6G4

Tel.: (905) 829-1570 Fax.: (905) 829-8050

Website: [www.ultratech-labs.com](http://www.ultratech-labs.com), Email: [vic@ultratech-labs.com](mailto:vic@ultratech-labs.com), Email: [tri@ultratech-labs.com](mailto:tri@ultratech-labs.com)



0685



31040/SIT



C-1376



Industry Canada  
Industrie Canada

Approved Test Facility

46390-2049



200093-0



SL2-IN-E-1119R

**Korea  
MIC-RRL**

2005-82 & 83

## TABLE OF CONTENTS

<b>EXHIBIT 1. INTRODUCTION</b> .....	<b>3</b>
1.1. SCOPE.....	3
1.2. RELATED SUBMITTAL(S)/GRANT(S).....	3
1.3. NORMATIVE REFERENCES .....	3
<b>EXHIBIT 2. PERFORMANCE ASSESSMENT</b> .....	<b>4</b>
2.1. CLIENT INFORMATION .....	4
2.2. EQUIPMENT UNDER TEST (EUT) INFORMATION .....	4
2.3. EUT'S TECHNICAL SPECIFICATIONS.....	5
2.3.1. LIST OF EUT'S PORTS .....	6
2.4. ANCILLARY EQUIPMENT .....	6
2.5. TEST ARRANGEMENT .....	7
<b>EXHIBIT 3. EUT OPERATING CONDITIONS AND CONFIGURATIONS DURING TESTS</b> .....	<b>8</b>
3.1. CLIMATE TEST CONDITIONS.....	8
3.2. OPERATIONAL TEST CONDITIONS & ARRANGEMENT FOR TEST SIGNALS .....	8
<b>EXHIBIT 4. SUMMARY OF TEST RESULTS</b> .....	<b>9</b>
4.1. LOCATION OF TESTS .....	9
4.2. APPLICABILITY & SUMMARY OF EMISSION TEST RESULTS .....	9
4.3. MODIFICATIONS INCORPORATED IN THE EUT FOR COMPLIANCE PURPOSES .....	9
4.4. DEVIATION OF STANDARD TEST PROCEDURES.....	9
<b>EXHIBIT 5. MEASUREMENTS, EXAMINATIONS &amp; TEST DATA FOR EMC EMISSIONS</b> .....	<b>10</b>
5.1. TEST PROCEDURES.....	10
5.2. MEASUREMENT UNCERTAINTIES .....	10
5.3. MEASUREMENT EQUIPMENT USED.....	10
5.4. ESSENTIAL/PRIMARY FUNCTIONS AS DECLARED BY THE MANUFACTURER.....	10
5.5. RF POWER OUTPUT [§§ 2.1046, 90.205 AND 22.535(A)&(F)] .....	11
5.5.1. Limits.....	11
5.5.2. Method of Measurements.....	11
5.5.3. Test Equipment List .....	11
5.5.4. Test Arrangement .....	11
5.5.5. Test Data .....	12
5.6. FREQUENCY STABILITY [§ 2.1055 AND 22.355].....	13
5.6.1. Limits.....	13
5.6.2. Method of Measurements.....	13
5.6.3. Test Equipment List .....	13
5.6.4. Test Arrangement .....	13
5.6.5. Test Data .....	14
5.7. AUDIO FREQUENCY RESPONSE [§ 2.1047(A)].....	15
5.7.1. Limits.....	15
5.7.2. Method of Measurements.....	15
5.7.3. Test Equipment List .....	15
5.7.4. Test Arrangement .....	15
5.7.5. Test Data .....	16
5.8. MODULATION LIMITING [§§ 2.1047(B) AND 22 (SUBPART E).210] .....	18
5.8.1. Limits.....	18
5.8.2. Method of Measurements.....	18

5.8.3. *Test Equipment List* ..... 18  
5.8.4. *Test Arrangement* ..... 18  
5.8.5. *Test Data* ..... 19  
5.9. RF EXPOSURE REQUIREMENT [§§ 1.1310 & 2.1091]..... 21  
5.9.1. *Method of Measurements*..... 21  
5.9.2. *Test Data* ..... 23  
5.10. 26 DB OCCUPIED BANDWIDTH [§ 2.1049]..... 24  
5.10.1. *Limits* ..... 24  
5.10.2. *Test Equipment List* ..... 24  
5.10.3. *Test Arrangement* ..... 24  
5.10.4. *Test Data* ..... 25  
5.11. BAND-EDGE AND OUT-OF-EMISSIONS [§ 2.1057, 2.1053 & 22.359(A)]..... 46  
5.11.1. *Limits* ..... 46  
5.11.2. *Method of Measurements*..... 46  
5.11.3. *Test Equipment List* ..... 46  
5.11.4. *Test Arrangement* ..... 46  
5.11.5. *Test Data* ..... 47  
5.12. TRANSMITTER SPURIOUS/HARMONIC RADIATED EMISSIONS [§ 2.1057, 2.1053 & 22.359(A)]..... 72  
5.12.1. *Limits* ..... 72  
5.12.2. *Method of Measurements*..... 72  
5.12.3. *Test Equipment List* ..... 72  
5.12.4. *Test Data* ..... 72  
**EXHIBIT 6. MEASUREMENT UNCERTAINTY..... 73**  
6.1. RADIATED EMISSION MEASUREMENT UNCERTAINTY..... 73  
**EXHIBIT 7. MEASUREMENT METHODS..... 74**  
7.1. CONDUCTED POWER MEASUREMENTS ..... 74  
7.2. RADIATED POWER MEASUREMENTS (ERP & EIRP) USING SUBSTITUTION METHOD ..... 75  
7.2.1. *Maximizing RF Emission Level (E-Field)* ..... 75  
7.2.2. *Measuring the EIRP of Spurious/Harmonic Emissions using Substitution Method*..... 76  
7.3. SPURIOUS EMISSIONS (CONDUCTED)..... 78

## EXHIBIT 1. INTRODUCTION

### 1.1. SCOPE

Reference:	FCC Parts 2 and 22 (Subpart E)
Title:	Code of Federal Regulations (CFR) Title 47 Telecommunication, Parts 2 and 22 (Subpart E)
Purpose of Test:	To obtain FCC Equipment Authorization for Radio operating in the frequency bands 931.0125 - 931.9875 MHz.
Test Procedures:	Both conducted and radiated emissions measurements were conducted in accordance with American National Standards Institute ANSI C63.4 - American National Standard for Methods of Measurement of Radio-Noise Emissions from Low-Voltage Electrical and Electronic Equipment in the Range of 9 kHz to 40 GHz.

### 1.2. RELATED SUBMITTAL(S)/GRANT(S)

None

### 1.3. NORMATIVE REFERENCES

Publication	Year	Title
FCC CFR Parts 0-19, 22-End	2007	Code of Federal Regulations – Telecommunication
ANSI C63.4	2003	American National Standard for Methods of Measurement of Radio-Noise Emissions from Low-Voltage Electrical and Electronic Equipment in the Range of 9 kHz to 40 GHz
CISPR 16-1-1	2004	Specification for Radio Disturbance and Immunity measuring apparatus and methods
TIA/EIA 603, Edition C	2004	Land Mobile FM or PM Communications Equipment Measurement and Performance Standards

## EXHIBIT 2. PERFORMANCE ASSESSMENT

### 2.1. CLIENT INFORMATION

APPLICANT	
Name:	Futurecom Systems Group Inc.
Address:	3277 Langstaff Road Concord, Ontario Canada L4K 5P8
Contact Person:	Mr. Tony Bombera Phone #: 905-660-5548 Fax #: 905-660-1380 Email Address: tonyb@futurecom.com

MANUFACTURER	
Name:	Futurecom Systems Group Inc.
Address:	3277 Langstaff Road Concord, Ontario Canada L4K 5P8
Contact Person:	Mr. Tony Bombera Phone #: 905-660-5548 Fax #: 905-660-1380 Email Address: tonyb@futurecom.com

### 2.2. EQUIPMENT UNDER TEST (EUT) INFORMATION

The following information (with the exception of the Date of Receipt) has been supplied by the applicant.

Brand Name:	Futurecom Systems Group Inc.
Product Name:	PAGING ON-CHANNEL REPEATER (OCR)
Model Name or Number:	OCR 900P
Serial Number:	Test samples
Type of Equipment:	Non-broadcast Radio Communication Equipment
Power Supply Requirement:	27.6 V DC
Transmitting/Receiving Antenna Type:	Non-integral
Operational Description:	The OCR 900P receives RF signals from a donor site. It re-transmits amplified RF signals on the same RF frequency.

### 2.3. EUT'S TECHNICAL SPECIFICATIONS

<b>Transmitter/Repeater</b>	
Equipment Type:	Fixed Base Station
Intended Operating Environment:	[ x ] Commercial [ x ] Light Industry & Heavy Industry
Power Supply Requirement:	27.6 V DC
RF Output Power Rating:	1 to 20.4 Watts (Variable)
Operating Frequency Range:	931.0125 - 931.9875 MHz
RF Output Impedance:	50 Ohms
Channel Spacing:	25 kHz
Type Of Modulation:	F3E, F2D (FFSK), F1D (FLEX) and F1D (POCSAG)
Occupied Bandwidth (99%):	15,7 KHz (F3E), 19.6 kHz (F2D), 15.3 kHz (F1D), 12.32 kHz (F1D)
Emission Designation*:	16K0F3E, 19K6F2D (FFSK), 15K3F1D (FLEX) & 12K3F1D (POCSAG)
Antenna Connector Type:	SMA female

\* For an average case of commercial telephony, the Necessary Bandwidth is calculated as follows:

### 2.3.1. LIST OF EUT'S PORTS

Port Number	EUT's Port Description	Number of Identical Ports	Connector Type	Cable Type (Shielded/Non-shielded)
1	Transmitter	1	SMA	Terminated with 50 Ohm load
2	Receiver	1	SMA	Terminated with 50 Ohm load
3	DC Input/Control	1	96 pin DIN	Non-shielded
4	RS 232	1	8-Pin Mini Din	Shielded

### 2.4. ANCILLARY EQUIPMENT

The EUT was tested while connected to the following representative configuration of ancillary equipment necessary to exercise the ports during tests:

None

## 2.5. TEST ARRANGEMENT

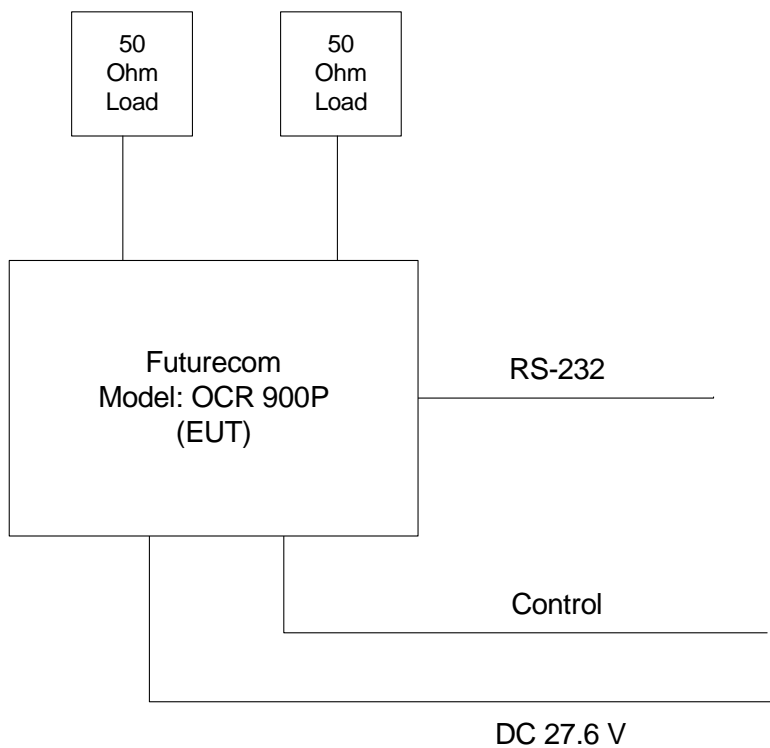



## EXHIBIT 3. EUT OPERATING CONDITIONS AND CONFIGURATIONS DURING TESTS

### 3.1. CLIMATE TEST CONDITIONS

The climate conditions of the test environment are as follows:

Temperature:	22°C
Humidity:	51%
Pressure:	102 kPa
Power input source:	27.6 V DC

### 3.2. OPERATIONAL TEST CONDITIONS & ARRANGEMENT FOR TEST SIGNALS

<b>Operating Modes:</b>	The transmitter was operated in a continuous transmission mode with the carrier modulated as specified in the Test Data.
<b>Special Test Software:</b>	Operating software provided by Futurecom for selecting operating channel frequency and power
<b>Special Hardware Used:</b>	N/A
<b>Transmitter Test Antenna:</b>	The EUT is tested with the transmitter antenna ports terminated to a 50 Ohms RF Load.

<b>Transmitter Test Signals</b>	
<b>Frequency Band(s):</b>	931.0125 - 931.9875 MHz
<b>Frequencies Tested:</b> (Near lowest, Centre and Highest frequency in each band of operation)	931.5 MHz
<b>RF Power Output (measured maximum output power):</b>	20 Watts High & 1 Watt Low
<b>Normal Test Modulation:</b>	Un-modulated, FM Voice (analog & digital)
<b>Modulating signal source:</b>	External

## EXHIBIT 4. SUMMARY OF TEST RESULTS

### 4.1. LOCATION OF TESTS

All of the measurements described in this report were performed at Ultratech Group of Labs located in the city of Oakville, Province of Ontario, Canada.

- Radiated Emissions were performed at the Ultratech's 10 TDK Semi-Anechoic Chamber situated in the Town of Oakville, province of Ontario. This test site been calibrated in accordance with ANSI C63.4, and found to be in compliance with the requirements of Sec. 2.948 of the FCC Rules. The descriptions and site measurement data of the Oakville 3-10 TDK Semi-Anechoic Chamber has been filed with FCC office (FCC File No.: 31040/SIT 1300B3) and Industry Canada office (Industry Canada File No.: IC2049A-3). Expiry Date of Site Calibration: May 17, 2009.

### 4.2. APPLICABILITY & SUMMARY OF EMISSION TEST RESULTS

FCC PARAGRAPH.	TEST REQUIREMENTS	APPLICABILITY (YES/NO)
22.535(a)&(f) & 2.1046	Effective radiated power	Yes
1.1307, 1.1310, 2.1091 & 2.1093	RF Exposure Limit	Yes
2.1055 & 22.355	Frequency Stability	Yes
2.1047(a)	Audio Frequency Response	Not applicable to new standard. However, tests are conducted under FCC's recommendation.
2.1047(b)	Modulation Limiting	Yes
2.1049	Occupied Bandwidth	Yes
2.1057 & 2.1051 & 22.359	Out-of-Band Emissions – Conducted Emissions at antenna port	Yes
2.1057 & 2.1053 & 22.359	Out-of-Band Emissions - Field Strength of Spurious Emissions	Yes
PAGING ON-CHANNEL REPEATER (OCR), Model No.: OCR 900P, by Futurecom Systems Group Inc. has been tested and found to comply with FCC Part 15, Subpart B - Radio Receivers and Class A Digital Devices. The engineering test report is kept in file and it is available upon request.		

**Note 1:** Not applicable for Repeater.

### 4.3. MODIFICATIONS INCORPORATED IN THE EUT FOR COMPLIANCE PURPOSES

None.

### 4.4. DEVIATION OF STANDARD TEST PROCEDURES

None.

---

---

## **EXHIBIT 5. MEASUREMENTS, EXAMINATIONS & TEST DATA FOR EMC EMISSIONS**

### **5.1. TEST PROCEDURES**

This section contains test results only. Details of test methods and procedures can be found in Exhibit 8 of this report.

### **5.2. MEASUREMENT UNCERTAINTIES**

The measurement uncertainties stated were calculated in accordance with requirements of UKAS Document NIS 81 with a confidence level of 95%. Please refer to Exhibit 7 for Measurement Uncertainties.

### **5.3. MEASUREMENT EQUIPMENT USED**

The measurement equipment used complied with the requirements of the Standards referenced in the Methods & Procedures ANSI C63.4 and CISPR 16 Series.

### **5.4. ESSENTIAL/PRIMARY FUNCTIONS AS DECLARED BY THE MANUFACTURER**

The essential function of the EUT is to correctly communicate data/voice to and from radios over RF link.

## 5.5. RF POWER OUTPUT [§§ 2.1046, 90.205 and 22.535(a)&(f)]

### 5.5.1. Limits

The effective radiated power (ERP) of transmitters operating on the channels listed in § 22.531 must not exceed the limits in this section.

**FCC § 22.535(a) – Transmitters:** *Maximum ERP* must not exceed 3,500 Watts in 931-932 MHz

**FCC § 22.535(f) - Signal boosters:-** The effective radiated power of signal boosters must not exceed 5 watts ERP under any normal operating condition.

### 5.5.2. Method of Measurements

Refer to Exhibit 7, Sections 7.1 (Conducted) and 7.2 (Radiated) of this report for measurement details

### 5.5.3. Test Equipment List

Test Instruments	Manufacturer	Model No.	Serial No.	Frequency Range
Attenuator(s)	Weinschel Corp	46-30-34 46-10-34	BM 5354 BS 4336	DC – 18 GHz DC – 18 GHz
Power Meter	Hewlett Packard	437B	3125406665	10 kHz – 50 GHz, sensor dependent
Power Sensor	Hewlett Packard	8481A	1150A15143	9 kHz – 26.5 GHz

### 5.5.4. Test Arrangement

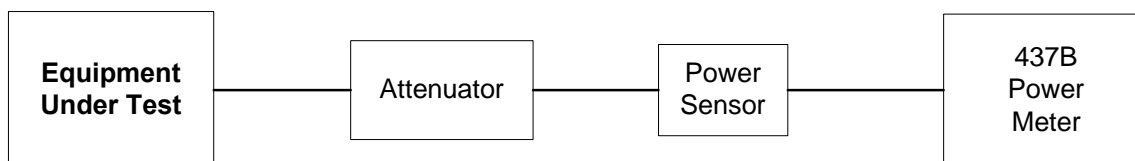

**5.5.5. Test Data**

Fundamental Frequency (MHz)	Power Setting Mode	Measured Conducted Power at Antenna Port (Watts)
<b>Test Mode: Repeater</b>		
931.5	Minimum	1.0
931.5	Maximum	20.4
<b>Test Mode: Transmitter Mode</b>		
931.5	Minimum	1.0
931.5	Maximum	20.2

**Remarks:**

- RF Power values recorded in the above table are conducted. For transmitter mode operation, the maximum allowable ERP power per FCC § 22.535(a) is 3,500 Watts, and for booster/repeater mode, the maximum allowable ERP power per FCC § 22.535(f) is 5 Watts.
- The antenna(s) used for this transmitter must be fixed mounted on permanent structures. RF exposure compliance is addressed at the time of licensing, as required by FCC Bureau(s), including antenna co-location requirements of FCC 1.1307(b)(3).

## 5.6. FREQUENCY STABILITY [§ 2.1055 and 22.355]

### 5.6.1. Limits

Except as otherwise provided in this part, the carrier frequency of each transmitter in the Public Mobile Services must be maintained within the tolerances given in Table C-1 of this section.

**TABLE C-1—FREQUENCY TOLERANCE FOR TRANSMITTERS IN THE PUBLIC MOBILE SERVICES**

Frequency range (MHz)	Base, fixed (ppm)	Mobile ≤3 watts (ppm)	Mobile ≤3 watts (ppm)
929 to 960	1.5	n/a	n/a

### 5.6.2. Method of Measurements

Refer to ULTRATECH Test Procedures, File # ULTR P001-2004 and Exhibit 8 of this report for measurement details.

### 5.6.3. Test Equipment List

Test Instruments	Manufacturer	Model No.	Serial No.	Frequency Range
Microwave Frequency Counter	EIP Microwave	545A	02683	10 Hz – 18 GHz
Attenuator(s)	Weinschel Corp	46-30-34 46-10-34	BM 5354 BS 4336	DC – 18 GHz DC – 18 GHz
Environmental Chamber	Envirotronics	SSH32C	119948475-11059	-60° to +177°C

### 5.6.4. Test Arrangement

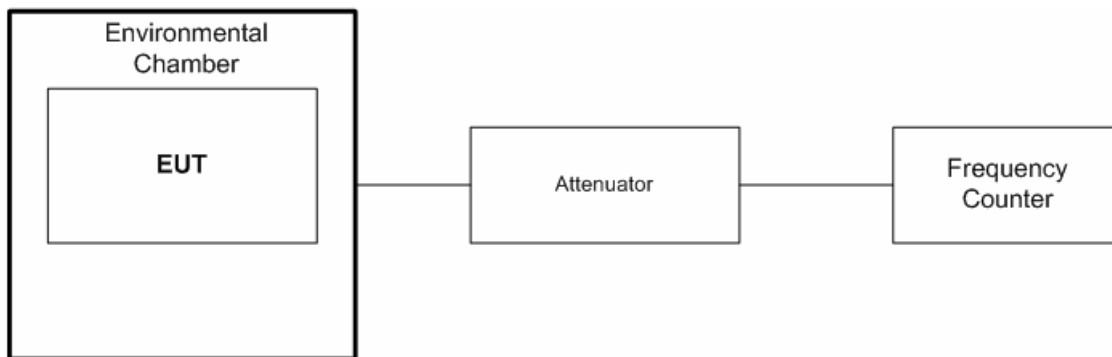

**5.6.5. Test Data**

<b>Product Name:</b>	PAGING ON-CHANNEL REPEATER (OCR)
<b>Model No.:</b>	OCR 900P
<b>Center Frequency:</b>	931 MHz
<b>Full Power Level:</b>	20 Watts (transmitter mode)
<b>Frequency Tolerance Limit:</b>	$\pm 1.5$ ppm or $\pm 620.7$ Hz
<b>Max. Frequency Tolerance Measured:</b>	+786 Hz or 0.844 ppm
<b>Input Voltage Rating:</b>	27.6 Vdc

Ambient Temperature (°C)	CENTER FREQUENCY & RF POWER OUTPUT VARIATION		
	Supply Voltage (Nominal) 27.6 Vdc	Supply Voltage (85% of Nominal) 23.46 Vdc	Supply Voltage (115% of Nominal) 31.74 Vdc
	Hz	Hz	Hz
-30	786	N/A	N/A
-20	685	N/A	N/A
-10	584	N/A	N/A
0	349	N/A	N/A
+10	234	N/A	N/A
+20	-74	90	90
+30	-54	N/A	N/A
+40	-46	N/A	N/A
+50	-133	N/A	N/A
+60	-260	N/A	N/A

## 5.7. AUDIO FREQUENCY RESPONSE [§ 2.1047(a)]

### 5.7.1. Limits

Recommended audio filter attenuation characteristics are given below:

RF Band MHz	Audio band	Minimum Attenuation Rel. to 1 kHz Attenuation
406.1 - 960	3 –20 kHz 20 – 30 kHz	$60 \log_{10}(f/3)$ dB where f is in kHz 50dB

### 5.7.2. Method of Measurements

The rated audio input signal was applied to the input of the audio low-pass filter (or of all modulation stages) using an audio oscillator, this input signal level and its corresponding output signal were then measured and recorded using the FFT (Audio) EMI Receiver. Tests were repeated at different audio signal frequencies from 0 to 50 kHz.

### 5.7.3. Test Equipment List

Test Instruments	Manufacturer	Model No.	Serial No.	Frequency Range
FFT (audio) EMI Receiver	Advantest	R9211E	82020336	10 mHz – 100 kHz, 1 MHz Input Impedance
AF Signal Generator	HP	8920B	US39064699	DC – 20 kHz
Attenuator(s)	Weinschel Corp	46-30-34 46-10-34	BM 5354 BS 4336	DC – 18 GHz DC – 18 GHz
Modulation Analyzer	HP	8901B	3226A04606	150 kHz – 1300 MHz

### 5.7.4. Test Arrangement

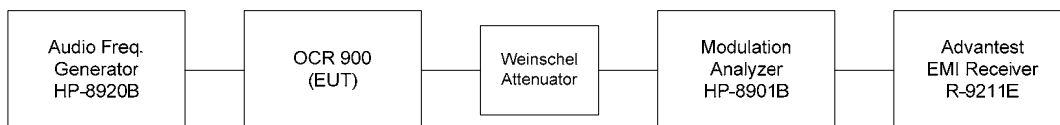



**5.7.5. Test Data**

**5.7.5.1. 12.5 kHz Channel Spacing, Frequency of All Modulation States**

FREQUENCY (kHz)	AUDIO IN (dBV)	AUDIO OUT (dBV)	ATTEN. (OUT - IN) (dB)	ATTEN. wrt. 1 kHz (dB)	Recommended Limit (dB)
0.10	-12.10	-70.00	-57.9	-66.8	--
0.20	-12.10	-58.76	-46.7	-55.5	--
0.40	-12.10	-11.16	0.9	-7.9	--
0.60	-12.10	-7.84	4.3	-4.6	--
0.80	-12.10	-5.10	7.0	-1.9	--
1.00	-12.10	-3.24	8.9	0.0	--
1.50	-12.10	0.05	12.2	3.3	--
2.00	-12.10	0.46	12.6	3.7	--
2.50	-12.10	0.48	12.6	3.7	--
3.00	-12.10	-0.56	11.5	2.7	0
3.50	-12.10	-1.65	10.5	1.6	-4
4.00	-12.10	-12.41	-0.3	-9.2	-7
4.50	-12.10	-64.21	-52.1	-61.0	-11
5.00	-12.10	-70.00	-57.9	-66.8	-13
6.00	-12.10	<-70.00	<-57.9	<-66.8	-18
7.00	-12.10	<-70.00	<-57.9	<-66.8	-22
8.00	-12.10	<-70.00	<-57.9	<-66.8	-26
9.00	-12.10	<-70.00	<-57.9	<-66.8	-29
10.00	-12.10	<-70.00	<-57.9	<-66.8	-31
12.00	-12.10	<-70.00	<-57.9	<-66.8	-36
14.00	-12.10	<-70.00	<-57.9	<-66.8	-40
16.00	-12.10	<-70.00	<-57.9	<-66.8	-44
18.00	-12.10	<-70.00	<-57.9	<-66.8	-47
20.00	-12.10	<-70.00	<-57.9	<-66.8	-49
22.00	-12.10	<-70.00	<-57.9	<-66.8	-50
25.00	-12.10	<-70.00	<-57.9	<-66.8	-50
30.00	-12.10	<-70.00	<-57.9	<-66.8	-50
35.00	-12.10	<-70.00	<-57.9	<-66.8	-50
40.00	-12.10	<-70.00	<-57.9	<-66.8	-50
45.00	-12.10	<-70.00	<-57.9	<-66.8	-50
50.00	-12.10	<-70.00	<-57.9	<-66.8	-50

Audio Frequency Response  
12.5 kHz Channel Spacing, Model: OCR 900

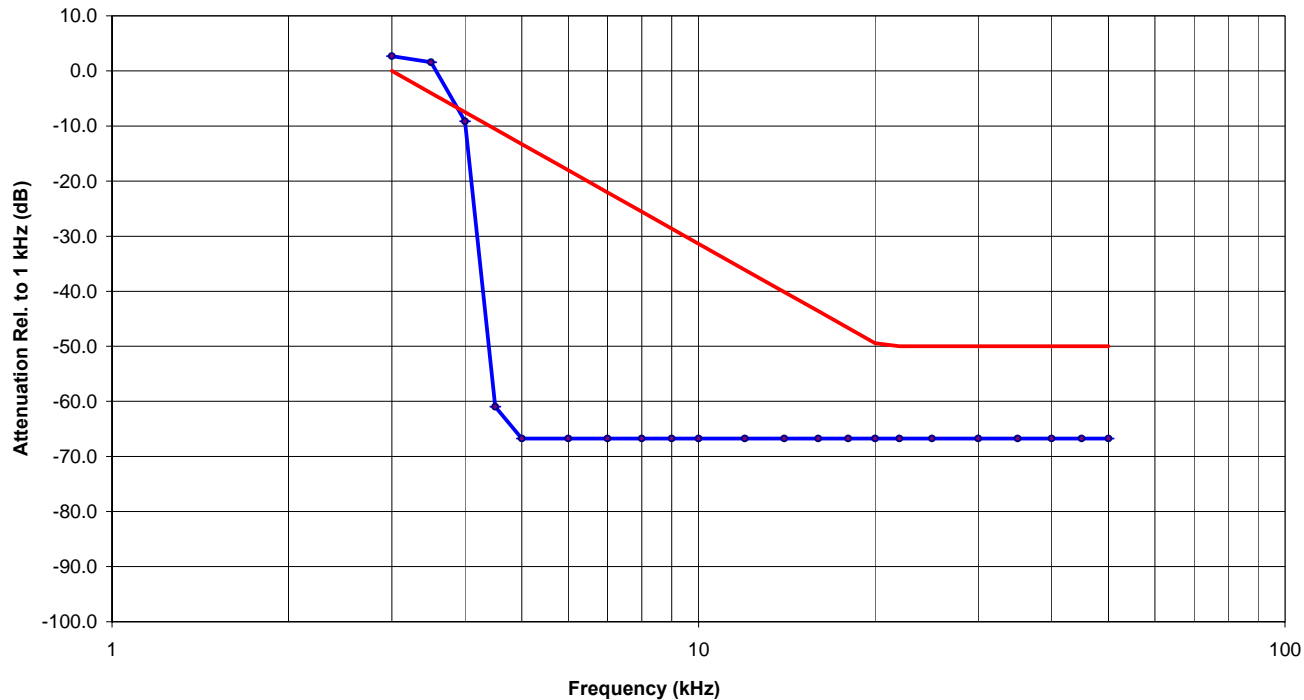

## 5.8. MODULATION LIMITING [§§ 2.1047(b) and 22 (Subpart E).210]

### 5.8.1. Limits

Recommended frequency deviation characteristics are given below:

- 2.5 kHz for 12.5 kHz Channel Spacing

### 5.8.2. Method of Measurements

Refer to ULTRATECH Test Procedures, File # ULTR P001-2004.

### 5.8.3. Test Equipment List

Test Instruments	Manufacturer	Model No.	Serial No.	Frequency Range
AF Signal Generator	HP	8920B	US39064699	DC – 20 kHz
Attenuator(s)	Weinschel Corp	46-30-34 46-10-34	BM 5354 BS 4336	DC – 18 GHz DC – 18 GHz
Modulation Analyzer	HP	8901B	3226A04606	150 kHz – 1300 MHz

### 5.8.4. Test Arrangement

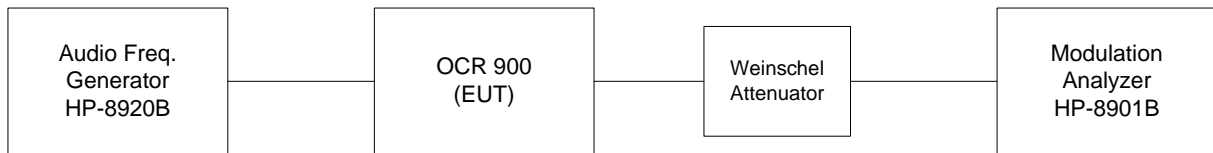

**5.8.5. Test Data**

**5.8.5.1. Voice Modulation Limiting for 12.5 kHz Channel Spacing Operation with High Power setting**

MODULATING SIGNAL LEVEL (mVrms)	PEAK FREQUENCY DEVIATION (kHz) at the following modulating frequency:					MAXIMUM LIMIT (kHz)
	0.1 kHz	0.5 kHz	1.0 kHz	3.0 kHz	5.0 kHz	
10	0.10	0.12	0.14	0.24	0.10	2.5
50	0.10	0.22	0.36	0.86	0.10	2.5
100	0.10	0.36	0.65	1.64	0.10	2.5
150	0.10	0.51	0.92	2.21	0.10	2.5
200	0.10	0.65	1.23	2.21	0.10	2.5
250	0.10	0.79	1.53	2.23	0.10	2.5
300	0.10	0.93	1.81	2.25	0.10	2.5
350	0.10	1.06	2.09	2.27	0.10	2.5
400	0.10	1.21	2.18	2.29	0.10	2.5
450	0.10	1.34	2.21	2.30	0.10	2.5
500	0.10	1.48	2.21	2.32	0.11	2.5
600	0.10	1.78	2.22	2.36	0.11	2.5
700	0.10	2.06	2.23	2.36	0.13	2.5
800	0.10	2.16	2.24	2.36	0.13	2.5
900	0.10	2.16	2.24	2.36	0.14	2.5
1000	0.10	2.16	2.24	2.36	0.14	2.5

Voice Signal Input Level = STD MOD Level + 16 dB  
 = 248 mVrms + 16 dB  
 = 47.89 dBmV + 16 dB  
 = 63.89 dBmV  
 = 1564.77 Vrms

MODULATING FREQUENCY (KHz)	PEAK FREQUENCY DEVIATION (KHz)	MAXIMUM LIMIT (KHz)
0.1	0.42	2.5
0.2	0.97	2.5
0.4	2.20	2.5
0.6	2.18	2.5
0.8	2.19	2.5
1.0	2.23	2.5
1.2	2.27	2.5
1.4	2.23	2.5
1.6	2.27	2.5
1.8	2.27	2.5
2.0	2.28	2.5
2.5	2.28	2.5
3.0	2.37	2.5
3.5	2.17	2.5
4.0	1.67	2.5
4.5	0.22	2.5
5.0	0.16	2.5
6.0	0.24	2.5
7.0	0.78	2.5
8.0	1.10	2.5
9.0	1.18	2.5
10.0	0.15	2.5

### 5.9. RF EXPOSURE REQUIREMENT [§§ 1.1310 & 2.1091]

The criteria listed in table 1 shall be used to evaluate the environmental impact of human exposure to radiofrequency (RF) radiation as specified in RSS-102

#### FCC 47 CFR 1.1310:

TABLE 1—LIMITS FOR MAXIMUM PERMISSIBLE EXPOSURE (MPE)				
Frequency range (MHz)	Electric field strength (V/m)	Magnetic field strength (A/m)	Power density (mW/cm <sup>2</sup> )	Averaging time (minutes)
<b>(A) Limits for Occupational/Controlled Exposures</b>				
0.3–3.0 .....	614	1.63	*(100)	6
3.0–30 .....	1842/f	4.89/f	*(900/f <sup>2</sup> )	6
30–300 .....	61.4	0.163	1.0	6
300–1500 .....	.....	.....	f/300	6
1500–100,000 .....	.....	.....	5	6
<b>(B) Limits for General Population/Uncontrolled Exposure</b>				
0.3–1.34 .....	614	1.63	*(100)	30
1.34–30 .....	824/f	2.19/f	*(180/f <sup>2</sup> )	30
30–300 .....	27.5	0.073	0.2	30
300–1500 .....	.....	.....	f/1500	30
1500–100,000 .....	.....	.....	1.0	30
f = frequency in MHz				
* = Plane-wave equivalent power density				
NOTE 1 TO TABLE 1: Occupational/controlled limits apply in situations in which persons are exposed as a consequence of their employment provided those persons are fully aware of the potential for exposure and can exercise control over their exposure. Limits for occupational/controlled exposure also apply in situations when an individual is transient through a location where occupational/controlled limits apply provided he or she is made aware of the potential for exposure.				
NOTE 2 TO TABLE 1: General population/uncontrolled exposures apply in situations in which the general public may be exposed, or in which persons that are exposed as a consequence of their employment may not be fully aware of the potential for exposure or can not exercise control over their exposure.				

#### 5.9.1. Method of Measurements

Refer to FCC @ 1.1310 and 2.1091

- In order to demonstrate compliance with MPE requirements (see Section 2.1091), the following information is typically needed:
  - (1) Calculation that estimates the minimum separation distance (20 cm or more) between an antenna and persons required to satisfy power density limits defined for free space.
  - (2) Antenna installation and device operating instructions for installers (professional/unskilled users), and the parties responsible for ensuring compliance with the RF exposure requirement.
  - (3) Any caution statements and/or warning labels that are necessary in order to comply with the exposure limits.
  - (4) Any other RF exposure related issues that may affect MPE compliance.

**Calculation Method of RF Safety Distance:**

$$S = PG/4\pi r^2 = EIRP/4\pi r^2$$

Where: P: power input to the antenna in mW  
EIRP: Equivalent (effective) isotropic radiated power.  
S: power density mW/cm<sup>2</sup>  
G: numeric gain of antenna relative to isotropic radiator  
r: distance to centre of radiation in cm

$$r = \sqrt{PG/4\pi S}$$

- For portable transmitters (see Section 2.1093), or devices designed to operate next to a person's body, compliance is determined with respect to the SAR limit (define in the body tissues) for near-field exposure conditions. If the maximum average output power, operating condition configurations and exposure conditions are comparable to those of existing cellular and PCS phones, SAR evaluation may be required in order to determine if such a device complies with SAR limit. When SAR evaluation data is not available, and the additional supporting information cannot assure compliance, the Commission may request that an SAR evaluation be performed, as provided for in Section 1.1307(d).

**5.9.2. Test Data**

**Antenna Gain Limit specified by Manufacturer: No Specific Gain Specified**

As an **Example** to show how to calculate MPE safe distance, antenna with a gain of 2.15 dBi is considered and calculations are as per below.

(1) Lowest Frequency (MHz)	Measured Peak RF Conducted Power (dBm)	Calculated EIRP (dBm)	Exposure Condition	Calculated Minimum RF Safety Distance r (cm)*
931.5 MHz	43.1	45.25	Occupational	29.3
931.5 MHz	43.1	45.25	Bystanders	65.5

\* The minimum separation distance between the antenna and bodies of users are calculated using the following formula:

RF EXPOSURE DISTANCE LIMITS:  $r = (PG/4\pi S)^{1/2} = (EIRP/4\pi S)^{1/2}$

Occupational/ Control Exposures:  $S = f/300 = 931.5 \text{ MHz}/300 \text{ mW/cm}^2$

For bystanders/ Uncontrolled Exposure:  $S = f/1500 = 931.5 \text{ MHz}/1500 \text{ mW/cm}^2$

Occupational:  $r = (EIRP/4\pi S)^{1/2} = (33,497/(4\pi(931.5 \text{ MHz}/300)))^{1/2} = 29.3 \text{ cm}$

For bystanders:  $r = (EIRP/4\pi S)^{1/2} = (33,497/(4\pi(931.5 \text{ MHz}/1500)))^{1/2} = 65.5 \text{ cm}$

<b>Evaluation of RF Exposure Compliance Requirements</b>	
<b>RF Exposure Requirements</b>	<b>Compliance with FCC Rules</b>
Minimum calculated separation distance between antenna and persons required:	Manufacturer' instruction for separation distance between antenna and persons required:  Will be determined by the User at time of antenna installation using the table 3 given in the User Manual.
Antenna installation and device operating instructions for installers (professional/unskilled users), and the parties responsible for ensuring compliance with the RF exposure requirement	Please refer to User's Manual for details.
Caution statements and/or warning labels that are necessary in order to comply with the exposure limits	Please refer to User's Manual for RF Exposure Information.
Any other RF exposure related issues that may affect MPE compliance	None.



## 5.10. 26 dB Occupied Bandwidth [§ 2.1049]

### 5.10.1. Limits

No Limit

### 5.10.2. Test Equipment List

Test Instruments	Manufacturer	Model No.	Serial No.	Frequency Range
Spectrum Analyzer	Advantest	R3271	15050203	100 Hz – 26.5 GHz
AF/RF Signal Generator	HP	8920B	US39064699	DC – 20 kHz
Attenuator(s)	Weinschel Corp	46-30-34 46-10-34	BM 5354 BS 4336	DC – 18 GHz DC – 18 GHz
Spectrum Analyzer	Rohde & Schwarz	FSEK 30	100077	20 Hz – 40 GHz

### 5.10.3. Test Arrangement

Repeater Test Setup:-



## 5.10.4. Test Data

### 5.10.4.1. 26 dB Occupied Bandwidth Measurements

Frequency (MHz)	Modulation	*Measured 26 dB BW of the RF Input Signal (kHz)	*Measured 26 dB BW of the RF Output Signal (kHz)
931.5	Analog Voice (F3E)	15.69	15.69
931.5	FFSK (F2D), Freq. Dev.: $\pm 1.5$ kHz	17.31	16.91
931.5	FFSK (F2D), Freq. Dev.: $\pm 3.0$ kHz	20.54	19.63
931.5	FLEX, 2-FSK 1600bps (F1D), Freq. Dev.: $\pm 4.8$ kHz	14.85	14.85
931.5	FLEX, 2-FSK 3200bps (F1D), Freq. Dev.: $\pm 4.8$ kHz	14.91	14.73
931.5	FLEX, 4-FSK 3200bps (F1D), Freq. Dev.: $\pm 4.8$ kHz	16.41	15.31
931.5	FLEX, 4-FSK 6400bps (F1D), Freq. Dev.: $\pm 4.8$ kHz	19.48	15.31
931.5	POCSAG 512 baud rate (F1D), Freq. Dev.: $\pm 3.0$ kHz	9.5	9.06
931.5	POCSAG 1200 baud rate (F1D), Freq. Dev.: $\pm 3.0$ kHz	10.34	10.34
931.5	POCSAG 2400 baud rate (F1D), Freq. Dev.: $\pm 3.0$ kHz	12.38	12.32

\* Refer to the following test data plots, Plots # 1(a)&(b) through 10(a)&(b), for details.

**PLOT # 1(a): 26 dB Occupied Bandwidth – RF Input Signal**  
**Centre Frequency: 931.5 MHz, Input Power: maximum**  
**Modulation: FM modulation with 2.5 kHz sine wave signal (F3E)**

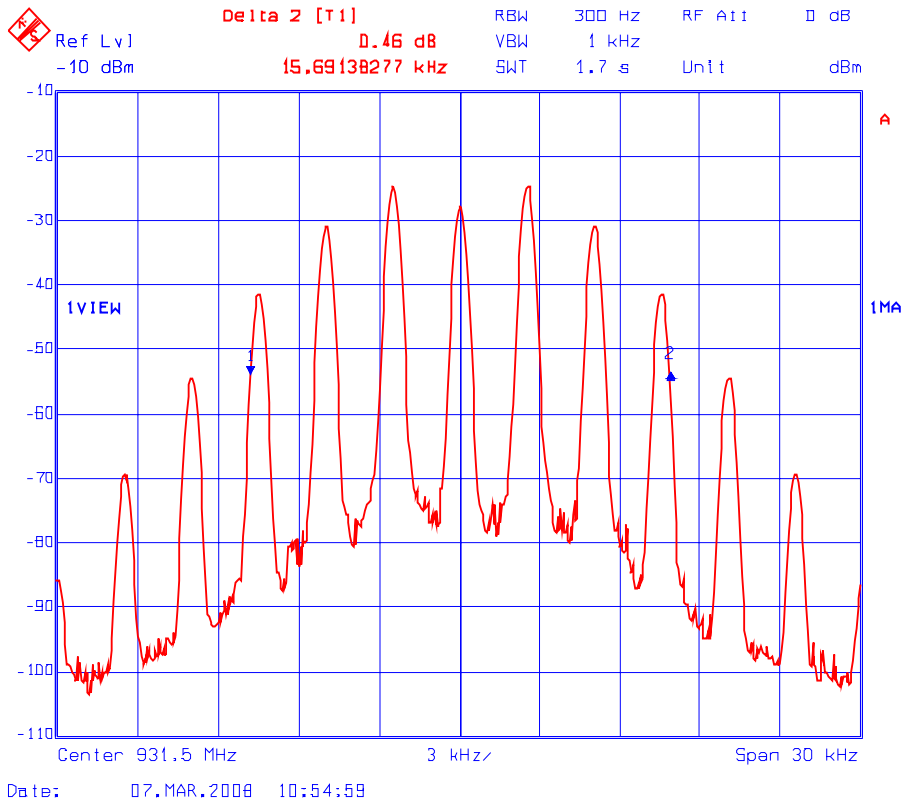

**PLOT # 1(b): 26 dB Occupied Bandwidth – RF Output Signal**  
**Centre Frequency: 931.5 MHz, Output Power: maximum**  
**Modulation: FM modulation with 2.5 kHz sine wave signal (F3E)**

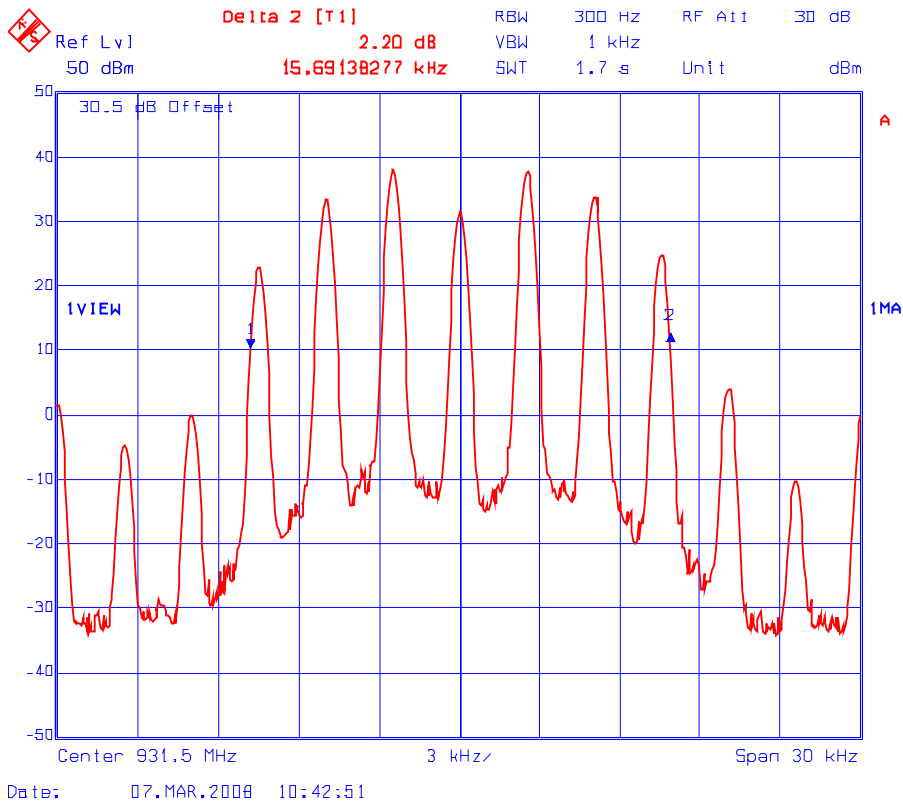

**PLOT # 2(a) 26 dB Occupied Bandwidth – RF Input Signal**  
**Centre Frequency: 931.5 MHz, Input Power: maximum**  
**Modulation: FFSK (F2D), Freq. Deviation =  $\pm 1.5$  kHz**

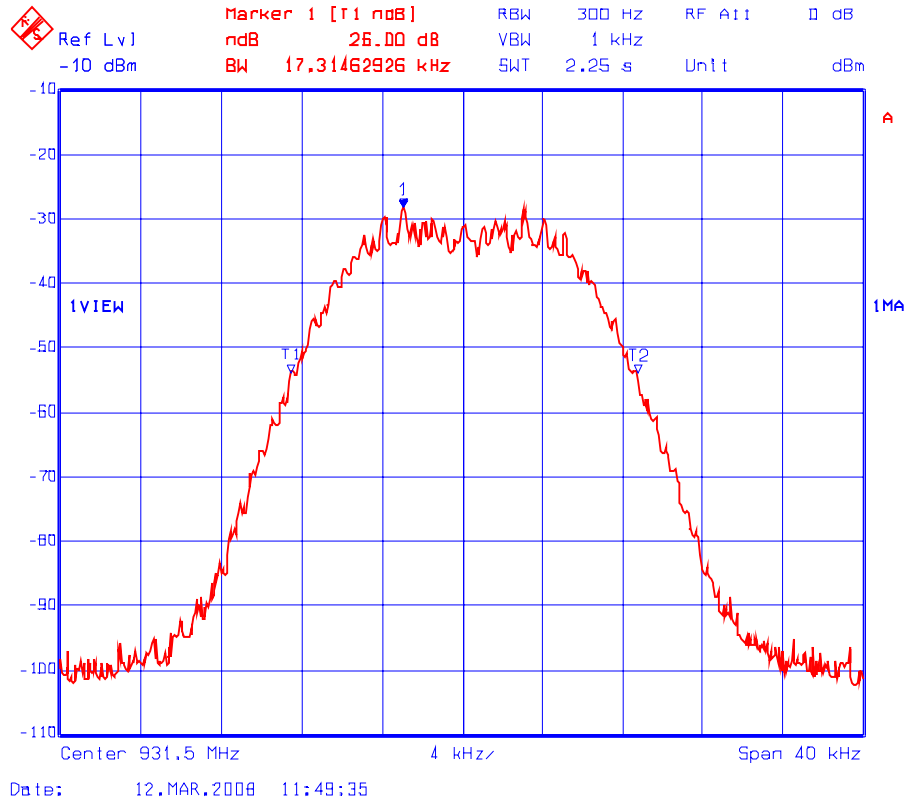

**PLOT # 2(b): 26 dB Occupied Bandwidth – RF Output Signal**  
**Centre Frequency: 931.5 MHz, Output Power: maximum**  
**Modulation: FFSK (F2D), Freq. Deviation =  $\pm 1.5$  kHz**

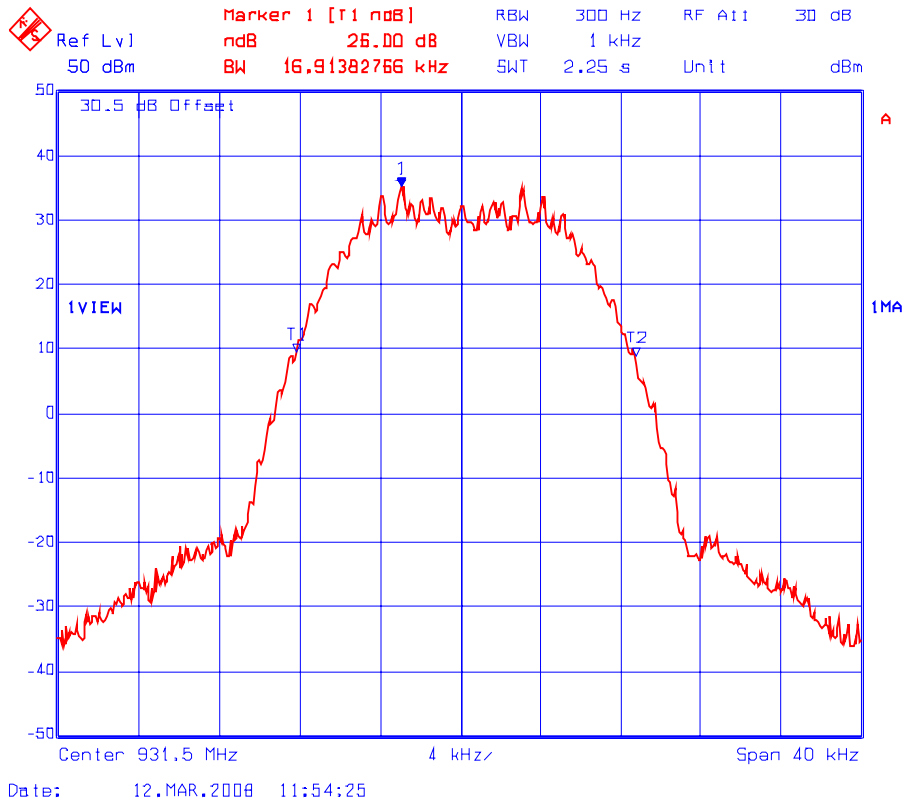

**PLOT # 3(a): 26 dB Occupied Bandwidth – RF Input Signal**  
**Centre Frequency: 931.5 MHz, Input Power: maximum**  
**Modulation: FFSK (F2D), Freq. Deviation = 3 kHz**

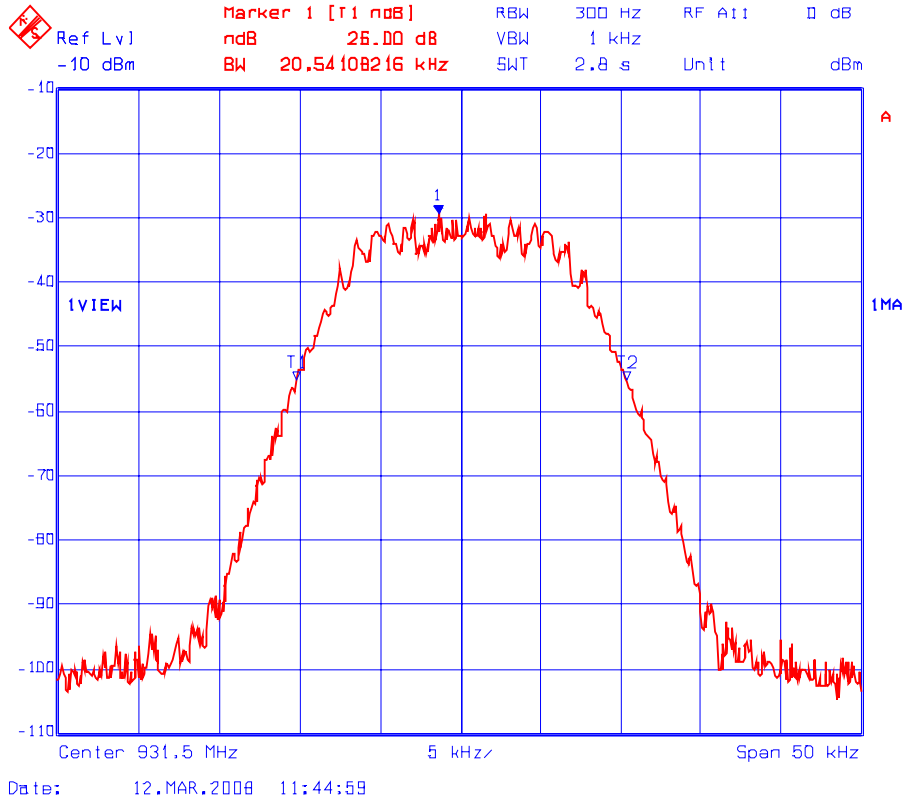

**PLOT # 3(b): 26 dB Occupied Bandwidth – RF Output Signal**  
**Centre Frequency: 931.5 MHz, Output Power: maximum**  
**Modulation: FFSK (F2D), Freq. Deviation =  $\pm 3$  kHz**

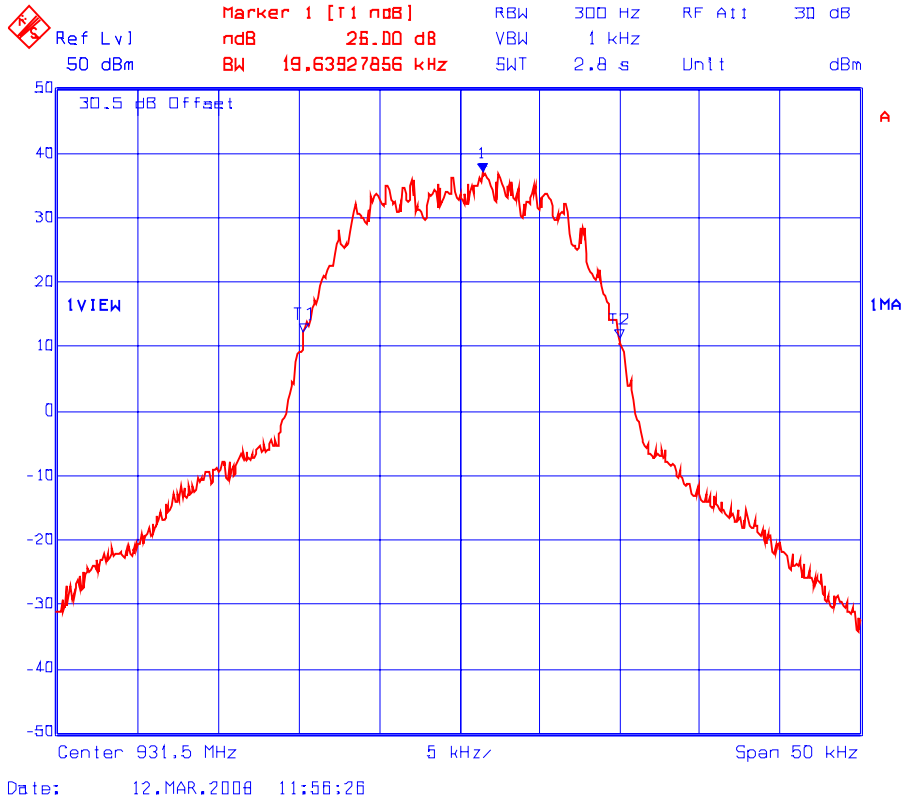



**PLOT # 4(a): 26 dB Occupied Bandwidth – RF Input Signal**  
**Centre Frequency: 931.5 MHz, Input Power: maximum**  
**Modulation: FLEX, 2-FSK (F1D), Data Rate: 1600 bps, Freq. Deviation =  $\pm 4.8$  kHz**

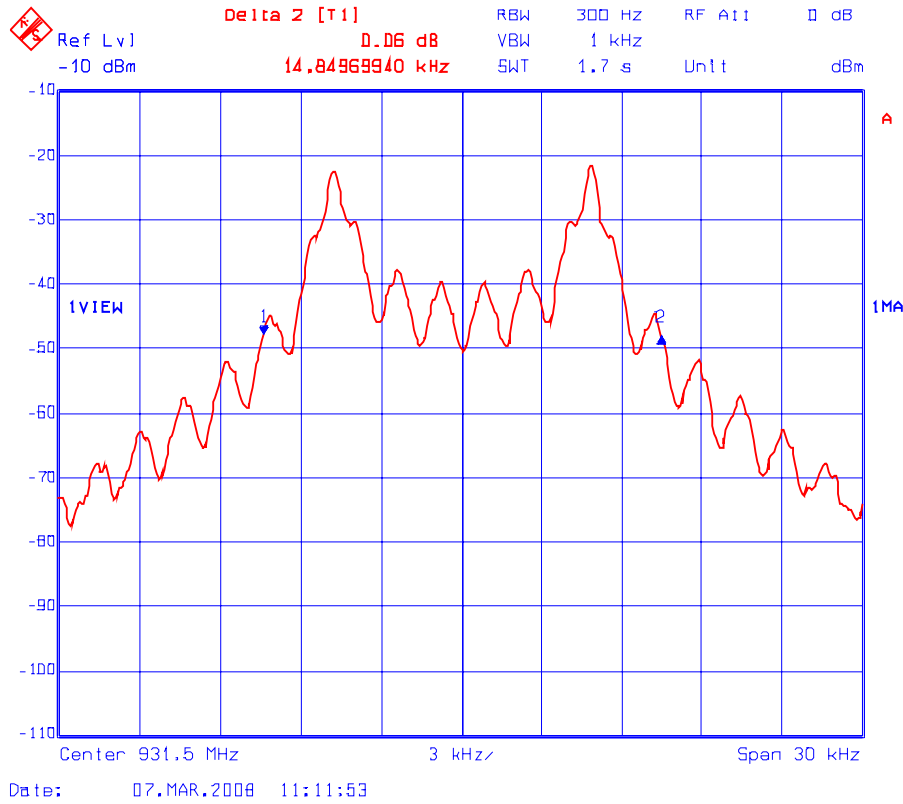

**PLOT # 4(b): 26 dB Occupied Bandwidth – RF Output Signal**  
**Centre Frequency: 931.5 MHz, Output Power: maximum**  
**Modulation: FLEX, 2-FSK (F1D), Data Rate: 1600 bps, Freq. Deviation =  $\pm 4.8$  kHz**

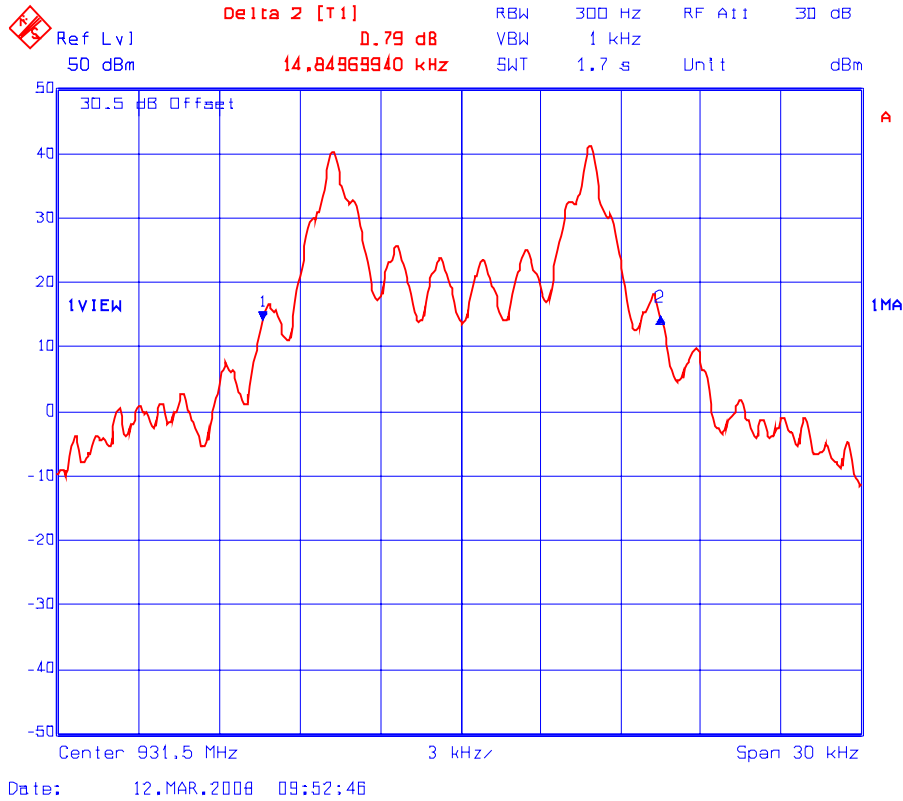

**PLOT # 5(a): 26 dB Occupied Bandwidth – RF Input Signal**  
**Centre Frequency: 931.5 MHz, Input Power: maximum**  
**Modulation: FLEX, 2-FSK (F1D), Data Rate: 3200 bps, Freq. Deviation =  $\pm 4.8$  kHz**

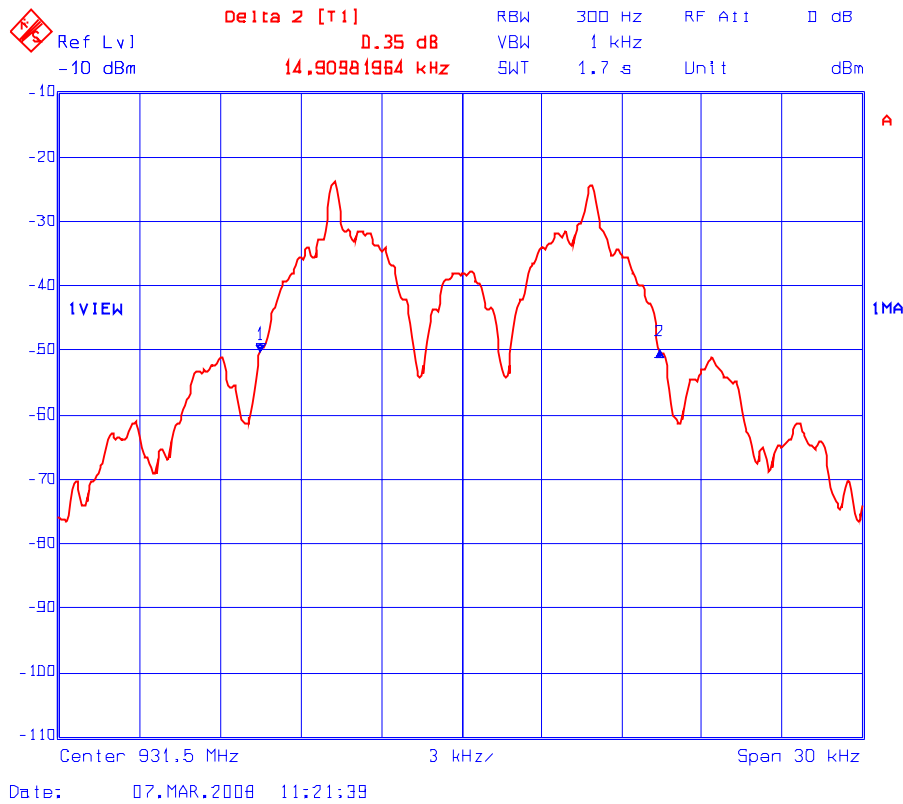

**PLOT # 5(b): 26 dB Occupied Bandwidth – RF Output Signal**  
**Centre Frequency: 931.5 MHz, Output Power: maximum**  
**Modulation: FLEX, 2-FSK (F1D), Data Rate: 3200 bps, Freq. Deviation =  $\pm 4.8$  kHz**

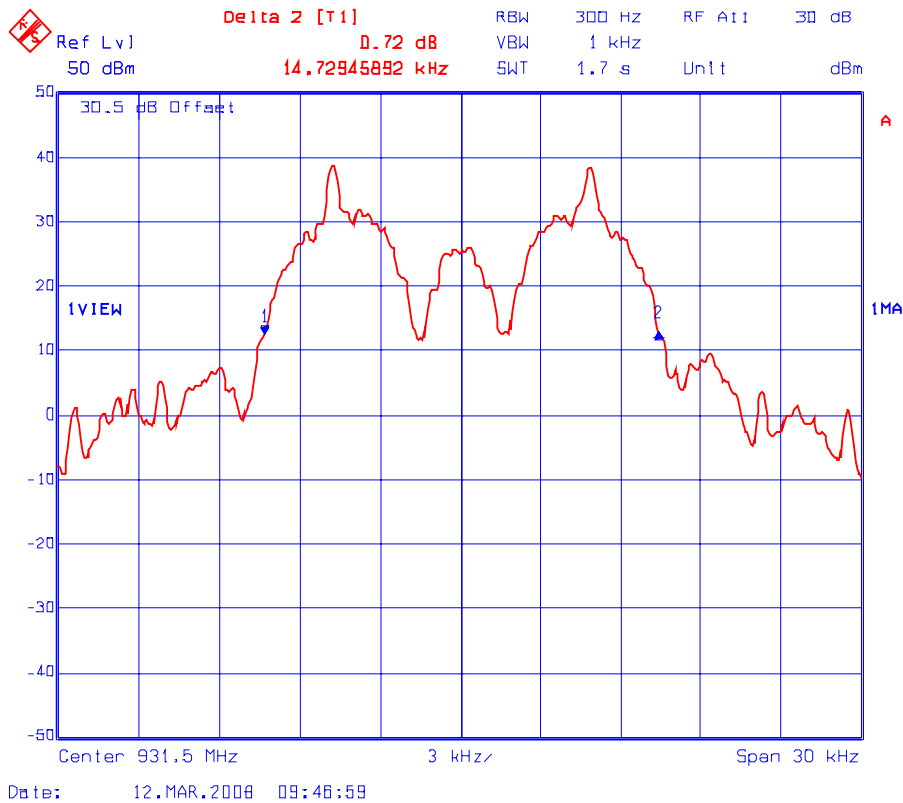

**PLOT # 6(a): 26 dB Occupied Bandwidth – RF Input Signal**  
**Centre Frequency: 931.5 MHz, Input Power: maximum**  
**Modulation: FLEX, 4-FSK (F1D), Data Rate: 3200 bps, Freq. Deviation =  $\pm 4.8$  kHz**

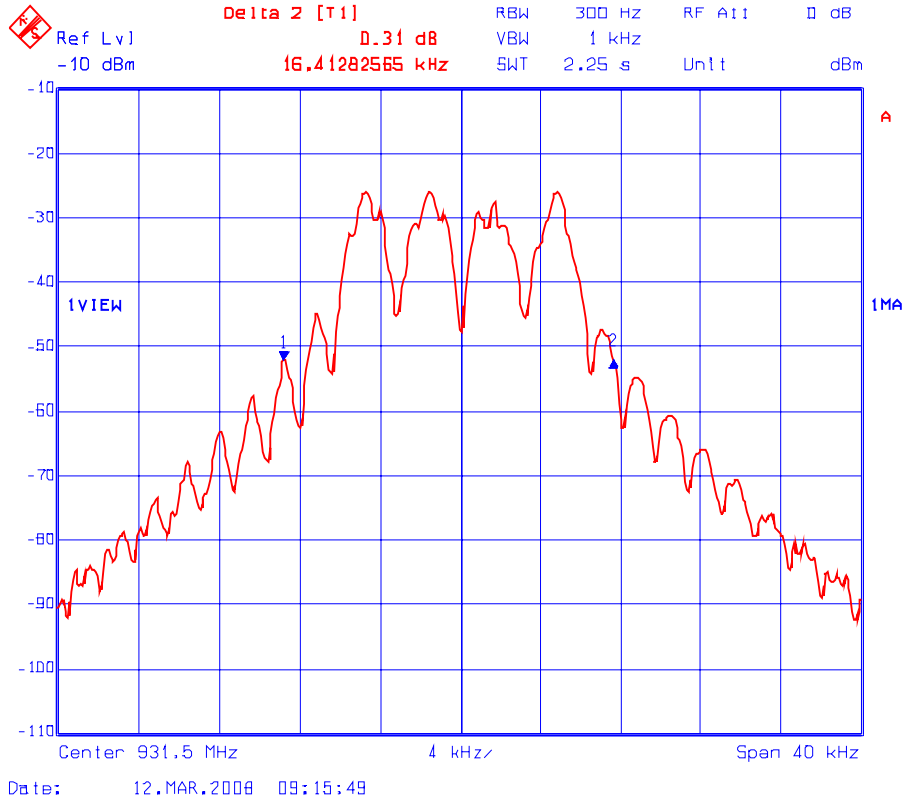

**PLOT # 6(b): 26 dB Occupied Bandwidth – RF Output Signal**  
**Centre Frequency: 931.5 MHz, Output Power: maximum**  
**Modulation: FLEX, 4-FSK (F1D), Data Rate: 3200 bps, Freq. Deviation =  $\pm 4.8$  kHz**

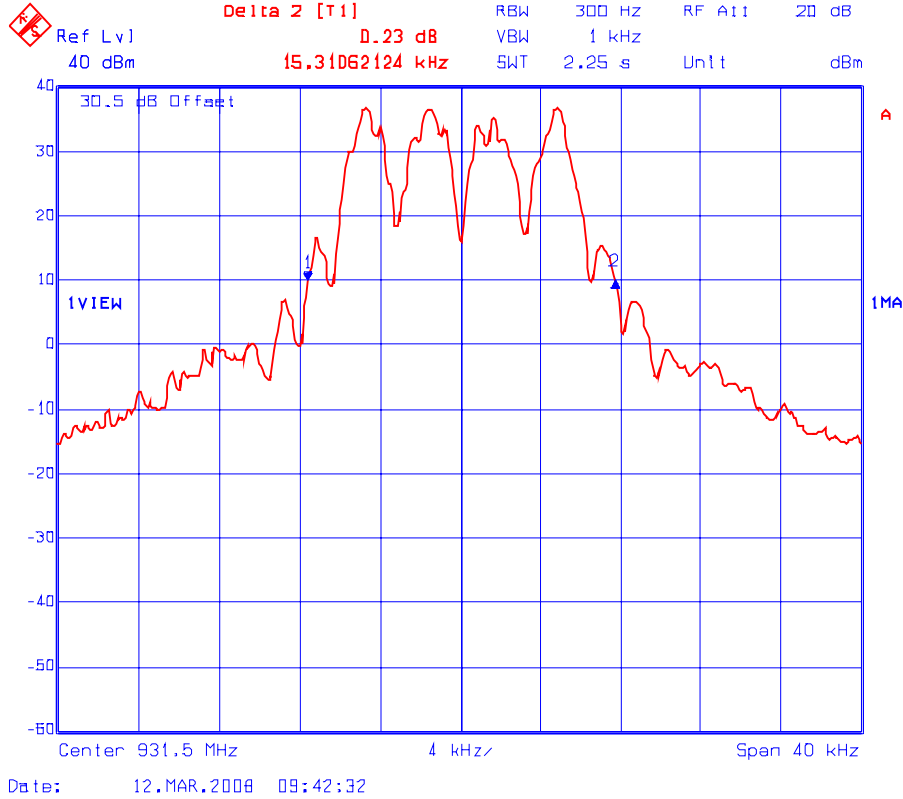

**PLOT # 7(a): 26 dB Occupied Bandwidth – RF Input Signal**  
**Centre Frequency: 931.5 MHz, Input Power: maximum**  
**Modulation: FLEX, 4-FSK (F1D), Data Rate: 6400 bps, Freq. Deviation =  $\pm 4.8$  kHz**

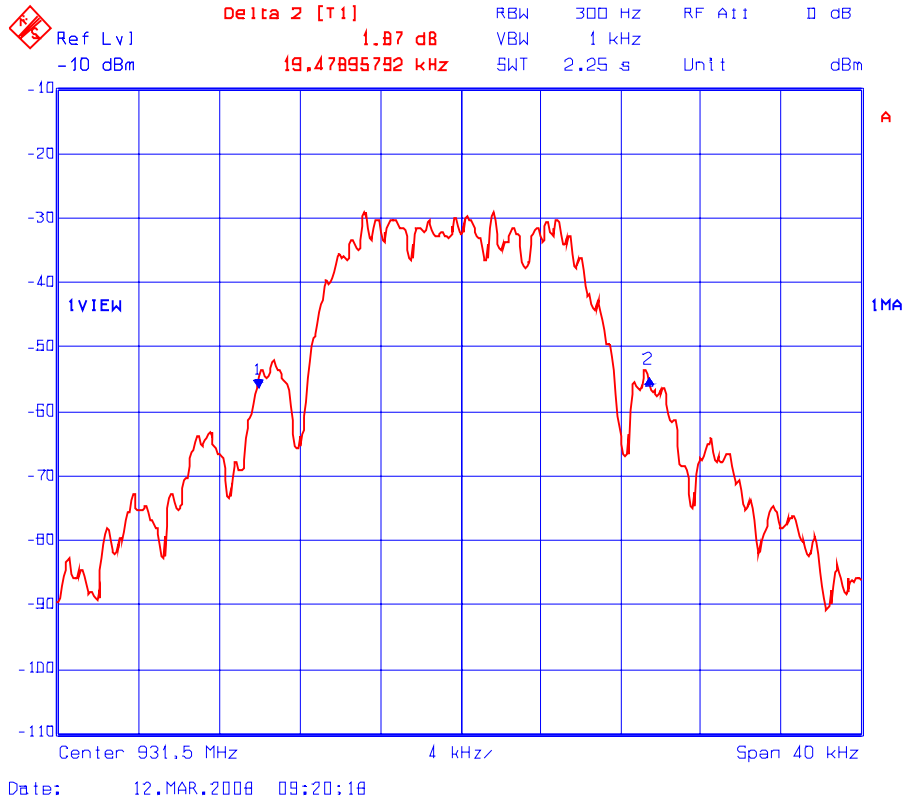

**PLOT # 7(b): 26 dB Occupied Bandwidth – RF Output Signal**  
**Centre Frequency: 931.5 MHz, Output Power: maximum**  
**Modulation: FLEX, 4-FSK (F1D), Data Rate: 6400 bps, Freq. Deviation =  $\pm 4.8$  kHz**

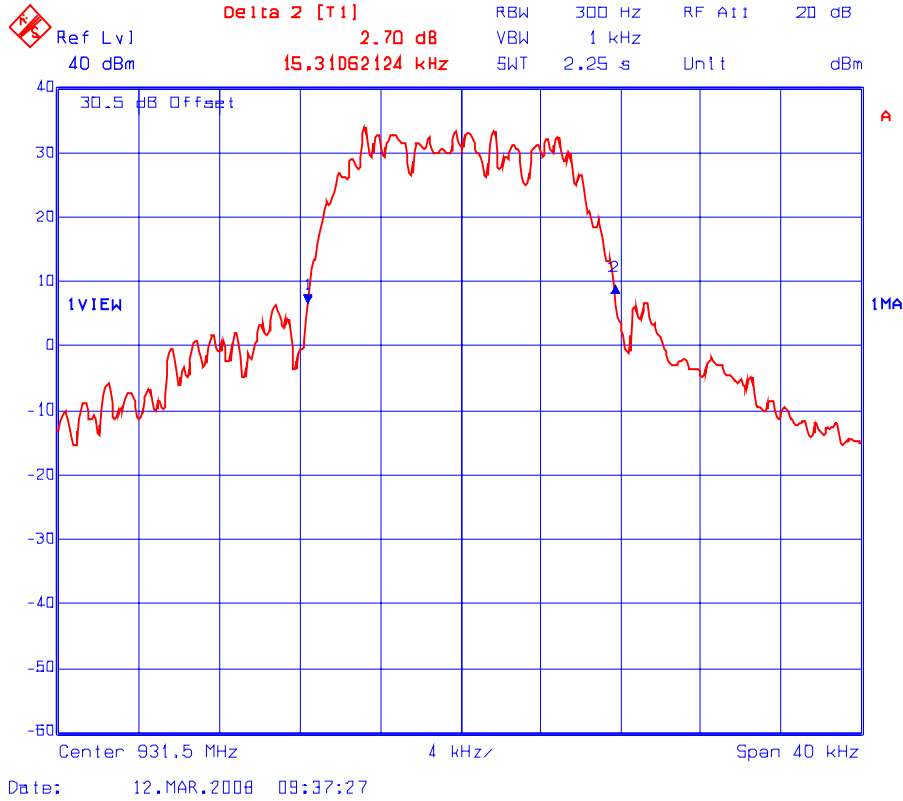



**PLOT # 8(a): 26 dB Occupied Bandwidth – RF Input Signal**  
**Centre Frequency: 931.5 MHz, Input Power: maximum**  
**Modulation: POCsAG (F1D), Data Rate: 512 baud, Freq. Deviation =  $\pm 3$  kHz (tone)**

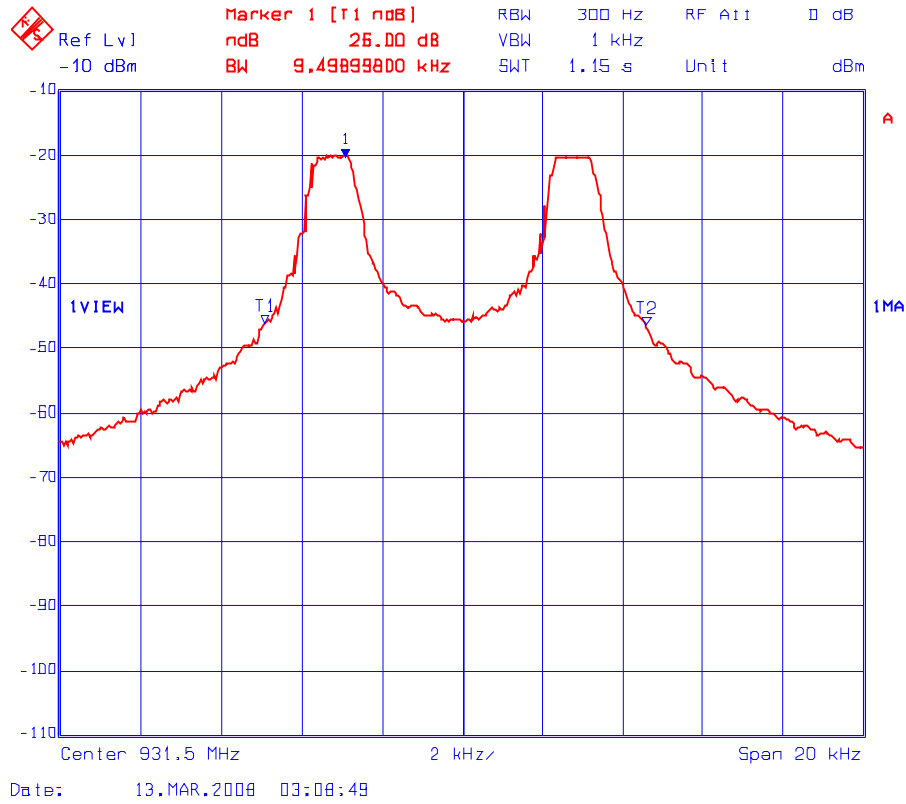

**PLOT # 8(b): 26 dB Occupied Bandwidth – RF Output Signal**  
**Centre Frequency: 931.5 MHz, Output Power: maximum**  
**Modulation: POCSAG (F1D), Data Rate: 512 baud, Freq. Deviation =  $\pm 3$  kHz (tone)**

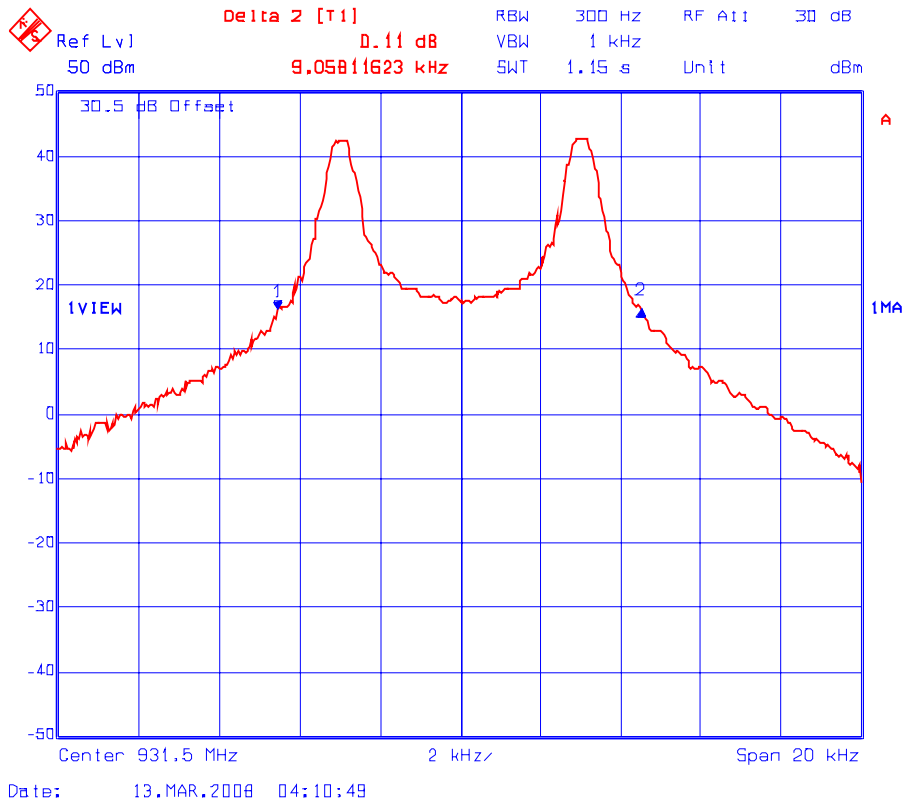

**PLOT # 9(a): 26 dB Occupied Bandwidth – RF Input Signal**  
**Centre Frequency: 931.5 MHz, Input Power: maximum**  
**Modulation: POCSAG (F1D), Data Rate: 1200 baud, Freq. Deviation =  $\pm 3$  kHz (tone)**

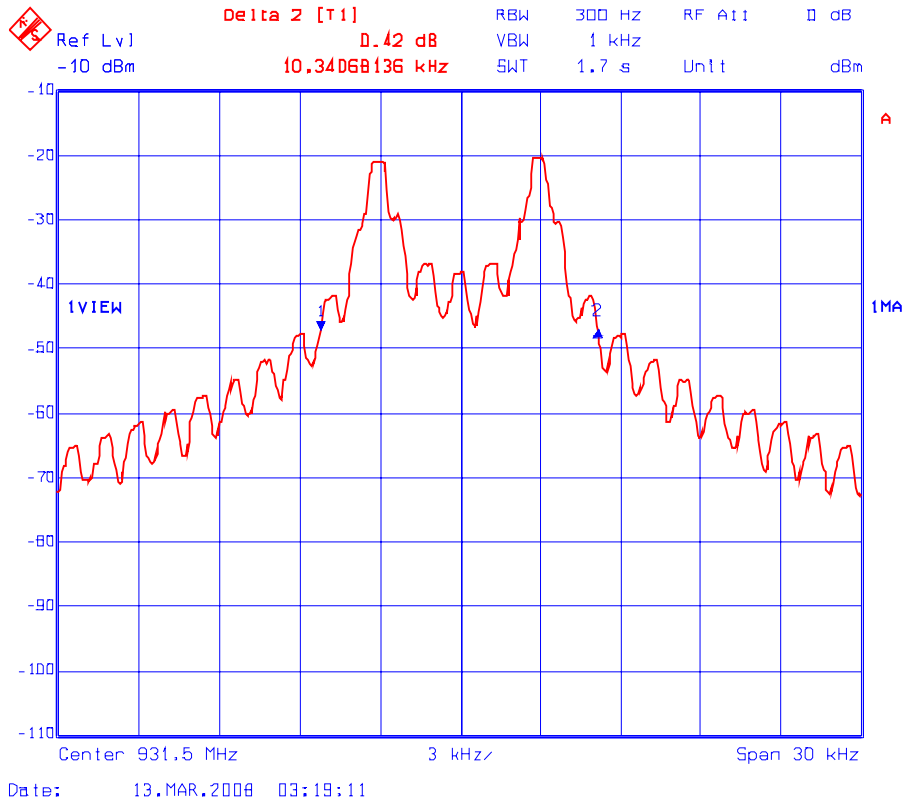

**PLOT # 9(b): 26 dB Occupied Bandwidth – RF Output Signal**  
**Centre Frequency: 931.5 MHz, Output Power: maximum**  
**Modulation: POCSAG (F1D), Data Rate: 1200 baud, Freq. Deviation =  $\pm 3$  kHz (tone)**

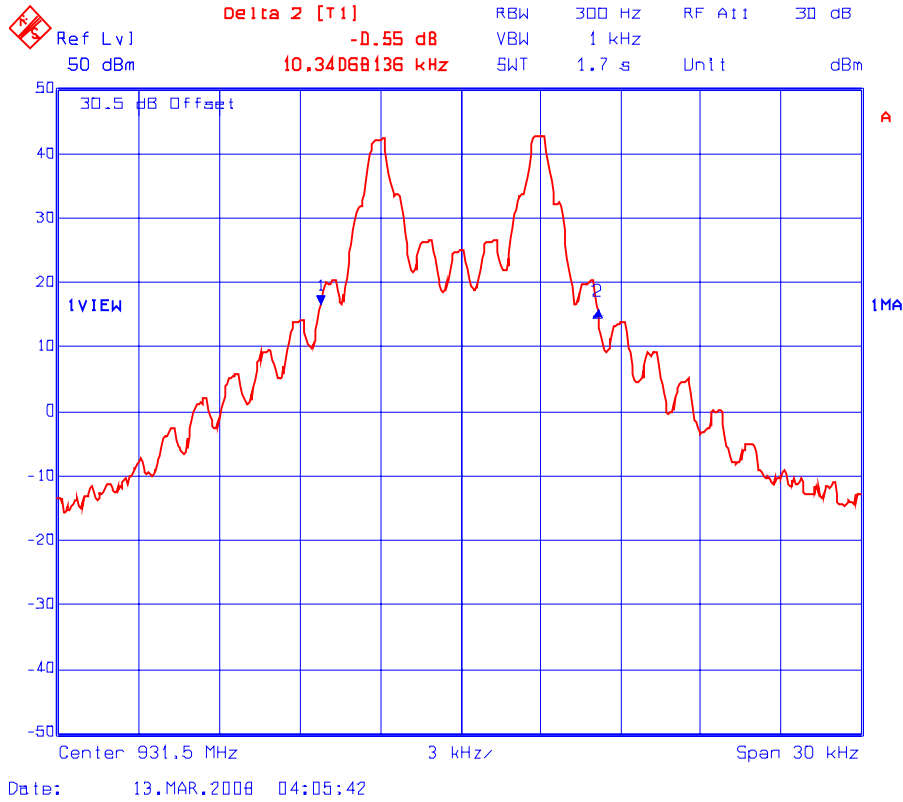

**PLOT # 10(a): 26 dB Occupied Bandwidth – RF Input Signal**  
**Centre Frequency: 931.5 MHz, Input Power: maximum**  
**Modulation: POCSAG (F1D), Data Rate: 2400 baud, Freq. Deviation =  $\pm 3$  kHz (tone)**

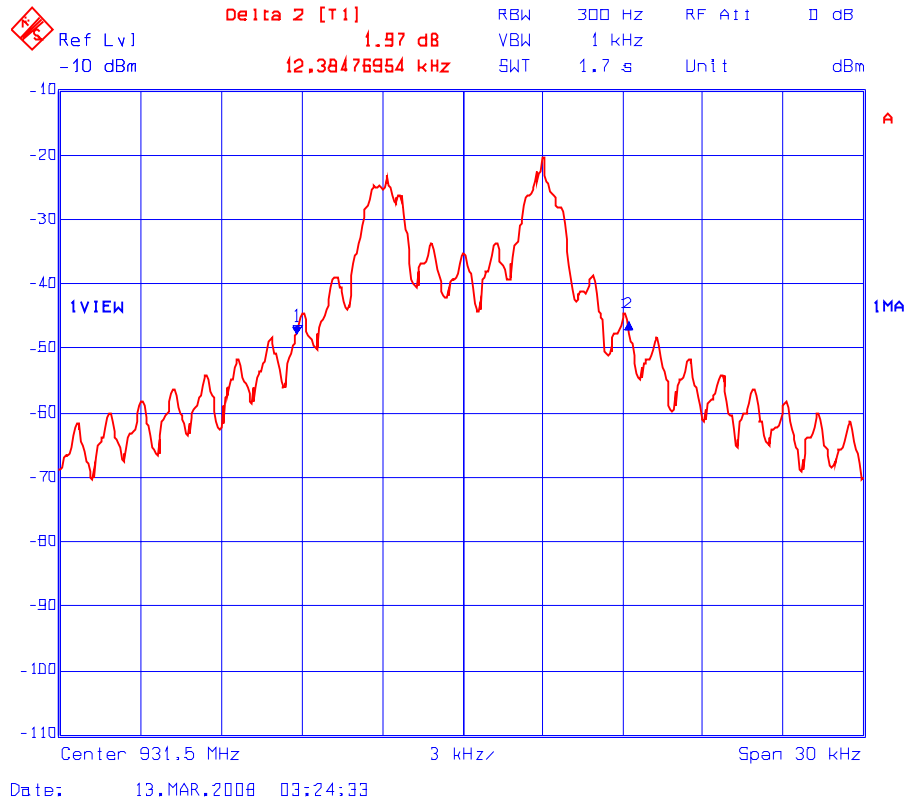

**PLOT # 10(b): 26 dB Occupied Bandwidth – RF Output Signal**  
**Centre Frequency: 931.5 MHz, Output Power: maximum**  
**Modulation: POCSAG (F1D), Data Rate: 2400 baud, Freq. Deviation =  $\pm 3$  kHz (tone)**

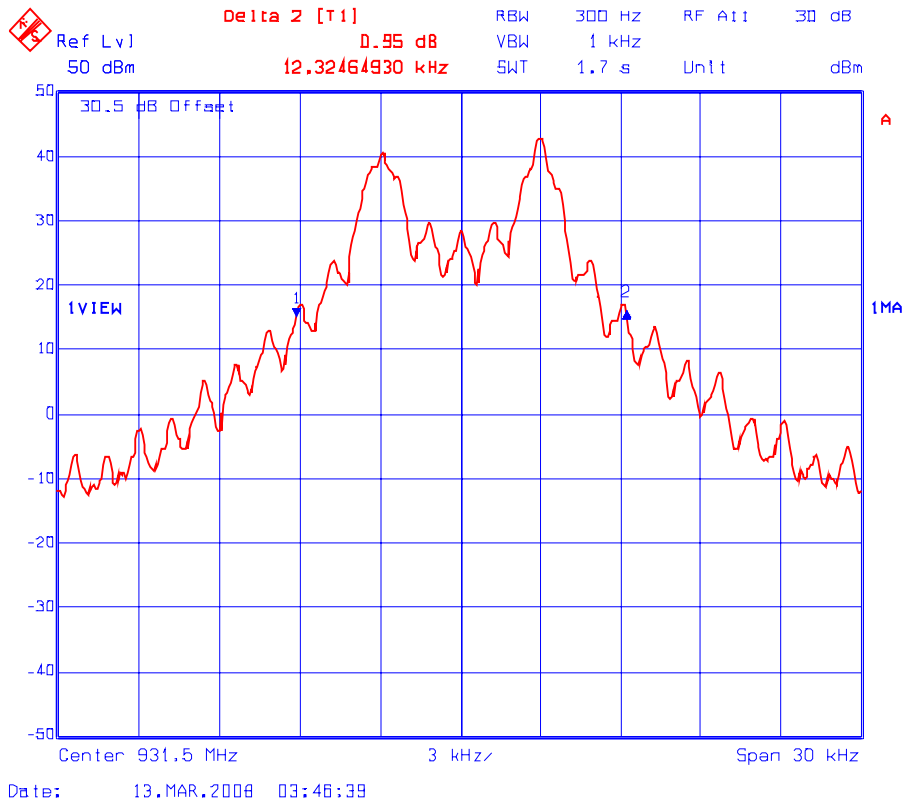

## 5.11. Band-edge and Out-of-Emissions [§ 2.1057, 2.1053 & 22.359(a)]

### 5.11.1. Limits

*Out of band emissions.* The power of any emission outside of the authorized operating frequency ranges must be attenuated below the transmitting power (P) by a factor of at least  $43 + 10\log(P)$  dB.

### 5.11.2. Method of Measurements

Refer to Exhibit 7 of this report for measurement details

### 5.11.3. Test Equipment List

Test Instruments	Manufacturer	Model No.	Serial No.	Frequency Range
Spectrum Analyzer	Advantest	R3271	15050203	100 Hz – 26.5 GHz
AF Signal Generator	HP	8920B	US39064699	DC – 20 kHz
Attenuator(s)	Weinschel Corp	46-30-34 46-10-34	BM 5354 BS 4336	DC – 18 GHz DC – 18 GHz
Digital Voltmeter	Hewlett-Packard	3456A	2015A04523	DC-250 KHz
Tunable Notch Filter	K & L	3TNT-500/1000- N/N	470	500 MHz – 1000 MHz
High Pass Filter	K & L	11SH10- 1500/T8000	2	Cut-off Freq at 750 MHz

### 5.11.4. Test Arrangement

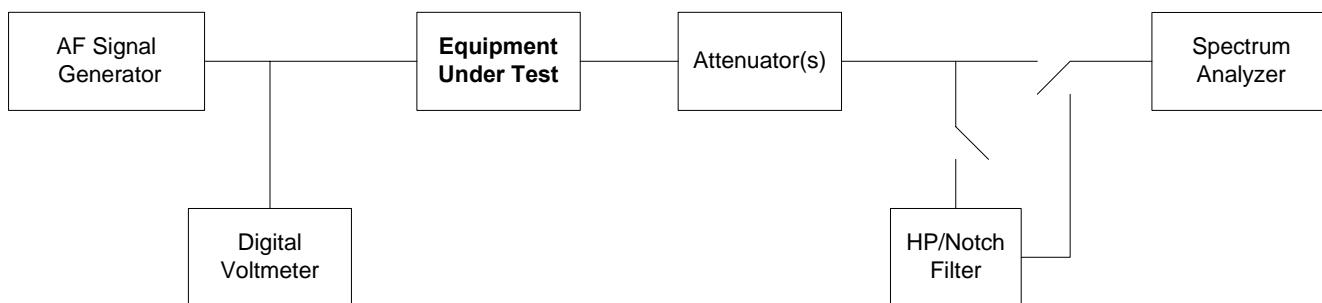

#### 5.11.5. Test Data

- Band-edge Conducted Emissions: Conforms. Please refer to Plots # 11(a)&(b) to 20(a)&(b)
- Out-of-Band Spurious Conducted Emissions: Conforms. Please refer to Plots # 21(a)&(b)

Note: Since the out-of-band spurious conducted emissions were scanned and found to be the same for all modulations, only results for F3E were recorded in this test report.



Plot # 11(a) Band-edge Conducted Emissions – Lower Band-edge (  
Frequency: 931.0125 MHz, Modulation: Analog Voice (F3E), RF Output Power: Maximum

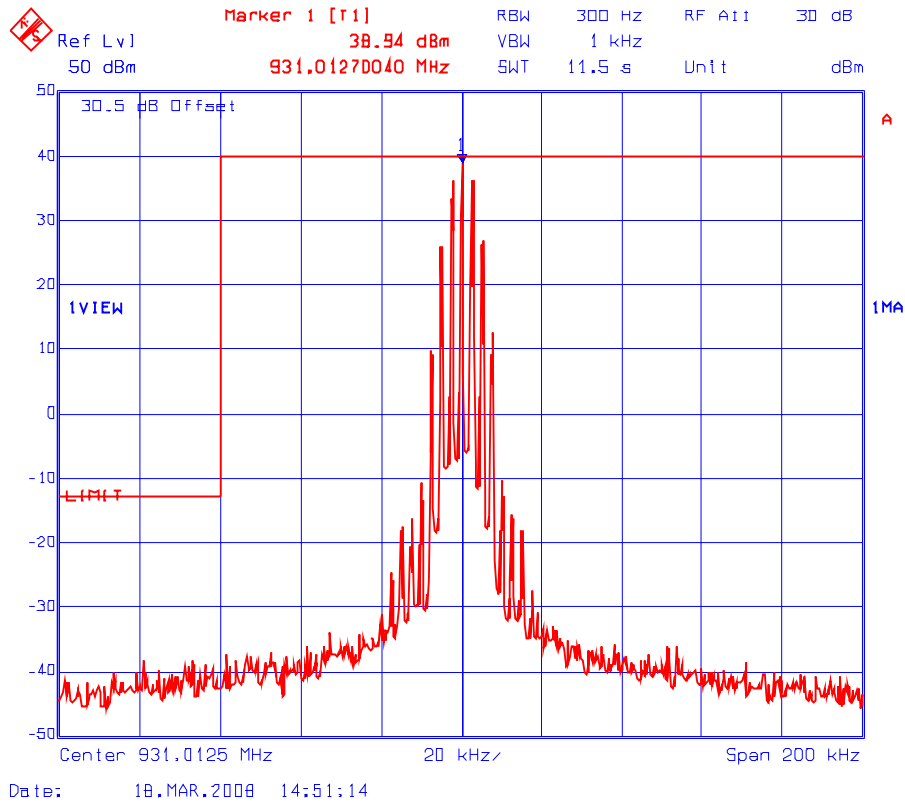

**Plot # 11(b) Band-edge Conducted Emissions – Upper Band-edge**  
**Frequency: 931.9875 M, Modulation: Analog Voice (F3E), RF Output Power: Maximum**

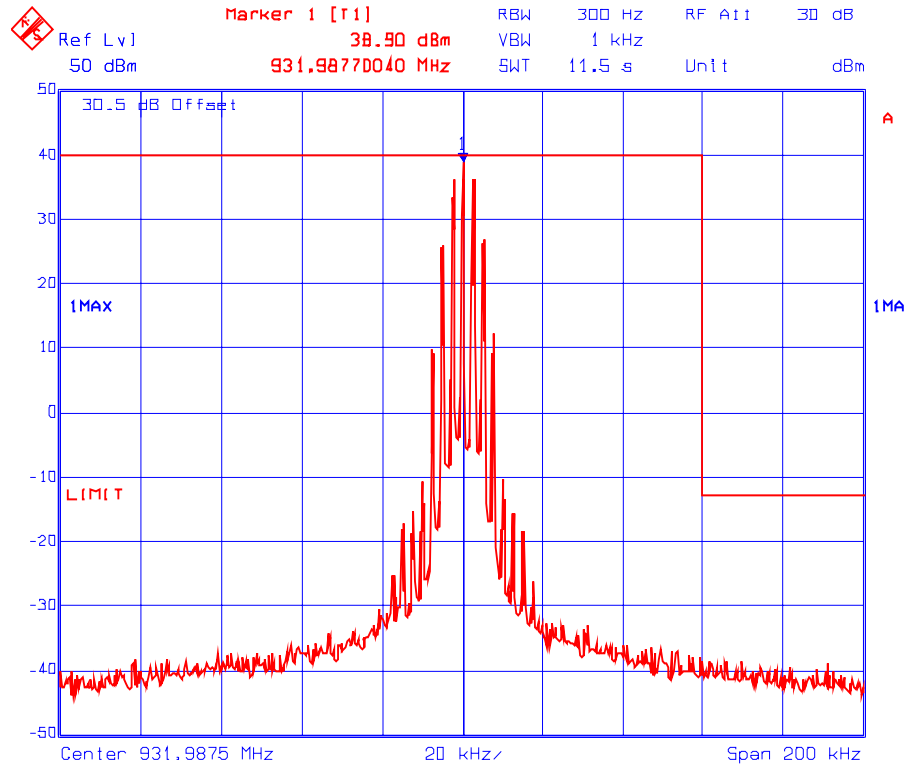

Date: 18.MAR.2008 14:53:35

Plot # 12(a) **Band-edge Conducted Emissions – Lower Band-edge**  
Frequency: 931.0125 MHz, Modulation: FFSK (F2D), Freq. Dev.:  $\pm 1.5$  kHz, RF Output Power: Maximum

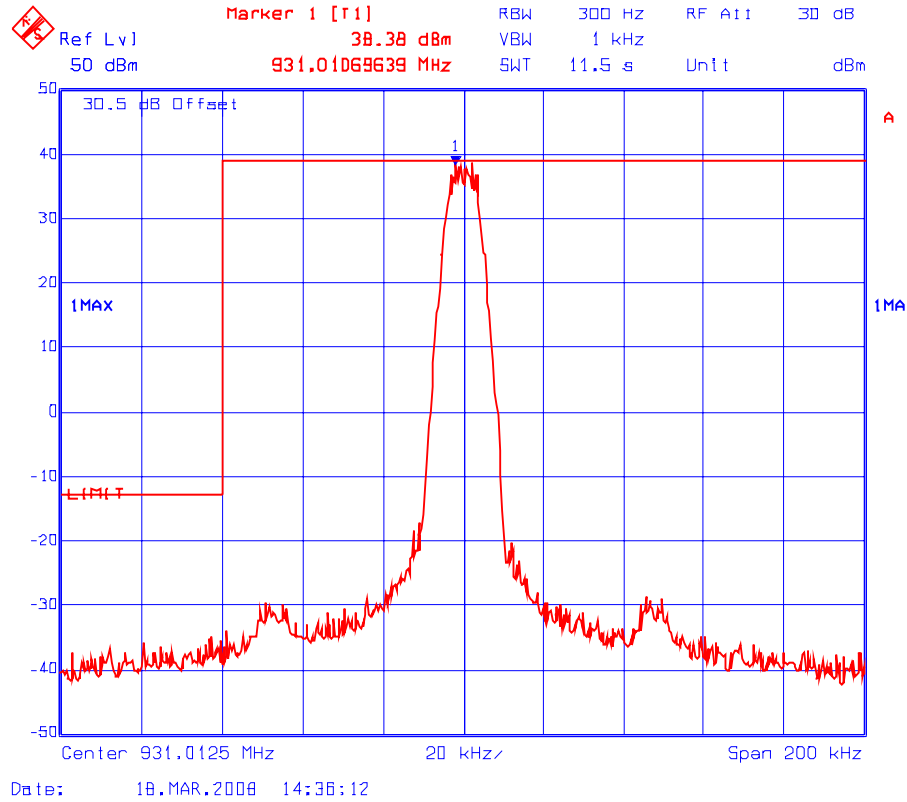

Plot # 12(b) **Band-edge Conducted Emissions – Upper Band-edge**  
Frequency: 931.9875 M, Modulation: FFSK (F2D), Freq. Dev.: ±1.5 kHz, RF Output Power: Maximum

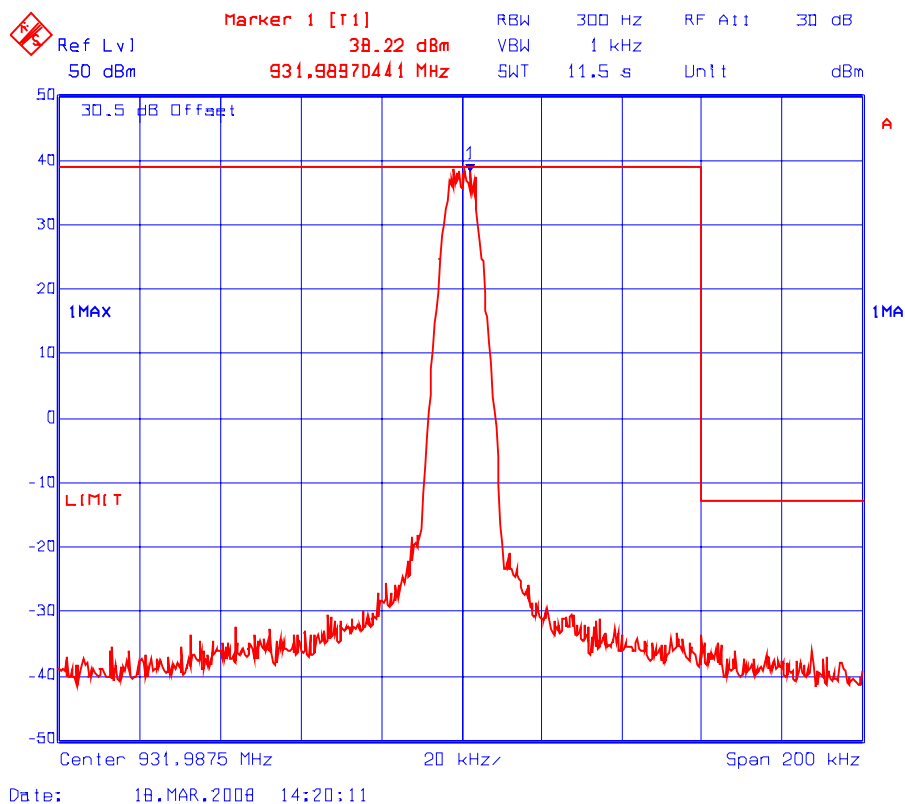

Plot # 13(a) **Band-edge Conducted Emissions – Lower Band-edge**  
Frequency: 931.0125 MHz, Modulation: FFSK (F2D), Freq. Dev.:  $\pm 3$  kHz, RF Output Power: Maximum

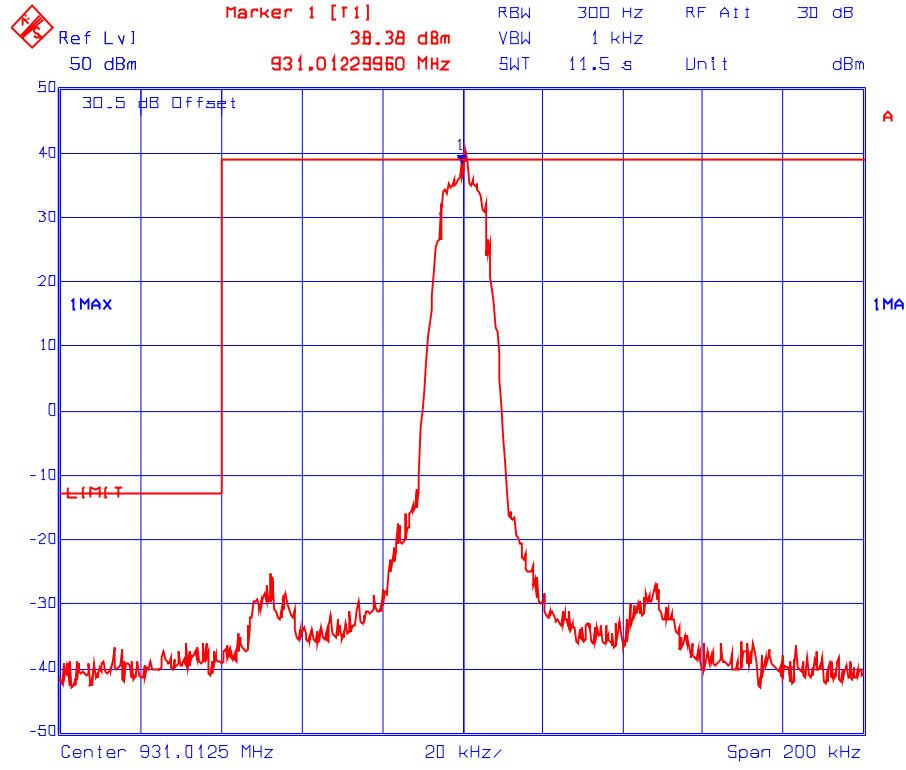

Date: 18.MAR.2008 14:34:17

**Plot # 13(b) Band-edge Conducted Emissions – Upper Band-edge**  
**Frequency: 931.9875 M, Modulation: FFSK (F2D), Freq. Dev.: ±3 kHz, RF Output Power: Maximum**

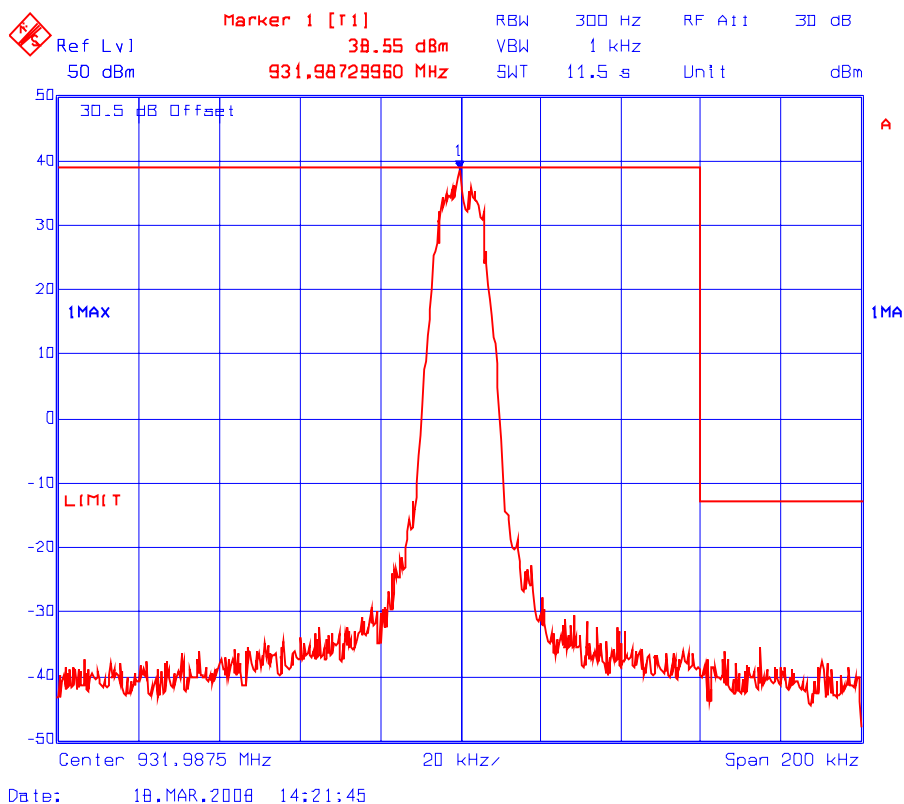

**Plot # 14(a) Band-edge Conducted Emissions – Lower Band-edge**  
**Frequency: 931.0125 MHz, Modulation: FLEX, 2-FSK 1600bps (F1D), Freq. Dev.:  $\pm 4.8$  kHz,**  
**RF Output Power: Maximum**

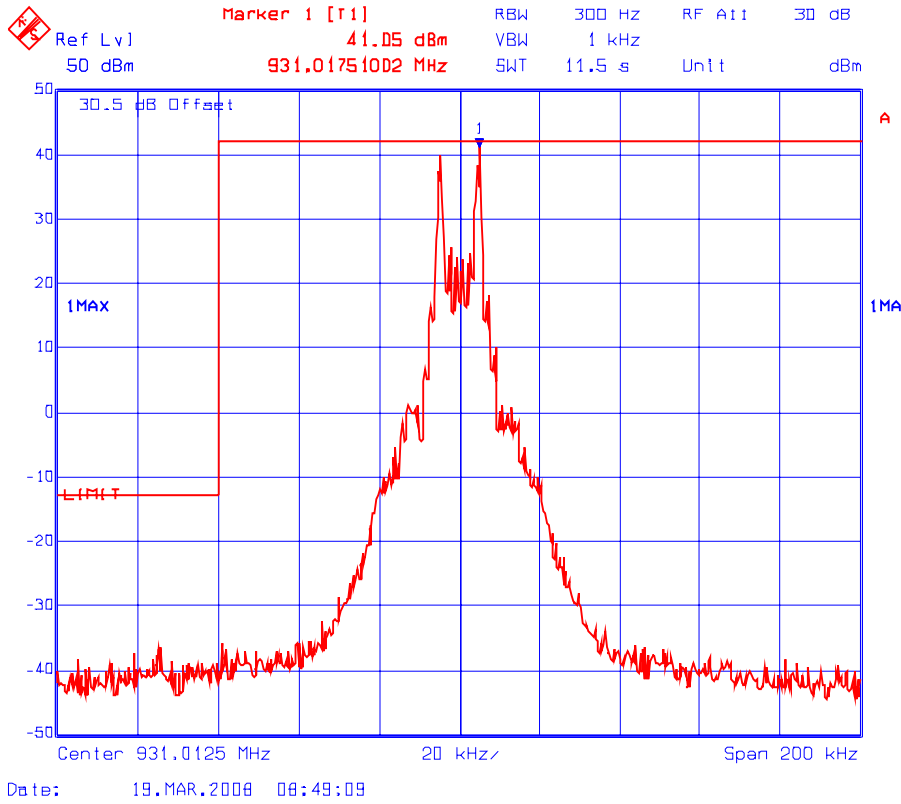

**Plot # 14(b) Band-edge Conducted Emissions – Upper Band-edge**  
**Frequency: 931.0125 MHz, Modulation: FLEX, 2-FSK 1600bps (F1D), Freq. Dev.: ±4.8 kHz,**  
**RF Output Power: Maximum**

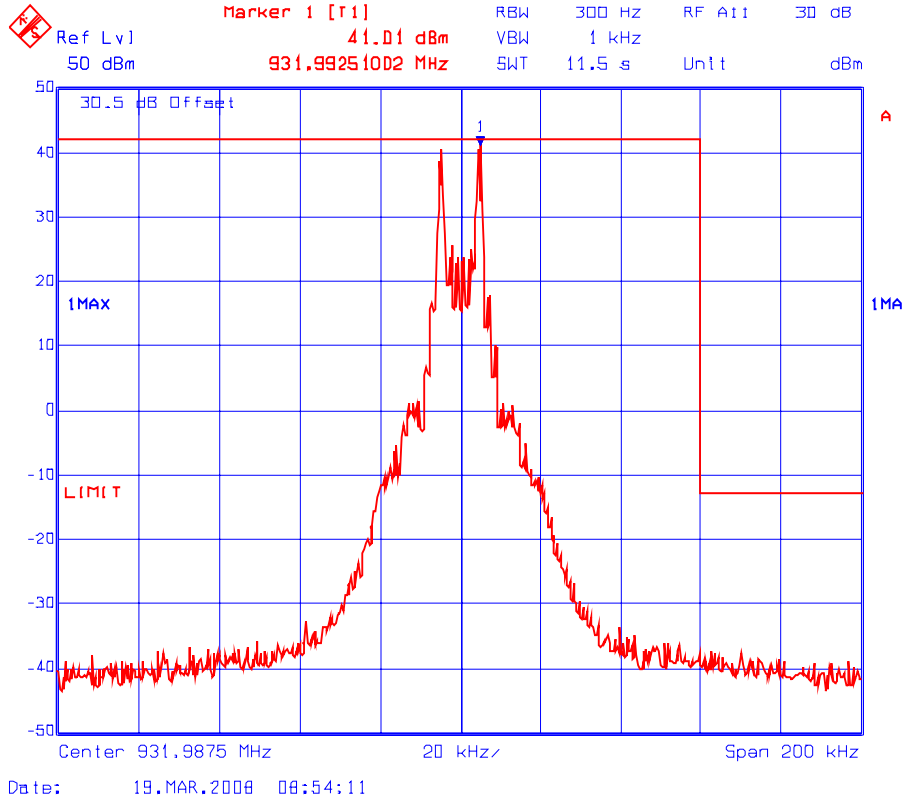



**Plot # 15(a) Band-edge Conducted Emissions – Lower Band-edge**  
**Frequency: 931.0125 MHz, Modulation: FLEX, 2-FSK 3200bps (F1D), Freq. Dev.: ±4.8 kHz,**  
**RF Output Power: Maximum**

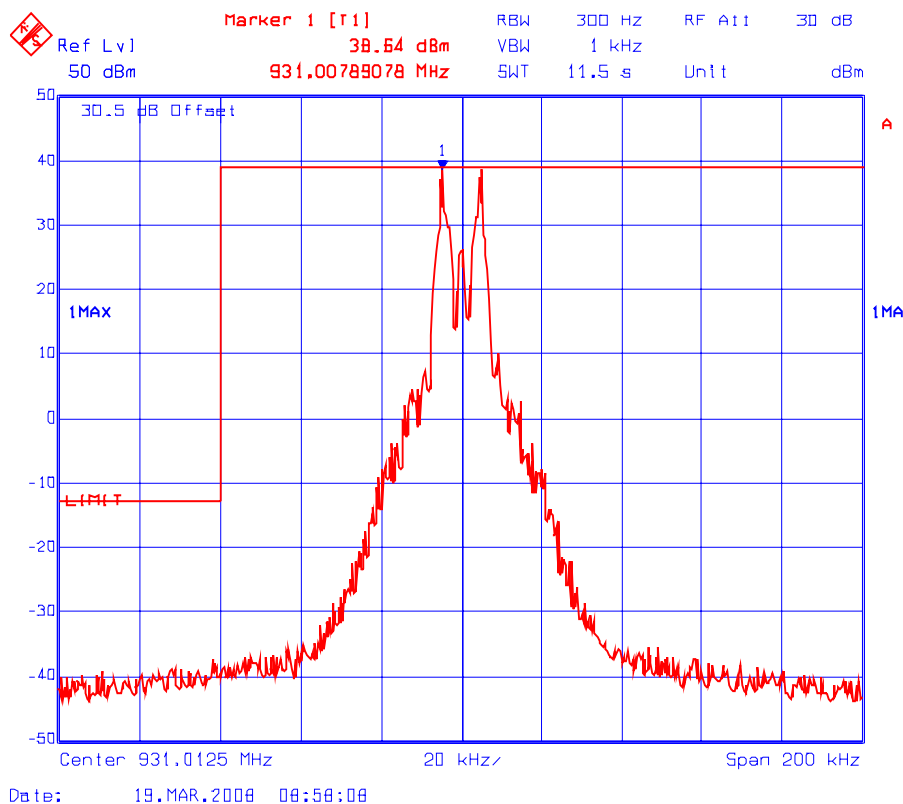

Plot # 15(b) **Band-edge Conducted Emissions – Upper Band-edge**  
**Frequency: 931.0125 MHz, Modulation: FLEX, 2-FSK 3200bps (F1D), Freq. Dev.: ±4.8 kHz,**  
**RF Output Power: Maximum**

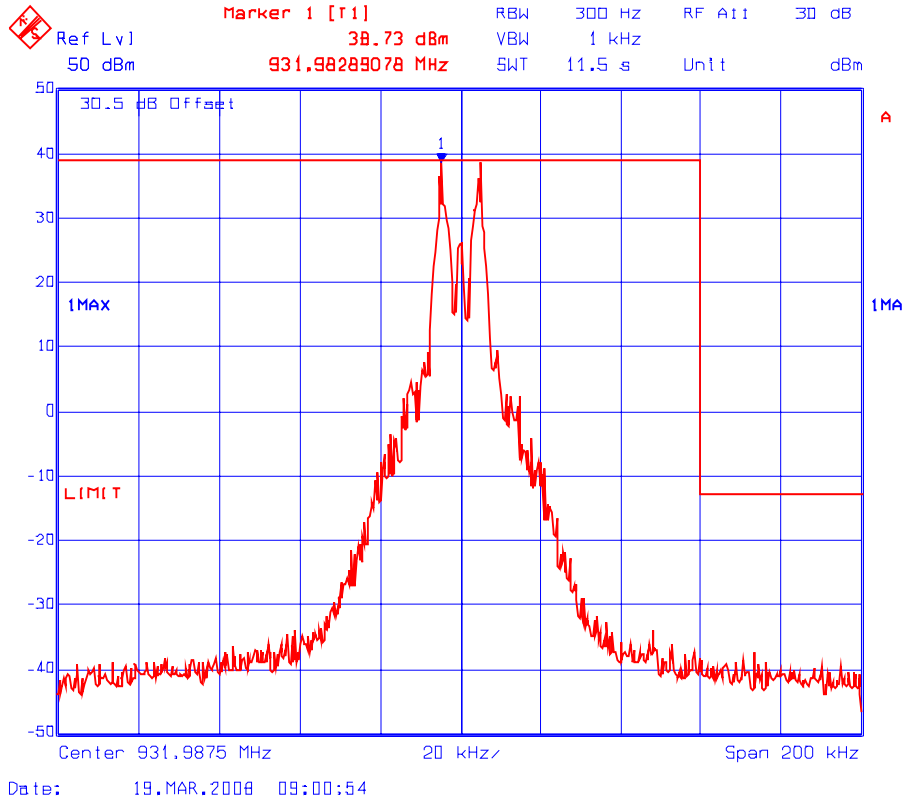

Plot # 16(a) **Band-edge Conducted Emissions – Lower Band-edge**  
Frequency: 931.0125 MHz, Modulation: FLEX, 4-FSK 3200bps (F1D), Freq. Dev.:  $\pm 4.8$  kHz,  
RF Output Power: Maximum

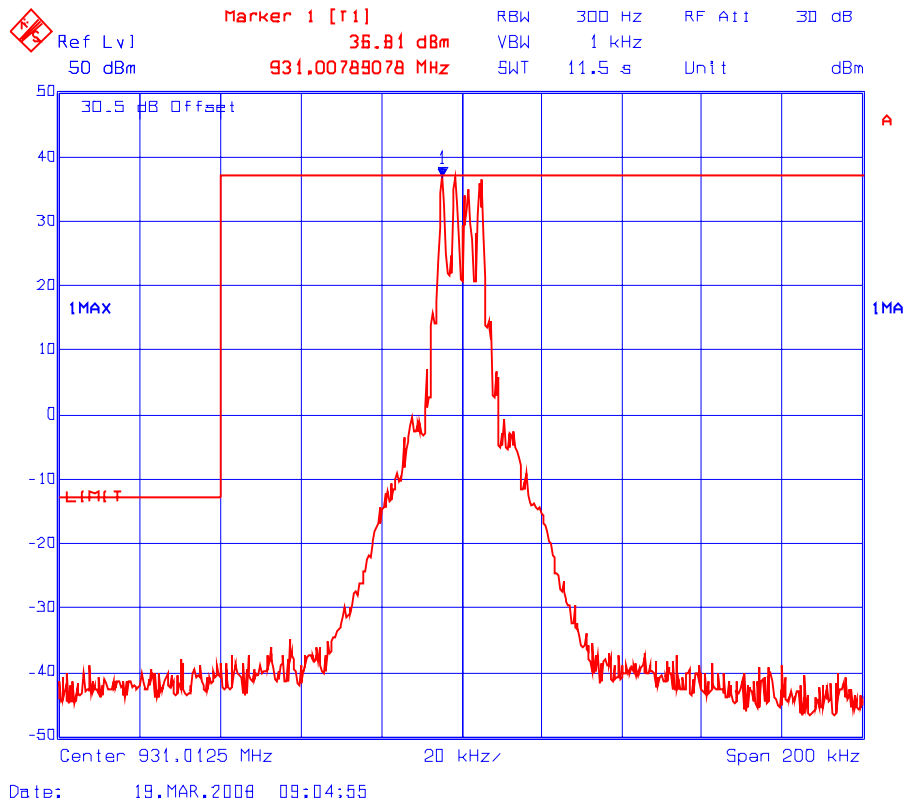

**Plot # 16(b) Band-edge Conducted Emissions – Upper Band-edge**  
**Frequency: 931.0125 MHz, Modulation: FLEX, 4-FSK 3200bps (F1D), Freq. Dev.:  $\pm 4.8$  kHz,**  
**RF Output Power: Maximum**

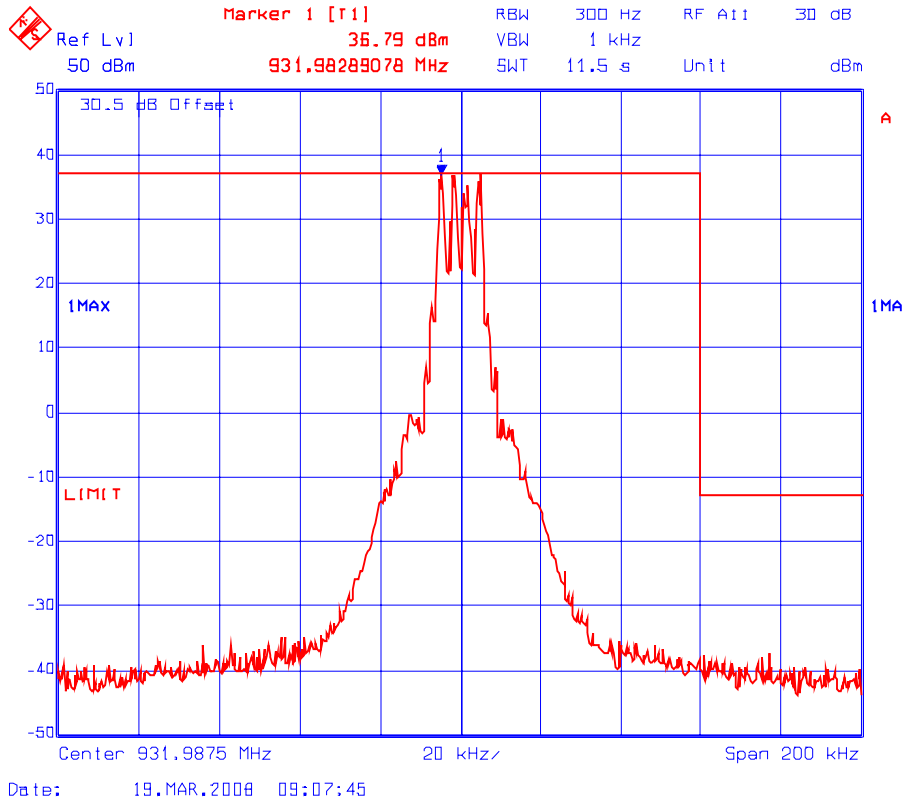

Plot # 17(a) **Band-edge Conducted Emissions – Lower Band-edge**  
**Frequency: 931.0125 MHz, Modulation: FLEX, 4-FSK 6400bps (F1D), Freq. Dev.: ±4.8 kHz,**  
**RF Output Power: Maximum**

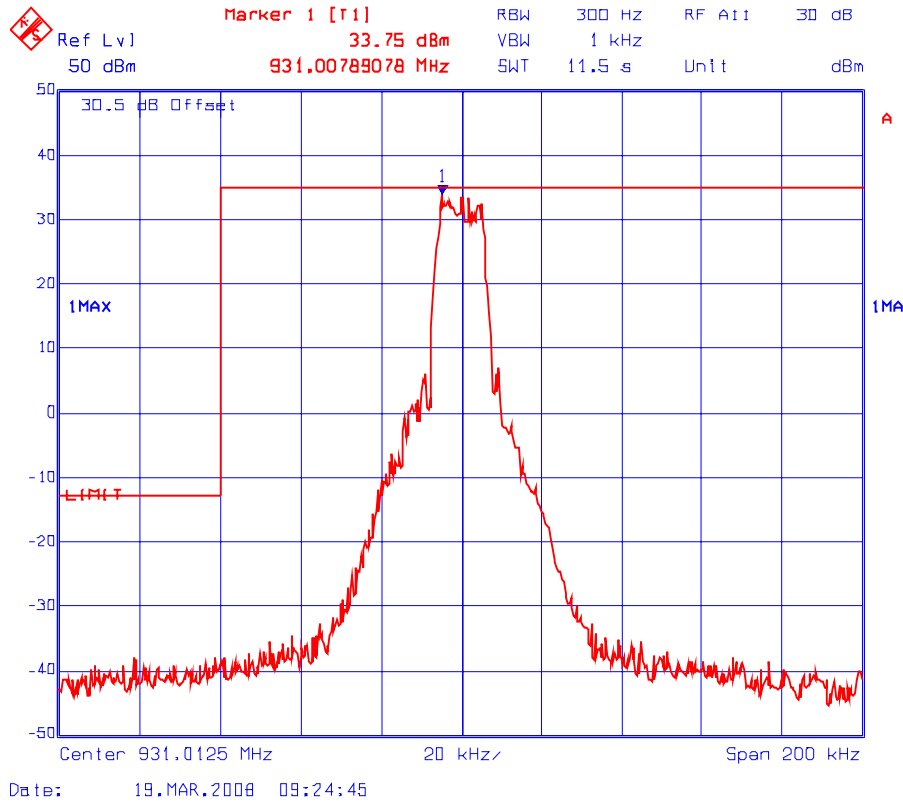

Plot # 17(b) **Band-edge Conducted Emissions – Upper Band-edge**  
**Frequency: 931.0125 MHz, Modulation: FLEX, 4-FSK 6400bps (F1D), Freq. Dev.: ±4.8 kHz,**  
**RF Output Power: Maximum**

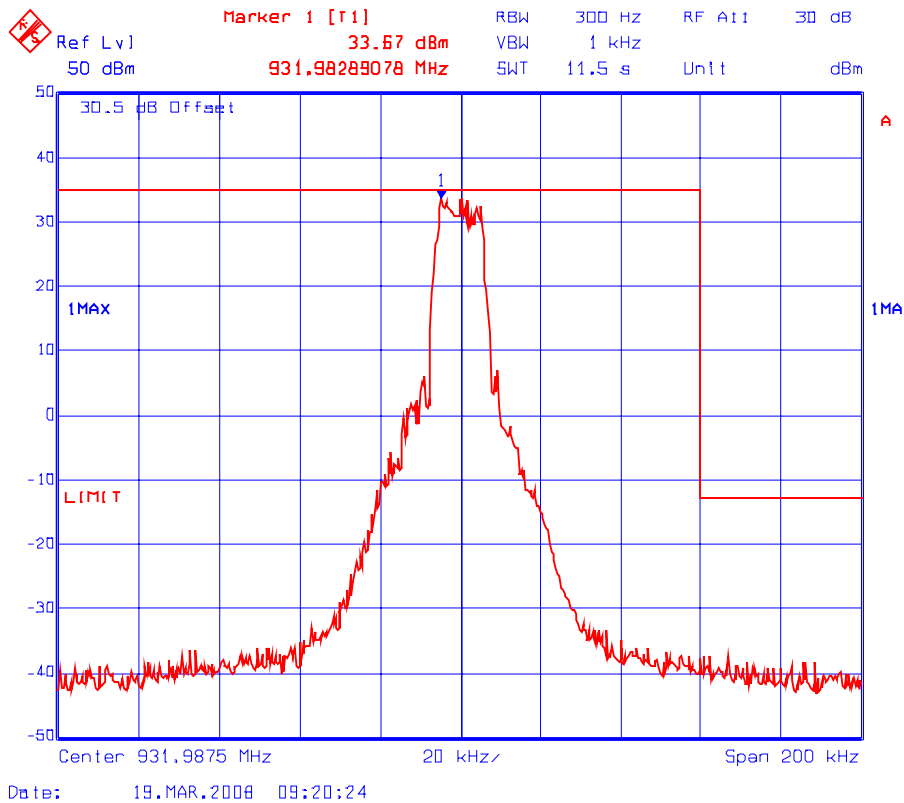

Plot # 18(a) **Band-edge Conducted Emissions – Lower Band-edge**  
Frequency: 931.0125 MHz, Modulation: POCSAG 512 baud rate (F1D), Freq. Dev.:  $\pm 3.0$  kHz,  
RF Output Power: Maximum

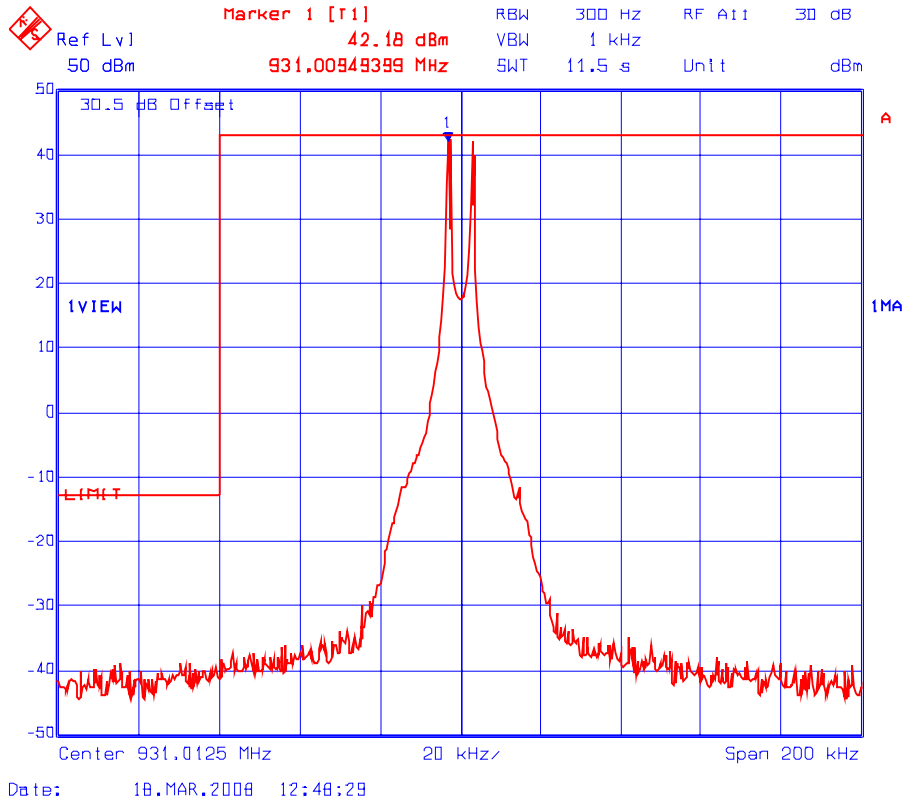

**Plot # 18(b) Band-edge Conducted Emissions – Upper Band-edge**  
**Frequency: 931.0125 MHz, Modulation: POCSAG 512 baud rate (F1D), Freq. Dev.:  $\pm 3.0$  kHz,**  
**RF Output Power: Maximum**

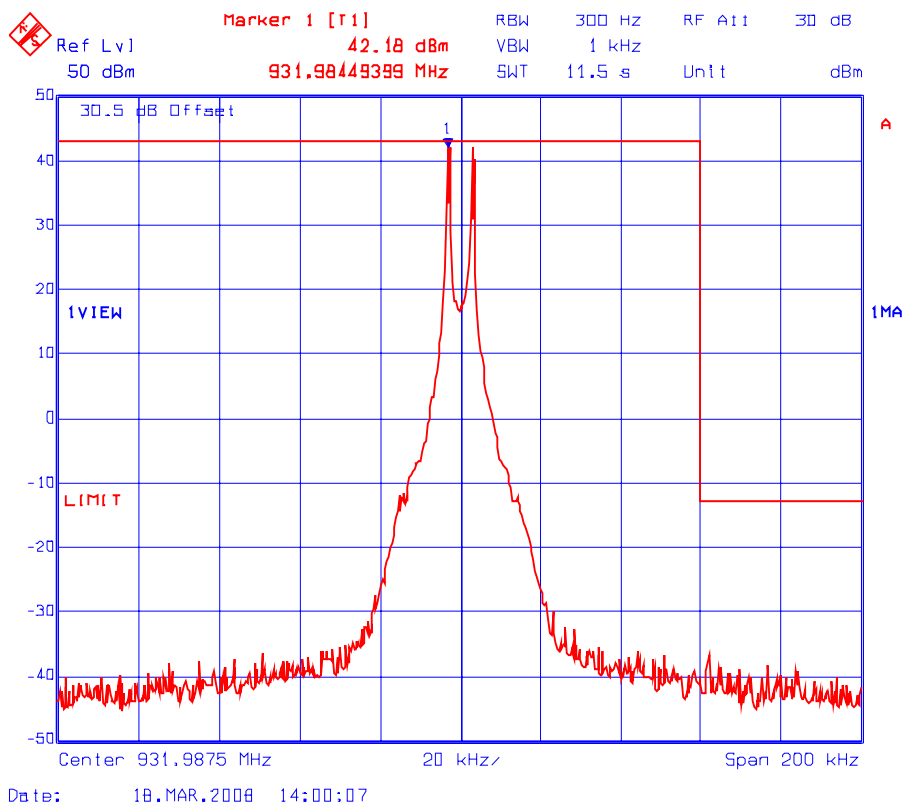



Plot # 19(a) **Band-edge Conducted Emissions – Lower Band-edge**  
Frequency: 931.0125 MHz, Modulation: POCSAG 1200 baud rate (F1D), Freq. Dev.:  $\pm 3.0$  kHz,  
RF Output Power: Maximum

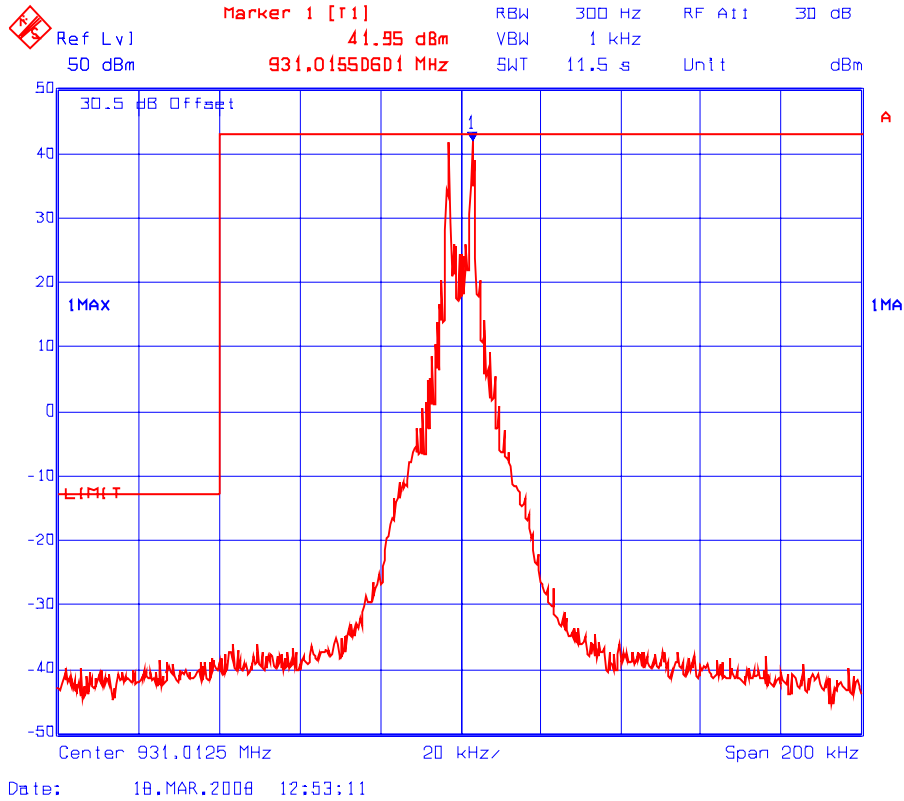

**Plot # 19(b) Band-edge Conducted Emissions – Upper Band-edge**  
**Frequency: 931.0125 MHz, Modulation: POCSAG 1200 baud rate (F1D), Freq. Dev.:  $\pm 3.0$  kHz,**  
**RF Output Power: Maximum**

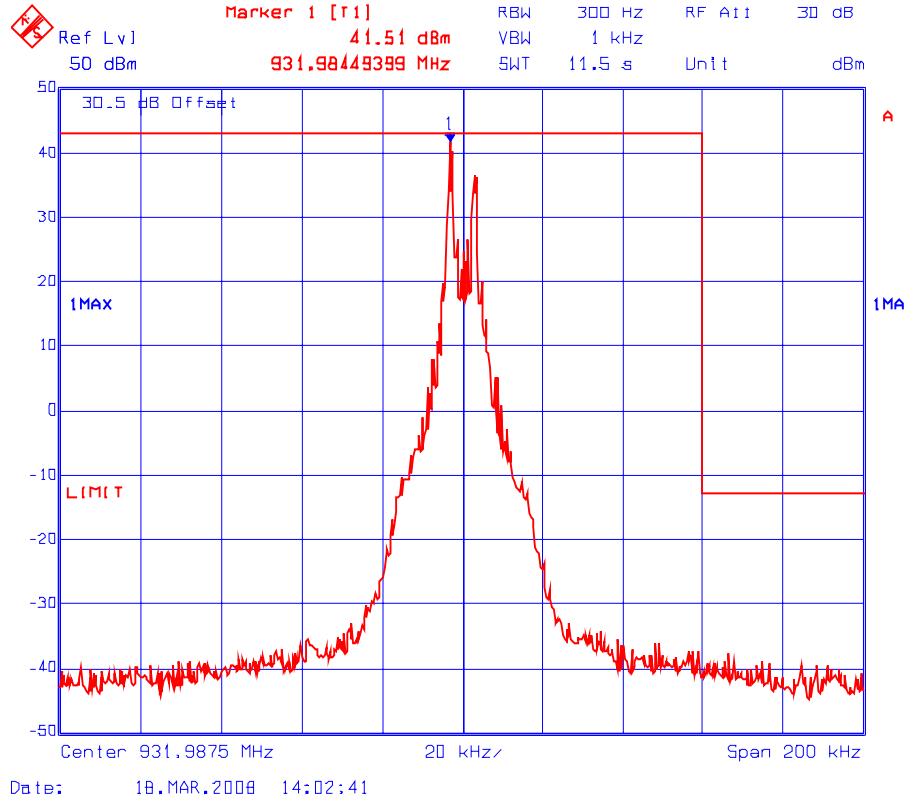

Plot # 20(a) **Band-edge Conducted Emissions – Lower Band-edge**  
Frequency: 931.0125 MHz, Modulation: POCSAG 2400 baud rate (F1D), Freq. Dev.:  $\pm 3.0$  kHz,  
RF Output Power: Maximum

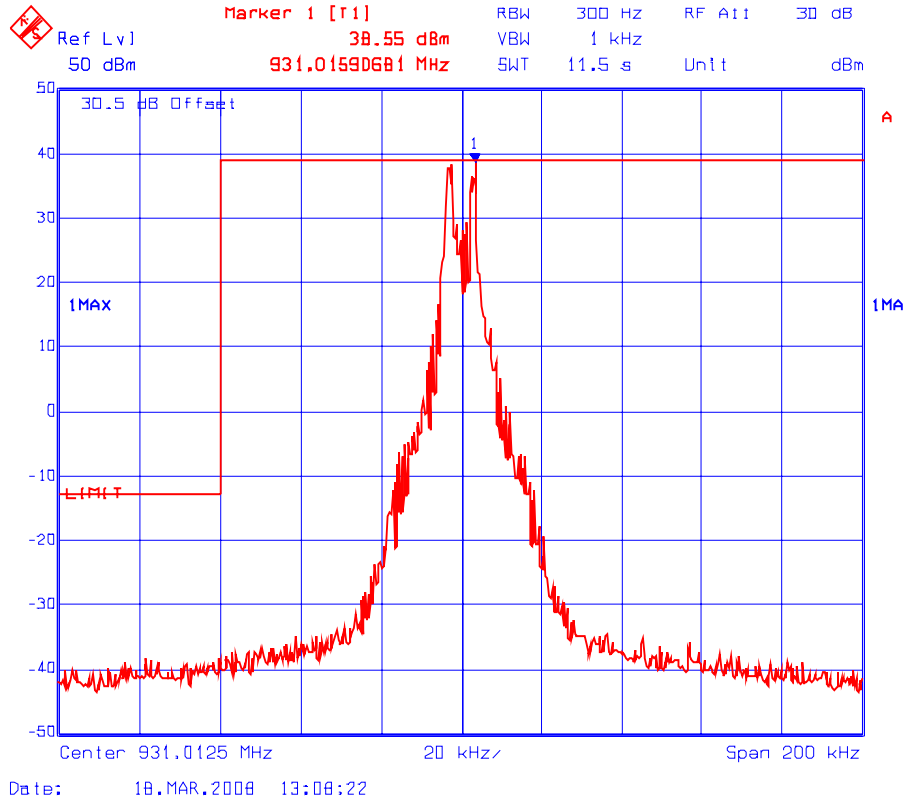

**Plot # 20(b) Band-edge Conducted Emissions – Upper Band-edge**  
**Frequency: 931.0125 MHz, Modulation: POCSAG 2400 baud rate (F1D), Freq. Dev.:  $\pm 3.0$  kHz,**  
**RF Output Power: Maximum**

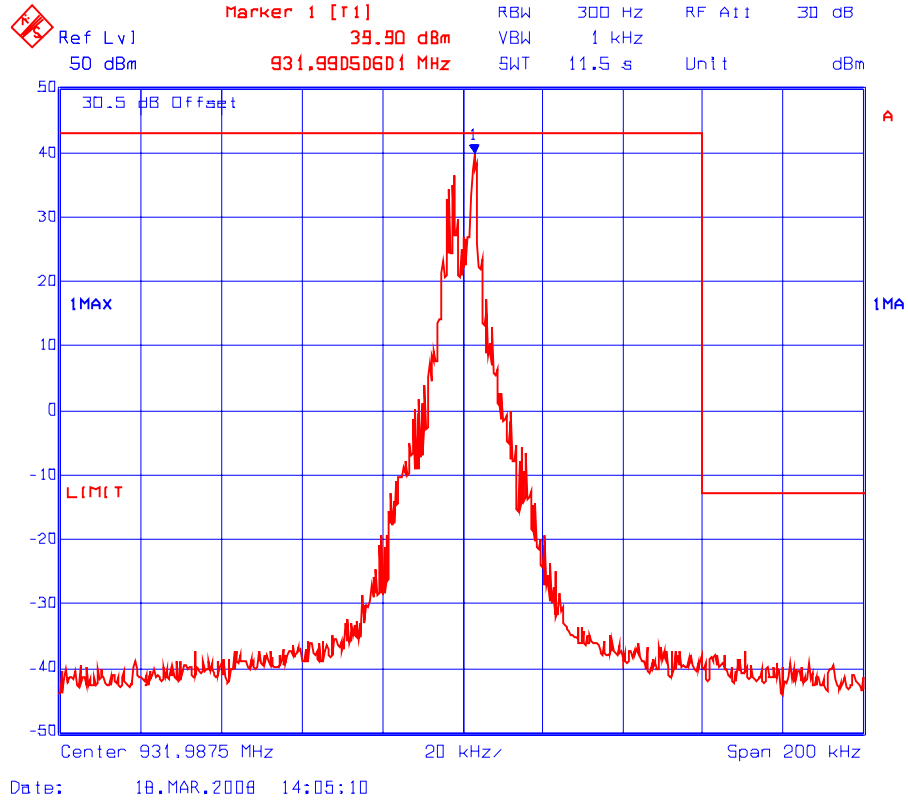

**Plot # 21(a) Conducted Spurious Emissions at Antenna Port**  
Frequency: 931.0125 MHz, Modulation: FM analog (F3E), RF Output Power: 1.0 Watt

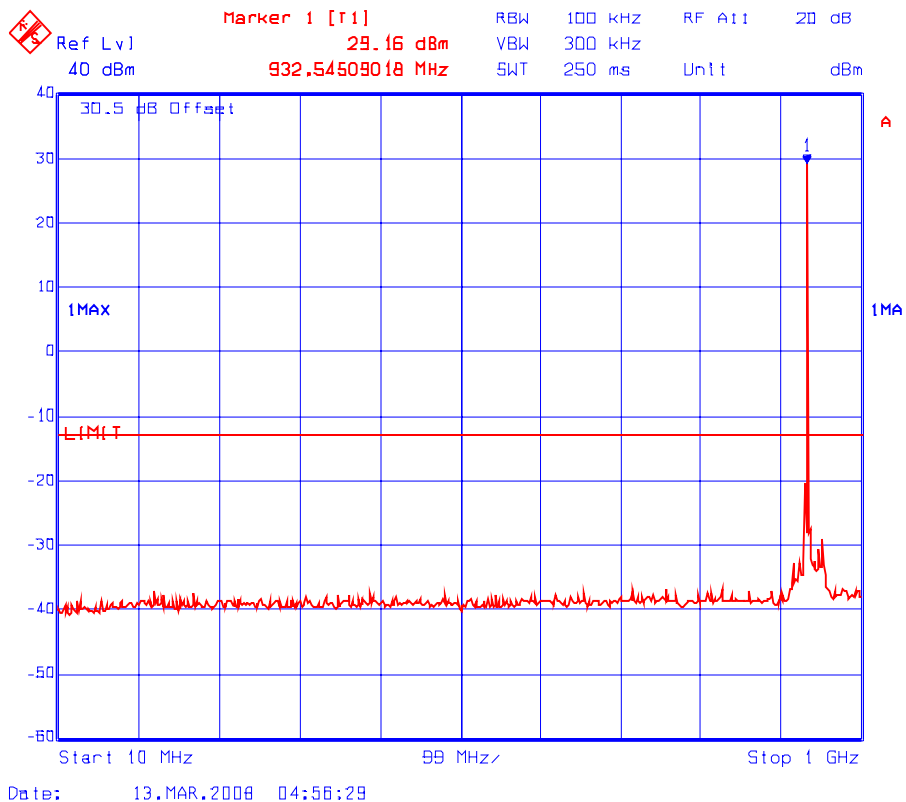

**Plot # 21(b) Conducted Spurious Emissions at Antenna Port**  
Frequency: 931.0125 MHz, Modulation: FM analog (F3E), RF Output Power: 1.0 Watt

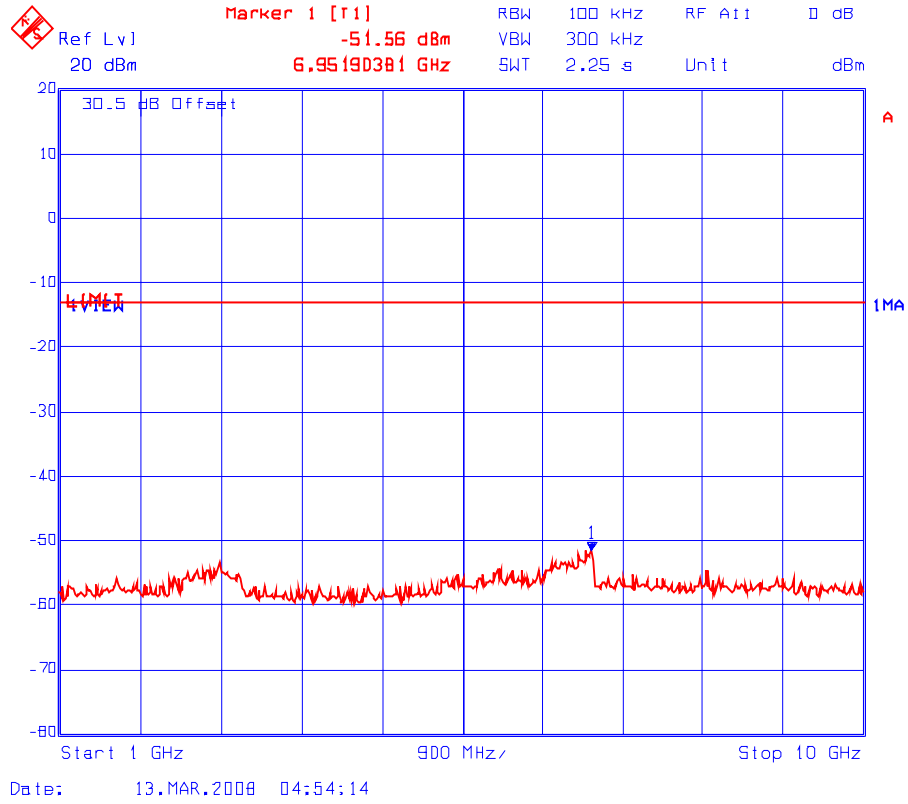

Plot # 22(a)

Conducted Spurious Emissions at Antenna Port

Frequency: 931.0125 MHz, Modulation: FM analog (F3E), RF Output Power: 20.4 Watts

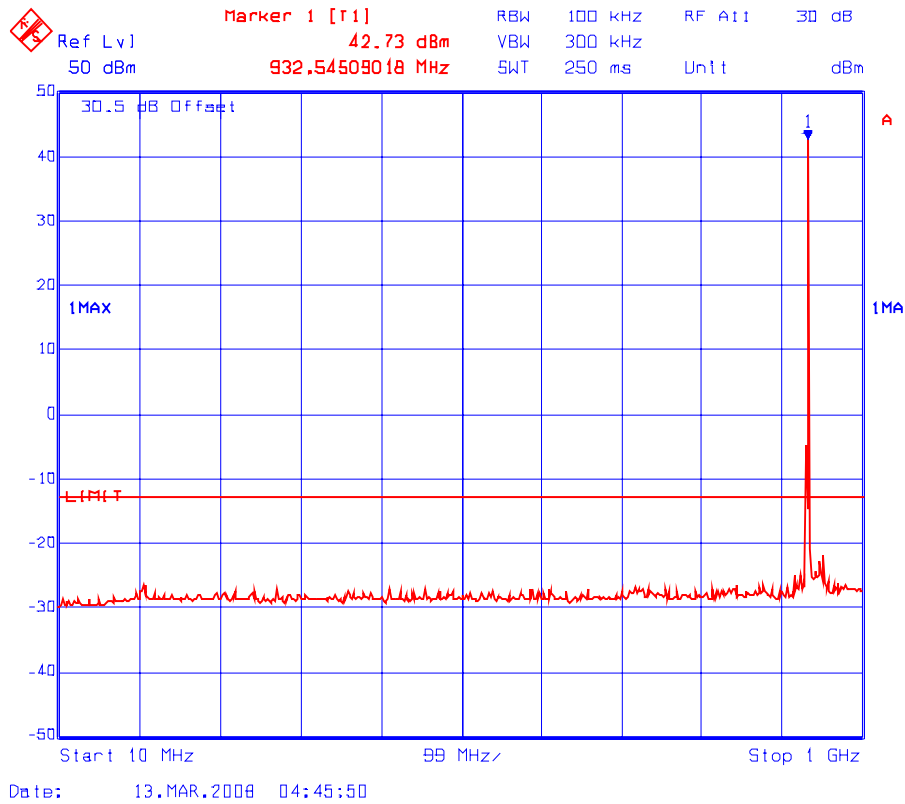

**Plot # 22(b) Conducted Spurious Emissions at Antenna Port**  
 Frequency: 931.0125 MHz, Modulation: FM analog (F3E), RF Output Power: 20.4 Watts

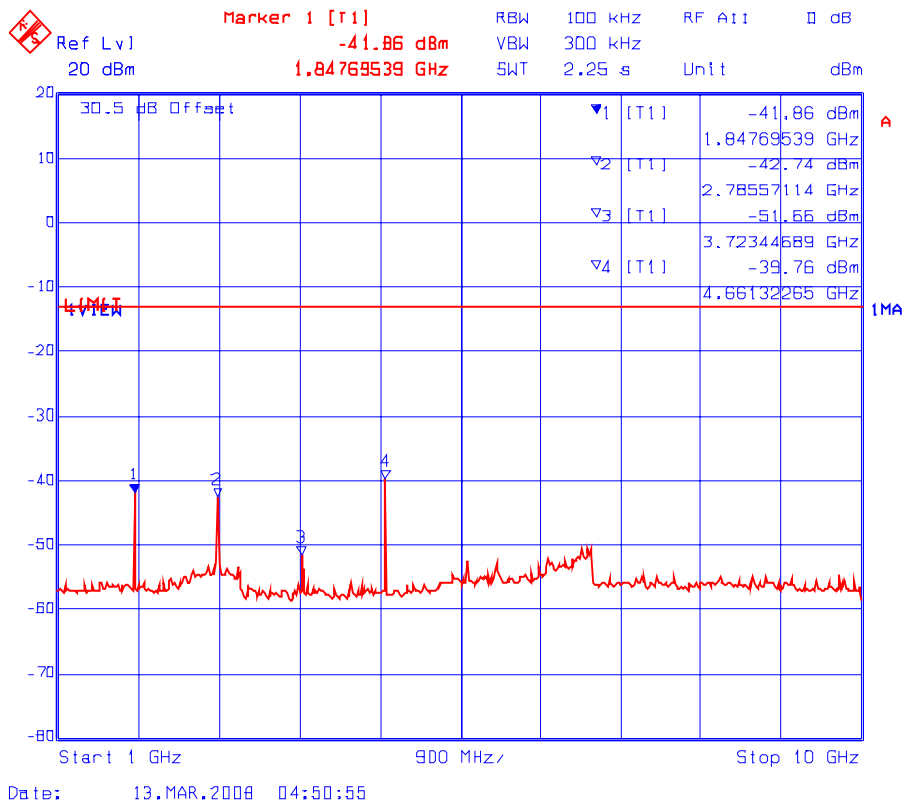



## 5.12. TRANSMITTER SPURIOUS/HARMONIC RADIATED EMISSIONS [§ 2.1057, 2.1053 & 22.359(a)]

### 5.12.1. Limits

*Out of band emissions.* The power of any emission outside of the authorized operating frequency ranges must be attenuated below the transmitting power (P) by a factor of at least  $43 + 10\log(P)$  dB.

### 5.12.2. Method of Measurements

The spurious/harmonic ERP measurements are using substitution method specified in Exhibit 7, Section 7.2 of this report and its value in dBc is calculated as follows:

- (1) If the transmitter's antenna is an integral part of the EUT, the ERP is measured using substitution method.
- (2) If the transmitter's antenna is non-integral and diverse, the lowest ERP of the carrier with 0 dBi antenna gain is used for calculation of the spurious/harmonic emissions in dBc:  
 Lowest ERP of the carrier = EIRP - 2.15 dB =  $P_c + G - 2.15$  dB = xxx dBm (conducted) + 0 dBi - 2.15 dB
- (3) Spurious /harmonic emissions levels expressed in dBc (dB below carrier) are as follows:

$$\text{ERP of spurious/harmonic (dBc)} = \text{ERP of carrier (dBm)} - \text{ERP of spurious/harmonic emission (dBm)}$$

### 5.12.3. Test Equipment List

Test Instruments	Manufacturer	Model No.	Serial No.	Frequency Range
Spectrum Analyzer/ EMI Receiver	Hewlett Packard	HP 8546A	...	9 kHz to 5.6 GHz with built-in 30 dB Gain Pre-selector, QP, Average & Peak Detectors.
RF Amplifier	Com-Power	PA-102		1 MHz to 1 GHz, 30 dB gain nominal
Microwave Amplifier	Hewlett Packard	HP 83017A		1 GHz to 26.5 GHz, 30 dB nominal
Biconilog Antenna	EMCO	3142	10005	30 MHz to 2 GHz
Horn Antenna	EMCO	3155	9701-5061	1 GHz - 18 GHz
RF Signal Generator	Hewlett Packard	HP 83752B	3610A00457	0.01 - 20 GHz

### 5.12.4. Test Data

- The radiated emissions were performed at 3 meters distance. At its centre frequency (931.5 MHz) and maximum power for worst case (20.3 Watts) .
- The emissions were scanned from 30 MHz to 10 GHz; no emissions less than 40 dB below the limit are found and recorded.

## EXHIBIT 6. MEASUREMENT UNCERTAINTY

The measurement uncertainties stated were calculated in accordance with the requirements of NIST Technical Note 1297 and NIS 81 (1994)

### 6.1. Radiated Emission Measurement Uncertainty

CONTRIBUTION (Radiated Emissions)	PROBABILITY DISTRIBUTION	UNCERTAINTY ( $\pm$ dB)	
		3 m	10 m
Antenna Factor Calibration	Normal (k=2)	$\pm 1.0$	$\pm 1.0$
Cable Loss Calibration	Normal (k=2)	$\pm 0.3$	$\pm 0.5$
EMI Receiver specification	Rectangular	$\pm 1.5$	$\pm 1.5$
Antenna Directivity	Rectangular	+0.5	+0.5
Antenna factor variation with height	Rectangular	$\pm 2.0$	$\pm 0.5$
Antenna phase center variation	Rectangular	0.0	$\pm 0.2$
Antenna factor frequency interpolation	Rectangular	$\pm 0.25$	$\pm 0.25$
Measurement distance variation	Rectangular	$\pm 0.6$	$\pm 0.4$
Site imperfections	Rectangular	$\pm 2.0$	$\pm 2.0$
Mismatch: Receiver VRC $\Gamma_1 = 0.2$ Antenna VRC $\Gamma_R = 0.67$ (Bi) 0.3 (Lp) Uncertainty limits $20\text{Log}(1 \pm \Gamma_1 \Gamma_R)$	U-Shaped	+1.1 -1.25	$\pm 0.5$
System repeatability	Std. Deviation	$\pm 0.5$	$\pm 0.5$
Repeatability of EUT		-	-
Combined standard uncertainty	Normal	+2.19 / -2.21	+1.74 / -1.72
Expanded uncertainty U	Normal (k=2)	+4.38 / -4.42	+3.48 / -3.44

Calculation for maximum uncertainty when 3m biconical antenna including a factor of k = 2 is used:

$$U = 2u_c(y) = 2x(+2.19) = +4.38 \text{ dB} \quad \text{And} \quad U = 2u_c(y) = 2x(-2.21) = -4.42 \text{ dB}$$

## EXHIBIT 7. MEASUREMENT METHODS

### 7.1. CONDUCTED POWER MEASUREMENTS

- The following shall be applied to the combination(s) of the radio device and its intended antenna(e).
- If the RF level is user adjustable, all measurements shall be made with the highest power level available to the user for that combination.
- The following method of measurement shall apply to both conducted and radiated measurements.
- The radiated measurements are performed at the Ultratech Calibrated Open Field Test Site.
- The measurement shall be performed using normal operation of the equipment with modulation.

Test procedure shall be as follows:

**Step 1:** Duty Cycle measurements if the transmitter's transmission is transient

- Using a EMI Receiver with the frequency span set to 0 Hz and the sweep time set at a suitable value to capture the envelope peaks and the duty cycle of the transmitter output signal;
- The duty cycle of the transmitter,  $x = T_x \text{ on} / (T_x \text{ on} + T_x \text{ off})$  with  $0 < x < 1$ , is measure and recorded in the test report. For the purpose of testing, the equipment shall be operated with a duty cycle that is equal or more than 0.1.

**Step 2:** Calculation of Average EIRP. See Figure 1

- The average output power of the transmitter shall be determined using a wideband, calibrated RF average power meter with the power sensor with an integration period that exceeds the repetition period of the transmitter by a factor 5 or more. The observed value shall be recorded as "A" (in dBm);
- The e.i.r.p. shall be calculated from the above measured power output "A", the observed duty cycle x, and the applicable antenna assembly gain "G" in dBi, according to the formula:

$$\text{EIRP} = \text{A} + \text{G} + 10\log(1/x)$$

{ X = 1 for continuous transmission =>  $10\log(1/x) = 0 \text{ dB}$  }

**Figure 1.**

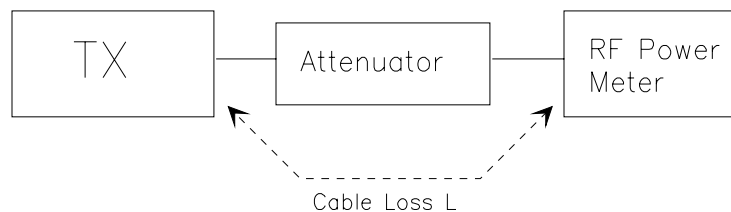

## 7.2. RADIATED POWER MEASUREMENTS (ERP & EIRP) USING SUBSTITUTION METHOD

### 7.2.1. Maximizing RF Emission Level (E-Field)

- (a) The measurements were performed with full rf output power and modulation.
- (b) Test was performed at listed 3m open area test site (listed with FCC, IC, ITI, NVLAP, ACA & VCCI).
- (c) The transmitter under test was placed at the specified height on a non-conducting turntable (80 cm height)
- (d) The BICONILOG antenna (20 MHz to 1 GHz) or HORN antenna (1 GHz to 18 GHz) was used for measuring.
- (e) Load an appropriate correction factors file in EMI Receiver for correcting the field strength reading level

Total Correction Factor recorded in the EMI Receiver = Cable Loss + Antenna Factor  
 $E \text{ (dB}\mu\text{V/m)} = \text{Reading (dB}\mu\text{V)} + \text{Total Correction Factor (dB/m)}$

- (f) Set the EMI Receiver and #2 as follows:

Center Frequency: test frequency  
Resolution BW: 100 kHz  
Video BW: same  
Detector Mode: positive  
Average: off  
Span: 3 x the signal bandwidth

- (g) The test antenna was lowered or raised from 1 to 4 meters until the maximum signal level was detected.
- (h) The transmitter was rotated through 360° about a vertical axis until a higher maximum signal was received.
- (i) The test antenna was lowered or raised again from 1 to 4 meters until a maximum was obtained. This level was recorded.
- (j) The recorded reading was corrected to the true field strength level by adding the antenna factor, cable loss and subtracting the pre-amplifier gain.
- (k) The above steps were repeated with both transmitters' antenna and test receiving antenna placed in vertical and horizontal polarization. Both readings with the antennas placed in vertical and horizontal polarization shall be recorded.
- (l) Repeat for all different test signal frequencies.

### 7.2.2. Measuring the EIRP of Spurious/Harmonic Emissions using Substitution Method

(a) Set the EMI Receiver (for measuring E-Field) and Receiver #2 (for measuring EIRP) as follows:

Center Frequency: equal to the signal source  
Resolution BW: 10 kHz  
Video BW: same  
Detector Mode: positive  
Average: off  
Span: 3 x the signal bandwidth

(b) Load an appropriate correction factors file in EMI Receiver for correcting the field strength reading level

Total Correction Factor recorded in the EMI Receiver = Cable Loss + Antenna Factor  
 $E \text{ (dBuV/m)} = \text{Reading (dBuV)} + \text{Total Correction Factor (dB/m)}$

(c) Select the frequency and E-field levels obtained in the Section 8.2.1 for ERP/EIRP measurements.

(d) Substitute the EUT by a signal generator and one of the following transmitting antenna (substitution antenna):

- ◆ DIPOLE antenna for frequency from 30-1000 MHz or
- ◆ HORN antenna for frequency above 1 GHz }

(e) Mount the transmitting antenna at 1.5 meter high from the ground plane.

(f) Use one of the following antenna as a receiving antenna:

- ◆ DIPOLE antenna for frequency from 30-1000 MHz or
- ◆ HORN antenna for frequency above 1 GHz }

(g) If the DIPOLE antenna is used, tune it's elements to the frequency as specified in the calibration manual.

(h) Adjust both transmitting and receiving antenna in a VERTICAL polarization.

(i) Tune the EMI Receivers to the test frequency.

(j) Lower or raise the test antenna from 1 to 4 meters until the maximum signal level was detected.

(k) The transmitter was rotated through 360° about a vertical axis until a higher maximum signal was received.

(l) Lower or raise the test antenna from 1 to 4 meters until the maximum signal level was detected.

(m) Adjust input signal to the substitution antenna until an equal or a known related level to that detected from the transmitter was obtained in the test receiver.

(n) Record the power level read from the Average Power Meter and calculate the ERP/EIRP as follows:

$$P = P1 - L1 = (P2 + L2) - L1 = P3 + A + L2 - L1$$

$$\text{EIRP} = P + G1 = P3 + L2 - L1 + A + G1$$

$$\text{ERP} = \text{EIRP} - 2.15 \text{ dB}$$

$$\text{Total Correction factor in EMI Receiver \# 2} = L2 - L1 + G1$$

Where: P: Actual RF Power fed into the substitution antenna port after corrected.

P1: Power output from the signal generator

P2: Power measured at attenuator A input

P3: Power reading on the Average Power Meter

EIRP: EIRP after correction

ERP: ERP after correction

(o) Adjust both transmitting and receiving antenna in a HORIZONTAL polarization, then repeat step (k) to (o)

(p) Repeat step (d) to (o) for different test frequency

(q) Repeat steps (c) to (j) with the substitution antenna oriented in horizontal polarization.

(r) Actual gain of the EUT's antenna is the difference of the measured EIRP and measured RF power at the RF port. Correct the antenna gain if necessary.

Figure 2

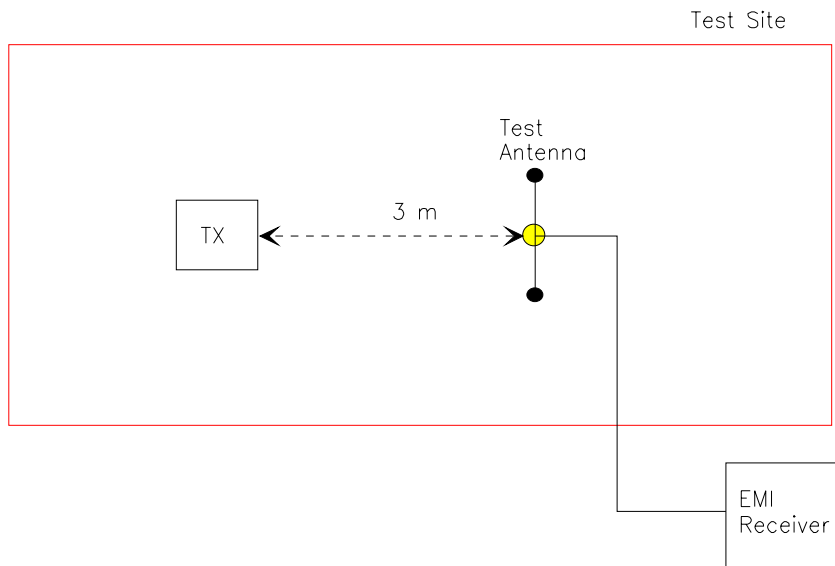
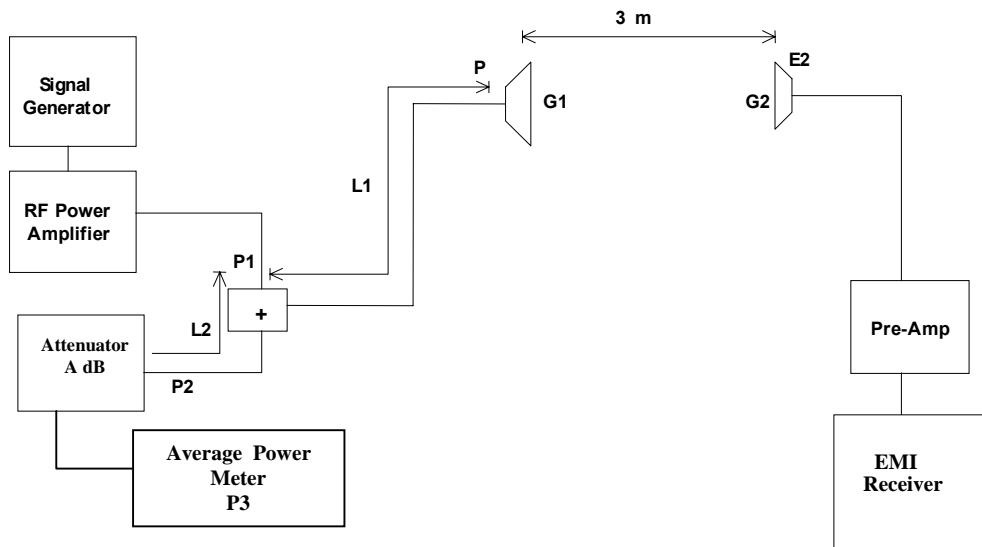

Figure 3



### 7.3. SPURIOUS EMISSIONS (CONDUCTED)

With transmitter modulation characteristics described in Out-of-Band Emissions measurements @ 2.1049, the transmitter spurious and harmonic emissions were scanned. The spurious and harmonic emissions were measured with the EMI Receiver controls set as RBW = 30 kHz minimum, VBW  $\geq$  RBW and SWEEP TIME = AUTO). The transmitter was operated at a full rated power output, and modulated as follows:

FCC CFR 47, Para. 2.1057 - Frequency spectrum to be investigated:- The spectrum was investigated from the lowest radio generated in the equipment up to at least the 10<sup>th</sup> harmonic of the carrier frequency or to the highest frequency practicable in the present state of the art of measuring techniques, whichever is lower. Particular attention should be paid to harmonics and subharmonics of the carrier frequency. Radiation at the frequencies of multiplier stages should be checked. The amplitude of spurious emissions which are attenuated more than 20 dB below the permissible value need not be reported.

FCC CFR 47, Para. 2.1051 - Spurious Emissions at Antenna Terminal:- The radio frequency voltage or powers generated within the equipment and appearing on a spurious frequency shall be checked at the equipment output terminals when properly loaded with a suitable artificial antenna. Curves or equivalent data shall show the magnitude of the harmonic and other spurious emission that can be detected when the equipment is operated under the conditions specified in 2.1049 as appropriate. The magnitude of spurious emissions which are attenuated more than 20 dB below the permissible value need not be specified.