

ENGINEERING TEST REPORT

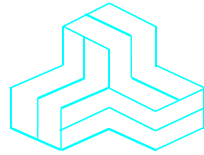

Mobexcom
Model No.: MOBEXCOM UHF
FCC ID: LO6-MBXUHF

Applicant: **Futurecom Systems Group Inc.**
3277 Langstaff Road
Concord, Ontario
Canada, L4K 5P8

Tested in Accordance With

Federal Communications Commission (FCC)
CFR 47, PARTS 2 and 90 (Subpart I)

UltraTech's File No.: FSG27-FTX

This Test report is Issued under the Authority of
Tri M. Luu, Professional Engineer,
Vice President of Engineering
UltraTech Group of Labs

Date: March 23, 2001



Report Prepared by: Dan Huynh

Tested by: Mr. Hung Trinh, RFI/EMI Technicain

Issued Date: March 23, 2001

Test Dates: June 5, 2000
January 17 & 28, 2001

The results in this Test Report apply only to the sample(s) tested, and the sample tested is randomly selected.

UltraTech

3000 Bristol Circle, Oakville, Ontario, Canada, L6H 6G4
Telephone (905) 829-1570 Facsimile (905) 829-8050

Website: www.ultratech-labs.com Email: vhk.ultratech@sympatico.ca

TABLE OF CONTENTS

EXHIBIT 1. SUBMITTAL CHECK LIST	1
EXHIBIT 2. INTRODUCTION.....	2
2.1. SCOPE.....	2
2.2. RELATED SUBMITAL(S)/GRANT(S).....	2
2.3. NORMATIVE REFERENCES.....	2
EXHIBIT 3. PERFORMANCE ASSESSMENT	3
3.1. CLIENT INFORMATION.....	3
3.2. EQUIPMENT UNDER TEST (EUT) INFORMATION	3
3.3. EUT'S TECHNICAL SPECIFICATIONS	4
3.4. LIST OF EUT'S PORTS.....	5
3.5. ANCILLARY EQUIPMENT	5
EXHIBIT 4. EUT OPERATING CONDITIONS AND CONFIGURATIONS DURING TESTS.....	6
4.1. CLIMATE TEST CONDITIONS	6
4.2. OPERATIONAL TEST CONDITIONS & ARRANGEMENT FOR TEST SIGNALS	6
EXHIBIT 5. SUMMARY OF TEST RESULTS.....	7
5.1. LOCATION OF TESTS	7
5.2. APPLICABILITY & SUMMARY OF EMC EMISSION TEST RESULTS	7
5.3. MODIFICATIONS INCORPORATED IN THE EUT FOR COMPLIANCE PURPOSES	7
EXHIBIT 6. MEASUREMENTS, EXAMINATIONS & TEST DATA FOR EMC EMISSIONS	8
6.1. TEST PROCEDURES.....	8
6.2. MEASUREMENT UNCERTAINTIES.....	8
6.3. MEASUREMENT EQUIPMENT USED:	8
6.4. ESSENTIAL/PRIMARY FUNCTIONS AS DECLARED BY THE MANUFACTURER:.....	8
6.5. RF POWER OUTPUT @ FCC 2.1046 & 90.205	9
6.5.1. <i>Limits @ FCC 90.205</i>	9
6.5.2. <i>Method of Measurements</i>	9
6.5.3. <i>Test Equipment List</i>	9
6.5.4. <i>Test Arrangement</i>	9
6.5.5. <i>Test Data</i>	9
6.6. FREQUENCY STABILITY @ FCC 2.1055 & 90.213	10
6.6.1. <i>Limits @ FCC 90.213</i>	10
6.6.2. <i>Method of Measurements</i>	10
6.6.3. <i>Test Equipment List</i>	10
6.6.4. <i>Test Arrangement</i>	10
6.6.5. <i>Test Data</i>	11
6.7. AUDIO FREQUENCY RESPONSE @ FCC 2.1047(A) & 90.242(B)(8).....	15
6.7.1. <i>Limits @ FCC 2.1047(a) and 90.242(b)(8)</i>	15
6.7.2. <i>Method of Measurements</i>	15

ULTRATECH GROUP OF LABS

3000 Bristol Circle, Oakville, Ontario, Canada L6H 6G4
Tel. #: 905-829-1570, Fax. #: 905-829-8050, Email: vhk.ultratech@sympatico.ca, Website: <http://www.ultratech-labs.com>

File #: FSG27-FTX
March 23, 2001

- Assessed by ITI (UK) Competent Body, NVLAP (USA) Accreditation Body & ACA/AUSTEL (Australia)
- Recognized/Listed by FCC (USA), Industry Canada (Canada)
- All test results contained in this engineering test report are traceable to National Institute of Standards and Technology (NIST)

6.7.3.	Test Equipment List.....	15
6.7.4.	Test Arrangement.....	16
6.7.5.	Test Data.....	17
6.8.	MODULATION LIMITING @ FCC 2.1047(B) & 90.210.....	21
6.8.1.	Limits @ FCC 2.1047(b) and 90.210.....	21
6.8.2.	Method of Measurements.....	21
6.8.3.	Test Equipment List.....	21
6.8.4.	Test Arrangement.....	21
6.8.5.	Test Data.....	22
	VOICE MODULATION LIMITING.....	22
6.9.	EMISSION MASK @ FCC 2.1049, 90.208 & 90.210.....	26
6.9.1.	Limits @ FCC 90.209 & 90.210.....	26
6.9.2.	Method of Measurements.....	26
6.9.3.	Test Equipment List.....	26
6.9.4.	Test Arrangement.....	26
6.9.5.	Test Data.....	26
6.10.	TRANSMITTER ANTENNA POWER SPURIOUS/HARMONIC CONDUCTED EMISSIONS @ FCC 90.210.....	27
6.10.1.	Limits @ 90.210.....	27
6.10.2.	Method of Measurements.....	27
6.10.3.	Test Equipment List.....	27
6.10.4.	Test Arrangement.....	27
6.10.5.	Test Data.....	28
6.11.	TRANSMITTER SPURIOUS/HARMONIC RADIATED EMISSIONS @ FCC 90.210.....	30
6.11.1.	Limits @ FCC 90.210.....	30
6.11.2.	Method of Measurements.....	30
6.11.3.	Test Equipment List.....	30
6.11.4.	Test Arrangement.....	31
6.11.5.	Test Data.....	32
6.12.	TRANSIENT FREQUENCY BEHAVIOR @ 90.214.....	36
6.12.1.	Limits.....	36
6.12.2.	Method of Measurements.....	36
6.12.3.	Test Equipment List.....	37
6.12.4.	Test Arrangement.....	37
6.12.5.	Test Data.....	38
EXHIBIT 7.	MEASUREMENT UNCERTAINTY.....	40
7.1.	RADIATED EMISSION MEASUREMENT UNCERTAINTY.....	40
EXHIBIT 8.	MEASUREMENT METHODS.....	41
8.1.	FREQUENCY STABILITY.....	41
8.2.	EMISSION MASK.....	42
8.3.	SPURIOUS EMISSIONS (CONDUCTED).....	42
8.4.	SPURIOUS EMISSIONS (RADIATED).....	43
8.5.	TRANSIENT FREQUENCY BEHAVIOR.....	45
EXHIBIT 9.	TEST DATA PLOTS.....	46
EXHIBIT 10.	TEST SETUP PHOTOS.....	47

ULTRATECH GROUP OF LABS

3000 Bristol Circle, Oakville, Ontario, Canada L6H 6G4
Tel. #: 905-829-1570, Fax. #: 905-829-8050, Email: vhk.ultratech@sympatico.ca, Website: <http://www.ultratech-labs.com>

File #: FSG27-FTX
March 23, 2001

- Assessed by ITI (UK) Competent Body, NVLAP (USA) Accreditation Body & ACA/AUSTEL (Australia)
- Recognized/Listed by FCC (USA), Industry Canada (Canada)
- All test results contained in this engineering test report are traceable to National Institute of Standards and Technology (NIST)

EXHIBIT 11.	EXTERNAL PHOTOS OF EUT	48
EXHIBIT 12.	INTERNAL PHOTOS OF EUT	49
EXHIBIT 13.	COVER LETTERS	50
EXHIBIT 14.	ATTESTATION STATEMENTS.....	51
EXHIBIT 15.	ID LABEL AND LOCATION INFO.....	52
EXHIBIT 16.	BLOCK DIAGRAM	53
EXHIBIT 17.	SCHEMATIC DIAGRAMS	54
EXHIBIT 18.	PARTS LIST/TUNE UP INFO	55
EXHIBIT 19.	OPERATIONAL DESCRIPTION	56
EXHIBIT 20.	RF EXPOSURE INFO.....	57
EXHIBIT 21.	USER'S MANUAL.....	58

ULTRATECH GROUP OF LABS

3000 Bristol Circle, Oakville, Ontario, Canada L6H 6G4
Tel. #: 905-829-1570, Fax. #: 905-829-8050, Email: vhk.ultratech@sympatico.ca, Website: <http://www.ultratech-labs.com>

File #: FSG27-FTX
March 23, 2001

- Assessed by ITI (UK) Competent Body, NVLAP (USA) Accreditation Body & ACA/AUSTEL (Australia)
- Recognized/Listed by FCC (USA), Industry Canada (Canada)
- *All test results contained in this engineering test report are traceable to National Institute of Standards and Technology (NIST)*

EXHIBIT 1. SUBMITTAL CHECK LIST

Exhibit No.	Exhibit Type	Description of Contents	Quality Check (OK)
1 through 8	Test Report	<ul style="list-style-type: none"> • Exhibit 1: Submittal check lists • Exhibit 2: Introduction • Exhibit 3: Performance Assessment • Exhibit 4: EUT Operation and Configuration during Tests • Exhibit 5: Summary of test Results • Exhibit 6: Measurement Data • Exhibit 7: Measurement Uncertainty • Exhibit 8: Measurement Methods 	OK
9	Test Data Plots	- 99% Occupied Bandwidth (Plots # 1 - 6) - Emission Mask B and D (Plots # 7 – 24) - Transmitter Antenna Power Conducted Emissions (Plots # 25 – 30) - Transient Frequency Behavior (Plots # 31 – 34)	OK
10	Test Setup Photos	Radiated Emissions Test Setup Photos	OK
11	External Photos of EUT	External EUT Photos	OK
12	Internal Photos of EUT	Internal EUT Photos	OK
13	Cover Letters	- Letter from Ultratech for Certification Request - Letter from the Applicant to appoint Ultratech to act as an agent - Letter from the Applicant to request for Confidentiality Filing	OK
14	Attestation Statements	406 – 406.125 MHz exclusion band attestation statements.	OK
15	ID Label/Location Info	ID Label Location of ID Label	OK
16	Block Diagrams	MOBEXCOM UHF Block Diagram 8D073A16	OK
17	Schematic Diagrams	MOBEXCOM UHF PA Schematic 8D073B04	OK
18	Parts List/Tune Up Info	--	--
19	Operational Description	MOBEXCOM Brief Description	OK
20	RF Exposure Info	Refer to pages 3 – 4 in the User's Manual	OK
21	Users Manual	Vehicular Repeater User's Manual 8A073X02 Rev-Preliminary	OK

ULTRATECH GROUP OF LABS

3000 Bristol Circle, Oakville, Ontario, Canada L6H 6G4
 Tel. #: 905-829-1570, Fax. #: 905-829-8050, Email: vhk.ultratech@sympatico.ca, Website: <http://www.ultratech-labs.com>

File #: FSG27-FTX
 March 23, 2001

- Assessed by ITI (UK) Competent Body, NVLAP (USA) Accreditation Body & ACA/AUSTEL (Australia)
- Recognized/Listed by FCC (USA), Industry Canada (Canada)
- All test results contained in this engineering test report are traceable to National Institute of Standards and Technology (NIST)

EXHIBIT 2. INTRODUCTION

2.1. SCOPE

Reference:	FCC Parts 2 and 90
Title:	Telecommunication - Code of Federal Regulations, CFR 47, Parts 2 & 90
Purpose of Test:	To gain FCC Certification Authorization for Radio operating in the frequency band 403 - 512 MHz (12.5 kHz and 25 kHz Channel Spacings).
Test Procedures:	Both conducted and radiated emissions measurements were conducted in accordance with American National Standards Institute ANSI C63.4 - American National Standard for Methods of Measurement of Radio-Noise Emissions from Low-Voltage Electrical and Electronic Equipment in the Range of 9 kHz to 40 GHz.

2.2. RELATED SUBMITAL(S)/GRANT(S)

None

2.3. NORMATIVE REFERENCES

Publication	Year	Title
FCC CFR Parts 0-19, 80-End	1998	Code of Federal Regulations – Telecommunication
ANSI C63.4	1992	American National Standard for Methods of Measurement of Radio-Noise Emissions from Low-Voltage Electrical and Electronic Equipment in the Range of 9 kHz to 40 GHz
CISPR 22 & EN 55022	1997 1998	Limits and Methods of Measurements of Radio Disturbance Characteristics of Information Technology Equipment
CISPR 16-1		Specification for Radio Disturbance and Immunity measuring apparatus and methods

ULTRATECH GROUP OF LABS

3000 Bristol Circle, Oakville, Ontario, Canada L6H 6G4
Tel. #: 905-829-1570, Fax. #: 905-829-8050, Email: vhk.ultratech@sympatico.ca, Website: <http://www.ultratech-labs.com>

File #: FSG27-FTX
March 23, 2001

- Assessed by ITI (UK) Competent Body, NVLAP (USA) Accreditation Body & ACA/AUSTEL (Australia)
- Recognized/Listed by FCC (USA), Industry Canada (Canada)
- All test results contained in this engineering test report are traceable to National Institute of Standards and Technology (NIST)

EXHIBIT 3. PERFORMANCE ASSESSMENT

3.1. CLIENT INFORMATION

APPLICANT	
Name:	Futurecom Systems Group Inc.
Address:	3277 Langstaff Rd Concord, Ontario Canada, L4K 5P8
Contact Person:	Mr Adam J. Kolanski Phone #: 905-660-5548 x 270 Fax #: 905-660-6858 Email Address: adamk@futurecom.com

MANUFACTURER	
Name:	Futurecom Systems Group Inc.
Address:	3277 Langstaff Rd Concord, Ontario Canada, L4K 5P8
Contact Person:	Mr Adam J. Kolanski Phone #: 905-660-5548 x 270 Fax #: 905-660-6858 Email Address: adamk@futurecom.com

3.2. EQUIPMENT UNDER TEST (EUT) INFORMATION

The following information (with the exception of the Date of Receipt) has been supplied by the applicant.

Brand Name:	Futurecom Systems Group Inc.
Product Name:	Mobexcom
Model Name or Number:	MOBEXCOM UHF
Serial Number:	Pre-production
Type of Equipment:	Radio Communication Equipment
External Power Supply:	N/A
Transmitting/Receiving Antenna Type:	Non-integral
Primary User Functions of EUT:	Vehicular repeater – provides coverage extension for portable radios

ULTRATECH GROUP OF LABS

3000 Bristol Circle, Oakville, Ontario, Canada L6H 6G4
 Tel. #: 905-829-1570, Fax. #: 905-829-8050, Email: vhk.ultratech@sympatico.ca, Website: <http://www.ultratech-labs.com>

File #: FSG27-FTX
 March 23, 2001

- Assessed by ITI (UK) Competent Body, NVLAP (USA) Accreditation Body & ACA/AUSTEL (Australia)
- Recognized/Listed by FCC (USA), Industry Canada (Canada)
- All test results contained in this engineering test report are traceable to National Institute of Standards and Technology (NIST)

3.3. EUT'S TECHNICAL SPECIFICATIONS

TRANSMITTER	
Equipment Type:	<input type="checkbox"/> Portable <input checked="" type="checkbox"/> Mobile <input type="checkbox"/> Base station (fixed use)
Intended Operating Environment:	<input type="checkbox"/> Commercial <input checked="" type="checkbox"/> Light Industry & Heavy Industry
Power Supply Requirement:	13.8 Vdc
RF Output Power Rating:	15 Watts
Operating Frequency Range:	403 - 512 MHz
RF Output Impedance:	50 Ohms
Channel Spacing:	12.5 kHz and 25 kHz
*Occupied Bandwidth (99%):	10.0 kHz (12.5 kHz Channel Spacing) 14.5 kHz (25 kHz Channel Spacing)
**Emission Designation:	11K0F3E, 16K0F3E
Digital Oscillator Frequencies:	16.0, 29.4912, 32.768, 93.6, 96.0 MHz
Radio Oscillator Frequencies:	Rx + 109.65, 109.2, Tx + 110.51875 MHz
Antenna Connector Type:	TNC Female

* Refer to Exhibit 9 test data plots 1 to 6 for details.

* *For an average case of commercial telephony, the Necessary Bandwidth are calculated as follows:

For FM Voice Modulation:

Channel Spacing = 12.5 KHz, D = 2.4 KHz max., K = 1, M = 3 KHz

$$B_n = 2M + 2DK = 2(3) + 2(2.4)(1) = \mathbf{11\ KHz}$$

Emission Designation: 11K0F3E

Channel Spacing = 25 KHz, D = 4.9 KHz max., K = 1, M = 3 KHz

$$B_n = 2M + 2DK = 2(3) + 2(4.9)(1) = \mathbf{16\ KHz}$$

Emission Designation: 16K0F3E

ULTRATECH GROUP OF LABS

3000 Bristol Circle, Oakville, Ontario, Canada L6H 6G4
 Tel. #: 905-829-1570, Fax. #: 905-829-8050, Email: vhk.ultratech@sympatico.ca, Website: <http://www.ultratech-labs.com>

File #: FSG27-FTX
 March 23, 2001

- Assessed by ITI (UK) Competent Body, NVLAP (USA) Accreditation Body & ACA/AUSTEL (Australia)
- Recognized/Listed by FCC (USA), Industry Canada (Canada)
- All test results contained in this engineering test report are traceable to National Institute of Standards and Technology (NIST)

3.4. LIST OF EUT'S PORTS

Port Number	EUT's Port Description	Number of Identical Ports	Connector Type	Cable Type (Shielded/Non-shielded)
1	Transmitter	1	SMA	Terminated with 50 Ohms load
2	Receiver	1	SMA	Terminated with 50 Ohms load
3	Antenna	1	TNC	Terminated with 50 Ohms load
4	Switching Plate Connector	2	SMA	Terminated with 50 Ohms load
5	Power	1	4-pin	Non-shielded
6	RS232	1	DB9	Shielded
7	Mobile Radio Control	2	DB25	Shielded

NOTES:

- (1) **Ports of the EUT which in normal operation were connected to ancillary equipment through interconnecting cables via a representative interconnecting cable to simulate the input/output characteristics. RF input/output was correctly terminated to the 50 Ohms RF Load.**
- (2) **Ports, which are not connected to cables during normal intended operation (for factory/technical services uses only): None.**

3.5. ANCILLARY EQUIPMENT

The EUT was tested while connected to the following representative configuration of ancillary equipment necessary to exercise the ports during tests:

Ancillary Equipment # 1	
Description:	IBM ThinkPad
Brand name:	IBM
FCC ID:	ANOKAJIPENCP
Serial Number:	1S2625DEF78WWM48
Connected to EUT's Port:	RS232

ULTRATECH GROUP OF LABS

3000 Bristol Circle, Oakville, Ontario, Canada L6H 6G4
 Tel. #: 905-829-1570, Fax. #: 905-829-8050, Email: vhk.ultratech@sympatico.ca, Website: <http://www.ultratech-labs.com>

File #: FSG27-FTX
 March 23, 2001

- Assessed by ITI (UK) Competent Body, NVLAP (USA) Accreditation Body & ACA/AUSTEL (Australia)
- Recognized/Listed by FCC (USA), Industry Canada (Canada)
- All test results contained in this engineering test report are traceable to National Institute of Standards and Technology (NIST)

EXHIBIT 4. EUT OPERATING CONDITIONS AND CONFIGURATIONS DURING TESTS

4.1. CLIMATE TEST CONDITIONS

The climate conditions of the test environment are as follows:

Temperature:	21°C
Humidity:	51%
Pressure:	102 kPa
Power input source:	+13.8 Vdc

4.2. OPERATIONAL TEST CONDITIONS & ARRANGEMENT FOR TEST SIGNALS

Operating Modes:	The transmitter was operated in a continuous transmission mode with the carrier modulated as specified in the Test Data.
Special Test Software:	Testing software provided by the manufacturer to configure different test configuration.
Special Hardware Used:	None.
Transmitter Test Antenna:	The EUT is tested with the transmitter antenna port terminated to a 50 Ohms RF Load.

Transmitter Test Signals	
Frequency Band(s): <ul style="list-style-type: none"> ▪ 403 - 512 MHz band: 	Near lowest, near middle & near highest frequencies in each frequency bands that the transmitter covers: <ul style="list-style-type: none"> ▪ 406.125 MHz, 450 MHz and 470 MHz
Transmitter Wanted Output Test Signals: <ul style="list-style-type: none"> ▪ RF Power Output (measured maximum output power): ▪ Normal Test Modulation ▪ Modulating signal source: 	<ul style="list-style-type: none"> ▪ 15 Watts ▪ FM with 2.5 kHz sine wave ▪ External

ULTRATECH GROUP OF LABS

3000 Bristol Circle, Oakville, Ontario, Canada L6H 6G4
 Tel. #: 905-829-1570, Fax. #: 905-829-8050, Email: vhk.ultratech@sympatico.ca, Website: <http://www.ultratech-labs.com>

File #: FSG27-FTX
 March 23, 2001

- Assessed by ITI (UK) Competent Body, NVLAP (USA) Accreditation Body & ACA/AUSTEL (Australia)
- Recognized/Listed by FCC (USA), Industry Canada (Canada)
- All test results contained in this engineering test report are traceable to National Institute of Standards and Technology (NIST)

EXHIBIT 5. SUMMARY OF TEST RESULTS

5.1. LOCATION OF TESTS

All of the measurements described in this report were performed at Ultratech Group of Labs located in the city of Oakville, Province of Ontario, Canada.

Radiated Emissions were performed at the Ultratech's 3 Meter Open Field Test Site (OFTS) situated in the Town of Oakville, province of Ontario.

The above site have been calibrated in accordance with ANSI C63.4, and found to be in compliance with the requirements of Sec. 2.948 of the FCC Rules. The descriptions and site measurement data of the Oakville Open Field Test Site has been filed with FCC office (FCC File No.: 31040/SIT 1300B3) and Industry Canada office (Industry Canada File No.: IC2049). Last Date of Site Calibration: Sep. 20, 1999.

5.2. APPLICABILITY & SUMMARY OF EMC EMISSION TEST RESULTS

FCC PARAGRAPH.	TEST REQUIREMENTS	APPLICABILITY (YES/NO)
90.205 & 2.1046	RF Power Output	Yes
90.213 & 2.1055	Frequency Stability	Yes
90.242(b)(8) & 2.1047(a)	Audio Frequency Response	Not applicable to new standard. However, tests are conducted under FCC's recommendation.
90.210 & 2.1047(b)	Modulation Limiting	Yes
90.209 90.210 & 2.1049	Emission Limitation & Emission Mask	Yes
90.210, 2.1057 & 2.1051	Emission Limits - Spurious Emissions at Antenna Terminal	Yes
90.210, 2.1057 & 2.1053	Emission Limits - Field Strength of Spurious Emissions	Yes
90.214	Transient Frequency Behavior	Yes
Mobexcom, Model No.: MOBEXCOM UHF, by Futurecom Systems Group Inc. has also been tested and found to comply with FCC Part 15, Subpart B - Radio Receivers and Class A Digital Devices. The engineering test report has been documented and kept in file and it is available anytime upon FCC request.		

5.3. MODIFICATIONS INCORPORATED IN THE EUT FOR COMPLIANCE PURPOSES

None

ULTRATECH GROUP OF LABS

3000 Bristol Circle, Oakville, Ontario, Canada L6H 6G4
Tel. #: 905-829-1570, Fax. #: 905-829-8050, Email: vhk.ultratech@sympatico.ca, Website: <http://www.ultratech-labs.com>

File #: FSG27-FTX
March 23, 2001

- Assessed by ITI (UK) Competent Body, NVLAP (USA) Accreditation Body & ACA/AUSTEL (Australia)
- Recognized/Listed by FCC (USA), Industry Canada (Canada)
- All test results contained in this engineering test report are traceable to National Institute of Standards and Technology (NIST)

EXHIBIT 6. MEASUREMENTS, EXAMINATIONS & TEST DATA FOR EMC EMISSIONS

6.1. TEST PROCEDURES

This section contains test results only. Details of test methods and procedures can be found in Exhibit 8 of this report

6.2. MEASUREMENT UNCERTAINTIES

The measurement uncertainties stated were calculated in accordance with requirements of UKAS Document NIS 81 with a confidence level of 95%. Please refer to Exhibit 7 for Measurement Uncertainties.

6.3. MEASUREMENT EQUIPMENT USED:

The measurement equipment used complied with the requirements of the Standards referenced in the Methods & Procedures ANSI C63.4:1992 and CISPR 16-1.

6.4. ESSENTIAL/PRIMARY FUNCTIONS AS DECLARED BY THE MANUFACTURER:

The essential function of the EUT is to correctly communicate data to and from radios over RF link.

ULTRATECH GROUP OF LABS

3000 Bristol Circle, Oakville, Ontario, Canada L6H 6G4
Tel. #: 905-829-1570, Fax. #: 905-829-8050, Email: vhk.ultratech@sympatico.ca, Website: <http://www.ultratech-labs.com>

File #: FSG27-FTX
March 23, 2001

- Assessed by ITI (UK) Competent Body, NVLAP (USA) Accreditation Body & ACA/AUSTEL (Australia)
- Recognized/Listed by FCC (USA), Industry Canada (Canada)
- *All test results contained in this engineering test report are traceable to National Institute of Standards and Technology (NIST)*

6.5. RF POWER OUTPUT @ FCC 2.1046 & 90.205

6.5.1. Limits @ FCC 90.205

Please refer to FCC CFR 47, Part 90, Subpart I, Para. 90.205 for specification details.

6.5.2. Method of Measurements

- The transmitter terminal was coupled to the Spectrum Analyzer through a 20 dB attenuator
- Power of the transmitter channel near the lowest, middle and highest of each frequency block/band were measured using the power meter, and the reading was corrected by added the calibrated attenuator's attenuation value and cable loss.
- The RF Output was turned on with standard modulation applied.

6.5.3. Test Equipment List

Test Instruments	Manufacturer	Model No.	Serial No.	Frequency Range
Power Meter	Hewlett Packard	436A	1725A02249	10 kHz – 50 GHz, sensor dependent
Power Sensor	Hewlett Packard	8481A	2702A68983	10 MHz – 18 GHz
Attenuator(s)	Weinschel Corp	24-20-34	BJ2357	DC – 8.5 GHz

6.5.4. Test Arrangement

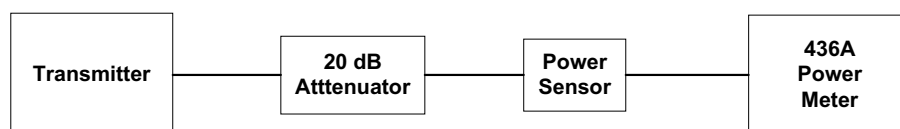

6.5.5. Test Data

Transmitter Channel Output	Fundamental Frequency (MHz)	Measured Power (dBm)	Power Rating (dBm)
Lowest	406.125	41.80	41.76
Middle	450	41.40	41.76
Highest	470	41.40	41.76

ULTRATECH GROUP OF LABS

3000 Bristol Circle, Oakville, Ontario, Canada L6H 6G4
 Tel. #: 905-829-1570, Fax. #: 905-829-8050, Email: vhk.ultratech@sympatico.ca, Website: <http://www.ultratech-labs.com>

File #: FSG27-FTX
 March 23, 2001

- Assessed by ITI (UK) Competent Body, NVLAP (USA) Accreditation Body & ACA/AUSTEL (Australia)
- Recognized/Listed by FCC (USA), Industry Canada (Canada)
- All test results contained in this engineering test report are traceable to National Institute of Standards and Technology (NIST)

6.6. FREQUENCY STABILITY @ FCC 2.1055 & 90.213

6.6.1. Limits @ FCC 90.213

Please refer to FCC CFR 47, Part 90, Subpart I, Para. 90.213 for specification details.

FREQUENCY RANGE (MHz)	FIXED & BASE STATIONS (ppm)			MOBILE STATIONS (ppm)					
				> 2 W			≤ 2 W		
	6.25 kHz	12.5 kHz	25 kHz	6.25 kHz	12.5 kHz	25 kHz	6.25 kHz	12.5 kHz	25 kHz
403-512 MHz	0.5	1.5	2.5	1.0	2.5	5.0	1.0	2.5	5.0

6.6.2. Method of Measurements

Refer to Exhibit 8 section 8.1 of this report for measurement details

6.6.3. Test Equipment List

Test Instruments	Manufacturer	Model No.	Serial No.	Frequency Range
Spectrum Analyzer/EMI Receiver	Advantest	R3271	15050203	100 Hz – 26.5 GHz
Attenuator(s)	Bird	DC – 22 GHz
Temperature & Humidity Chamber	Tenney	T5	9723B	-40° to +60° C range

6.6.4. Test Arrangement

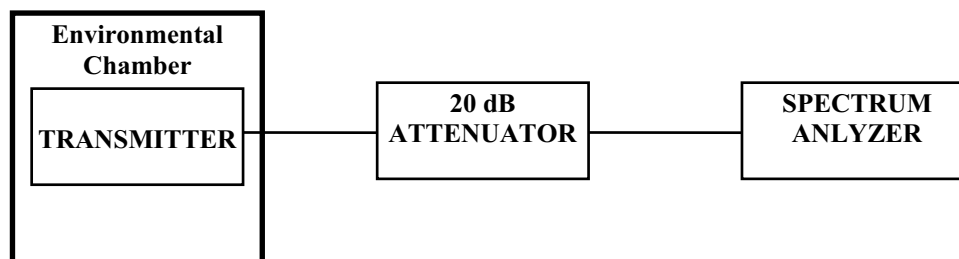

ULTRATECH GROUP OF LABS

3000 Bristol Circle, Oakville, Ontario, Canada L6H 6G4
 Tel. #: 905-829-1570, Fax. #: 905-829-8050, Email: vhk.ultratech@sympatico.ca, Website: <http://www.ultratech-labs.com>

File #: FSG27-FTX
 March 23, 2001

- Assessed by ITI (UK) Competent Body, NVLAP (USA) Accreditation Body & ACA/AUSTEL (Australia)
- Recognized/Listed by FCC (USA), Industry Canada (Canada)
- All test results contained in this engineering test report are traceable to National Institute of Standards and Technology (NIST)

6.6.5. Test Data

Product Name:	Mobexcom
Model No.:	MOBEXCOM UHF
Center Frequency:	406.125 MHz
Full Power Level:	15 Watts
Frequency Tolerance Limit:	2.5 ppm or 1015 Hz at 406.125 MHz
Max. Frequency Tolerance Measured:	-428 Hz or 1.1 ppm
Input Voltage Rating:	+13.8 Vdc

CENTER FREQUENCY & RF POWER OUTPUT VARIATION							
Ambient Temperature (°C)	Keyed-On Time (Minutes)	Supply Voltage (Nominal) 13.8 Vdc		Supply Voltage (85% of Nominal) 11.73 Vdc		Supply Voltage (115% of Nominal) 15.87 Vdc	
		Hz	dB	Hz	dB	Hz	dB
-30	0	-397	N/A	N/A	N/A	N/A	N/A
	1	-406	N/A	N/A	N/A	N/A	N/A
	2	-403	N/A	N/A	N/A	N/A	N/A
	3	-406	N/A	N/A	N/A	N/A	N/A
	4	-417	N/A	N/A	N/A	N/A	N/A
	5	-420	N/A	N/A	N/A	N/A	N/A
	6	-428	N/A	N/A	N/A	N/A	N/A
	7	-426	N/A	N/A	N/A	N/A	N/A
	8	-428	N/A	N/A	N/A	N/A	N/A
	9	-428	N/A	N/A	N/A	N/A	N/A
	10	-428	N/A	N/A	N/A	N/A	N/A
-20	0	-286	N/A	N/A	N/A	N/A	N/A
	1	-266	N/A	N/A	N/A	N/A	N/A
	2	-280	N/A	N/A	N/A	N/A	N/A
	3	-288	N/A	N/A	N/A	N/A	N/A
	4	-280	N/A	N/A	N/A	N/A	N/A
	5	-283	N/A	N/A	N/A	N/A	N/A
	6	-286	N/A	N/A	N/A	N/A	N/A
	7	-274	N/A	N/A	N/A	N/A	N/A
	8	-274	N/A	N/A	N/A	N/A	N/A
	9	-279	N/A	N/A	N/A	N/A	N/A
	10	-281	N/A	N/A	N/A	N/A	N/A

ULTRATECH GROUP OF LABS

3000 Bristol Circle, Oakville, Ontario, Canada L6H 6G4
 Tel. #: 905-829-1570, Fax. #: 905-829-8050, Email: vhk.ultratech@sympatico.ca, Website: <http://www.ultratech-labs.com>

File #: FSG27-FTX
 March 23, 2001

- Assessed by ITI (UK) Competent Body, NVLAP (USA) Accreditation Body & ACA/AUSTEL (Australia)
- Recognized/Listed by FCC (USA), Industry Canada (Canada)
- All test results contained in this engineering test report are traceable to National Institute of Standards and Technology (NIST)

CENTER FREQUENCY & RF POWER OUTPUT VARIATION							
Ambient Temperature (°C)	Keyed-On Time (Minutes)	Supply Voltage (Nominal) 13.8 Vdc		Supply Voltage (85% of Nominal) 11.73 Vdc		Supply Voltage (115% of Nominal) 15.87 Vdc	
		Hz	dB	Hz	dB	Hz	dB
-10	0	-88	N/A	N/A	N/A	N/A	N/A
	1	-91	N/A	N/A	N/A	N/A	N/A
	2	-88	N/A	N/A	N/A	N/A	N/A
	3	-103	N/A	N/A	N/A	N/A	N/A
	4	-91	N/A	N/A	N/A	N/A	N/A
	5	-86	N/A	N/A	N/A	N/A	N/A
	6	-100	N/A	N/A	N/A	N/A	N/A
	7	-91	N/A	N/A	N/A	N/A	N/A
	8	-91	N/A	N/A	N/A	N/A	N/A
	9	-83	N/A	N/A	N/A	N/A	N/A
10	-82	N/A	N/A	N/A	N/A	N/A	
0	0	-6	N/A	N/A	N/A	N/A	N/A
	1	-3	N/A	N/A	N/A	N/A	N/A
	2	-6	N/A	N/A	N/A	N/A	N/A
	3	-3	N/A	N/A	N/A	N/A	N/A
	4	-14	N/A	N/A	N/A	N/A	N/A
	5	-8	N/A	N/A	N/A	N/A	N/A
	6	-6	N/A	N/A	N/A	N/A	N/A
	7	+3	N/A	N/A	N/A	N/A	N/A
	8	-3	N/A	N/A	N/A	N/A	N/A
	9	0	N/A	N/A	N/A	N/A	N/A
10	-1	N/A	N/A	N/A	N/A	N/A	
+10	0	-8	N/A	N/A	N/A	N/A	N/A
	1	-11	N/A	N/A	N/A	N/A	N/A
	2	-6	N/A	N/A	N/A	N/A	N/A
	3	-6	N/A	N/A	N/A	N/A	N/A
	4	-6	N/A	N/A	N/A	N/A	N/A
	5	+3	N/A	N/A	N/A	N/A	N/A
	6	-3	N/A	N/A	N/A	N/A	N/A
	7	+6	N/A	N/A	N/A	N/A	N/A
	8	+12	N/A	N/A	N/A	N/A	N/A
	9	+3	N/A	N/A	N/A	N/A	N/A
10	+4	N/A	N/A	N/A	N/A	N/A	

ULTRATECH GROUP OF LABS

3000 Bristol Circle, Oakville, Ontario, Canada L6H 6G4
 Tel. #: 905-829-1570, Fax. #: 905-829-8050, Email: vhk.ultratech@sympatico.ca, Website: <http://www.ultratech-labs.com>

File #: FSG27-FTX
 March 23, 2001

- Assessed by ITI (UK) Competent Body, NVLAP (USA) Accreditation Body & ACA/AUSTEL (Australia)
- Recognized/Listed by FCC (USA), Industry Canada (Canada)
- All test results contained in this engineering test report are traceable to National Institute of Standards and Technology (NIST)

CENTER FREQUENCY & RF POWER OUTPUT VARIATION							
Ambient Temperature (°C)	Keyed-On Time (Minutes)	Supply Voltage (Nominal) 13.8 Vdc		Supply Voltage (85% of Nominal) 11.73 Vdc		Supply Voltage (115% of Nominal) 15.87 Vdc	
		Hz	dB	Hz	DB	Hz	dB
+20	0	-17	+1.9	-46	+17.1	-86	+41.8
	1	-23	+3.9	-60	+20.1	-66	+39.5
	2	-11	+1.2	-60	+21.2	-63	+35.6
	3	-20	+3.9	-57	+18.3	-68	+33.2
	4	-34	+8.1	-46	+13.6	-63	+30.7
	5	-11	+2.5	-60	+21.1	-66	+22.9
	6	-20	+1.9	-54	+23.5	-66	+20.7
	7	-23	+2.3	-57	+16.6	-71	+40.6
	8	-23	+6.4	-60	+19.6	-80	+27.8
	9	-31	+8.6	-57	+24.7	-68	+33.1
	10	-22	+4.2	-56	+19.6	-70	+33.6
+30	0	-166	N/A	N/A	N/A	N/A	N/A
	1	-154	N/A	N/A	N/A	N/A	N/A
	2	-163	N/A	N/A	N/A	N/A	N/A
	3	-160	N/A	N/A	N/A	N/A	N/A
	4	-166	N/A	N/A	N/A	N/A	N/A
	5	-148	N/A	N/A	N/A	N/A	N/A
	6	-166	N/A	N/A	N/A	N/A	N/A
	7	-166	N/A	N/A	N/A	N/A	N/A
	8	-160	N/A	N/A	N/A	N/A	N/A
	9	-160	N/A	N/A	N/A	N/A	N/A
	10	-161	N/A	N/A	N/A	N/A	N/A
+40	0	-231	N/A	N/A	N/A	N/A	N/A
	1	-228	N/A	N/A	N/A	N/A	N/A
	2	-231	N/A	N/A	N/A	N/A	N/A
	3	-243	N/A	N/A	N/A	N/A	N/A
	4	-226	N/A	N/A	N/A	N/A	N/A
	5	-234	N/A	N/A	N/A	N/A	N/A
	6	-237	N/A	N/A	N/A	N/A	N/A
	7	-243	N/A	N/A	N/A	N/A	N/A
	8	-228	N/A	N/A	N/A	N/A	N/A
	9	-231	N/A	N/A	N/A	N/A	N/A
	10	-232	N/A	N/A	N/A	N/A	N/A

ULTRATECH GROUP OF LABS

3000 Bristol Circle, Oakville, Ontario, Canada L6H 6G4
 Tel. #: 905-829-1570, Fax. #: 905-829-8050, Email: vhk.ultratech@sympatico.ca, Website: <http://www.ultratech-labs.com>

File #: FSG27-FTX
 March 23, 2001

- Assessed by ITI (UK) Competent Body, NVLAP (USA) Accreditation Body & ACA/AUSTEL (Australia)
- Recognized/Listed by FCC (USA), Industry Canada (Canada)
- All test results contained in this engineering test report are traceable to National Institute of Standards and Technology (NIST)

CENTER FREQUENCY & RF POWER OUTPUT VARIATION							
Ambient Temperature (°C)	Keyed-On Time (Minutes)	Supply Voltage (Nominal) 13.8 Vdc		Supply Voltage (85% of Nominal) 11.73 Vdc		Supply Voltage (115% of Nominal) 15.87 Vdc	
		Hz	dB	Hz	dB	Hz	dB
+50	0	-328	N/A	N/A	N/A	N/A	N/A
	1	-311	N/A	N/A	N/A	N/A	N/A
	2	-326	N/A	N/A	N/A	N/A	N/A
	3	-323	N/A	N/A	N/A	N/A	N/A
	4	-314	N/A	N/A	N/A	N/A	N/A
	5	-317	N/A	N/A	N/A	N/A	N/A
	6	-323	N/A	N/A	N/A	N/A	N/A
	7	-326	N/A	N/A	N/A	N/A	N/A
	8	-320	N/A	N/A	N/A	N/A	N/A
	9	-323	N/A	N/A	N/A	N/A	N/A
10	-321	N/A	N/A	N/A	N/A	N/A	

ULTRATECH GROUP OF LABS

3000 Bristol Circle, Oakville, Ontario, Canada L6H 6G4
 Tel. #: 905-829-1570, Fax. #: 905-829-8050, Email: vhk.ultratech@sympatico.ca, Website: <http://www.ultratech-labs.com>

File #: FSG27-FTX
 March 23, 2001

- Assessed by ITI (UK) Competent Body, NVLAP (USA) Accreditation Body & ACA/AUSTEL (Australia)
- Recognized/Listed by FCC (USA), Industry Canada (Canada)
- All test results contained in this engineering test report are traceable to National Institute of Standards and Technology (NIST)

6.7. AUDIO FREQUENCY RESPONSE @ FCC 2.1047(a) & 90.242(b)(8)

6.7.1. Limits @ FCC 2.1047(a) and 90.242(b)(8)

No limit is required by FCC for audio frequency response. However, FCC recommends the Audio Frequency Response to be tested to show the roll-off curve at 3 kHz.

Recommended Limits: The attenuation of lowpass filter between the frequencies of 3 KHz and 20 KHz shall be greater than the attenuation at 1KHz by at least: $60\text{Log}_{10}(f/3)$ decibels where "f" is the frequency in KHz. At frequency above 20 KHz, the attenuation shall be 50 dB greater than the attenuation at 1 KHz.

6.7.2. Method of Measurements

The rated audio input signal was applied to the input of the audio lowpass filter (or of all modulation stages) using an audio oscillator, this input signal level and its corresponding output signal were then measured and recorded using the FFT (Audio) spectrum analyzer. Tests were repeated at different audio signal frequencies from 0 to 50 kHz.

6.7.3. Test Equipment List

Test Instruments	Manufacturer	Model No.	Serial No. / PN	Frequency Range
FFT (audio) Spectrum Analyzer	Advantest	R9211E	82020336	10 mHz – 100 kHz, 1 MHz Input Impedance
Communication Analyzer (Test Receiver)	Marconi Instruments	2955	132037/226	400kHz - 1000 MHz
Synthesized Function Generator	Stanford Research Systems	DS345	34591	1μHz – 30.2 MHz

ULTRATECH GROUP OF LABS

3000 Bristol Circle, Oakville, Ontario, Canada L6H 6G4
Tel. #: 905-829-1570, Fax. #: 905-829-8050, Email: vhk.ultratech@sympatico.ca, Website: <http://www.ultratech-labs.com>

File #: FSG27-FTX
March 23, 2001

- Assessed by ITI (UK) Competent Body, NVLAP (USA) Accreditation Body & ACA/AUSTEL (Australia)
- Recognized/Listed by FCC (USA), Industry Canada (Canada)
- All test results contained in this engineering test report are traceable to National Institute of Standards and Technology (NIST)

6.7.4. Test Arrangement

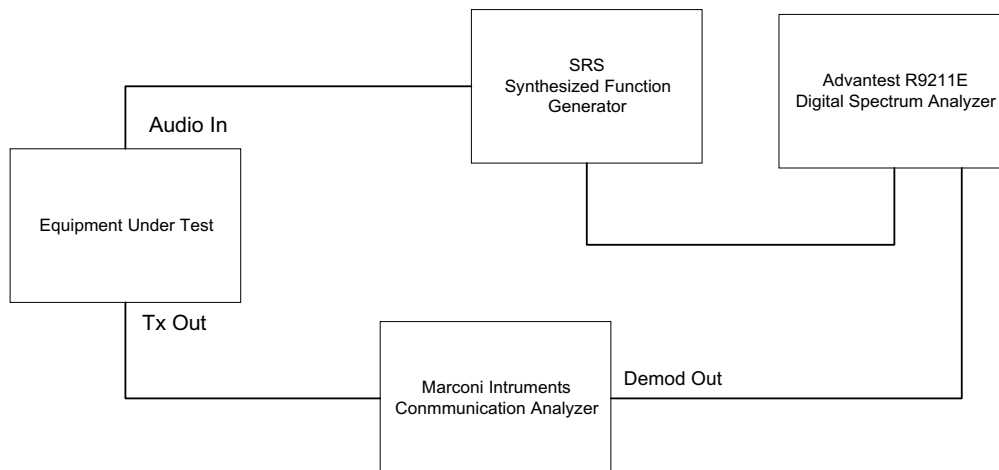

ULTRATECH GROUP OF LABS

3000 Bristol Circle, Oakville, Ontario, Canada L6H 6G4
Tel. #: 905-829-1570, Fax. #: 905-829-8050, Email: vhk.ultratech@sympatico.ca, Website: <http://www.ultratech-labs.com>

File #: FSG27-FTX
March 23, 2001

- Assessed by ITI (UK) Competent Body, NVLAP (USA) Accreditation Body & ACA/AUSTEL (Australia)
- Recognized/Listed by FCC (USA), Industry Canada (Canada)
- All test results contained in this engineering test report are traceable to National Institute of Standards and Technology (NIST)

6.7.5. Test Data

Audio Frequency Response Of A Low Pass Filter / All Modulation States (12.5 kHz Channel Spacing)					
FREQUENCY (kHz)	AUDIO IN (dBV)	AUDIO OUT (dBV)	ATTEN. (OUT - IN) (dB)	ATTEN. wrt. 1 kHz (dB)	FCC LIMIT @ 90.242(b)(8) (dB)
1.00	-15.5	-10.1	5.4	0.0	0.0
2.00	-15.4	-9.6	5.8	0.4	0.0
3.00	-15.2	-10.6	4.6	-0.8	0.0
4.00	-15.5	-20.1	-4.6	-10.0	-7.5
5.00	-15.5	<-61.0	-45.5	-50.9	-13.3
6.00	-15.5	<-90.5	-75.0	-80.4	-18.1
7.00	-15.5	<-90.9	-75.4	-80.8	-22.1
8.00	-15.5	<-95.0	-79.5	-84.9	-25.6
9.00	-15.5	<-95.0	-79.5	-84.9	-28.6
10.00	-15.5	<-95.0	-79.5	-84.9	-31.4
15.00	-15.5	<-95.0	-79.5	-84.9	-41.9
20.00	-15.5	<-95.0	-79.5	-84.9	-50.0
22.00	-15.5	<-95.0	-79.5	-84.9	-50.0
24.00	-15.5	<-95.0	-79.5	-84.9	-50.0
26.00	-15.5	<-95.0	-79.5	-84.9	-50.0
28.00	-15.5	<-95.0	-79.5	-84.9	-50.0
30.00	-15.5	<-95.0	-79.5	-84.9	-50.0
40.00	-15.5	<-95.0	-79.5	-84.9	-50.0
50.00	-15.5	<-95.0	-79.5	-84.9	-50.0

ULTRATECH GROUP OF LABS

3000 Bristol Circle, Oakville, Ontario, Canada L6H 6G4
 Tel. #: 905-829-1570, Fax. #: 905-829-8050, Email: vhk.ultratech@sympatico.ca, Website: <http://www.ultratech-labs.com>

File #: FSG27-FTX
 March 23, 2001

- Assessed by ITI (UK) Competent Body, NVLAP (USA) Accreditation Body & ACA/AUSTEL (Australia)
- Recognized/Listed by FCC (USA), Industry Canada (Canada)
- All test results contained in this engineering test report are traceable to National Institute of Standards and Technology (NIST)

AUDIO FREQUENCY RESPONSE (12.5 kHz Channel Spacing)
Futurecom Systems Group Inc.
Mobexcom, Model MOBEXCOM UHF

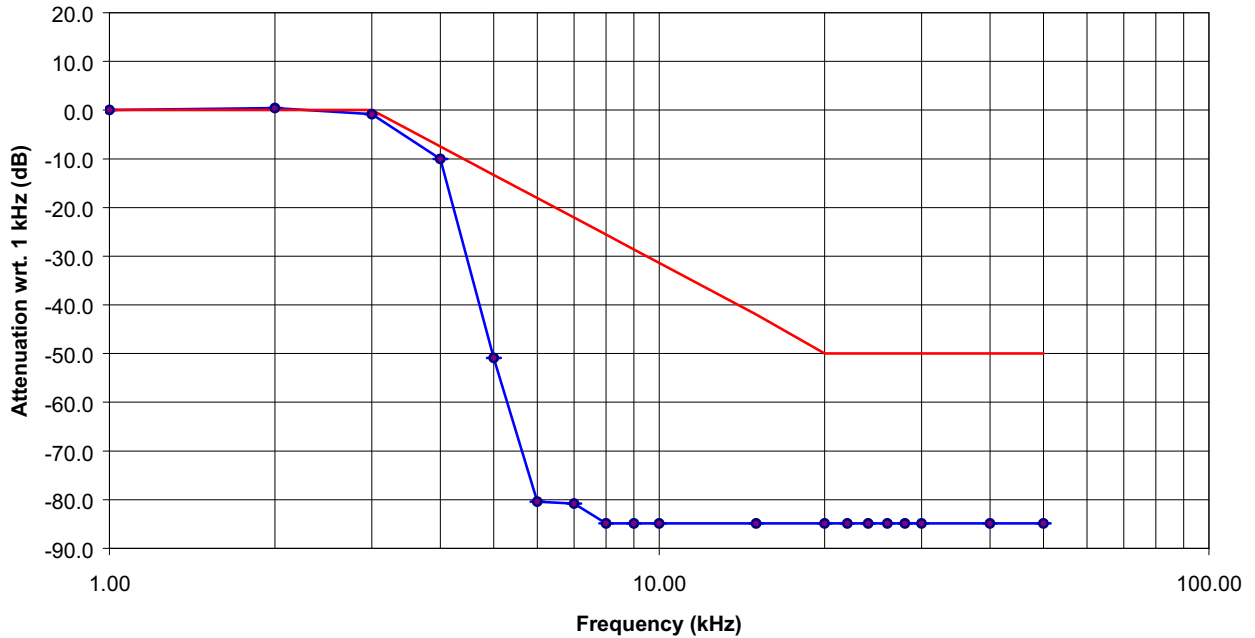

ULTRATECH GROUP OF LABS

3000 Bristol Circle, Oakville, Ontario, Canada L6H 6G4
Tel. #: 905-829-1570, Fax. #: 905-829-8050, Email: vhk.ultratech@sympatico.ca, Website: <http://www.ultratech-labs.com>

File #: FSG27-FTX
March 23, 2001

- Assessed by ITI (UK) Competent Body, NVLAP (USA) Accreditation Body & ACA/AUSTEL (Australia)
- Recognized/Listed by FCC (USA), Industry Canada (Canada)
- All test results contained in this engineering test report are traceable to National Institute of Standards and Technology (NIST)

Audio Frequency Response Of A Low Pass Filter / All Modulation States (25 kHz Channel Spacing)					
FREQUENCY (kHz)	AUDIO IN (dBV)	AUDIO OUT (dBV)	ATTEN. (OUT - IN) (dB)	ATTEN. wrt. 1 kHz (dB)	FCC LIMIT @ 90.242(b)(8) (dB)
1.00	-15.4	-13.6	1.8	0.0	0.0
2.00	-15.5	-9.8	5.7	3.9	0.0
3.00	-15.5	-7.5	8.0	6.2	0.0
3.50	-15.5	-23.6	-8.1	-9.9	-4.0
4.00	-15.5	<-53.5	<-38.0	<-39.8	-7.5
4.50	-15.5	<-63.6	<-48.1	<-49.9	-10.6
5.00	-15.5	<-67.9	<-52.4	<-54.2	-13.3
6.00	-15.5	<-95.0	<-79.5	<-81.3	-18.1
7.00	-15.5	<-95.0	<-79.5	<-81.3	-22.1
8.00	-15.5	<-95.0	<-79.5	<-81.3	-25.6
9.00	-15.5	<-95.0	<-79.5	<-81.3	-28.6
10.00	-15.5	<-95.0	<-79.5	<-81.3	-31.4
15.00	-15.5	<-95.0	<-79.5	<-81.3	-41.9
20.00	-15.5	<-95.0	<-79.5	<-81.3	-50.0
22.00	-15.5	<-95.0	<-79.5	<-81.3	-50.0
24.00	-15.5	<-95.0	<-79.5	<-81.3	-50.0
26.00	-15.5	<-95.0	<-79.5	<-81.3	-50.0
28.00	-15.5	<-95.0	<-79.5	<-81.3	-50.0
30.00	-15.5	<-95.0	<-79.5	<-81.3	-50.0
40.00	-15.5	<-95.0	<-79.5	<-81.3	-50.0
50.00	-15.5	<-95.0	<-79.5	<-81.3	-50.0

ULTRATECH GROUP OF LABS

3000 Bristol Circle, Oakville, Ontario, Canada L6H 6G4
 Tel. #: 905-829-1570, Fax. #: 905-829-8050, Email: vhk.ultratech@sympatico.ca, Website: <http://www.ultratech-labs.com>

File #: FSG27-FTX
 March 23, 2001

- Assessed by ITI (UK) Competent Body, NVLAP (USA) Accreditation Body & ACA/AUSTEL (Australia)
- Recognized/Listed by FCC (USA), Industry Canada (Canada)
- All test results contained in this engineering test report are traceable to National Institute of Standards and Technology (NIST)

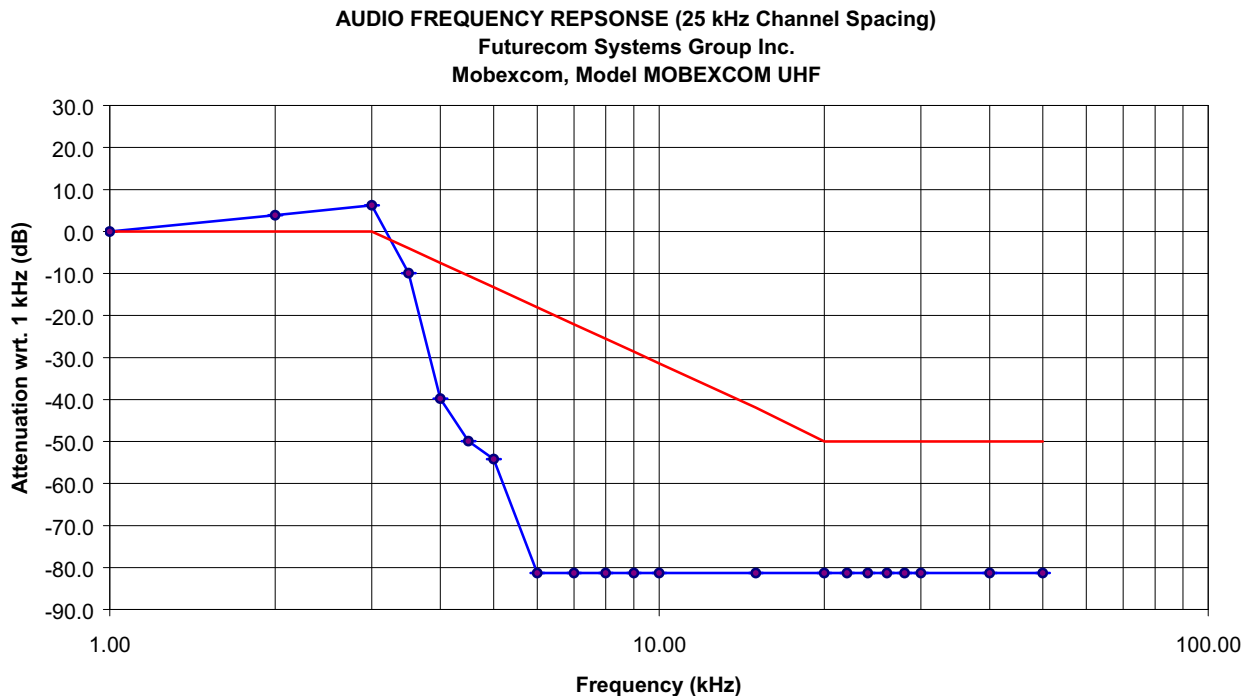

ULTRATECH GROUP OF LABS

3000 Bristol Circle, Oakville, Ontario, Canada L6H 6G4
Tel. #: 905-829-1570, Fax. #: 905-829-8050, Email: vhk.ultratech@sympatico.ca, Website: <http://www.ultratech-labs.com>

File #: FSG27-FTX
March 23, 2001

- Assessed by ITI (UK) Competent Body, NVLAP (USA) Accreditation Body & ACA/AUSTEL (Australia)
- Recognized/Listed by FCC (USA), Industry Canada (Canada)
- All test results contained in this engineering test report are traceable to National Institute of Standards and Technology (NIST)

6.8. MODULATION LIMITING @ FCC 2.1047(b) & 90.210

6.8.1. Limits @ FCC 2.1047(b) and 90.210

The EUT shall be installed with a modulation limiter, which limits the deviation of the FM carrier less than manufacturer's setting provided that the rf output spectrum must meet the required MASK

Recommendation:

- 1.25 kHz for 6.25 kHz Channel Spacing System
- 2.5 kHz for 12.5 kHz Channel Spacing System
- 5 kHz for 25 kHz Channel Spacing System

6.8.2. Method of Measurements

For Audio Transmitter:- The carrier frequency deviation was measured with the tone input signal level varied from 0 Vp to audio input rating level plus 16 dB at frequencies 0.1, 0.5, 1.0, 3.0 and 5.0 kHz. The maximum deviation was recorded at each test condition.

For Data Transmitter with Maximum Frequency Deviation set by Factory:- The EUT was set at maximum frequency deviation, and its peak frequency deviation was then measured using EUT's internal random data source.

6.8.3. Test Equipment List

Test Instruments	Manufacturer	Model No.	Serial No.	Frequency Range
Synthesized Function Generator	Stanford Research Systems	DS345	34591	1μHz – 30.2 MHz
Communication Analyzer (Test Receiver)	Marconi Instruments	2955	132037/226	400kHz - 1000 MHz

6.8.4. Test Arrangement

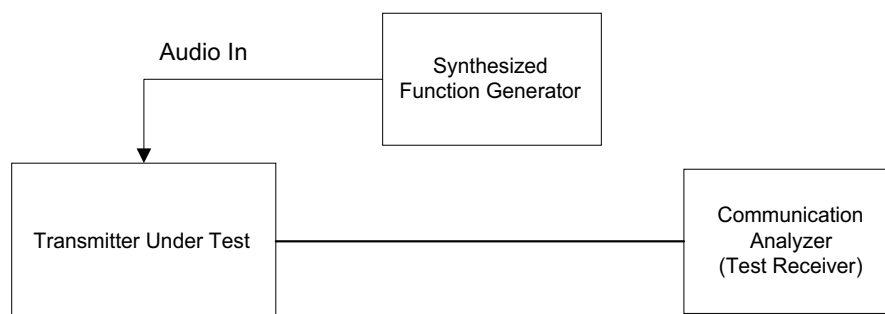

ULTRATECH GROUP OF LABS

3000 Bristol Circle, Oakville, Ontario, Canada L6H 6G4
 Tel. #: 905-829-1570, Fax. #: 905-829-8050, Email: vhk.ultratech@sympatico.ca, Website: <http://www.ultratech-labs.com>

File #: FSG27-FTX
 March 23, 2001

- Assessed by ITI (UK) Competent Body, NVLAP (USA) Accreditation Body & ACA/AUSTEL (Australia)
- Recognized/Listed by FCC (USA), Industry Canada (Canada)
- All test results contained in this engineering test report are traceable to National Institute of Standards and Technology (NIST)

6.8.5. Test Data

Voice Modulation Limiting

- 12.5 kHz Channel Spacing

12.5 kHz Channel Spacing						
Modulating Signal Level (mVrms)	Peak Frequency Deviation (kHz) at the following modulating frequency:					Recommended Maximum Limit (kHz)
	0.1 kHz	0.5 kHz	1.0 kHz	3.0 kHz	5.0 kHz	
0.1	0.1	0.2	0.2	0.5	0	2.5
0.2	0.1	0.2	0.4	1.0	0	2.5
0.4	0.1	0.4	0.7	2.0	0	2.5
0.6	0.1	0.6	1.1	2.3	0	2.5
0.8	0.1	0.7	1.4	2.3	0	2.5
1.0	0.1	0.9	1.8	2.3	0	2.5
1.5	0.1	1.3	2.3	2.3	0	2.5
2.0	0.1	1.9	2.3	2.3	0	2.5
2.5	0.1	2.2	2.2	2.3	0	2.5
3.0	0.1	2.3	2.2	2.3	0	2.5
3.5	0.2	2.3	2.2	2.3	0	2.5
4.0	0.2	2.3	2.2	2.3	0	2.5
4.5	0.3	2.3	2.2	2.3	0	2.5
5.0	0.4	2.2	2.2	2.3	0	2.5
5.5	0.5	2.2	2.2	2.3	0	2.5
6.0	0.5	2.2	2.2	2.3	0	2.5

ULTRATECH GROUP OF LABS

3000 Bristol Circle, Oakville, Ontario, Canada L6H 6G4
 Tel. #: 905-829-1570, Fax. #: 905-829-8050, Email: vhk.ultratech@sympatico.ca, Website: <http://www.ultratech-labs.com>

File #: FSG27-FTX
 March 23, 2001

- Assessed by ITI (UK) Competent Body, NVLAP (USA) Accreditation Body & ACA/AUSTEL (Australia)
- Recognized/Listed by FCC (USA), Industry Canada (Canada)
- All test results contained in this engineering test report are traceable to National Institute of Standards and Technology (NIST)

Voice Signal Input Level = STD MOD Level + 16 dB = -1.9 dB(Vrms) + 16 = **14.1 dB(Vrms)**

12.5 kHz Channel Spacing		
Modulating Frequency (kHz)	Peak Frequency Deviation (kHz)	Maximum Limit (kHz)
0.1	0.1	2.5
0.2	0.3	2.5
0.4	2.1	2.5
0.6	2.3	2.5
0.8	2.2	2.5
1.0	2.3	2.5
1.2	2.3	2.5
1.4	2.3	2.5
1.6	2.3	2.5
1.8	2.4	2.5
2.0	2.4	2.5
2.5	2.4	2.5
3.0	2.3	2.5
3.5	2.2	2.5
4.0	1.5	2.5
4.5	0.0	2.5
5.0	0.0	2.5
6.0	0.0	2.5
7.0	0.0	2.5
8.0	0.0	2.5
9.0	0.0	2.5
10.0	0.0	2.5

ULTRATECH GROUP OF LABS

3000 Bristol Circle, Oakville, Ontario, Canada L6H 6G4
 Tel. #: 905-829-1570, Fax. #: 905-829-8050, Email: vhk.ultratech@sympatico.ca, Website: <http://www.ultratech-labs.com>

File #: FSG27-FTX
 March 23, 2001

- Assessed by ITI (UK) Competent Body, NVLAP (USA) Accreditation Body & ACA/AUSTEL (Australia)
- Recognized/Listed by FCC (USA), Industry Canada (Canada)
- All test results contained in this engineering test report are traceable to National Institute of Standards and Technology (NIST)

• 25 kHz Channel Spacing

25 kHz Channel Spacing						
Modulating Signal Level (mVrms)	Peak Frequency Deviation (kHz) at the following modulating frequency:					Recommended Maximum Limit (kHz)
	0.1 kHz	0.5 kHz	1.0 kHz	3.0 kHz	5.0 kHz	
0.1	0.1	0.2	0.5	1.0	0	5
0.2	0.1	0.4	0.7	2.0	0	5
0.4	0.1	0.7	1.4	3.9	0	5
0.6	0.1	1.1	2.1	4.5	0	5
0.8	0.1	1.4	2.8	4.5	0	5
1.0	0.1	1.7	3.5	4.5	0	5
1.5	0.1	2.6	4.6	4.5	0	5
2.0	0.1	3.7	4.6	4.6	0	5
2.5	0.2	4.3	4.5	4.5	0	5
3.0	0.3	4.6	4.3	4.6	0	5
3.5	0.3	4.6	4.3	4.6	0	5
4.0	0.4	4.6	4.4	4.6	0	5
4.5	0.5	4.6	4.4	4.6	0	5
5.0	0.7	4.5	4.4	4.6	0	5
5.5	0.9	4.3	4.4	4.6	0	5
6.0	0.9	4.3	4.4	4.6	0	5

ULTRATECH GROUP OF LABS

3000 Bristol Circle, Oakville, Ontario, Canada L6H 6G4
 Tel. #: 905-829-1570, Fax. #: 905-829-8050, Email: vhk.ultratech@sympatico.ca, Website: <http://www.ultratech-labs.com>

File #: FSG27-FTX
 March 23, 2001

- Assessed by ITI (UK) Competent Body, NVLAP (USA) Accreditation Body & ACA/AUSTEL (Australia)
- Recognized/Listed by FCC (USA), Industry Canada (Canada)
- All test results contained in this engineering test report are traceable to National Institute of Standards and Technology (NIST)

Voice Signal Input Level = STD MOD Level + 16 dB = -1.9 dB(mVrms) + 16 = **14.1 dB(mVrms)**

25 kHz Channel Spacing		
Modulating Frequency (kHz)	Peak Frequency Deviation (kHz)	Maximum Limit (kHz)
0.1	0.5	5
0.2	1.7	5
0.4	4.5	5
0.6	4.3	5
0.8	4.3	5
1.0	4.4	5
1.2	4.5	5
1.4	4.3	5
1.6	4.5	5
1.8	4.9	5
2.0	4.8	5
2.5	4.5	5
3.0	4.6	5
3.5	4.4	5
4.0	3.6	5
4.5	0.7	5
5.0	0.1	5
6.0	0.1	5
7.0	0.1	5
8.0	0.1	5
9.0	0.1	5
10.0	0.1	5

ULTRATECH GROUP OF LABS

3000 Bristol Circle, Oakville, Ontario, Canada L6H 6G4
 Tel. #: 905-829-1570, Fax. #: 905-829-8050, Email: vhk.ultratech@sympatico.ca, Website: <http://www.ultratech-labs.com>

File #: FSG27-FTX
 March 23, 2001

- Assessed by ITI (UK) Competent Body, NVLAP (USA) Accreditation Body & ACA/AUSTEL (Australia)
- Recognized/Listed by FCC (USA), Industry Canada (Canada)
- All test results contained in this engineering test report are traceable to National Institute of Standards and Technology (NIST)

6.9. EMISSION MASK @ FCC 2.1049, 90.208 & 90.210

6.9.1. Limits @ FCC 90.209 & 90.210

Emissions shall be attenuated below the mean output power of the transmitter as follows:

Frequency Range (MHz)	Maximum Authorized BW (KHz)	Channel Spacing (KHz)	Recommended Frequency Deviation (KHz)	FCC Applicable Mask
403-512	20.0	25.0	5.0	90.210(b): Emission Mask B
403-512	11.25	12.5	2.5	90.210(d): Emission Mask D

6.9.2. Method of Measurements

Refer to Exhibit 8 section 8.2 of this report for measurement method.

6.9.3. Test Equipment List

Test Instruments	Manufacturer	Model No.	Serial No.	Frequency Range
Spectrum Analyzer/ EMI Receiver	Advantest	R3271	15050203	100 Hz – 26.5 GHz
Attenuator(s)	Bird	DC – 22 GHz
Audio Oscillator	Hewlett Packard	HP 204C	0989A08798	DC to 1.2 MHz

6.9.4. Test Arrangement

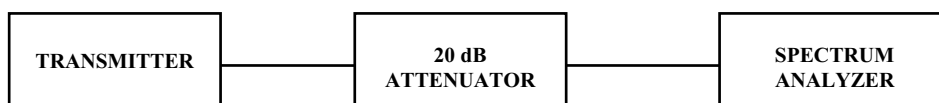

6.9.5. Test Data

Conform. Please refer to plots 7 through 24 in Exhibit 9 for details.

ULTRATECH GROUP OF LABS

3000 Bristol Circle, Oakville, Ontario, Canada L6H 6G4
 Tel. #: 905-829-1570, Fax. #: 905-829-8050, Email: vhk.ultratech@sympatico.ca, Website: <http://www.ultratech-labs.com>

File #: FSG27-FTX
 March 23, 2001

- Assessed by ITI (UK) Competent Body, NVLAP (USA) Accreditation Body & ACA/AUSTEL (Australia)
- Recognized/Listed by FCC (USA), Industry Canada (Canada)
- All test results contained in this engineering test report are traceable to National Institute of Standards and Technology (NIST)

6.10. TRANSMITTER ANTENNA POWER SPURIOUS/HARMONIC CONDUCTED EMISSIONS @ FCC 90.210

6.10.1. Limits @ 90.210

Emissions shall be attenuated below the mean output power of the transmitter as follows:

FCC Rules	Frequency Range	Attenuation Limit (dBc)
90.210(b)	10 MHz to Lowest frequency of the radio to 10 th harmonic of the highest frequency of the radio	43+10*log(P) or -13 dBm
90.210(d)	10 MHz to Lowest frequency of the radio to 10 th harmonic of the highest frequency of the radio	50+10*log(P), -20 dBm or 70 dBc whichever is less

6.10.2. Method of Measurements

Refer to Exhibit 8 section 8.3 of this report for measurement method.

6.10.3. Test Equipment List

Test Instruments	Manufacturer	Model No.	Serial No.	Frequency Range
Spectrum Analyzer/ EMI Receiver	Advantest	R3271	15050203	100 Hz – 26.5 GHz
Attenuator(s)	Bird	DC – 22 GHz
Audio Oscillator	Hewlett Packard	HP 204C	0989A08798	DC to 1.2 MHz
Highpass Filter, Microphase	MiniCircuit	SHP-600	--	Cut-off Frequency at 560 MHz

6.10.4. Test Arrangement

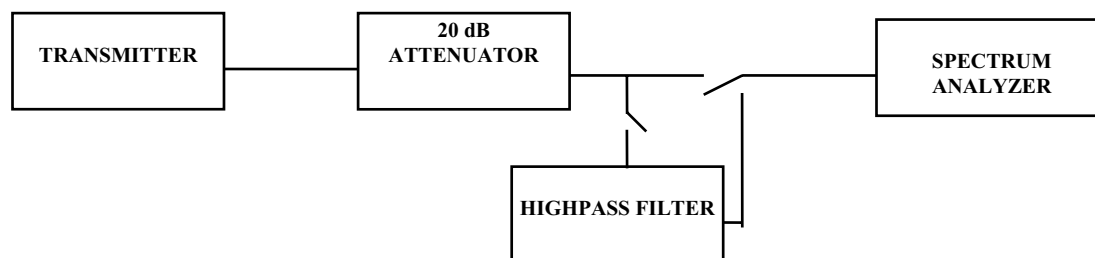

ULTRATECH GROUP OF LABS

3000 Bristol Circle, Oakville, Ontario, Canada L6H 6G4
 Tel. #: 905-829-1570, Fax. #: 905-829-8050, Email: vhk.ultratech@sympatico.ca, Website: <http://www.ultratech-labs.com>

File #: FSG27-FTX
 March 23, 2001

- Assessed by ITI (UK) Competent Body, NVLAP (USA) Accreditation Body & ACA/AUSTEL (Australia)
- Recognized/Listed by FCC (USA), Industry Canada (Canada)
- All test results contained in this engineering test report are traceable to National Institute of Standards and Technology (NIST)

6.10.5. Test Data

Remarks: The rf spurious/harmonic emission characteristics between 2 different channel spacing operations are identical. Therefore, tests were only performed with 12.5 kHz Channel Spacing operation, and the results were compared with the lowest limit of -20 dBm for the worst case.

• **Near Lowest Frequency (406.125 MHz)**

Fundamental Frequency: 406.125 MHz					
RF Output Power: 15 Watts					
Modulation: FM modulation with 2.5 kHz Sine Wave Signal					
Frequency (MHz)	RF Level (dBm)	Detector Used (Peak/QP)	Limit (dBm)	Margin (dB)	Pass / Fail
210	-25.88	Peak	-20.0	-5.9	Pass
809	-24.75	Peak	-20.0	-4.8	Pass
1220	-32.06	Peak	-20.0	-12.1	Pass
1625	-36.59	Peak	-20.0	-16.6	Pass
2030	-44.31	Peak	-20.0	-24.3	Pass
3650	-33.91	Peak	-20.0	-13.9	Pass
4055	-34.41	Peak	-20.0	-14.4	Pass
4871	-42.84	Peak	-20.0	-22.8	Pass
The emissions were scanned from 10 MHz to 5 GHz and all emissions within 30 dB below the limits were recorded.					

• **Near Middle Frequency (450 MHz)**

Fundamental Frequency: 450 MHz					
RF Output Power: 15 Watts					
Modulation: FM modulation with 2.5 kHz Sine Wave Signal					
Frequency (MHz)	RF Level (dBm)	Detector Used (Peak/QP)	Limit (dBm)	Margin (dB)	Pass / Fail
558	-46.50	Peak	-20.0	-26.5	Pass
899	-43.25	Peak	-20.0	-23.3	Pass
1349	-37.88	Peak	-20.0	-17.9	Pass
1799	-38.47	Peak	-20.0	-18.5	Pass
2249	-26.75	Peak	-20.0	-6.8	Pass
3149	-43.41	Peak	-20.0	-23.4	Pass
4049	-37.09	Peak	-20.0	-17.1	Pass
4499	-43.34	Peak	-20.0	-23.3	Pass
The emissions were scanned from 10 MHz to 5 GHz and all emissions within 30 dB below the limits were recorded.					

ULTRATECH GROUP OF LABS

3000 Bristol Circle, Oakville, Ontario, Canada L6H 6G4
 Tel. #: 905-829-1570, Fax. #: 905-829-8050, Email: vhk.ultratech@sympatico.ca, Website: <http://www.ultratech-labs.com>

File #: FSG27-FTX
 March 23, 2001

- Assessed by ITI (UK) Competent Body, NVLAP (USA) Accreditation Body & ACA/AUSTEL (Australia)
- Recognized/Listed by FCC (USA), Industry Canada (Canada)
- All test results contained in this engineering test report are traceable to National Institute of Standards and Technology (NIST)

• **Near Highest Frequency (470 MHz)**

Fundamental Frequency: 470 MHz					
RF Output Power: 15 Watts					
Modulation: FM modulation with 2.5 kHz Sine Wave Signal					
Frequency (MHz)	RF Level (dBm)	Detector Used (Peak/QP)	Limit (dBm)	Margin (dB)	Pass / Fail
937	-39.19	Peak	-20.0	-19.2	Pass
1406	-26.47	Peak	-20.0	-6.5	Pass
1876	-40.53	Peak	-20.0	-20.5	Pass
2345	-36.09	Peak	-20.0	-16.1	Pass
2821	-46.38	Peak	-20.0	-26.4	Pass
3290	-38.84	Peak	-20.0	-18.8	Pass
3759	-45.50	Peak	-20.0	-25.5	Pass
4229	-45.94	Peak	-20.0	-25.9	Pass
The emissions were scanned from 10 MHz to 5 GHz and all emissions within 30 dB below the limits were recorded.					

• **Transmitter Antenna Power Conducted Emissions Test Data Plots**

Please refer to plots 25 through 30 in Exhibit 9 Test Data Plots for details.

ULTRATECH GROUP OF LABS

3000 Bristol Circle, Oakville, Ontario, Canada L6H 6G4
 Tel. #: 905-829-1570, Fax. #: 905-829-8050, Email: vhk.ultratech@sympatico.ca, Website: <http://www.ultratech-labs.com>

File #: FSG27-FTX
 March 23, 2001

- Assessed by ITI (UK) Competent Body, NVLAP (USA) Accreditation Body & ACA/AUSTEL (Australia)
- Recognized/Listed by FCC (USA), Industry Canada (Canada)
- All test results contained in this engineering test report are traceable to National Institute of Standards and Technology (NIST)

6.11. TRANSMITTER SPURIOUS/HARMONIC RADIATED EMISSIONS @ FCC 90.210

6.11.1. Limits @ FCC 90.210

Emissions shall be attenuated below the mean output power of the transmitter as follows:

Frequency Range (MHz)	Maximum Authorized BW (KHz)	Channel Spacing (KHz)	Recommended Frequency Deviation (KHz)	FCC Applicable Mask
403-512	20.0	25.0	5.0	§90.210(b): Mask B
403-512	11.25	12.5	2.5	§90.210(d): Mask D

6.11.2. Method of Measurements

Refer to Exhibit 8 section 8.4 of this report for measurement details

6.11.3. Test Equipment List

Test Instruments	Manufacturer	Model No.	Serial No.	Frequency Range
Spectrum Analyzer/EMI Receiver	Advantest	R3271	15050203	100 Hz to 32 GHz with external mixer for frequency above 32 GHz
Microwave Amplifier	Hewlett Packard	HP 83017A	3116A0066 1	1 GHz to 26.5 GHz
Active Loop Antenna	EMCO	6507	8906-1167	1 kHz – 30 MHz
Biconilog Antenna	EMCO	3143	1029	20 MHz to 2 GHz
Horn Antenna	EMCO	3155	9701-5061	1 GHz – 18 GHz
Horn Antenna with Mixer	EMCO	3160-09	1007	18 GHz – 26.5 GHz
Horn Antenna with Mixer	EMCO	3160-10	1001	26.5 GHz – 40 GHz

ULTRATECH GROUP OF LABS

3000 Bristol Circle, Oakville, Ontario, Canada L6H 6G4
 Tel. #: 905-829-1570, Fax. #: 905-829-8050, Email: vhk.ultratech@sympatico.ca, Website: <http://www.ultratech-labs.com>

File #: FSG27-FTX
 March 23, 2001

- Assessed by ITI (UK) Competent Body, NVLAP (USA) Accreditation Body & ACA/AUSTEL (Australia)
- Recognized/Listed by FCC (USA), Industry Canada (Canada)
- All test results contained in this engineering test report are traceable to National Institute of Standards and Technology (NIST)

6.11.4. Test Arrangement

The following drawings show details of the test setup for radiated emissions measurements

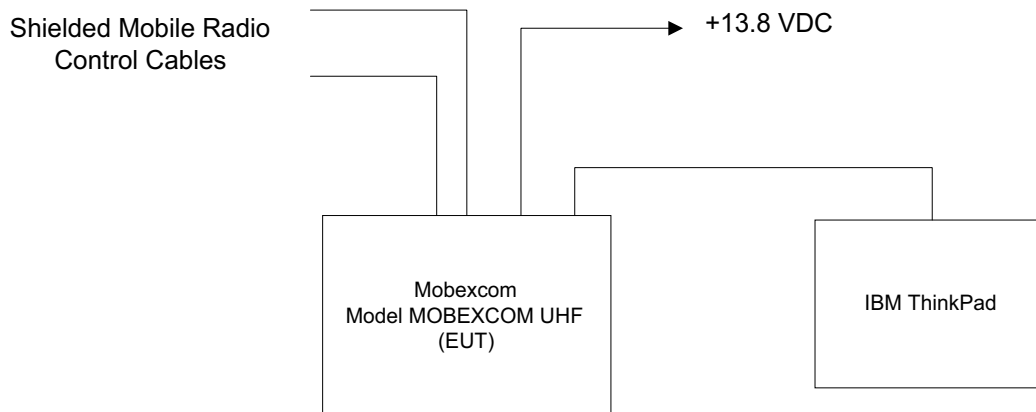

RF Output, Tx, Rx and Switching Plate Connectors were all terminated with 50 Ohms Load

ULTRATECH GROUP OF LABS

3000 Bristol Circle, Oakville, Ontario, Canada L6H 6G4
Tel. #: 905-829-1570, Fax. #: 905-829-8050, Email: vhk.ultratech@sympatico.ca, Website: <http://www.ultratech-labs.com>

File #: FSG27-FTX
March 23, 2001

- Assessed by ITI (UK) Competent Body, NVLAP (USA) Accreditation Body & ACA/AUSTEL (Australia)
- Recognized/Listed by FCC (USA), Industry Canada (Canada)
- All test results contained in this engineering test report are traceable to National Institute of Standards and Technology (NIST)

6.11.5. Test Data

Remarks:

- The rf spurious/harmonic emission characteristics between 2 different channel spacing operations are identical. Therefore, the following radiated emissions were performed on the radio set with 12.5 kHz Channel Spacing operation, and the results were compared with the lowest limit of -20 dBm for the worst case.
- The Radiated emissions were performed at 3 meters distance.
- **Near Lowest Frequency (406.125 MHz)**

Fundamental Frequency: 406.125 MHz							
RF Output Power: 15 Watts							
Modulation: FM modulation with 2.5 kHz sine wave signal							
Frequency (MHz)	RF Field Level @ 3 m (dBμV/m)	RF Power Level (dBm)	Detector Used (Peak/QP)	Antenna Plane (H/V)	Limit @ 3 m (dBm)	Margin (dB)	Pass/Fail
1218.375	64.63	-32.9	PEAK	V	-20.0	-12.9	PASS
1218.375	65.47	-32.0	PEAK	H	-20.0	-12.0	PASS
1624.500	55.13	-42.4	PEAK	V	-20.0	-22.4	PASS
1624.500	52.06	-45.4	PEAK	H	-20.0	-25.4	PASS
2030.625	46.34	-51.2	PEAK	V	-20.0	-31.2	PASS
2030.625	49.72	-47.8	PEAK	H	-20.0	-27.8	PASS
The emissions were scanned from 10 MHz to 5 GHz and all emissions within 40 dB below the limits were recorded.							

ULTRATECH GROUP OF LABS

3000 Bristol Circle, Oakville, Ontario, Canada L6H 6G4
 Tel. #: 905-829-1570, Fax. #: 905-829-8050, Email: vhk.ultratech@sympatico.ca, Website: <http://www.ultratech-labs.com>

File #: FSG27-FTX
 March 23, 2001

- Assessed by ITI (UK) Competent Body, NVLAP (USA) Accreditation Body & ACA/AUSTEL (Australia)
- Recognized/Listed by FCC (USA), Industry Canada (Canada)
- All test results contained in this engineering test report are traceable to National Institute of Standards and Technology (NIST)

Futurecom Systems Group Inc.
Mobexcom, Model No.: Mobexcom UHF
Fundamental Frequency: 406.125 MHz
Transmitter Radiated Emissions Measurements at 3 meters OFTS

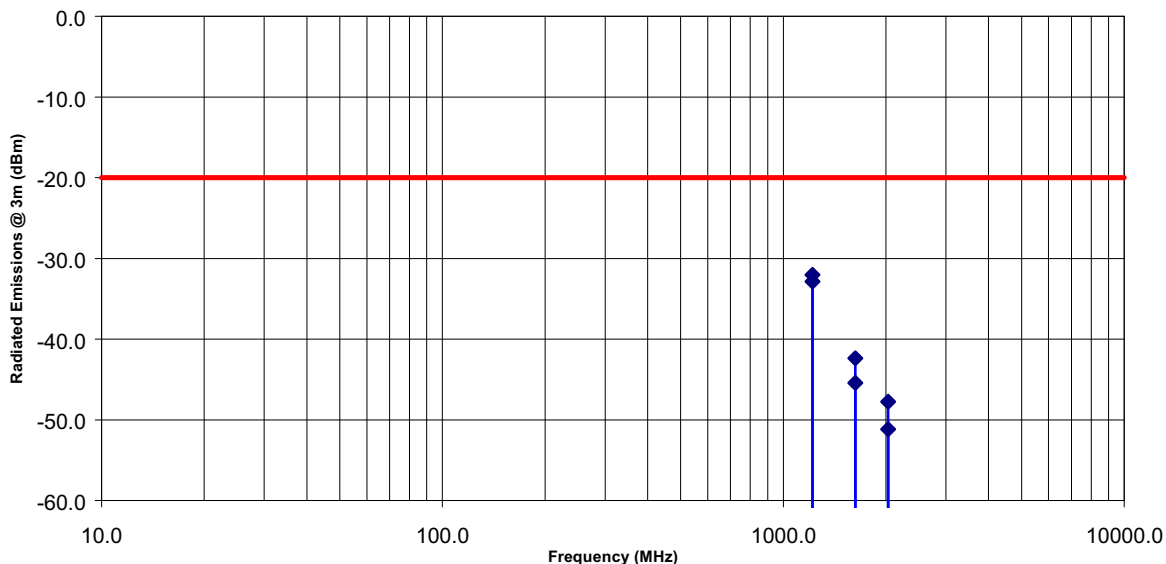

ULTRATECH GROUP OF LABS

3000 Bristol Circle, Oakville, Ontario, Canada L6H 6G4
Tel. #: 905-829-1570, Fax. #: 905-829-8050, Email: vhk.ultratech@sympatico.ca, Website: <http://www.ultratech-labs.com>

File #: FSG27-FTX
March 23, 2001

- Assessed by ITI (UK) Competent Body, NVLAP (USA) Accreditation Body & ACA/AUSTEL (Australia)
- Recognized/Listed by FCC (USA), Industry Canada (Canada)
- All test results contained in this engineering test report are traceable to National Institute of Standards and Technology (NIST)

• **Near Middle Frequency (450 MHz)**

Fundamental Frequency:		450 MHz					
RF Output Power:		15 Watts					
Modulation:		FM modulation with 2.5 kHz sine wave signal					
Frequency (MHz)	RF Field Level @ 3 m (dBμV/m)	RF Power Level (dBm)	Detector Used (Peak/QP)	Antenna Plane (H/V)	Limit @ 3 m (dBm)	Margin (dB)	Pass/Fail
900.00	40.53	-57.0	PEAK	V	-20.0	-37.0	PASS
900.00	46.06	-51.4	PEAK	H	-20.0	-31.4	PASS
1350.00	56.81	-40.7	PEAK	V	-20.0	-20.7	PASS
1350.00	51.63	-45.9	PEAK	H	-20.0	-25.9	PASS
1800.00	44.88	-52.6	PEAK	V	-20.0	-32.6	PASS
1800.00	42.34	-55.2	PEAK	H	-20.0	-35.2	PASS
2250.00	41.28	-56.2	PEAK	V	-20.0	-36.2	PASS
2250.00	41.78	-55.7	PEAK	H	-20.0	-35.7	PASS

The emissions were scanned from 10 MHz to 5 GHz and all emissions within 40 dB below the limits were recorded.

Futurecom Systems Group Inc.
Mobexcom, Model No.: MOBEXCOM UHF
Fundamental Frequency: 450 MHz
Transmitter Radiated Emissions Measurements at 3 meters OFTS

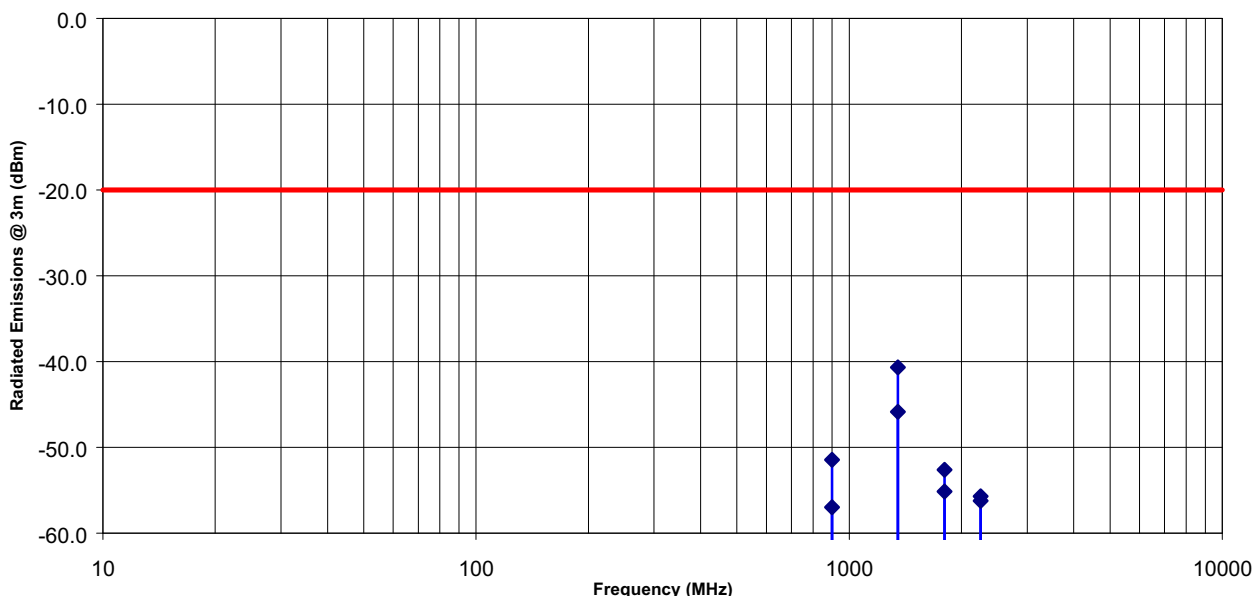

ULTRATECH GROUP OF LABS

3000 Bristol Circle, Oakville, Ontario, Canada L6H 6G4
 Tel. #: 905-829-1570, Fax. #: 905-829-8050, Email: vhk.ultratech@sympatico.ca, Website: <http://www.ultratech-labs.com>

File #: FSG27-FTX
 March 23, 2001

- Assessed by ITI (UK) Competent Body, NVLAP (USA) Accreditation Body & ACA/AUSTEL (Australia)
- Recognized/Listed by FCC (USA), Industry Canada (Canada)
- All test results contained in this engineering test report are traceable to National Institute of Standards and Technology (NIST)

• **Near Highest Frequency (470 MHz)**

Fundamental Frequency:		470 MHz					
RF Output Power:		15 Watts					
Modulation:		FM modulation with 2.5 kHz sine wave signal					
Frequency (MHz)	RF Field Level @ 3 m (dBµV/m)	RF Power Level (dBm)	Detector Used (Peak/QP)	Antenna Plane (H/V)	Limit @ 3 m (dBm)	Margin (dB)	Pass/Fail
940.00	43.00	-54.5	PEAK	V	-20.0	-34.5	PASS
940.00	44.56	-52.9	PEAK	H	-20.0	-32.9	PASS
1410.00	60.03	-37.5	PEAK	V	-20.0	-17.5	PASS
1410.00	60.50	-37.0	PEAK	H	-20.0	-17.0	PASS
1880.00	44.41	-53.1	PEAK	V	-20.0	-33.1	PASS
1880.00	45.44	-52.1	PEAK	H	-20.0	-32.1	PASS
2350.00	44.50	-53.0	PEAK	V	-20.0	-33.0	PASS
2350.00	44.75	-52.8	PEAK	H	-20.0	-32.8	PASS

The emissions were scanned from 10 MHz to 5 GHz and all emissions within 40 dB below the limits were recorded.

Futurecom Systems Group Inc.
Mobexcom, Model No.: MOBEXCOM UHF
Fundamental Frequency: 470 MHz
Transmitter Radiated Emissions Measurements at 3 meters OFTS

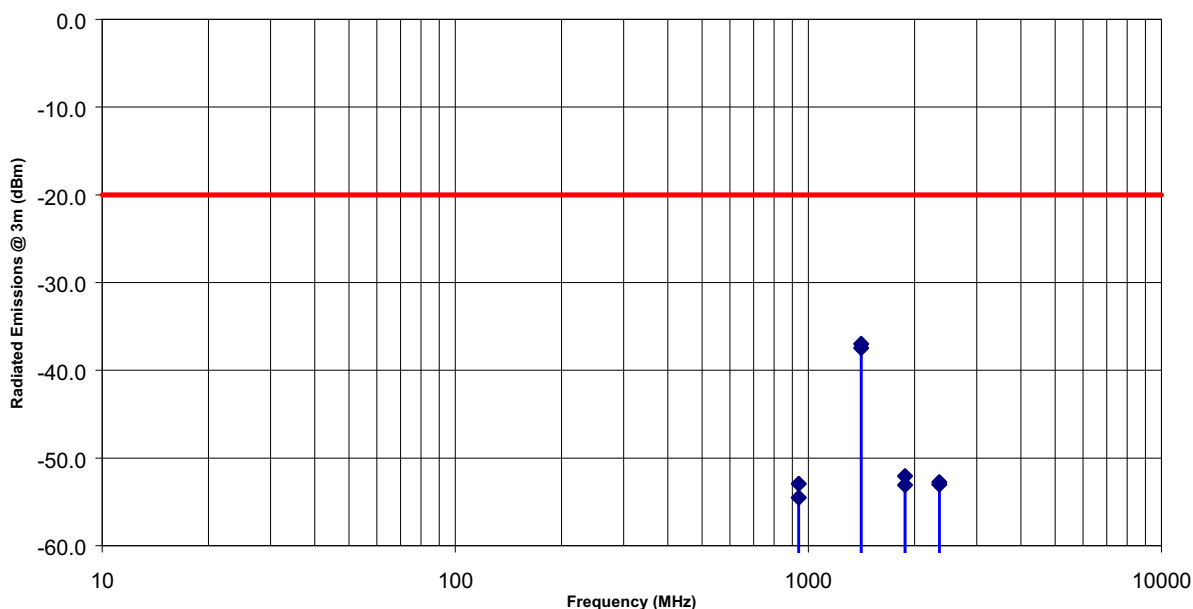

ULTRATECH GROUP OF LABS

3000 Bristol Circle, Oakville, Ontario, Canada L6H 6G4
 Tel. #: 905-829-1570, Fax. #: 905-829-8050, Email: vhk.ultratech@sympatico.ca, Website: <http://www.ultratech-labs.com>

File #: FSG27-FTX
 March 23, 2001

- Assessed by ITI (UK) Competent Body, NVLAP (USA) Accreditation Body & ACA/AUSTEL (Australia)
- Recognized/Listed by FCC (USA), Industry Canada (Canada)
- All test results contained in this engineering test report are traceable to National Institute of Standards and Technology (NIST)

6.12. TRANSIENT FREQUENCY BEHAVIOR @ 90.214

6.12.1. Limits

Transient frequencies must be within the maximum frequency difference limits during the time intervals indicated:

Time intervals ^{1, 2}	Maximum frequency difference ³	All equipment
		421 to 512 MHz
Transient Frequency Behavior for Equipment Designed to Operate on 25 kHz Channels		
t_1 ⁴	± 25.0 kHz	10.0 ms
t_2	± 12.5 kHz	25.0 ms
t_3 ⁴	± 25.0 kHz	10.0 ms
Transient Frequency Behavior for Equipment Designed to Operate on 12.5 kHz Channels		
t_1 ⁴	± 12.5 kHz	10.0 ms
t_2	± 6.25 kHz	25.0 ms
t_3 ⁴	± 12.5 kHz	10.0 ms

- t_{on} is the instant when a 1 kHz test signal is completely suppressed, including any capture time due to phasing.
 t_1 is the time period immediately following t_{on} .
 t_2 is the time period immediately following t_1 .
 t_3 is the time period from the instant when the transmitter is turned off until t_{off} .
 t_{off} is the instant when the 1 kHz test signal starts to rise.
- During the time from the end of t_2 to the beginning of t_3 , the frequency difference must not exceed the limits specified in § 90.213.
- Difference between the actual transmitter frequency and the assigned transmitter frequency.
- If the transmitter carrier output power rating is 6 watts or less, the frequency difference during this time period may exceed the maximum frequency difference for this time period.

6.12.2. Method of Measurements

Refer to Exhibit 8 section 8.5 of this test report and ANSI/TIA/EIA - 603 - 1992, Sec. 2.2.19, Page 83

ULTRATECH GROUP OF LABS

3000 Bristol Circle, Oakville, Ontario, Canada L6H 6G4
 Tel. #: 905-829-1570, Fax. #: 905-829-8050, Email: vhk.ultratech@sympatico.ca, Website: <http://www.ultratech-labs.com>

File #: FSG27-FTX
 March 23, 2001

- Assessed by ITI (UK) Competent Body, NVLAP (USA) Accreditation Body & ACA/AUSTEL (Australia)
- Recognized/Listed by FCC (USA), Industry Canada (Canada)
- All test results contained in this engineering test report are traceable to National Institute of Standards and Technology (NIST)

6.12.3. Test Equipment List

Test Instruments	Manufacturer	Model No.	Serial No.	Frequency Range
RF Synthesized Signal Generator	Gigatronic	6061A	5130408	10kHz – 1050 MHz
Communication Analyzer (Test Receiver)	Marconi Instruments	2955	132037/226	400kHz - 1000 MHz
67297 RF Detector,	Herotex	DZ122-553	63400	..
Network Combiner	Weinschel Corp	1515	LW725	DC -18 GHz
Network Combiner	Weinschel Corp	1515	LU400	DC -18 GHz
Infinium Oscilloscopes	Hewlett Packard	54810A	US38380192	1 Gsa/s

6.12.4. Test Arrangement

The following drawings show details of the test setup for transient frequency behavior measurements

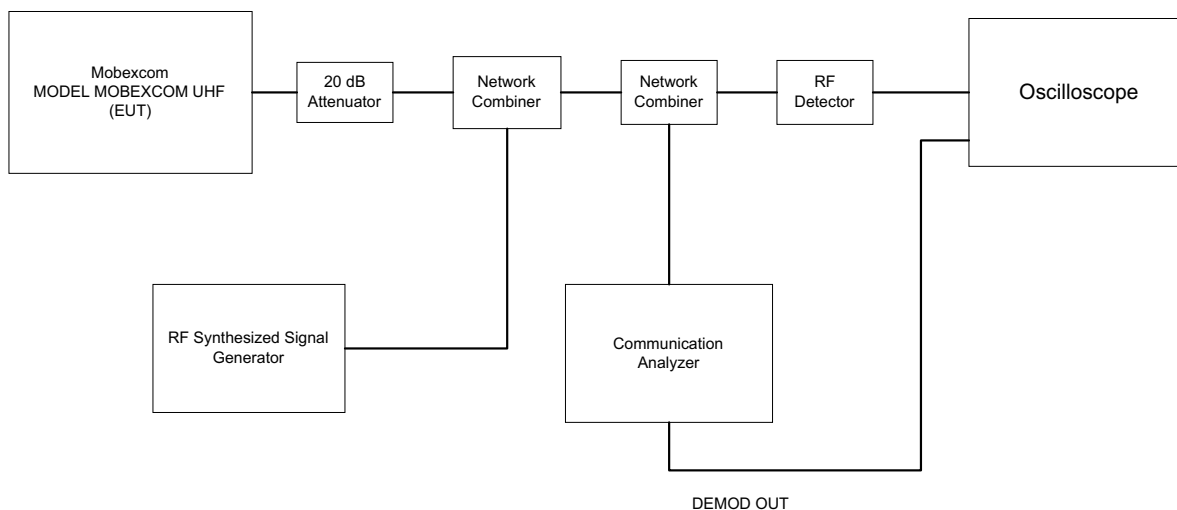

ULTRATECH GROUP OF LABS

3000 Bristol Circle, Oakville, Ontario, Canada L6H 6G4
 Tel. #: 905-829-1570, Fax. #: 905-829-8050, Email: vhk.ultratech@sympatico.ca, Website: <http://www.ultratech-labs.com>

File #: FSG27-FTX
 March 23, 2001

- Assessed by ITI (UK) Competent Body, NVLAP (USA) Accreditation Body & ACA/AUSTEL (Australia)
- Recognized/Listed by FCC (USA), Industry Canada (Canada)
- All test results contained in this engineering test report are traceable to National Institute of Standards and Technology (NIST)

6.12.5. Test Data

- 12.5 kHz Channel Spacing Operation

Test Configuration #1: FM modulation with 2.5 KHz Sine Wave		
Time Interval	Transient Frequency (kHz)	Transient Frequency Limit
t ₁ (10 ms) Switch On Condition	-9.0	12.5 kHz or no limit for RF Output Power < 6 Watts
t ₂ (25 ms) Switch On Condition	0.0	6.25 kHz
After t ₂ (10 ms) Switch On Condition	0.0	FCC Limit = ± 1015 Hz (2.5 ppm @ 406.125 MHz)
Before t ₃ (10 ms) Switch Off Condition	0.0	FCC Limit = ± 1015 Hz (2.5ppm @ 406.125 MHz)
t ₃ (10 ms) Switch Off Condition	+6.7	12.5 kHz or no limit for RF Output Power < 6 Watts
Test Configuration #2: Unmodulated		
t ₁ (10 ms) Switch On Condition	-2.3	12.5 kHz or no limit for RF Output Power < 6 Watts
t ₂ (25 ms) Switch On Condition	0.0	6.25 kHz
After t ₂ (10 ms) Switch On Condition	0.0	FCC Limit = ± 1015 Hz (2.5 ppm @ 406.125 MHz)
Before t ₃ (10 ms) Switch Off Condition	0.0	FCC Limit = ± 1015 Hz (2.5ppm @ 406.125 MHz)
t ₃ (10 ms) Switch Off Condition	+5.5	12.5 kHz or no limit for RF Output Power < 6 Watts

ULTRATECH GROUP OF LABS

3000 Bristol Circle, Oakville, Ontario, Canada L6H 6G4
 Tel. #: 905-829-1570, Fax. #: 905-829-8050, Email: vhk.ultratech@sympatico.ca, Website: <http://www.ultratech-labs.com>

File #: FSG27-FTX
 March 23, 2001

- Assessed by ITI (UK) Competent Body, NVLAP (USA) Accreditation Body & ACA/AUSTEL (Australia)
- Recognized/Listed by FCC (USA), Industry Canada (Canada)
- All test results contained in this engineering test report are traceable to National Institute of Standards and Technology (NIST)

• **25 kHz Channel Spacing Operation**

Test Configuration #1: FM modulation with 2.5 KHz Sine Wave		
Time Interval	Transient Frequency	Transient Frequency Limit
t ₁ (10 ms) Switch On Condition	-5.5	25 kHz or no limit for RF Output Power < 6 Watts
t ₂ (25 ms) Switch On Condition	0.0	12.5 kHz
After t ₂ (10 ms) Switch On Condition	0.0	FCC Limit = ± 2031 Hz (5 ppm @ 406.125 MHz)
Before t ₃ (10 ms) Switch Off Condition	0.0	FCC Limit = ± 2031 Hz (5 ppm @ 406.125 MHz)
t ₃ (10 ms) Switch Off Condition	-7.8	25 kHz or no limit for RF Output Power < 6 Watts
Test Configuration #2: Unmodulated		
t ₁ (10 ms) Switch On Condition	+8.6	25 kHz or no limit for RF Output Power < 6 Watts
t ₂ (25 ms) Switch On Condition	0.0	12.5 kHz
After t ₂ (10 ms) Switch On Condition	0.0	FCC Limit = ± 2031 Hz (5 ppm @ 406.125 MHz)
Before t ₃ (10 ms) Switch Off Condition	0.0	FCC Limit = ± 2031 Hz (5 ppm @ 406.125 MHz)
t ₃ (10 ms) Switch Off Condition	+15.6	25 kHz or no limit for RF Output Power < 6 Watts

• **Transient Frequency Behavior Test Data Plots**

Please refer to plots 31 through 34 in Exhibit 9 Test Data Plots for details.

ULTRATECH GROUP OF LABS

3000 Bristol Circle, Oakville, Ontario, Canada L6H 6G4
 Tel. #: 905-829-1570, Fax. #: 905-829-8050, Email: vhk.ultratech@sympatico.ca, Website: <http://www.ultratech-labs.com>

File #: FSG27-FTX
 March 23, 2001

- Assessed by ITI (UK) Competent Body, NVLAP (USA) Accreditation Body & ACA/AUSTEL (Australia)
- Recognized/Listed by FCC (USA), Industry Canada (Canada)
- All test results contained in this engineering test report are traceable to National Institute of Standards and Technology (NIST)

EXHIBIT 7. MEASUREMENT UNCERTAINTY

The measurement uncertainties stated were calculated in accordance with the requirements of NIST Technical Note 1297 and NIS 81 (1994)

7.1. RADIATED EMISSION MEASUREMENT UNCERTAINTY

CONTRIBUTION (Radiated Emissions)	PROBABILITY DISTRIBUTION	UNCERTAINTY (\pm dB)	
		3 m	10 m
Antenna Factor Calibration	Normal (k=2)	± 1.0	± 1.0
Cable Loss Calibration	Normal (k=2)	± 0.3	± 0.5
EMI Receiver specification	Rectangular	± 1.5	± 1.5
Antenna Directivity	Rectangular	± 0.5	± 0.5
Antenna factor variation with height	Rectangular	± 2.0	± 0.5
Antenna phase center variation	Rectangular	0.0	± 0.2
Antenna factor frequency interpolation	Rectangular	± 0.25	± 0.25
Measurement distance variation	Rectangular	± 0.6	± 0.4
Site imperfections	Rectangular	± 2.0	± 2.0
Mismatch: Receiver VRC $\Gamma_1 = 0.2$ Antenna VRC $\Gamma_R = 0.67(\text{Bi}) 0.3 (\text{Lp})$ Uncertainty limits $20\text{Log}(1 \pm \Gamma_1 \Gamma_R)$	U-Shaped	+1.1 -1.25	± 0.5
System repeatability	Std. Deviation	± 0.5	± 0.5
Repeatability of EUT		-	-
Combined standard uncertainty	Normal	+2.19 / -2.21	+1.74 / -1.72
Expanded uncertainty U	Normal (k=2)	+4.38 / -4.42	+3.48 / -3.44

Calculation for maximum uncertainty when 3m biconical antenna including a factor of k=2 is used:

$$U = 2u_c(y) = 2x(+2.19) = +4.38 \text{ dB} \quad \text{And} \quad U = 2u_c(y) = 2x(-2.21) = -4.42 \text{ dB}$$

ULTRATECH GROUP OF LABS

3000 Bristol Circle, Oakville, Ontario, Canada L6H 6G4
 Tel. #: 905-829-1570, Fax. #: 905-829-8050, Email: vhk.ultratech@sympatico.ca, Website: <http://www.ultratech-labs.com>

File #: FSG27-FTX
 March 23, 2001

- Assessed by ITI (UK) Competent Body, NVLAP (USA) Accreditation Body & ACA/AUSTEL (Australia)
- Recognized/Listed by FCC (USA), Industry Canada (Canada)
- All test results contained in this engineering test report are traceable to National Institute of Standards and Technology (NIST)

EXHIBIT 8. MEASUREMENT METHODS

8.1. FREQUENCY STABILITY

Refer to FCC @ 2.1055.

- (a) The frequency stability shall be measured with variation of ambient temperature as follows: From -30 to +50 centigrade except that specified in subparagraph (2) & (3) of this paragraph.
- (b) Frequency measurements shall be made at extremes of the specified temperature range and at intervals of not more than 10 centigrade through the range. A period of time sufficient to stabilize all of the components of the oscillator circuit at each temperature level shall be allowed prior to frequency measurement. The short-term transient effects on the frequency of the transmitter due to keying (except for broadcast transmitters) and any heating element cycling normally occurring at each ambient temperature level also shall be shown. Only the portion or portions of the transmitter containing the frequency determining and stability circuitry need be subjected to the temperature variation test.
- (d) The frequency stability supply shall be measured with variation of primary supply voltage as follows:
 - (1) Vary primary supply voltage from 85 to 115 percent of the nominal value for other than hand carried battery equipment.
 - (2) For hand carried, battery powered equipment, reduce primary supply voltage to the battery operating end point which shall be specified by the manufacturer.
 - (3) The supply voltage shall be measured at the input to the cable normally provide with the equipment, or at the power supply terminals if cables are not normally provided. Effects on frequency of transmitter keying (except for broadcast transmitters) and any heating element cycling at the nominal supply voltage and at each extreme also shall be shown.
- (e) When deemed necessary, the Commission may require tests of frequency stability under conditions in addition to those specifically set out in paragraphs (a), (b), (c) and (d) of this section. (For example, measurements showing the effect of proximity to large metal objects, or of various types of antennas, may be required for portable equipment).

ULTRATECH GROUP OF LABS

3000 Bristol Circle, Oakville, Ontario, Canada L6H 6G4
Tel. #: 905-829-1570, Fax. #: 905-829-8050, Email: vhk.ultratech@sympatico.ca, Website: <http://www.ultratech-labs.com>

File #: FSG27-FTX
March 23, 2001

- Assessed by ITI (UK) Competent Body, NVLAP (USA) Accreditation Body & ACA/AUSTEL (Australia)
- Recognized/Listed by FCC (USA), Industry Canada (Canada)
- All test results contained in this engineering test report are traceable to National Institute of Standards and Technology (NIST)

8.2. EMISSION MASK

Voice or Digital Modulation Through a Voice Input Port @ 2.1049(c)(1):- The transmitter was modulated by a 2.5 KHz tone signal at an input level 16 dB greater than that required to produce 50% modulation (e.g.: ± 2.5 KHz peak deviation at 1 KHz modulating frequency). The input level was established at the frequency of maximum response of the audio modulating circuit.

Digital Modulation Through a Data Input Port @ 2.1049(h):- Transmitters employing digital modulation techniques - when modulated by an input signal such that its amplitude and symbol rate represent the maximum rated conditions under which the equipment will be operated. The signal shall be applied through any filter networks, pseudo-random generators or other devices required in normal service. Additionally, the Emission Masks shall be shown for operation with any devices used for modifying the spectrum when such devices are operational at the discretion of the user.

The following spectrum analyzer bandwidth shall be used for measurement of Emission Mask/Out-of-Band Emission Measurements:

- (1) For 25 kHz Channel Spacing: RBW = 300 Hz
- (2) For 12.5 kHz or 6.25 kHz Channel Spacings: RBW = 100 Hz

The all cases the Video Bandwidth shall be equal or greater than the measuring bandwidth.

8.3. SPURIOUS EMISSIONS (CONDUCTED)

With transmitter modulation characteristics described in Out-of-Band Emissions measurements @ 2.1049, the transmitter spurious and harmonic emissions were scanned. The spurious and harmonic emissions were measured with the Spectrum Analyzer controls set as RBW = 30 kHz minimum , VBW \geq RBW and SWEEP TIME = AUTO). The transmitter was operated at a full rated power output, and modulated as follows:

FCC CFR 47, Para. 2.1057 - Frequency spectrum to be investigated:- The spectrum was investigated from the lowest radio generated in the equipment up to at least the 10th harmonic of the carrier frequency or to the highest frequency practicable in the present state of the art of measuring techniques, whichever is lower. Particular attention should be paid to harmonics and subharmonics of the carrier frequency. Radiation at the frequencies of multiplier stages should be checked. The amplitude of spurious emissions which are attenuated more than 20 dB below the permissible value need not be reported.

FCC CFR 47, Para. 2.1051 - Spurious Emissions at Antenna Terminal:- The radio frequency voltage or powers generated within the equipment and appearing on a spurious frequency shall be checked at the equipment output terminals when properly loaded with a suitable artificial antenna. Curves or equivalent data shall show the magnitude of the harmonic and other spurious emission that can be detected when the equipment is operated under the conditions specified in 2.1049 as appropriate. The magnitude of spurious emissions which are attenuated more than 20 dB below the permissible value need not be specified.

ULTRATECH GROUP OF LABS

3000 Bristol Circle, Oakville, Ontario, Canada L6H 6G4
Tel. #: 905-829-1570, Fax. #: 905-829-8050, Email: vhk.ultratech@sympatico.ca, Website: <http://www.ultratech-labs.com>

File #: FSG27-FTX
March 23, 2001

- Assessed by ITI (UK) Competent Body, NVLAP (USA) Accreditation Body & ACA/AUSTEL (Australia)
- Recognized/Listed by FCC (USA), Industry Canada (Canada)
- All test results contained in this engineering test report are traceable to National Institute of Standards and Technology (NIST)

8.4. SPURIOUS EMISSIONS (RADIATED)

With transmitter modulation characteristics described in Out-of-Band Emissions measurements @ 2.1049, the transmitter spurious and harmonic emissions were scanned. The spurious and harmonic emissions were measured with the Spectrum Analyzer controls set as RBW = 100 kHz minimum , VBW \geq RBW and SWEEP TIME = AUTO). The transmitter was operated at a full rated power output, and modulated as follows:

FCC CFR 47, Para. 2.1057 - Frequency spectrum to be investigated:- The spectrum was investigated from the lowest radio generated in the equipment up to at least the 10th harmonic of the carrier frequency or to the highest frequency practicable in the present state of the art of measuring techniques, whichever is lower. Particular attention should be paid to harmonics and subharmonics of the carrier frequency. Radiation at the frequencies of multiplier stages should be checked. The amplitude of spurious emissions which are attenuated more than 20 dB below the permissible value need not be reported.

FCC CFR 47, Para. 2.1053 - Field Strength Spurious Emissions

- (a) Measurements was made to detect spurious emissions radiated directly from the cabinet, control circuits, power leads, or intermediate circuit elements under normal conditions of installation and operation. Curves or equivalent data were supplied showing the magnitude of each harmonic and other spurious emission. For this test, single sideband, independent sideband, and controlled carrier transmitters shall be modulated under the conditions specified in paragraph 2.1049(c) as appropriate. For equipment operating on frequencies below 1 GHz , an Open Field Test is normally required, with the measuring instrument antenna located in the far field at all test frequencies. In event it is either impractical or impossible to make open field measurements (e.g. a broadcast transmitter installed in a building) measurement will be accepted of the equipment as installed. Such measurements must be accompanied by a description of the site where the measurements were made showing the location of any possible source of reflections which might distort the field strength measurements. Information submitted shall include the relative radiated power of each spurious emission with the reference to the rated power output of the transmitter, assuming all emissions are radiated from half-wave dipole antennas.
- (b) Measurements specified in paragraph (a) of this section shall be made for the following equipment:
- (1) Those in which the spurious emission are required to be 60 dB or more below the mean power of the transmitter.
 - (2) All equipment operating on frequencies higher than 25 MHz
 - (3) All equipment where the antenna is an integral part of, and attached directly to the transmitter.
 - (4) Other types of equipment as required, when deemed necessary by the Commission.

Maximizing RF Emission Level:

- (a) The measurements was performed with standard modulation
- (b) Test was performed at listed 3m open area test site (listed with FCC, IC, ITI, NVLAP, ACA & VCCI).
- (c) The transmitter under test was placed at the specified height on a non-conducting turntable (80 cm height)
- (d) The biconilog Antenna (20 MHz to 1 GHz) or Horn Antenna (1 GHz to 18 GHz) was used for measuring.
- (e) The spectrum analyzer was tuned to transmitter carrier frequency. The test antenna was lowered or raised from 1 to 4 meters until the maximum signal level was detected.
- (f) The transmitter was rotated through 360° about a vertical axis until a higher maximum signal was received.

ULTRATECH GROUP OF LABS

3000 Bristol Circle, Oakville, Ontario, Canada L6H 6G4
Tel. #: 905-829-1570, Fax. #: 905-829-8050, Email: vhk.ultratech@sympatico.ca, Website: <http://www.ultratech-labs.com>

File #: FSG27-FTX
March 23, 2001

- Assessed by ITI (UK) Competent Body, NVLAP (USA) Accreditation Body & ACA/AUSTEL (Australia)
- Recognized/Listed by FCC (USA), Industry Canada (Canada)
- All test results contained in this engineering test report are traceable to National Institute of Standards and Technology (NIST)

- (g) The test antenna was lowered or raised again from 1 to 4 meters until a maximum was obtained. This level was recorded.
- (h) The recorded reading was corrected to the true field strength level by adding the antenna factor, cable loss and subtracting the pre-amplifier gain.
- (i) The field strength level measured at 3m is converted to the power in dBm by subtracting a constant factor of 97.5 dB

METHOD OF CALCULATION FOR TRANSMITTED POWER (P) FROM THE MEASURED FIELD STRENGTH LEVEL (E):

According to IEC 801-3, the power density can be calculated as follows:

$$S = P / (4\pi D^2) \quad \text{Where: } S: \text{ Power density in watts per square feet}$$

P : Transmitted power in watts
 π : 3.1415
 D : Distance in meters

The power density S (W/m^2) and electric field E (V/m) is related by:

$$S = E^2 / (120\pi)$$

Accordingly, the field intensity of isotropic radiator in free space can be expressed as follows:

$$E = (30\sqrt{P}) / D = 5.5\sqrt{P} / D$$

For Halfwave dipole antenna or other antennas correlated to dipole in direction of maximum radiation:

$$S = (1.64\sqrt{P}) / (4\pi D^2)$$
$$E = (49.2\sqrt{P}) / D = 7.01\sqrt{P} / D$$

$$P = (E \times D / 7.01)^2$$

Calculation of transmitted power P (dBm) given a measured field intensity E (dBuV/m):

$$\begin{aligned} P(W) &= [E(V/m) \times D / 7.01]^2 \\ P(mW) &= P(W) \times 1000 \\ \Rightarrow P(dBm) &= 10 \log P(mW) \\ &= 20 \log E(V/m) + 20 \log(D) - 20 \log(7.01) + 10 \log 1000 \\ &= E(dBV/m) + 20 \log D + 13 \\ &= E(dBuV/m) - 120 + 20 \log(D) + 13 \\ &= E(dBuV/m) + 20 \log(D) - 107 \end{aligned}$$

The Transmitted Power @ $D = 3$ Meters

$$P(dBm) = E(dBuV/m) - 97.5$$

8.5. TRANSIENT FREQUENCY BEHAVIOR

1. Connect the transmitter under tests as shown in the above block diagram
2. Set the signal generator to the assigned frequency and modulate with a 1 kHz tone at ± 12.5 kHz deviation and its output level to be 50 dB below the transmitter rf output at the test receiver end.
3. Set the horizontal sweep rate on the storage scope to 10 milliseconds per division and adjust the display to continuously view the 1000 Hz tone from the Demodulator Output Port (DOP) of the Test Receiver. Adjust the vertical scale amplitude control of the scope to display the 1000 Hz at ± 4 divisions vertical Center at the display.
4. Adjust the scope so it will trigger on an increasing magnitude from the RF trigger signal of the transmitter under test when the transmitter was turned on. Set the controls to store the display.
5. The output at the DOP, due to the change in the ratio of the power between the signal generator input power and transmitter output power will, because of the capture effect of the test receiver, produce a change in display: For the first part of the sweep it will show the 1 kHz test signal. Then once the receiver's demodulator has been captured by the transmitter power, the display will show the frequency difference from the assigned frequency to the actual transmitter frequency versus time. The instant when the 1 kHz test signal is completely suppressed (including any capture time due to phasing) is considered to be t_{on} . The trace should be maintained within the allowed divisions during the period t_1 and t_2 .
6. During the time from the end of t_2 to the beginning of t_3 the frequency difference should not exceed the limits set by the FCC in Part 90.214 and the outlined in the Carrier Frequency Stability sections. The allowed limit is equal to FCC frequency tolerance limits specified in FCC 90.213.
7. Repeat the above steps when the transmitter was turned off for measuring t_3 .

ULTRATECH GROUP OF LABS

3000 Bristol Circle, Oakville, Ontario, Canada L6H 6G4
Tel. #: 905-829-1570, Fax. #: 905-829-8050, Email: vhk.ultratech@sympatico.ca, Website: <http://www.ultratech-labs.com>

File #: FSG27-FTX
March 23, 2001

- Assessed by ITI (UK) Competent Body, NVLAP (USA) Accreditation Body & ACA/AUSTEL (Australia)
- Recognized/Listed by FCC (USA), Industry Canada (Canada)
- All test results contained in this engineering test report are traceable to National Institute of Standards and Technology (NIST)

EXHIBIT 9. TEST DATA PLOTS

Refer to attached test data plots.

ULTRATECH GROUP OF LABS

3000 Bristol Circle, Oakville, Ontario, Canada L6H 6G4
Tel. #: 905-829-1570, Fax. #: 905-829-8050, Email: vhk.ultratech@sympatico.ca, Website: <http://www.ultratech-labs.com>

File #: FSG27-FTX
March 23, 2001

- Assessed by ITI (UK) Competent Body, NVLAP (USA) Accreditation Body & ACA/AUSTEL (Australia)
- Recognized/Listed by FCC (USA), Industry Canada (Canada)
- *All test results contained in this engineering test report are traceable to National Institute of Standards and Technology (NIST)*

EXHIBIT 10. TEST SETUP PHOTOS

Refer to attached test setup photos.

ULTRATECH GROUP OF LABS

3000 Bristol Circle, Oakville, Ontario, Canada L6H 6G4
Tel. #: 905-829-1570, Fax. #: 905-829-8050, Email: vhk.ultratech@sympatico.ca, Website: <http://www.ultratech-labs.com>

File #: FSG27-FTX
March 23, 2001

- Assessed by ITI (UK) Competent Body, NVLAP (USA) Accreditation Body & ACA/AUSTEL (Australia)
- Recognized/Listed by FCC (USA), Industry Canada (Canada)
- *All test results contained in this engineering test report are traceable to National Institute of Standards and Technology (NIST)*

EXHIBIT 11. EXTERNAL PHOTOS OF EUT

Refer to attached EUT external photos

ULTRATECH GROUP OF LABS

3000 Bristol Circle, Oakville, Ontario, Canada L6H 6G4
Tel. #: 905-829-1570, Fax. #: 905-829-8050, Email: vhk.ultratech@sympatico.ca, Website: <http://www.ultratech-labs.com>

File #: FSG27-FTX
March 23, 2001

- Assessed by ITI (UK) Competent Body, NVLAP (USA) Accreditation Body & ACA/AUSTEL (Australia)
- Recognized/Listed by FCC (USA), Industry Canada (Canada)
- *All test results contained in this engineering test report are traceable to National Institute of Standards and Technology (NIST)*

EXHIBIT 12. INTERNAL PHOTOS OF EUT

Refer to attached EUT internal photos.

ULTRATECH GROUP OF LABS

3000 Bristol Circle, Oakville, Ontario, Canada L6H 6G4
Tel. #: 905-829-1570, Fax. #: 905-829-8050, Email: vhk.ultratech@sympatico.ca, Website: <http://www.ultratech-labs.com>

File #: FSG27-FTX
March 23, 2001

- Assessed by ITI (UK) Competent Body, NVLAP (USA) Accreditation Body & ACA/AUSTEL (Australia)
- Recognized/Listed by FCC (USA), Industry Canada (Canada)
- *All test results contained in this engineering test report are traceable to National Institute of Standards and Technology (NIST)*

EXHIBIT 13. COVER LETTERS

Refer to attached cover letters.

ULTRATECH GROUP OF LABS

3000 Bristol Circle, Oakville, Ontario, Canada L6H 6G4
Tel. #: 905-829-1570, Fax. #: 905-829-8050, Email: vhk.ultratech@sympatico.ca, Website: <http://www.ultratech-labs.com>

File #: FSG27-FTX
March 23, 2001

- Assessed by ITI (UK) Competent Body, NVLAP (USA) Accreditation Body & ACA/AUSTEL (Australia)
- Recognized/Listed by FCC (USA), Industry Canada (Canada)
- *All test results contained in this engineering test report are traceable to National Institute of Standards and Technology (NIST)*

EXHIBIT 14. ATTESTATION STATEMENTS

Refer to attached attestation statement.

ULTRATECH GROUP OF LABS

3000 Bristol Circle, Oakville, Ontario, Canada L6H 6G4
Tel. #: 905-829-1570, Fax. #: 905-829-8050, Email: vhk.ultratech@sympatico.ca, Website: <http://www.ultratech-labs.com>

File #: FSG27-FTX
March 23, 2001

- Assessed by ITI (UK) Competent Body, NVLAP (USA) Accreditation Body & ACA/AUSTEL (Australia)
- Recognized/Listed by FCC (USA), Industry Canada (Canada)
- *All test results contained in this engineering test report are traceable to National Institute of Standards and Technology (NIST)*

EXHIBIT 15. ID LABEL AND LOCATION INFO

Refer to attached FCC ID label and location information.

ULTRATECH GROUP OF LABS

3000 Bristol Circle, Oakville, Ontario, Canada L6H 6G4
Tel. #: 905-829-1570, Fax. #: 905-829-8050, Email: vhk.ultratech@sympatico.ca, Website: <http://www.ultratech-labs.com>

File #: FSG27-FTX
March 23, 2001

- Assessed by ITI (UK) Competent Body, NVLAP (USA) Accreditation Body & ACA/AUSTEL (Australia)
- Recognized/Listed by FCC (USA), Industry Canada (Canada)
- *All test results contained in this engineering test report are traceable to National Institute of Standards and Technology (NIST)*

EXHIBIT 16. BLOCK DIAGRAM

Refer to attached block diagram.

ULTRATECH GROUP OF LABS

3000 Bristol Circle, Oakville, Ontario, Canada L6H 6G4
Tel. #: 905-829-1570, Fax. #: 905-829-8050, Email: vhk.ultratech@sympatico.ca, Website: <http://www.ultratech-labs.com>

File #: FSG27-FTX
March 23, 2001

- Assessed by ITI (UK) Competent Body, NVLAP (USA) Accreditation Body & ACA/AUSTEL (Australia)
- Recognized/Listed by FCC (USA), Industry Canada (Canada)
- *All test results contained in this engineering test report are traceable to National Institute of Standards and Technology (NIST)*

EXHIBIT 17. SCHEMATIC DIAGRAMS

Refer to attached schematic.

ULTRATECH GROUP OF LABS

3000 Bristol Circle, Oakville, Ontario, Canada L6H 6G4
Tel. #: 905-829-1570, Fax. #: 905-829-8050, Email: vhk.ultratech@sympatico.ca, Website: <http://www.ultratech-labs.com>

File #: FSG27-FTX
March 23, 2001

- Assessed by ITI (UK) Competent Body, NVLAP (USA) Accreditation Body & ACA/AUSTEL (Australia)
- Recognized/Listed by FCC (USA), Industry Canada (Canada)
- *All test results contained in this engineering test report are traceable to National Institute of Standards and Technology (NIST)*

EXHIBIT 18. PARTS LIST/TUNE UP INFO

None.

ULTRATECH GROUP OF LABS

3000 Bristol Circle, Oakville, Ontario, Canada L6H 6G4
Tel. #: 905-829-1570, Fax. #: 905-829-8050, Email: vhk.ultratech@sympatico.ca, Website: <http://www.ultratech-labs.com>

File #: FSG27-FTX
March 23, 2001

- Assessed by ITI (UK) Competent Body, NVLAP (USA) Accreditation Body & ACA/AUSTEL (Australia)
- Recognized/Listed by FCC (USA), Industry Canada (Canada)
- *All test results contained in this engineering test report are traceable to National Institute of Standards and Technology (NIST)*

EXHIBIT 19. OPERATIONAL DESCRIPTION

Refer to attached operational description.

ULTRATECH GROUP OF LABS

3000 Bristol Circle, Oakville, Ontario, Canada L6H 6G4
Tel. #: 905-829-1570, Fax. #: 905-829-8050, Email: vhk.ultratech@sympatico.ca, Website: <http://www.ultratech-labs.com>

File #: FSG27-FTX
March 23, 2001

- Assessed by ITI (UK) Competent Body, NVLAP (USA) Accreditation Body & ACA/AUSTEL (Australia)
- Recognized/Listed by FCC (USA), Industry Canada (Canada)
- *All test results contained in this engineering test report are traceable to National Institute of Standards and Technology (NIST)*

EXHIBIT 20. RF EXPOSURE INFO

Refer to User's Manual pages 3 - 4.

ULTRATECH GROUP OF LABS

3000 Bristol Circle, Oakville, Ontario, Canada L6H 6G4
Tel. #: 905-829-1570, Fax. #: 905-829-8050, Email: vhk.ultratech@sympatico.ca, Website: <http://www.ultratech-labs.com>

File #: FSG27-FTX
March 23, 2001

- Assessed by ITI (UK) Competent Body, NVLAP (USA) Accreditation Body & ACA/AUSTEL (Australia)
- Recognized/Listed by FCC (USA), Industry Canada (Canada)
- *All test results contained in this engineering test report are traceable to National Institute of Standards and Technology (NIST)*

EXHIBIT 21. USER'S MANUAL

Refer to attached user's manual.

ULTRATECH GROUP OF LABS

3000 Bristol Circle, Oakville, Ontario, Canada L6H 6G4
Tel. #: 905-829-1570, Fax. #: 905-829-8050, Email: vhk.ultratech@sympatico.ca, Website: <http://www.ultratech-labs.com>

File #: FSG27-FTX
March 23, 2001

- Assessed by ITI (UK) Competent Body, NVLAP (USA) Accreditation Body & ACA/AUSTEL (Australia)
- Recognized/Listed by FCC (USA), Industry Canada (Canada)
- *All test results contained in this engineering test report are traceable to National Institute of Standards and Technology (NIST)*