



MOTOROLA



TESTING CERT: 2518.01

**FCC ID: LO6-DVRS700
DECLARATION OF COMPLIANCE MPE ASSESSMENT**

Networks & Enterprise
EME Test Laboratory
8000 West Sunrise Blvd
Fort Lauderdale, FL. 33322

Date of Report: March 01, 2007
Report Revision: Rev. O
Report ID: FCC MPE rpt_DVR 700 XTL 7800
Rev O_070301_SR2966

Responsible Engineer: Stephen Whalen (EME Principle Staff Eng.)
Date/s Tested: 10/18/05, 11/2/05, 1/30/2007 & 6/23/2006, 8/4/2006 – 8/6/2006
Manufacturer/Location: Futurecom Systems Group Inc., Concord, Ontario, Canada
Date submitted for test: 10/5/05 (DVR)
DUT Description: 700MHz DVRS
Test TX mode(s): CW
Max. Power output: 5W (conducted into antenna), 100% Duty Cycle
TX Frequency Bands: 764 -776MHz and 794-806MHz
Signaling type: FM; APCO 25
Model(s) Tested: DQPM DVR7000P
Model(s) Certified: DQPM DVR7000P
Serial Number(s): 05060955
Classification: Occupational Controlled (Operator); General Population/Uncontrolled (Passengers/Bystanders)
Rule Part(s): 2.1091 (d)



Approved Accessories:
Antenna(s):
HAF4016A (764-870MHz ¼ wave trunk mount antenna; 0dBd gain)

Companion Mobiles and Antennas:

FCC ID	Mobile Description	Antenna(s)
AZ492FT5823	Motorola XTL5000 Model M20URS9PW1AN, 764-870MHz Mobile, Transmit conducted power up to 35W, 50% transmit duty cycle.	HAF4013A (764-870MHz; ¼ wave Roof mount; 3dBd gain); HAF4014A (764-870MHz; ¼ wave Roof mount; 3dBd gain); HAF4016A (764-870MHz; ¼ wave Roof mount; 0dBd gain); HAF4017A (764-870MHz; ¼ wave Roof mount; 3dBd gain)

Final RF Exposure Results:
Combined 700MHz DVR and 7/800 Mobile max calculated power density % of limit = 20.9%

Based on the information and the testing results provided herein, the undersigned certifies that when used as stated in the operating instructions supplied, said product complies with the national and international reference standards and guidelines listed in section 3.0 of this report. This report shall not be reproduced without written approval from an officially designated representative of the Motorola EME Laboratory.

Signature on file
Deanna Zakharia NE EME Lab Senior Resource Manager,
Laboratory Director,

Approval Date: 3/2/07

Certification Date:

Certification No.:

TABLE OF CONTENTS

- 1.0 Product and System Description
- 2.0 Additional Options and Accessories
- 3.0 Measurement and Limit Standards
- 4.0 Data Collection Consideration
- 5.0 Measurement System Uncertainty Levels
- 6.0 Method of Measurement
 - 6.1 DVR 700MHz EME measurements made with trunk mounted antenna(s)
 - 6.1.1 External vehicle EME measurement
 - 6.1.2 Internal vehicle EME measurement
 - 6.2 Mobile 7/800 EME measurements made with roof mounted antenna(s)
 - 6.2.1 External vehicle EME measurements
 - 6.2.2 Internal vehicle EME measurement
- 7.0 Test Site
- 8.0 Measurement System/Equipment
- 9.0 Test Unit Description
- 10.0 Test Set-Up Description
- 11.0 Test Results Summary
- 12.0 Conclusion

- APPENDIX A: Illustration of Antenna Location and Test Distances
- APPENDIX B: Block Diagram of MPE Test Configuration
- APPENDIX C: Meter/Probe Calibration Certificates
- APPENDIX D: Photos of Assessed Antennas
- APPENDIX E: Detailed MPE Measurement Data

REVISION HISTORY

Date	Revision	Comments
03/01/07	O	Original release

1.0 Product and System Description

FCC ID: LO6-DVRS700 is a MOBEXCOM Digital Vehicular Repeater (DVR) manufactured by FUTURECOM Systems Group. The DVR, in addition to standalone operation, is capable of interfacing to a companion mobile radio using serial data protocol for audio and control. The full duplex DVR provides local area coverage for portable to portable communication in the 700MHz band while the companion mobile radio provides wide-area coverage extension.

The system can operate in the following modes: Mobile mode - where the vehicular repeat function is off but receives emergency and mode change commands from portable devices; Local mode - with portable to portable repeat and network monitoring capabilities; and System mode - with portable to portable repeat functions with full network interconnect. Furthermore, the DVRS offers a busy lockout feature where a simulcast prevention algorithm is used for seamless multi-vehicle operation on the same channel. Moreover, the system supports emergency calls in the MDC1200 signaling format. Other system features include field programmability, seamless interface to a mobile radio through the control head bus, controllability via a mobile radio control head, as well as remotely by a dispatcher or portable user. The DVR supports up to 64 channels and 255 talk groups, MDC1200, DTMF, EIA, CCIR signaling as well as PL and DPL. The DVR supports programmability of leading and/or trailing tones, and audio and TX priorities per mode as well as talk group steering.

This test report covers the RF Exposure performance of the 700MHz 5 watts DVR interfaced with, and transmitting simultaneously with, companion 7/800MHz mobile radio with maximum transmit powers up to 36 watts (764-806MHz) and 42 watts (806-870MHz) and with both units installed in a typical vehicle.

The DVR transmit frequency range are 764-776MHz (talk around) and 794-806MHz (repeater) at transmit duty cycle up to 100%. The 7/800MHz mobile transmit frequency range is 764-870MHz at transmit duty cycle up to 50%. The DVR antenna is limited to $\frac{1}{4}\lambda$ (0dBd gain) mounted at the center of the trunk, and the 7/800MHz mobile antennas are limited to $\frac{1}{4}\lambda$ (0dBd and 3dBd gain) mounted at the center of the roof. The maximum conducted power delivered to the DVR antenna is 5 watts.

This device will be marketed to and used by employees solely for work-related operations, such as public safety agencies, e.g. police, fire and emergency medical. User training is the responsibility of these agencies which can be expected to employ the usage instructions, safety information and operational cautions set forth in the user's manual, instructional sessions or other means.

Accordingly this product is classified as Occupational/Controlled Exposure. However, In accordance with FCC requirements, the passengers inside the vehicle and the bystanders external to the vehicle are evaluated to the General Population/Uncontrolled Exposure Limits.

(Note that "By-standers" as used herein mean people other than operator)

2.0 Additional Options and Accessories:

NA

3.0 Measurement and Limit Standards

Measurements were performed according to the recommended guidelines in IEEE/ANSI C95.3-2002 and compared to FCC Limits Per 47 CFR 2.1091 (d) for General Population/Uncontrolled RF Exposure.

For test frequencies ranging from 764-806MHz and 764-870MHz the MPE (Maximum Permissible Exposure) limit to electromagnetic energy in equivalent plane wave free-space power density is 0.51-0.54mW/cm² and 0.51–0.58mW/cm² respectively and calculated using the formula $f/1500$.

4.0 Data Collection Consideration

Power density testing was performed with DUT installed in a 1991 Ford Taurus (4-door). Measurement data was taken with the vehicles’ electrical system powered by an equivalent source equal to the car running at idle and the vehicle battery measuring 13.8-14.0 volts.

5.0 Measurement System Uncertainty Levels

The information below presents an estimate of the possible errors that are associated with the measurement system.

Uncertainty Budget for Near Field Probe Measurements

	Tol. (± %)	Prob. Dist.	Divisor	u_i (±%)
Measurement System				
Survey Meter Calibration	3.0	N	1.00	3.0
Repeatability Accuracy	7.0	N	1.00	7.0
Combined Standard Uncertainty		RSS		7.6
Expanded Uncertainty		$k=2$		15

6.0 Method of Measurement

MPE measurements were conducted for each transmitter individually per the procedures described in the following sections. Percent of Limit was calculated for each transmitter individually for each position. Final results representing the maximum combined exposure of DVR and mobile radio were obtained by summing the highest percent of limit results from each transmitter.

6.1 DVR 700MHz EME measurements made with trunk mounted antenna(s)
(For reference, see Illustration of antenna location and test distances in APPENDIX A)

6.1.1 External vehicle EME measurement
(Antenna mounted at trunk center)

MPE measurements for by-stander conditions are determined by taking the average of (10) measurements in a 2m vertical line for each of the (5) test locations indicated in APPENDIX A with 20cm increments at the test distance of 60cm from the test vehicle's body, as stated in the user manual. The measurement probe sensor is rotated 180° at each of the ten incremental measurements to ensure the highest result is captured. These measurements are representative of persons other than the operator standing next to the vehicle.

The DVR antenna mounted at the center of the trunk was assessed across the TX band for the (5) by-stander conditions presented in APPENDIX A.

6.1.2 Internal vehicle EME measurement
(Antenna mounted at trunk center)

While rotating survey meter probe through 180 degrees to ensure that the highest level is found, scans were performed inside of the vehicle, at both front and back seating areas, across the TX band to ascertain the highest level at the head. After the highest level is found, scans were performed vertically making two (2) additional measurements within an area approximately 40cm wide (representing the width of a person) so as to have a total of three (3) measured points, indicated below, that are averaged.

- a) Head area
- b) Chest area
- c) Lower Trunk area

6.2 Mobile 7/800MHz EME measurements made with roof mounted antenna(s)
(For reference, see Illustration of antenna location and test distances in APPENDIX A).

6.2.1 External vehicle EME measurement
(Antenna mounted at roof center)

MPE measurements for by-stander conditions are determined by taking the average of (10) measurements in a 2m vertical line for each of the (5) test locations indicated in APPENDIX A with 20cm increments at the test distance of 60cm from the test vehicle's body, as stated in the user manual. The measurement probe sensor is rotated 180° at each of the ten incremental measurements to ensure the highest result is captured. These measurements are representative of persons other than the operator standing next to the vehicle.

The mobile antennas mounted at the center of the roof were assessed across the TX band for the (5) by-stander conditions presented in APPENDIX A.

6.2.2 Internal vehicle EME measurement
(Antenna mounted at roof center)

While rotating survey meter probe through 180 degrees to ensure that the highest level is found, scans were performed inside of the vehicle, both at the front and back seating areas, across the TX band to ascertain the highest level in each location. After the highest level is found, two (2) additional measurements were performed vertically within an area approximately 40cm wide (representing the width of a person) so as to have a total of three (3) measured points as indicated below that are averaged.

- a) Head area
- b) Chest area
- c) Lower Trunk area

7.0 Test Site

The test site is the Motorola open area test site located at 8000 W. Sunrise Blvd., Plantation, FL. 33322.

8.0 Measurement System/Equipment

Equipment Type	Model #	SN	Calibration Due Date
Automobile	1991 Ford Taurus, 4-Door		
*Survey Meter	NARDA Model 8718	01108	5/17/06
*Probe - E-Field (Electric Field)	NARDA Model 8722B	13001	7/21/06
**Survey Meter	NARDA Model 8718	01108	7/11/07
**Probe – E-Field (Electric Field)	NARDA Model 8722B	13001	7/11/07
***Survey Meter	NARDA Model 8718	01122	4/20/07
***Probe – E-Field (Electric Field)	NARDA Model 8722B	12023	4/20/07

* Equipment used during DVR 700MHz Passenger (test dates 10/18/2005, 11/2/2005)

** Equipment used during DVR 700MHz By-stander (test dates 1/30/2007)

*** Equipment used during 7/800MHz mobile (test date 6/23/2006, 8/4/2006 – 8/6/2006)

9.0 Test Unit Description

Power density measurements were performed on a representative sample of the DVR 700MHz 5 watt radio with serial number 05060955.

Power density measurements were performed on the following representative sample of the Motorola XTL5000 7/800MHz 36 watts (764-806MHz) and 42 watts (806-870MHz) radio with serial number CAM0305RXK.

Presented below is a summary of the tested frequencies and associated power outputs for each DUT.

DVR DQPM DVR7000P	
Frequency (MHz)	Po (W)
764	4.99
770	5.02
776	4.97
794	4.98
800	5.00
806	4.98

Mobile M20URS9PW1AN	
Frequency (MHz)	Po (W)
764.0875	36.0
773.0125	36.0
775.9125	36.1
794.0875	37.0
809.0125	41.3
823.9875	41.6
851.0125	41.9
859.0125	41.7
868.9875	41.9

10.0 Test Set-Up Description

The following are the mobile antenna test configurations used for this product.
(for reference, see Illustration of antenna location and test distances in the APPENDIX A)

Mobile - The ¼ wave antennas (HAF4013A 3dBd, HAF4014A 3dBd, HAF4016A 0dBd and HAF4017A 3dBd) were assessed while mounted at the center of the roof of the test vehicle.

DVR - The ¼ wave antenna (HAF4016A 0dBd) was assessed while mounted at the trunk.

Assessments were made internal and external to the test vehicle at the specified distances and test locations indicated in sections 6.0, 11.0, and the APPENDIX A.

11.0 Test Results Summary

APPENDIX E presents detailed MPE measurement information for each test configuration; person external or internal to the vehicle, TX frequency, antenna (location, model and gain), distance from antenna to probe sensor, E field measurements, calibration factor, MPE average over body, initial power, power density calc, power density max calc, IEEE/FCC controlled and uncontrolled limits, and maximum output power.

The Average over Body test methodology is consistent with IEEE/ANSI C95.3-2002 guidelines

MPE results are based on a DVR 100% duty cycle and Mobile 50% duty cycle which is in accordance with the User Manual instructions.

Below is an explanation of how the MPE results are calculated.

External to vehicle - 10 measurements are averaged over the body (*Body_Avg*).

Internal to vehicle - 3 measurements are averaged over the body (*Body_Avg*).

Narda Survey Meter measures in percent of the controlled limit. Therefore the averages over the body used in the calculations below reflect percentages.

Therefore;

$$\text{Average_over_Body} = \text{Body_Avg} * \text{Controlled_Limit}$$

$$\text{Pwr_Density_Calc} = \text{Average_over_Body} * \text{Duty_Cycle}$$

$$\text{Pwr_Density_Max_Calc} = \text{Pwr_Density_Calc} * \frac{\text{Max_Output_Power}}{\text{Initial_Output_Power}}$$

Note; For Initial Output Power > Max_Output_Power, Max_Output_Power / Initial Output Power = 1

The tables below summarize the highest MPE results of the E field test configurations for the 7/800MHz mobile, DVR 700MHz, and combined assessments. See APPENDICES A and E respectively for the indicated test locations and detailed MPE measurement data.

Table 1 – 7/800MHz mobile M20URS9PW1AN Assessments – Highest MPE result per test position

Tables	Antenna Model	Antenna Location	Test Frequency (MHz)	E/H Field	Passenger/By-Stander Pos.	Max Calc Pwr Density (mW/cm ²)	% of Uncontrolled limit
Table 22	HAF4014A	Roof	773.0125	E	Passenger	0.05	9.6%
Table 21	HAF4014A	Roof	773.0125	E	By-Stander Pos. #1	0.06	11.5%
Table 86	HAF4014A	Roof	809.0125	E	By-Stander Pos. #2	0.06	11.1%
Table 140	HAF4017A	Roof	809.0125	E	By-Stander Pos. #3	0.03	5.6%
Table 154	HAF4014A	Roof	764.0875	E	By-Stander Pos. #4	0.03	5.9%
Table 191	HAF4014A	Roof	773.0125	E	By-Stander Pos. #5	0.03	5.8%

Table 2 – DVR 700MHz DQPM-DVR7000P Assessments - Highest MPE result per test position

Tables	Antenna Model	Antenna Location	Test Frequency (MHz)	E/H Field	Passenger/By-Stander Pos.	Max Calc Pwr Density (mW/cm ²)	% of Uncontrolled limit
Table 10	HAF4016A	Trunk	800	E	Passenger	0.06	11.3%
Table 11	HAF4016A	Trunk	806	E	By-Stander Pos. #1	0.03	5.6%
Table 17	HAF4016A	Trunk	800	E	By-Stander Pos. #2	0.03	5.7%
Table 19	HAF4016A	Trunk	764	E	By-Stander Pos. #3	0.04	7.8%
Table 29	HAF4016A	Trunk	800	E	By-Stander Pos. #4	0.05	9.4%
Table 35	HAF4016A	Trunk	800	E	By-Stander Pos. #5	0.07	13.2%

**Table 3 - Combined 7/800MHz mobile M20URS9PW1AN and DVR 700MHz DQPM DVR7000P
(Calculated % of limit performance)**

Test Position	Percentage of Limit		
	7/800MHz Mobile (764-870MHz)	DVR 700MHz (764-806MHz)	Combined Percentages
Passenger	9.6%	11.3%	20.9%
By-Stander #1	11.5%	5.6%	17.1%
By-Stander #2	11.1%	5.7%	16.8%
By-Stander #3	5.6%	7.8%	13.4%
By-Stander #4	5.9%	9.4%	15.3%
By-Stander #5	5.8%	13.2%	19.0%

12.0 Conclusion

Because the signals emitted by each individual transmitter are statistically uncorrelated, the collective compliance of the transmitters is determined by summing the individual ratios between actual (S) and maximum allowed MPE exposure. Compliance is achieved if the total exposure level (T) is less than one:

Formula:

$$T = \frac{S_1}{MPE_1} + \frac{S_2}{MPE_2} + \dots < 1$$

Depending on the test frequency, the mobile assessments were performed with an output power range of 36.0W – 41.9W. The DVR output power range across the TX band is 4.97 – 5.02W. The highest power density results for the XTL5000 7/800MHz mobile device scaled to the maximum allowable power output is 0.05mW/cm² internal to the vehicle and 0.06mW/cm² external to the vehicle. The highest power density results for the DVR 700MHz device scaled to the maximum allowable power output is 0.06mW/cm² internal to the vehicle and 0.07mW/cm² external to the vehicle. The highest combined passenger power density performance is 20.9% and highest combined by-stander power density performance is 19.0% (refer to table 3 test position 5) of the FCC/IEEE MPE limits using the methodology and formula below.

Therefore:

Passenger $T = \frac{0.05}{0.52} + \frac{0.06}{0.53} = 0.209 < 1$ (compliant)

By-stander $T = \frac{0.03}{0.52} + \frac{0.07}{0.53} = 0.190 < 1$ (compliant)

The MPE results presented herein demonstrate compliance to the applicable FCC/IEEE Occupational/Controlled exposure limit of 2.55-2.69mW/cm² for the 764-806MHz frequency range and 2.55-2.90mW/cm² for the 764-870MHz frequency range. FCC/IEEE Occupational/Controlled exposure limits are calculated by f/300 for the frequency range of 300-1500MHz.

Compliance to the FCC/IEEE General population/Uncontrolled exposure limits of 0.51-0.54mW/cm² for the frequency range of 764-806MHz and 0.51-0.58mW/cm² for frequency range of 764-870MHz, using formula $f/1500$, is demonstrated herein for both passengers and bystanders.

APPENDIX A

Illustration of Antenna Locations and Test Distances

Illustration of Antenna Locations and Test Distances

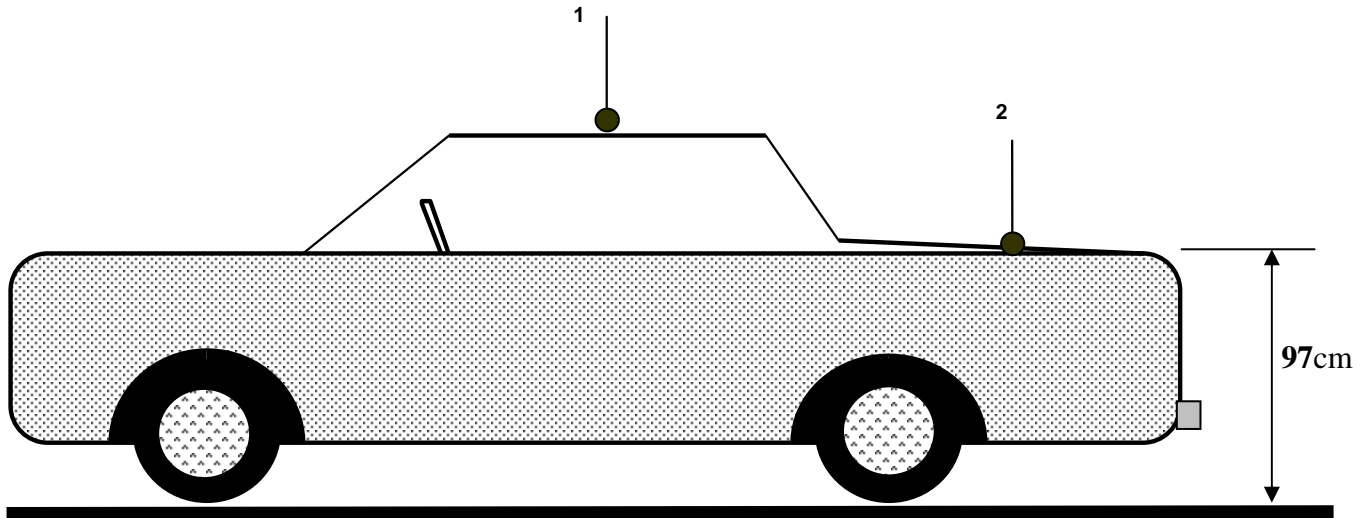

1 - Roof (center)
2 - Trunk (center)

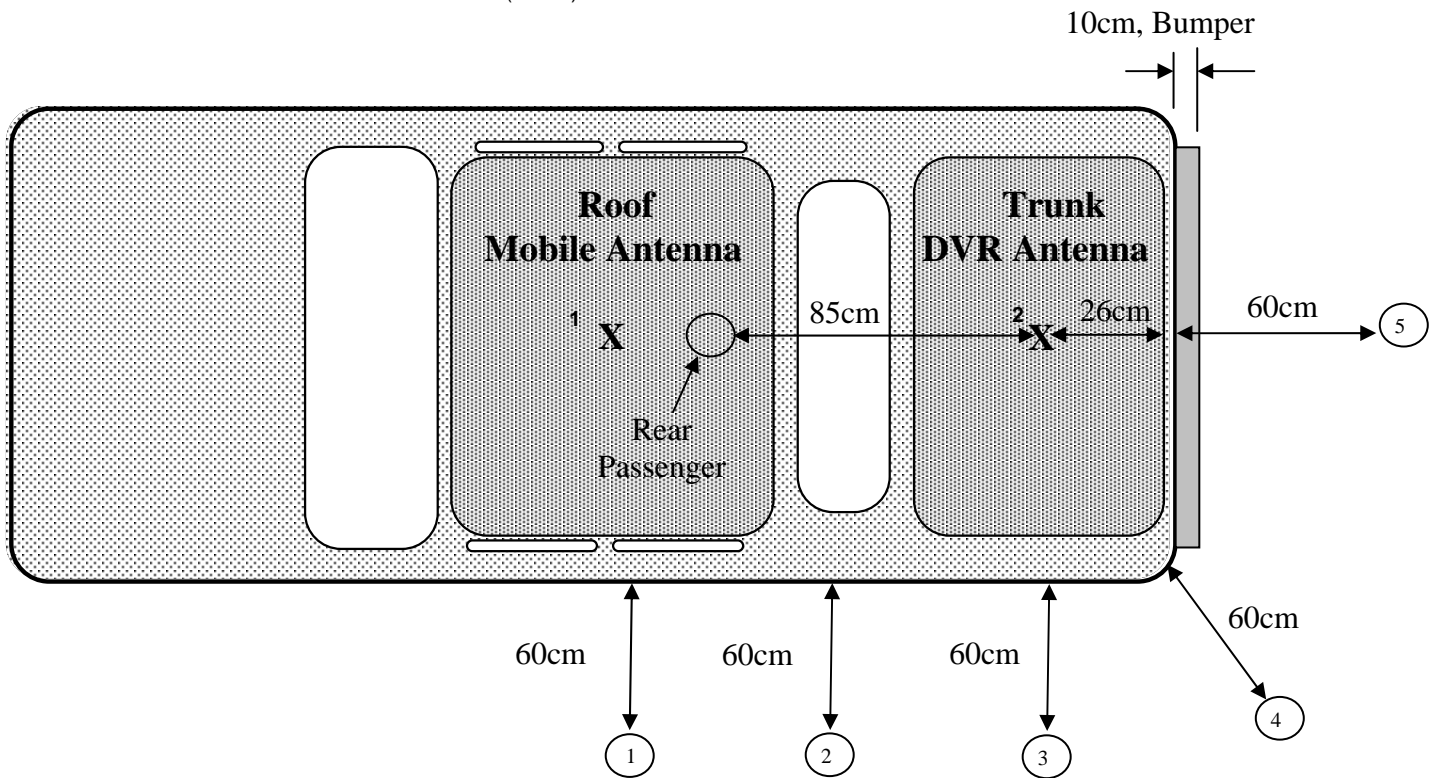

Notes

- 1) Assessments were performed at each test position for each offered antenna
- 2) By-stander positions (1-5) are 60cm from the vehicle body
- 3) By-stander position 2 is located at the mid point between the two antennas
- 4) Total distance between by-stander position 1 and roof mount antenna is 157cm
- 5) Total distance between by-stander position 5 and trunk mount antenna is 97cm
- 6) Total distance between trunk mount antenna and rear passenger is 85cm

APPENDIX B

Block Diagram of MPE Test Configuration

MPE Test Configuration

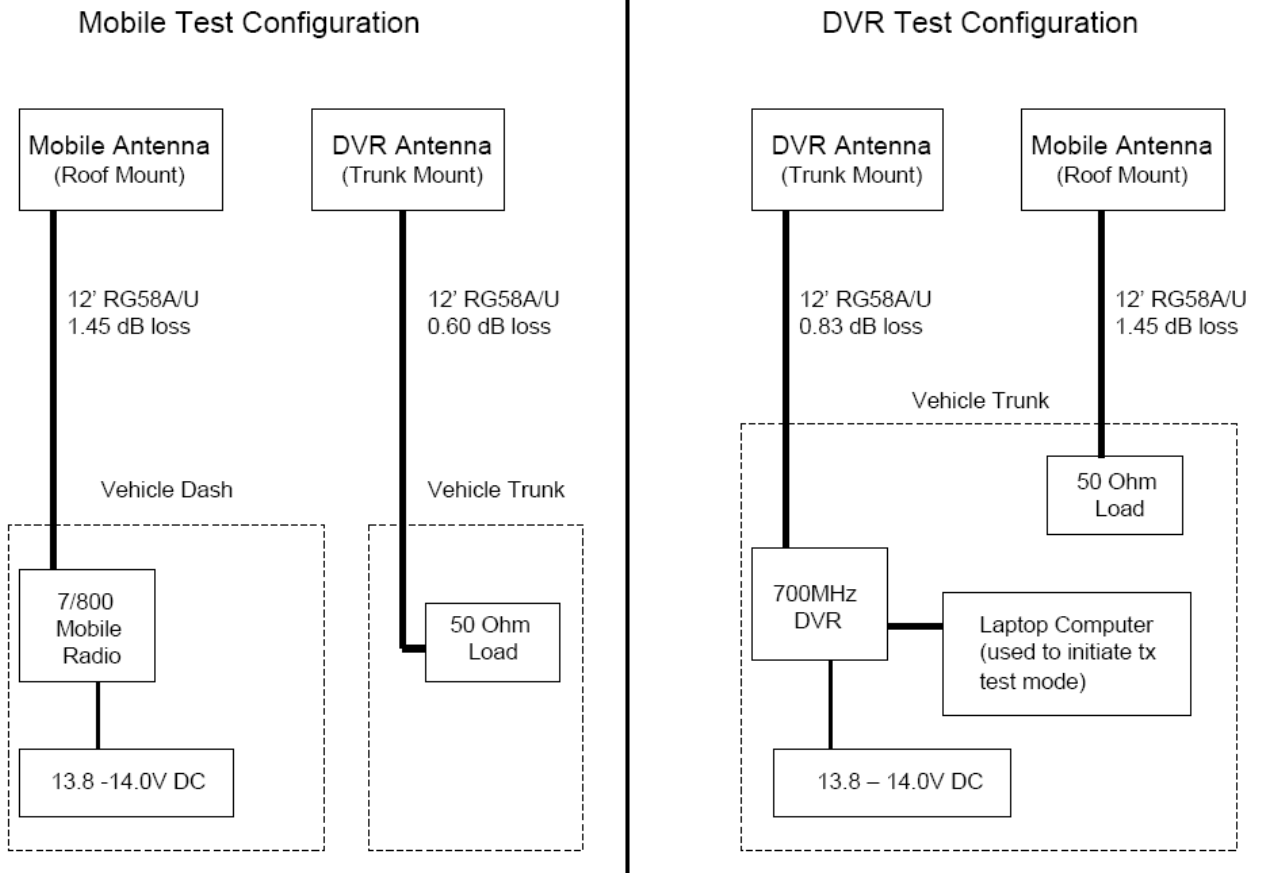

APPENDIX C

Meter/Probe Calibration Certificates



NARDA MICROWAVE-EAST
CALIBRATED IN ACCORDANCE
WITH ANSI Z540
CAL DATE 5-17-06 BY [Signature]
CAL DUE 5-17-06
MOD. 8718-10 SN. 01108

Certificate of Calibration

L-3 Communications, Narda Microwave-East, hereby certifies that the referenced RF Radiation Hazard monitoring equipment has been calibrated in accordance with MIL-STD-45662A, ANSI Z540, ISO 10012 and ISO 9001: 2000.

The measured values were determined by comparison with our standards, which are traceable to the National Institute of Standards and Technology to the extent allowed by NIST's calibration facilities.

Customer: MOTOROLA Certificate #: 56219 1
SCHAUMBURG, IL 60168-0429
Model #: 8718-10 Serial #: 01108
Description: METER W/CABLE PO #: NP1819669
Date Calibrated: 05/17/2005 R.O. #: 56219

Vince Donovan
Vince Donovan
Manager of Instruments Assembly and Test

John C. Stine
John C. Stine
Director of Quality Assurance

This certificate shall not be reproduced, except in full, without written approval from L-3 Communications, Narda Microwave-East



Certificate of Calibration

L-3 Communications, Narda Microwave-East, hereby certifies that the referenced RF Radiation Hazard monitoring equipment has been calibrated in accordance with MIL-STD-45662A, ANSI Z540, ISO 10012 and ISO 9001: 2000.

The measured values were determined by comparison with our standards, which are traceable to the National Institute of Standards and Technology to the extent allowed by NIST's calibration facilities.

Customer: MOTOROLA
SCHAUMBURG, IL 60168-0429

Certificate #: 57518 1

Model #: 8722B
Description: PROBE
Date Calibrated: 07/21/2005

Serial #: 13001
PO #: NP1900854
R.O. #: 57518

Vince Donovan
Manager of Instruments Assembly and Test

John C. Stine
Director of Quality Assurance

This certificate shall not be reproduced, except in full, without written approval from L-3 Communications, Narda Microwave-East



DATE 21-Jul-2005
REL HUMIDITY 40%

RELEASE # R57518
TEMP 21 DEG. C

NARDA MICROWAVE - EAST

MODEL # 8722B
SERIAL # 13001

Recal Probe - Date of Previous Probe Data = 06/10/2004

FREQ MHZ	PRE-CAL DATA	FINAL CAL DATA	ELLIPSE RATIO, dB	FINAL CORR. FACTOR	DEVIATION DELTA DB	PREVIOUS FINAL COF
.30	0.78	0.74	+/- 0.71	1.34	-0.29	1.21
3.00	1.36	1.30	+/- 0.47	0.77	-0.12	0.72
10.00	1.01	0.97	+/- 0.48	1.03	+0.43	1.09
30.00	0.80	0.77	+/- 0.44	1.30	+0.47	1.39
100.00	1.30	1.24	+/- 0.32	0.80	+0.18	0.81
300.00	0.93	0.89	+/- 0.16	1.13	+0.25	1.14
750.00	1.15	1.10	+/- 0.13	0.91	+0.95	1.09
1000.00	1.30	1.25	+/- 0.30	0.80	+1.09	0.99
1700.00	0.91	0.87	+/- 0.38	1.14	+1.03	1.39
2450.00	1.23	1.24	+/- 0.34	0.81	+1.07	1.04
4000.00	0.87	0.88	+/- 0.35	1.13	0.00	1.15
8200.00	1.06	1.07	+/- 0.45	0.93	0.00	0.94
10000.00	1.02	1.03	+/- 0.54	0.97	+0.05	1.00
18000.00	1.19	1.20	+/- 0.76	0.83	-0.22	0.80
26500.00	1.04	1.05	+/- 0.87	0.95	-0.17	0.93
40000.00	0.80	0.81	+/- 0.75	1.24	-0.04	1.25

LOW FREQUENCY MULTIPLIER = 0.96 HIGH FREQUENCY MULTIPLIER = 1.013

FREQ. DEV. (3-40000 MHZ) = 2.288 DB

FREQ. DEV. (0.3-40000 MHZ) = 2.43 DB

MAX. ELLIPSE RATIO (0.3-40000 MHZ) = +/- 0.87 DB

PRE-CAL DATA REFLECTS THE MEAN ELLIPSE RATIO OF PROBE AS RECEIVED BY

NARDA CALIBRATION DEPARTMENT, OR IS THE INITIAL, UN-ADJUSTED RATIO.

(PRE-CAL x OLD CORR. FACTOR) - 1 = DEVIATION FROM PREVIOUS (OLD)

CALIBRATION DATA. NOTE: NOT APPLICABLE FOR NEW PROBES.

FINAL CAL DATA IS THE RATIO OF THE DISPLAYED TO THE APPLIED FIELD STRENGTH.

FINAL CORR. FACTOR IS THE RECIPROCAL OF FINAL CAL DATA.

FINAL CORR. FACTOR MULTIPLIED BY THE DISPLAYED FIELD STRENGTH READING

GIVES THE ACTUAL ("CORRECTED") FIELD STRENGTH.

ELLIPSE RATIO IS EXPRESSED IN dB DEVIATION FROM THE MEAN DATA

RMS Uncertainty = +/- 0.5db. ATP # = 502120 REV 3

TESTER V. M.

Q.A. APPROVAL [Stamp]



CERTIFICATION OF CALIBRATION CONFORMANCE

LIBERTY LABS, INC. 1346 Yellowwood Road Kimballton, IA 51543
EMAIL: mhoward@liberty-labs.com TEL: (712) 773-2199 FAX: (712)773-2299

This probe has been individually calibrated using IEEE Standard for Calibration of Electromagnetic Field Sensors and Probes, Excluding Antennas, from 9 kHz to 40 GHz; IEEE Std. 1309-1996. All results of this calibration relate only to the items that were calibrated.

ACCREDITATION NOTES:

A complete copy of the scope of our A2LA accreditation is available upon request.

Instrumentation Environment: TEMP: 23°C RH: 41%
Calibration Environment: TEMP: 23°C RH: 41%

Barometric Pressure (inches): 29.82

CERTIFICATE NO.: 2006061922

CLIENT: Motorola, Inc., 8000 W. Sunrise Blvd., Plantation, FL, 33322-9947, USA

MANUFACTURER: Narda

MODEL NUMBER: 8722B & 8718

SERIAL NUMBER: 13001 & 01108

ASSET NUMBER:

DATE OF CALIBRATION: Tuesday, July 11, 2006

NAME OF CALIBRATING ORGANIZATION Liberty Labs, Inc.

CALIBRATED BY: DSG *DSG*

RE-CERTIFICATION DATE: Re-Certification interval is at customer discretion.

RECEIVED STATUS

Received in tolerance:

RETURNED STATUS

Returned in tolerance:

Returned limited cal.:

NOTES: We have deviated from IEEE 1309 with the use of a tri-plate line as a transfer standard for frequencies at and/or below 1GHz. Client declined isotropic response testing. In/Out of tolerance based on alignment/mounting position and not on manufacturer's specifications. A probe position document is included with this certificate.



This report is not to be reproduced, except in full, without written approval of Liberty Labs, Inc.

Michael W. Howard

ENGINEER IN CHARGE
MICHAEL W. HOWARD
NARTE CERTIFIED EMC ENGINEER, NO. EM C-000102-NE



Certificate Number: 2123.01

Rev. D: Issue Date 12/12/03

ispb-position

Probe01.txt

Date of Calibration: 11-July-2006
 Date Printed: Tuesday, July 11, 2006
 Customer Name: Motorola, Inc.
 Probe Manufacturer: Narda
 Probe Model: 8722B & 8718
 Probe Serial No.: 13001 & 01108
 Temperature (Deg C): 23
 Humidity (%): 41
 Notes: Calibrated with 8718 Monitor, s/n 01108.
 CAL CERT #: 2006061922

Frequency in MHz	Correction Factors	
	Mutiplier	dB
1	1.91	5.62
15	1.23	1.82
30	0.89	-1.04
75	0.82	-1.74
100	0.71	-3.02
150	1.04	0.36
200	0.90	-0.88
300	0.73	-2.79
400	0.92	-0.75
500	1.08	0.70
600	1.35	2.62
700	0.86	-1.29
800	1.06	0.47
900	1.58	3.97
1000	0.68	-3.38
2000	1.10	0.80
2450	0.95	-0.49
3000	0.90	-0.91
4000	1.29	2.22
5000	0.90	-0.92
6000	0.84	-1.52
7000	0.98	-0.15



Certificate of Calibration

L-3 Communications, Narda Microwave-East, hereby certifies that the referenced RF Radiation Hazard monitoring equipment has been calibrated in accordance with MIL-STD-45662A, ANSI Z540, ISO 10012 and ISO 9001: 2000.

The measured values were determined by comparison with our standards, which are traceable to the National Institute of Standards and Technology to the extent allowed by NIST's calibration facilities.

Customer:	MOTOROLA	Certificate #:	64777 1
	SCHAUMBURG, IL 60168-0429		
Model #:	8718-10	Serial #:	01122
Description:	METER W/CABLE	PO #:	NP2398645
Date Calibrated:	04/20/2006	R.O. #:	64777

 Vince Donovan
 Manufacturing

 Ken Peck
 Quality Assurance

This certificate shall not be reproduced, except in full, without written approval from L-3 Communications, Narda Microwave-East



Certificate of Calibration

L-3 Communications, Narda Microwave-East, hereby certifies that the referenced RF Radiation Hazard monitoring equipment has been calibrated in accordance with MIL-STD-45662A, ANSI Z540, ISO 10012 and ISO 9001 : 2000.

The measured values were determined by comparison with our standards, which are traceable to the National Institute of Standards and Technology to the extent allowed by NIST's calibration facilities.

Customer: **MOTOROLA**
SCHAUMBURG, IL 60168-0429

Certificate #: 64777 2

Model #: 8722B

Serial #: 12023

Description: PROBE

PO #: NP2398645

Date Calibrated: 04/20/2006

R.O. #: 64777

 Vince Donovan
 Manufacturing

 Ken Peck
 Quality Assurance

This certificate shall not be reproduced, except in full, without written approval from L-3 Communications, Narda Microwave-East



DATE 20-Apr-2006
REL HUMIDITY 46%

RELEASE # R64777
TEMP 21 DEG. C

NARDA MICROWAVE - EAST

MODEL # 8722B
SERIAL # 12023

FREQ MHZ	PRE-CAL DATA	FINAL CAL DATA	ELLIPSE RATIO, dB	FINAL CORR. FACTOR
.30	0.81	0.78	+/- 0.24	1.28
3.00	1.27	1.23	+/- 0.38	0.81
10.00	0.76	0.74	+/- 0.23	1.35
30.00	0.65	0.63	+/- 0.13	1.58
100.00	1.17	1.14	+/- 0.22	0.88
300.00	0.90	0.87	+/- 0.34	1.14
750.00	1.31	1.27	+/- 0.30	0.79
1000.00	1.63	1.58	+/- 0.35	0.63
1700.00	1.00	0.97	+/- 0.48	1.03
2450.00	1.35	1.37	+/- 0.45	0.73
4000.00	0.92	0.93	+/- 0.43	1.07
8200.00	1.05	1.07	+/- 0.46	0.94
10000.00	1.05	1.07	+/- 0.42	0.94
18000.00	1.17	1.19	+/- 0.75	0.84
26500.00	0.93	0.94	+/- 0.83	1.07
40000.00	0.72	0.73	+/- 0.67	1.37

LOW FREQUENCY MULTIPLIER = 0.972 HIGH FREQUENCY MULTIPLIER = 1.014
 FREQ. DEV. (3-40000 MHZ) = 3.993 DB
 FREQ. DEV. (0.3-40000 MHZ) = 3.99 DB
 MAX. ELLIPSE RATIO (0.3-40000 MHZ) = +/- 0.83 DB
 PRE-CAL DATA REFLECTS THE MEAN ELLIPSE RATIO OF PROBE AS RECEIVED BY
 NARDA CALIBRATION DEPARTMENT, OR IS THE INITIAL, UN-ADJUSTED RATIO.
 (PRE-CAL x OLD CORR. FACTOR) - 1 = DEVIATION FROM PREVIOUS (OLD)
 CALIBRATION DATA. NOTE: NOT APPLICABLE FOR NEW PROBES.
 FINAL CAL DATA IS THE RATIO OF THE DISPLAYED TO THE APPLIED FIELD STRENGTH.
 FINAL CORR. FACTOR IS THE RECIPROCAL OF FINAL CAL DATA.
 FINAL CORR. FACTOR MULTIPLIED BY THE DISPLAYED FIELD STRENGTH READING
 GIVES THE ACTUAL ("CORRECTED") FIELD STRENGTH.
 ELLIPSE RATIO IS EXPRESSED IN dB DEVIATION FROM THE MEAN DATA
 RMS Uncertainty = +/- 0.5db. ATP # = 502120 REVJ

TESTER

L-V

Q.A. APPROVAL



APPENDIX D

Photos of Assessed Antennas



DVR

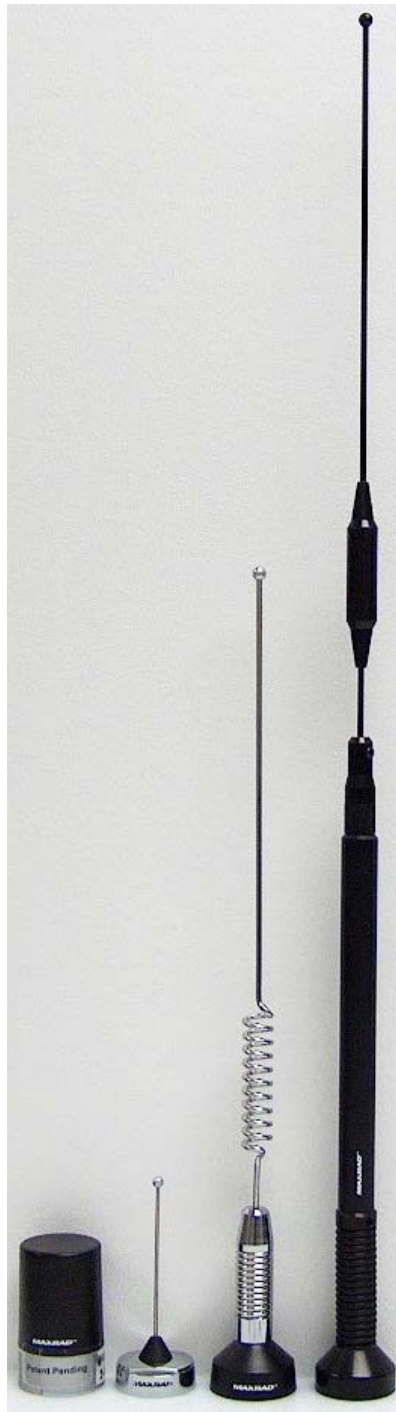

XTL5000

Antenna kit numbers, from left to right;
DVR HAF4016A, XTL5000 HAF4013A, HAF4016A, HAF4014A, HAF4017A

APPENDIX E
Detailed MPE Measurement Data

700MHz DVR DQPM DVR7000P

BS-Position 1

Table 1

External Vehicle MPE Assessment @ 764 MHz									
Antenna Location	Antenna Model	Gain (dBi)	Meas. Distance (cm)	E/H Field	Calibration Factor	Average over Body (mW/cm ²)	Initial Power (W)	Pwr. Density Calc. (mW/cm ²)	Pwr. Density Max Calc. (mW/cm ²)
Trunk (cnt)	HAF4016A	2.15	60	E	0.99	0.009	5.00	0.009	0.01
Measurement Grid									
Test Position	Height (cm)	% of Control Limit		Test Position	Height (cm)	% of Control Limit		IEEE Controlled Limit	IEEE Uncontrolled Limit
1	20	0.3%		6	120	0.3%		2.55	0.51
2	40	0.2%		7	140	0.4%			
3	60	0.2%		8	160	0.5%			
4	80	0.3%		9	180	0.5%			
5	100	0.3%		10	200	0.5%			
								RF Po (*Max)	5.00

P-Position 1

Table 2

Internal Vehicle MPE Assessment @ 764 MHz										
Antenna Location	Antenna	Gain (dBi)	Meas. Distance (cm)	E/H Field	Calibration Factor	Average over Head, Chest, Lower Trunk Back/Front seats (mW/cm ²)		Initial Power (W)	Pwr. Density Calc. (mW/cm ²)	Pwr. Density Max Calc. (mW/cm ²)
						Back	Front			
Trunk (cnt)	HAF4016A	2.15	Highest Reading	E	0.9	0.042	0.025	4.99	0.042	0.04
Measurement Grid										
Test Position		% of Control Limit Head		% of Control Limit Chest		% of Control Limit Lower Trunk		IEEE Controlled Limit:		2.55
Back Seat		1.6%		1.7%		1.6%		IEEE Uncontrolled Limit:		0.51
Front Seat		1.0%		1.0%		1.0%		RF Po (*Max):		5.00

BS-Position 1

Table 3

External Vehicle MPE Assessment @ 770 MHz									
Antenna Location	Antenna Model	Gain (dBi)	Meas. Distance (cm)	E/H Field	Calibration Factor	Average over Body (mW/cm ²)	Initial Power (W)	Pwr. Density Calc. (mW/cm ²)	Pwr. Density Max Calc. (mW/cm ²)
Trunk (cnt)	HAF4016A	2.15	60	E	1.00	0.011	5.00	0.011	0.01
Measurement Grid									
Test Position	Height (cm)	% of Control Limit		Test Position	Height (cm)	% of Control Limit		IEEE Controlled Limit	IEEE Uncontrolled Limit
1	20	0.3%		6	120	0.7%		2.57	0.51
2	40	0.2%		7	140	0.5%			
3	60	0.2%		8	160	0.5%			
4	80	0.3%		9	180	0.5%			
5	100	0.5%		10	200	0.6%			
								RF Po (*Max)	5.00

700MHz DVR DQPM DVR7000P

P-Position 1

Table 4

Internal Vehicle MPE Assessment @ 770 MHz										
Antenna Location	Antenna	Gain (dBi)	Meas. Distance (cm)	E/H Field	Calibration Factor	Average over Head, Chest, Lower Trunk Back/Front seats (mW/cm ²)		Initial Power (W)	Pwr. Density Calc. (mW/cm ²)	Pwr. Density Max Calc. (mW/cm ²)
						Back	Front			
Trunk (cnt)	HAF4016A	2.15	Highest Reading	E	0.9	0.040	0.022	5.02	0.040	0.04
Measurement Grid										
Test Position	% of Control Limit Head		% of Control Limit Chest		% of Control Limit Lower Trunk		IEEE Controlled Limit:		2.57	
Back Seat	1.9%		1.8%		1.0%		IEEE Uncontrolled Limit:		0.51	
Front Seat	1.1%		0.7%		0.8%		RF Po (*Max):		5.00	

BS-Position 1

Table 5

External Vehicle MPE Assessment @ 776 MHz									
Antenna Location	Antenna Model	Gain (dBi)	Meas. Distance (cm)	E/H Field	Calibration Factor	Average over Body (mW/cm ²)	Initial Power (W)	Pwr. Density Calc. (mW/cm ²)	Pwr. Density Max Calc. (mW/cm ²)
Trunk (cnt)	HAF4016A	2.15	60	E	1.01	0.008	5.00	0.008	0.01
Measurement Grid									
Test Position	Height (cm)	% of Control Limit		Test Position	Height (cm)	% of Control Limit		IEEE Controlled Limit	IEEE Uncontrolled Limit
1	20	0.3%		6	120	0.3%		2.59	0.52
2	40	0.2%		7	140	0.3%			
3	60	0.3%		8	160	0.2%			
4	80	0.3%		9	180	0.3%			
5	100	0.2%		10	200	0.7%			

P-Position 1

Table 6

Internal Vehicle MPE Assessment @ 776 MHz										
Antenna Location	Antenna	Gain (dBi)	Meas. Distance (cm)	E/H Field	Calibration Factor	Average over Head, Chest, Lower Trunk Back/Front seats (mW/cm ²)		Initial Power (W)	Pwr. Density Calc. (mW/cm ²)	Pwr. Density Max Calc. (mW/cm ²)
						Back	Front			
Trunk (cnt)	HAF4016A	2.15	Highest Reading	E	0.9	0.049	0.025	4.97	0.049	0.05
Measurement Grid										
Test Position	% of Control Limit Head		% of Control Limit Chest		% of Control Limit Lower Trunk		IEEE Controlled Limit:		2.59	
Back Seat	2.5%		2.3%		0.9%		IEEE Uncontrolled Limit:		0.52	
Front Seat	1.1%		0.9%		0.9%		RF Po (*Max):		5.00	

700MHz DVR DQPM DVR7000P

BS-Position 1

Table 7

External Vehicle MPE Assessment @ 794 MHz									
Antenna Location	Antenna Model	Gain (dBi)	Meas. Distance (cm)	E/H Field	Calibration Factor	Average over Body (mW/cm ²)	Initial Power (W)	Pwr. Density Calc. (mW/cm ²)	Pwr. Density Max Calc. (mW/cm ²)
Trunk (cnt)	HAF4016A	2.15	60	E	1.05	0.017	5.00	0.017	0.02
Measurement Grid									
Test Position	Height (cm)	% of Control Limit		Test Position	Height (cm)	% of Control Limit		IEEE Controlled Limit	IEEE Uncontrolled Limit
1	20	0.5%		6	120	0.9%		2.65	0.53
2	40	0.2%		7	140	0.7%		RF Po (*Max)	5.00
3	60	0.6%		8	160	0.6%			
4	80	0.7%		9	180	0.7%			
5	100	0.6%		10	200	0.8%			

P-Position 1

Table 8

Internal Vehicle MPE Assessment @ 794 MHz										
Antenna Location	Antenna	Gain (dBi)	Meas. Distance (cm)	E/H Field	Calibration Factor	Average over Head, Chest, Lower Trunk Back/Front seats (mW/cm ²)		Initial Power (W)	Pwr. Density Calc. (mW/cm ²)	Pwr. Density Max Calc. (mW/cm ²)
						Back	Front			
Trunk (cnt)	HAF4016A	2.15	Highest Reading	E	0.89	0.051	0.021	4.98	0.051	0.05
Measurement Grid										
Test Position		% of Control Limit Head		% of Control Limit Chest		% of Control Limit Lower Trunk		IEEE Controlled Limit:		2.65
Back Seat		2.6%		1.8%		1.4%		IEEE Uncontrolled Limit:		0.53
Front Seat		0.9%		0.9%		0.6%		RF Po (*Max):		5.00

BS-Position 1

Table 9

External Vehicle MPE Assessment @ 800 MHz									
Antenna Location	Antenna Model	Gain (dBi)	Meas. Distance (cm)	E/H Field	Calibration Factor	Average over Body (mW/cm ²)	Initial Power (W)	Pwr. Density Calc. (mW/cm ²)	Pwr. Density Max Calc. (mW/cm ²)
Trunk (cnt)	HAF4016A	2.15	60	E	1.06	0.018	4.97	0.018	0.02
Measurement Grid									
Test Position	Height (cm)	% of Control Limit		Test Position	Height (cm)	% of Control Limit		IEEE Controlled Limit	IEEE Uncontrolled Limit
1	20	0.5%		6	120	0.7%		2.67	0.53
2	40	0.6%		7	140	0.7%		RF Po (*Max)	5.00
3	60	0.7%		8	160	0.7%			
4	80	0.8%		9	180	0.7%			
5	100	0.7%		10	200	0.6%			

700MHz DVR DQPM DVR7000P

P-Position 1

Table 10

Internal Vehicle MPE Assessment @ 800 MHz										
Antenna Location	Antenna	Gain (dBi)	Meas. Distance (cm)	E/H Field	Calibration Factor	Average over Head, Chest, Lower Trunk Back/Front seats (mW/cm ²)		Initial Power (W)	Pwr. Density Calc. (mW/cm ²)	Pwr. Density Max Calc. (mW/cm ²)
						Back	Front			
Trunk (cnt)	HAF4016A	2.15	Highest Reading	E	0.89	0.060	0.024	5.00	0.060	0.06
Measurement Grid										
Test Position	% of Control Limit Head		% of Control Limit Chest		% of Control Limit Lower Trunk		IEEE Controlled Limit:		2.67	
Back Seat	3.2%		1.9%		1.6%		IEEE Uncontrolled Limit:		0.53	
Front Seat	0.9%		1.1%		0.7%		RF Po (*Max):		5.00	

BS-Position 1

Table 11

External Vehicle MPE Assessment @ 806 MHz										
Antenna Location	Antenna Model	Gain (dBi)	Meas. Distance (cm)	E/H Field	Calibration Factor	Average over Body (mW/cm ²)	Initial Power (W)	Pwr. Density Calc. (mW/cm ²)	Pwr. Density Max Calc. (mW/cm ²)	
Trunk (cnt)	HAF4016A	2.15	60	E	1.09	0.028	4.98	0.028	0.03	
Measurement Grid										
Test Position	Height (cm)	% of Control Limit		Test Position	Height (cm)	% of Control Limit		IEEE Controlled Limit	IEEE Uncontrolled Limit	
1	20	0.5%		6	120	1.9%		2.69	0.54	
2	40	0.4%		7	140	1.0%				
3	60	1.1%		8	160	0.9%				
4	80	1.7%		9	180	0.9%				
5	100	1.1%		10	200	1.1%				
								RF Po (*Max):		5.00

P-Position 1

Table 12

Internal Vehicle MPE Assessment @ 806 MHz										
Antenna Location	Antenna	Gain (dBi)	Meas. Distance (cm)	E/H Field	Calibration Factor	Average over Head, Chest, Lower Trunk Back/Front seats (mW/cm ²)		Initial Power (W)	Pwr. Density Calc. (mW/cm ²)	Pwr. Density Max Calc. (mW/cm ²)
						Back	Front			
Trunk (cnt)	HAF4016A	2.15	Highest Reading	E	0.89	0.061	0.025	4.98	0.061	0.06
Measurement Grid										
Test Position	% of Control Limit Head		% of Control Limit Chest		% of Control Limit Lower Trunk		IEEE Controlled Limit:		2.69	
Back Seat	2.9%		2.2%		1.7%		IEEE Uncontrolled Limit:		0.54	
Front Seat	1.0%		1.0%		0.8%		RF Po (*Max):		5.00	

700MHz DVR DQPM DVR7000P

BS-Position 2

Table 13

External Vehicle MPE Assessment @ 764 MHz									
Antenna Location	Antenna Model	Gain (dBi)	Meas. Distance (cm)	E/H Field	Calibration Factor	Average over Body (mW/cm ²)	Initial Power (W)	Pwr. Density Calc. (mW/cm ²)	Pwr. Density Max Calc. (mW/cm ²)
Trunk (cnt)	HAF4016A	2.15	60	E	0.99	0.022	5.00	0.022	0.02
Measurement Grid									
Test Position	Height (cm)	% of Control Limit		Test Position	Height (cm)	% of Control Limit		IEEE Controlled Limit	IEEE Uncontrolled Limit
1	20	0.3%		6	120	1.1%		2.55	0.51
2	40	0.4%		7	140	1.2%			
3	60	0.5%		8	160	1.3%			
4	80	0.6%		9	180	1.3%			
5	100	0.6%		10	200	1.3%			
								RF Po (*Max)	5.00

BS-Position 2

Table 14

External Vehicle MPE Assessment @ 770 MHz									
Antenna Location	Antenna Model	Gain (dBi)	Meas. Distance (cm)	E/H Field	Calibration Factor	Average over Body (mW/cm ²)	Initial Power (W)	Pwr. Density Calc. (mW/cm ²)	Pwr. Density Max Calc. (mW/cm ²)
Trunk (cnt)	HAF4016A	2.15	60	E	1.00	0.023	5.00	0.023	0.02
Measurement Grid									
Test Position	Height (cm)	% of Control Limit		Test Position	Height (cm)	% of Control Limit		IEEE Controlled Limit	IEEE Uncontrolled Limit
1	20	0.6%		6	120	1.2%		2.57	0.51
2	40	0.3%		7	140	1.2%			
3	60	0.8%		8	160	0.8%			
4	80	0.8%		9	180	1.3%			
5	100	0.9%		10	200	1.2%			
								RF Po (*Max)	5.00

BS-Position 2

Table 15

External Vehicle MPE Assessment @ 776 MHz									
Antenna Location	Antenna Model	Gain (dBi)	Meas. Distance (cm)	E/H Field	Calibration Factor	Average over Body (mW/cm ²)	Initial Power (W)	Pwr. Density Calc. (mW/cm ²)	Pwr. Density Max Calc. (mW/cm ²)
Trunk (cnt)	HAF4016A	2.15	60	E	1.01	0.021	5.00	0.021	0.02
Measurement Grid									
Test Position	Height (cm)	% of Control Limit		Test Position	Height (cm)	% of Control Limit		IEEE Controlled Limit	IEEE Uncontrolled Limit
1	20	0.7%		6	120	1.1%		2.59	0.52
2	40	0.3%		7	140	1.1%			
3	60	0.6%		8	160	0.9%			
4	80	0.7%		9	180	1.0%			
5	100	0.9%		10	200	1.0%			
								RF Po (*Max)	5.00

700MHz DVR DQPM DVR7000P

BS-Position 2

Table 16

External Vehicle MPE Assessment @ 794 MHz										
Antenna Location	Antenna Model	Gain (dBi)	Meas. Distance (cm)	E/H Field	Calibration Factor	Average over Body (mW/cm ²)	Initial Power (W)	Pwr. Density Calc. (mW/cm ²)	Pwr. Density Max Calc. (mW/cm ²)	
Trunk (cnt)	HAF4016A	2.15	60	E	1.05	0.025	5.00	0.025	0.02	
Measurement Grid										
Test Position	Height (cm)	% of Control Limit		Test Position	Height (cm)	% of Control Limit		IEEE Controlled Limit	IEEE Uncontrolled Limit	
1	20	0.3%		6	120	1.3%		2.65	0.53	
2	40	0.3%		7	140	1.3%				
3	60	0.6%		8	160	1.2%				
4	80	1.0%		9	180	1.2%				
5	100	1.1%		10	200	1.1%				
								RF Po (*Max)		5.00

BS-Position 2

Table 17

External Vehicle MPE Assessment @ 800 MHz										
Antenna Location	Antenna Model	Gain (dBi)	Meas. Distance (cm)	E/H Field	Calibration Factor	Average over Body (mW/cm ²)	Initial Power (W)	Pwr. Density Calc. (mW/cm ²)	Pwr. Density Max Calc. (mW/cm ²)	
Trunk (cnt)	HAF4016A	2.15	60	E	1.06	0.030	4.97	0.030	0.03	
Measurement Grid										
Test Position	Height (cm)	% of Control Limit		Test Position	Height (cm)	% of Control Limit		IEEE Controlled Limit	IEEE Uncontrolled Limit	
1	20	0.7%		6	120	1.5%		2.67	0.53	
2	40	0.4%		7	140	1.5%				
3	60	0.8%		8	160	1.2%				
4	80	1.3%		9	180	1.1%				
5	100	1.2%		10	200	1.5%				
								RF Po (*Max)		5.00

BS-Position 2

Table 18

External Vehicle MPE Assessment @ 806 MHz										
Antenna Location	Antenna Model	Gain (dBi)	Meas. Distance (cm)	E/H Field	Calibration Factor	Average over Body (mW/cm ²)	Initial Power (W)	Pwr. Density Calc. (mW/cm ²)	Pwr. Density Max Calc. (mW/cm ²)	
Trunk (cnt)	HAF4016A	2.15	60	E	1.09	0.032	4.98	0.032	0.03	
Measurement Grid										
Test Position	Height (cm)	% of Control Limit		Test Position	Height (cm)	% of Control Limit		IEEE Controlled Limit	IEEE Uncontrolled Limit	
1	20	0.8%		6	120	1.7%		2.69	0.54	
2	40	0.6%		7	140	1.5%				
3	60	0.7%		8	160	1.4%				
4	80	1.2%		9	180	1.2%				
5	100	1.6%		10	200	1.3%				
								RF Po (*Max)		5.00

700MHz DVR DQPM DVR7000P

BS-Position 3

Table 19

External Vehicle MPE Assessment @ 764 MHz									
Antenna Location	Antenna Model	Gain (dBi)	Meas. Distance (cm)	E/H Field	Calibration Factor	Average over Body (mW/cm ²)	Initial Power (W)	Pwr. Density Calc. (mW/cm ²)	Pwr. Density Max Calc. (mW/cm ²)
Trunk (cnt)	HAF4016A	2.15	60	E	0.99	0.035	4.95	0.035	0.04
Measurement Grid									
Test Position	Height (cm)	% of Control Limit		Test Position	Height (cm)	% of Control Limit		IEEE Controlled Limit	IEEE Uncontrolled Limit
1	20	1.0%		6	120	1.6%		2.55	0.51
2	40	0.6%		7	140	3.2%			
3	60	0.7%		8	160	1.6%			
4	80	1.0%		9	180	1.5%			
5	100	1.1%		10	200	1.5%			
								RF Po (*Max)	5.00

BS-Position 3

Table 20

External Vehicle MPE Assessment @ 770 MHz									
Antenna Location	Antenna Model	Gain (dBi)	Meas. Distance (cm)	E/H Field	Calibration Factor	Average over Body (mW/cm ²)	Initial Power (W)	Pwr. Density Calc. (mW/cm ²)	Pwr. Density Max Calc. (mW/cm ²)
Trunk (cnt)	HAF4016A	2.15	60	E	1.00	0.030	5.00	0.030	0.03
Measurement Grid									
Test Position	Height (cm)	% of Control Limit		Test Position	Height (cm)	% of Control Limit		IEEE Controlled Limit	IEEE Uncontrolled Limit
1	20	0.9%		6	120	1.4%		2.57	0.51
2	40	0.7%		7	140	1.8%			
3	60	0.8%		8	160	1.4%			
4	80	1.0%		9	180	1.3%			
5	100	1.2%		10	200	1.1%			
								RF Po (*Max)	5.00

BS-Position 3

Table 21

External Vehicle MPE Assessment @ 776 MHz									
Antenna Location	Antenna Model	Gain (dBi)	Meas. Distance (cm)	E/H Field	Calibration Factor	Average over Body (mW/cm ²)	Initial Power (W)	Pwr. Density Calc. (mW/cm ²)	Pwr. Density Max Calc. (mW/cm ²)
Trunk (cnt)	HAF4016A	2.15	60	E	1.01	0.033	4.95	0.033	0.03
Measurement Grid									
Test Position	Height (cm)	% of Control Limit		Test Position	Height (cm)	% of Control Limit		IEEE Controlled Limit	IEEE Uncontrolled Limit
1	20	0.9%		6	120	1.5%		2.59	0.52
2	40	0.6%		7	140	2.6%			
3	60	0.8%		8	160	1.4%			
4	80	1.3%		9	180	1.3%			
5	100	1.2%		10	200	1.1%			
								RF Po (*Max)	5.00

700MHz DVR DQPM DVR7000P

BS-Position 3

Table 22

External Vehicle MPE Assessment @ 794 MHz									
Antenna Location	Antenna Model	Gain (dBi)	Meas. Distance (cm)	E/H Field	Calibration Factor	Average over Body (mW/cm ²)	Initial Power (W)	Pwr. Density Calc. (mW/cm ²)	Pwr. Density Max Calc. (mW/cm ²)
Trunk (cnt)	HAF4016A	2.15	60	E	1.05	0.043	5.00	0.043	0.04
Measurement Grid									
Test Position	Height (cm)	% of Control Limit		Test Position	Height (cm)	% of Control Limit		IEEE Controlled Limit	IEEE Uncontrolled Limit
1	20	1.0%		6	120	2.3%		2.65	0.53
2	40	0.6%		7	140	3.4%			
3	60	0.8%		8	160	1.7%			
4	80	1.7%		9	180	1.5%			
5	100	1.8%		10	200	1.3%			
								RF Po (*Max)	5.00

BS-Position 3

Table 23

External Vehicle MPE Assessment @ 800 MHz									
Antenna Location	Antenna Model	Gain (dBi)	Meas. Distance (cm)	E/H Field	Calibration Factor	Average over Body (mW/cm ²)	Initial Power (W)	Pwr. Density Calc. (mW/cm ²)	Pwr. Density Max Calc. (mW/cm ²)
Trunk (cnt)	HAF4016A	2.15	60	E	1.06	0.043	4.97	0.043	0.04
Measurement Grid									
Test Position	Height (cm)	% of Control Limit		Test Position	Height (cm)	% of Control Limit		IEEE Controlled Limit	IEEE Uncontrolled Limit
1	20	1.1%		6	120	1.8%		2.67	0.53
2	40	0.8%		7	140	4.0%			
3	60	0.9%		8	160	1.7%			
4	80	1.5%		9	180	1.5%			
5	100	1.7%		10	200	1.3%			
								RF Po (*Max)	5.00

BS-Position 3

Table 24

External Vehicle MPE Assessment @ 806 MHz									
Antenna Location	Antenna Model	Gain (dBi)	Meas. Distance (cm)	E/H Field	Calibration Factor	Average over Body (mW/cm ²)	Initial Power (W)	Pwr. Density Calc. (mW/cm ²)	Pwr. Density Max Calc. (mW/cm ²)
Trunk (cnt)	HAF4016A	2.15	60	E	1.09	0.040	4.98	0.040	0.04
Measurement Grid									
Test Position	Height (cm)	% of Control Limit		Test Position	Height (cm)	% of Control Limit		IEEE Controlled Limit	IEEE Uncontrolled Limit
1	20	1.1%		6	120	2.1%		2.69	0.54
2	40	0.5%		7	140	3.0%			
3	60	0.8%		8	160	1.6%			
4	80	1.3%		9	180	1.3%			
5	100	1.9%		10	200	1.1%			
								RF Po (*Max)	5.00

700MHz DVR DQPM DVR7000P

BS-Position 4

Table 25

External Vehicle MPE Assessment @ 764 MHz									
Antenna Location	Antenna Model	Gain (dBi)	Meas. Distance (cm)	E/H Field	Calibration Factor	Average over Body (mW/cm ²)	Initial Power (W)	Pwr. Density Calc. (mW/cm ²)	Pwr. Density Max Calc. (mW/cm ²)
Trunk (cnt)	HAF4016A	2.15	60	E	0.99	0.045	5.00	0.045	0.04
Measurement Grid									
Test Position	Height (cm)	% of Control Limit		Test Position	Height (cm)	% of Control Limit		IEEE Controlled Limit	IEEE Uncontrolled Limit
1	20	1.4%		6	120	2.8%		2.55	0.51
2	40	1.0%		7	140	2.4%			
3	60	0.8%		8	160	2.0%			
4	80	1.8%		9	180	1.8%			
5	100	2.2%		10	200	1.4%			
								RF Po (*Max)	5.00

BS-Position 4

Table 26

External Vehicle MPE Assessment @ 770 MHz									
Antenna Location	Antenna Model	Gain (dBi)	Meas. Distance (cm)	E/H Field	Calibration Factor	Average over Body (mW/cm ²)	Initial Power (W)	Pwr. Density Calc. (mW/cm ²)	Pwr. Density Max Calc. (mW/cm ²)
Trunk (cnt)	HAF4016A	2.15	60	E	1.00	0.040	5.00	0.040	0.04
Measurement Grid									
Test Position	Height (cm)	% of Control Limit		Test Position	Height (cm)	% of Control Limit		IEEE Controlled Limit	IEEE Uncontrolled Limit
1	20	0.6%		6	120	2.5%		2.57	0.51
2	40	1.0%		7	140	2.0%			
3	60	0.8%		8	160	1.8%			
4	80	1.8%		9	180	1.6%			
5	100	2.2%		10	200	1.4%			
								RF Po (*Max)	5.00

BS-Position 4

Table 27

External Vehicle MPE Assessment @ 776 MHz									
Antenna Location	Antenna Model	Gain (dBi)	Meas. Distance (cm)	E/H Field	Calibration Factor	Average over Body (mW/cm ²)	Initial Power (W)	Pwr. Density Calc. (mW/cm ²)	Pwr. Density Max Calc. (mW/cm ²)
Trunk (cnt)	HAF4016A	2.15	60	E	1.01	0.036	5.00	0.036	0.04
Measurement Grid									
Test Position	Height (cm)	% of Control Limit		Test Position	Height (cm)	% of Control Limit		IEEE Controlled Limit	IEEE Uncontrolled Limit
1	20	1.2%		6	120	2.1%		2.59	0.52
2	40	0.8%		7	140	1.8%			
3	60	0.8%		8	160	1.6%			
4	80	1.3%		9	180	1.3%			
5	100	2.0%		10	200	1.0%			
								RF Po (*Max)	5.00

700MHz DVR DQPM DVR7000P

BS-Position 4

Table 28

External Vehicle MPE Assessment @ 794 MHz									
Antenna Location	Antenna Model	Gain (dBi)	Meas. Distance (cm)	E/H Field	Calibration Factor	Average over Body (mW/cm ²)	Initial Power (W)	Pwr. Density Calc. (mW/cm ²)	Pwr. Density Max Calc. (mW/cm ²)
Trunk (cnt)	HAF4016A	2.15	60	E	1.05	0.049	5.00	0.049	0.05
Measurement Grid									
Test Position	Height (cm)	% of Control Limit		Test Position	Height (cm)	% of Control Limit		IEEE Controlled Limit	IEEE Uncontrolled Limit
1	20	1.6%		6	120	2.5%		2.65	0.53
2	40	1.1%		7	140	2.8%			
3	60	1.1%		8	160	2.3%			
4	80	1.5%		9	180	2.0%			
5	100	2.2%		10	200	1.5%			
								RF Po (*Max)	5.00

BS-Position 4

Table 29

External Vehicle MPE Assessment @ 800 MHz									
Antenna Location	Antenna Model	Gain (dBi)	Meas. Distance (cm)	E/H Field	Calibration Factor	Average over Body (mW/cm ²)	Initial Power (W)	Pwr. Density Calc. (mW/cm ²)	Pwr. Density Max Calc. (mW/cm ²)
Trunk (cnt)	HAF4016A	2.15	60	E	1.06	0.053	4.97	0.053	0.05
Measurement Grid									
Test Position	Height (cm)	% of Control Limit		Test Position	Height (cm)	% of Control Limit		IEEE Controlled Limit	IEEE Uncontrolled Limit
1	20	1.3%		6	120	3.1%		2.67	0.53
2	40	0.8%		7	140	3.1%			
3	60	1.1%		8	160	2.2%			
4	80	2.0%		9	180	1.7%			
5	100	2.9%		10	200	1.6%			
								RF Po (*Max)	5.00

BS-Position 4

Table 30

External Vehicle MPE Assessment @ 806 MHz									
Antenna Location	Antenna Model	Gain (dBi)	Meas. Distance (cm)	E/H Field	Calibration Factor	Average over Body (mW/cm ²)	Initial Power (W)	Pwr. Density Calc. (mW/cm ²)	Pwr. Density Max Calc. (mW/cm ²)
Trunk (cnt)	HAF4016A	2.15	60	E	1.09	0.049	4.98	0.049	0.05
Measurement Grid									
Test Position	Height (cm)	% of Control Limit		Test Position	Height (cm)	% of Control Limit		IEEE Controlled Limit	IEEE Uncontrolled Limit
1	20	1.5%		6	120	3.1%		2.69	0.54
2	40	1.0%		7	140	2.5%			
3	60	1.0%		8	160	2.0%			
4	80	2.1%		9	180	1.5%			
5	100	2.2%		10	200	1.2%			
								RF Po (*Max)	5.00

700MHz DVR DQPM DVR7000P

BS-Position 5

Table 31

External Vehicle MPE Assessment @ 764 MHz										
Antenna Location	Antenna Model	Gain (dBi)	Meas. Distance (cm)	E/H Field	Calibration Factor	Average over Body (mW/cm ²)	Initial Power (W)	Pwr. Density Calc. (mW/cm ²)	Pwr. Density Max Calc. (mW/cm ²)	
Trunk (cnt)	HAF4016A	2.15	60	E	0.99	0.053	5.00	0.053	0.05	
Measurement Grid										
Test Position	Height (cm)	% of Control Limit		Test Position	Height (cm)	% of Control Limit		IEEE Controlled Limit	IEEE Uncontrolled Limit	
1	20	2.1%		6	120	3.3%		2.55	0.51	
2	40	1.0%		7	140	2.9%				
3	60	1.1%		8	160	2.0%				
4	80	2.4%		9	180	1.6%				
5	100	3.2%		10	200	1.3%				
								RF Po (*Max)		5.00

BS-Position 5

Table 32

External Vehicle MPE Assessment @ 770 MHz										
Antenna Location	Antenna Model	Gain (dBi)	Meas. Distance (cm)	E/H Field	Calibration Factor	Average over Body (mW/cm ²)	Initial Power (W)	Pwr. Density Calc. (mW/cm ²)	Pwr. Density Max Calc. (mW/cm ²)	
Trunk (cnt)	HAF4016A	2.15	60	E	1.00	0.048	5.00	0.048	0.05	
Measurement Grid										
Test Position	Height (cm)	% of Control Limit		Test Position	Height (cm)	% of Control Limit		IEEE Controlled Limit	IEEE Uncontrolled Limit	
1	20	1.3%		6	120	3.7%		2.57	0.51	
2	40	0.8%		7	140	2.4%				
3	60	1.0%		8	160	1.8%				
4	80	2.2%		9	180	1.3%				
5	100	3.1%		10	200	1.1%				
								RF Po (*Max)		5.00

BS-Position 5

Table 33

External Vehicle MPE Assessment @ 776 MHz										
Antenna Location	Antenna Model	Gain (dBi)	Meas. Distance (cm)	E/H Field	Calibration Factor	Average over Body (mW/cm ²)	Initial Power (W)	Pwr. Density Calc. (mW/cm ²)	Pwr. Density Max Calc. (mW/cm ²)	
Trunk (cnt)	HAF4016A	2.15	60	E	1.01	0.047	5.00	0.047	0.05	
Measurement Grid										
Test Position	Height (cm)	% of Control Limit		Test Position	Height (cm)	% of Control Limit		IEEE Controlled Limit	IEEE Uncontrolled Limit	
1	20	1.1%		6	120	2.9%		2.59	0.52	
2	40	0.8%		7	140	2.4%				
3	60	1.1%		8	160	1.9%				
4	80	2.1%		9	180	1.5%				
5	100	3.3%		10	200	1.1%				
								RF Po (*Max)		5.00

700MHz DVR DQPM DVR7000P

BS-Position 5

Table 34

External Vehicle MPE Assessment @ 794 MHz										
Antenna Location	Antenna Model	Gain (dBi)	Meas. Distance (cm)	E/H Field	Calibration Factor	Average over Body (mW/cm ²)	Initial Power (W)	Pwr. Density Calc. (mW/cm ²)	Pwr. Density Max Calc. (mW/cm ²)	
Trunk (cnt)	HAF4016A	2.15	60	E	1.05	0.065	5.00	0.065	0.07	
Measurement Grid										
Test Position	Height (cm)	% of Control Limit		Test Position	Height (cm)	% of Control Limit		IEEE Controlled Limit	IEEE Uncontrolled Limit	
1	20	1.3%		6	120	3.6%		2.65	0.53	
2	40	0.8%		7	140	3.2%				
3	60	1.5%		8	160	3.2%				
4	80	2.8%		9	180	2.3%				
5	100	4.3%		10	200	1.7%				
								RF Po (*Max)		5.00

BS-Position 5

Table 35

External Vehicle MPE Assessment @ 800 MHz										
Antenna Location	Antenna Model	Gain (dBi)	Meas. Distance (cm)	E/H Field	Calibration Factor	Average over Body (mW/cm ²)	Initial Power (W)	Pwr. Density Calc. (mW/cm ²)	Pwr. Density Max Calc. (mW/cm ²)	
Trunk (cnt)	HAF4016A	2.15	60	E	1.06	0.065	4.97	0.065	0.07	
Measurement Grid										
Test Position	Height (cm)	% of Control Limit		Test Position	Height (cm)	% of Control Limit		IEEE Controlled Limit	IEEE Uncontrolled Limit	
1	20	1.1%		6	120	3.0%		2.67	0.53	
2	40	0.9%		7	140	3.2%				
3	60	1.5%		8	160	3.2%				
4	80	2.9%		9	180	2.4%				
5	100	4.5%		10	200	1.8%				
								RF Po (*Max)		5.00

BS-Position 5

Table 36

External Vehicle MPE Assessment @ 806 MHz										
Antenna Location	Antenna Model	Gain (dBi)	Meas. Distance (cm)	E/H Field	Calibration Factor	Average over Body (mW/cm ²)	Initial Power (W)	Pwr. Density Calc. (mW/cm ²)	Pwr. Density Max Calc. (mW/cm ²)	
Trunk (cnt)	HAF4016A	2.15	60	E	1.09	0.059	4.98	0.059	0.06	
Measurement Grid										
Test Position	Height (cm)	% of Control Limit		Test Position	Height (cm)	% of Control Limit		IEEE Controlled Limit	IEEE Uncontrolled Limit	
1	20	1.3%		6	120	2.7%		2.69	0.54	
2	40	0.9%		7	140	2.7%				
3	60	1.3%		8	160	2.8%				
4	80	3.0%		9	180	2.1%				
5	100	3.3%		10	200	1.9%				
								RF Po (*Max)		5.00

7/800MHz Mobile M20URS9PW1AN

BS-Position 1

Table 1

External Vehicle MPE Assessment @ 764.0875 MHz									
Antenna Location	Antenna Model	Gain (dBi)	Meas. Distance (cm)	E/H Field	Calibration Factor	Average over Body (mW/cm ²)	Initial Power (W)	Pwr. Density Calc. (mW/cm ²)	Pwr. Density Max Calc. (mW/cm ²)
Roof (cnt)	HAF4016A	2.15	60	E	0.78	0.077	36.0	0.038	0.04
Measurement Grid									
Test Position	Height (cm)	% of Control Limit		Test Position	Height (cm)	% of Control Limit		IEEE Controlled Limit	IEEE Uncontrolled Limit
1	20	0.6%		6	120	2.4%		2.55	0.51
2	40	0.8%		7	140	3.7%			
3	60	0.9%		8	160	6.4%			
4	80	0.7%		9	180	6.8%			
5	100	1.2%		10	200	6.6%			

P-Position 1

Table 2

Internal Vehicle MPE Assessment @ 764.0875 MHz										
Antenna Location	Antenna	Gain (dBi)	Meas. Distance (cm)	E/H Field	Calibration Factor	Average over Head, Chest, Lower Trunk Back/Front seats (mW/cm ²)		Initial Power (W)	Pwr. Density Calc. (mW/cm ²)	Pwr. Density Max Calc. (mW/cm ²)
						Back	Front			
Roof (cnt)	HAF4016A	2.15	Highest Reading	E	0.78	0.059	0.032	36.0	0.030	0.03
Measurement Grid										
Test Position		% of Control Limit Head		% of Control Limit Chest		% of Control Limit Lower Trunk		IEEE Controlled Limit:		2.55
Back Seat		2.2%		2.9%		1.9%		IEEE Uncontrolled Limit:		0.51
Front Seat		1.8%		1.0%		1.0%		RF Po (*Max):		36.0

BS-Position 1

Table 3

External Vehicle MPE Assessment @ 773.0125 MHz									
Antenna Location	Antenna Model	Gain (dBi)	Meas. Distance (cm)	E/H Field	Calibration Factor	Average over Body (mW/cm ²)	Initial Power (W)	Pwr. Density Calc. (mW/cm ²)	Pwr. Density Max Calc. (mW/cm ²)
Roof (cnt)	HAF4016A	2.15	60	E	0.78	0.081	36.0	0.041	0.04
Measurement Grid									
Test Position	Height (cm)	% of Control Limit		Test Position	Height (cm)	% of Control Limit		IEEE Controlled Limit	IEEE Uncontrolled Limit
1	20	0.6%		6	120	2.5%		2.58	0.52
2	40	0.7%		7	140	3.4%			
3	60	0.7%		8	160	6.0%			
4	80	0.8%		9	180	7.2%			
5	100	1.5%		10	200	8.1%			

7/800MHz Mobile M20URS9PW1AN

P-Position 1

Table 4

Internal Vehicle MPE Assessment @ 773.0125 MHz										
Antenna Location	Antenna	Gain (dBi)	Meas. Distance (cm)	E/H Field	Calibration Factor	Average over Head, Chest, Lower Trunk Back/Front seats (mW/cm ²)		Initial Power (W)	Pwr. Density Calc. (mW/cm ²)	Pwr. Density Max Calc. (mW/cm ²)
						Back	Front			
Roof (cnt)	HAF4016A	2.15	Highest Reading	E	0.78	0.073	0.036	36.0	0.037	0.04
Measurement Grid										
Test Position		% of Control Limit Head		% of Control Limit Chest		% of Control Limit Lower Trunk		IEEE Controlled Limit:		2.58
Back Seat		3.0%		3.6%		1.9%		IEEE Uncontrolled Limit:		0.52
Front Seat		1.5%		1.7%		1.0%		RF Po (*Max):		36.0

BS-Position 1

Table 5

External Vehicle MPE Assessment @ 775.9125 MHz										
Antenna Location	Antenna Model	Gain (dBi)	Meas. Distance (cm)	E/H Field	Calibration Factor	Average over Body (mW/cm ²)	Initial Power (W)	Pwr. Density Calc. (mW/cm ²)	Pwr. Density Max Calc. (mW/cm ²)	
										Roof (cnt)
Measurement Grid										
Test Position	Height (cm)	% of Control Limit		Test Position	Height (cm)	% of Control Limit		IEEE Controlled Limit	IEEE Uncontrolled Limit	
1	20	1.1%		6	120	3.0%		2.59	0.52	
2	40	0.9%		7	140	3.9%				
3	60	1.2%		8	160	5.3%				
4	80	1.3%		9	180	7.2%				
5	100	1.9%		10	200	6.5%				
								RF Po (*Max):		36.0

P-Position 1

Table 6

Internal Vehicle MPE Assessment @ 775.9125 MHz										
Antenna Location	Antenna	Gain (dBi)	Meas. Distance (cm)	E/H Field	Calibration Factor	Average over Head, Chest, Lower Trunk Back/Front seats (mW/cm ²)		Initial Power (W)	Pwr. Density Calc. (mW/cm ²)	Pwr. Density Max Calc. (mW/cm ²)
						Back	Front			
Roof (cnt)	HAF4016A	2.15	Highest Reading	E	0.77	0.063	0.030	36.1	0.031	0.03
Measurement Grid										
Test Position		% of Control Limit Head		% of Control Limit Chest		% of Control Limit Lower Trunk		IEEE Controlled Limit:		2.59
Back Seat		2.3%		3.0%		2.0%		IEEE Uncontrolled Limit:		0.52
Front Seat		1.5%		1.0%		1.0%		RF Po (*Max):		36.0

7/800MHz Mobile M20URS9PW1AN

BS-Position 1

Table 7

External Vehicle MPE Assessment @ 794.0875 MHz									
Antenna Location	Antenna Model	Gain (dBi)	Meas. Distance (cm)	E/H Field	Calibration Factor	Average over Body (mW/cm ²)	Initial Power (W)	Pwr. Density Calc. (mW/cm ²)	Pwr. Density Max Calc. (mW/cm ²)
Roof (cnt)	HAF4016A	2.15	60	E	0.76	0.078	37.0	0.039	0.04
Measurement Grid									
Test Position	Height (cm)	% of Control Limit		Test Position	Height (cm)	% of Control Limit		IEEE Controlled Limit	IEEE Uncontrolled Limit
1	20	1.2%		6	120	3.1%		2.65	0.53
2	40	1.1%		7	140	3.4%			
3	60	1.1%		8	160	4.8%			
4	80	1.5%		9	180	5.7%			
5	100	2.2%		10	200	5.4%			
								RF Po (*Max)	
								36.0	

P-Position 1

Table 8

Internal Vehicle MPE Assessment @ 794.0875 MHz										
Antenna Location	Antenna Model	Gain (dBi)	Meas. Distance (cm)	E/H Field	Calibration Factor	Average over Head, Chest, Lower Trunk Back/Front seats (mW/cm ²)		Initial Power (W)	Pwr. Density Calc. (mW/cm ²)	Pwr. Density Max Calc. (mW/cm ²)
						Back	Front			
Roof (cnt)	HAF4016A	2.15	Highest Reading	E	0.76	0.067	0.032	37.0	0.034	0.03
Measurement Grid										
Test Position		% of Control Limit Head		% of Control Limit Chest		% of Control Limit Lower Trunk		IEEE Controlled Limit:		2.65
Back Seat		1.5%		4.2%		1.9%		IEEE Uncontrolled Limit:		0.53
Front Seat		1.3%		1.3%		1.0%		RF Po (*Max):		36.0

BS-Position 1

Table 9

External Vehicle MPE Assessment @ 809.0125 MHz									
Antenna Location	Antenna Model	Gain (dBi)	Meas. Distance (cm)	E/H Field	Calibration Factor	Average over Body (mW/cm ²)	Initial Power (W)	Pwr. Density Calc. (mW/cm ²)	Pwr. Density Max Calc. (mW/cm ²)
Roof (cnt)	HAF4016A	2.15	60	E	0.75	0.099	41.3	0.050	0.05
Measurement Grid									
Test Position	Height (cm)	% of Control Limit		Test Position	Height (cm)	% of Control Limit		IEEE Controlled Limit	IEEE Uncontrolled Limit
1	20	1.3%		6	120	3.4%		2.70	0.54
2	40	0.9%		7	140	5.5%			
3	60	1.1%		8	160	7.4%			
4	80	1.3%		9	180	7.1%			
5	100	2.1%		10	200	6.7%			
								RF Po (*Max)	
								42.0	

7/800MHz Mobile M20URS9PW1AN

P-Position 1

Table 10

Internal Vehicle MPE Assessment @ 809.0125 MHz										
Antenna Location	Antenna	Gain (dBi)	Meas. Distance (cm)	E/H Field	Calibration Factor	Average over Head, Chest, Lower Trunk Back/Front seats (mW/cm ²)		Initial Power (W)	Pwr. Density Calc. (mW/cm ²)	Pwr. Density Max Calc. (mW/cm ²)
						Back	Front			
Roof (cnt)	HAF4016A	2.15	Highest Reading	E	0.75	0.068	0.040	41.3	0.034	0.03
Measurement Grid										
Test Position		% of Control Limit Head		% of Control Limit Chest		% of Control Limit Lower Trunk		IEEE Controlled Limit:		2.70
Back Seat		2.7%		3.6%		1.3%		IEEE Uncontrolled Limit:		0.54
Front Seat		1.5%		1.5%		1.4%		RF Po (*Max):		42.0

BS-Position 1

Table 11

External Vehicle MPE Assessment @ 823.9875 MHz										
Antenna Location	Antenna Model	Gain (dBi)	Meas. Distance (cm)	E/H Field	Calibration Factor	Average over Body (mW/cm ²)	Initial Power (W)	Pwr. Density Calc. (mW/cm ²)	Pwr. Density Max Calc. (mW/cm ²)	
Roof (cnt)	HAF4016A	2.15	60	E	0.74	0.083	41.6	0.041	0.04	
Measurement Grid										
Test Position	Height (cm)	% of Control Limit		Test Position	Height (cm)	% of Control Limit		IEEE Controlled Limit	IEEE Uncontrolled Limit	
1	20	1.4%		6	120	2.3%		2.75	0.55	
2	40	0.6%		7	140	4.4%				
3	60	1.1%		8	160	5.4%				
4	80	1.7%		9	180	5.5%				
5	100	1.8%		10	200	6.0%				
								RF Po (*Max)		42.0

P-Position 1

Table 12

Internal Vehicle MPE Assessment @ 823.9875 MHz										
Antenna Location	Antenna	Gain (dBi)	Meas. Distance (cm)	E/H Field	Calibration Factor	Average over Head, Chest, Lower Trunk Back/Front seats (mW/cm ²)		Initial Power (W)	Pwr. Density Calc. (mW/cm ²)	Pwr. Density Max Calc. (mW/cm ²)
						Back	Front			
Roof (cnt)	HAF4016A	2.15	Highest Reading	E	0.74	0.049	0.051	41.6	0.026	0.03
Measurement Grid										
Test Position		% of Control Limit Head		% of Control Limit Chest		% of Control Limit Lower Trunk		IEEE Controlled Limit:		2.75
Back Seat		1.9%		2.2%		1.3%		IEEE Uncontrolled Limit:		0.55
Front Seat		1.9%		1.7%		2.0%		RF Po (*Max):		42.0

7/800MHz Mobile M20URS9PW1AN

BS-Position 1

Table 13

External Vehicle MPE Assessment @ 851.0125 MHz									
Antenna Location	Antenna Model	Gain (dBi)	Meas. Distance (cm)	E/H Field	Calibration Factor	Average over Body (mW/cm ²)	Initial Power (W)	Pwr. Density Calc. (mW/cm ²)	Pwr. Density Max Calc. (mW/cm ²)
Roof (cnt)	HAF4016A	2.15	60	E	0.73	0.074	41.9	0.037	0.04
Measurement Grid									
Test Position	Height (cm)	% of Control Limit		Test Position	Height (cm)	% of Control Limit		IEEE Controlled Limit	IEEE Uncontrolled Limit
1	20	0.6%		6	120	2.6%		2.84	0.57
2	40	0.8%		7	140	3.4%			
3	60	1.1%		8	160	4.4%			
4	80	1.3%		9	180	5.0%			
5	100	1.9%		10	200	4.9%			
								RF Po (*Max)	42.0

P-Position 1

Table 14

Internal Vehicle MPE Assessment @ 851.0125 MHz										
Antenna Location	Antenna Model	Gain (dBi)	Meas. Distance (cm)	E/H Field	Calibration Factor	Average over Head, Chest, Lower Trunk Back/Front seats (mW/cm ²)		Initial Power (W)	Pwr. Density Calc. (mW/cm ²)	Pwr. Density Max Calc. (mW/cm ²)
						Back	Front			
Roof (cnt)	HAF4016A	2.15	Highest Reading	E	0.73	0.045	0.026	41.9	0.023	0.02
Measurement Grid										
Test Position		% of Control Limit Head		% of Control Limit Chest		% of Control Limit Lower Trunk		IEEE Controlled Limit:		2.84
Back Seat		1.0%		1.2%		2.6%		IEEE Uncontrolled Limit:		0.57
Front Seat		0.8%		1.0%		1.0%		RF Po (*Max):		42.0

BS-Position 1

Table 15

External Vehicle MPE Assessment @ 859.0125 MHz									
Antenna Location	Antenna Model	Gain (dBi)	Meas. Distance (cm)	E/H Field	Calibration Factor	Average over Body (mW/cm ²)	Initial Power (W)	Pwr. Density Calc. (mW/cm ²)	Pwr. Density Max Calc. (mW/cm ²)
Roof (cnt)	HAF4016A	2.15	60	E	0.72	0.069	41.7	0.035	0.03
Measurement Grid									
Test Position	Height (cm)	% of Control Limit		Test Position	Height (cm)	% of Control Limit		IEEE Controlled Limit	IEEE Uncontrolled Limit
1	20	0.7%		6	120	2.2%		2.86	0.57
2	40	0.5%		7	140	2.8%			
3	60	1.2%		8	160	4.5%			
4	80	1.2%		9	180	4.8%			
5	100	1.2%		10	200	5.0%			
								RF Po (*Max)	42.0

7/800MHz Mobile M20URS9PW1AN

P-Position 1

Table 16

Internal Vehicle MPE Assessment @ 859.0125 MHz										
Antenna Location	Antenna	Gain (dBi)	Meas. Distance (cm)	E/H Field	Calibration Factor	Average over Head, Chest, Lower Trunk Back/Front seats (mW/cm ²)		Initial Power (W)	Pwr. Density Calc. (mW/cm ²)	Pwr. Density Max Calc. (mW/cm ²)
						Back	Front			
Roof (cnt)	HAF4016A	2.15	Highest Reading	E	0.72	0.047	0.057	41.7	0.029	0.03
Measurement Grid										
Test Position		% of Control Limit Head	% of Control Limit Chest	% of Control Limit Lower Trunk		IEEE Controlled Limit:			2.86	
Back Seat		1.5%	1.5%	1.9%		IEEE Uncontrolled Limit:			0.57	
Front Seat		2.0%	2.0%	2.0%		RF Po (*Max):			42.0	

BS-Position 1

Table 17

External Vehicle MPE Assessment @ 868.9875 MHz										
Antenna Location	Antenna Model	Gain (dBi)	Meas. Distance (cm)	E/H Field	Calibration Factor	Average over Body (mW/cm ²)	Initial Power (W)	Pwr. Density Calc. (mW/cm ²)	Pwr. Density Max Calc. (mW/cm ²)	
Roof (cnt)	HAF4016A	2.15	60	E	0.71	0.077	41.9	0.039	0.04	
Measurement Grid										
Test Position	Height (cm)	% of Control Limit		Test Position	Height (cm)	% of Control Limit		IEEE Controlled Limit	IEEE Uncontrolled Limit	
1	20	0.4%		6	120	1.6%		2.90	0.58	
2	40	0.5%		7	140	3.6%				
3	60	1.0%		8	160	5.0%				
4	80	1.0%		9	180	6.0%				
5	100	1.6%		10	200	5.9%				
								RF Po (*Max)		42.0

P-Position 1

Table 18

Internal Vehicle MPE Assessment @ 868.9875 MHz										
Antenna Location	Antenna	Gain (dBi)	Meas. Distance (cm)	E/H Field	Calibration Factor	Average over Head, Chest, Lower Trunk Back/Front seats (mW/cm ²)		Initial Power (W)	Pwr. Density Calc. (mW/cm ²)	Pwr. Density Max Calc. (mW/cm ²)
						Back	Front			
Roof (cnt)	HAF4016A	2.15	Highest Reading	E	0.71	0.020	0.014	41.9	0.010	0.01
Measurement Grid										
Test Position		% of Control Limit Head	% of Control Limit Chest	% of Control Limit Lower Trunk		IEEE Controlled Limit:			2.90	
Back Seat		0.9%	0.6%	0.6%		IEEE Uncontrolled Limit:			0.58	
Front Seat		0.4%	0.5%	0.5%		RF Po (*Max):			42.0	

7/800MHz Mobile M20URS9PW1AN

BS-Position 1

Table 19

External Vehicle MPE Assessment @ 764.0875 MHz									
Antenna Location	Antenna Model	Gain (dBi)	Meas. Distance (cm)	E/H Field	Calibration Factor	Average over Body (mW/cm ²)	Initial Power (W)	Pwr. Density Calc. (mW/cm ²)	Pwr. Density Max Calc. (mW/cm ²)
Roof (cnt)	HAF4014A	5.15	60	E	0.78	0.092	36.0	0.046	0.05
Measurement Grid									
Test Position	Height (cm)	% of Control Limit		Test Position	Height (cm)	% of Control Limit		IEEE Controlled Limit	IEEE Uncontrolled Limit
1	20	1.4%		6	120	4.8%		2.55	0.51
2	40	1.1%		7	140	5.5%			
3	60	1.5%		8	160	6.8%			
4	80	1.4%		9	180	6.5%			
5	100	1.9%		10	200	5.1%			

P-Position 1

Table 20

Internal Vehicle MPE Assessment @ 764.0875 MHz										
Antenna Location	Antenna	Gain (dBi)	Meas. Distance (cm)	E/H Field	Calibration Factor	Average over Head, Chest, Lower Trunk Back/Front seats (mW/cm ²)		Initial Power (W)	Pwr. Density Calc. (mW/cm ²)	Pwr. Density Max Calc. (mW/cm ²)
						Back	Front			
Roof (cnt)	HAF4014A	5.15	Highest Reading	E	0.78	0.081	0.036	36.0	0.040	0.04
Measurement Grid										
Test Position		% of Control Limit Head		% of Control Limit Chest		% of Control Limit Lower Trunk		IEEE Controlled Limit:		2.55
Back Seat		3.2%		4.0%		2.3%		IEEE Uncontrolled Limit:		0.51
Front Seat		2.0%		0.9%		1.3%		RF Po (*Max):		36.0

BS-Position 1

Table 21

External Vehicle MPE Assessment @ 773.0125 MHz									
Antenna Location	Antenna Model	Gain (dBi)	Meas. Distance (cm)	E/H Field	Calibration Factor	Average over Body (mW/cm ²)	Initial Power (W)	Pwr. Density Calc. (mW/cm ²)	Pwr. Density Max Calc. (mW/cm ²)
Roof (cnt)	HAF4014A	5.15	60	E	0.78	0.119	36.0	0.059	0.06
Measurement Grid									
Test Position	Height (cm)	% of Control Limit		Test Position	Height (cm)	% of Control Limit		IEEE Controlled Limit	IEEE Uncontrolled Limit
1	20	1.4%		6	120	6.6%		2.58	0.52
2	40	0.9%		7	140	6.8%			
3	60	0.9%		8	160	10.1%			
4	80	1.4%		9	180	9.1%			
5	100	3.3%		10	200	5.5%			

7/800MHz Mobile M20URS9PW1AN

P-Position 1

Table 22

Internal Vehicle MPE Assessment @ 773.0125 MHz										
Antenna Location	Antenna	Gain (dBi)	Meas. Distance (cm)	E/H Field	Calibration Factor	Average over Head, Chest, Lower Trunk Back/Front seats (mW/cm ²)		Initial Power (W)	Pwr. Density Calc. (mW/cm ²)	Pwr. Density Max Calc. (mW/cm ²)
						Back	Front			
Roof (cnt)	HAF4014A	5.15	Highest Reading	E	0.78	0.094	0.033	36.0	0.047	0.05
Measurement Grid										
Test Position		% of Control Limit Head	% of Control Limit Chest	% of Control Limit Lower Trunk		IEEE Controlled Limit:			2.58	
Back Seat		3.7%	4.7%	2.5%		IEEE Uncontrolled Limit:			0.52	
Front Seat		1.2%	1.6%	1.1%		RF Po (*Max):			36.0	

BS-Position 1

Table 23

External Vehicle MPE Assessment @ 775.9125 MHz									
Antenna Location	Antenna Model	Gain (dBi)	Meas. Distance (cm)	E/H Field	Calibration Factor	Average over Body (mW/cm ²)	Initial Power (W)	Pwr. Density Calc. (mW/cm ²)	Pwr. Density Max Calc. (mW/cm ²)
Roof (cnt)	HAF4014A	5.15	60	E	0.77	0.106	36.1	0.053	0.05
Measurement Grid									
Test Position	Height (cm)	% of Control Limit		Test Position	Height (cm)	% of Control Limit		IEEE Controlled Limit	IEEE Uncontrolled Limit
1	20	0.8%		6	120	6.0%		RF Po (*Max):	0.52
2	40	1.0%		7	140	6.4%			
3	60	1.4%		8	160	8.5%			
4	80	1.7%		9	180	7.2%			
5	100	3.3%		10	200	4.8%			36.0

P-Position 1

Table 24

Internal Vehicle MPE Assessment @ 775.9125 MHz										
Antenna Location	Antenna	Gain (dBi)	Meas. Distance (cm)	E/H Field	Calibration Factor	Average over Head, Chest, Lower Trunk Back/Front seats (mW/cm ²)		Initial Power (W)	Pwr. Density Calc. (mW/cm ²)	Pwr. Density Max Calc. (mW/cm ²)
						Back	Front			
Roof (cnt)	HAF4014A	5.15	Highest Reading	E	0.77	0.081	0.046	36.1	0.041	0.04
Measurement Grid										
Test Position		% of Control Limit Head	% of Control Limit Chest	% of Control Limit Lower Trunk		IEEE Controlled Limit:			2.59	
Back Seat		2.9%	4.3%	2.2%		IEEE Uncontrolled Limit:			0.52	
Front Seat		1.6%	1.5%	2.2%		RF Po (*Max):			36.0	

7/800MHz Mobile M20URS9PW1AN

BS-Position 1

Table 25

External Vehicle MPE Assessment @ 794.0875 MHz									
Antenna Location	Antenna Model	Gain (dBi)	Meas. Distance (cm)	E/H Field	Calibration Factor	Average over Body (mW/cm ²)	Initial Power (W)	Pwr. Density Calc. (mW/cm ²)	Pwr. Density Max Calc. (mW/cm ²)
Roof (cnt)	HAF4014A	5.15	60	E	0.76	0.100	37.0	0.050	0.05
Measurement Grid									
Test Position	Height (cm)	% of Control Limit		Test Position	Height (cm)	% of Control Limit		IEEE Controlled Limit	IEEE Uncontrolled Limit
1	20	0.7%		6	120	3.6%		2.65	0.53
2	40	0.8%		7	140	7.7%			
3	60	0.9%		8	160	8.4%			
4	80	1.5%		9	180	6.3%			
5	100	2.8%		10	200	5.1%			
								RF Po (*Max)	
								36.0	

P-Position 1

Table 26

Internal Vehicle MPE Assessment @ 794.0875 MHz										
Antenna Location	Antenna Model	Gain (dBi)	Meas. Distance (cm)	E/H Field	Calibration Factor	Average over Head, Chest, Lower Trunk Back/Front seats (mW/cm ²)		Initial Power (W)	Pwr. Density Calc. (mW/cm ²)	Pwr. Density Max Calc. (mW/cm ²)
						Back	Front			
Roof (cnt)	HAF4014A	5.15	Highest Reading	E	0.76	0.070	0.035	37.0	0.035	0.03
Measurement Grid										
Test Position		% of Control Limit Head		% of Control Limit Chest		% of Control Limit Lower Trunk		IEEE Controlled Limit:		2.65
Back Seat		2.4%		3.7%		1.8%		IEEE Uncontrolled Limit:		0.53
Front Seat		1.7%		1.3%		1.0%		RF Po (*Max):		36.0

BS-Position 1

Table 27

External Vehicle MPE Assessment @ 809.0125 MHz									
Antenna Location	Antenna Model	Gain (dBi)	Meas. Distance (cm)	E/H Field	Calibration Factor	Average over Body (mW/cm ²)	Initial Power (W)	Pwr. Density Calc. (mW/cm ²)	Pwr. Density Max Calc. (mW/cm ²)
Roof (cnt)	HAF4014A	5.15	60	E	0.75	0.124	41.3	0.062	0.06
Measurement Grid									
Test Position	Height (cm)	% of Control Limit		Test Position	Height (cm)	% of Control Limit		IEEE Controlled Limit	IEEE Uncontrolled Limit
1	20	0.7%		6	120	5.8%		2.70	0.54
2	40	1.0%		7	140	8.0%			
3	60	1.6%		8	160	10.9%			
4	80	1.6%		9	180	7.5%			
5	100	3.7%		10	200	5.3%			
								RF Po (*Max)	
								42.0	

7/800MHz Mobile M20URS9PW1AN

P-Position 1

Table 28

Internal Vehicle MPE Assessment @ 809.0125 MHz										
Antenna Location	Antenna	Gain (dBi)	Meas. Distance (cm)	E/H Field	Calibration Factor	Average over Head, Chest, Lower Trunk Back/Front seats (mW/cm ²)		Initial Power (W)	Pwr. Density Calc. (mW/cm ²)	Pwr. Density Max Calc. (mW/cm ²)
						Back	Front			
Roof (cnt)	HAF4014A	5.15	Highest Reading	E	0.75	0.072	0.076	41.3	0.038	0.04
Measurement Grid										
Test Position		% of Control Limit Head		% of Control Limit Chest		% of Control Limit Lower Trunk		IEEE Controlled Limit:		2.70
Back Seat		2.4%		4.0%		1.6%		IEEE Uncontrolled Limit:		0.54
Front Seat		2.6%		3.8%		2.0%		RF Po (*Max):		42.0

BS-Position 1

Table 29

External Vehicle MPE Assessment @ 823.9875 MHz										
Antenna Location	Antenna Model	Gain (dBi)	Meas. Distance (cm)	E/H Field	Calibration Factor	Average over Body (mW/cm ²)	Initial Power (W)	Pwr. Density Calc. (mW/cm ²)	Pwr. Density Max Calc. (mW/cm ²)	
Roof (cnt)	HAF4014A	5.15	60	E	0.74	0.092	41.6	0.046	0.05	
Measurement Grid										
Test Position	Height (cm)	% of Control Limit		Test Position	Height (cm)	% of Control Limit		IEEE Controlled Limit	IEEE Uncontrolled Limit	
1	20	0.8%		6	120	3.8%		2.75	0.55	
2	40	0.8%		7	140	5.9%				
3	60	1.1%		8	160	7.6%				
4	80	1.1%		9	180	5.0%				
5	100	2.6%		10	200	4.7%				
								RF Po (*Max)		42.0

P-Position 1

Table 30

Internal Vehicle MPE Assessment @ 823.9875 MHz										
Antenna Location	Antenna	Gain (dBi)	Meas. Distance (cm)	E/H Field	Calibration Factor	Average over Head, Chest, Lower Trunk Back/Front seats (mW/cm ²)		Initial Power (W)	Pwr. Density Calc. (mW/cm ²)	Pwr. Density Max Calc. (mW/cm ²)
						Back	Front			
Roof (cnt)	HAF4014A	5.15	Highest Reading	E	0.74	0.061	0.044	41.6	0.031	0.03
Measurement Grid										
Test Position		% of Control Limit Head		% of Control Limit Chest		% of Control Limit Lower Trunk		IEEE Controlled Limit:		2.75
Back Seat		2.0%		3.5%		1.2%		IEEE Uncontrolled Limit:		0.55
Front Seat		1.8%		1.2%		1.8%		RF Po (*Max):		42.0

7/800MHz Mobile M20URS9PW1AN

BS-Position 1

Table 31

External Vehicle MPE Assessment @ 851.0125 MHz									
Antenna Location	Antenna Model	Gain (dBi)	Meas. Distance (cm)	E/H Field	Calibration Factor	Average over Body (mW/cm ²)	Initial Power (W)	Pwr. Density Calc. (mW/cm ²)	Pwr. Density Max Calc. (mW/cm ²)
Roof (cnt)	HAF4014A	5.15	60	E	0.73	0.096	41.9	0.048	0.05
Measurement Grid									
Test Position	Height (cm)	% of Control Limit		Test Position	Height (cm)	% of Control Limit		IEEE Controlled Limit	IEEE Uncontrolled Limit
1	20	1.1%		6	120	2.7%		2.84	0.57
2	40	0.8%		7	140	4.7%			
3	60	1.3%		8	160	6.9%			
4	80	1.5%		9	180	7.2%			
5	100	2.2%		10	200	5.3%			
								RF Po (*Max)	42.0

P-Position 1

Table 32

Internal Vehicle MPE Assessment @ 851.0125 MHz										
Antenna Location	Antenna Model	Gain (dBi)	Meas. Distance (cm)	E/H Field	Calibration Factor	Average over Head, Chest, Lower Trunk Back/Front seats (mW/cm ²)		Initial Power (W)	Pwr. Density Calc. (mW/cm ²)	Pwr. Density Max Calc. (mW/cm ²)
						Back	Front			
Roof (cnt)	HAF4014A	5.15	Highest Reading	E	0.73	0.069	0.038	41.9	0.035	0.03
Measurement Grid										
Test Position		% of Control Limit Head		% of Control Limit Chest		% of Control Limit Lower Trunk		IEEE Controlled Limit:		2.84
Back Seat		1.4%		1.7%		4.2%		IEEE Uncontrolled Limit:		0.57
Front Seat		0.8%		1.4%		1.8%		RF Po (*Max):		42.0

BS-Position 1

Table 33

External Vehicle MPE Assessment @ 859.0125 MHz									
Antenna Location	Antenna Model	Gain (dBi)	Meas. Distance (cm)	E/H Field	Calibration Factor	Average over Body (mW/cm ²)	Initial Power (W)	Pwr. Density Calc. (mW/cm ²)	Pwr. Density Max Calc. (mW/cm ²)
Roof (cnt)	HAF4014A	5.15	60	E	0.72	0.102	41.7	0.051	0.05
Measurement Grid									
Test Position	Height (cm)	% of Control Limit		Test Position	Height (cm)	% of Control Limit		IEEE Controlled Limit	IEEE Uncontrolled Limit
1	20	1.0%		6	120	3.0%		2.86	0.57
2	40	1.0%		7	140	5.2%			
3	60	1.0%		8	160	7.6%			
4	80	1.3%		9	180	7.5%			
5	100	2.3%		10	200	5.8%			
								RF Po (*Max)	42.0

7/800MHz Mobile M20URS9PW1AN

P-Position 1

Table 34

Internal Vehicle MPE Assessment @ 859.0125 MHz										
Antenna Location	Antenna	Gain (dBi)	Meas. Distance (cm)	E/H Field	Calibration Factor	Average over Head, Chest, Lower Trunk Back/Front seats (mW/cm ²)		Initial Power (W)	Pwr. Density Calc. (mW/cm ²)	Pwr. Density Max Calc. (mW/cm ²)
						Back	Front			
Roof (cnt)	HAF4014A	5.15	Highest Reading	E	0.72	0.089	0.061	41.7	0.044	0.04
Measurement Grid										
Test Position		% of Control Limit Head	% of Control Limit Chest	% of Control Limit Lower Trunk		IEEE Controlled Limit:			2.86	
Back Seat		2.2%	2.6%	4.5%		IEEE Uncontrolled Limit:			0.57	
Front Seat		1.7%	2.4%	2.3%		RF Po (*Max):			42.0	

BS-Position 1

Table 35

External Vehicle MPE Assessment @ 868.9875 MHz										
Antenna Location	Antenna Model	Gain (dBi)	Meas. Distance (cm)	E/H Field	Calibration Factor	Average over Body (mW/cm ²)	Initial Power (W)	Pwr. Density Calc. (mW/cm ²)	Pwr. Density Max Calc. (mW/cm ²)	
Roof (cnt)	HAF4014A	5.15	60	E	0.71	0.095	41.9	0.047	0.05	
Measurement Grid										
Test Position	Height (cm)	% of Control Limit		Test Position	Height (cm)	% of Control Limit		IEEE Controlled Limit	IEEE Uncontrolled Limit	
1	20	1.0%		6	120	3.0%		2.90	0.58	
2	40	0.5%		7	140	5.4%				
3	60	0.9%		8	160	7.2%				
4	80	1.4%		9	180	6.3%				
5	100	1.8%		10	200	5.2%				
								RF Po (*Max)		42.0

P-Position 1

Table 36

Internal Vehicle MPE Assessment @ 868.9875 MHz										
Antenna Location	Antenna	Gain (dBi)	Meas. Distance (cm)	E/H Field	Calibration Factor	Average over Head, Chest, Lower Trunk Back/Front seats (mW/cm ²)		Initial Power (W)	Pwr. Density Calc. (mW/cm ²)	Pwr. Density Max Calc. (mW/cm ²)
						Back	Front			
Roof (cnt)	HAF4014A	5.15	Highest Reading	E	0.71	0.042	0.040	41.9	0.021	0.02
Measurement Grid										
Test Position		% of Control Limit Head	% of Control Limit Chest	% of Control Limit Lower Trunk		IEEE Controlled Limit:			2.90	
Back Seat		1.8%	1.3%	1.3%		IEEE Uncontrolled Limit:			0.58	
Front Seat		0.6%	1.6%	1.9%		RF Po (*Max):			42.0	

7/800MHz Mobile M20URS9PW1AN

BS-Position 1

Table 37

External Vehicle MPE Assessment @ 764.0875 MHz									
Antenna Location	Antenna Model	Gain (dBi)	Meas. Distance (cm)	E/H Field	Calibration Factor	Average over Body (mW/cm ²)	Initial Power (W)	Pwr. Density Calc. (mW/cm ²)	Pwr. Density Max Calc. (mW/cm ²)
Roof (cnt)	HAF4013A	5.15	60	E	0.78	0.088	36.0	0.044	0.04
Measurement Grid									
Test Position	Height (cm)	% of Control Limit		Test Position	Height (cm)	% of Control Limit		IEEE Controlled Limit	IEEE Uncontrolled Limit
1	20	0.8%		6	120	3.2%		2.55	0.51
2	40	0.9%		7	140	4.6%			
3	60	1.1%		8	160	6.2%			
4	80	0.9%		9	180	8.4%			
5	100	1.2%		10	200	7.3%			

P-Position 1

Table 38

Internal Vehicle MPE Assessment @ 764.0875 MHz										
Antenna Location	Antenna	Gain (dBi)	Meas. Distance (cm)	E/H Field	Calibration Factor	Average over Head, Chest, Lower Trunk Back/Front seats (mW/cm ²)		Initial Power (W)	Pwr. Density Calc. (mW/cm ²)	Pwr. Density Max Calc. (mW/cm ²)
						Back	Front			
Roof (cnt)	HAF4013A	5.15	Highest Reading	E	0.78	0.063	0.022	36.0	0.031	0.03
Measurement Grid										
Test Position		% of Control Limit Head		% of Control Limit Chest		% of Control Limit Lower Trunk		IEEE Controlled Limit:		2.55
Back Seat		2.5%		3.3%		1.6%		IEEE Uncontrolled Limit:		0.51
Front Seat		1.3%		0.5%		0.8%		RF Po (*Max):		36.0

BS-Position 1

Table 39

External Vehicle MPE Assessment @ 773.0125 MHz									
Antenna Location	Antenna Model	Gain (dBi)	Meas. Distance (cm)	E/H Field	Calibration Factor	Average over Body (mW/cm ²)	Initial Power (W)	Pwr. Density Calc. (mW/cm ²)	Pwr. Density Max Calc. (mW/cm ²)
Roof (cnt)	HAF4013A	5.15	60	E	0.78	0.097	36.0	0.048	0.05
Measurement Grid									
Test Position	Height (cm)	% of Control Limit		Test Position	Height (cm)	% of Control Limit		IEEE Controlled Limit	IEEE Uncontrolled Limit
1	20	0.6%		6	120	4.3%		2.58	0.52
2	40	0.9%		7	140	4.7%			
3	60	1.0%		8	160	6.5%			
4	80	0.9%		9	180	8.8%			
5	100	2.0%		10	200	7.8%			

7/800MHz Mobile M20URS9PW1AN

P-Position 1

Table 40

Internal Vehicle MPE Assessment @ 773.0125 MHz										
Antenna Location	Antenna	Gain (dBi)	Meas. Distance (cm)	E/H Field	Calibration Factor	Average over Head, Chest, Lower Trunk Back/Front seats (mW/cm ²)		Initial Power (W)	Pwr. Density Calc. (mW/cm ²)	Pwr. Density Max Calc. (mW/cm ²)
						Back	Front			
Roof (cnt)	HAF4013A	5.15	Highest Reading	E	0.78	0.082	0.025	36.0	0.041	0.04
Measurement Grid										
Test Position		% of Control Limit Head	% of Control Limit Chest	% of Control Limit Lower Trunk		IEEE Controlled Limit:			2.58	
Back Seat		3.9%	4.2%	1.5%		IEEE Uncontrolled Limit:			0.52	
Front Seat		1.4%	0.7%	0.8%		RF Po (*Max):			36.0	

BS-Position 1

Table 41

External Vehicle MPE Assessment @ 775.9125 MHz										
Antenna Location	Antenna Model	Gain (dBi)	Meas. Distance (cm)	E/H Field	Calibration Factor	Average over Body (mW/cm ²)	Initial Power (W)	Pwr. Density Calc. (mW/cm ²)	Pwr. Density Max Calc. (mW/cm ²)	
Roof (cnt)	HAF4013A	5.15	60	E	0.77	0.095	36.1	0.047	0.05	
Measurement Grid										
Test Position	Height (cm)	% of Control Limit		Test Position	Height (cm)	% of Control Limit		IEEE Controlled Limit	IEEE Uncontrolled Limit	
1	20	0.7%		6	120	3.4%		2.59	0.52	
2	40	0.9%		7	140	4.4%				
3	60	0.9%		8	160	6.5%				
4	80	1.0%		9	180	9.1%				
5	100	1.8%		10	200	7.9%				
								RF Po (*Max)		36.0

P-Position 1

Table 42

Internal Vehicle MPE Assessment @ 775.9125 MHz										
Antenna Location	Antenna	Gain (dBi)	Meas. Distance (cm)	E/H Field	Calibration Factor	Average over Head, Chest, Lower Trunk Back/Front seats (mW/cm ²)		Initial Power (W)	Pwr. Density Calc. (mW/cm ²)	Pwr. Density Max Calc. (mW/cm ²)
						Back	Front			
Roof (cnt)	HAF4013A	5.15	Highest Reading	E	0.77	0.085	0.028	36.1	0.043	0.04
Measurement Grid										
Test Position		% of Control Limit Head	% of Control Limit Chest	% of Control Limit Lower Trunk		IEEE Controlled Limit:			2.59	
Back Seat		2.7%	4.9%	2.3%		IEEE Uncontrolled Limit:			0.52	
Front Seat		1.3%	0.9%	1.0%		RF Po (*Max):			36.0	

7/800MHz Mobile M20URS9PW1AN

BS-Position 1

Table 43

External Vehicle MPE Assessment @ 794.0875 MHz										
Antenna Location	Antenna Model	Gain (dBi)	Meas. Distance (cm)	E/H Field	Calibration Factor	Average over Body (mW/cm ²)	Initial Power (W)	Pwr. Density Calc. (mW/cm ²)	Pwr. Density Max Calc. (mW/cm ²)	
Roof (cnt)	HAF4013A	5.15	60	E	0.76	0.107	37.0	0.053	0.05	
Measurement Grid										
Test Position	Height (cm)	% of Control Limit		Test Position	Height (cm)	% of Control Limit		IEEE Controlled Limit	IEEE Uncontrolled Limit	
1	20	1.3%		6	120	3.5%		2.65	0.53	
2	40	1.2%		7	140	4.8%				
3	60	1.3%		8	160	6.8%				
4	80	1.6%		9	180	8.9%				
5	100	2.5%		10	200	8.4%				
								RF Po (*Max)		36.0

P-Position 1

Table 44

Internal Vehicle MPE Assessment @ 794.0875 MHz										
Antenna Location	Antenna Model	Gain (dBi)	Meas. Distance (cm)	E/H Field	Calibration Factor	Average over Head, Chest, Lower Trunk Back/Front seats (mW/cm ²)		Initial Power (W)	Pwr. Density Calc. (mW/cm ²)	Pwr. Density Max Calc. (mW/cm ²)
						Back	Front			
Roof (cnt)	HAF4013A	5.15	Highest Reading	E	0.76	0.071	0.024	37.0	0.035	0.04
Measurement Grid										
Test Position		% of Control Limit Head		% of Control Limit Chest		% of Control Limit Lower Trunk		IEEE Controlled Limit:		2.65
Back Seat		3.0%		3.6%		1.4%		IEEE Uncontrolled Limit:		0.53
Front Seat		1.0%		0.7%		1.0%		RF Po (*Max):		36.0

BS-Position 1

Table 45

External Vehicle MPE Assessment @ 809.0125 MHz										
Antenna Location	Antenna Model	Gain (dBi)	Meas. Distance (cm)	E/H Field	Calibration Factor	Average over Body (mW/cm ²)	Initial Power (W)	Pwr. Density Calc. (mW/cm ²)	Pwr. Density Max Calc. (mW/cm ²)	
Roof (cnt)	HAF4013A	5.15	60	E	0.75	0.125	41.3	0.063	0.06	
Measurement Grid										
Test Position	Height (cm)	% of Control Limit		Test Position	Height (cm)	% of Control Limit		IEEE Controlled Limit	IEEE Uncontrolled Limit	
1	20	1.2%		6	120	4.4%		2.70	0.54	
2	40	1.2%		7	140	6.3%				
3	60	1.3%		8	160	8.3%				
4	80	1.8%		9	180	10.0%				
5	100	2.7%		10	200	9.3%				
								RF Po (*Max)		42.0

7/800MHz Mobile M20URS9PW1AN

P-Position 1

Table 46

Internal Vehicle MPE Assessment @ 809.0125 MHz										
Antenna Location	Antenna	Gain (dBi)	Meas. Distance (cm)	E/H Field	Calibration Factor	Average over Head, Chest, Lower Trunk Back/Front seats (mW/cm ²)		Initial Power (W)	Pwr. Density Calc. (mW/cm ²)	Pwr. Density Max Calc. (mW/cm ²)
						Back	Front			
Roof (cnt)	HAF4013A	5.15	Highest Reading	E	0.75	0.061	0.045	41.3	0.031	0.03
Measurement Grid										
Test Position		% of Control Limit Head		% of Control Limit Chest		% of Control Limit Lower Trunk		IEEE Controlled Limit:		2.70
Back Seat		2.3%		3.3%		1.2%		IEEE Uncontrolled Limit:		0.54
Front Seat		1.8%		1.5%		1.7%		RF Po (*Max):		42.0

BS-Position 1

Table 47

External Vehicle MPE Assessment @ 823.9875 MHz										
Antenna Location	Antenna Model	Gain (dBi)	Meas. Distance (cm)	E/H Field	Calibration Factor	Average over Body (mW/cm ²)	Initial Power (W)	Pwr. Density Calc. (mW/cm ²)	Pwr. Density Max Calc. (mW/cm ²)	
Roof (cnt)	HAF4013A	5.15	60	E	0.74	0.121	41.6	0.061	0.06	
Measurement Grid										
Test Position	Height (cm)	% of Control Limit		Test Position	Height (cm)	% of Control Limit		IEEE Controlled Limit	IEEE Uncontrolled Limit	
1	20	1.1%		6	120	3.9%		2.75	0.55	
2	40	1.1%		7	140	5.3%				
3	60	1.2%		8	160	6.8%				
4	80	2.0%		9	180	8.5%				
5	100	2.7%		10	200	8.3%				
								RF Po (*Max)		42.0

P-Position 1

Table 48

Internal Vehicle MPE Assessment @ 823.9875 MHz										
Antenna Location	Antenna	Gain (dBi)	Meas. Distance (cm)	E/H Field	Calibration Factor	Average over Head, Chest, Lower Trunk Back/Front seats (mW/cm ²)		Initial Power (W)	Pwr. Density Calc. (mW/cm ²)	Pwr. Density Max Calc. (mW/cm ²)
						Back	Front			
Roof (cnt)	HAF4013A	5.15	Highest Reading	E	0.74	0.071	0.040	41.6	0.036	0.04
Measurement Grid										
Test Position		% of Control Limit Head		% of Control Limit Chest		% of Control Limit Lower Trunk		IEEE Controlled Limit:		2.75
Back Seat		3.1%		2.8%		1.9%		IEEE Uncontrolled Limit:		0.55
Front Seat		1.5%		1.5%		1.4%		RF Po (*Max):		42.0

7/800MHz Mobile M20URS9PW1AN

BS-Position 1

Table 49

External Vehicle MPE Assessment @ 851.0125 MHz									
Antenna Location	Antenna Model	Gain (dBi)	Meas. Distance (cm)	E/H Field	Calibration Factor	Average over Body (mW/cm ²)	Initial Power (W)	Pwr. Density Calc. (mW/cm ²)	Pwr. Density Max Calc. (mW/cm ²)
Roof (cnt)	HAF4013A	5.15	60	E	0.73	0.107	41.9	0.054	0.05
Measurement Grid									
Test Position	Height (cm)	% of Control Limit		Test Position	Height (cm)	% of Control Limit		IEEE Controlled Limit	IEEE Uncontrolled Limit
1	20	1.0%		6	120	3.1%		2.84	0.57
2	40	1.0%		7	140	4.9%			
3	60	1.4%		8	160	7.3%			
4	80	1.9%		9	180	7.7%			
5	100	2.1%		10	200	7.4%			
								RF Po (*Max)	
								42.0	

P-Position 1

Table 50

Internal Vehicle MPE Assessment @ 851.0125 MHz										
Antenna Location	Antenna Model	Gain (dBi)	Meas. Distance (cm)	E/H Field	Calibration Factor	Average over Head, Chest, Lower Trunk Back/Front seats (mW/cm ²)		Initial Power (W)	Pwr. Density Calc. (mW/cm ²)	Pwr. Density Max Calc. (mW/cm ²)
						Back	Front			
Roof (cnt)	HAF4013A	5.15	Highest Reading	E	0.73	0.045	0.017	41.9	0.023	0.02
Measurement Grid										
Test Position		% of Control Limit Head		% of Control Limit Chest		% of Control Limit Lower Trunk		IEEE Controlled Limit:		2.84
Back Seat		0.7%		0.6%		3.5%		IEEE Uncontrolled Limit:		0.57
Front Seat		0.4%		0.7%		0.7%		RF Po (*Max):		42.0

BS-Position 1

Table 51

External Vehicle MPE Assessment @ 859.0125 MHz									
Antenna Location	Antenna Model	Gain (dBi)	Meas. Distance (cm)	E/H Field	Calibration Factor	Average over Body (mW/cm ²)	Initial Power (W)	Pwr. Density Calc. (mW/cm ²)	Pwr. Density Max Calc. (mW/cm ²)
Roof (cnt)	HAF4013A	5.15	60	E	0.72	0.109	41.7	0.055	0.05
Measurement Grid									
Test Position	Height (cm)	% of Control Limit		Test Position	Height (cm)	% of Control Limit		IEEE Controlled Limit	IEEE Uncontrolled Limit
1	20	1.0%		6	120	3.0%		2.86	0.57
2	40	1.1%		7	140	4.6%			
3	60	1.2%		8	160	7.3%			
4	80	2.0%		9	180	7.9%			
5	100	2.4%		10	200	7.6%			
								RF Po (*Max)	
								42.0	

7/800MHz Mobile M20URS9PW1AN

P-Position 1

Table 52

Internal Vehicle MPE Assessment @ 859.0125 MHz										
Antenna Location	Antenna	Gain (dBi)	Meas. Distance (cm)	E/H Field	Calibration Factor	Average over Head, Chest, Lower Trunk Back/Front seats (mW/cm ²)		Initial Power (W)	Pwr. Density Calc. (mW/cm ²)	Pwr. Density Max Calc. (mW/cm ²)
						Back	Front			
Roof (cnt)	HAF4013A	5.15	Highest Reading	E	0.72	0.030	0.022	41.7	0.015	0.01
Measurement Grid										
Test Position		% of Control Limit Head		% of Control Limit Chest		% of Control Limit Lower Trunk		IEEE Controlled Limit:		2.86
Back Seat		0.7%		0.9%		1.5%		IEEE Uncontrolled Limit:		0.57
Front Seat		0.6%		1.0%		0.7%		RF Po (*Max):		42.0

BS-Position 1

Table 53

External Vehicle MPE Assessment @ 868.9875 MHz										
Antenna Location	Antenna Model	Gain (dBi)	Meas. Distance (cm)	E/H Field	Calibration Factor	Average over Body (mW/cm ²)	Initial Power (W)	Pwr. Density Calc. (mW/cm ²)	Pwr. Density Max Calc. (mW/cm ²)	
Roof (cnt)	HAF4013A	5.15	60	E	0.71	0.113	41.9	0.056	0.06	
Measurement Grid										
Test Position	Height (cm)	% of Control Limit		Test Position	Height (cm)	% of Control Limit		IEEE Controlled Limit	IEEE Uncontrolled Limit	
1	20	1.0%		6	120	2.7%		2.90	0.58	
2	40	1.0%		7	140	5.4%				
3	60	1.5%		8	160	7.8%				
4	80	1.9%		9	180	8.0%				
5	100	2.1%		10	200	7.5%				
								RF Po (*Max)		42.0

P-Position 1

Table 54

Internal Vehicle MPE Assessment @ 868.9875 MHz										
Antenna Location	Antenna	Gain (dBi)	Meas. Distance (cm)	E/H Field	Calibration Factor	Average over Head, Chest, Lower Trunk Back/Front seats (mW/cm ²)		Initial Power (W)	Pwr. Density Calc. (mW/cm ²)	Pwr. Density Max Calc. (mW/cm ²)
						Back	Front			
Roof (cnt)	HAF4013A	5.15	Highest Reading	E	0.71	0.024	0.024	41.9	0.012	0.01
Measurement Grid										
Test Position		% of Control Limit Head		% of Control Limit Chest		% of Control Limit Lower Trunk		IEEE Controlled Limit:		2.90
Back Seat		1.0%		0.9%		0.6%		IEEE Uncontrolled Limit:		0.58
Front Seat		0.3%		1.2%		1.0%		RF Po (*Max):		42.0

7/800MHz Mobile M20URS9PW1AN

BS-Position 1

Table 55

External Vehicle MPE Assessment @ 764.0875 MHz									
Antenna Location	Antenna Model	Gain (dBi)	Meas. Distance (cm)	E/H Field	Calibration Factor	Average over Body (mW/cm ²)	Initial Power (W)	Pwr. Density Calc. (mW/cm ²)	Pwr. Density Max Calc. (mW/cm ²)
Roof (cnt)	HAF4017A	5.15	60	E	0.78	0.051	36.0	0.025	0.03
Measurement Grid									
Test Position	Height (cm)	% of Control Limit		Test Position	Height (cm)	% of Control Limit		IEEE Controlled Limit	IEEE Uncontrolled Limit
1	20	0.1%		6	120	0.1%		2.55	0.51
2	40	0.1%		7	140	0.9%			
3	60	0.1%		8	160	3.6%			
4	80	0.1%		9	180	6.8%			
5	100	0.1%		10	200	8.1%			
								RF Po (*Max)	36.0

P-Position 1

Table 56

Internal Vehicle MPE Assessment @ 764.0875 MHz										
Antenna Location	Antenna Model	Gain (dBi)	Meas. Distance (cm)	E/H Field	Calibration Factor	Average over Head, Chest, Lower Trunk Back/Front seats (mW/cm ²)		Initial Power (W)	Pwr. Density Calc. (mW/cm ²)	Pwr. Density Max Calc. (mW/cm ²)
						Back	Front			
Roof (cnt)	HAF4017A	5.15	Highest Reading	E	0.78	0.006	0.003	36.0	0.003	0.00
Measurement Grid										
Test Position		% of Control Limit Head		% of Control Limit Chest		% of Control Limit Lower Trunk		IEEE Controlled Limit:		2.55
Back Seat		0.2%		0.3%		0.2%		IEEE Uncontrolled Limit:		0.51
Front Seat		0.2%		0.1%		0.1%		RF Po (*Max):		36.0

BS-Position 1

Table 57

External Vehicle MPE Assessment @ 773.0125 MHz									
Antenna Location	Antenna Model	Gain (dBi)	Meas. Distance (cm)	E/H Field	Calibration Factor	Average over Body (mW/cm ²)	Initial Power (W)	Pwr. Density Calc. (mW/cm ²)	Pwr. Density Max Calc. (mW/cm ²)
Roof (cnt)	HAF4017A	5.15	60	E	0.78	0.049	36.0	0.024	0.02
Measurement Grid									
Test Position	Height (cm)	% of Control Limit		Test Position	Height (cm)	% of Control Limit		IEEE Controlled Limit	IEEE Uncontrolled Limit
1	20	0.1%		6	120	0.4%		2.58	0.52
2	40	0.1%		7	140	1.2%			
3	60	0.1%		8	160	3.9%			
4	80	0.1%		9	180	6.4%			
5	100	0.1%		10	200	6.7%			
								RF Po (*Max)	36.0

7/800MHz Mobile M20URS9PW1AN

P-Position 1

Table 58

Internal Vehicle MPE Assessment @ 773.0125 MHz										
Antenna Location	Antenna	Gain (dBi)	Meas. Distance (cm)	E/H Field	Calibration Factor	Average over Head, Chest, Lower Trunk Back/Front seats (mW/cm ²)		Initial Power (W)	Pwr. Density Calc. (mW/cm ²)	Pwr. Density Max Calc. (mW/cm ²)
						Back	Front			
Roof (cnt)	HAF4017A	5.15	Highest Reading	E	0.78	0.006	0.003	36.0	0.003	0.00
Measurement Grid										
Test Position		% of Control Limit Head		% of Control Limit Chest		% of Control Limit Lower Trunk		IEEE Controlled Limit:		2.58
Back Seat		0.2%		0.3%		0.2%		IEEE Uncontrolled Limit:		0.52
Front Seat		0.2%		0.1%		0.1%		RF Po (*Max):		36.0

BS-Position 1

Table 59

External Vehicle MPE Assessment @ 775.9125 MHz										
Antenna Location	Antenna Model	Gain (dBi)	Meas. Distance (cm)	E/H Field	Calibration Factor	Average over Body (mW/cm ²)	Initial Power (W)	Pwr. Density Calc. (mW/cm ²)	Pwr. Density Max Calc. (mW/cm ²)	
Roof (cnt)	HAF4017A	5.15	60	E	0.77	0.054	36.1	0.027	0.03	
Measurement Grid										
Test Position	Height (cm)	% of Control Limit		Test Position	Height (cm)	% of Control Limit		IEEE Controlled Limit	IEEE Uncontrolled Limit	
1	20	0.0%		6	120	0.5%		2.59	0.52	
2	40	0.1%		7	140	1.5%				
3	60	0.1%		8	160	4.0%				
4	80	0.1%		9	180	7.7%				
5	100	0.1%		10	200	7.0%				
								RF Po (*Max):		36.0

P-Position 1

Table 60

Internal Vehicle MPE Assessment @ 775.9125 MHz										
Antenna Location	Antenna	Gain (dBi)	Meas. Distance (cm)	E/H Field	Calibration Factor	Average over Head, Chest, Lower Trunk Back/Front seats (mW/cm ²)		Initial Power (W)	Pwr. Density Calc. (mW/cm ²)	Pwr. Density Max Calc. (mW/cm ²)
						Back	Front			
Roof (cnt)	HAF4017A	5.15	Highest Reading	E	0.77	0.004	0.003	36.1	0.002	0.00
Measurement Grid										
Test Position		% of Control Limit Head		% of Control Limit Chest		% of Control Limit Lower Trunk		IEEE Controlled Limit:		2.59
Back Seat		0.2%		0.2%		0.1%		IEEE Uncontrolled Limit:		0.52
Front Seat		0.1%		0.1%		0.1%		RF Po (*Max):		36.0

7/800MHz Mobile M20URS9PW1AN

BS-Position 1

Table 61

External Vehicle MPE Assessment @ 794.0875 MHz									
Antenna Location	Antenna Model	Gain (dBi)	Meas. Distance (cm)	E/H Field	Calibration Factor	Average over Body (mW/cm ²)	Initial Power (W)	Pwr. Density Calc. (mW/cm ²)	Pwr. Density Max Calc. (mW/cm ²)
Roof (cnt)	HAF4017A	5.15	60	E	0.76	0.065	37.0	0.032	0.03
Measurement Grid									
Test Position	Height (cm)	% of Control Limit		Test Position	Height (cm)	% of Control Limit		IEEE Controlled Limit	IEEE Uncontrolled Limit
1	20	0.1%		6	120	1.4%		2.65	0.53
2	40	0.1%		7	140	3.4%			
3	60	0.1%		8	160	5.3%			
4	80	0.2%		9	180	7.7%			
5	100	0.6%		10	200	5.6%			
								RF Po (*Max)	
								36.0	

P-Position 1

Table 62

Internal Vehicle MPE Assessment @ 794.0875 MHz										
Antenna Location	Antenna Model	Gain (dBi)	Meas. Distance (cm)	E/H Field	Calibration Factor	Average over Head, Chest, Lower Trunk Back/Front seats (mW/cm ²)		Initial Power (W)	Pwr. Density Calc. (mW/cm ²)	Pwr. Density Max Calc. (mW/cm ²)
						Back	Front			
Roof (cnt)	HAF4017A	5.15	Highest Reading	E	0.76	0.015	0.007	37.0	0.007	0.01
Measurement Grid										
Test Position		% of Control Limit Head		% of Control Limit Chest		% of Control Limit Lower Trunk		IEEE Controlled Limit:		2.65
Back Seat		0.5%		0.9%		0.3%		IEEE Uncontrolled Limit:		0.53
Front Seat		0.2%		0.2%		0.4%		RF Po (*Max):		36.0

BS-Position 1

Table 63

External Vehicle MPE Assessment @ 809.0125 MHz									
Antenna Location	Antenna Model	Gain (dBi)	Meas. Distance (cm)	E/H Field	Calibration Factor	Average over Body (mW/cm ²)	Initial Power (W)	Pwr. Density Calc. (mW/cm ²)	Pwr. Density Max Calc. (mW/cm ²)
Roof (cnt)	HAF4017A	5.15	60	E	0.75	0.094	41.3	0.047	0.05
Measurement Grid									
Test Position	Height (cm)	% of Control Limit		Test Position	Height (cm)	% of Control Limit		IEEE Controlled Limit	IEEE Uncontrolled Limit
1	20	0.1%		6	120	3.1%		2.70	0.54
2	40	0.2%		7	140	6.0%			
3	60	0.2%		8	160	7.9%			
4	80	0.3%		9	180	9.1%			
5	100	1.1%		10	200	6.9%			
								RF Po (*Max)	
								42.0	

7/800MHz Mobile M20URS9PW1AN

P-Position 1

Table 64

Internal Vehicle MPE Assessment @ 809.0125 MHz										
Antenna Location	Antenna	Gain (dBi)	Meas. Distance (cm)	E/H Field	Calibration Factor	Average over Head, Chest, Lower Trunk Back/Front seats (mW/cm ²)		Initial Power (W)	Pwr. Density Calc. (mW/cm ²)	Pwr. Density Max Calc. (mW/cm ²)
						Back	Front			
Roof (cnt)	HAF4017A	5.15	Highest Reading	E	0.75	0.024	0.017	41.3	0.012	0.01
Measurement Grid										
Test Position		% of Control Limit Head		% of Control Limit Chest		% of Control Limit Lower Trunk		IEEE Controlled Limit:		2.70
Back Seat		1.0%		1.2%		0.5%		IEEE Uncontrolled Limit:		0.54
Front Seat		0.5%		0.7%		0.7%		RF Po (*Max):		42.0

BS-Position 1

Table 65

External Vehicle MPE Assessment @ 823.9875 MHz										
Antenna Location	Antenna Model	Gain (dBi)	Meas. Distance (cm)	E/H Field	Calibration Factor	Average over Body (mW/cm ²)	Initial Power (W)	Pwr. Density Calc. (mW/cm ²)	Pwr. Density Max Calc. (mW/cm ²)	
										Roof (cnt)
Measurement Grid										
Test Position	Height (cm)	% of Control Limit		Test Position	Height (cm)	% of Control Limit		IEEE Controlled Limit	IEEE Uncontrolled Limit	
1	20	0.1%		6	120	2.8%		2.75	0.55	
2	40	0.2%		7	140	5.7%				
3	60	0.2%		8	160	8.9%				
4	80	0.8%		9	180	8.9%				
5	100	2.0%		10	200	7.0%				
								RF Po (*Max)		42.0

P-Position 1

Table 66

Internal Vehicle MPE Assessment @ 823.9875 MHz										
Antenna Location	Antenna	Gain (dBi)	Meas. Distance (cm)	E/H Field	Calibration Factor	Average over Head, Chest, Lower Trunk Back/Front seats (mW/cm ²)		Initial Power (W)	Pwr. Density Calc. (mW/cm ²)	Pwr. Density Max Calc. (mW/cm ²)
						Back	Front			
Roof (cnt)	HAF4017A	5.15	Highest Reading	E	0.74	0.043	0.026	41.6	0.022	0.02
Measurement Grid										
Test Position		% of Control Limit Head		% of Control Limit Chest		% of Control Limit Lower Trunk		IEEE Controlled Limit:		2.75
Back Seat		1.8%		1.9%		1.0%		IEEE Uncontrolled Limit:		0.55
Front Seat		0.8%		0.9%		1.1%		RF Po (*Max):		42.0

7/800MHz Mobile M20URS9PW1AN

BS-Position 1

Table 67

External Vehicle MPE Assessment @ 851.0125 MHz									
Antenna Location	Antenna Model	Gain (dBi)	Meas. Distance (cm)	E/H Field	Calibration Factor	Average over Body (mW/cm ²)	Initial Power (W)	Pwr. Density Calc. (mW/cm ²)	Pwr. Density Max Calc. (mW/cm ²)
Roof (cnt)	HAF4017A	5.15	60	E	0.73	0.102	41.9	0.051	0.05
Measurement Grid									
Test Position	Height (cm)	% of Control Limit		Test Position	Height (cm)	% of Control Limit		IEEE Controlled Limit	IEEE Uncontrolled Limit
1	20	0.2%		6	120	3.1%		2.84	0.57
2	40	0.1%		7	140	6.7%			
3	60	0.6%		8	160	10.5%			
4	80	1.0%		9	180	7.0%			
5	100	1.9%		10	200	5.0%			
								RF Po (*Max)	42.0

P-Position 1

Table 68

Internal Vehicle MPE Assessment @ 851.0125 MHz										
Antenna Location	Antenna Model	Gain (dBi)	Meas. Distance (cm)	E/H Field	Calibration Factor	Average over Head, Chest, Lower Trunk, Back/Front seats (mW/cm ²)		Initial Power (W)	Pwr. Density Calc. (mW/cm ²)	Pwr. Density Max Calc. (mW/cm ²)
						Back	Front			
Roof (cnt)	HAF4017A	5.15	Highest Reading	E	0.73	0.034	0.021	41.9	0.017	0.02
Measurement Grid										
Test Position		% of Control Limit Head		% of Control Limit Chest		% of Control Limit Lower Trunk		IEEE Controlled Limit:		2.84
Back Seat		0.6%		1.0%		2.0%		IEEE Uncontrolled Limit:		0.57
Front Seat		0.4%		0.9%		0.9%		RF Po (*Max):		42.0

BS-Position 1

Table 69

External Vehicle MPE Assessment @ 859.0125 MHz									
Antenna Location	Antenna Model	Gain (dBi)	Meas. Distance (cm)	E/H Field	Calibration Factor	Average over Body (mW/cm ²)	Initial Power (W)	Pwr. Density Calc. (mW/cm ²)	Pwr. Density Max Calc. (mW/cm ²)
Roof (cnt)	HAF4017A	5.15	60	E	0.72	0.093	41.7	0.047	0.05
Measurement Grid									
Test Position	Height (cm)	% of Control Limit		Test Position	Height (cm)	% of Control Limit		IEEE Controlled Limit	IEEE Uncontrolled Limit
1	20	0.1%		6	120	3.0%		2.86	0.57
2	40	0.3%		7	140	7.0%			
3	60	0.4%		8	160	9.0%			
4	80	1.0%		9	180	5.8%			
5	100	1.6%		10	200	4.4%			
								RF Po (*Max)	42.0

7/800MHz Mobile M20URS9PW1AN

P-Position 1

Table 70

Internal Vehicle MPE Assessment @ 859.0125 MHz										
Antenna Location	Antenna	Gain (dBi)	Meas. Distance (cm)	E/H Field	Calibration Factor	Average over Head, Chest, Lower Trunk Back/Front seats (mW/cm ²)		Initial Power (W)	Pwr. Density Calc. (mW/cm ²)	Pwr. Density Max Calc. (mW/cm ²)
						Back	Front			
Roof (cnt)	HAF4017A	5.15	Highest Reading	E	0.72	0.022	0.025	41.7	0.012	0.01
Measurement Grid										
Test Position		% of Control Limit Head		% of Control Limit Chest		% of Control Limit Lower Trunk		IEEE Controlled Limit:		2.86
Back Seat		0.3%		0.7%		1.3%		IEEE Uncontrolled Limit:		0.57
Front Seat		0.8%		1.1%		0.7%		RF Po (*Max):		42.0

BS-Position 1

Table 71

External Vehicle MPE Assessment @ 868.9875 MHz									
Antenna Location	Antenna Model	Gain (dBi)	Meas. Distance (cm)	E/H Field	Calibration Factor	Average over Body (mW/cm ²)	Initial Power (W)	Pwr. Density Calc. (mW/cm ²)	Pwr. Density Max Calc. (mW/cm ²)
Roof (cnt)	HAF4017A	5.15	60	E	0.71	0.081	41.9	0.040	0.04
Measurement Grid									
Test Position	Height (cm)	% of Control Limit		Test Position	Height (cm)	% of Control Limit		IEEE Controlled Limit	IEEE Uncontrolled Limit
1	20	0.1%		6	120	2.5%		RF Po (*Max)	0.58
2	40	0.2%		7	140	6.8%			
3	60	0.4%		8	160	6.6%			
4	80	1.1%		9	180	4.9%			
5	100	1.2%		10	200	4.1%			42.0

P-Position 1

Table 72

Internal Vehicle MPE Assessment @ 868.9875 MHz										
Antenna Location	Antenna	Gain (dBi)	Meas. Distance (cm)	E/H Field	Calibration Factor	Average over Head, Chest, Lower Trunk Back/Front seats (mW/cm ²)		Initial Power (W)	Pwr. Density Calc. (mW/cm ²)	Pwr. Density Max Calc. (mW/cm ²)
						Back	Front			
Roof (cnt)	HAF4017A	5.15	Highest Reading	E	0.71	0.018	0.022	41.9	0.011	0.01
Measurement Grid										
Test Position		% of Control Limit Head		% of Control Limit Chest		% of Control Limit Lower Trunk		IEEE Controlled Limit:		2.90
Back Seat		0.9%		0.7%		0.3%		IEEE Uncontrolled Limit:		0.58
Front Seat		0.5%		0.9%		0.9%		RF Po (*Max):		42.0

7/800MHz Mobile M20URS9PW1AN

BS-Position 2

Table 73

External Vehicle MPE Assessment @ 764.0875 MHz									
Antenna Location	Antenna Model	Gain (dBi)	Meas. Distance (cm)	E/H Field	Calibration Factor	Average over Body (mW/cm ²)	Initial Power (W)	Pwr. Density Calc. (mW/cm ²)	Pwr. Density Max Calc. (mW/cm ²)
Roof (cnt)	HAF4016A	2.15	60	E	0.78	0.062	36.0	0.031	0.03
Measurement Grid									
Test Position	Height (cm)	% of Control Limit			Test Position	Height (cm)	% of Control Limit		
1	20	0.1%			6	120	2.0%		
2	40	0.1%			7	140	3.8%		
3	60	0.3%			8	160	4.7%		
4	80	0.8%			9	180	6.0%		
5	100	1.3%			10	200	5.1%		
								IEEE Controlled Limit	IEEE Uncontrolled Limit
									RF Po (*Max)
									36.0

BS-Position 2

Table 74

External Vehicle MPE Assessment @ 773.0125 MHz									
Antenna Location	Antenna Model	Gain (dBi)	Meas. Distance (cm)	E/H Field	Calibration Factor	Average over Body (mW/cm ²)	Initial Power (W)	Pwr. Density Calc. (mW/cm ²)	Pwr. Density Max Calc. (mW/cm ²)
Roof (cnt)	HAF4016A	2.15	60	E	0.78	0.061	36.0	0.031	0.03
Measurement Grid									
Test Position	Height (cm)	% of Control Limit			Test Position	Height (cm)	% of Control Limit		
1	20	0.1%			6	120	2.0%		
2	40	0.1%			7	140	3.2%		
3	60	0.3%			8	160	4.8%		
4	80	0.6%			9	180	5.8%		
5	100	1.5%			10	200	5.4%		
								IEEE Controlled Limit	IEEE Uncontrolled Limit
									RF Po (*Max)
									36.0

BS-Position 2

Table 75

External Vehicle MPE Assessment @ 775.9125 MHz									
Antenna Location	Antenna Model	Gain (dBi)	Meas. Distance (cm)	E/H Field	Calibration Factor	Average over Body (mW/cm ²)	Initial Power (W)	Pwr. Density Calc. (mW/cm ²)	Pwr. Density Max Calc. (mW/cm ²)
Roof (cnt)	HAF4016A	2.15	60	E	0.77	0.065	36.1	0.033	0.03
Measurement Grid									
Test Position	Height (cm)	% of Control Limit			Test Position	Height (cm)	% of Control Limit		
1	20	0.1%			6	120	1.8%		
2	40	0.2%			7	140	3.2%		
3	60	0.4%			8	160	4.5%		
4	80	0.7%			9	180	7.0%		
5	100	1.7%			10	200	5.6%		
								IEEE Controlled Limit	IEEE Uncontrolled Limit
									RF Po (*Max)
									36.0

7/800MHz Mobile M20URS9PW1AN

BS-Position 2

Table 76

External Vehicle MPE Assessment @ 794.0875 MHz									
Antenna Location	Antenna Model	Gain (dBi)	Meas. Distance (cm)	E/H Field	Calibration Factor	Average over Body (mW/cm ²)	Initial Power (W)	Pwr. Density Calc. (mW/cm ²)	Pwr. Density Max Calc. (mW/cm ²)
Roof (cnt)	HAF4016A	2.15	60	E	0.76	0.060	37.0	0.030	0.03
Measurement Grid									
Test Position	Height (cm)	% of Control Limit		Test Position	Height (cm)	% of Control Limit		IEEE Controlled Limit	IEEE Uncontrolled Limit
1	20	0.2%		6	120	1.2%		2.65	0.53
2	40	0.3%		7	140	2.5%			
3	60	0.4%		8	160	4.5%			
4	80	0.9%		9	180	6.9%			
5	100	1.1%		10	200	4.7%			
								RF Po (*Max)	
								36.0	

BS-Position 2

Table 77

External Vehicle MPE Assessment @ 809.0125 MHz									
Antenna Location	Antenna Model	Gain (dBi)	Meas. Distance (cm)	E/H Field	Calibration Factor	Average over Body (mW/cm ²)	Initial Power (W)	Pwr. Density Calc. (mW/cm ²)	Pwr. Density Max Calc. (mW/cm ²)
Roof (cnt)	HAF4016A	2.15	60	E	0.75	0.083	41.3	0.042	0.04
Measurement Grid									
Test Position	Height (cm)	% of Control Limit		Test Position	Height (cm)	% of Control Limit		IEEE Controlled Limit	IEEE Uncontrolled Limit
1	20	0.1%		6	120	2.1%		2.70	0.54
2	40	0.4%		7	140	4.3%			
3	60	0.8%		8	160	7.5%			
4	80	0.9%		9	180	7.6%			
5	100	1.1%		10	200	6.1%			
								RF Po (*Max)	
								42.0	

BS-Position 2

Table 78

External Vehicle MPE Assessment @ 823.9875 MHz									
Antenna Location	Antenna Model	Gain (dBi)	Meas. Distance (cm)	E/H Field	Calibration Factor	Average over Body (mW/cm ²)	Initial Power (W)	Pwr. Density Calc. (mW/cm ²)	Pwr. Density Max Calc. (mW/cm ²)
Roof (cnt)	HAF4016A	2.15	60	E	0.74	0.061	41.6	0.031	0.03
Measurement Grid									
Test Position	Height (cm)	% of Control Limit		Test Position	Height (cm)	% of Control Limit		IEEE Controlled Limit	IEEE Uncontrolled Limit
1	20	0.3%		6	120	1.2%		2.75	0.55
2	40	0.4%		7	140	3.1%			
3	60	0.6%		8	160	4.7%			
4	80	0.9%		9	180	5.4%			
5	100	0.9%		10	200	4.8%			
								RF Po (*Max)	
								42.0	

7/800MHz Mobile M20URS9PW1AN

BS-Position 2

Table 79

External Vehicle MPE Assessment @ 851.0125 MHz									
Antenna Location	Antenna Model	Gain (dBi)	Meas. Distance (cm)	E/H Field	Calibration Factor	Average over Body (mW/cm ²)	Initial Power (W)	Pwr. Density Calc. (mW/cm ²)	Pwr. Density Max Calc. (mW/cm ²)
Roof (cnt)	HAF4016A	2.15	60	E	0.73	0.059	41.9	0.029	0.03
Measurement Grid									
Test Position	Height (cm)	% of Control Limit		Test Position	Height (cm)	% of Control Limit		IEEE Controlled Limit	IEEE Uncontrolled Limit
1	20	0.5%		6	120	2.0%		2.84	0.57
2	40	0.6%		7	140	3.1%			
3	60	0.6%		8	160	3.4%			
4	80	0.7%		9	180	4.6%			
5	100	0.9%		10	200	4.3%			
								RF Po (*Max)	42.0

BS-Position 2

Table 80

External Vehicle MPE Assessment @ 859.0125 MHz									
Antenna Location	Antenna Model	Gain (dBi)	Meas. Distance (cm)	E/H Field	Calibration Factor	Average over Body (mW/cm ²)	Initial Power (W)	Pwr. Density Calc. (mW/cm ²)	Pwr. Density Max Calc. (mW/cm ²)
Roof (cnt)	HAF4016A	2.15	60	E	0.72	0.062	41.7	0.031	0.03
Measurement Grid									
Test Position	Height (cm)	% of Control Limit		Test Position	Height (cm)	% of Control Limit		IEEE Controlled Limit	IEEE Uncontrolled Limit
1	20	0.2%		6	120	2.2%		2.86	0.57
2	40	0.3%		7	140	3.1%			
3	60	0.5%		8	160	3.8%			
4	80	0.7%		9	180	5.2%			
5	100	0.9%		10	200	4.8%			
								RF Po (*Max)	42.0

BS-Position 2

Table 81

External Vehicle MPE Assessment @ 868.9875 MHz									
Antenna Location	Antenna Model	Gain (dBi)	Meas. Distance (cm)	E/H Field	Calibration Factor	Average over Body (mW/cm ²)	Initial Power (W)	Pwr. Density Calc. (mW/cm ²)	Pwr. Density Max Calc. (mW/cm ²)
Roof (cnt)	HAF4016A	2.15	60	E	0.71	0.065	41.9	0.032	0.03
Measurement Grid									
Test Position	Height (cm)	% of Control Limit		Test Position	Height (cm)	% of Control Limit		IEEE Controlled Limit	IEEE Uncontrolled Limit
1	20	0.3%		6	120	2.1%		2.90	0.58
2	40	0.4%		7	140	3.2%			
3	60	0.4%		8	160	3.9%			
4	80	0.8%		9	180	5.3%			
5	100	1.1%		10	200	4.8%			
								RF Po (*Max)	42.0

7/800MHz Mobile M20URS9PW1AN

BS-Position 2

Table 82

External Vehicle MPE Assessment @ 764.0875 MHz									
Antenna Location	Antenna Model	Gain (dBi)	Meas. Distance (cm)	E/H Field	Calibration Factor	Average over Body (mW/cm ²)	Initial Power (W)	Pwr. Density Calc. (mW/cm ²)	Pwr. Density Max Calc. (mW/cm ²)
Roof (cnt)	HAF4014A	5.15	60	E	0.78	0.089	36.0	0.045	0.04
Measurement Grid									
Test Position	Height (cm)	% of Control Limit			Test Position	Height (cm)	% of Control Limit		
1	20	0.5%			6	120	4.6%		
2	40	0.5%			7	140	5.8%		
3	60	0.7%			8	160	7.3%		
4	80	1.4%			9	180	7.3%		
5	100	2.9%			10	200	4.1%		
								IEEE Controlled Limit	IEEE Uncontrolled Limit
									RF Po (*Max)
									36.0

BS-Position 2

Table 83

External Vehicle MPE Assessment @ 773.0125 MHz									
Antenna Location	Antenna Model	Gain (dBi)	Meas. Distance (cm)	E/H Field	Calibration Factor	Average over Body (mW/cm ²)	Initial Power (W)	Pwr. Density Calc. (mW/cm ²)	Pwr. Density Max Calc. (mW/cm ²)
Roof (cnt)	HAF4014A	5.15	60	E	0.78	0.102	36.0	0.051	0.05
Measurement Grid									
Test Position	Height (cm)	% of Control Limit			Test Position	Height (cm)	% of Control Limit		
1	20	0.4%			6	120	4.6%		
2	40	0.5%			7	140	6.2%		
3	60	1.0%			8	160	8.3%		
4	80	1.3%			9	180	8.4%		
5	100	3.7%			10	200	5.1%		
								IEEE Controlled Limit	IEEE Uncontrolled Limit
									RF Po (*Max)
									36.0

BS-Position 2

Table 84

External Vehicle MPE Assessment @ 775.9125 MHz									
Antenna Location	Antenna Model	Gain (dBi)	Meas. Distance (cm)	E/H Field	Calibration Factor	Average over Body (mW/cm ²)	Initial Power (W)	Pwr. Density Calc. (mW/cm ²)	Pwr. Density Max Calc. (mW/cm ²)
Roof (cnt)	HAF4014A	5.15	60	E	0.77	0.109	36.1	0.054	0.05
Measurement Grid									
Test Position	Height (cm)	% of Control Limit			Test Position	Height (cm)	% of Control Limit		
1	20	0.3%			6	120	4.3%		
2	40	0.4%			7	140	7.5%		
3	60	1.2%			8	160	9.7%		
4	80	1.4%			9	180	8.7%		
5	100	3.9%			10	200	4.7%		
								IEEE Controlled Limit	IEEE Uncontrolled Limit
									RF Po (*Max)
									36.0

7/800MHz Mobile M20URS9PW1AN

BS-Position 2

Table 85

External Vehicle MPE Assessment @ 794.0875 MHz									
Antenna Location	Antenna Model	Gain (dBi)	Meas. Distance (cm)	E/H Field	Calibration Factor	Average over Body (mW/cm ²)	Initial Power (W)	Pwr. Density Calc. (mW/cm ²)	Pwr. Density Max Calc. (mW/cm ²)
Roof (cnt)	HAF4014A	5.15	60	E	0.76	0.099	37.0	0.049	0.05
Measurement Grid									
Test Position	Height (cm)	% of Control Limit		Test Position	Height (cm)	% of Control Limit		IEEE Controlled Limit	IEEE Uncontrolled Limit
1	20	0.4%		6	120	3.1%		2.65	0.53
2	40	0.6%		7	140	5.4%			
3	60	1.2%		8	160	8.8%			
4	80	1.5%		9	180	9.0%			
5	100	2.6%		10	200	4.8%			
								RF Po (*Max)	
								36.0	

BS-Position 2

Table 86

External Vehicle MPE Assessment @ 809.0125 MHz									
Antenna Location	Antenna Model	Gain (dBi)	Meas. Distance (cm)	E/H Field	Calibration Factor	Average over Body (mW/cm ²)	Initial Power (W)	Pwr. Density Calc. (mW/cm ²)	Pwr. Density Max Calc. (mW/cm ²)
Roof (cnt)	HAF4014A	5.15	60	E	0.75	0.122	41.3	0.061	0.06
Measurement Grid									
Test Position	Height (cm)	% of Control Limit		Test Position	Height (cm)	% of Control Limit		IEEE Controlled Limit	IEEE Uncontrolled Limit
1	20	0.4%		6	120	3.4%		2.70	0.54
2	40	0.8%		7	140	8.3%			
3	60	1.4%		8	160	11.6%			
4	80	1.5%		9	180	10.5%			
5	100	2.0%		10	200	5.2%			
								RF Po (*Max)	
								42.0	

BS-Position 2

Table 87

External Vehicle MPE Assessment @ 823.9875 MHz									
Antenna Location	Antenna Model	Gain (dBi)	Meas. Distance (cm)	E/H Field	Calibration Factor	Average over Body (mW/cm ²)	Initial Power (W)	Pwr. Density Calc. (mW/cm ²)	Pwr. Density Max Calc. (mW/cm ²)
Roof (cnt)	HAF4014A	5.15	60	E	0.74	0.090	41.6	0.045	0.05
Measurement Grid									
Test Position	Height (cm)	% of Control Limit		Test Position	Height (cm)	% of Control Limit		IEEE Controlled Limit	IEEE Uncontrolled Limit
1	20	0.4%		6	120	2.4%		2.75	0.55
2	40	0.6%		7	140	7.3%			
3	60	1.0%		8	160	7.9%			
4	80	1.0%		9	180	7.0%			
5	100	1.1%		10	200	4.1%			
								RF Po (*Max)	
								42.0	

7/800MHz Mobile M20URS9PW1AN

BS-Position 2

Table 88

External Vehicle MPE Assessment @ 851.0125 MHz									
Antenna Location	Antenna Model	Gain (dBi)	Meas. Distance (cm)	E/H Field	Calibration Factor	Average over Body (mW/cm ²)	Initial Power (W)	Pwr. Density Calc. (mW/cm ²)	Pwr. Density Max Calc. (mW/cm ²)
Roof (cnt)	HAF4014A	5.15	60	E	0.73	0.075	41.9	0.038	0.04
Measurement Grid									
Test Position	Height (cm)	% of Control Limit			Test Position	Height (cm)	% of Control Limit		
1	20	0.3%			6	120	3.3%		
2	40	0.3%			7	140	4.6%		
3	60	0.6%			8	160	5.7%		
4	80	0.8%			9	180	6.1%		
5	100	1.3%			10	200	3.6%		
								IEEE Controlled Limit	IEEE Uncontrolled Limit
								2.84	0.57
								RF Po (*Max)	
								42.0	

BS-Position 2

Table 89

External Vehicle MPE Assessment @ 859.0125 MHz									
Antenna Location	Antenna Model	Gain (dBi)	Meas. Distance (cm)	E/H Field	Calibration Factor	Average over Body (mW/cm ²)	Initial Power (W)	Pwr. Density Calc. (mW/cm ²)	Pwr. Density Max Calc. (mW/cm ²)
Roof (cnt)	HAF4014A	5.15	60	E	0.72	0.072	41.7	0.036	0.04
Measurement Grid									
Test Position	Height (cm)	% of Control Limit			Test Position	Height (cm)	% of Control Limit		
1	20	0.2%			6	120	2.7%		
2	40	0.4%			7	140	4.6%		
3	60	0.5%			8	160	4.8%		
4	80	0.6%			9	180	5.4%		
5	100	1.5%			10	200	4.4%		
								IEEE Controlled Limit	IEEE Uncontrolled Limit
								2.86	0.57
								RF Po (*Max)	
								42.0	

BS-Position 2

Table 90

External Vehicle MPE Assessment @ 868.9875 MHz									
Antenna Location	Antenna Model	Gain (dBi)	Meas. Distance (cm)	E/H Field	Calibration Factor	Average over Body (mW/cm ²)	Initial Power (W)	Pwr. Density Calc. (mW/cm ²)	Pwr. Density Max Calc. (mW/cm ²)
Roof (cnt)	HAF4014A	5.15	60	E	0.71	0.075	41.9	0.038	0.04
Measurement Grid									
Test Position	Height (cm)	% of Control Limit			Test Position	Height (cm)	% of Control Limit		
1	20	0.3%			6	120	3.6%		
2	40	0.3%			7	140	4.2%		
3	60	0.5%			8	160	4.2%		
4	80	0.6%			9	180	6.0%		
5	100	1.6%			10	200	4.7%		
								IEEE Controlled Limit	IEEE Uncontrolled Limit
								2.90	0.58
								RF Po (*Max)	
								42.0	

7/800MHz Mobile M20URS9PW1AN

BS-Position 2

Table 91

External Vehicle MPE Assessment @ 764.0875 MHz									
Antenna Location	Antenna Model	Gain (dBi)	Meas. Distance (cm)	E/H Field	Calibration Factor	Average over Body (mW/cm ²)	Initial Power (W)	Pwr. Density Calc. (mW/cm ²)	Pwr. Density Max Calc. (mW/cm ²)
Roof (cnt)	HAF4013A	5.15	60	E	0.78	0.064	36.0	0.032	0.03
Measurement Grid									
Test Position	Height (cm)	% of Control Limit		Test Position	Height (cm)	% of Control Limit		IEEE Controlled Limit	IEEE Uncontrolled Limit
1	20	0.2%		6	120	2.5%		2.55	0.51
2	40	0.3%		7	140	3.1%			
3	60	0.5%		8	160	4.6%			
4	80	0.7%		9	180	5.6%			
5	100	1.5%		10	200	6.3%			RF Po (*Max)
									36.0

BS-Position 2

Table 92

External Vehicle MPE Assessment @ 773.0125 MHz									
Antenna Location	Antenna Model	Gain (dBi)	Meas. Distance (cm)	E/H Field	Calibration Factor	Average over Body (mW/cm ²)	Initial Power (W)	Pwr. Density Calc. (mW/cm ²)	Pwr. Density Max Calc. (mW/cm ²)
Roof (cnt)	HAF4013A	5.15	60	E	0.78	0.068	36.0	0.034	0.03
Measurement Grid									
Test Position	Height (cm)	% of Control Limit		Test Position	Height (cm)	% of Control Limit		IEEE Controlled Limit	IEEE Uncontrolled Limit
1	20	0.2%		6	120	2.2%		2.58	0.52
2	40	0.2%		7	140	3.3%			
3	60	0.5%		8	160	4.8%			
4	80	0.8%		9	180	5.8%			
5	100	1.9%		10	200	6.5%			RF Po (*Max)
									36.0

BS-Position 2

Table 93

External Vehicle MPE Assessment @ 775.9125 MHz									
Antenna Location	Antenna Model	Gain (dBi)	Meas. Distance (cm)	E/H Field	Calibration Factor	Average over Body (mW/cm ²)	Initial Power (W)	Pwr. Density Calc. (mW/cm ²)	Pwr. Density Max Calc. (mW/cm ²)
Roof (cnt)	HAF4013A	5.15	60	E	0.77	0.063	36.1	0.032	0.03
Measurement Grid									
Test Position	Height (cm)	% of Control Limit		Test Position	Height (cm)	% of Control Limit		IEEE Controlled Limit	IEEE Uncontrolled Limit
1	20	0.1%		6	120	1.7%		2.59	0.52
2	40	0.3%		7	140	2.4%			
3	60	0.4%		8	160	4.7%			
4	80	0.9%		9	180	6.2%			
5	100	1.3%		10	200	6.5%			RF Po (*Max)
									36.0

7/800MHz Mobile M20URS9PW1AN

BS-Position 2

Table 94

External Vehicle MPE Assessment @ 794.0875 MHz									
Antenna Location	Antenna Model	Gain (dBi)	Meas. Distance (cm)	E/H Field	Calibration Factor	Average over Body (mW/cm ²)	Initial Power (W)	Pwr. Density Calc. (mW/cm ²)	Pwr. Density Max Calc. (mW/cm ²)
Roof (cnt)	HAF4013A	5.15	60	E	0.76	0.061	37.0	0.030	0.03
Measurement Grid									
Test Position	Height (cm)	% of Control Limit			Test Position	Height (cm)	% of Control Limit		
1	20	0.2%			6	120	1.0%		
2	40	0.4%			7	140	2.1%		
3	60	0.7%			8	160	4.2%		
4	80	0.9%			9	180	6.4%		
5	100	1.0%			10	200	6.0%		
								IEEE Controlled Limit	IEEE Uncontrolled Limit
								2.65	0.53
								RF Po (*Max)	
								36.0	

BS-Position 2

Table 95

External Vehicle MPE Assessment @ 809.0125 MHz									
Antenna Location	Antenna Model	Gain (dBi)	Meas. Distance (cm)	E/H Field	Calibration Factor	Average over Body (mW/cm ²)	Initial Power (W)	Pwr. Density Calc. (mW/cm ²)	Pwr. Density Max Calc. (mW/cm ²)
Roof (cnt)	HAF4013A	5.15	60	E	0.75	0.074	41.3	0.037	0.04
Measurement Grid									
Test Position	Height (cm)	% of Control Limit			Test Position	Height (cm)	% of Control Limit		
1	20	0.2%			6	120	1.6%		
2	40	0.4%			7	140	3.4%		
3	60	0.9%			8	160	6.0%		
4	80	0.9%			9	180	7.1%		
5	100	1.0%			10	200	6.0%		
								IEEE Controlled Limit	IEEE Uncontrolled Limit
								2.70	0.54
								RF Po (*Max)	
								42.0	

BS-Position 2

Table 96

External Vehicle MPE Assessment @ 823.9875 MHz									
Antenna Location	Antenna Model	Gain (dBi)	Meas. Distance (cm)	E/H Field	Calibration Factor	Average over Body (mW/cm ²)	Initial Power (W)	Pwr. Density Calc. (mW/cm ²)	Pwr. Density Max Calc. (mW/cm ²)
Roof (cnt)	HAF4013A	5.15	60	E	0.74	0.065	41.6	0.033	0.03
Measurement Grid									
Test Position	Height (cm)	% of Control Limit			Test Position	Height (cm)	% of Control Limit		
1	20	0.3%			6	120	1.7%		
2	40	0.5%			7	140	3.3%		
3	60	0.7%			8	160	4.4%		
4	80	0.7%			9	180	5.7%		
5	100	1.0%			10	200	5.5%		
								IEEE Controlled Limit	IEEE Uncontrolled Limit
								2.75	0.55
								RF Po (*Max)	
								42.0	

7/800MHz Mobile M20URS9PW1AN

BS-Position 2

Table 97

External Vehicle MPE Assessment @ 851.0125 MHz									
Antenna Location	Antenna Model	Gain (dBi)	Meas. Distance (cm)	E/H Field	Calibration Factor	Average over Body (mW/cm ²)	Initial Power (W)	Pwr. Density Calc. (mW/cm ²)	Pwr. Density Max Calc. (mW/cm ²)
Roof (cnt)	HAF4013A	5.15	60	E	0.73	0.064	41.9	0.032	0.03
Measurement Grid									
Test Position	Height (cm)	% of Control Limit		Test Position	Height (cm)	% of Control Limit		IEEE Controlled Limit	IEEE Uncontrolled Limit
1	20	0.3%		6	120	2.0%		2.84	0.57
2	40	0.3%		7	140	3.3%			
3	60	0.5%		8	160	3.8%			
4	80	0.6%		9	180	5.3%			
5	100	0.9%		10	200	5.5%			
								RF Po (*Max)	42.0

BS-Position 2

Table 98

External Vehicle MPE Assessment @ 859.0125 MHz									
Antenna Location	Antenna Model	Gain (dBi)	Meas. Distance (cm)	E/H Field	Calibration Factor	Average over Body (mW/cm ²)	Initial Power (W)	Pwr. Density Calc. (mW/cm ²)	Pwr. Density Max Calc. (mW/cm ²)
Roof (cnt)	HAF4013A	5.15	60	E	0.72	0.072	41.7	0.036	0.04
Measurement Grid									
Test Position	Height (cm)	% of Control Limit		Test Position	Height (cm)	% of Control Limit		IEEE Controlled Limit	IEEE Uncontrolled Limit
1	20	0.3%		6	120	2.6%		2.86	0.57
2	40	0.4%		7	140	3.7%			
3	60	0.5%		8	160	3.9%			
4	80	0.7%		9	180	5.6%			
5	100	1.3%		10	200	6.0%			
								RF Po (*Max)	42.0

BS-Position 2

Table 99

External Vehicle MPE Assessment @ 868.9875 MHz									
Antenna Location	Antenna Model	Gain (dBi)	Meas. Distance (cm)	E/H Field	Calibration Factor	Average over Body (mW/cm ²)	Initial Power (W)	Pwr. Density Calc. (mW/cm ²)	Pwr. Density Max Calc. (mW/cm ²)
Roof (cnt)	HAF4013A	5.15	60	E	0.71	0.071	41.9	0.035	0.04
Measurement Grid									
Test Position	Height (cm)	% of Control Limit		Test Position	Height (cm)	% of Control Limit		IEEE Controlled Limit	IEEE Uncontrolled Limit
1	20	0.3%		6	120	2.0%		2.90	0.58
2	40	0.3%		7	140	4.0%			
3	60	0.5%		8	160	4.6%			
4	80	0.7%		9	180	5.8%			
5	100	1.0%		10	200	5.3%			
								RF Po (*Max)	42.0

7/800MHz Mobile M20URS9PW1AN

BS-Position 2

Table 100

External Vehicle MPE Assessment @ 764.0875 MHz									
Antenna Location	Antenna Model	Gain (dBi)	Meas. Distance (cm)	E/H Field	Calibration Factor	Average over Body (mW/cm ²)	Initial Power (W)	Pwr. Density Calc. (mW/cm ²)	Pwr. Density Max Calc. (mW/cm ²)
Roof (cnt)	HAF4017A	5.15	60	E	0.78	0.037	36.0	0.019	0.02
Measurement Grid									
Test Position	Height (cm)	% of Control Limit		Test Position	Height (cm)	% of Control Limit		IEEE Controlled Limit	IEEE Uncontrolled Limit
1	20	0.0%		6	120	0.8%		2.55	0.51
2	40	0.0%		7	140	1.4%			
3	60	0.1%		8	160	2.5%			
4	80	0.1%		9	180	4.0%			
5	100	0.3%		10	200	5.3%			
								RF Po (*Max)	36.0

BS-Position 2

Table 101

External Vehicle MPE Assessment @ 773.0125 MHz									
Antenna Location	Antenna Model	Gain (dBi)	Meas. Distance (cm)	E/H Field	Calibration Factor	Average over Body (mW/cm ²)	Initial Power (W)	Pwr. Density Calc. (mW/cm ²)	Pwr. Density Max Calc. (mW/cm ²)
Roof (cnt)	HAF4017A	5.15	60	E	0.78	0.034	36.0	0.017	0.02
Measurement Grid									
Test Position	Height (cm)	% of Control Limit		Test Position	Height (cm)	% of Control Limit		IEEE Controlled Limit	IEEE Uncontrolled Limit
1	20	0.1%		6	120	0.4%		2.58	0.52
2	40	0.1%		7	140	1.1%			
3	60	0.1%		8	160	2.8%			
4	80	0.1%		9	180	4.0%			
5	100	0.1%		10	200	4.4%			
								RF Po (*Max)	36.0

BS-Position 2

Table 102

External Vehicle MPE Assessment @ 775.9125 MHz									
Antenna Location	Antenna Model	Gain (dBi)	Meas. Distance (cm)	E/H Field	Calibration Factor	Average over Body (mW/cm ²)	Initial Power (W)	Pwr. Density Calc. (mW/cm ²)	Pwr. Density Max Calc. (mW/cm ²)
Roof (cnt)	HAF4017A	5.15	60	E	0.77	0.037	36.1	0.019	0.02
Measurement Grid									
Test Position	Height (cm)	% of Control Limit		Test Position	Height (cm)	% of Control Limit		IEEE Controlled Limit	IEEE Uncontrolled Limit
1	20	0.0%		6	120	0.8%		2.59	0.52
2	40	0.1%		7	140	1.2%			
3	60	0.1%		8	160	3.4%			
4	80	0.1%		9	180	4.2%			
5	100	0.1%		10	200	4.4%			
								RF Po (*Max)	36.0

7/800MHz Mobile M20URS9PW1AN

BS-Position 2

Table 103

External Vehicle MPE Assessment @ 794.0875 MHz									
Antenna Location	Antenna Model	Gain (dBi)	Meas. Distance (cm)	E/H Field	Calibration Factor	Average over Body (mW/cm ²)	Initial Power (W)	Pwr. Density Calc. (mW/cm ²)	Pwr. Density Max Calc. (mW/cm ²)
Roof (cnt)	HAF4017A	5.15	60	E	0.76	0.053	37.0	0.026	0.03
Measurement Grid									
Test Position	Height (cm)	% of Control Limit			Test Position	Height (cm)	% of Control Limit		
1	20	0.0%			6	120	1.1%		
2	40	0.0%			7	140	2.6%		
3	60	0.1%			8	160	5.4%		
4	80	0.2%			9	180	5.1%		
5	100	0.9%			10	200	4.6%		
								IEEE Controlled Limit	IEEE Uncontrolled Limit
								2.65	0.53
								RF Po (*Max)	
								36.0	

BS-Position 2

Table 104

External Vehicle MPE Assessment @ 809.0125 MHz									
Antenna Location	Antenna Model	Gain (dBi)	Meas. Distance (cm)	E/H Field	Calibration Factor	Average over Body (mW/cm ²)	Initial Power (W)	Pwr. Density Calc. (mW/cm ²)	Pwr. Density Max Calc. (mW/cm ²)
Roof (cnt)	HAF4017A	5.15	60	E	0.75	0.075	41.3	0.037	0.04
Measurement Grid									
Test Position	Height (cm)	% of Control Limit			Test Position	Height (cm)	% of Control Limit		
1	20	0.0%			6	120	1.5%		
2	40	0.1%			7	140	3.7%		
3	60	0.3%			8	160	7.6%		
4	80	0.5%			9	180	7.7%		
5	100	0.7%			10	200	5.6%		
								IEEE Controlled Limit	IEEE Uncontrolled Limit
								2.70	0.54
								RF Po (*Max)	
								42.0	

BS-Position 2

Table 105

External Vehicle MPE Assessment @ 823.9875 MHz									
Antenna Location	Antenna Model	Gain (dBi)	Meas. Distance (cm)	E/H Field	Calibration Factor	Average over Body (mW/cm ²)	Initial Power (W)	Pwr. Density Calc. (mW/cm ²)	Pwr. Density Max Calc. (mW/cm ²)
Roof (cnt)	HAF4017A	5.15	60	E	0.74	0.075	41.6	0.038	0.04
Measurement Grid									
Test Position	Height (cm)	% of Control Limit			Test Position	Height (cm)	% of Control Limit		
1	20	0.0%			6	120	1.8%		
2	40	0.3%			7	140	5.4%		
3	60	0.5%			8	160	5.7%		
4	80	0.7%			9	180	6.6%		
5	100	0.9%			10	200	5.5%		
								IEEE Controlled Limit	IEEE Uncontrolled Limit
								2.75	0.55
								RF Po (*Max)	
								42.0	

7/800MHz Mobile M20URS9PW1AN

BS-Position 2

Table 106

External Vehicle MPE Assessment @ 851.0125 MHz									
Antenna Location	Antenna Model	Gain (dBi)	Meas. Distance (cm)	E/H Field	Calibration Factor	Average over Body (mW/cm ²)	Initial Power (W)	Pwr. Density Calc. (mW/cm ²)	Pwr. Density Max Calc. (mW/cm ²)
Roof (cnt)	HAF4017A	5.15	60	E	0.73	0.079	41.9	0.040	0.04
Measurement Grid									
Test Position	Height (cm)	% of Control Limit		Test Position	Height (cm)	% of Control Limit		IEEE Controlled Limit	IEEE Uncontrolled Limit
1	20	0.3%		6	120	3.4%		2.84	0.57
2	40	0.4%		7	140	5.0%			
3	60	0.5%		8	160	5.4%			
4	80	0.7%		9	180	5.5%			
5	100	1.5%		10	200	5.2%			
								RF Po (*Max)	
								42.0	

BS-Position 2

Table 107

External Vehicle MPE Assessment @ 859.0125 MHz									
Antenna Location	Antenna Model	Gain (dBi)	Meas. Distance (cm)	E/H Field	Calibration Factor	Average over Body (mW/cm ²)	Initial Power (W)	Pwr. Density Calc. (mW/cm ²)	Pwr. Density Max Calc. (mW/cm ²)
Roof (cnt)	HAF4017A	5.15	60	E	0.72	0.068	41.7	0.034	0.03
Measurement Grid									
Test Position	Height (cm)	% of Control Limit		Test Position	Height (cm)	% of Control Limit		IEEE Controlled Limit	IEEE Uncontrolled Limit
1	20	0.1%		6	120	2.7%		2.86	0.57
2	40	0.3%		7	140	4.7%			
3	60	0.4%		8	160	4.8%			
4	80	0.6%		9	180	4.7%			
5	100	1.0%		10	200	4.6%			
								RF Po (*Max)	
								42.0	

BS-Position 2

Table 108

External Vehicle MPE Assessment @ 868.9875 MHz									
Antenna Location	Antenna Model	Gain (dBi)	Meas. Distance (cm)	E/H Field	Calibration Factor	Average over Body (mW/cm ²)	Initial Power (W)	Pwr. Density Calc. (mW/cm ²)	Pwr. Density Max Calc. (mW/cm ²)
Roof (cnt)	HAF4017A	5.15	60	E	0.71	0.062	41.9	0.031	0.03
Measurement Grid									
Test Position	Height (cm)	% of Control Limit		Test Position	Height (cm)	% of Control Limit		IEEE Controlled Limit	IEEE Uncontrolled Limit
1	20	0.2%		6	120	2.7%		2.90	0.58
2	40	0.3%		7	140	4.0%			
3	60	0.4%		8	160	4.4%			
4	80	0.6%		9	180	4.6%			
5	100	1.1%		10	200	3.1%			
								RF Po (*Max)	
								42.0	

7/800MHz Mobile M20URS9PW1AN

BS-Position 3

Table 109

External Vehicle MPE Assessment @ 764.0875 MHz									
Antenna Location	Antenna Model	Gain (dBi)	Meas. Distance (cm)	E/H Field	Calibration Factor	Average over Body (mW/cm ²)	Initial Power (W)	Pwr. Density Calc. (mW/cm ²)	Pwr. Density Max Calc. (mW/cm ²)
Roof (cnt)	HAF4016A	2.15	60	E	0.78	0.016	36.0	0.008	0.01
Measurement Grid									
Test Position	Height (cm)	% of Control Limit		Test Position	Height (cm)	% of Control Limit		IEEE Controlled Limit	IEEE Uncontrolled Limit
1	20	0.0%		6	120	0.2%		2.55	0.51
2	40	0.0%		7	140	0.4%			
3	60	0.0%		8	160	1.0%			
4	80	0.0%		9	180	1.5%			
5	100	0.0%		10	200	3.1%			
								RF Po (*Max)	
								36.0	

BS-Position 3

Table 110

External Vehicle MPE Assessment @ 773.0125 MHz									
Antenna Location	Antenna Model	Gain (dBi)	Meas. Distance (cm)	E/H Field	Calibration Factor	Average over Body (mW/cm ²)	Initial Power (W)	Pwr. Density Calc. (mW/cm ²)	Pwr. Density Max Calc. (mW/cm ²)
Roof (cnt)	HAF4016A	2.15	60	E	0.78	0.022	36.0	0.011	0.01
Measurement Grid									
Test Position	Height (cm)	% of Control Limit		Test Position	Height (cm)	% of Control Limit		IEEE Controlled Limit	IEEE Uncontrolled Limit
1	20	0.0%		6	120	0.2%		2.58	0.52
2	40	0.0%		7	140	1.4%			
3	60	0.0%		8	160	2.2%			
4	80	0.2%		9	180	1.6%			
5	100	0.2%		10	200	2.8%			
								RF Po (*Max)	
								36.0	

BS-Position 3

Table 111

External Vehicle MPE Assessment @ 775.9125 MHz									
Antenna Location	Antenna Model	Gain (dBi)	Meas. Distance (cm)	E/H Field	Calibration Factor	Average over Body (mW/cm ²)	Initial Power (W)	Pwr. Density Calc. (mW/cm ²)	Pwr. Density Max Calc. (mW/cm ²)
Roof (cnt)	HAF4016A	2.15	60	E	0.77	0.020	36.1	0.010	0.01
Measurement Grid									
Test Position	Height (cm)	% of Control Limit		Test Position	Height (cm)	% of Control Limit		IEEE Controlled Limit	IEEE Uncontrolled Limit
1	20	0.1%		6	120	0.4%		2.59	0.52
2	40	0.0%		7	140	1.0%			
3	60	0.1%		8	160	1.6%			
4	80	0.1%		9	180	1.6%			
5	100	0.3%		10	200	2.5%			
								RF Po (*Max)	
								36.0	

7/800MHz Mobile M20URS9PW1AN

BS-Position 3

Table 112

External Vehicle MPE Assessment @ 794.0875 MHz									
Antenna Location	Antenna Model	Gain (dBi)	Meas. Distance (cm)	E/H Field	Calibration Factor	Average over Body (mW/cm ²)	Initial Power (W)	Pwr. Density Calc. (mW/cm ²)	Pwr. Density Max Calc. (mW/cm ²)
Roof (cnt)	HAF4016A	2.15	60	E	0.76	0.020	37.0	0.010	0.01
Measurement Grid									
Test Position	Height (cm)	% of Control Limit			Test Position	Height (cm)	% of Control Limit		
1	20	0.0%			6	120	0.2%		
2	40	0.0%			7	140	1.2%		
3	60	0.0%			8	160	1.6%		
4	80	0.1%			9	180	1.7%		
5	100	0.1%			10	200	2.5%		
								IEEE Controlled Limit	IEEE Uncontrolled Limit
								2.65	0.53
								RF Po (*Max)	
								36.0	

BS-Position 3

Table 113

External Vehicle MPE Assessment @ 809.0125 MHz									
Antenna Location	Antenna Model	Gain (dBi)	Meas. Distance (cm)	E/H Field	Calibration Factor	Average over Body (mW/cm ²)	Initial Power (W)	Pwr. Density Calc. (mW/cm ²)	Pwr. Density Max Calc. (mW/cm ²)
Roof (cnt)	HAF4016A	2.15	60	E	0.75	0.021	41.3	0.011	0.01
Measurement Grid									
Test Position	Height (cm)	% of Control Limit			Test Position	Height (cm)	% of Control Limit		
1	20	0.0%			6	120	0.5%		
2	40	0.0%			7	140	0.9%		
3	60	0.0%			8	160	1.4%		
4	80	0.0%			9	180	1.9%		
5	100	0.1%			10	200	3.0%		
								IEEE Controlled Limit	IEEE Uncontrolled Limit
								2.70	0.54
								RF Po (*Max)	
								42.0	

BS-Position 3

Table 114

External Vehicle MPE Assessment @ 823.9875 MHz									
Antenna Location	Antenna Model	Gain (dBi)	Meas. Distance (cm)	E/H Field	Calibration Factor	Average over Body (mW/cm ²)	Initial Power (W)	Pwr. Density Calc. (mW/cm ²)	Pwr. Density Max Calc. (mW/cm ²)
Roof (cnt)	HAF4016A	2.15	60	E	0.74	0.017	41.6	0.008	0.01
Measurement Grid									
Test Position	Height (cm)	% of Control Limit			Test Position	Height (cm)	% of Control Limit		
1	20	0.0%			6	120	0.3%		
2	40	0.0%			7	140	0.7%		
3	60	0.0%			8	160	0.8%		
4	80	0.0%			9	180	1.6%		
5	100	0.0%			10	200	2.7%		
								IEEE Controlled Limit	IEEE Uncontrolled Limit
								2.75	0.55
								RF Po (*Max)	
								42.0	

7/800MHz Mobile M20URS9PW1AN

BS-Position 3

Table 115

External Vehicle MPE Assessment @ 851.0125 MHz									
Antenna Location	Antenna Model	Gain (dBi)	Meas. Distance (cm)	E/H Field	Calibration Factor	Average over Body (mW/cm ²)	Initial Power (W)	Pwr. Density Calc. (mW/cm ²)	Pwr. Density Max Calc. (mW/cm ²)
Roof (cnt)	HAF4016A	2.15	60	E	0.73	0.021	41.9	0.011	0.01
Measurement Grid									
Test Position	Height (cm)	% of Control Limit			Test Position	Height (cm)	% of Control Limit		
1	20	0.0%			6	120	0.1%		
2	40	0.0%			7	140	0.8%		
3	60	0.0%			8	160	1.4%		
4	80	0.0%			9	180	2.1%		
5	100	0.1%			10	200	3.1%		
								IEEE Controlled Limit	IEEE Uncontrolled Limit
								2.84	0.57
								RF Po (*Max)	
								42.0	

BS-Position 3

Table 116

External Vehicle MPE Assessment @ 859.0125 MHz									
Antenna Location	Antenna Model	Gain (dBi)	Meas. Distance (cm)	E/H Field	Calibration Factor	Average over Body (mW/cm ²)	Initial Power (W)	Pwr. Density Calc. (mW/cm ²)	Pwr. Density Max Calc. (mW/cm ²)
Roof (cnt)	HAF4016A	2.15	60	E	0.72	0.018	41.7	0.009	0.01
Measurement Grid									
Test Position	Height (cm)	% of Control Limit			Test Position	Height (cm)	% of Control Limit		
1	20	0.0%			6	120	0.1%		
2	40	0.0%			7	140	0.5%		
3	60	0.0%			8	160	1.1%		
4	80	0.0%			9	180	1.6%		
5	100	0.0%			10	200	3.0%		
								IEEE Controlled Limit	IEEE Uncontrolled Limit
								2.86	0.57
								RF Po (*Max)	
								42.0	

BS-Position 3

Table 117

External Vehicle MPE Assessment @ 868.9875 MHz									
Antenna Location	Antenna Model	Gain (dBi)	Meas. Distance (cm)	E/H Field	Calibration Factor	Average over Body (mW/cm ²)	Initial Power (W)	Pwr. Density Calc. (mW/cm ²)	Pwr. Density Max Calc. (mW/cm ²)
Roof (cnt)	HAF4016A	2.15	60	E	0.71	0.025	41.9	0.012	0.01
Measurement Grid									
Test Position	Height (cm)	% of Control Limit			Test Position	Height (cm)	% of Control Limit		
1	20	0.0%			6	120	0.1%		
2	40	0.0%			7	140	1.1%		
3	60	0.0%			8	160	1.6%		
4	80	0.0%			9	180	2.5%		
5	100	0.1%			10	200	3.1%		
								IEEE Controlled Limit	IEEE Uncontrolled Limit
								2.90	0.58
								RF Po (*Max)	
								42.0	

7/800MHz Mobile M20URS9PW1AN

BS-Position 3

Table 118

External Vehicle MPE Assessment @ 764.0875 MHz									
Antenna Location	Antenna Model	Gain (dBi)	Meas. Distance (cm)	E/H Field	Calibration Factor	Average over Body (mW/cm ²)	Initial Power (W)	Pwr. Density Calc. (mW/cm ²)	Pwr. Density Max Calc. (mW/cm ²)
Roof (cnt)	HAF4014A	5.15	60	E	0.78	0.033	36.0	0.017	0.02
Measurement Grid									
Test Position	Height (cm)	% of Control Limit		Test Position	Height (cm)	% of Control Limit		IEEE Controlled Limit	IEEE Uncontrolled Limit
1	20	0.0%		6	120	1.5%		2.55	0.51
2	40	0.0%		7	140	1.6%			
3	60	0.3%		8	160	2.3%			
4	80	0.3%		9	180	2.4%			
5	100	0.8%		10	200	3.8%			
								RF Po (*Max)	36.0

BS-Position 3

Table 119

External Vehicle MPE Assessment @ 773.0125 MHz									
Antenna Location	Antenna Model	Gain (dBi)	Meas. Distance (cm)	E/H Field	Calibration Factor	Average over Body (mW/cm ²)	Initial Power (W)	Pwr. Density Calc. (mW/cm ²)	Pwr. Density Max Calc. (mW/cm ²)
Roof (cnt)	HAF4014A	5.15	60	E	0.78	0.038	36.0	0.019	0.02
Measurement Grid									
Test Position	Height (cm)	% of Control Limit		Test Position	Height (cm)	% of Control Limit		IEEE Controlled Limit	IEEE Uncontrolled Limit
1	20	0.0%		6	120	1.3%		2.58	0.52
2	40	0.0%		7	140	2.6%			
3	60	0.1%		8	160	3.0%			
4	80	0.8%		9	180	2.8%			
5	100	1.1%		10	200	3.2%			
								RF Po (*Max)	36.0

BS-Position 3

Table 120

External Vehicle MPE Assessment @ 775.9125 MHz									
Antenna Location	Antenna Model	Gain (dBi)	Meas. Distance (cm)	E/H Field	Calibration Factor	Average over Body (mW/cm ²)	Initial Power (W)	Pwr. Density Calc. (mW/cm ²)	Pwr. Density Max Calc. (mW/cm ²)
Roof (cnt)	HAF4014A	5.15	60	E	0.77	0.034	36.1	0.017	0.02
Measurement Grid									
Test Position	Height (cm)	% of Control Limit		Test Position	Height (cm)	% of Control Limit		IEEE Controlled Limit	IEEE Uncontrolled Limit
1	20	0.0%		6	120	1.2%		2.59	0.52
2	40	0.0%		7	140	1.8%			
3	60	0.1%		8	160	2.9%			
4	80	0.5%		9	180	2.0%			
5	100	1.0%		10	200	3.7%			
								RF Po (*Max)	36.0

7/800MHz Mobile M20URS9PW1AN

BS-Position 3

Table 121

External Vehicle MPE Assessment @ 794.0875 MHz									
Antenna Location	Antenna Model	Gain (dBi)	Meas. Distance (cm)	E/H Field	Calibration Factor	Average over Body (mW/cm ²)	Initial Power (W)	Pwr. Density Calc. (mW/cm ²)	Pwr. Density Max Calc. (mW/cm ²)
Roof (cnt)	HAF4014A	5.15	60	E	0.76	0.029	37.0	0.014	0.01
Measurement Grid									
Test Position	Height (cm)	% of Control Limit		Test Position	Height (cm)	% of Control Limit		IEEE Controlled Limit	IEEE Uncontrolled Limit
1	20	0.0%		6	120	0.8%		2.65	0.53
2	40	0.0%		7	140	1.4%			
3	60	0.0%		8	160	2.4%			
4	80	0.3%		9	180	2.4%			
5	100	0.5%		10	200	3.1%			RF Po (*Max)
									36.0

BS-Position 3

Table 122

External Vehicle MPE Assessment @ 809.0125 MHz									
Antenna Location	Antenna Model	Gain (dBi)	Meas. Distance (cm)	E/H Field	Calibration Factor	Average over Body (mW/cm ²)	Initial Power (W)	Pwr. Density Calc. (mW/cm ²)	Pwr. Density Max Calc. (mW/cm ²)
Roof (cnt)	HAF4014A	5.15	60	E	0.75	0.052	41.3	0.026	0.03
Measurement Grid									
Test Position	Height (cm)	% of Control Limit		Test Position	Height (cm)	% of Control Limit		IEEE Controlled Limit	IEEE Uncontrolled Limit
1	20	0.1%		6	120	2.0%		2.70	0.54
2	40	0.1%		7	140	4.3%			
3	60	0.1%		8	160	3.7%			
4	80	1.3%		9	180	2.4%			
5	100	1.5%		10	200	3.8%			RF Po (*Max)
									42.0

BS-Position 3

Table 123

External Vehicle MPE Assessment @ 823.9875 MHz									
Antenna Location	Antenna Model	Gain (dBi)	Meas. Distance (cm)	E/H Field	Calibration Factor	Average over Body (mW/cm ²)	Initial Power (W)	Pwr. Density Calc. (mW/cm ²)	Pwr. Density Max Calc. (mW/cm ²)
Roof (cnt)	HAF4014A	5.15	60	E	0.74	0.040	41.6	0.020	0.02
Measurement Grid									
Test Position	Height (cm)	% of Control Limit		Test Position	Height (cm)	% of Control Limit		IEEE Controlled Limit	IEEE Uncontrolled Limit
1	20	0.0%		6	120	1.4%		2.75	0.55
2	40	0.1%		7	140	2.9%			
3	60	0.3%		8	160	3.0%			
4	80	0.7%		9	180	2.0%			
5	100	1.1%		10	200	3.0%			RF Po (*Max)
									42.0

7/800MHz Mobile M20URS9PW1AN

BS-Position 3

Table 124

External Vehicle MPE Assessment @ 851.0125 MHz									
Antenna Location	Antenna Model	Gain (dBi)	Meas. Distance (cm)	E/H Field	Calibration Factor	Average over Body (mW/cm ²)	Initial Power (W)	Pwr. Density Calc. (mW/cm ²)	Pwr. Density Max Calc. (mW/cm ²)
Roof (cnt)	HAF4014A	5.15	60	E	0.73	0.043	41.9	0.022	0.02
Measurement Grid									
Test Position	Height (cm)	% of Control Limit			Test Position	Height (cm)	% of Control Limit		
1	20	0.1%			6	120	1.0%		
2	40	0.1%			7	140	2.3%		
3	60	0.3%			8	160	3.3%		
4	80	0.5%			9	180	2.8%		
5	100	1.0%			10	200	3.9%		
								IEEE Controlled Limit	IEEE Uncontrolled Limit
								2.84	0.57
								RF Po (*Max)	
								42.0	

BS-Position 3

Table 125

External Vehicle MPE Assessment @ 859.0125 MHz									
Antenna Location	Antenna Model	Gain (dBi)	Meas. Distance (cm)	E/H Field	Calibration Factor	Average over Body (mW/cm ²)	Initial Power (W)	Pwr. Density Calc. (mW/cm ²)	Pwr. Density Max Calc. (mW/cm ²)
Roof (cnt)	HAF4014A	5.15	60	E	0.72	0.038	41.7	0.019	0.02
Measurement Grid									
Test Position	Height (cm)	% of Control Limit			Test Position	Height (cm)	% of Control Limit		
1	20	0.0%			6	120	0.8%		
2	40	0.1%			7	140	2.2%		
3	60	0.1%			8	160	2.4%		
4	80	0.6%			9	180	2.7%		
5	100	0.6%			10	200	3.8%		
								IEEE Controlled Limit	IEEE Uncontrolled Limit
								2.86	0.57
								RF Po (*Max)	
								42.0	

BS-Position 3

Table 126

External Vehicle MPE Assessment @ 868.9875 MHz									
Antenna Location	Antenna Model	Gain (dBi)	Meas. Distance (cm)	E/H Field	Calibration Factor	Average over Body (mW/cm ²)	Initial Power (W)	Pwr. Density Calc. (mW/cm ²)	Pwr. Density Max Calc. (mW/cm ²)
Roof (cnt)	HAF4014A	5.15	60	E	0.71	0.037	41.9	0.019	0.02
Measurement Grid									
Test Position	Height (cm)	% of Control Limit			Test Position	Height (cm)	% of Control Limit		
1	20	0.0%			6	120	0.7%		
2	40	0.0%			7	140	1.7%		
3	60	0.2%			8	160	3.4%		
4	80	0.5%			9	180	3.0%		
5	100	0.6%			10	200	2.7%		
								IEEE Controlled Limit	IEEE Uncontrolled Limit
								2.90	0.58
								RF Po (*Max)	
								42.0	

7/800MHz Mobile M20URS9PW1AN

BS-Position 3

Table 127

External Vehicle MPE Assessment @ 764.0875 MHz									
Antenna Location	Antenna Model	Gain (dBi)	Meas. Distance (cm)	E/H Field	Calibration Factor	Average over Body (mW/cm ²)	Initial Power (W)	Pwr. Density Calc. (mW/cm ²)	Pwr. Density Max Calc. (mW/cm ²)
Roof (cnt)	HAF4013A	5.15	60	E	0.78	0.040	36.0	0.020	0.02
Measurement Grid									
Test Position	Height (cm)	% of Control Limit		Test Position	Height (cm)	% of Control Limit		IEEE Controlled Limit	IEEE Uncontrolled Limit
1	20	0.4%		6	120	1.2%		2.55	0.51
2	40	0.7%		7	140	1.8%			
3	60	0.8%		8	160	2.5%			
4	80	1.0%		9	180	2.5%			
5	100	1.1%		10	200	3.8%			
								RF Po (*Max)	36.0

BS-Position 3

Table 128

External Vehicle MPE Assessment @ 773.0125 MHz									
Antenna Location	Antenna Model	Gain (dBi)	Meas. Distance (cm)	E/H Field	Calibration Factor	Average over Body (mW/cm ²)	Initial Power (W)	Pwr. Density Calc. (mW/cm ²)	Pwr. Density Max Calc. (mW/cm ²)
Roof (cnt)	HAF4013A	5.15	60	E	0.78	0.037	36.0	0.018	0.02
Measurement Grid									
Test Position	Height (cm)	% of Control Limit		Test Position	Height (cm)	% of Control Limit		IEEE Controlled Limit	IEEE Uncontrolled Limit
1	20	0.6%		6	120	0.9%		2.58	0.52
2	40	0.8%		7	140	1.4%			
3	60	0.7%		8	160	2.1%			
4	80	0.7%		9	180	2.6%			
5	100	0.8%		10	200	3.7%			
								RF Po (*Max)	36.0

BS-Position 3

Table 129

External Vehicle MPE Assessment @ 775.9125 MHz									
Antenna Location	Antenna Model	Gain (dBi)	Meas. Distance (cm)	E/H Field	Calibration Factor	Average over Body (mW/cm ²)	Initial Power (W)	Pwr. Density Calc. (mW/cm ²)	Pwr. Density Max Calc. (mW/cm ²)
Roof (cnt)	HAF4013A	5.15	60	E	0.77	0.045	36.1	0.023	0.02
Measurement Grid									
Test Position	Height (cm)	% of Control Limit		Test Position	Height (cm)	% of Control Limit		IEEE Controlled Limit	IEEE Uncontrolled Limit
1	20	0.3%		6	120	1.6%		2.59	0.52
2	40	0.4%		7	140	1.7%			
3	60	0.8%		8	160	2.8%			
4	80	0.9%		9	180	3.0%			
5	100	1.0%		10	200	4.9%			
								RF Po (*Max)	36.0

7/800MHz Mobile M20URS9PW1AN

BS-Position 3

Table 130

External Vehicle MPE Assessment @ 794.0875 MHz										
Antenna Location	Antenna Model	Gain (dBi)	Meas. Distance (cm)	E/H Field	Calibration Factor	Average over Body (mW/cm ²)	Initial Power (W)	Pwr. Density Calc. (mW/cm ²)	Pwr. Density Max Calc. (mW/cm ²)	
Roof (cnt)	HAF4013A	5.15	60	E	0.76	0.035	37.0	0.017	0.02	
Measurement Grid										
Test Position	Height (cm)	% of Control Limit			Test Position	Height (cm)	% of Control Limit		IEEE Controlled Limit	IEEE Uncontrolled Limit
1	20	0.3%			6	120	1.1%		2.65	0.53
2	40	0.4%			7	140	1.8%			
3	60	0.4%			8	160	2.3%			
4	80	0.6%			9	180	2.3%			
5	100	0.7%			10	200	3.3%			RF Po (*Max)
									36.0	

BS-Position 3

Table 131

External Vehicle MPE Assessment @ 809.0125 MHz										
Antenna Location	Antenna Model	Gain (dBi)	Meas. Distance (cm)	E/H Field	Calibration Factor	Average over Body (mW/cm ²)	Initial Power (W)	Pwr. Density Calc. (mW/cm ²)	Pwr. Density Max Calc. (mW/cm ²)	
Roof (cnt)	HAF4013A	5.15	60	E	0.75	0.046	41.3	0.023	0.02	
Measurement Grid										
Test Position	Height (cm)	% of Control Limit			Test Position	Height (cm)	% of Control Limit		IEEE Controlled Limit	IEEE Uncontrolled Limit
1	20	0.6%			6	120	1.6%		2.70	0.54
2	40	0.7%			7	140	2.6%			
3	60	0.7%			8	160	2.7%			
4	80	0.8%			9	180	2.3%			
5	100	1.0%			10	200	4.0%			RF Po (*Max)
									42.0	

BS-Position 3

Table 132

External Vehicle MPE Assessment @ 823.9875 MHz										
Antenna Location	Antenna Model	Gain (dBi)	Meas. Distance (cm)	E/H Field	Calibration Factor	Average over Body (mW/cm ²)	Initial Power (W)	Pwr. Density Calc. (mW/cm ²)	Pwr. Density Max Calc. (mW/cm ²)	
Roof (cnt)	HAF4013A	5.15	60	E	0.74	0.036	41.6	0.018	0.02	
Measurement Grid										
Test Position	Height (cm)	% of Control Limit			Test Position	Height (cm)	% of Control Limit		IEEE Controlled Limit	IEEE Uncontrolled Limit
1	20	0.4%			6	120	1.3%		2.75	0.55
2	40	0.3%			7	140	1.6%			
3	60	0.3%			8	160	1.9%			
4	80	0.6%			9	180	2.6%			
5	100	1.2%			10	200	3.0%			RF Po (*Max)
									42.0	

7/800MHz Mobile M20URS9PW1AN

BS-Position 3

Table 133

External Vehicle MPE Assessment @ 851.0125 MHz									
Antenna Location	Antenna Model	Gain (dBi)	Meas. Distance (cm)	E/H Field	Calibration Factor	Average over Body (mW/cm ²)	Initial Power (W)	Pwr. Density Calc. (mW/cm ²)	Pwr. Density Max Calc. (mW/cm ²)
Roof (cnt)	HAF4013A	5.15	60	E	0.73	0.041	41.9	0.020	0.02
Measurement Grid									
Test Position	Height (cm)	% of Control Limit		Test Position	Height (cm)	% of Control Limit		IEEE Controlled Limit	IEEE Uncontrolled Limit
1	20	0.2%		6	120	1.2%		2.84	0.57
2	40	0.4%		7	140	1.5%			
3	60	0.9%		8	160	1.7%			
4	80	1.1%		9	180	2.4%			
5	100	1.2%		10	200	3.8%			
								RF Po (*Max)	
								42.0	

BS-Position 3

Table 134

External Vehicle MPE Assessment @ 859.0125 MHz									
Antenna Location	Antenna Model	Gain (dBi)	Meas. Distance (cm)	E/H Field	Calibration Factor	Average over Body (mW/cm ²)	Initial Power (W)	Pwr. Density Calc. (mW/cm ²)	Pwr. Density Max Calc. (mW/cm ²)
Roof (cnt)	HAF4013A	5.15	60	E	0.72	0.045	41.7	0.023	0.02
Measurement Grid									
Test Position	Height (cm)	% of Control Limit		Test Position	Height (cm)	% of Control Limit		IEEE Controlled Limit	IEEE Uncontrolled Limit
1	20	0.7%		6	120	1.1%		2.86	0.57
2	40	0.3%		7	140	2.1%			
3	60	0.5%		8	160	2.8%			
4	80	0.6%		9	180	2.9%			
5	100	1.0%		10	200	3.8%			
								RF Po (*Max)	
								42.0	

BS-Position 3

Table 135

External Vehicle MPE Assessment @ 868.9875 MHz									
Antenna Location	Antenna Model	Gain (dBi)	Meas. Distance (cm)	E/H Field	Calibration Factor	Average over Body (mW/cm ²)	Initial Power (W)	Pwr. Density Calc. (mW/cm ²)	Pwr. Density Max Calc. (mW/cm ²)
Roof (cnt)	HAF4013A	5.15	60	E	0.71	0.042	41.9	0.021	0.02
Measurement Grid									
Test Position	Height (cm)	% of Control Limit		Test Position	Height (cm)	% of Control Limit		IEEE Controlled Limit	IEEE Uncontrolled Limit
1	20	0.2%		6	120	0.8%		2.90	0.58
2	40	0.4%		7	140	1.8%			
3	60	1.0%		8	160	2.6%			
4	80	0.7%		9	180	2.6%			
5	100	0.8%		10	200	3.6%			
								RF Po (*Max)	
								42.0	

7/800MHz Mobile M20URS9PW1AN

BS-Position 3

Table 136

External Vehicle MPE Assessment @ 764.0875 MHz									
Antenna Location	Antenna Model	Gain (dBi)	Meas. Distance (cm)	E/H Field	Calibration Factor	Average over Body (mW/cm ²)	Initial Power (W)	Pwr. Density Calc. (mW/cm ²)	Pwr. Density Max Calc. (mW/cm ²)
Roof (cnt)	HAF4017A	5.15	60	E	0.78	0.024	36.0	0.012	0.01
Measurement Grid									
Test Position	Height (cm)	% of Control Limit			Test Position	Height (cm)	% of Control Limit		
1	20	0.5%			6	120	0.3%		
2	40	0.1%			7	140	0.9%		
3	60	0.3%			8	160	1.0%		
4	80	0.3%			9	180	2.3%		
5	100	0.3%			10	200	3.4%		
								IEEE Controlled Limit	IEEE Uncontrolled Limit
								2.55	0.51
								RF Po (*Max)	
								36.0	

BS-Position 3

Table 137

External Vehicle MPE Assessment @ 773.0125 MHz									
Antenna Location	Antenna Model	Gain (dBi)	Meas. Distance (cm)	E/H Field	Calibration Factor	Average over Body (mW/cm ²)	Initial Power (W)	Pwr. Density Calc. (mW/cm ²)	Pwr. Density Max Calc. (mW/cm ²)
Roof (cnt)	HAF4017A	5.15	60	E	0.78	0.027	36.0	0.014	0.01
Measurement Grid									
Test Position	Height (cm)	% of Control Limit			Test Position	Height (cm)	% of Control Limit		
1	20	0.4%			6	120	0.7%		
2	40	0.2%			7	140	1.1%		
3	60	0.3%			8	160	1.9%		
4	80	0.4%			9	180	1.8%		
5	100	0.5%			10	200	3.2%		
								IEEE Controlled Limit	IEEE Uncontrolled Limit
								2.58	0.52
								RF Po (*Max)	
								36.0	

BS-Position 3

Table 138

External Vehicle MPE Assessment @ 775.9125 MHz									
Antenna Location	Antenna Model	Gain (dBi)	Meas. Distance (cm)	E/H Field	Calibration Factor	Average over Body (mW/cm ²)	Initial Power (W)	Pwr. Density Calc. (mW/cm ²)	Pwr. Density Max Calc. (mW/cm ²)
Roof (cnt)	HAF4017A	5.15	60	E	0.77	0.028	36.1	0.014	0.01
Measurement Grid									
Test Position	Height (cm)	% of Control Limit			Test Position	Height (cm)	% of Control Limit		
1	20	0.2%			6	120	0.8%		
2	40	0.4%			7	140	1.0%		
3	60	0.4%			8	160	1.8%		
4	80	0.7%			9	180	2.0%		
5	100	0.7%			10	200	2.9%		
								IEEE Controlled Limit	IEEE Uncontrolled Limit
								2.59	0.52
								RF Po (*Max)	
								36.0	

7/800MHz Mobile M20URS9PW1AN

BS-Position 3

Table 139

External Vehicle MPE Assessment @ 794.0875 MHz									
Antenna Location	Antenna Model	Gain (dBi)	Meas. Distance (cm)	E/H Field	Calibration Factor	Average over Body (mW/cm ²)	Initial Power (W)	Pwr. Density Calc. (mW/cm ²)	Pwr. Density Max Calc. (mW/cm ²)
Roof (cnt)	HAF4017A	5.15	60	E	0.76	0.035	37.0	0.018	0.02
Measurement Grid									
Test Position	Height (cm)	% of Control Limit		Test Position	Height (cm)	% of Control Limit		IEEE Controlled Limit	IEEE Uncontrolled Limit
1	20	0.5%		6	120	1.3%		2.65	0.53
2	40	0.2%		7	140	1.4%			
3	60	0.5%		8	160	2.4%			
4	80	0.8%		9	180	2.1%			RF Po (*Max)
5	100	0.9%		10	200	3.3%			36.0

BS-Position 3

Table 140

External Vehicle MPE Assessment @ 809.0125 MHz									
Antenna Location	Antenna Model	Gain (dBi)	Meas. Distance (cm)	E/H Field	Calibration Factor	Average over Body (mW/cm ²)	Initial Power (W)	Pwr. Density Calc. (mW/cm ²)	Pwr. Density Max Calc. (mW/cm ²)
Roof (cnt)	HAF4017A	5.15	60	E	0.75	0.059	41.3	0.030	0.03
Measurement Grid									
Test Position	Height (cm)	% of Control Limit		Test Position	Height (cm)	% of Control Limit		IEEE Controlled Limit	IEEE Uncontrolled Limit
1	20	0.8%		6	120	2.0%		2.70	0.54
2	40	0.7%		7	140	3.1%			
3	60	0.7%		8	160	3.7%			
4	80	1.1%		9	180	3.9%			RF Po (*Max)
5	100	1.4%		10	200	4.6%			42.0

BS-Position 3

Table 141

External Vehicle MPE Assessment @ 823.9875 MHz									
Antenna Location	Antenna Model	Gain (dBi)	Meas. Distance (cm)	E/H Field	Calibration Factor	Average over Body (mW/cm ²)	Initial Power (W)	Pwr. Density Calc. (mW/cm ²)	Pwr. Density Max Calc. (mW/cm ²)
Roof (cnt)	HAF4017A	5.15	60	E	0.74	0.054	41.6	0.027	0.03
Measurement Grid									
Test Position	Height (cm)	% of Control Limit		Test Position	Height (cm)	% of Control Limit		IEEE Controlled Limit	IEEE Uncontrolled Limit
1	20	0.8%		6	120	2.2%		2.75	0.55
2	40	0.7%		7	140	3.4%			
3	60	0.7%		8	160	2.8%			
4	80	1.0%		9	180	3.0%			RF Po (*Max)
5	100	1.6%		10	200	3.4%			42.0

7/800MHz Mobile M20URS9PW1AN

BS-Position 3

Table 142

External Vehicle MPE Assessment @ 851.0125 MHz									
Antenna Location	Antenna Model	Gain (dBi)	Meas. Distance (cm)	E/H Field	Calibration Factor	Average over Body (mW/cm ²)	Initial Power (W)	Pwr. Density Calc. (mW/cm ²)	Pwr. Density Max Calc. (mW/cm ²)
Roof (cnt)	HAF4017A	5.15	60	E	0.73	0.068	41.9	0.034	0.03
Measurement Grid									
Test Position	Height (cm)	% of Control Limit		Test Position	Height (cm)	% of Control Limit		IEEE Controlled Limit	IEEE Uncontrolled Limit
1	20	0.8%		6	120	2.2%		2.84	0.57
2	40	1.0%		7	140	4.1%			
3	60	1.2%		8	160	4.8%			
4	80	1.5%		9	180	4.1%			
5	100	1.4%		10	200	2.9%			
								RF Po (*Max)	42.0

BS-Position 3

Table 143

External Vehicle MPE Assessment @ 859.0125 MHz									
Antenna Location	Antenna Model	Gain (dBi)	Meas. Distance (cm)	E/H Field	Calibration Factor	Average over Body (mW/cm ²)	Initial Power (W)	Pwr. Density Calc. (mW/cm ²)	Pwr. Density Max Calc. (mW/cm ²)
Roof (cnt)	HAF4017A	5.15	60	E	0.72	0.058	41.7	0.029	0.03
Measurement Grid									
Test Position	Height (cm)	% of Control Limit		Test Position	Height (cm)	% of Control Limit		IEEE Controlled Limit	IEEE Uncontrolled Limit
1	20	0.9%		6	120	1.8%		2.86	0.57
2	40	0.8%		7	140	2.5%			
3	60	1.3%		8	160	3.7%			
4	80	1.2%		9	180	3.7%			
5	100	1.6%		10	200	2.9%			
								RF Po (*Max)	42.0

BS-Position 3

Table 144

External Vehicle MPE Assessment @ 868.9875 MHz									
Antenna Location	Antenna Model	Gain (dBi)	Meas. Distance (cm)	E/H Field	Calibration Factor	Average over Body (mW/cm ²)	Initial Power (W)	Pwr. Density Calc. (mW/cm ²)	Pwr. Density Max Calc. (mW/cm ²)
Roof (cnt)	HAF4017A	5.15	60	E	0.71	0.054	41.9	0.027	0.03
Measurement Grid									
Test Position	Height (cm)	% of Control Limit		Test Position	Height (cm)	% of Control Limit		IEEE Controlled Limit	IEEE Uncontrolled Limit
1	20	0.4%		6	120	1.7%		2.90	0.58
2	40	0.5%		7	140	3.3%			
3	60	0.8%		8	160	3.9%			
4	80	1.0%		9	180	3.2%			
5	100	1.1%		10	200	2.9%			
								RF Po (*Max)	42.0

7/800MHz Mobile M20URS9PW1AN

BS-Position 4

Table 145

External Vehicle MPE Assessment @ 764.0875 MHz									
Antenna Location	Antenna Model	Gain (dBi)	Meas. Distance (cm)	E/H Field	Calibration Factor	Average over Body (mW/cm ²)	Initial Power (W)	Pwr. Density Calc. (mW/cm ²)	Pwr. Density Max Calc. (mW/cm ²)
Roof (cnt)	HAF4016A	2.15	60	E	0.78	0.032	36.0	0.016	0.02
Measurement Grid									
Test Position	Height (cm)	% of Control Limit			Test Position	Height (cm)	% of Control Limit		
1	20	1.5%			6	120	0.7%		
2	40	0.4%			7	140	1.2%		
3	60	0.3%			8	160	2.1%		
4	80	0.8%			9	180	2.4%		
5	100	0.6%			10	200	2.6%		
								IEEE Controlled Limit	IEEE Uncontrolled Limit
								2.55	0.51
								RF Po (*Max)	
								36.0	

BS-Position 4

Table 146

External Vehicle MPE Assessment @ 773.0125 MHz									
Antenna Location	Antenna Model	Gain (dBi)	Meas. Distance (cm)	E/H Field	Calibration Factor	Average over Body (mW/cm ²)	Initial Power (W)	Pwr. Density Calc. (mW/cm ²)	Pwr. Density Max Calc. (mW/cm ²)
Roof (cnt)	HAF4016A	2.15	60	E	0.78	0.039	36.0	0.019	0.02
Measurement Grid									
Test Position	Height (cm)	% of Control Limit			Test Position	Height (cm)	% of Control Limit		
1	20	1.6%			6	120	1.0%		
2	40	0.4%			7	140	1.1%		
3	60	1.1%			8	160	2.4%		
4	80	1.1%			9	180	2.6%		
5	100	1.0%			10	200	2.8%		
								IEEE Controlled Limit	IEEE Uncontrolled Limit
								2.58	0.52
								RF Po (*Max)	
								36.0	

BS-Position 4

Table 147

External Vehicle MPE Assessment @ 775.9125 MHz									
Antenna Location	Antenna Model	Gain (dBi)	Meas. Distance (cm)	E/H Field	Calibration Factor	Average over Body (mW/cm ²)	Initial Power (W)	Pwr. Density Calc. (mW/cm ²)	Pwr. Density Max Calc. (mW/cm ²)
Roof (cnt)	HAF4016A	2.15	60	E	0.77	0.034	36.1	0.017	0.02
Measurement Grid									
Test Position	Height (cm)	% of Control Limit			Test Position	Height (cm)	% of Control Limit		
1	20	0.8%			6	120	1.1%		
2	40	0.3%			7	140	1.1%		
3	60	0.4%			8	160	2.2%		
4	80	0.7%			9	180	3.2%		
5	100	0.9%			10	200	2.5%		
								IEEE Controlled Limit	IEEE Uncontrolled Limit
								2.59	0.52
								RF Po (*Max)	
								36.0	

7/800MHz Mobile M20URS9PW1AN

BS-Position 4

Table 148

External Vehicle MPE Assessment @ 794.0875 MHz									
Antenna Location	Antenna Model	Gain (dBi)	Meas. Distance (cm)	E/H Field	Calibration Factor	Average over Body (mW/cm ²)	Initial Power (W)	Pwr. Density Calc. (mW/cm ²)	Pwr. Density Max Calc. (mW/cm ²)
Roof (cnt)	HAF4016A	2.15	60	E	0.76	0.029	37.0	0.015	0.01
Measurement Grid									
Test Position	Height (cm)	% of Control Limit			Test Position	Height (cm)	% of Control Limit		
1	20	0.1%			6	120	1.3%		
2	40	0.2%			7	140	1.0%		
3	60	0.8%			8	160	1.6%		
4	80	0.7%			9	180	2.2%		
5	100	1.0%			10	200	2.1%		
								IEEE Controlled Limit	IEEE Uncontrolled Limit
								2.65	0.53
								RF Po (*Max)	
								36.0	

BS-Position 4

Table 149

External Vehicle MPE Assessment @ 809.0125 MHz									
Antenna Location	Antenna Model	Gain (dBi)	Meas. Distance (cm)	E/H Field	Calibration Factor	Average over Body (mW/cm ²)	Initial Power (W)	Pwr. Density Calc. (mW/cm ²)	Pwr. Density Max Calc. (mW/cm ²)
Roof (cnt)	HAF4016A	2.15	60	E	0.75	0.036	41.3	0.018	0.02
Measurement Grid									
Test Position	Height (cm)	% of Control Limit			Test Position	Height (cm)	% of Control Limit		
1	20	0.3%			6	120	1.4%		
2	40	0.3%			7	140	1.3%		
3	60	0.4%			8	160	1.5%		
4	80	0.9%			9	180	2.9%		
5	100	1.0%			10	200	3.2%		
								IEEE Controlled Limit	IEEE Uncontrolled Limit
								2.70	0.54
								RF Po (*Max)	
								42.0	

BS-Position 4

Table 150

External Vehicle MPE Assessment @ 823.9875 MHz									
Antenna Location	Antenna Model	Gain (dBi)	Meas. Distance (cm)	E/H Field	Calibration Factor	Average over Body (mW/cm ²)	Initial Power (W)	Pwr. Density Calc. (mW/cm ²)	Pwr. Density Max Calc. (mW/cm ²)
Roof (cnt)	HAF4016A	2.15	60	E	0.74	0.035	41.6	0.018	0.02
Measurement Grid									
Test Position	Height (cm)	% of Control Limit			Test Position	Height (cm)	% of Control Limit		
1	20	0.7%			6	120	1.2%		
2	40	0.6%			7	140	1.3%		
3	60	0.6%			8	160	1.7%		
4	80	0.8%			9	180	2.1%		
5	100	1.2%			10	200	2.7%		
								IEEE Controlled Limit	IEEE Uncontrolled Limit
								2.75	0.55
								RF Po (*Max)	
								42.0	

7/800MHz Mobile M20URS9PW1AN

BS-Position 4

Table 151

External Vehicle MPE Assessment @ 851.0125 MHz									
Antenna Location	Antenna Model	Gain (dBi)	Meas. Distance (cm)	E/H Field	Calibration Factor	Average over Body (mW/cm ²)	Initial Power (W)	Pwr. Density Calc. (mW/cm ²)	Pwr. Density Max Calc. (mW/cm ²)
Roof (cnt)	HAF4016A	2.15	60	E	0.73	0.037	41.9	0.019	0.02
Measurement Grid									
Test Position	Height (cm)	% of Control Limit			Test Position	Height (cm)	% of Control Limit		
1	20	0.9%			6	120	1.4%		
2	40	0.5%			7	140	1.3%		
3	60	0.5%			8	160	2.0%		
4	80	1.1%			9	180	2.0%		
5	100	1.0%			10	200	2.4%		
								IEEE Controlled Limit	IEEE Uncontrolled Limit
								2.84	0.57
								RF Po (*Max)	
								42.0	

BS-Position 4

Table 152

External Vehicle MPE Assessment @ 859.0125 MHz									
Antenna Location	Antenna Model	Gain (dBi)	Meas. Distance (cm)	E/H Field	Calibration Factor	Average over Body (mW/cm ²)	Initial Power (W)	Pwr. Density Calc. (mW/cm ²)	Pwr. Density Max Calc. (mW/cm ²)
Roof (cnt)	HAF4016A	2.15	60	E	0.72	0.037	41.7	0.018	0.02
Measurement Grid									
Test Position	Height (cm)	% of Control Limit			Test Position	Height (cm)	% of Control Limit		
1	20	0.8%			6	120	1.0%		
2	40	0.6%			7	140	1.3%		
3	60	0.6%			8	160	1.4%		
4	80	0.9%			9	180	2.3%		
5	100	1.0%			10	200	3.0%		
								IEEE Controlled Limit	IEEE Uncontrolled Limit
								2.86	0.57
								RF Po (*Max)	
								42.0	

BS-Position 4

Table 153

External Vehicle MPE Assessment @ 868.9875 MHz									
Antenna Location	Antenna Model	Gain (dBi)	Meas. Distance (cm)	E/H Field	Calibration Factor	Average over Body (mW/cm ²)	Initial Power (W)	Pwr. Density Calc. (mW/cm ²)	Pwr. Density Max Calc. (mW/cm ²)
Roof (cnt)	HAF4016A	2.15	60	E	0.71	0.039	41.9	0.019	0.02
Measurement Grid									
Test Position	Height (cm)	% of Control Limit			Test Position	Height (cm)	% of Control Limit		
1	20	0.8%			6	120	1.0%		
2	40	0.3%			7	140	1.2%		
3	60	0.8%			8	160	1.9%		
4	80	1.0%			9	180	2.3%		
5	100	1.1%			10	200	3.0%		
								IEEE Controlled Limit	IEEE Uncontrolled Limit
								2.90	0.58
								RF Po (*Max)	
								42.0	

7/800MHz Mobile M20URS9PW1AN

BS-Position 4

Table 154

External Vehicle MPE Assessment @ 764.0875 MHz									
Antenna Location	Antenna Model	Gain (dBi)	Meas. Distance (cm)	E/H Field	Calibration Factor	Average over Body (mW/cm ²)	Initial Power (W)	Pwr. Density Calc. (mW/cm ²)	Pwr. Density Max Calc. (mW/cm ²)
Roof (cnt)	HAF4014A	5.15	60	E	0.78	0.051	36.0	0.026	0.03
Measurement Grid									
Test Position	Height (cm)	% of Control Limit		Test Position	Height (cm)	% of Control Limit		IEEE Controlled Limit	IEEE Uncontrolled Limit
1	20	0.9%		6	120	1.6%		2.55	0.51
2	40	0.8%		7	140	2.2%			
3	60	0.7%		8	160	3.9%			
4	80	1.4%		9	180	4.2%			
5	100	1.5%		10	200	2.9%			
								RF Po (*Max)	36.0

BS-Position 4

Table 155

External Vehicle MPE Assessment @ 773.0125 MHz									
Antenna Location	Antenna Model	Gain (dBi)	Meas. Distance (cm)	E/H Field	Calibration Factor	Average over Body (mW/cm ²)	Initial Power (W)	Pwr. Density Calc. (mW/cm ²)	Pwr. Density Max Calc. (mW/cm ²)
Roof (cnt)	HAF4014A	5.15	60	E	0.78	0.056	36.0	0.028	0.03
Measurement Grid									
Test Position	Height (cm)	% of Control Limit		Test Position	Height (cm)	% of Control Limit		IEEE Controlled Limit	IEEE Uncontrolled Limit
1	20	1.1%		6	120	2.3%		2.58	0.52
2	40	0.6%		7	140	2.6%			
3	60	1.0%		8	160	3.4%			
4	80	1.6%		9	180	4.1%			
5	100	1.9%		10	200	3.2%			
								RF Po (*Max)	36.0

BS-Position 4

Table 156

External Vehicle MPE Assessment @ 775.9125 MHz									
Antenna Location	Antenna Model	Gain (dBi)	Meas. Distance (cm)	E/H Field	Calibration Factor	Average over Body (mW/cm ²)	Initial Power (W)	Pwr. Density Calc. (mW/cm ²)	Pwr. Density Max Calc. (mW/cm ²)
Roof (cnt)	HAF4014A	5.15	60	E	0.77	0.054	36.1	0.027	0.03
Measurement Grid									
Test Position	Height (cm)	% of Control Limit		Test Position	Height (cm)	% of Control Limit		IEEE Controlled Limit	IEEE Uncontrolled Limit
1	20	1.1%		6	120	2.1%		2.59	0.52
2	40	0.9%		7	140	2.5%			
3	60	1.1%		8	160	2.6%			
4	80	1.4%		9	180	3.8%			
5	100	1.9%		10	200	3.3%			
								RF Po (*Max)	36.0

7/800MHz Mobile M20URS9PW1AN

BS-Position 4

Table 157

External Vehicle MPE Assessment @ 794.0875 MHz										
Antenna Location	Antenna Model	Gain (dBi)	Meas. Distance (cm)	E/H Field	Calibration Factor	Average over Body (mW/cm ²)	Initial Power (W)	Pwr. Density Calc. (mW/cm ²)	Pwr. Density Max Calc. (mW/cm ²)	
Roof (cnt)	HAF4014A	5.15	60	E	0.76	0.047	37.0	0.024	0.02	
Measurement Grid										
Test Position	Height (cm)	% of Control Limit			Test Position	Height (cm)	% of Control Limit		IEEE Controlled Limit	IEEE Uncontrolled Limit
1	20	0.9%			6	120	2.0%		2.65	0.53
2	40	0.8%			7	140	2.2%			
3	60	0.9%			8	160	2.6%			
4	80	1.2%			9	180	2.9%			
5	100	1.7%			10	200	2.6%			
								RF Po (*Max)		36.0

BS-Position 4

Table 158

External Vehicle MPE Assessment @ 809.0125 MHz										
Antenna Location	Antenna Model	Gain (dBi)	Meas. Distance (cm)	E/H Field	Calibration Factor	Average over Body (mW/cm ²)	Initial Power (W)	Pwr. Density Calc. (mW/cm ²)	Pwr. Density Max Calc. (mW/cm ²)	
Roof (cnt)	HAF4014A	5.15	60	E	0.75	0.057	41.3	0.029	0.03	
Measurement Grid										
Test Position	Height (cm)	% of Control Limit			Test Position	Height (cm)	% of Control Limit		IEEE Controlled Limit	IEEE Uncontrolled Limit
1	20	0.9%			6	120	2.0%		2.70	0.54
2	40	1.2%			7	140	2.1%			
3	60	1.2%			8	160	3.4%			
4	80	1.3%			9	180	3.7%			
5	100	2.1%			10	200	3.3%			
								RF Po (*Max)		42.0

BS-Position 4

Table 159

External Vehicle MPE Assessment @ 823.9875 MHz										
Antenna Location	Antenna Model	Gain (dBi)	Meas. Distance (cm)	E/H Field	Calibration Factor	Average over Body (mW/cm ²)	Initial Power (W)	Pwr. Density Calc. (mW/cm ²)	Pwr. Density Max Calc. (mW/cm ²)	
Roof (cnt)	HAF4014A	5.15	60	E	0.74	0.053	41.6	0.027	0.03	
Measurement Grid										
Test Position	Height (cm)	% of Control Limit			Test Position	Height (cm)	% of Control Limit		IEEE Controlled Limit	IEEE Uncontrolled Limit
1	20	0.5%			6	120	2.2%		2.75	0.55
2	40	0.4%			7	140	2.6%			
3	60	0.4%			8	160	2.8%			
4	80	1.4%			9	180	3.5%			
5	100	2.0%			10	200	3.5%			
								RF Po (*Max)		42.0

7/800MHz Mobile M20URS9PW1AN

BS-Position 4

Table 160

External Vehicle MPE Assessment @ 851.0125 MHz									
Antenna Location	Antenna Model	Gain (dBi)	Meas. Distance (cm)	E/H Field	Calibration Factor	Average over Body (mW/cm ²)	Initial Power (W)	Pwr. Density Calc. (mW/cm ²)	Pwr. Density Max Calc. (mW/cm ²)
Roof (cnt)	HAF4014A	5.15	60	E	0.73	0.044	41.9	0.022	0.02
Measurement Grid									
Test Position	Height (cm)	% of Control Limit			Test Position	Height (cm)	% of Control Limit		
1	20	1.0%			6	120	1.3%		
2	40	0.3%			7	140	1.7%		
3	60	0.4%			8	160	2.8%		
4	80	0.8%			9	180	2.9%		
5	100	1.0%			10	200	3.4%		
								IEEE Controlled Limit	IEEE Uncontrolled Limit
								2.84	0.57
								RF Po (*Max)	
								42.0	

BS-Position 4

Table 161

External Vehicle MPE Assessment @ 859.0125 MHz									
Antenna Location	Antenna Model	Gain (dBi)	Meas. Distance (cm)	E/H Field	Calibration Factor	Average over Body (mW/cm ²)	Initial Power (W)	Pwr. Density Calc. (mW/cm ²)	Pwr. Density Max Calc. (mW/cm ²)
Roof (cnt)	HAF4014A	5.15	60	E	0.72	0.040	41.7	0.020	0.02
Measurement Grid									
Test Position	Height (cm)	% of Control Limit			Test Position	Height (cm)	% of Control Limit		
1	20	0.6%			6	120	1.4%		
2	40	0.3%			7	140	1.7%		
3	60	0.5%			8	160	2.1%		
4	80	0.8%			9	180	2.5%		
5	100	1.2%			10	200	2.9%		
								IEEE Controlled Limit	IEEE Uncontrolled Limit
								2.86	0.57
								RF Po (*Max)	
								42.0	

BS-Position 4

Table 162

External Vehicle MPE Assessment @ 868.9875 MHz									
Antenna Location	Antenna Model	Gain (dBi)	Meas. Distance (cm)	E/H Field	Calibration Factor	Average over Body (mW/cm ²)	Initial Power (W)	Pwr. Density Calc. (mW/cm ²)	Pwr. Density Max Calc. (mW/cm ²)
Roof (cnt)	HAF4014A	5.15	60	E	0.71	0.040	41.9	0.020	0.02
Measurement Grid									
Test Position	Height (cm)	% of Control Limit			Test Position	Height (cm)	% of Control Limit		
1	20	0.5%			6	120	1.4%		
2	40	0.3%			7	140	1.6%		
3	60	0.4%			8	160	2.4%		
4	80	1.1%			9	180	2.5%		
5	100	1.3%			10	200	2.4%		
								IEEE Controlled Limit	IEEE Uncontrolled Limit
								2.90	0.58
								RF Po (*Max)	
								42.0	

7/800MHz Mobile M20URS9PW1AN

BS-Position 4

Table 163

External Vehicle MPE Assessment @ 764.0875 MHz									
Antenna Location	Antenna Model	Gain (dBi)	Meas. Distance (cm)	E/H Field	Calibration Factor	Average over Body (mW/cm ²)	Initial Power (W)	Pwr. Density Calc. (mW/cm ²)	Pwr. Density Max Calc. (mW/cm ²)
Roof (cnt)	HAF4013A	5.15	60	E	0.78	0.039	36.0	0.019	0.02
Measurement Grid									
Test Position	Height (cm)	% of Control Limit			Test Position	Height (cm)	% of Control Limit		
1	20	0.8%			6	120	1.2%		
2	40	0.3%			7	140	1.6%		
3	60	0.6%			8	160	2.6%		
4	80	0.9%			9	180	3.2%		
5	100	0.9%			10	200	3.1%		
								IEEE Controlled Limit	IEEE Uncontrolled Limit
								2.55	0.51
								RF Po (*Max)	
								36.0	

BS-Position 4

Table 164

External Vehicle MPE Assessment @ 773.0125 MHz									
Antenna Location	Antenna Model	Gain (dBi)	Meas. Distance (cm)	E/H Field	Calibration Factor	Average over Body (mW/cm ²)	Initial Power (W)	Pwr. Density Calc. (mW/cm ²)	Pwr. Density Max Calc. (mW/cm ²)
Roof (cnt)	HAF4013A	5.15	60	E	0.78	0.035	36.0	0.018	0.02
Measurement Grid									
Test Position	Height (cm)	% of Control Limit			Test Position	Height (cm)	% of Control Limit		
1	20	0.8%			6	120	1.3%		
2	40	0.3%			7	140	1.4%		
3	60	0.3%			8	160	1.8%		
4	80	1.0%			9	180	2.5%		
5	100	1.1%			10	200	3.1%		
								IEEE Controlled Limit	IEEE Uncontrolled Limit
								2.58	0.52
								RF Po (*Max)	
								36.0	

BS-Position 4

Table 165

External Vehicle MPE Assessment @ 775.9125 MHz									
Antenna Location	Antenna Model	Gain (dBi)	Meas. Distance (cm)	E/H Field	Calibration Factor	Average over Body (mW/cm ²)	Initial Power (W)	Pwr. Density Calc. (mW/cm ²)	Pwr. Density Max Calc. (mW/cm ²)
Roof (cnt)	HAF4013A	5.15	60	E	0.77	0.043	36.1	0.022	0.02
Measurement Grid									
Test Position	Height (cm)	% of Control Limit			Test Position	Height (cm)	% of Control Limit		
1	20	0.9%			6	120	1.8%		
2	40	0.4%			7	140	1.8%		
3	60	0.6%			8	160	2.4%		
4	80	0.9%			9	180	2.9%		
5	100	1.2%			10	200	3.9%		
								IEEE Controlled Limit	IEEE Uncontrolled Limit
								2.59	0.52
								RF Po (*Max)	
								36.0	

7/800MHz Mobile M20URS9PW1AN

BS-Position 4

Table 166

External Vehicle MPE Assessment @ 794.0875 MHz									
Antenna Location	Antenna Model	Gain (dBi)	Meas. Distance (cm)	E/H Field	Calibration Factor	Average over Body (mW/cm ²)	Initial Power (W)	Pwr. Density Calc. (mW/cm ²)	Pwr. Density Max Calc. (mW/cm ²)
Roof (cnt)	HAF4013A	5.15	60	E	0.76	0.039	37.0	0.019	0.02
Measurement Grid									
Test Position	Height (cm)	% of Control Limit		Test Position	Height (cm)	% of Control Limit		IEEE Controlled Limit	IEEE Uncontrolled Limit
1	20	0.4%		6	120	1.4%		2.65	0.53
2	40	0.6%		7	140	1.6%			
3	60	0.7%		8	160	1.7%			
4	80	0.6%		9	180	2.4%			
5	100	1.2%		10	200	4.0%			
								RF Po (*Max)	
								36.0	

BS-Position 4

Table 167

External Vehicle MPE Assessment @ 809.0125 MHz									
Antenna Location	Antenna Model	Gain (dBi)	Meas. Distance (cm)	E/H Field	Calibration Factor	Average over Body (mW/cm ²)	Initial Power (W)	Pwr. Density Calc. (mW/cm ²)	Pwr. Density Max Calc. (mW/cm ²)
Roof (cnt)	HAF4013A	5.15	60	E	0.75	0.034	41.3	0.017	0.02
Measurement Grid									
Test Position	Height (cm)	% of Control Limit		Test Position	Height (cm)	% of Control Limit		IEEE Controlled Limit	IEEE Uncontrolled Limit
1	20	0.4%		6	120	1.1%		2.70	0.54
2	40	0.3%		7	140	1.1%			
3	60	0.6%		8	160	1.4%			
4	80	1.0%		9	180	2.6%			
5	100	1.0%		10	200	3.2%			
								RF Po (*Max)	
								42.0	

BS-Position 4

Table 168

External Vehicle MPE Assessment @ 823.9875 MHz									
Antenna Location	Antenna Model	Gain (dBi)	Meas. Distance (cm)	E/H Field	Calibration Factor	Average over Body (mW/cm ²)	Initial Power (W)	Pwr. Density Calc. (mW/cm ²)	Pwr. Density Max Calc. (mW/cm ²)
Roof (cnt)	HAF4013A	5.15	60	E	0.74	0.039	41.6	0.019	0.02
Measurement Grid									
Test Position	Height (cm)	% of Control Limit		Test Position	Height (cm)	% of Control Limit		IEEE Controlled Limit	IEEE Uncontrolled Limit
1	20	0.9%		6	120	1.4%		2.75	0.55
2	40	0.2%		7	140	1.4%			
3	60	0.5%		8	160	1.9%			
4	80	0.8%		9	180	2.8%			
5	100	1.2%		10	200	3.0%			
								RF Po (*Max)	
								42.0	

7/800MHz Mobile M20URS9PW1AN

BS-Position 4

Table 169

External Vehicle MPE Assessment @ 851.0125 MHz									
Antenna Location	Antenna Model	Gain (dBi)	Meas. Distance (cm)	E/H Field	Calibration Factor	Average over Body (mW/cm ²)	Initial Power (W)	Pwr. Density Calc. (mW/cm ²)	Pwr. Density Max Calc. (mW/cm ²)
Roof (cnt)	HAF4013A	5.15	60	E	0.73	0.038	41.9	0.019	0.02
Measurement Grid									
Test Position	Height (cm)	% of Control Limit			Test Position	Height (cm)	% of Control Limit		
1	20	0.7%			6	120	1.3%		
2	40	0.3%			7	140	1.3%		
3	60	0.5%			8	160	1.6%		
4	80	0.6%			9	180	2.5%		
5	100	1.2%			10	200	3.5%		
								IEEE Controlled Limit	IEEE Uncontrolled Limit
								2.84	0.57
								RF Po (*Max)	
								42.0	

BS-Position 4

Table 170

External Vehicle MPE Assessment @ 859.0125 MHz									
Antenna Location	Antenna Model	Gain (dBi)	Meas. Distance (cm)	E/H Field	Calibration Factor	Average over Body (mW/cm ²)	Initial Power (W)	Pwr. Density Calc. (mW/cm ²)	Pwr. Density Max Calc. (mW/cm ²)
Roof (cnt)	HAF4013A	5.15	60	E	0.72	0.042	41.7	0.021	0.02
Measurement Grid									
Test Position	Height (cm)	% of Control Limit			Test Position	Height (cm)	% of Control Limit		
1	20	0.8%			6	120	1.5%		
2	40	0.5%			7	140	1.5%		
3	60	0.6%			8	160	1.7%		
4	80	1.0%			9	180	2.2%		
5	100	1.1%			10	200	3.6%		
								IEEE Controlled Limit	IEEE Uncontrolled Limit
								2.86	0.57
								RF Po (*Max)	
								42.0	

BS-Position 4

Table 171

External Vehicle MPE Assessment @ 868.9875 MHz									
Antenna Location	Antenna Model	Gain (dBi)	Meas. Distance (cm)	E/H Field	Calibration Factor	Average over Body (mW/cm ²)	Initial Power (W)	Pwr. Density Calc. (mW/cm ²)	Pwr. Density Max Calc. (mW/cm ²)
Roof (cnt)	HAF4013A	5.15	60	E	0.71	0.039	41.9	0.019	0.02
Measurement Grid									
Test Position	Height (cm)	% of Control Limit			Test Position	Height (cm)	% of Control Limit		
1	20	0.7%			6	120	1.0%		
2	40	0.7%			7	140	1.1%		
3	60	0.6%			8	160	1.8%		
4	80	0.9%			9	180	2.3%		
5	100	0.9%			10	200	3.3%		
								IEEE Controlled Limit	IEEE Uncontrolled Limit
								2.90	0.58
								RF Po (*Max)	
								42.0	

7/800MHz Mobile M20URS9PW1AN

BS-Position 4

Table 172

External Vehicle MPE Assessment @ 764.0875 MHz										
Antenna Location	Antenna Model	Gain (dBi)	Meas. Distance (cm)	E/H Field	Calibration Factor	Average over Body (mW/cm ²)	Initial Power (W)	Pwr. Density Calc. (mW/cm ²)	Pwr. Density Max Calc. (mW/cm ²)	
Roof (cnt)	HAF4017A	5.15	60	E	0.78	0.027	36.0	0.013	0.01	
Measurement Grid										
Test Position	Height (cm)	% of Control Limit			Test Position	Height (cm)	% of Control Limit		IEEE Controlled Limit	IEEE Uncontrolled Limit
1	20	0.9%			6	120	0.8%		2.55	0.51
2	40	0.2%			7	140	1.0%			
3	60	0.3%			8	160	1.2%			
4	80	0.3%			9	180	2.4%			
5	100	0.3%			10	200	3.2%			
									RF Po (*Max)	36.0

BS-Position 4

Table 173

External Vehicle MPE Assessment @ 773.0125 MHz										
Antenna Location	Antenna Model	Gain (dBi)	Meas. Distance (cm)	E/H Field	Calibration Factor	Average over Body (mW/cm ²)	Initial Power (W)	Pwr. Density Calc. (mW/cm ²)	Pwr. Density Max Calc. (mW/cm ²)	
Roof (cnt)	HAF4017A	5.15	60	E	0.78	0.030	36.0	0.015	0.02	
Measurement Grid										
Test Position	Height (cm)	% of Control Limit			Test Position	Height (cm)	% of Control Limit		IEEE Controlled Limit	IEEE Uncontrolled Limit
1	20	0.6%			6	120	1.2%		2.58	0.52
2	40	0.2%			7	140	1.6%			
3	60	0.5%			8	160	1.6%			
4	80	0.6%			9	180	1.8%			
5	100	0.6%			10	200	3.1%			
									RF Po (*Max)	36.0

BS-Position 4

Table 174

External Vehicle MPE Assessment @ 775.9125 MHz										
Antenna Location	Antenna Model	Gain (dBi)	Meas. Distance (cm)	E/H Field	Calibration Factor	Average over Body (mW/cm ²)	Initial Power (W)	Pwr. Density Calc. (mW/cm ²)	Pwr. Density Max Calc. (mW/cm ²)	
Roof (cnt)	HAF4017A	5.15	60	E	0.77	0.028	36.1	0.014	0.01	
Measurement Grid										
Test Position	Height (cm)	% of Control Limit			Test Position	Height (cm)	% of Control Limit		IEEE Controlled Limit	IEEE Uncontrolled Limit
1	20	0.6%			6	120	0.7%		2.59	0.52
2	40	0.2%			7	140	1.0%			
3	60	0.5%			8	160	1.3%			
4	80	0.6%			9	180	2.4%			
5	100	0.6%			10	200	2.8%			
									RF Po (*Max)	36.0

7/800MHz Mobile M20URS9PW1AN

BS-Position 4

Table 175

External Vehicle MPE Assessment @ 794.0875 MHz									
Antenna Location	Antenna Model	Gain (dBi)	Meas. Distance (cm)	E/H Field	Calibration Factor	Average over Body (mW/cm ²)	Initial Power (W)	Pwr. Density Calc. (mW/cm ²)	Pwr. Density Max Calc. (mW/cm ²)
Roof (cnt)	HAF4017A	5.15	60	E	0.76	0.038	37.0	0.019	0.02
Measurement Grid									
Test Position	Height (cm)	% of Control Limit		Test Position	Height (cm)	% of Control Limit		IEEE Controlled Limit	IEEE Uncontrolled Limit
1	20	0.4%		6	120	1.4%		2.65	0.53
2	40	0.6%		7	140	1.8%			
3	60	1.0%		8	160	1.9%			
4	80	1.1%		9	180	2.3%			
5	100	1.2%		10	200	2.8%			
								RF Po (*Max)	36.0

BS-Position 4

Table 176

External Vehicle MPE Assessment @ 809.0125 MHz									
Antenna Location	Antenna Model	Gain (dBi)	Meas. Distance (cm)	E/H Field	Calibration Factor	Average over Body (mW/cm ²)	Initial Power (W)	Pwr. Density Calc. (mW/cm ²)	Pwr. Density Max Calc. (mW/cm ²)
Roof (cnt)	HAF4017A	5.15	60	E	0.75	0.050	41.3	0.025	0.03
Measurement Grid									
Test Position	Height (cm)	% of Control Limit		Test Position	Height (cm)	% of Control Limit		IEEE Controlled Limit	IEEE Uncontrolled Limit
1	20	0.7%		6	120	1.8%		2.70	0.54
2	40	0.3%		7	140	2.2%			
3	60	0.7%		8	160	3.2%			
4	80	0.9%		9	180	3.3%			
5	100	1.6%		10	200	4.0%			
								RF Po (*Max)	42.0

BS-Position 4

Table 177

External Vehicle MPE Assessment @ 823.9875 MHz									
Antenna Location	Antenna Model	Gain (dBi)	Meas. Distance (cm)	E/H Field	Calibration Factor	Average over Body (mW/cm ²)	Initial Power (W)	Pwr. Density Calc. (mW/cm ²)	Pwr. Density Max Calc. (mW/cm ²)
Roof (cnt)	HAF4017A	5.15	60	E	0.74	0.052	41.6	0.026	0.03
Measurement Grid									
Test Position	Height (cm)	% of Control Limit		Test Position	Height (cm)	% of Control Limit		IEEE Controlled Limit	IEEE Uncontrolled Limit
1	20	1.0%		6	120	2.0%		2.75	0.55
2	40	0.4%		7	140	2.5%			
3	60	0.7%		8	160	3.3%			
4	80	1.0%		9	180	3.1%			
5	100	1.2%		10	200	3.9%			
								RF Po (*Max)	42.0

7/800MHz Mobile M20URS9PW1AN

BS-Position 4

Table 178

External Vehicle MPE Assessment @ 851.0125 MHz									
Antenna Location	Antenna Model	Gain (dBi)	Meas. Distance (cm)	E/H Field	Calibration Factor	Average over Body (mW/cm ²)	Initial Power (W)	Pwr. Density Calc. (mW/cm ²)	Pwr. Density Max Calc. (mW/cm ²)
Roof (cnt)	HAF4017A	5.15	60	E	0.73	0.050	41.9	0.025	0.03
Measurement Grid									
Test Position	Height (cm)	% of Control Limit		Test Position	Height (cm)	% of Control Limit		IEEE Controlled Limit	IEEE Uncontrolled Limit
1	20	0.9%		6	120	2.2%		2.84	0.57
2	40	0.4%		7	140	2.2%			
3	60	0.6%		8	160	3.3%			
4	80	0.9%		9	180	3.3%			
5	100	1.2%		10	200	2.7%			
								RF Po (*Max)	
								42.0	

BS-Position 4

Table 179

External Vehicle MPE Assessment @ 859.0125 MHz									
Antenna Location	Antenna Model	Gain (dBi)	Meas. Distance (cm)	E/H Field	Calibration Factor	Average over Body (mW/cm ²)	Initial Power (W)	Pwr. Density Calc. (mW/cm ²)	Pwr. Density Max Calc. (mW/cm ²)
Roof (cnt)	HAF4017A	5.15	60	E	0.72	0.050	41.7	0.025	0.03
Measurement Grid									
Test Position	Height (cm)	% of Control Limit		Test Position	Height (cm)	% of Control Limit		IEEE Controlled Limit	IEEE Uncontrolled Limit
1	20	0.7%		6	120	1.9%		2.86	0.57
2	40	0.4%		7	140	2.1%			
3	60	0.9%		8	160	3.0%			
4	80	1.1%		9	180	3.3%			
5	100	1.4%		10	200	2.6%			
								RF Po (*Max)	
								42.0	

BS-Position 4

Table 180

External Vehicle MPE Assessment @ 868.9875 MHz									
Antenna Location	Antenna Model	Gain (dBi)	Meas. Distance (cm)	E/H Field	Calibration Factor	Average over Body (mW/cm ²)	Initial Power (W)	Pwr. Density Calc. (mW/cm ²)	Pwr. Density Max Calc. (mW/cm ²)
Roof (cnt)	HAF4017A	5.15	60	E	0.71	0.055	41.9	0.028	0.03
Measurement Grid									
Test Position	Height (cm)	% of Control Limit		Test Position	Height (cm)	% of Control Limit		IEEE Controlled Limit	IEEE Uncontrolled Limit
1	20	1.0%		6	120	2.1%		2.90	0.58
2	40	0.9%		7	140	2.2%			
3	60	0.9%		8	160	3.1%			
4	80	1.1%		9	180	3.1%			
5	100	1.2%		10	200	3.4%			
								RF Po (*Max)	
								42.0	

7/800MHz Mobile M20URS9PW1AN

BS-Position 5

Table 181

External Vehicle MPE Assessment @ 764.0875 MHz									
Antenna Location	Antenna Model	Gain (dBi)	Meas. Distance (cm)	E/H Field	Calibration Factor	Average over Body (mW/cm ²)	Initial Power (W)	Pwr. Density Calc. (mW/cm ²)	Pwr. Density Max Calc. (mW/cm ²)
Roof (cnt)	HAF4016A	2.15	60	E	0.78	0.031	36.0	0.015	0.02
Measurement Grid									
Test Position	Height (cm)	% of Control Limit		Test Position	Height (cm)	% of Control Limit		IEEE Controlled Limit	IEEE Uncontrolled Limit
1	20	0.1%		6	120	0.8%		2.55	0.51
2	40	0.1%		7	140	1.3%			
3	60	0.2%		8	160	2.5%			
4	80	0.3%		9	180	3.9%			
5	100	0.6%		10	200	2.3%			
								RF Po (*Max)	
								36.0	

BS-Position 5

Table 182

External Vehicle MPE Assessment @ 773.0125 MHz									
Antenna Location	Antenna Model	Gain (dBi)	Meas. Distance (cm)	E/H Field	Calibration Factor	Average over Body (mW/cm ²)	Initial Power (W)	Pwr. Density Calc. (mW/cm ²)	Pwr. Density Max Calc. (mW/cm ²)
Roof (cnt)	HAF4016A	2.15	60	E	0.78	0.035	36.0	0.017	0.02
Measurement Grid									
Test Position	Height (cm)	% of Control Limit		Test Position	Height (cm)	% of Control Limit		IEEE Controlled Limit	IEEE Uncontrolled Limit
1	20	0.0%		6	120	1.3%		2.58	0.52
2	40	0.0%		7	140	1.7%			
3	60	0.0%		8	160	2.6%			
4	80	0.0%		9	180	4.2%			
5	100	0.1%		10	200	3.5%			
								RF Po (*Max)	
								36.0	

BS-Position 5

Table 183

External Vehicle MPE Assessment @ 775.9125 MHz									
Antenna Location	Antenna Model	Gain (dBi)	Meas. Distance (cm)	E/H Field	Calibration Factor	Average over Body (mW/cm ²)	Initial Power (W)	Pwr. Density Calc. (mW/cm ²)	Pwr. Density Max Calc. (mW/cm ²)
Roof (cnt)	HAF4016A	2.15	60	E	0.77	0.031	36.1	0.015	0.02
Measurement Grid									
Test Position	Height (cm)	% of Control Limit		Test Position	Height (cm)	% of Control Limit		IEEE Controlled Limit	IEEE Uncontrolled Limit
1	20	0.1%		6	120	0.8%		2.59	0.52
2	40	0.1%		7	140	1.2%			
3	60	0.1%		8	160	2.4%			
4	80	0.1%		9	180	3.6%			
5	100	0.5%		10	200	3.0%			
								RF Po (*Max)	
								36.0	

7/800MHz Mobile M20URS9PW1AN

BS-Position 5

Table 184

External Vehicle MPE Assessment @ 794.0875 MHz									
Antenna Location	Antenna Model	Gain (dBi)	Meas. Distance (cm)	E/H Field	Calibration Factor	Average over Body (mW/cm ²)	Initial Power (W)	Pwr. Density Calc. (mW/cm ²)	Pwr. Density Max Calc. (mW/cm ²)
Roof (cnt)	HAF4016A	2.15	60	E	0.76	0.025	37.0	0.013	0.01
Measurement Grid									
Test Position	Height (cm)	% of Control Limit		Test Position	Height (cm)	% of Control Limit		IEEE Controlled Limit	IEEE Uncontrolled Limit
1	20	0.0%		6	120	0.5%		2.65	0.53
2	40	0.1%		7	140	1.0%			
3	60	0.1%		8	160	2.0%			
4	80	0.1%		9	180	3.4%			
5	100	0.2%		10	200	2.2%			
								RF Po (*Max)	
								36.0	

BS-Position 5

Table 185

External Vehicle MPE Assessment @ 809.0125 MHz									
Antenna Location	Antenna Model	Gain (dBi)	Meas. Distance (cm)	E/H Field	Calibration Factor	Average over Body (mW/cm ²)	Initial Power (W)	Pwr. Density Calc. (mW/cm ²)	Pwr. Density Max Calc. (mW/cm ²)
Roof (cnt)	HAF4016A	2.15	60	E	0.75	0.029	41.3	0.014	0.01
Measurement Grid									
Test Position	Height (cm)	% of Control Limit		Test Position	Height (cm)	% of Control Limit		IEEE Controlled Limit	IEEE Uncontrolled Limit
1	20	0.1%		6	120	0.9%		2.70	0.54
2	40	0.0%		7	140	1.1%			
3	60	0.1%		8	160	2.2%			
4	80	0.1%		9	180	3.4%			
5	100	0.4%		10	200	2.4%			
								RF Po (*Max)	
								42.0	

BS-Position 5

Table 186

External Vehicle MPE Assessment @ 823.9875 MHz									
Antenna Location	Antenna Model	Gain (dBi)	Meas. Distance (cm)	E/H Field	Calibration Factor	Average over Body (mW/cm ²)	Initial Power (W)	Pwr. Density Calc. (mW/cm ²)	Pwr. Density Max Calc. (mW/cm ²)
Roof (cnt)	HAF4016A	2.15	60	E	0.74	0.021	41.6	0.010	0.01
Measurement Grid									
Test Position	Height (cm)	% of Control Limit		Test Position	Height (cm)	% of Control Limit		IEEE Controlled Limit	IEEE Uncontrolled Limit
1	20	0.1%		6	120	0.4%		2.75	0.55
2	40	0.1%		7	140	0.6%			
3	60	0.1%		8	160	1.8%			
4	80	0.1%		9	180	2.5%			
5	100	0.3%		10	200	1.6%			
								RF Po (*Max)	
								42.0	

7/800MHz Mobile M20URS9PW1AN

BS-Position 5

Table 187

External Vehicle MPE Assessment @ 851.0125 MHz									
Antenna Location	Antenna Model	Gain (dBi)	Meas. Distance (cm)	E/H Field	Calibration Factor	Average over Body (mW/cm ²)	Initial Power (W)	Pwr. Density Calc. (mW/cm ²)	Pwr. Density Max Calc. (mW/cm ²)
Roof (cnt)	HAF4016A	2.15	60	E	0.73	0.023	41.9	0.012	0.01
Measurement Grid									
Test Position	Height (cm)	% of Control Limit		Test Position	Height (cm)	% of Control Limit		IEEE Controlled Limit	IEEE Uncontrolled Limit
1	20	0.1%		6	120	0.6%		2.84	0.57
2	40	0.1%		7	140	0.9%			
3	60	0.1%		8	160	2.0%			
4	80	0.1%		9	180	2.6%			
5	100	0.2%		10	200	1.6%			

BS-Position 5

Table 188

External Vehicle MPE Assessment @ 859.0125 MHz									
Antenna Location	Antenna Model	Gain (dBi)	Meas. Distance (cm)	E/H Field	Calibration Factor	Average over Body (mW/cm ²)	Initial Power (W)	Pwr. Density Calc. (mW/cm ²)	Pwr. Density Max Calc. (mW/cm ²)
Roof (cnt)	HAF4016A	2.15	60	E	0.72	0.024	41.7	0.012	0.01
Measurement Grid									
Test Position	Height (cm)	% of Control Limit		Test Position	Height (cm)	% of Control Limit		IEEE Controlled Limit	IEEE Uncontrolled Limit
1	20	0.1%		6	120	0.5%		2.86	0.57
2	40	0.1%		7	140	1.0%			
3	60	0.1%		8	160	2.3%			
4	80	0.1%		9	180	2.7%			
5	100	0.1%		10	200	1.5%			

BS-Position 5

Table 189

External Vehicle MPE Assessment @ 868.9875 MHz									
Antenna Location	Antenna Model	Gain (dBi)	Meas. Distance (cm)	E/H Field	Calibration Factor	Average over Body (mW/cm ²)	Initial Power (W)	Pwr. Density Calc. (mW/cm ²)	Pwr. Density Max Calc. (mW/cm ²)
Roof (cnt)	HAF4016A	2.15	60	E	0.71	0.027	41.9	0.013	0.01
Measurement Grid									
Test Position	Height (cm)	% of Control Limit		Test Position	Height (cm)	% of Control Limit		IEEE Controlled Limit	IEEE Uncontrolled Limit
1	20	0.1%		6	120	1.0%		2.90	0.58
2	40	0.1%		7	140	1.3%			
3	60	0.1%		8	160	2.2%			
4	80	0.1%		9	180	2.7%			
5	100	0.3%		10	200	1.5%			

7/800MHz Mobile M20URS9PW1AN

BS-Position 5

Table 190

External Vehicle MPE Assessment @ 764.0875 MHz									
Antenna Location	Antenna Model	Gain (dBi)	Meas. Distance (cm)	E/H Field	Calibration Factor	Average over Body (mW/cm ²)	Initial Power (W)	Pwr. Density Calc. (mW/cm ²)	Pwr. Density Max Calc. (mW/cm ²)
Roof (cnt)	HAF4014A	5.15	60	E	0.78	0.049	36.0	0.024	0.02
Measurement Grid									
Test Position	Height (cm)	% of Control Limit		Test Position	Height (cm)	% of Control Limit		IEEE Controlled Limit	IEEE Uncontrolled Limit
1	20	0.1%		6	120	1.5%		2.55	0.51
2	40	0.1%		7	140	2.5%			
3	60	0.1%		8	160	4.4%			
4	80	0.4%		9	180	6.0%			
5	100	1.1%		10	200	3.0%			
								RF Po (*Max)	36.0

BS-Position 5

Table 191

External Vehicle MPE Assessment @ 773.0125 MHz									
Antenna Location	Antenna Model	Gain (dBi)	Meas. Distance (cm)	E/H Field	Calibration Factor	Average over Body (mW/cm ²)	Initial Power (W)	Pwr. Density Calc. (mW/cm ²)	Pwr. Density Max Calc. (mW/cm ²)
Roof (cnt)	HAF4014A	5.15	60	E	0.78	0.062	36.0	0.031	0.03
Measurement Grid									
Test Position	Height (cm)	% of Control Limit		Test Position	Height (cm)	% of Control Limit		IEEE Controlled Limit	IEEE Uncontrolled Limit
1	20	0.1%		6	120	2.6%		2.58	0.52
2	40	0.1%		7	140	3.8%			
3	60	0.1%		8	160	4.6%			
4	80	0.6%		9	180	6.6%			
5	100	2.0%		10	200	3.5%			
								RF Po (*Max)	36.0

BS-Position 5

Table 192

External Vehicle MPE Assessment @ 775.9125 MHz									
Antenna Location	Antenna Model	Gain (dBi)	Meas. Distance (cm)	E/H Field	Calibration Factor	Average over Body (mW/cm ²)	Initial Power (W)	Pwr. Density Calc. (mW/cm ²)	Pwr. Density Max Calc. (mW/cm ²)
Roof (cnt)	HAF4014A	5.15	60	E	0.77	0.061	36.1	0.030	0.03
Measurement Grid									
Test Position	Height (cm)	% of Control Limit		Test Position	Height (cm)	% of Control Limit		IEEE Controlled Limit	IEEE Uncontrolled Limit
1	20	0.1%		6	120	2.3%		2.59	0.52
2	40	0.1%		7	140	3.8%			
3	60	0.1%		8	160	4.7%			
4	80	0.6%		9	180	6.4%			
5	100	2.3%		10	200	3.1%			
								RF Po (*Max)	36.0

7/800MHz Mobile M20URS9PW1AN

BS-Position 5

Table 193

External Vehicle MPE Assessment @ 794.0875 MHz									
Antenna Location	Antenna Model	Gain (dBi)	Meas. Distance (cm)	E/H Field	Calibration Factor	Average over Body (mW/cm ²)	Initial Power (W)	Pwr. Density Calc. (mW/cm ²)	Pwr. Density Max Calc. (mW/cm ²)
Roof (cnt)	HAF4014A	5.15	60	E	0.76	0.049	37.0	0.024	0.02
Measurement Grid									
Test Position	Height (cm)	% of Control Limit		Test Position	Height (cm)	% of Control Limit		IEEE Controlled Limit	IEEE Uncontrolled Limit
1	20	0.1%		6	120	1.4%		2.65	0.53
2	40	0.0%		7	140	2.7%			
3	60	0.1%		8	160	4.2%			
4	80	0.3%		9	180	5.6%			
5	100	1.5%		10	200	2.5%			
								RF Po (*Max)	
								36.0	

BS-Position 5

Table 194

External Vehicle MPE Assessment @ 809.0125 MHz									
Antenna Location	Antenna Model	Gain (dBi)	Meas. Distance (cm)	E/H Field	Calibration Factor	Average over Body (mW/cm ²)	Initial Power (W)	Pwr. Density Calc. (mW/cm ²)	Pwr. Density Max Calc. (mW/cm ²)
Roof (cnt)	HAF4014A	5.15	60	E	0.75	0.052	41.3	0.026	0.03
Measurement Grid									
Test Position	Height (cm)	% of Control Limit		Test Position	Height (cm)	% of Control Limit		IEEE Controlled Limit	IEEE Uncontrolled Limit
1	20	0.0%		6	120	2.2%		2.70	0.54
2	40	0.0%		7	140	2.6%			
3	60	0.1%		8	160	4.1%			
4	80	0.5%		9	180	5.7%			
5	100	1.5%		10	200	2.5%			
								RF Po (*Max)	
								42.0	

BS-Position 5

Table 195

External Vehicle MPE Assessment @ 823.9875 MHz									
Antenna Location	Antenna Model	Gain (dBi)	Meas. Distance (cm)	E/H Field	Calibration Factor	Average over Body (mW/cm ²)	Initial Power (W)	Pwr. Density Calc. (mW/cm ²)	Pwr. Density Max Calc. (mW/cm ²)
Roof (cnt)	HAF4014A	5.15	60	E	0.74	0.036	41.6	0.018	0.02
Measurement Grid									
Test Position	Height (cm)	% of Control Limit		Test Position	Height (cm)	% of Control Limit		IEEE Controlled Limit	IEEE Uncontrolled Limit
1	20	0.0%		6	120	0.9%		2.75	0.55
2	40	0.0%		7	140	1.6%			
3	60	0.0%		8	160	3.2%			
4	80	0.5%		9	180	4.3%			
5	100	0.8%		10	200	1.8%			
								RF Po (*Max)	
								42.0	

7/800MHz Mobile M20URS9PW1AN

BS-Position 5

Table 196

External Vehicle MPE Assessment @ 851.0125 MHz									
Antenna Location	Antenna Model	Gain (dBi)	Meas. Distance (cm)	E/H Field	Calibration Factor	Average over Body (mW/cm ²)	Initial Power (W)	Pwr. Density Calc. (mW/cm ²)	Pwr. Density Max Calc. (mW/cm ²)
Roof (cnt)	HAF4014A	5.15	60	E	0.73	0.039	41.9	0.020	0.02
Measurement Grid									
Test Position	Height (cm)	% of Control Limit		Test Position	Height (cm)	% of Control Limit		IEEE Controlled Limit	IEEE Uncontrolled Limit
1	20	0.0%		6	120	1.6%		2.84	0.57
2	40	0.0%		7	140	2.1%			
3	60	0.1%		8	160	3.6%			
4	80	0.3%		9	180	3.7%			
5	100	0.9%		10	200	1.5%			
								RF Po (*Max)	
								42.0	

BS-Position 5

Table 197

External Vehicle MPE Assessment @ 859.0125 MHz									
Antenna Location	Antenna Model	Gain (dBi)	Meas. Distance (cm)	E/H Field	Calibration Factor	Average over Body (mW/cm ²)	Initial Power (W)	Pwr. Density Calc. (mW/cm ²)	Pwr. Density Max Calc. (mW/cm ²)
Roof (cnt)	HAF4014A	5.15	60	E	0.72	0.036	41.7	0.018	0.02
Measurement Grid									
Test Position	Height (cm)	% of Control Limit		Test Position	Height (cm)	% of Control Limit		IEEE Controlled Limit	IEEE Uncontrolled Limit
1	20	0.0%		6	120	1.5%		2.86	0.57
2	40	0.0%		7	140	2.0%			
3	60	0.1%		8	160	3.5%			
4	80	0.3%		9	180	3.3%			
5	100	0.5%		10	200	1.4%			
								RF Po (*Max)	
								42.0	

BS-Position 5

Table 198

External Vehicle MPE Assessment @ 868.9875 MHz									
Antenna Location	Antenna Model	Gain (dBi)	Meas. Distance (cm)	E/H Field	Calibration Factor	Average over Body (mW/cm ²)	Initial Power (W)	Pwr. Density Calc. (mW/cm ²)	Pwr. Density Max Calc. (mW/cm ²)
Roof (cnt)	HAF4014A	5.15	60	E	0.71	0.042	41.9	0.021	0.02
Measurement Grid									
Test Position	Height (cm)	% of Control Limit		Test Position	Height (cm)	% of Control Limit		IEEE Controlled Limit	IEEE Uncontrolled Limit
1	20	0.0%		6	120	2.3%		2.90	0.58
2	40	0.0%		7	140	2.5%			
3	60	0.0%		8	160	3.9%			
4	80	0.3%		9	180	3.5%			
5	100	0.7%		10	200	1.4%			
								RF Po (*Max)	
								42.0	

7/800MHz Mobile M20URS9PW1AN

BS-Position 5

Table 199

External Vehicle MPE Assessment @ 764.0875 MHz									
Antenna Location	Antenna Model	Gain (dBi)	Meas. Distance (cm)	E/H Field	Calibration Factor	Average over Body (mW/cm ²)	Initial Power (W)	Pwr. Density Calc. (mW/cm ²)	Pwr. Density Max Calc. (mW/cm ²)
Roof (cnt)	HAF4013A	5.15	60	E	0.78	0.027	36.0	0.013	0.01
Measurement Grid									
Test Position	Height (cm)	% of Control Limit		Test Position	Height (cm)	% of Control Limit		IEEE Controlled Limit	IEEE Uncontrolled Limit
1	20	0.0%		6	120	0.4%		2.55	0.51
2	40	0.0%		7	140	0.9%			
3	60	0.0%		8	160	2.5%			
4	80	0.1%		9	180	3.7%			
5	100	0.2%		10	200	2.7%			
								RF Po (*Max)	36.0

BS-Position 5

Table 200

External Vehicle MPE Assessment @ 773.0125 MHz									
Antenna Location	Antenna Model	Gain (dBi)	Meas. Distance (cm)	E/H Field	Calibration Factor	Average over Body (mW/cm ²)	Initial Power (W)	Pwr. Density Calc. (mW/cm ²)	Pwr. Density Max Calc. (mW/cm ²)
Roof (cnt)	HAF4013A	5.15	60	E	0.78	0.029	36.0	0.014	0.01
Measurement Grid									
Test Position	Height (cm)	% of Control Limit		Test Position	Height (cm)	% of Control Limit		IEEE Controlled Limit	IEEE Uncontrolled Limit
1	20	0.0%		6	120	0.7%		2.58	0.52
2	40	0.0%		7	140	1.2%			
3	60	0.0%		8	160	2.2%			
4	80	0.0%		9	180	3.7%			
5	100	0.3%		10	200	3.1%			
								RF Po (*Max)	36.0

BS-Position 5

Table 201

External Vehicle MPE Assessment @ 775.9125 MHz									
Antenna Location	Antenna Model	Gain (dBi)	Meas. Distance (cm)	E/H Field	Calibration Factor	Average over Body (mW/cm ²)	Initial Power (W)	Pwr. Density Calc. (mW/cm ²)	Pwr. Density Max Calc. (mW/cm ²)
Roof (cnt)	HAF4013A	5.15	60	E	0.77	0.027	36.1	0.014	0.01
Measurement Grid									
Test Position	Height (cm)	% of Control Limit		Test Position	Height (cm)	% of Control Limit		IEEE Controlled Limit	IEEE Uncontrolled Limit
1	20	0.0%		6	120	0.8%		2.59	0.52
2	40	0.0%		7	140	1.1%			
3	60	0.0%		8	160	1.9%			
4	80	0.0%		9	180	3.3%			
5	100	0.6%		10	200	2.8%			
								RF Po (*Max)	36.0

7/800MHz Mobile M20URS9PW1AN

BS-Position 5

Table 202

External Vehicle MPE Assessment @ 794.0875 MHz									
Antenna Location	Antenna Model	Gain (dBi)	Meas. Distance (cm)	E/H Field	Calibration Factor	Average over Body (mW/cm ²)	Initial Power (W)	Pwr. Density Calc. (mW/cm ²)	Pwr. Density Max Calc. (mW/cm ²)
Roof (cnt)	HAF4013A	5.15	60	E	0.76	0.024	37.0	0.012	0.01
Measurement Grid									
Test Position	Height (cm)	% of Control Limit		Test Position	Height (cm)	% of Control Limit		IEEE Controlled Limit	IEEE Uncontrolled Limit
1	20	0.0%		6	120	0.3%		2.65	0.53
2	40	0.0%		7	140	0.7%			
3	60	0.0%		8	160	1.9%			
4	80	0.0%		9	180	3.4%			
5	100	0.3%		10	200	2.5%			
								RF Po (*Max)	36.0

BS-Position 5

Table 203

External Vehicle MPE Assessment @ 809.0125 MHz									
Antenna Location	Antenna Model	Gain (dBi)	Meas. Distance (cm)	E/H Field	Calibration Factor	Average over Body (mW/cm ²)	Initial Power (W)	Pwr. Density Calc. (mW/cm ²)	Pwr. Density Max Calc. (mW/cm ²)
Roof (cnt)	HAF4013A	5.15	60	E	0.75	0.026	41.3	0.013	0.01
Measurement Grid									
Test Position	Height (cm)	% of Control Limit		Test Position	Height (cm)	% of Control Limit		IEEE Controlled Limit	IEEE Uncontrolled Limit
1	20	0.0%		6	120	0.5%		2.70	0.54
2	40	0.0%		7	140	0.9%			
3	60	0.0%		8	160	1.8%			
4	80	0.0%		9	180	3.6%			
5	100	0.3%		10	200	2.4%			
								RF Po (*Max)	42.0

BS-Position 5

Table 204

External Vehicle MPE Assessment @ 823.9875 MHz									
Antenna Location	Antenna Model	Gain (dBi)	Meas. Distance (cm)	E/H Field	Calibration Factor	Average over Body (mW/cm ²)	Initial Power (W)	Pwr. Density Calc. (mW/cm ²)	Pwr. Density Max Calc. (mW/cm ²)
Roof (cnt)	HAF4013A	5.15	60	E	0.74	0.019	41.6	0.009	0.01
Measurement Grid									
Test Position	Height (cm)	% of Control Limit		Test Position	Height (cm)	% of Control Limit		IEEE Controlled Limit	IEEE Uncontrolled Limit
1	20	0.0%		6	120	0.3%		2.75	0.55
2	40	0.0%		7	140	0.5%			
3	60	0.0%		8	160	1.2%			
4	80	0.0%		9	180	2.9%			
5	100	0.2%		10	200	1.7%			
								RF Po (*Max)	42.0

7/800MHz Mobile M20URS9PW1AN

BS-Position 5

Table 205

External Vehicle MPE Assessment @ 851.0125 MHz									
Antenna Location	Antenna Model	Gain (dBi)	Meas. Distance (cm)	E/H Field	Calibration Factor	Average over Body (mW/cm ²)	Initial Power (W)	Pwr. Density Calc. (mW/cm ²)	Pwr. Density Max Calc. (mW/cm ²)
Roof (cnt)	HAF4013A	5.15	60	E	0.73	0.023	41.9	0.011	0.01
Measurement Grid									
Test Position	Height (cm)	% of Control Limit		Test Position	Height (cm)	% of Control Limit		IEEE Controlled Limit	IEEE Uncontrolled Limit
1	20	0.0%		6	120	0.5%		2.84	0.57
2	40	0.0%		7	140	0.9%			
3	60	0.0%		8	160	2.1%			
4	80	0.0%		9	180	2.8%			
5	100	0.1%		10	200	1.7%			
								RF Po (*Max)	
								42.0	

BS-Position 5

Table 206

External Vehicle MPE Assessment @ 859.0125 MHz									
Antenna Location	Antenna Model	Gain (dBi)	Meas. Distance (cm)	E/H Field	Calibration Factor	Average over Body (mW/cm ²)	Initial Power (W)	Pwr. Density Calc. (mW/cm ²)	Pwr. Density Max Calc. (mW/cm ²)
Roof (cnt)	HAF4013A	5.15	60	E	0.72	0.024	41.7	0.012	0.01
Measurement Grid									
Test Position	Height (cm)	% of Control Limit		Test Position	Height (cm)	% of Control Limit		IEEE Controlled Limit	IEEE Uncontrolled Limit
1	20	0.0%		6	120	0.6%		2.86	0.57
2	40	0.0%		7	140	1.0%			
3	60	0.0%		8	160	2.4%			
4	80	0.0%		9	180	2.7%			
5	100	0.1%		10	200	1.6%			
								RF Po (*Max)	
								42.0	

BS-Position 5

Table 207

External Vehicle MPE Assessment @ 868.9875 MHz									
Antenna Location	Antenna Model	Gain (dBi)	Meas. Distance (cm)	E/H Field	Calibration Factor	Average over Body (mW/cm ²)	Initial Power (W)	Pwr. Density Calc. (mW/cm ²)	Pwr. Density Max Calc. (mW/cm ²)
Roof (cnt)	HAF4013A	5.15	60	E	0.71	0.027	41.9	0.014	0.01
Measurement Grid									
Test Position	Height (cm)	% of Control Limit		Test Position	Height (cm)	% of Control Limit		IEEE Controlled Limit	IEEE Uncontrolled Limit
1	20	0.0%		6	120	0.9%		2.90	0.58
2	40	0.0%		7	140	1.5%			
3	60	0.0%		8	160	2.3%			
4	80	0.0%		9	180	3.0%			
5	100	0.2%		10	200	1.5%			
								RF Po (*Max)	
								42.0	

7/800MHz Mobile M20URS9PW1AN

BS-Position 5

Table 208

External Vehicle MPE Assessment @ 764.0875 MHz									
Antenna Location	Antenna Model	Gain (dBi)	Meas. Distance (cm)	E/H Field	Calibration Factor	Average over Body (mW/cm ²)	Initial Power (W)	Pwr. Density Calc. (mW/cm ²)	Pwr. Density Max Calc. (mW/cm ²)
Roof (cnt)	HAF4017A	5.15	60	E	0.78	0.010	36.0	0.005	0.01
Measurement Grid									
Test Position	Height (cm)	% of Control Limit		Test Position	Height (cm)	% of Control Limit		IEEE Controlled Limit	IEEE Uncontrolled Limit
1	20	0.0%		6	120	0.0%		2.55	0.51
2	40	0.0%		7	140	0.1%			
3	60	0.0%		8	160	0.9%			
4	80	0.0%		9	180	1.4%			
5	100	0.0%		10	200	1.7%			
								RF Po (*Max)	36.0

BS-Position 5

Table 209

External Vehicle MPE Assessment @ 773.0125 MHz									
Antenna Location	Antenna Model	Gain (dBi)	Meas. Distance (cm)	E/H Field	Calibration Factor	Average over Body (mW/cm ²)	Initial Power (W)	Pwr. Density Calc. (mW/cm ²)	Pwr. Density Max Calc. (mW/cm ²)
Roof (cnt)	HAF4017A	5.15	60	E	0.78	0.012	36.0	0.006	0.01
Measurement Grid									
Test Position	Height (cm)	% of Control Limit		Test Position	Height (cm)	% of Control Limit		IEEE Controlled Limit	IEEE Uncontrolled Limit
1	20	0.0%		6	120	0.0%		2.58	0.52
2	40	0.0%		7	140	0.3%			
3	60	0.0%		8	160	0.9%			
4	80	0.0%		9	180	1.7%			
5	100	0.0%		10	200	1.6%			
								RF Po (*Max)	36.0

BS-Position 5

Table 210

External Vehicle MPE Assessment @ 775.9125 MHz									
Antenna Location	Antenna Model	Gain (dBi)	Meas. Distance (cm)	E/H Field	Calibration Factor	Average over Body (mW/cm ²)	Initial Power (W)	Pwr. Density Calc. (mW/cm ²)	Pwr. Density Max Calc. (mW/cm ²)
Roof (cnt)	HAF4017A	5.15	60	E	0.77	0.014	36.1	0.007	0.01
Measurement Grid									
Test Position	Height (cm)	% of Control Limit		Test Position	Height (cm)	% of Control Limit		IEEE Controlled Limit	IEEE Uncontrolled Limit
1	20	0.0%		6	120	0.1%		2.59	0.52
2	40	0.0%		7	140	0.5%			
3	60	0.0%		8	160	1.0%			
4	80	0.0%		9	180	1.9%			
5	100	0.0%		10	200	1.8%			
								RF Po (*Max)	36.0

7/800MHz Mobile M20URS9PW1AN

BS-Position 5

Table 211

External Vehicle MPE Assessment @ 794.0875 MHz									
Antenna Location	Antenna Model	Gain (dBi)	Meas. Distance (cm)	E/H Field	Calibration Factor	Average over Body (mW/cm ²)	Initial Power (W)	Pwr. Density Calc. (mW/cm ²)	Pwr. Density Max Calc. (mW/cm ²)
Roof (cnt)	HAF4017A	5.15	60	E	0.76	0.021	37.0	0.010	0.01
Measurement Grid									
Test Position	Height (cm)	% of Control Limit		Test Position	Height (cm)	% of Control Limit		IEEE Controlled Limit	IEEE Uncontrolled Limit
1	20	0.0%		6	120	0.3%		2.65	0.53
2	40	0.0%		7	140	0.8%			
3	60	0.0%		8	160	2.5%			
4	80	0.0%		9	180	2.7%			
5	100	0.0%		10	200	1.6%			
								RF Po (*Max)	36.0

BS-Position 5

Table 212

External Vehicle MPE Assessment @ 809.0125 MHz									
Antenna Location	Antenna Model	Gain (dBi)	Meas. Distance (cm)	E/H Field	Calibration Factor	Average over Body (mW/cm ²)	Initial Power (W)	Pwr. Density Calc. (mW/cm ²)	Pwr. Density Max Calc. (mW/cm ²)
Roof (cnt)	HAF4017A	5.15	60	E	0.75	0.036	41.3	0.018	0.02
Measurement Grid									
Test Position	Height (cm)	% of Control Limit		Test Position	Height (cm)	% of Control Limit		IEEE Controlled Limit	IEEE Uncontrolled Limit
1	20	0.0%		6	120	0.8%		2.70	0.54
2	40	0.0%		7	140	2.0%			
3	60	0.0%		8	160	4.4%			
4	80	0.1%		9	180	3.3%			
5	100	0.3%		10	200	2.3%			
								RF Po (*Max)	42.0

BS-Position 5

Table 213

External Vehicle MPE Assessment @ 823.9875 MHz									
Antenna Location	Antenna Model	Gain (dBi)	Meas. Distance (cm)	E/H Field	Calibration Factor	Average over Body (mW/cm ²)	Initial Power (W)	Pwr. Density Calc. (mW/cm ²)	Pwr. Density Max Calc. (mW/cm ²)
Roof (cnt)	HAF4017A	5.15	60	E	0.74	0.037	41.6	0.018	0.02
Measurement Grid									
Test Position	Height (cm)	% of Control Limit		Test Position	Height (cm)	% of Control Limit		IEEE Controlled Limit	IEEE Uncontrolled Limit
1	20	0.0%		6	120	1.3%		2.75	0.55
2	40	0.0%		7	140	2.4%			
3	60	0.0%		8	160	3.8%			
4	80	0.3%		9	180	3.2%			
5	100	0.4%		10	200	1.9%			
								RF Po (*Max)	42.0

7/800MHz Mobile M20URS9PW1AN

BS-Position 5

Table 214

External Vehicle MPE Assessment @ 851.0125 MHz									
Antenna Location	Antenna Model	Gain (dBi)	Meas. Distance (cm)	E/H Field	Calibration Factor	Average over Body (mW/cm ²)	Initial Power (W)	Pwr. Density Calc. (mW/cm ²)	Pwr. Density Max Calc. (mW/cm ²)
Roof (cnt)	HAF4017A	5.15	60	E	0.73	0.041	41.9	0.020	0.02
Measurement Grid									
Test Position	Height (cm)	% of Control Limit		Test Position	Height (cm)	% of Control Limit		IEEE Controlled Limit	IEEE Uncontrolled Limit
1	20	0.0%		6	120	1.9%		2.84	0.57
2	40	0.0%		7	140	2.6%			
3	60	0.0%		8	160	4.8%			
4	80	0.3%		9	180	2.8%			
5	100	0.7%		10	200	1.3%			
								RF Po (*Max)	42.0

BS-Position 5

Table 215

External Vehicle MPE Assessment @ 859.0125 MHz									
Antenna Location	Antenna Model	Gain (dBi)	Meas. Distance (cm)	E/H Field	Calibration Factor	Average over Body (mW/cm ²)	Initial Power (W)	Pwr. Density Calc. (mW/cm ²)	Pwr. Density Max Calc. (mW/cm ²)
Roof (cnt)	HAF4017A	5.15	60	E	0.72	0.034	41.7	0.017	0.02
Measurement Grid									
Test Position	Height (cm)	% of Control Limit		Test Position	Height (cm)	% of Control Limit		IEEE Controlled Limit	IEEE Uncontrolled Limit
1	20	0.0%		6	120	1.5%		2.86	0.57
2	40	0.0%		7	140	2.4%			
3	60	0.0%		8	160	3.6%			
4	80	0.3%		9	180	2.3%			
5	100	0.5%		10	200	1.3%			
								RF Po (*Max)	42.0

BS-Position 5

Table 216

External Vehicle MPE Assessment @ 868.9875 MHz									
Antenna Location	Antenna Model	Gain (dBi)	Meas. Distance (cm)	E/H Field	Calibration Factor	Average over Body (mW/cm ²)	Initial Power (W)	Pwr. Density Calc. (mW/cm ²)	Pwr. Density Max Calc. (mW/cm ²)
Roof (cnt)	HAF4017A	5.15	60	E	0.71	0.034	41.9	0.017	0.02
Measurement Grid									
Test Position	Height (cm)	% of Control Limit		Test Position	Height (cm)	% of Control Limit		IEEE Controlled Limit	IEEE Uncontrolled Limit
1	20	0.0%		6	120	2.2%		2.90	0.58
2	40	0.0%		7	140	2.6%			
3	60	0.0%		8	160	3.0%			
4	80	0.1%		9	180	1.8%			
5	100	0.8%		10	200	1.1%			
								RF Po (*Max)	42.0