

# ENGINEERING TEST REPORT

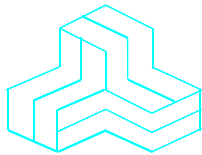

**DVRS Vehicular Repeater**  
**Model: DVR-LX 700**

**FCC ID: LO6-DVRS700**  
**IC: 2098B-DVRS700**

*Applicant:*

**Futurecom Systems Group, ULC**  
3277 Langstaff Road  
Concord, Ontario  
Canada, L4K 5P8

**Tested in Accordance With**

**Federal Communications Commission (FCC)**  
**47 CFR, Parts 2 and 90 (Subpart R)**  
**Industry Canada, RSS-119, Issue 12**

**UltraTech's File No.: 20FSG188\_FCC90R**

*This Test report is Issued under the Authority of*  
*Tri M. Luu*  
*Vice President of Engineering*  
*UltraTech Group of Labs*

*Date: March 13, 2020*

*Report Prepared by: Santhosh Fernandez*

*Tested by: Hung Trinh*

*Issued Date: March 13, 2020*

*Test Dates: February 6 and 7, 2020*

- *The results in this Test Report apply only to the sample(s) tested, and the sample tested is randomly selected.*
- *This report must not be used by the client to claim product endorsement by any agency of the US Government.*
- *This test report shall not be reproduced, except in full, without a written approval from UltraTech*

## UltraTech

3000 Bristol Circle, Oakville, Ontario, Canada L6H 6G4  
Tel.: (905) 829-1570 Fax.: (905) 829-8050

Website: [www.ultratech-labs.com](http://www.ultratech-labs.com), Email: [vic@ultratech-labs.com](mailto:vic@ultratech-labs.com), Email: [tri@ultratech-labs.com](mailto:tri@ultratech-labs.com)



#0685  
ISO/IEC 17065  
Product Certification Body



APEC TEL CA0001



1309



CA 0001/2049



AT-1945



SL2-IN-E-1119R



Korea KCC-RRR  
CA0001

TABLE OF CONTENTS

MARCH 13, 2020 ..... 1
EXHIBIT 1. INTRODUCTION ..... 1
1.1. SCOPE..... 1
1.2. RELATED SUBMITTAL(S)/GRANT(S)..... 1
1.3. NORMATIVE REFERENCES ..... 1
EXHIBIT 2. PERFORMANCE ASSESSMENT ..... 2
2.1. CLIENT INFORMATION ..... 2
2.2. EQUIPMENT UNDER TEST (EUT) INFORMATION..... 2
2.3. EUT'S TECHNICAL SPECIFICATIONS ..... 3
2.4. LIST OF EUT'S PORTS ..... 3
2.5. ANCILLARY EQUIPMENT ..... 3
EXHIBIT 3. EUT OPERATING CONDITIONS AND CONFIGURATIONS DURING TESTS ..... 4
3.1. CLIMATE TEST CONDITIONS ..... 4
3.2. OPERATIONAL TEST CONDITIONS & ARRANGEMENT FOR TEST SIGNALS ..... 4
EXHIBIT 4. SUMMARY OF TEST RESULTS ..... 5
4.1. LOCATION OF TESTS ..... 5
• AC POWER LINE CONDUCTED EMISSIONS WERE PERFORMED IN ULTRATECH'S SHIELDED ROOM, 24'(L) BY 16'(W) BY 8'(H). ..... 5
4.2. APPLICABILITY & SUMMARY OF EMISSION TEST RESULTS..... 5
4.3. MODIFICATIONS INCORPORATED IN THE EUT FOR COMPLIANCE PURPOSES..... 5
4.4. DEVIATION OF STANDARD TEST PROCEDURES ..... 5
EXHIBIT 5. TEST DATA..... 6
5.1. RF POWER OUTPUT [§§ 2.1046 & 90.541] [RSS-119 § 5.4] ..... 6
5.1.1. Limits ..... 6
THE OUTPUT POWER SHALL BE WITHIN + 1.0 DB OF THE MANUFACTURER'S RATED POWER. .... 6
THE TRANSMITTER OUTPUT POWER LIMITS ..... 6
5.1.2. Method of Measurements..... 7
5.1.3..... 7
5.1.4. Test Equipment List ..... 7
5.1.5. Test Arrangement ..... 7
5.1.6. Test Data ..... 8
5.2. TRANSMITTER SPURIOUS/HARMONIC RADIATED EMISSIONS [§ 90.543(c) & (E)] [RSS-119 §§ 5.5 & 5.8]
9
5.2.1. Limits ..... 9
5.2.2. Method of Measurements..... 10
5.2.3. Test Equipment list ..... 10
5.2.4. Test Arrangement ..... 11
5.3. RADIATED EMISSIONS FROM UNINTENTIONAL RADIATORS [ICES-003] ..... 14
5.3.1. Limits ..... 14
5.3.2. Method of Measurements..... 14
5.3.3. Test Equipment list ..... 14
5.3.4. Test Arrangement ..... 15

ULTRATECH GROUP OF LABS

3000 Bristol Circle, Oakville, Ontario, Canada L6H 6G4

Tel. #: 905-829-1570, Fax. #: 905-829-8050, Email: vic@ultratech-labs.com, Website: http://www.ultratech-labs.com

File #: 20FSG188\_FCC90R

March 13, 2020

All test results contained in this engineering test report are traceable to National Institute of Standards and Technology (NIST)

---



---

5.3.5. Test Data ..... 15

**EXHIBIT 6. MEASUREMENT UNCERTAINTY..... 16**

6.1. RADIATED EMISSION MEASUREMENT UNCERTAINTY ..... 16

## EXHIBIT 1. INTRODUCTION

### 1.1. SCOPE

Reference:	FCC Parts 2 and 90 (Subpart R)
Title:	Code of Federal Regulations (CFR) Title 47 Telecommunication, Parts 2 & 90
Purpose of Test:	To gain FCC C2PC Authorization for Radio operating in Part 90 and RSS 119
Test Procedures:	ANSI/TIA-603-E, ANSI C63.26

### 1.2. RELATED SUBMITTAL(S)/GRANT(S)

None.

### 1.3. NORMATIVE REFERENCES

Publication	Year	Title
FCC CFR Parts 0-19, 80-End	2019	Code of Federal Regulations, Title 47 – Telecommunication
ANSI C63.4	2014	American National Standard for Methods of Measurement of Radio-Noise Emissions from Low-Voltage Electrical and Electronic Equipment in the Range of 9 KHz to 40 GHz
ANSI C63.26	2015	American National Standard for Compliance Testing of Transmitters Used in Licensed Radio Services
ANSI/TIA-603-E	2016	Land Mobile FM or PM Communications Equipment Measurement and Performance Standards
RSS-119, Issue 12	2015	Land Mobile and Fixed Equipment Operating in the Frequency Range 27.41-960 MHz
RSS-Gen, Issue 5	2018	General Requirements for Compliance of Radio Apparatus
ICES-003, Issue 6	2016 Updated April 2017	Information Technology Equipment (Including Digital Apparatus) — Limits and Methods of Measurement

**EXHIBIT 2. PERFORMANCE ASSESSMENT**

**2.1. CLIENT INFORMATION**

<b>Applicant</b>	
<b>Name:</b>	Futurecom Systems Group, ULC
<b>Address:</b>	3277 Langstaff Road Concord, ON Canada L4K 5P8
<b>Contact Person:</b>	Mr. Tony Bombera Phone #: 905 532 1114 Fax #: 905 660 6858 Email Address: tony.bombera@futurecom.com

<b>Manufacturer</b>	
<b>Name:</b>	Futurecom Systems Group, ULC
<b>Address:</b>	3277 Langstaff Road Concord, ON Canada L4K 5P8
<b>Contact Person:</b>	Mr. Tony Bombera Phone #: 905 532 1114 Fax #: 905 660 6858 Email Address: tony.bombera@futurecom.com

**2.2. EQUIPMENT UNDER TEST (EUT) INFORMATION**

The following information (with the exception of the Date of Receipt) has been supplied by the applicant.

<b>Brand Name:</b>	Futurecom Systems Group, ULC
<b>Product Name:</b>	DVRS Vehicular Repeater
<b>Model Name or Number:</b>	DVR-LX 700
<b>Serial Number:</b>	Preproduction
<b>Type of Equipment:</b>	Licensed Non-Broadcast Station Transmitter
<b>Power Supply Requirement:</b>	13.8 VDC
<b>Transmitting/Receiving Antenna Type:</b>	Non-integral
<b>Operational Description:</b>	The Futurecom DVRS Vehicular Repeater is designed to interface to a range of mobile radios. It permits expanded operation of portable radios. The MOBEXCOM DVR Vehicular Repeater communicates with the mobile radio using a serial data protocol.

**2.3. EUT'S TECHNICAL SPECIFICATIONS**

<b>Transmitter</b>	
Equipment Type:	Mobile
Intended Operating Environment:	<input checked="" type="checkbox"/> Commercial <input checked="" type="checkbox"/> Light Industry & Heavy Industry
Power Supply Requirement:	13.8 Vdc
RF Output Power Rating:	1 to 20 W
Operating Frequency Range:	764-776 MHz, 794-806 MHz
RF Output Impedance:	50 Ohms
Channel Spacing:	12.5 kHz & 25.0 kHz
Emission Designation:	11K0F3E, 16K0F3E, 7K30F1E, 8K10F1E
Oscillator Frequencies:	Digital signal frequencies: 32.768 kHz, 16.0 MHz, 29.4912 MHz, 144.0 MHz and 120 MHz  Analogue signal frequency: LO1: Rx Freq - 109.65 MHz (Rx), LO2: 107.85 MHz & LO3: Tx Freq + 110.51875 MHz  Reference Oscillator: 14.4 MHz
Antenna Connector Type:	TNC female

**2.4. LIST OF EUT'S PORTS**

Port Number	EUT's Port Description	Number of Identical Ports	Connector Type	Cable Type (Shielded/Non-shielded)
1	DC Input Port	1	Jack	Non-shielded
2	RF IN/OUT Port	2	TNC	Shielded
3	RS-232 Port	1	9 pin male circular	Non-shielded
4	Mobile Radio Port	1	20 pin male circular	Non-shielded
5	USB*	1	USB	Shielded

\* The USB port is a service port. It is only used during configuration/programming.

**2.5. ANCILLARY EQUIPMENT**

The EUT was tested while connected to the following representative configuration of ancillary equipment necessary to exercise the ports during tests:

None.

**EXHIBIT 3. EUT OPERATING CONDITIONS AND CONFIGURATIONS DURING TESTS**

**3.1. CLIMATE TEST CONDITIONS**

The climate conditions of the test environment are as follows:

Temperature:	21° C to 24° C
Humidity:	45 to 51%
Pressure:	102 kPa
Power input source:	13.8 VDC

**3.2. OPERATIONAL TEST CONDITIONS & ARRANGEMENT FOR TEST SIGNALS**

<b>Operating Modes:</b>	The transmitter was operated in a continuous transmission mode with the carrier modulated as specified in the Test Data.
<b>Special Test Software:</b>	Operating software provided by Futurecom for selecting operating channel frequency and power
<b>Special Hardware Used:</b>	N/A
<b>Transmitter Test Antenna:</b>	The EUT is tested with the transmitter antenna port terminated to a 50 Ω RF Load.

<b>Transmitter Test Signals</b>	
<b>Frequency Band(s):</b>	<ul style="list-style-type: none"> <li>▪ 764-776 MHz</li> <li>▪ 794-806 MHz</li> </ul>
<b>Frequency(ies) Tested:</b> (near top, near middle and near bottom in the frequency range of operation.)	<ul style="list-style-type: none"> <li>▪ 764 MHz, 770 MHz and 775 MHz</li> <li>▪ 794 MHz, 800 MHz and 805 MHz</li> </ul>
<b>Transmitter Wanted Output Test Signals:</b>	
<ul style="list-style-type: none"> <li>▪ RF Power Output (measured maximum output power):</li> <li>▪ Normal Test Modulation:</li> <li>▪ Modulating signal source:</li> </ul>	<p>20.56 W</p> <p>FM Data &amp; Voice</p> <p>external</p>

**EXHIBIT 4. SUMMARY OF TEST RESULTS**

**4.1. LOCATION OF TESTS**

All of the measurements described in this report were performed at Ultratech Group of Labs located in the city of Oakville, Province of Ontario, Canada.

- AC Power Line Conducted Emissions were performed in UltraTech's shielded room, 24'(L) by 16'(W) by 8'(H).
- Radiated Emissions were performed at the Ultratech's 3-10 TDK Semi-Anechoic Chamber situated in the Town of Oakville, province of Ontario. This test site been calibrated in accordance with ANSI C63.4, and found to be in compliance with the requirements of Sec. 2.948 of the FCC Rules. The descriptions and site measurement data of the Oakville 3-10 TDK Semi-Anechoic Chamber has been filed with ANAB File No.: AT-1945.

**4.2. APPLICABILITY & SUMMARY OF EMISSION TEST RESULTS**

FCC/RSS Section(s)	Test Requirements	Applicability (Yes/No)
90.541 & 2.1046 RSS-119 § 5.4	RF Power Output	Yes
1.1307, 1.1310, 2.1091 & 2.1093 RSS-Gen, §3.4 & RSS-102	RF Exposure Limit	N/A
90.539 & 2.1055 RSS-119 § 5.3	Frequency Stability	Yes
2.1047(a)	Audio Frequency Response	N/A
2.1047(b)	Modulation Limiting	N/A
2.1049 RSS-119 § 5.5	Occupied Bandwidth	N/A
90.543(a) RSS-119 § 5.8.9.1	Adjacent Channel Power	Yes
90.543(c), 2.1057 & 2.1051 RSS-119 § 5.8	Emission Limits - Spurious Emissions at Antenna Terminal	Yes
90.543(c), 2.1057 & 2.1053 RSS-119 § 5.8	Emission Limits - Field Strength of Spurious Emissions	Yes
ICES-003, Issue 6	Digital Apparatus -Radiated	Yes
ICES-003, Issue 6	Digital Apparatus -Conducted	Yes

N/A- Not applicable due to the nature of changes for this permissive change

**4.3. MODIFICATIONS INCORPORATED IN THE EUT FOR COMPLIANCE PURPOSES**

None.

**4.4. DEVIATION OF STANDARD TEST PROCEDURES**

None.

**ULTRATECH GROUP OF LABS**

3000 Bristol Circle, Oakville, Ontario, Canada L6H 6G4  
 Tel. #: 905-829-1570, Fax. #: 905-829-8050, Email: [vic@ultratech-labs.com](mailto:vic@ultratech-labs.com), Website: <http://www.ultratech-labs.com>

File #: 20FSG188\_FCC90R  
 March 13, 2020

All test results contained in this engineering test report are traceable to National Institute of Standards and Technology (NIST)



**EXHIBIT 5. TEST DATA**

**5.1. RF POWER OUTPUT [§§ 2.1046 & 90.541] [RSS-119 § 5.4]**

**5.1.1. Limits**

The transmitting power and antenna height of base, mobile, portable and control stations operating in the 769-775 MHz and 799-805 MHz frequency bands must not exceed the maximum limits in this section. Power limits are listed in effective radiated power (ERP).

- (a) The transmitting power and antenna height of base stations must not exceed the limits given in paragraph (a) of §90.635.
- (b) The transmitting power of a control station must not exceed 200 watts ERP.
- (c) The transmitting power of a mobile unit must not exceed 100 watts ERP.
- (d) The transmitting power of a portable (hand-held) unit must not exceed 3 watts ERP.
- (e) Transmitters operating on the narrowband low power channels listed in §90.531(b)(3) and (4), must not exceed 2 watts ERP.

[RSS-119 § 5.4]

The output power shall be within  $\pm$  1.0 dB of the manufacturer’s rated power.

The transmitter output power limits

**RSS-119 Table 2 – Transmitter Output Power**

Frequency Bands (MHz)	Transmitter Output Power (W)	
	Base/Fixed Equipment	Mobile Equipment
27.41-28 and 29.7-50	300	30
72-76	No limit	1
138-174	110	60
217-218 and 219-220	110	30*
220-222	See SRSP-512 for ERP limit	50
406.1-430 and 450-470	110	60
768-776 and 798-806	See SRSP-511 for ERP limit	30 3 W ERP for portable equipment
806-821/851-866 and 821-824/866-869	110	30
896-901/935-940	110	60
929-930/931-932	110	30
928-929/952-953 and 932-932.5/941-941.5	110	30
932.5-935/941.5-944	110	30

\*Equipment is generally authorized for effective radiated power (ERP) of less than 5 W.

**5.1.2. Method of Measurements**

TIA-603-E, ANSI C63.26

**5.1.3.**

**5.1.4. Test Equipment List**

Test Instruments	Manufacturer	Model No.	Serial No.	Frequency Range	Calibration Due Date
Power Meter	Hewlett Packard	436A	2101A11242	100 kHz sensor dependant	Jun 11, 2020
Power Sensor	Hewlett Packard	8481A	MY41090358	10 MHz – 18 GHz	Feb 20, 2020
Attenuator (30dB)	Weinschel	48-30-34	BM5354	DC – 18 GHz	Cal on use
Attenuator (10dB)	Weinschel	46-10-30	BL2618	DC – 18 GHz	Cal on use
DC Power Supply	HQ Power	PS613U	NSN	0 – 30V 3A	Cal on use
Multi-meter	Fluke	8842A	4142058	20mV - 1kV	Sep 5, 2020

**5.1.5. Test Arrangement**

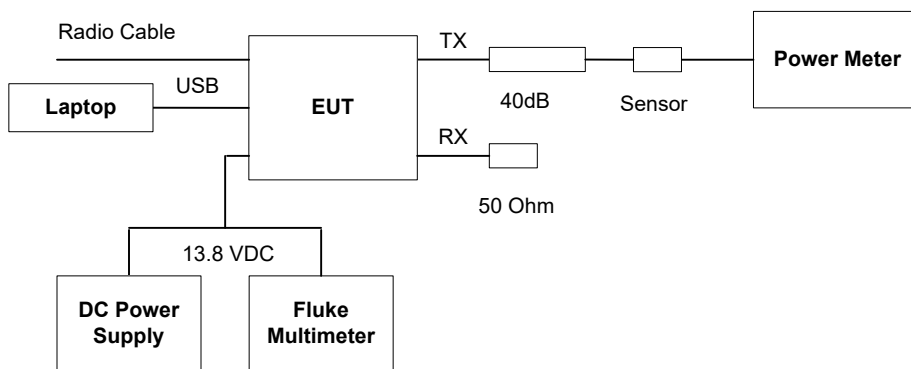

### 5.1.6. Test Data

#### Power setting High

Frequencies MHz	Channel Spacing KHz	Power Rating Watts	Power Rating dBm	Power dBm	Actual Power Watts
764.000	12.5	20.0	43.01	43.10	20.42
770.000	12.5	20.0	43.01	42.94	19.68
775.000	12.5	20.0	43.01	42.79	19.01
764.000	25	20.0	43.01	43.13	20.56
770.000	25	20.0	43.01	42.91	19.54
775.000	25	20.0	43.01	42.79	19.01
794.000	12.5	20.0	43.01	42.90	19.50
800.000	12.5	20.0	43.01	42.96	19.77
805.000	12.5	20.0	43.01	42.93	19.63
794.000	25	20.0	43.01	42.91	19.54
800.000	25	20.0	43.01	42.96	19.77
805.000	25	20.0	43.01	42.93	19.63

## 5.2. TRANSMITTER SPURIOUS/HARMONIC RADIATED EMISSIONS [§ 90.543(c) & (e)] [RSS-119 §§ 5.5 & 5.8]

### 5.2.1. Limits

#### § 90.543

c) *Out-of-band emission limit.* On any frequency outside of the frequency ranges covered by the ACP tables in this section, the power of any emission must be reduced below the mean output power (P) by at least  $43 + 10\log(P)$  dB measured in a 100 kHz bandwidth for frequencies less than 1 GHz, and in a 1 MHz bandwidth for frequencies greater than 1 GHz.

- (e) For operations in the 758-768 MHz and the 788-798 MHz bands, the power of any emission outside the licensee's frequency band(s) of operation shall be attenuated below the transmitter power (P) within the licensed band(s) of operation, measured in watts, in accordance with the following:
- (1) On all frequencies between 769-775 MHz and 799-805 MHz, by a factor not less than  $76 + 10 \log(P)$  dB in a 6.25 kHz band segment, for base and fixed stations.
  - (2) On all frequencies between 769-775 MHz and 799-805 MHz, by a factor not less than  $65 + 10 \log(P)$  dB in a 6.25 kHz band segment, for mobile and portable stations.
  - (3) On any frequency between 775-788 MHz, above 805 MHz, and below 758 MHz, by at least  $43 + 10 \log(P)$  dB.
  - (4) Compliance with the provisions of paragraphs (e)(1) and (2) of this section is based on the use of measurement instrumentation such that the reading taken with any resolution bandwidth setting should be adjusted to indicate spectral energy in a 6.25 kHz segment.
  - (5) Compliance with the provisions of paragraph (e)(3) of this section is based on the use of measurement instrumentation employing a resolution bandwidth of 100 kHz or greater. However, in the 100 kHz bands immediately outside and adjacent to the frequency block, a resolution bandwidth of 30 kHz may be employed.
- (f) For operations in the 758-775 MHz and 788-805 MHz bands, all emissions including harmonics in the band 1559-1610 MHz shall be limited to  $-70$  dBW/MHz equivalent isotropically radiated power (EIRP) for wideband signals, and  $-80$  dBW EIRP for discrete emissions of less than 700 Hz bandwidth. For the purpose of equipment authorization, a transmitter shall be tested with an antenna that is representative of the type that will be used with the equipment in normal operation.

[RSS-119 §§ 5.5 & 5.8]

On any frequency outside of the ranges specified in the ACP tables 13 to 16, the power of any emission shall be attenuated below the mean output power P (dBW) by at least  $43 + 10 \log_{10}(p)$ , measured in a 100 kHz bandwidth for frequencies less than or equal to 1 GHz, and in a 1 MHz bandwidth for frequencies greater than 1 GHz.

In addition, for operations in the bands 768-776 MHz and 798-806 MHz, all emissions (including harmonics in the band 1559-1610 MHz), shall not exceed:

$-70$  dBW/MHz equivalent isotropically radiated power (e.i.r.p.) for wideband emissions, and  $-80$  dBW/kHz e.i.r.p. for discrete emissions of less than 700 Hz bandwidth.

**5.2.2. Method of Measurements**

TIA-603-E / ANSI C63.26

**5.2.3. Test Equipment list**

Test Instruments	Manufacturer	Model No.	Serial No.	Frequency Range	Calibration Due Date
EMI Receiver	Rohde & Schwarz	ESU40	100037	20Hz–40 GHz	Mar 15, 2020
Spectrum Analyzer	Rohde & Schwarz	FSU26	200946	20Hz–26.5 GHz	Jul 25, 2020
RF Amplifier	Com-Power	PAM-0118A	551052	0.5 – 18 GHz	Jul 24, 2020
RF Amplifier	Hewlett Packard	8449B	3008A00769	1 – 26.5 GHz	Jan 7, 2021
Biconilog	Emco	3142B	1575	26-2000 MHz	May 10, 2020
Horn Antenna	Emco	3155	6570	1 – 18 GHz	Oct 11, 2020
DC Power Supply	HQ Power	PS613U	NSN	0 – 30V 3A	Cal on use
Multi-meter	Fluke	8842A	4142058	20mV - 1kV	Sep 5, 2020
High Pass Filter	K & L	11SH10-1500/T8000	2	Cut off 900 MHz	Cal on use
Signal Generator	Agilent	E8241A	US42110625	250kHz-20GHz	Oct 12, 2020
Horn Antenna	Emco	3115	5061	1 – 18 GHz	Apr 20, 2020

### 5.2.4. Test Arrangement

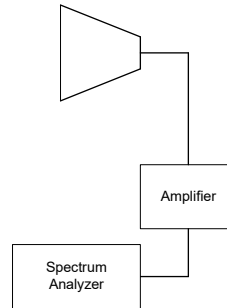
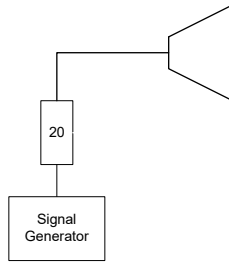
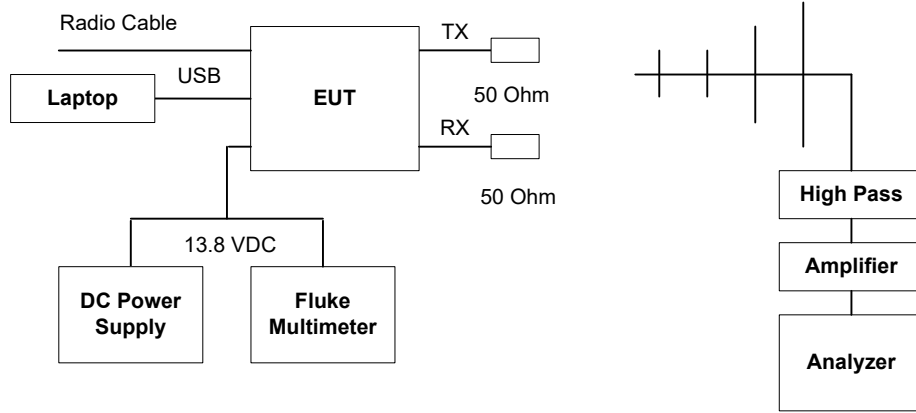

Test Data

**Remarks:**

- FCC 90.543(e) is not applicable for this device, transmit signals are not wideband or discrete signals.
- The rf spurious/harmonic emission characteristics between 2 different channel spacing operations and different modulations (voice/digital) are identical. Therefore, the following radiated emissions were performed on the radio set with 12.5 kHz channel spacing operation.
- The radiated emissions were performed at 3 meters distance. At its maximum power for worst case.
- The emissions were scanned from 30 MHz to 9 GHz; all spurious emissions that are in excess of 20dB below the specified limit shall be recorded.

**5.2.4.1. 764 - 776 MHz Band**

<b>Carrier Frequency:</b>		764 MHz				
<b>Limit:</b>		-13 dBm				
Frequency (MHz)	E-Field (dBµV/m)	EMI Detector (Peak/QP)	Antenna Polarization (H/V)	ERP (dBm)	Limit (dBm)	Margin (dB)
30 - 9000	*	Peak	H/V	*	-13	*

\* All harmonics and spurious emissions are more than 20 dB below the specified attenuation limit.

<b>Carrier Frequency:</b>		770 MHz				
<b>Limit:</b>		-13 dBm				
Frequency (MHz)	E-Field (dBµV/m)	EMI Detector (Peak/QP)	Antenna Polarization (H/V)	ERP (dBm)	Limit (dBm)	Margin (dB)
30 - 9000	*	Peak	H/V	*	-13	*

\* All harmonics and spurious emissions are more than 20 dB below the specified attenuation limit.

<b>Carrier Frequency:</b>		775 MHz				
<b>Limit:</b>		-13 dBm				
Frequency (MHz)	E-Field (dBµV/m)	EMI Detector (Peak/QP)	Antenna Polarization (H/V)	ERP (dBm)	Limit (dBm)	Margin (dB)
30 - 9000	*	Peak	H/V	*	-13	*

\* All harmonics and spurious emissions are more than 20 dB below the specified attenuation limit.

**5.2.4.2. 794 - 806 MHz Band**

<b>Carrier Frequency:</b>		794 MHz				
<b>Limit:</b>		-13 dBm				
Frequency (MHz)	E-Field (dB $\mu$ V/m)	EMI Detector (Peak/QP)	Antenna Polarization (H/V)	ERP (dBm)	Limit (dBm)	Margin (dB)
30 - 9000	*	Peak	H/V	*	-13	*

\* All harmonics and spurious emissions are more than 20 dB below the specified attenuation limit.

<b>Carrier Frequency:</b>		800 MHz				
<b>Limit:</b>		-13 dBm				
Frequency (MHz)	E-Field (dB $\mu$ V/m)	EMI Detector (Peak/QP)	Antenna Polarization (H/V)	ERP (dBm)	Limit (dBm)	Margin (dB)
30 - 9000	*	Peak	H/V	*	-13	*

\* All harmonics and spurious emissions are more than 20 dB below the specified attenuation limit.

<b>Carrier Frequency:</b>		805 MHz				
<b>Limit:</b>		-13 dBm				
Frequency (MHz)	E-Field (dB $\mu$ V/m)	EMI Detector (Peak/QP)	Antenna Polarization (H/V)	ERP (dBm)	Limit (dBm)	Margin (dB)
30 - 9000	*	Peak	H/V	*	-13	*

\* All harmonics and spurious emissions are more than 20 dB below the specified attenuation limit.



**5.3. RADIATED EMISSIONS FROM UNINTENTIONAL RADIATORS [ICES-003]**

**5.3.1. Limits**

The equipment shall meet the limits of the following table:

Frequency of emission (MHz)	Class B Limits	
	(dB $\mu$ V/m at 3 m)	(dB $\mu$ V/m at 10 m)
30 – 88	40.0	29.5
88 – 216	43.5	33.1
216 – 960	46.0	35.6
Above 960	54.0	43.5

**5.3.2. Method of Measurements**

Refer to Ultratech Test Procedures ULTR-P001-2004 & ANSI C63.4 for method of measurements.

**5.3.3. Test Equipment list**

Test Instruments	Manufacturer	Model No.	Serial No.	Frequency Range	Calibration Due Date
EMI Receiver	Rohde & Schwarz	ESU40	100037	20Hz–40 GHz	Mar 15, 2020
RF Amplifier	Com-Power	PAM-0118A	551052	0.5 – 18 GHz	Jul 24, 2020
Biconilog	Emco	3142B	1575	26-2000 MHz	May 10, 2020
Horn Antenna	Emco	3115	5061	1 – 18 GHz	Apr 20, 2020
DC Power Supply	HQ Power	PS613U	NSN	0 – 30V 3A	Cal on use
Multi-meter	Fluke	8842A	4142058	20mV - 1kV	Sep 5, 2020

5.3.4. Test Arrangement

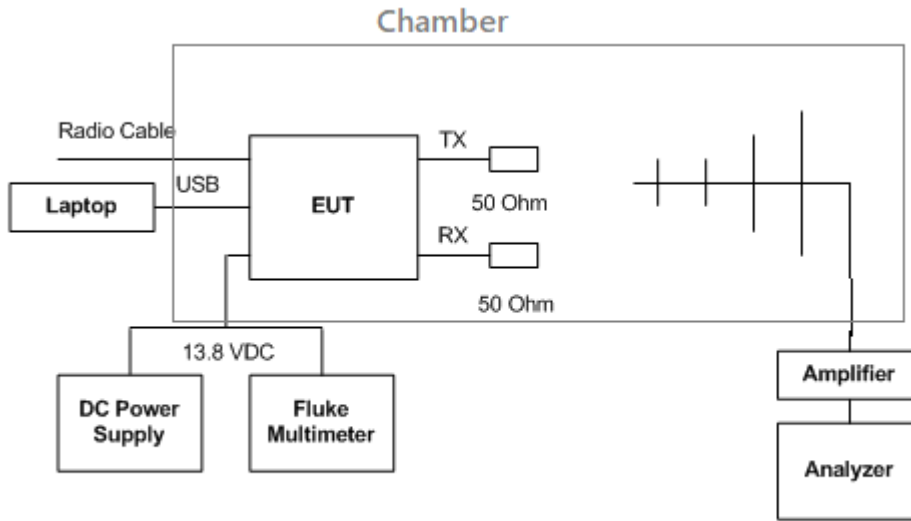

5.3.5. Test Data

The emissions were scanned from 30 MHz to 5.0 GHz. All emissions found above than 20 dB below the permissible limits were recorded

FREQUENCY (MHz)	RF LEVEL (dBuV/m)	DETECTOR USED (PEAK/QP)	ANTENNA PLANE (H/V)	LIMIT (dBuV/m)	MARGIN (dB)	PASS/ FAIL
30.1	34.72	PEAK	V	40	-5.28	PASS
30.1	25	PEAK	H	40	-15	PASS
52.5	33.9	QP	V	40	-6.1	PASS
52.5	30.01	PEAK	H	40	-9.99	PASS
120.16	37.7	PEAK	V	43.5	-5.8	PASS
120.16	29.25	PEAK	H	43.5	-14.25	PASS
864.75	39.53	PEAK	V	46	-6.47	PASS
864.75	40.78	PEAK	H	46	-5.22	PASS
925.38	38.66	PEAK	V	46	-7.34	PASS
925.38	35.59	PEAK	H	46	-10.41	PASS
972	39.15	PEAK	V	54	-14.85	PASS
972	35.17	PEAK	H	54	-18.83	PASS
996.9	38.66	PEAK	V	54	-15.34	PASS
996.9	35.9	PEAK	H	54	-18.1	PASS
1186	37.84	PEAK	V	54	-16.16	PASS
1186	40.16	PEAK	H	54	-13.84	PASS

**EXHIBIT 6. MEASUREMENT UNCERTAINTY**

The measurement uncertainties stated were calculated in accordance with the requirements of CISPR 16-4-2 @ IEC:2003 and JCGM 100:2008 (GUM 1995) – Guide to the Expression of Uncertainty in Measurement.

**6.1. RADIATED EMISSION MEASUREMENT UNCERTAINTY**

	<b>Radiated Emission Measurement Uncertainty @ 3m, Horizontal (30-1000 MHz):</b>	<b>Measured (dB)</b>	<b>Limit (dB)</b>
<b>u<sub>c</sub></b>	<b>Combined standard uncertainty:</b> $u_c(y) = \sqrt{\sum_{i=1}^m u_i^2(y)}$	<b>± 2.39</b>	<b>± 2.6</b>
<b>U</b>	<b>Expanded uncertainty U:</b> $U = 2u_c(y)$	<b>± 4.79</b>	<b>± 5.2</b>

	<b>Radiated Emission Measurement Uncertainty @ 3m, Vertical (30-1000 MHz):</b>	<b>Measured (dB)</b>	<b>Limit (dB)</b>
<b>u<sub>c</sub></b>	<b>Combined standard uncertainty:</b> $u_c(y) = \sqrt{\sum_{i=1}^m u_i^2(y)}$	<b>± 2.39</b>	<b>± 2.6</b>
<b>U</b>	<b>Expanded uncertainty U:</b> $U = 2u_c(y)$	<b>± 4.78</b>	<b>± 5.2</b>

	<b>Radiated Emission Measurement Uncertainty @ 3 m, Horizontal &amp; Vertical (1 – 18 GHz):</b>	<b>Measured (dB)</b>	<b>Limit (dB)</b>
<b>u<sub>c</sub></b>	<b>Combined standard uncertainty:</b> $u_c(y) = \sqrt{\sum_{i=1}^m u_i^2(y)}$	<b>± 1.87</b>	<b>Under consideration</b>
<b>U</b>	<b>Expanded uncertainty U:</b> $U = 2u_c(y)$	<b>± 3.75</b>	<b>Under consideration</b>