

 MOTOROLA SOLUTIONS	 MS ISO/IEC 17025 TESTING SAMM No.0826
---	---

DECLARATION OF COMPLIANCE: MPE ASSESSMENT Part 1 of 3

Motorola Solutions EME Test Laboratory Motorola Solutions Malaysia Sdn Bhd (Innoplex) Plot 2A, Medan Bayan Lepas, Mukim 12 SWD 11900 Bayan Lepas Penang, Malaysia.	Date of Report: 9/27/2018 Report Revision: A
--	---

Responsible Engineer: Report author: Date(s) Tested: Manufacturer: Date submitted for test: DUT Description: Test TX mode(s): Max. Power output: TX Frequency Bands: Signaling type: Model(s) Tested: Model(s) Certified: Serial Number(s): Classification: FCC ID:	Saw Sun Hock (EME Engineer) Saw Sun Hock (EME Engineer) 2/17/2017-3/17/2017; 7/27/2018-9/26/2018 Futurecom Systems Group 01/13/2017 DVR 700 (764-806 MHz), Digital Vehicular Repeater Companion Mobile: APX8500 HP mobile All Bands (VHF, UHF, 7/800) CW (for FM), 802.11 b/g/n (for WLAN 2.4GHz), 802.11 a/n/ac (for WLAN 5GHz) DVR: 5W (100% duty cycle) Companion Mobile: 50% duty cycle, PTT with below maximum output power 120W (136-174 MHz), 120W (380-484 MHz), 48W (485-512 MHz), 30W (512-520 MHz), 36W (764-805 MHz), 42W (806-870 MHz); 63.1 mW (WLAN 2.4 GHz 802.11b), 25 mW (WLAN 2.4 GHz 802.11g/n) ; 31.6 mW (WLAN 5 GHz 802.11 a/n/ac) DVR: 764-776 MHz, 794-806 MHz Companion Mobile: 136-174 MHz; 380-520 MHz; 764-805 MHz; 806-870 MHz; WLAN 2400-2483.5 MHz; WLAN 5180-5825 MHz FM, TDMA, 802.11b/g/n (WLAN); 802.11 a/n/ac (WLAN 5 GHz) DVR: MOBEXCOM DVRS 700 (DQPM DVRS7000P) Companion Mobile: M37TXS9PW1AN (HUW1001A) MOBEXCOM DVRS 700 (DQPM DVRS7000P) 16092663 (DVR) , 681P3A0098 & 681P3A0116 (Companion Mobile) Occupational/Controlled Environment DVR: LO6-DVRS700 769-775 MHz, 799-806 MHz Companion Mobile: AZ492FT7118 150.8-173.4 MHz, 406.1-512 MHz, 769-775 MHz, 799-824 MHz, 851-869 MHz, 2412-2462 MHz, 5180-5825 MHz
--	--

The MPE results clearly demonstrate compliance with FCC Occupational/Controlled RF Exposure limits. FCC rules require compliance for Passengers and Bystanders to the FCC General Population/Uncontrolled limits.

Based on the information and the testing results provided herein, the undersigned certifies that when used as stated in the operating instructions supplied, said product complies with the national and international reference standards and guidelines listed in section 3.0 of this report. This report shall not be reproduced without written approval from an officially designated representative of the Motorola Solutions Inc. EME Laboratory. I attest to the accuracy of the data and assume full responsibility for the completeness of these measurements. This reporting format is consistent with the suggested guidelines of the TIA TSB-159 April 2006. The results and statements contained in this report pertain only to the device(s) evaluated herein.

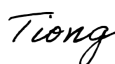
 Tiong Nguk Ing Deputy Technical Manager (Approved Signatory) Approval Date: 10/31/2018	
--	--

Document Revision History

Date	Revision	Comments
9/27/2018	A	Initial release

Table of Contents

Part 1 of 3

1.0 Introduction..... 5

2.0 FCC MPE Summary 5

3.0 Abbreviations / Definitions..... 6

4.0 Referenced Standards and Guidelines 6

5.0 Power Density Limits 7

6.0 N_c Test Channels..... 8

7.0 Measurement Equipment 8

8.0 Measurement System Uncertainty Levels 9

9.0 Product and System Description..... 9

10.0 Additional Options and Accessories..... 11

11.0 Test Set-Up Description..... 11

12.0 Method of Measurement for DVR with trunk mounted antenna(s)..... 11

 12.1 External/Bystander vehicle MPE measurements 11

 12.2 Internal/Passenger vehicle MPE measurements..... 12

13.0 Method of Measurement Companion Mobile with roof mounted antenna(s) 12

 13.1 External/Bystander vehicle MPE measurements 13

 13.2 Internal/Passenger vehicle MPE measurements..... 13

14.0 MPE Variability Requirement for External/Bystander vehicle MPE measurement..... 14

15.0 MPE Calculations 14

16.0 Antenna Summary 15

17.0 Test Results Summary 18

 17.1 MPE Test Results Summary for DVR and Companion Mobile (LMR) 18

 17.2 MPE Test Results for Companion Mobile (WLAN)..... 19

 17.3 Simultaneous Transmission..... 21

18.0 Conclusion 24

19.0 User Instructions Considerations 25

Appendix A - Antenna Locations, Test Distances, and Cable Losses..... 26

Appendix B - Probe Calibration Certificates 33

Appendix C - Photos of Assessed Antennas..... 39

Part 2 of 3

Appendices

Appendix D – MPE Test Results Summary for DVR 700 2
Appendix E – MPE Test Results Summary for Companion Mobile LMR VHF 6
Appendix F – MPE Test Results Summary for Companion Mobile LMR UHF1 37
Appendix G – MPE Test Results Summary for Companion Mobile LMR UHF2 55
Appendix H – MPE Test Results Summary for Companion Mobile LMR 7/800 72

Part 3 of 3

Appendices

Appendix I – MPE Measurement Results for DVR 700..... 2
Appendix J – MPE Measurement Results for Companion Mobile LMR VHF 6
Appendix K – MPE Measurement Results for Companion Mobile LMR UHF1 65
Appendix L – MPE Measurement Results for Companion Mobile LMR UHF2 97
Appendix M - MPE Measurement Results for Companion Mobile LMR 7/800 131

1.0 Introduction

This report details the test setup, test equipment and test results of Maximum Permissible Exposure (MPE) performed at Motorola Solutions’ outside test site for DVRS 700 (FCC ID: LO6-DVRS700) and Companion Mobile radio (FCC ID: AZ492FT7118).

2.0 FCC MPE Summary

Table 1

DVRS 700 (FCC ID: LO6-DVRS700) Trunk Mounted Antenna					
Equipment Class	Frequency Band (MHz)	Passenger		Bystander	
		Power Density (mw/cm ²)	Highest % of Limit	Power Density (mw/cm ²)	Highest % of Limit
TNB	769-775 MHz; 799-806 MHz	0.038	7.3%	0.020	3.9%
Companion Mobile APX8500 (FCC ID: AZ492FT7118) Roof Mounted Antenna					
Equipment Class	Frequency Band (MHz)	Passenger		Bystander	
		Power Density (mw/cm ²)	Highest % of Limit	Power Density (mw/cm ²)	Highest % of Limit
TNB	VHF (150.8 – 173.4 MHz)	0.424	212.1%	0.172	86.2%
	UHF1 (406.1-470 MHz)	0.123	45.4%	0.107	39.3%
	UHF2 (450-512 MHz)	0.111	37.1%	0.104	34.6%
	7/800 (769-775 MHz; 799-824 MHz;851-869 MHz)	0.043	8.4%	0.032	5.9%
DTS	WLAN (2412-2462 MHz)	0.030	3.01%	0.030	3.01%
NII	WLAN (5180 - 5825 MHz)	0.009	0.93%	0.009	0.93%
Simultaneous Transmissions					
Simultaneous Transmissions conditions		Passenger		Bystander	
		Highest Combine % of limit		Highest Combine % of limit	
DVRS 700 + WLAN + VHF		222.4%		90.0%	
DVRS 700 + WLAN + UHF1		55.7%		43.1%	
DVRS 700 + WLAN + UHF2		47.4%		38.4%	
DVRS 700 + WLAN + 7/800		18.7%		9.8%	

3.0 Abbreviations / Definitions

CNR: Calibration Not Required
CW: Continuous Wave
DUT: Device Under Test
EME: Electromagnetic Energy
FM: Frequency Modulation
MPE: Maximum Permissible Exposure
GPS: Global Positioning System
LMR: Land Mobile Radio
SAR: Specific Absorption Rate
NA: Not Applicable
BS: Bystander
PB: Passenger Back seat
PF: Passenger Front seat
PTT: Push to Talk
WLAN: Wireless Local Area Network
TDMA: Time Division Multiple Access

4.0 Referenced Standards and Guidelines

This product is designed to comply with the following applicable national and international standards and guidelines.

- United States Federal Communications Commission, Code of Federal Regulations; Rule Part 47CFR § 1.1310, § 2.1091 (d) for RF Exposure.
- Federal Communications Commission, “Evaluating Compliance with FCC Guidelines for Human Exposure to Radio frequency Electromagnetic Fields”, OET Bulletin 65 (Edition 97-01), FCC, Washington, D.C.: August 1997.
- American National Standards Institute (ANSI) / Institute of Electrical and Electronics Engineers (IEEE) C95. 1-1999
- American National Standards Institute (ANSI) / Institute of Electrical and Electronics Engineers (IEEE) C95. 1-1992. Specific to FCC rules and regulations.
- Institute of Electrical and Electronics Engineers (IEEE) C95.3-2002
- International Commission on Non-Ionizing Radiation Protection (ICNIRP) 1998
- Ministry of Health (Canada) Safety Code 6 (2015), Limits of Human Exposure to Radio frequency Electromagnetic Fields in the Frequency Range from 3 kHz to 300 GHz
- RSS-102 (Issue 5) – Radio Frequency (RF) Exposure Compliance of Radio communication Apparatus (All Frequency Bands)
- FCC KDB – 447498 D01 General RF Exposure Guidance v06
- FCC KDB – 865664 D01 SAR Measurement 100 MHz to 6 GHz v01r04
- FCC KDB – 865664 D02 RF Exposure Reporting v01r02

5.0 Power Density Limits

Table 2 – Occupational / Controlled Exposure Limits

Frequency Range (MHz)	FCC OET Bulletin 65	ICNIRP	IEEE C95.1 1992/1999	IEEE C95.1 2005	RSS-102 Issue 5 2015
	mW/cm ²	W/m ²	mW/cm ²	W/m ²	W/m ²
10 – 20					10.0
20 – 48					44.72 / $f^{0.5}$
30 – 300	1.0				
48 – 100					6.455
10 – 400		10.0			
100 – 300			1.0	10.0	
100 – 6,000					0.6455 $f^{0.5}$
300 – 1,500	f/300				
300 – 3,000			f/300	f/30	
400 – 2,000		f/40			
1,500 – 15,000					
1,500 – 100,000	5.0				
2,000 – 300,000		50.0			
3,000 – 300,000			10.0	100.0	
6,000 – 15,000					50.0
15000 – 150,000					50.0
150000 – 300,000					3.33 × 10 ⁻⁴ f

Table 3 – General Population / Uncontrolled Exposure Limits

Frequency Range (MHz)	FCC OET Bulletin 65	ICNIRP	IEEE C95.1 1992/1999	IEEE C95.1 2005	RSS-102 Issue 5 2015
	mW/cm ²	W/m ²	mW/cm ²	W/m ²	W/m ²
10 – 20					2.0
20 – 48					8.944 / $f^{0.5}$
30 – 300	0.2				
48 – 300					1.291
10 – 400		2.0			
100 – 300			0.2		
100 – 400				2.0	
300 – 1,500	f/1,500				
300 – 6000					0.02619 $f^{0.6834}$
400 – 2,000		f/200		f/200	
300 – 15,000			f/1,500		
1,500 – 15,000					

Table 3 Continued – General Population / Uncontrolled Exposure Limits

Frequency Range (MHz)	FCC OET Bulletin 65	ICNIRP	IEEE C95.1 1992/1999	IEEE C95.1 2005	RSS-102 Issue 5 2015
	mW/cm ²	W/m ²	mW/cm ²	W/m ²	W/m ²
1,500 – 100,000	1.0				
2,000 – 100,000				10.0	
2,000 – 300,000		10.0			
6,000 – 15,000					10.0
15,000 – 150,000					10.0
150,000 – 300,000					$6.67 \times 10^{-5} f$

6.0 N_c Test Channels

The number of test channels is determined by using Equation 1 below. This equation is available in FCC’s KDB 447498. The test channels are appropriately spaced across the antenna’s frequency range.

Equation 1 – Number of test channels

$$N_c = \text{Round} \{ [100(f_{\text{high}} - f_{\text{low}})/f_c]^{0.5} \times (f_c / 100)^{0.2} \}$$

where *N_c* is the number of test channels, *f_{high}* and *f_{low}* are the highest and lowest frequencies within the transmission band, *f_c* is the mid-band frequency, and frequencies are in MHz.

7.0 Measurement Equipment

Table 4 – Equipment

Equipment Type	Model #	SN	Calibration Date	Calibration Due Date
Automobile	Volvo 240-1988	NA	NA	NA
Survey Meter	ETS Model HI-2200	00086316		
Probe – E-Field	ETS Model E100	00206767	7/2/2018	7/2/2019
Probe – H-Field	ETS Model H200	00206937		

E-field measurements are in mW/cm².

H field measurements are in A/m.

8.0 Measurement System Uncertainty Levels

Table 5 – Uncertainty Budget for Near Field Probe Measurements

	Tol. (± %)	Prob. Dist.	Divisor	u_i (±%)		v_i
Measurement System						
Probe Calibration	7.1	N	1.00	7.1	50.4	∞
Survey Meter Calibration	0.0	N	1.00	0.0	0.0	∞
Hemispherical Isotropy	8.0	R	1.73	4.6	21.33	∞
Linearity	5.0	R	1.73	2.9	8.33	∞
Pulse Response	1.0	R	1.73	0.6	0.33	∞
RF Ambient Noise	3.0	R	1.73	1.7	3.00	∞
RF Reflections	8.0	R	1.73	4.6	21.33	∞
Probe Positioning	10.0	R	1.73	5.8	33.333	∞
Test sample Related					0.00	
Antenna Positioning	3.0	N	1.00	3.0	9.0	∞
Power drift	5.0	R	1.73	2.9	8.33	∞
Bystander measurement uncertainty	4.8	N	1.00	4.8	23.04	∞
Passenger measurement uncertainty	8.1	N	1.00	8.1	65.61	∞
Combined Standard Uncertainty		RSS		15.6	15.6	∞
Expanded Uncertainty (95% CONFIDENCE LEVEL)		$k=2$		31	31	

9.0 Product and System Description

MOBEXCOM DVRS 700 (FCC ID: LO6-DVRS700) is a Digital Vehicular Repeater (DVR) manufactured by Futurecom System Group. At standalone the DVR operates at a maximum power up to 20W, but when the DVR is interfaced to the APX8500 High Power Mobile radio, the maximum power is 5W as listed in Table 6. For more detailed information refer to the Product Safety and RF Energy Exposure Booklet for DVRS.

Companion mobile APX8500 HP (FCC ID: AZ492FT7118) operate in the LMR bands using either frequency modulation (FM) with 100% transmit duty cycle or TDMA signals with maximum of 50% transmit duty cycle. For conservative assessment, FM signal was tested.

Table 6 – Bands, Duty Cycle and Maximum power

Devices	Bands (MHz)	Duty Cycle (%)	Max power (W)	
DVR 700 (FCC ID:LO6-DVRS700)	764-776 ; 794-806	100% (Repeater)	5	
Companion Mobile APX8500 HP All bands (FCC ID: AZ492FT7118)	136-174 (VHF band)	50% (PTT)	120	
	380- 470 (UHF1) 450- 520 (UHF2)	380–484	50% (PTT)	120
		485-512	50% (PTT)	48
		512-520	50% (PTT)	30
	764-805 ; 806-870 (7/800 band)	764-805	50% (PTT)	36
		806-870	50% (PTT)	42
	2400 – 2483.5 (802.11b/g/n)	100%	0.0631 (802.11 b) 0.025 (802.11 g) 0.025 (802.11 n)	
5180-5825 (802.11 a/n/ac)	100%	0.0316		

In addition to standalone operation, is capable of interfacing to a Companion mobile radio using serial data protocol for audio and control. The DVRS can operate in the following modes: OFF mode– DVRS repeat is not required; LOCAL mode–with portable-to-portable repeat and network monitoring capabilities; and SYSTEM mode – outbound calls received by mobile radio are repeated by DVRS. Inbound calls received by DVRS are repeated locally (portable-to-portable) as well as to the system users (by keying up the mobile radio).

This test report covers the RF exposure performance of the DVR FCC ID: LO6-DVRS700 interfaced with, and transmitting simultaneously with Companion Mobile radio FCC ID: AZ492FT7118. DVR operate in repeater; transmit with duty cycle up to 100%. A duty factor of 50% applies for Companion mobile with PTT operating mode.

Companion mobile can transmitting only one LMR band at once. Table 7 lists all the simultaneous transmission conditions. LMR bands can transmit simultaneously with WLAN 2.4 GHz or WLAN 5 GHz. WLAN 2.4 GHz and WLAN 5 GHz cannot transmit at the same time.

Table 7 – Simultaneous transmission conditions

Simultaneous transmission conditions	DVRS 700	Companion Mobile APX8500 All bands (VHF, UHF, 7/800)				
	764-776 MHz; 794-806 MHz	WLAN	VHF [136-174 MHz]	UHF1 [380-470 MHz]	UHF2 [450-520 MHz]	7/800 [764-805 MHz; 806-870 MHz]
DVRS 700 + WLAN + VHF	x	x	x			
DVRS 700 + WLAN + UHF1	x	x		x		
DVRS 700 + WLAN + UHF2	x	x			x	
DVRS 700 + WLAN + 7/800	x	x				x

x: Simultaneous transmitting antennas

This device will be marketed to and used by employees solely for work-related operations. User training is the responsibility of these organizations. The Product Safety and RF Energy Exposure Booklet for Digital Vehicular Repeater Systems (DVRS) contains all the information necessary to inform the organization and its employees in safe usage and for creating training materials or conducting instructional sessions for those employees.

Accordingly this product is classified as Occupational/Controlled Exposure. However, in accordance with FCC requirements, the passengers inside the vehicle and the bystanders external to the vehicle are evaluated to the General Population/Uncontrolled Exposure Limits.

(Note that “Bystanders” as used herein are people other than operator)

10.0 Additional Options and Accessories

Not available.

11.0 Test Set-Up Description

Assessments were performed with DVR and Companion mobile radio installed in the test vehicle, at the specified distances and test locations indicated in sections 12.0, 13.0 and Appendix A.

All antennas described in Table 8 were considered in order to develop the test plan for this product. Antennas were installed and tested per their appropriate mount locations (Roof / Trunk) and defined test channels. The DVR antenna mounted at center of the trunk (for external/bystander measurement) or toward the center of the trunk at a minimum 85 cm from backseat passenger (for Internal/passenger measurement), and the Companion mobile antennas are mounted at the side of the roof (20 cm from the center of the roof).

The system was tested using a low-loss 16’ Teflon RG58A/U cable attaching the radio to the transmit antenna. This cable is shorter and lower attenuation than the 17’ RG58A/U cables supplied in the customer kits for connecting the radio to the transmit antenna. The cable used in the test setup also has lower attenuation over the test frequency range than the cable provided in the customer kits. The use of a shorter cable with lower attenuation in the test setup ensures that the test data is more conservative with regards to the actual installation. Cable losses are reported in Appendix A.

12.0 Method of Measurement for DVR with trunk mounted antenna(s)

12.1 External/Bystander vehicle MPE measurements

Initially the DVR antenna is located at the center of the trunk. Refer to Appendix A for antenna location and distance.

MPE measurements for bystander (BS) conditions are determined by taking the average of (10) measurements in a 2 m vertical line for each of the (5) bystander test locations indicated in Appendix A with 20 cm height increments, with the distance of 90cm from the test vehicle’s body, as stated in the user manual. The measurement probe is positioned orthogonal to antenna (typically parallel to ground with a vertically mounted antenna) and aimed directly at the antenna’s axis. These measurements are representative of persons other than the operator standing next to the vehicle.

12.2 Internal/Passenger vehicle MPE measurements

The DVR antenna is located toward the center of the trunk at a minimum 85 cm from backseat passenger. Refer to Appendix A for antenna location and distance.

MPE measurements for passenger front seat (PF) and backseat (PB) conditions are determined by taking the average of the (3) measurements (Head, Chest, and Lower Trunk) inside the vehicle for both the front and back seats.

The backseat is a bench seat and therefore each position (Head, Chest & Lower Trunk) were scanned across (horizontally) the seat starting from the middle of the seat to the edge of the seat stopping 20 cm from the vehicle door. Similar process was used in the front bucket seat.

The probe handle is oriented parallel (horizontal) to the ground and pointed towards the back of the vehicle. The probe handle is not oriented normal to the seat surface. The probe head (incorporating the field sensors) is scanned continuously (using the max-hold function available in the meter) along three test axes which are parallel to the seat angle (intended as the line determined by the intersection of the plane of the seat and the plane of the backrest) and are 20 cm from the seat surface. One test axis is at the Head height, another is at the Chest height, and another is at the Lower Trunk height. The maximum field level value recorded for each test axis is logged. The MPE is determined by averaging these three maximum values regardless of the geometrical location where they were observed. For instance, the locations of the three maxima may lie on different vertical (relative to ground) lines.

This approach leads to results that are representative of the exposure of vehicle occupants since it is based on an average across the body portions closest to the antenna for trunk mount positions, and is conservatively biased because the highest results for each test axis are combined, e.g. the highest head exposure could be in the middle of the seat while the highest lower trunk exposure could be closer to the door.

13.0 Method of Measurement Companion Mobile with roof mounted antenna(s)

The installation requirements for this radio indicate that in multiple single-band antenna configurations the antennas should be installed along a transverse line bisecting the roof, with one of the antennas in the center and the remaining two at 8" (20 cm) on each side. We tested all the antennas at one of the lateral positions (8" from the center along the mentioned bisecting line) in order to be closer to the edge of the roof. Additional measurements with antennas placed in the center of the roof are not needed because that placement would increase the distance to bystanders.

13.1 External/Bystander vehicle MPE measurements

Antenna is located at the side of the roof (20 cm from the center of the roof, along the width of the vehicle, driver side). Refer to Appendix A for antenna location and distance.

MPE measurements for bystander (BS) conditions are determined by taking the average of (10) measurements in a 2m vertical line for each of the (5) bystander test locations indicated in Appendix A with 20 cm height increments at the test distance of 90cm from the test vehicle body.

The measurement probe is positioned orthogonal to antenna (typically parallel to ground with a vertically mounted antenna) and aimed directly at the antenna's axis. These measurements are representative of persons other than the operator standing next to the vehicle.

13.2 Internal/Passenger vehicle MPE measurements

Antenna is located at the side of the roof (20 cm from the center of the roof, along the width of the vehicle, driver side). Refer to Appendix A for antenna location and distance. MPE measurements for passenger front seat (PF) and backseat (PB) conditions are determined by taking the average of the (3) measurements (Head, Chest, and Lower Trunk) inside the vehicle for both the front and back seats.

The backseat is a bench seat and therefore each position (Head, Chest & Lower Trunk) were scanned across (horizontally) the seat starting from the middle of the seat to the edge of the seat stopping 20 cm from the vehicle door. Similar process was used in the front bucket seat.

The probe handle is oriented parallel (horizontal) to the ground and pointed towards the back of the vehicle. The probe handle is not oriented normal to the seat surface. The probe head (incorporating the field sensors) is scanned continuously (using the max-hold function available in the meter) along three test axes which are parallel to the seat angle (intended as the line determined by the intersection of the plane of the seat and the plane of the backrest) and are 20 cm from the seat surface. One test axis is at the Head height, another is at the Chest height, and another is at the Lower Trunk height. The maximum field level value recorded for each test axis is logged. The MPE is determined by averaging these three maximum values regardless of the geometrical location where they were observed. For instance, the locations of the three maxima may lie on different vertical (relative to ground) lines.

This approach leads to results that are representative of the exposure of vehicle occupants since it is based on an average across the body portions closest to the antenna for both trunk and roof mount positions, and is conservatively biased because the highest results for each test axis are combined, e.g. the highest head exposure could be in the middle of the seat while the highest lower trunk exposure could be closer to the door.

14.0 MPE Variability Requirement for External/Bystander vehicle MPE measurement

If all the MPE bystander measurements for a particular antenna are below 50% of the MPE limit, no variability testing for that antenna is required.

If one or more MPE bystander measurements for a particular is between 50-80% of the MPE limit, with no results > 80%, variability testing shall be done on the single worst case for that antenna.

For any MPE bystander measurement above 80% of the MPE limit, variability testing shall be done for all of such configuration. When SAR simulation is performed for a particular antenna configuration to determine compliance, variability measurements are not required for that antenna configuration.

15.0 MPE Calculations

The final MPE results for DVR and Companion Mobile are presented in section 17.0. These results are based on 50% duty cycle for Companion Mobile (PTT operation) and 100% duty cycle for DVR (repeater operation).

Below is an explanation of how the MPE results are calculated. Refer to Appendix I for DVR 700; Appendix J, K, L and M for Companion Mobile LMR bands VHF, UHF1, UHF2 and 7/800.

External to vehicle (Bystander) - 10 measurements are averaged over the body (*Avg_over_body*).
Internal to vehicle (Passengers) - 3 measurements are averaged over the body (*Avg_over_body*).

The Average over Body test methodology is consistent with IEEE/ANSI C95.3-2002 guidelines.

Therefore;

Equation 2 – Power Density Calculation (*Calc._P.D.*)

$$\text{Calc.}_P.D. = (\text{Avg_over_body}) * (\text{probe_frequency_cal_factor}) * (\text{duty_cycle})$$

Note 1: The highest “average” cal factors from the calibration certificates were selected for the applicable frequency range. Linear interpretation was used to determine “probe_frequency_cal_factor” for the specific test frequencies.

Note 2: The E-field probe calibration certificate’s frequency cal factors were determined by measuring V/m. The survey meter’s results were measured in power density (mW/cm^2) and therefore the “probe_frequency_cal_factor” was squared in equation 2 to account for these results.

Note 3: The H-field probe calibration certificate’s frequency cal factors were determined by measuring A/m. The survey meter’s results were measured in A/m and therefore the “Avg_over_body” A/m results were converted to power density (mW/cm^2) using the equation 3. H-field measurements are only applicable to frequencies below 300MHz.

Equation 3 – Converting A/m to mW/cm²

$$mW/cm^2 = (A/m)^2 * 37.699$$

Equation 4 – Power Density Maximum Calculation

$$Max_Calc._P.D. = P.D._calc * \frac{max_output_power}{initial_output_power}$$

Note 4: For initial output power > max_output_power; max_output_power / initial output power = 1

16.0 Antenna Summary

Table below summarizes the tested or evaluated antennas and their descriptions, mount location (roof/trunk), overlap of FCC bands, number of test channels per FCC KDB 447498 (FCC N_c). This information was used to determine the test configurations presented in this report.

Table 8 – Antennas

Antenna No.	Antenna Model	Frequency Range (MHz)	Physical Length (cm)	Gain (dBi)	Remarks	Mount Location (Roof/Trunk)	Overlap FCC Bands (MHz)	FCC N _c
DVR 700								
1	HAF4016A	764-870	9	2.15	1/4 wave	Trunk	769-775; 799-806	4
Companion Mobile								
VHF (136- 174 MHz)								
2	HAD4016A	136-162	51.3	2.15	1/4 wave	Roof	150.8-162	3
3	HAD4017A	146-174	46.2	2.15	1/4 wave	Roof	150.8-173.4	4
4	HAD4021A	136-174	51.7	2.15	1/4 wave	Roof	150.8-173.4	4
5	HAD4006A	136-144	52.0	2.15	1/4 wave	Roof	NA	NA
6	HAD4007A	144-150.8	49.0	2.15	1/4 wave	Roof	150.8	1
7	HAD4008A	150.8-162	45.5	2.15	1/4 wave	Roof	150.8-162	3
8	HAD4009A	162-174	43.0	2.15	1/4 wave	Roof	162-174	3
9	*HAD4022A	132-174	130.0 (136 MHz) 118.5 (144 MHz) 114 (150.8 MHz) 102.7 (158.0125 MHz) 96.5 (165.0125 MHz) 89.9 (173.0125 MHz)	5.15	5/8 wave	Roof	150.8-173.4	4
10	*RAD4010ARB	136-174	143.5 (136 MHz) 130.5 (146 MHz) 126.8 (150.8 MHz) 116.5 (158.0125 MHz) 112.5 (165.0125 MHz) 103.7 (173.0125 MHz)	5.15	1/2 wave	Roof	150.8-173.4	4
UHF1 (380-470 MHz)								
11	HAE6010A	380-433	63.5	5.65	1/2 wave	Roof	406.1-433	3
12	HAE6011A	380-433	91.0	7.15	5/8 wave	Roof	406.1-433	3
13	HAE6012A	380-433	18.2	2.15	1/4 wave	Roof	406.1-433	3
14	HAE6013A ⁽¹⁾	380-470	29	4.15	1/2 wave	Roof	406.1 -470	6
15	HAE6031A ⁽¹⁾	380-520	28	4.15	1/2 wave	Roof	406.1-470	5
16	HAE4003A ⁽¹⁾	450-470	16	2.15	1/4 wave	Roof	450-470	3
17	HAE4011A ⁽¹⁾	450-470	73.2	5.65	1/2 wave	Roof	450-470	3
18	HAE6015A ⁽¹⁾	450-520	26.2	4.15	1/2 wave	Roof	450-470	3
19	HAE6016A ⁽¹⁾	450-512	8.3	2.15	1/4 wave	Roof	450-470	3
20	*RAE4014ARB ⁽¹⁾	445-470	92.7 (450.0125 MHz) 90.5 (460 MHz) 89.0 (469.9875 MHz)	7.15	5/8 wave	Roof	450-470	3

Notes:

(1): Antennas support UHF1 & UHF2 frequency range.

* Antenna length trimmed to frequency.

Table 8 (Continued) – Antennas

Antenna No.	Antenna Model	Frequency Range (MHz)	Physical Length (cm)	Gain (dBi)	Remarks	Mount Location (Roof/ Trunk)	Overlap FCC Bands (MHz)	FCC N _c
UHF2 (450-520 MHz)								
14	HAE6013A ⁽¹⁾	380-470	29	4.15	1/2 wave	Roof	450-470	3
15	HAE6031A ⁽¹⁾	380-520	28	4.15	1/2 wave	Roof	450-512	5
16	HAE4003A ⁽¹⁾	450-470	16	2.15	1/4 wave	Roof	450-470	3
17	HAE4011A ⁽¹⁾	450-470	73.2	5.65	1/2 wave	Roof	450-470	3
18	HAE6015A ⁽¹⁾	450-520	26.2	4.15	1/2 wave	Roof	450-512	5
19	HAE6016A ⁽¹⁾	450-512	8.3	2.15	1/4 wave	Roof	450-512	5
20	*RAE4014ARB ⁽¹⁾	445-470	92.7 (450.0125 MHz) 90.5 (460 MHz) 89.0 (469.9875 MHz)	7.15	5/8 wave	Roof	450-470	3
21	HAE4004A	470-512	15	2.15	1/4 wave	Roof	470-512	4
22	HAE4012A	470-495	68.5	5.65	1/2 wave	Roof	470-495	3
23	HAE4013A	494-512	64.3	5.65	1/2 wave	Roof	494-512	3
24	*RAE4015ARM	470-494	89.0 (470.0125 MHz) 86.4 (482.5 MHz) 85.0 (493.9875 MHz)	7.15	5/8 wave	Roof	470-494	3
25	*RAE40416ARB	494-512	85.7 (494.9875 MHz) 83.6 (503 MHz) 83.3 (511.9875 MHz)	7.15	5/8 wave	Roof	494-512	3
7/800 (764-870 MHz)								
26	HAF4013A	764-870	6.1	5.15	1/4 wave	Roof	769-775; 799-824; 851-869	8
27	HAF4014A	764-870	57.7	5.15	1/4 wave	Roof	769-775; 799-824; 851-869	8
28	HAF4016A	764-870	9	2.15	1/4 wave	Roof	769-775; 799-824; 851-869	8
29	HAF4017A	764-870	34.5	5.15	1/4 wave	Roof	769-775; 799-824; 851-869	8
All bands (136-870 MHz)								
30	AN000131A01	136-870	55.7	2.15	Roof	150.8-173.4 (VHF)	4	6
					Roof	406.1- 470 (UHF1)	5	7
					Roof	450-512 (UHF2)	5	6
					Roof	769-775; 799-824; 851-869 (7/800)	8	9
WLAN								
31	PMAN5100A	2400-2500	5.7 (L) x 1.9 (W)	6		Glass mount	2412-2462	3
32	AN000163A01	2400-2500 / 4900-5900	7	5.15	Monopole	Trunk	2412-2462 ; 5180-5825	3
33	AN000163A05	2400-2500 / 4900-5900	7	5.15	Monopole	Roof/ Trunk	2412-2462 ; 5180-5825	3
34	PMAN5101A	2400-2500 / 4900-5900	5.4 (L) x 1.32 (W)	6 / 3.2		Glass mount	2412-2462 ; 5180-5825	3

Notes:

(1): Antennas support UHF1 & UHF2 frequency range.

* Antenna length trimmed to frequency.

17.0 Test Results Summary

17.1 MPE Test Results Summary for DVR and Companion Mobile (LMR)

Refer to the following appendices for MPE test results for each test configuration: antenna location, test positions (BS1-Bystander test location #1, BS2-Bystander test location #2, BS3-Bystander test location #3, BS4-Bystander test location #4, BS5-Bystander test location #5, PB-Passenger Backseat, PF-Passenger Front seat), E/H field measurements, antenna model & freq. range, maximum output power, initial power, TX frequency, max calculated power density results, applicable FCC specification limits and % of the applicable specification limits.

- Appendix D for DVR 700
- Appendix E, F, G and H for Companion Mobile

Table 9 summarized the highest maximum calculated power density and highest % of the applicable specification limit for each standalone transmitters (DVR, Companion Mobile).

Table 9

Test Positions	DVRS 700 (FCC ID: LO6-DVRSUHF)		Companion Mobile APX8500 HP (FCC ID: AZ492FT7118)							
	764-776 MHz; 794-806 MHz		VHF (136-174 MHz)		UHF1 (380-470 MHz)		UHF2 (450-520 MHz)		7/800 (764-870 MHz)	
	Power Density (mw/cm ²)	Highest % of Limit	Power Density (mw/cm ²)	Highest % of Limit	Power Density (mw/cm ²)	Highest % of Limit	Power Density (mw/cm ²)	Highest % of Limit	Power Density (mw/cm ²)	Highest % of Limit
FCC US										
Passenger, Front Seat (PF)	0.031	6.1%	0.176	88.0%	0.064	22.7%	0.068	22.6%	0.027	5.0%
Passenger, Back Seat (PB)	0.038	7.3%	0.424	212.1%	0.123	45.4%	0.111	37.1%	0.043	8.4%
Bystander #1 (BS-1)	0.004	0.8%	0.172	86.2%	0.107	39.3%	0.104	34.6%	0.032	5.9%
Bystander #2 (BS-2)	0.011	2.1%	0.157	78.3%	0.078	26.8%	0.069	23.1%	0.026	4.7%
Bystander #3 (BS-3)	0.018	3.6%	0.126	62.9%	0.058	18.9%	0.058	18.9%	0.013	2.4%
Bystander #4 (BS-4)	0.017	3.3%	0.097	48.3%	0.045	16.0%	0.036	11.5%	0.014	2.6%
Bystander #5 (BS-5)	0.020	3.9%	0.076	38.0%	0.031	10.3%	0.031	10.3%	0.013	2.4%

17.2 MPE Test Results for Companion Mobile (WLAN)

Antenna PMAN5100A supports WLAN 2.4 GHz only and PMAN5101A supports WLAN 2.4 GHz / 5 GHz, both antennas intended for mounting on the windshield of the vehicle. These antennas should be installed close to the top, and on the front windshield only. Antennas AN000163A01 and AN000163A05 support WLAN 2.4 GHz / 5 GHz should be installed at roof or trunk of the vehicle. WLAN 2.4 GHz and 5 GHz will not transmit simultaneously.

MPE calculation was use to determine power density for these transmitters due to lower power. According to FCC’s OET Bulletin 65 Edition 97-01 Section 2, calculations can be made to predict RF field strength and power density levels around typical RF sources. Equation (5) is generally accurate in far-field of an antenna.

Equation 5 – Power Density Calculation

$$S = \frac{P_t G}{4\pi d^2} F$$

Equation (5) accounts for the maximum duty cycle of the signal, and the factor, F, to provide a worst-case prediction of power density per FCC OET Bulletin 65, Edition 97-01 1997.

- Where:
- S = power density
 - P_t = maximum output power scaled by the maximum duty cycle of the signal
 - G = power gain of the antenna in the direction of interest relative to an isotropic radiator
 - d = distance from antenna
 - F = Enhancement factor [1 or 2.56 for predicting ground-level field strength]

Table 10 summarized the MPE calculation for WLAN.

Table 10

Antenna #	Max Power (W)	Duty Cycle (%)	Tx Frequency (MHz)	Antenna Gain (dBi)	Cable Loss, L (dB)	Dist., d (cm)	Enhance Factor, F	Max Calc. MPE (mW/cm ²)	FCC Limit (mW/cm ²)	% To FCC Spec Limit
WLAN 2.4 GHz										
PMAN5100A	0.0631	100.00%	2412.0	6.00	2.20	20	1.00	0.0301	1.00	3.01
PMAN5100A	0.0631	100.00%	2437.0	6.00	2.20	20	1.00	0.0301	1.00	3.01
PMAN5100A	0.0631	100.00%	2462.0	6.00	2.20	20	1.00	0.0301	1.00	3.01
PMAN5101A	0.0631	100.00%	2412.0	6.00	3.00	20	1.00	0.0250	1.00	2.50
PMAN5101A	0.0631	100.00%	2437.0	6.00	3.00	20	1.00	0.0250	1.00	2.50
PMAN5101A	0.0631	100.00%	2462.0	6.00	3.00	20	1.00	0.0250	1.00	2.50
AN000163A01 / AN000163A05	0.0631	100.00%	2412.0	5.15	2.20	20	1.00	0.0248	1.00	2.48
AN000163A01 / AN000163A05	0.0631	100.00%	2437.0	5.15	2.20	20	1.00	0.0248	1.00	2.48
AN000163A01 / AN000163A05	0.0631	100.00%	2462.0	5.15	2.20	20	1.00	0.0248	1.00	2.48
WLAN 5 GHz										
AN000163A01 / AN000163A05	0.0316	100.00%	5180.0	5.15	3.47	20	1.00	0.009	1.00	0.93
AN000163A01 / AN000163A05	0.0316	100.00%	5502.5	5.15	3.47	20	1.00	0.009	1.00	0.93
AN000163A01 / AN000163A05	0.0316	100.00%	5825.0	5.15	3.47	20	1.00	0.009	1.00	0.93
PMAN5101A	0.0316	100.00%	5180.0	3.20	4.00	20	1.00	0.0052	1.00	0.52
PMAN5101A	0.0316	100.00%	5502.5	3.20	4.00	20	1.00	0.0052	1.00	0.52
PMAN5101A	0.0316	100.00%	5825.0	3.20	4.00	20	1.00	0.0052	1.00	0.52

Notes:

- 1) Distance from antenna (d), 20cm for more conservative estimation.
- 2) Cable loss (L),
 - 2.20 dB with 17' PFP240 cable for 2.4 GHz WLAN (Antenna PMAN5100A, AN000163A0, AN000163A05)
 - 3.00 dB with 1' RG316 and 16' PFP195 cable for 2.4 GHz WLAN (Antenna PMAN5101A)
 - 3.47 dB with 17' PFP240 cable for 5.0 GHz WLAN (Antenna AN000163A0, AN000163A05)
 - 4.00 dB with 1' RG316 and 16' PFP195 cable for 5.0 GHz WLAN (Antenna PMAN5101A)
- 3) Numeric gain (G), factor in the cable loss with conversion $10^{((dBi-L)/10)}$
- 4) Enhancement Factor (F), 1 (Ground reflection already factor in during antenna characterization)

17.3 Simultaneous Transmission

DVR will transmit simultaneously with Companion mobile; refer to Table 7 for all simultaneous transmission conditions.

LMR bands can transmit simultaneously with WLAN 2.4 GHz or WLAN 5 GHz. WLAN 2.4 GHz and WLAN 5 GHz cannot transmit at the same time.

The combine MPE results for DVR and Companion Mobile were calculated base on the percent of MPE limit for each applicable test channels according to the formula below. This is due to the signals emitted by each individual transmitter are statistically uncorrelated; the collective compliance of the transmitters is determined by summing the individual ratios between actual measured power density (S) and maximum allowed MPE exposure. Compliance is achieved if the total exposure (T) is less than one.

Formula:

$$T = \frac{S_1}{MPE_1} + \frac{S_2}{MPE_2} + \dots < 1$$

The highest combined power density percentage of the applicable specification limits are indicating in table 11.

Table 11- Highest Combine MPE % of limits

Test Positions	DVRS 700	Companion Mobile APX8500 HP					Simultaneous Transmission							
	764-776 MHz; 794-806 MHz	WLAN	VHF (136-174 MHz)	UHF1 (380-470 MHz)	UHF2 (450-520 MHz)	7/800 (764-870 MHz)	DVRS + WLAN+LMR_VHF		DVRS + WLAN+LMR_UHF1		DVRS + WLAN+LMR_UHF2		DVRS + WLAN+LMR_7800	
	[1] Highest % of Limit	[2] Highest % of Limit	[3] Highest % of Limit	[4] Highest % of Limit	[5] Highest % of Limit	[6] Highest % of Limit	[1]+[2]+[3] Combine % of Limit	Table No.	[1]+[2]+[4] Combine % of Limit	Table No.	[1]+[2]+[5] Combine % of Limit	Table No.	[1]+[2]+[6] Combine % of Limit	Table No.
	FCC US													
Passenger, Front Seat (PF)	6.1%	3.01%	88.0%	22.7%	22.6%	5.0%	97.1%		31.8%		31.7%		14.1%	
Passenger, Back Seat (PB)	7.3%	3.01%	212.1%	45.4%	37.1%	8.4%	222.4%	Table 12	55.7%		47.4%		18.7%	
Bystander #1 (BS-1)	0.8%	3.01%	86.2%	39.3%	34.6%	5.9%	90.0%		43.1%		38.4%		9.7%	
Bystander #2 (BS-2)	2.1%	3.01%	78.3%	26.8%	23.1%	4.7%	83.4%		31.9%		28.2%		9.8%	
Bystander #3 (BS-3)	3.6%	3.01%	62.9%	18.9%	18.9%	2.4%	69.5%		25.5%		25.5%		9.0%	
Bystander #4 (BS-4)	3.3%	3.01%	48.3%	16.0%	11.5%	2.6%	54.6%		22.3%		17.8%		8.9%	
Bystander #5 (BS-5)	3.9%	3.01%	38.0%	10.3%	10.3%	2.4%	44.9%		17.2%		17.2%		9.3%	

Note: Refer to indicated table no. for result in bold to determine configurations that require SAR simulations.

Table 12 – Combined MPE % of FCC US limit (Passenger, Back Seat)

					[1] DVRS 700 Antenna (Trunk Mounted)					
					E/H Field		E Field			
					DVRS Antenna		HAF4016A, 1/4 Wave (764-870MHz)			
					DVR Freq (MHz)		770.0000	775.0000	800.0000	806.0000
	E/H Field	Companion Mobile Antenna	LMR Freq (MHz)	% of FCC Limit	6.8	7.3	4.1	3.8		
	[2]+[3] Companion Mobile (roof Mounted)		E Field	AN000131A01, 1/4 wave (136-870MHz)	150.8000	145.7	*152.51	*153.01	*149.81	*149.51
158.0125		188.7			*195.51	*196.01	*192.81	*192.51		
165.0125		178.2			*185.01	*185.51	*182.31	*182.01		
173.0125		65.8			72.6	73.1	69.9	69.6		
HAD4021A, 1/4 Wave (136-174MHz)		150.8000		161.1	*167.91	*168.41	*165.21	*164.91		
		158.0125		167.9	*174.71	*175.21	*172.01	*171.71		
		165.0125		141.7	*148.51	*149.01	*145.81	*145.51		
		173.0125		52.5	59.3	59.8	56.6	56.3		
HAD4017A, 1/4 Wave (146-174MHz)		150.8000		110.9	*117.71	*118.21	*115.01	*114.71		
		158.0125		182.0	*188.81	*189.31	*186.11	*185.81		
		165.0125		186.1	#192.91	#193.41	#190.21	#189.91		
		173.0125		76.1	82.9	83.4	80.2	79.9		
HAD4016A, 1/4 Wave (136-162MHz)		150.8000		153.8	*160.61	*161.11	*157.91	*157.61		
		156.4000		163.8	*170.61	*171.11	*167.91	*167.61		
		162.0000		174.0	*180.81	*181.31	*178.11	*177.81		
HAD4007A, 1/4 Wave (144-150.8MHz)		150.8000		187.9	*194.71	*195.21	*192.01	*191.71		
HAD4008A, 1/4 Wave (150.8-162MHz)		150.8000		128.1	*134.91	*135.41	*132.21	*131.91		
		156.4000		177.8	*184.61	*185.11	*181.91	*181.61		
		162.0000		173.5	#180.31	#180.81	#177.61	#177.31		
HAD4009A, 1/4 Wave (162-174MHz)		162.0000		145.2	#152.01	#152.51	#149.31	#149.01		
		165.0125		176.1	*182.91	*183.41	*180.21	*179.91		
		173.0125		50.6	57.4	57.9	54.7	54.4		
HAD4022A, 5/8 Wave (132-174MHz)		150.8000		58.8	65.6	66.1	62.9	62.6		
		158.0125		77.0	83.8	84.3	81.1	80.8		
		165.0125		85.3	92.1	92.6	89.4	89.1		
		173.0125		47.0	53.8	54.3	51.1	50.8		
RAD4010ARB, 1/2 Wave (136-174MHz)		150.8000		32.8	39.6	40.1	36.9	36.6		
		158.0125		48.6	55.4	55.9	52.7	52.4		
		165.0125		34.2	41.0	41.5	38.3	38.0		
		173.0125		37.1	43.9	44.4	41.2	40.9		

Notes:
 * Configurations require SAR simulations.
 # Same SAR simulation configurations as H Field.

Table 12 Continued– Combined MPE % of FCC US limit (Passenger, Back Seat)

					[1] DVRS 700 Antenna (Trunk Mounted)					
					E/H Field		E Field			
					DVRS Antenna		HAF4016A, 1/4 Wave (764-870MHz)			
					DVR Freq (MHz)		770.0000	775.0000	800.0000	806.0000
	E/H Field	Companion Mobile Antenna	LMR Freq (MHz)	% of FCC Limit	6.8	7.3	4.1	3.8		
									#132.71	#133.21
[2]+[3] Companion Mobile (roof Mounted)	H Field	AN000131A01, 1/4 wave (136-870MHz)	150.8000	125.9	#132.71	#133.21	#130.01	#129.71		
			158.0125	154.5	#161.31	#161.81	#158.61	#158.31		
			165.0125	135.2	#142.01	#142.51	#139.31	#139.01		
			173.0125	43.7	50.5	51.0	47.8	47.5		
		HAD4021A, 1/4 Wave (136-174MHz)	150.8000	129.4	#136.21	#136.71	#133.51	#133.21		
			158.0125	136.0	#142.81	#143.31	#140.11	#139.81		
			165.0125	126.5	#133.31	#133.81	#130.61	#130.31		
			173.0125	49.8	56.6	57.1	53.9	53.6		
		HAD4017A, 1/4 Wave (146-174MHz)	150.8000	93.8	#100.61	#101.11	97.9	97.6		
			158.0125	155.4	#162.21	#162.71	#159.51	#159.21		
			165.0125	215.1	*221.91	*222.41	*219.21	*218.91		
			173.0125	74.2	81.0	81.5	78.3	78.0		
		HAD4016A, 1/4 Wave (136-162MHz)	150.8000	137.8	#144.61	#145.11	#141.91	#141.61		
			156.4000	147.1	#153.91	#154.41	#151.21	#150.91		
			162.0000	163.0	#169.81	#170.31	#167.11	#166.81		
		HAD4007A, 1/4 Wave (144-150.8MHz)	150.8000	136.5	#143.31	#143.81	#140.61	#140.31		
		HAD4008A, 1/4 Wave (150.8-162MHz)	150.8000	108.8	#115.61	#116.11	#112.91	#112.61		
			156.4000	160.5	#167.31	#167.81	#164.61	#164.31		
			162.0000	185.0	*191.81	*192.31	*189.11	*188.81		
		HAD4009A, 1/4 Wave (162-174MHz)	162.0000	146.8	*153.61	*154.11	*150.91	*150.61		
			165.0125	142.4	#149.21	#149.71	#146.51	#146.21		
			173.0125	59.2	66.0	66.5	63.3	63.0		
		HAD4022A, 5/8 Wave (132-174MHz)	150.8000	46.5	53.3	53.8	50.6	50.3		
			158.0125	76.5	83.3	83.8	80.6	80.3		
			165.0125	88.0	94.8	95.3	92.1	91.8		
			173.0125	47.1	53.9	54.4	51.2	50.9		
		RAD4010ARB, 1/2 Wave (136-174MHz)	150.8000	29.9	36.7	37.2	34.0	33.7		
158.0125	43.1		49.9	50.4	47.2	46.9				
165.0125	21.7		28.5	29.0	25.8	25.5				
173.0125	23.3		30.1	30.6	27.4	27.1				

Notes:
 * Configurations require SAR simulations.
 # Same SAR simulation configurations as E Field.

18.0 Conclusion

The assessment for DVR and Companion mobile were performed as indicate in section 17.1 with an output power range listed in Table 6 and WLAN MPE calculation in section 17.2. The maximum allowable output power is equal to the upper limit of the final test factory transmit power specification listed in Table 6. The highest power density results for DVR and Companion Mobile scaled to maximum allowable power output are indicated in Table 13 (FCC US) for internal/passenger of to the vehicle, and external/bystander to the vehicle.

These MPE results herein demonstrate compliance to FCC Occupation/Controlled Exposure limit. However, FCC rules required compliance for Passengers and Bystanders to FCC General Population / Uncontrolled limits. Maximum Combined MPE percentage in bold exceed General Population / Uncontrolled limit.

Table 13 – Maximum MPE RF Exposure Summary (FCC US)

DVRS 700 (FCC ID: LO6-DVRS700) Trunk Mounted Antenna					
Equipment Class	Frequency Band (MHz)	Passenger		Bystander	
		Power Density (mw/cm ²)	Highest % of Limit	Power Density (mw/cm ²)	Highest % of Limit
TNB	769-775 MHz; 799-806 MHz	0.038	7.3%	0.020	3.9%
Companion Mobile APX8500 (FCC ID: AZ492FT7118) Roof Mounted Antenna					
Equipment Class	Frequency Band (MHz)	Passenger		Bystander	
		Power Density (mw/cm ²)	Highest % of Limit	Power Density (mw/cm ²)	Highest % of Limit
TNB	VHF (150.8 – 173.4 MHz)	0.424	212.1%	0.172	86.2%
	UHF1 (406.1-470 MHz)	0.123	45.4%	0.107	39.3%
	UHF2 (450-512 MHz)	0.111	37.1%	0.104	34.6%
	7/800 (769-775 MHz; 799-824 MHz;851-869 MHz)	0.043	8.4%	0.032	5.9%
DTS	WLAN (2412-2462 MHz)	0.030	3.01%	0.030	3.01%
NII	WLAN (5180 - 5825 MHz)	0.009	0.93%	0.009	0.93%
Simultaneous Transmissions					
Simultaneous Transmissions conditions		Passenger		Bystander	
		Highest Combine % of limit		Highest Combine % of limit	
DVRS 700 + WLAN + VHF		222.4%		90.0%	
DVRS 700 + WLAN + UHF1		55.7%		43.1%	
DVRS 700 + WLAN + UHF2		47.4%		38.4%	
DVRS 700 + WLAN + 7/800		18.7%		9.8%	

Note: Result in bold required SAR simulation.

Although MPE is a convenient method of demonstrating RF Exposure requirements, SAR is recognized as the “basic restriction”. For those configurations indicate with “*” in Table 12, compliance to the General Population / Uncontrolled SAR 1g limit of 1.6 W/kg is demonstrated through SAR computational analysis.

The computational results show that this DVR 700 device, when used with Companion Mobile radio APX8500 HP and specified antennas, exhibit a maximum combine SAR are indicated in the Table 14.

Table 14

	Exposure Conditions	Combined SAR (W/kg)	
		1-g	WB
FCC	Passenger Back	0.64	0.023

19.0 User Instructions Considerations

In order to facilitate the requirements for occupational exposure limits, the Safety Manual for this radio requires the radio operator to maintain 90 cm in all directions between the vehicle and external persons while transmitting.

Appendix A - Antenna Locations, Test Distances, and Cable Losses

Antenna locations

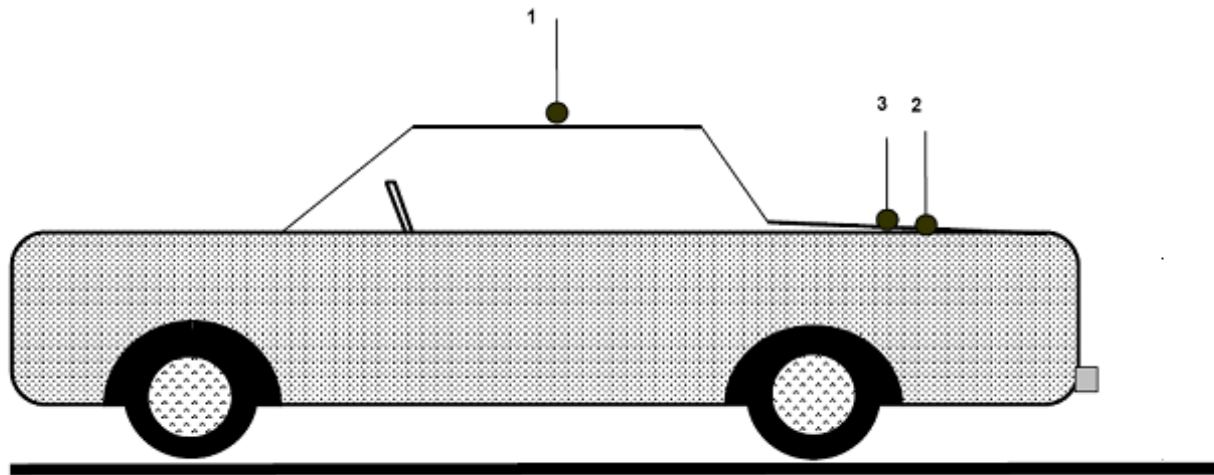

1. Roof (20cm from center)
2. Trunk (85cm from back of the back seat)
3. Trunk (center)

Passenger Antenna mounting

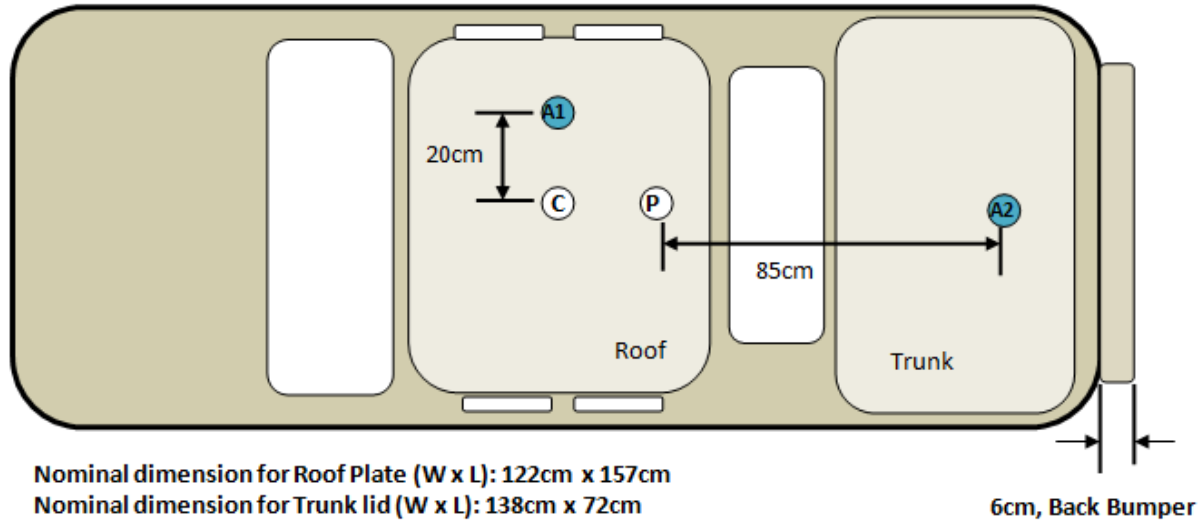

Note:

- 1.) Antenna location A1: APX mobile radio roof antenna mounting locations for passenger and bystander testing
- 2.) Antenna location A2: DVR trunk antenna mounting locations for passenger back testing
- 3.) Total distance between trunk mount antenna and rear passenger is 85cm

Bystander Antenna mounting and test locations

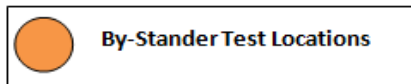
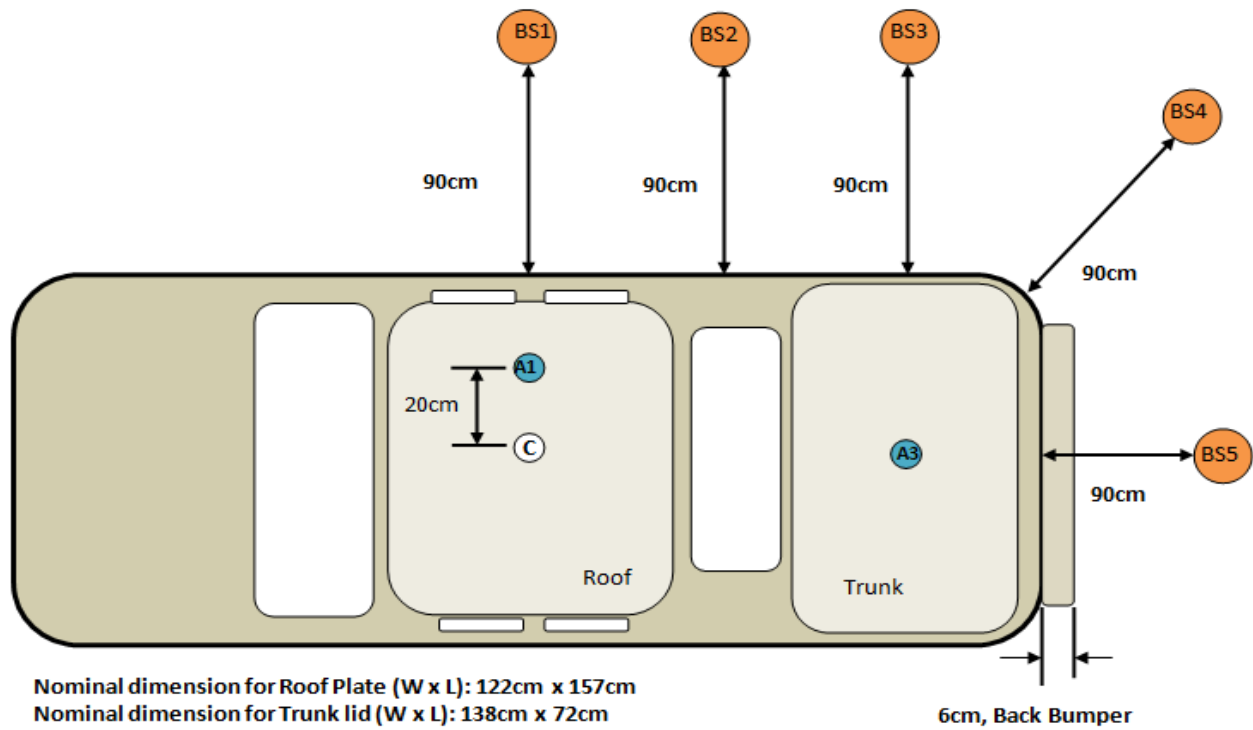

Note:

- 1.) Antenna location A1: APX mobile radio roof antenna mounting locations for passenger and bystander testing
- 2.) Antenna location A3: DVR trunk antenna mounting locations for bystander testing
- 3.) Bystander location BS2: Center point of the bystander test location BS1 and test location BS3
- 4.) Bystander location BS (1-5): 90cm away from the vehicle body. Apply for both roof and trunk testing

Seat scan areas (Applicable to both front and back seats)

Meter - Probe

 Probe diameter is 5.5cm

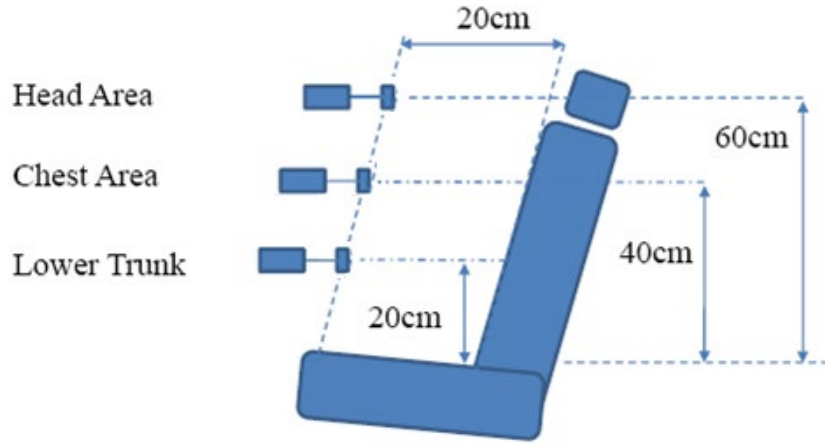

MPE Test Configuration

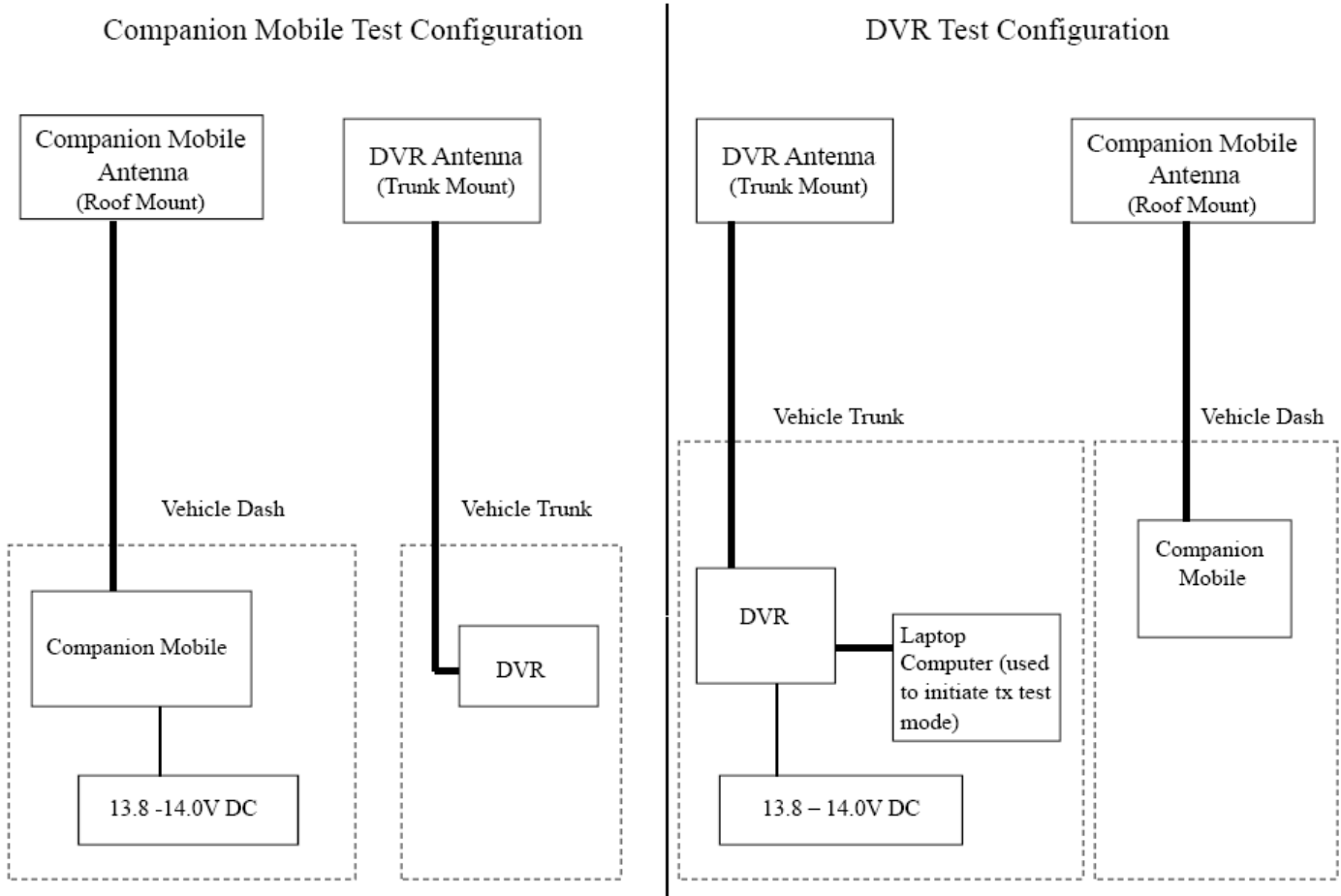

Cable Losses

Test Cable

Teflon RG58A/U Loss Per 100 Feet

160 MHz - 5 dB

450 MHz - 9 dB

1 GHz - 13.8 dB

Customer Cable

RG-58A/U Loss Per 100 Feet

136 MHz – 5.5 dB

450 MHz – 9.6 dB

900 MHz – 13.9 dB

PFP 240 Loss Per 100 Feet (For BT/WLAN)

2500 MHz - 12.9 dB

5800 MHz – 20.4 dB

Appendix B - Probe Calibration Certificates

Service Test Report
QAF 1126, 03/11
Report ID: 125391



Certificate of Test Conformance Page 1 of 1

Reference: S 000043311

Customer: Motorola Solutions Malaysia Sdn. Bhd. - 2A, Medan Bayan Lepas, Baymen Lepas Technoplex, 11900 Bayan Lepas, Pulau Pinang, Malaysia

The instrument listed below has been tested and verified to Internal Quality Standards. Test data is Attached. Equipment used during instrument testing is controlled by laboratory compliance with ISO/IEC 17025-2005 and ANSI/NCSL Z540-1-1994 using ETS-Lindgren Quality Management System internal procedures.

<u>Manufacturer</u>	ETS-Lindgren	<u>Status In</u>	In Tolerance
<u>Instrument Type</u>	RF Survey Meter	<u>Date Completed</u>	02-Jul-18
<u>Model</u>	HI-2200	<u>Status Out</u>	Compliant with Internal Quality Standards
<u>Serial Number/ID</u>	00086316		

Remarks
Tested with customer E100 00206767 and customer H200 00206937.

I would like to take this opportunity to express our appreciation for using ETS-Lindgren for your EMI test equipment services and I am looking forward to continued business with your organization. Please feel free to contact our offices at (512) 531-6400, if you have any questions regarding this report.

Sincerely,

George Cisneros
Calibration Supervisor

Date Attested: 02-Jul-18



Cert I.D.: 125390

Certificate of Calibration Conformance
Page 1 of 3

The instrument identified below has been individually calibrated in compliance with the following standard(s):

IEEE 1309 - 2013, Institute of Electrical and Electronics Engineers, Standard for Calibration of Electromagnetic Field Sensors and Probes, Excluding Antennas from 9 kHz to 40 GHz

Environment: Laboratory MTE is maintained in a temperature controlled environment with ambient conditions from 18 to 28 C, relative humidity less than 90%. The instrument under test has been calibrated in a suitable environment using an EMCO TEM Cell 5101C, GTEM 5305/5402 and an RF Shielded EMC Chamber which is conducive to maintaining accurate and reliable measurement quality.

Manufacturer:	ETS-Lindgren	Operating Range:	100kHz - 5GHz
Model Number:	E100	Instrument Type:	Isotropic Probe > 1 GHz
Serial Number/ ID:	00206767	Date Code:	
Tracking Number:	S 000043311	Alternate ID:	
Date Completed:	02-Jul-18	Customer:	Motorola Solutions Malaysia Sdn. Bhd. - 2A, Medan Bayan Lepas, Baymen Lepas Technoplex, 11900 Bayan Lepas, Pulau Pinang, Malaysia
Test Type:	Standard Field, Field Strength		

Calibration Uncertainty: Std Field Method 100kHz - 6 GHz, +/-0.64 dB, Linearity +/- 0.95 dB, Isotropy +/- 0.86
k=2, (95% Confidence Level)

Test Remarks: Probe received in tolerance thus before and after data are the same. Additional data points included as per customer request. Tested with customer HI-2200 00066316.

Calibration Traceability: All Measuring and Test Equipment (MTE) identified below are traceable to the SI units through the National Institute for Standards and Technology (NIST) or other recognized National Metrology Institute. Calibration Laboratory and Quality System controls are compliant with ISO/IEC 17025-2005 and ANSI/NCSL Z540-1-1994.

Standards and Equipment Used:

Make / Model / Name / S/N / Recall Date				
HP 8848C	Signal Generator	3836U02236	16-Mar-19	
Keysight E9304A	Power Sensor	MY56100039	16-Mar-19	
Hewlett Packard E4422B	Signal Generator	US40050591	09-Aug-18	
Agilent E4419B	Power Meter	MY45104171	27-Jan-19	
Rohde & Schwarz SMB 100A	Signal Generator	101558	13-Sep-18	
Agilent E9304A	Power Sensor	MY41499013	16-Mar-19	
Agilent E9304A	Power Sensor	MY41499012	16-Mar-19	
Rohde & Schwarz NRP-Z91	Power Sensor	100733	28-Jan-19	
Agilent E4419B	Power Meter	MY40510693	27-Jan-19	
Rohde & Schwarz NRP-Z21	Power Sensor	100525	06-Sep-18	
Rohde & Schwarz NRV-Z55	Thermal Power Sensor	100354	14-Nov-18	
Rohde & Schwarz NRP-Z11	Power Sensor	108043	24-Jan-19	
Marconi 2024	Signal Generator	112343/043	06-Apr-19	
Rohde & Schwarz NRVD	Power Meter	100451	06-Sep-18	
Hewlett Packard 83650L	Synthesized Sweep Gen	3844A00422	20-Dec-18	
Hewlett Packard E4419B	Power Meter	US39250717	10-Aug-18	
Keysight E9304A	Power Sensor	MY56100005	16-Mar-19	
Rohde & Schwarz NRV-Z55	Thermal Power Sensor	100037	06-Sep-18	
Rohde & Schwarz NRV-Z55	Thermal Power Sensor	100363	14-Nov-18	

Condition of Instrument

Upon Receipt:
In Tolerance to Internal Quality Standards

On Release:
In Tolerance to Internal Quality Standards

Shawn Schmitt
Calibration Completed By
Shawn Schmitt, Calibration Technician

George Cisneros
Attested and Issued on 02-Jul-18
George Cisneros, Calibration Supervisor

This document provides traceability of measurements to recognized national standards using controlled processes at the ETS-Lindgren Calibration Laboratory. Uncertainties listed are derived from the methods described by NIST Tech Note 1297. This certificate and report may not be reproduced, except in full, without the written approval of ETS-Lindgren Calibration Laboratory in accordance with ISO/IEC 17025-2005 and ANSI/NCSL Z540-1-1994. The results in this document relate only to the item(s) listed and should not be considered representative of a population unless otherwise noted. QAF 1127 (03/11)

CALIBRATION REPORT

Electric Field Sensor

<i>Model</i>	<i>S/N</i>
E100	00206767
HI-2200	00086316

Date: 02 Jul 2018

- New Instrument
- Other
- Out of Tolerance
- Within Tolerance

Frequency Response

<i>Frequency Response</i>	<i>MHz</i>	<i>Nominal Field</i>	<i>Cal Factor*</i>	<i>Deviation</i>
		<i>V/m</i>	<i>(Applied/Indicated)</i>	<i>dB</i>
1	1	20	1.05	-0.42
2	15	20	0.98	0.15
3	30	20	0.99	0.13
4	75	20	0.99	0.10
5	100	20	0.99	0.05
6	150	20	0.99	0.07
7	200	20	0.98	0.15
8	250	20	0.98	0.15
9	300	20	0.97	0.25
10	400	20	1.04	-0.33
11	500	20	0.93	0.65
12	600	20	0.93	0.67
13	700	20	0.98	0.21
14	800	20	1.00	0.03
15	900	20	1.03	-0.22
16	1000	20	1.01	-0.10
17	2000	20	1.05	-0.41
18	2450	20	1.04	-0.37
19	3000	20	1.07	-0.61
20	3500	20	1.02	-0.20
21	4000	20	1.03	-0.23
22	4500	20	1.10	-0.81
23	5000	20	1.34	-2.57
24	5500	20	1.49	-3.45
25	6000	20	1.49	-3.48

* Corrected electric field values (V/m) can be obtained by multiplying the Cal Factor with the indicated E field readings.

Linearity

maximum linearity deviation is 0.58 dB
 (measurements taken from 0.3 V/m to 800 V/m at 27.12 MHz)

Test Conditions

Calibration performed at ambient room temperature: 23 ±3°C



PROBE ROTATIONAL RESPONSE

Model E100
S/N 00206767
Report S000043311
Date Date of Calibration 02 July 2018
Time 03:24:41 PM
Isotropy * + 0.177 dB/ -0.177 dB

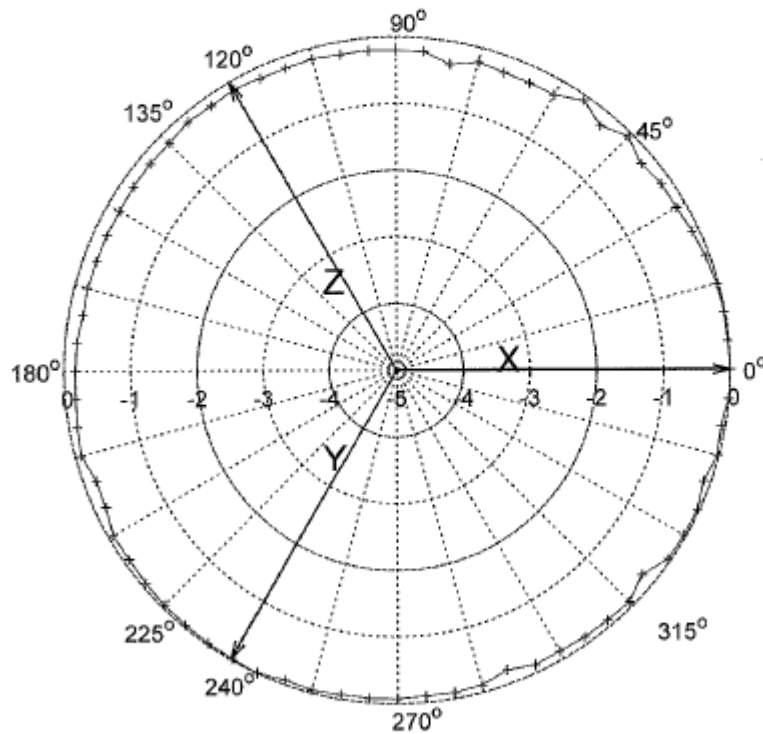

Figure 1: Probe Isotropic Response Chart.

Isotropic response is measured in a 20 V/m field at 400 MHz

*Isotropy is the maximum deviation from the geometric mean as defined by IEEE 1309-2013.



An ESCO Technologies Company
 1301 Arrow Point Drive
 Cedar Park, Texas 78613
 (512) 531-6400



Cert I.D.: 125467

Certificate of Calibration Conformance

Page 1 of 2

The instrument identified below has been individually calibrated in compliance with the following standard(s):

IEEE 1309 - 2013, Institute of Electrical and Electronics Engineers, Standard for Calibration of Electromagnetic Field Sensors and Probes, Excluding Antennas from 9 kHz to 40 GHz

Environment: Laboratory MTE is maintained in a temperature controlled environment with ambient conditions from 18 to 28 C, relative humidity less than 90%. The instrument under test has been calibrated in a suitable environment using an EMCO TEM Cell 5101C, GTEM 5305/5402 and an RF Shielded EMC Chamber which is conducive to maintaining accurate and reliable measurement quality.

Manufacturer:	ETS-Lindgren	Operating Range:	5-300MHz / 30mA/m-10A/m
Model Number:	H200	Instrument Type:	Isotropic Magnetic Field Probe (2)
Serial Number/ ID:	00205937	Date Code:	
Tracking Number:	S 000043311	Alternate ID:	
Date Completed:	02-Jul-18	Customer:	Motorola Solutions Malaysia Sdn. Bhd. - 2A, Medan Bayan Lepas, Baymen Lepas Technoplex, 11900 Bayan Lepas, Pulau Pinang, Malaysia
Test Type:	Standard Field, Field Strength		

Calibration Uncertainty: Direct Field Method 1.15dB

k=2, (95% Confidence Level)

Test Remarks: Probe received in tolerance thus before and after data are the same.

Calibration Traceability: All Measuring and Test Equipment (MTE) identified below are traceable to the SI units through the National Institute for Standards and Technology (NIST) or other recognized National Metrology Institute. Calibration Laboratory and Quality System controls are compliant with ISO/IEC 17025-2005 and ANSI/NCSL Z540-1-1994.

Standards and Equipment Used:

Make / Model / Name / S/N / Recall Date				Condition of Instrument	
Keysight	33611A	Waveform Generator	MY53300266	03-Aug-18	Upon Receipt: In Tolerance to Internal Quality Standards
Keysight	34461A	DMM	MY53208622	04-Aug-18	
Agilent	E4440A	Spectrum Analyzer	MY45300879	28-Aug-18	On Release: In Tolerance to Internal Quality Standards
HP	8648C	Signal Generator	3836U02236	16-Mar-19	
Keysight	E9304A	Power Sensor	MY56100039	16-Mar-19	
Hewlett Packard	E4422B	Signal Generator	US40050591	09-Aug-18	
Agilent	E4419B	Power Meter	MY45104171	27-Jan-19	
Rohde & Schwarz	SMB 100A	Signal Generator	101558	13-Sep-18	
Agilent	E9304A	Power Sensor	MY41499013	16-Mar-19	
Agilent	E9304A	Power Sensor	MY41499012	16-Mar-19	
Rohde & Schwarz	NRP-Z91	Power Sensor	100733	26-Jan-19	
Agilent	E4419B	Power Meter	MY40510693	27-Jan-19	

Shawn Schmitt
 Calibration Completed By
 Shawn Schmitt, Calibration Technician

George Cisneros
 Attested and Issued on 02-Jul-18
 George Cisneros, Calibration Supervisor

This document provides traceability of measurements to recognized national standards using controlled processes at the ETS-Lindgren Calibration Laboratory. Uncertainties listed are derived from the methods described by NIST Tech Note 1297. This certificate and report may not be reproduced, except in full, without the written approval of ETS-Lindgren Calibration Laboratory in accordance with ISO/IEC 17025-2005 and ANSI/NCSL Z540-1-1994. The results in this document relate only to the item(s) listed and should not be considered representative of a population unless otherwise noted. OAF 1127 (03/11)

CALIBRATION REPORT

Magnetic Field Sensor

<i>Model</i>	<i>S/N</i>
H200	00206937
HI-2200	00086316

Date: 27 Jun 2018

- New Instrument
- Other
- Out of Tolerance
- Within Tolerance

Frequency Response

<i>Frequency Response</i>	<i>MHz</i>	<i>Nominal Field A/m</i>	<i>Cal Factor* (Eppfed/Endicated)</i>	<i>Deviation dB</i>
1	10	30	1.04	-0.30
2	15	30	1.01	-0.04
3	30	30	0.99	0.13
4	50	30	0.94	0.58
5	75	30	0.94	0.53
6	100	30	0.90	0.93
7	150	30	0.82	1.76
8	175	30	0.77	2.22
9	200	30	0.73	2.75
10	250	30	0.64	3.91
11	300	30	0.50	5.97

* Corrected magnetic field values (A/m) can be obtained by multiplying the Cal Factor with the indicated H field readings.

Linearity

maximum linearity deviation is 1.19 dB
 (measurements taken from 30 mA/m to 9 A/m at 27.12 MHz)

Test Conditions

Calibration performed at ambient room temperature: 23 ±3°C
 The above sensor was calibrated to factory specifications. This calibration is performed per IEEE 1309 standard. All equipment used are traceable to US National Institute of Standards and Technology (NIST).

Appendix C - Photos of Assessed Antennas
(All antennas mounted to the vehicle with magnetic mount base)

DVR

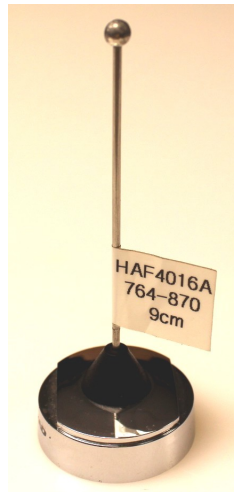

Antenna kit number
HAF4016A

Companion Mobile



All bands Antenna kit number
AN000131A01



**VHF Antenna kit numbers:
RAD4010ARB (6 pcs)**

Note: Antennas were trimmed per test frequency.



VHF Antenna kit numbers:
HAD4022A (6 pcs)

Note: Antennas were trimmed per test frequency.



**VHF Antenna kit numbers, from left to right;
HAD4016A, HAD4017A and HAD4021A**



**VHF Antenna kit numbers, from left to right;
HAD4009A, HAD4006A, HAD4007A and HAD4008A**



**UHF Antenna kit numbers, from left to right;
RAE4014ARB (3 pcs), RAE4015ARM (3 pcs)**

Note: Antennas were trimmed per test frequency (3 each).



**UHF Antenna kit numbers:
RAE4016ARB (3 pcs)**

Note: Antennas were trimmed per test frequency.



**UHF Antenna kit numbers, from left to right;
HAE4011A, HAE4012A, HAE4013A, HAE6011A and HAE6010A**



**UHF Antenna kit numbers, from left to right;
HAE6013A, HAE6031A and HAE6015A**



**UHF Antenna kit numbers, from left to right;
HAE6016A, HAE4004A, HAE4003A and HAE6012A**



**7/800 Antenna kit numbers, from left to right;
HAF4014A, HAF4017A, HAF4013A and HAF4016A**