

FCC PART 15.249



MEASUREMENT AND TEST REPORT

For

ActionTec Electronics, Inc.

760 North Mary Avenue  
Sunnyvale, CA 94085, USA

**FCC ID: LNQZCHAV1**

<b>Report Type:</b> <input checked="" type="checkbox"/> Original Report		<b>Product Type:</b> Home Automation Adapter	
<b>Test Engineer:</b>	Xiao Ming Hu 		
<b>Report Number:</b>	R0711198-249		
<b>Report Date:</b>	2007-11-28		
<b>Reviewed By:</b>	Hans Mellberg, VP of Engineering 		
<b>Prepared By:</b> (24)	Bay Area Compliance Laboratories Corp. (BACL) 1274 Anvilwood Ave Sunnyvale, CA 94089, USA Tel: (408) 732-9162 Fax: (408) 732 9164		

**Note:** This test report is for the customer shown above and their specific product only. It may not be duplicated or used in part without prior written consent from Bay Area Compliance Laboratories Corp. This report **must not** be used by the customer to claim product certification, approval, or endorsement by NVLAP, NIST, or any agency of the Federal Government.

## TABLE OF CONTENTS

<b>1</b>	<b>GENERAL INFORMATION</b> .....	<b>4</b>
1.1	PRODUCT DESCRIPTION FOR EQUIPMENT UNDER TEST (EUT).....	4
1.2	MECHANICAL DESCRIPTION.....	4
1.3	EUT PHOTO.....	4
1.4	OBJECTIVE.....	5
1.5	RELATED SUBMITTAL(S)/GRANT(S).....	5
1.6	TEST METHODOLOGY.....	5
1.7	MEASUREMENT UNCERTAINTY.....	5
1.8	TEST FACILITY.....	6
<b>2</b>	<b>SYSTEM TEST CONFIGURATION</b> .....	<b>7</b>
2.1	JUSTIFICATION.....	7
2.2	EUT EXERCISE SOFTWARE.....	7
2.3	EQUIPMENT MODIFICATIONS.....	7
2.4	SPECIAL ACCESSORIES.....	7
2.5	LOCAL SUPPORT EQUIPMENT.....	7
2.6	POWER SUPPLY INFORMATION.....	7
2.7	EXTERNAL I/O CABLING LIST AND DETAILS.....	7
2.8	TEST SETUP BLOCK DIAGRAMS.....	8
<b>3</b>	<b>SUMMARY OF TEST RESULTS</b> .....	<b>9</b>
<b>4</b>	<b>§15.203 - ANTENNA REQUIREMENT</b> .....	<b>10</b>
4.1	APPLICABLE STANDARD.....	10
4.2	ANTENNA CONNECTOR CONSTRUCTION.....	10
<b>5</b>	<b>§15.207 - CONDUCTED EMISSIONS</b> .....	<b>11</b>
5.1	SECTION 15.207 CONDUCTED LIMITS:.....	11
5.2	TEST SETUP.....	11
5.3	TEST EQUIPMENT LIST AND DETAILS.....	11
5.4	TEST PROCEDURE.....	11
5.5	SUMMARY OF TEST RESULTS.....	12
<b>6</b>	<b>§15.205 §15.209(A) §15.249(A) §15.249 - RADIATED EMISSIONS</b> .....	<b>15</b>
6.1	APPLICABLE STANDARD.....	15
6.2	TEST SETUP.....	16
6.3	EUT SETUP.....	16
6.4	TEST EQUIPMENT LIST AND DETAILS.....	16
6.5	TEST PROCEDURE.....	17
6.6	SUMMARY OF TEST RESULTS.....	18
6.7	RADIATED EMISSIONS DATA:.....	18
<b>7</b>	<b>§15.109 RECEIVER SPURIOUS EMISSION</b> .....	<b>19</b>
7.1	APPLICABLE STANDARD.....	19
7.2	TEST SETUP.....	19
7.3	EUT SETUP.....	19
7.4	TEST EQUIPMENT LIST AND DETAILS.....	19
7.5	TEST PROCEDURE.....	19
7.6	SUMMARY OF TEST RESULTS.....	20
7.7	RADIATED EMISSIONS DATA:.....	21
<b>8</b>	<b>EXHIBIT A – FCC PRODUCT LABEL</b> .....	<b>22</b>
8.1	FCC § 2.925 IDENTIFICATION OF EQUIPMENT.....	22
8.2	ID LABEL REQUIREMENTS AS PER FCC § 15.19.....	22
8.3	FCC ID LABEL.....	22
8.4	PROPOSED LABEL LOCATION ON EUT.....	23
<b>9</b>	<b>EXHIBIT B - TEST SETUP PHOTOGRAPHS</b> .....	<b>24</b>

9.1	CONDUCTED EMISSIONS –FRONT VIEW .....	24
9.2	CONDUCTED EMISSIONS – SIDE VIEW.....	24
9.3	RADIATED SPURIOUS EMISSIONS – FRONT VIEW .....	25
9.4	RADIATED SPURIOUS EMISSIONS – REAR VIEW .....	25
9.5	RECEIVER SPURIOUS EMISSIONS – FRONT VIEW.....	26
9.6	RECEIVER SPURIOUS EMISSIONS – REAR VIEW.....	26
<b>10</b>	<b>EXHIBIT C - EUT PHOTOGRAPHS.....</b>	<b>27</b>
10.1	EUT FRONT VIEW .....	27
10.2	EUT REAR VIEW .....	27
10.3	EUT TOP COVER OFF VIEW .....	28
10.4	AC POWER ADAPTOR .....	28
10.5	EUT MAIN BOARD COMPONENT VIEW.....	29
10.6	EUT MAIN BOARD SIDE VIEW 1.....	29
10.7	EUT MAIN BOARD SIDE VIEW 2.....	30
10.8	EUT MAIN BOARD SOLDER VIEW .....	30

## 1 GENERAL INFORMATION

### 1.1 Product Description for Equipment under Test (EUT)

This measurement and test report has been compiled on behalf of the company *ActionTec Electronics, Inc.* and their product, Trade Name: zControl Home Adapter, model: ZCHAV1, FCC ID: LNQZCHAV1 which will be henceforth in this report referred to as the EUT (Equipment under Test).

The EUT is a home automation, monitoring and remote management adapter. It is designed with thoughts of future integration into Actiontec's routers and gateways in mind. The EUT uses the Broadcom BCM6358 chipset and includes feature such as USB 2.0 Host support and LAN Ethernet PHY. It is equipped with 8MB flash memory for firmware and bootloader storage access, as well as a 32MB DDR-RAM for applications.

The ZM3102N Z-Wave Module installed on the EUT is a fully integrated RF communication module that uses the unlicensed Short-Range- Device (SRD) frequency band of 902MHz - 928MHz in US. The ZM3102N is dedicated for wireless control and monitoring of residential products like lighting and appliance control, energy management, access control, security and building automation.

*\* All test data gathered is from a production sample, serial number: B1417, assigned by BACL.*

### 1.2 Mechanical Description

The EUT is a of plastic construction that measures approximately 10.8 cm (L) x 3.8 cm (W) x 16.51 cm (H) and weighs approximately 14.5 g. It is typically powered by 12VDC with an AC Power Adapter.

### 1.3 EUT Photo



*Please see additional photos in exhibit C*

## 1.4 Objective

This type approval report is prepared on behalf of *ActionTec Electronics, Inc.* in accordance with Part 2, Subpart J, Part 15, Subparts A, B and C of the Federal Communication Commissions rules.

The objective is to determine compliance with FCC rules for section 15.203, 15.205, 15.207, 15.209 and 15.249.

## 1.5 Related Submittal(s)/Grant(s)

No Related Submittals

## 1.6 Test Methodology

All measurements contained in this report were conducted in accordance with ANSI C63.4-2003, American National Standard for Methods of Measurement of Radio-Noise Emissions from Low-Voltage Electrical and Electronic Equipment in the range of 9 kHz to 40 GHz.

## 1.7 Measurement Uncertainty

All measurements involve certain levels of uncertainties, especially in field of EMC. The factors contributing to uncertainties are spectrum analyzer, cable loss, antenna factor calibration, antenna directivity, antenna factor variation with height, antenna phase center variation, antenna factor frequency interpolation, measurement distance variation, site imperfections, mismatch (average), and system repeatability.

Based on NIS 81, The Treatment of Uncertainty in EMC Measurements, the values range from  $\pm 2.0$  for Conducted Emissions tests and  $\pm 4.0$  dB for Radiated Emissions tests are the most accurate estimates pertaining to uncertainty of EMC measurements at BAACL.

Detailed instrumentation measurement uncertainties can be found in BAACL report QAP-018.

All radiated and conducted emissions measurement was performed at Bay Area Compliance Laboratory, Corp. The radiated testing was performed at an antenna-to-EUT distance of 3 meters.

## 1.8 Test Facility

The test site used by BACL Corp. to collect radiated and conducted emissions measurement data is located at its facility in Sunnyvale, California, USA.

The test sites at BACL have been fully described in reports submitted to the Federal Communication Commission (FCC) and Voluntary Control Council for Interference (VCCI). The details of these reports has been found to be in compliance with the requirements of Section 2.948 of the FCC Rules on February 11 and December 10, 1997 and Article 8 of the VCCI regulations on December 25, 1997. The facility also complies with the radiated and AC line conducted test site criteria set forth in ANSI C63.4-2003.

The Federal Communications Commission, Industry Canada, and Voluntary Control Council for Interference has the reports on file and is listed under FCC registration number: 90464, IC registration number: 3062A, and VCCI Registration Number: C-2463 and R-2698. The test site has been approved by the FCC, IC, and VCCI for public use and is listed in the FCC Public Access Link (PAL) database.

Additionally, BACL is a National Institute of Standards and Technology (NIST) accredited laboratory, under the National Voluntary Laboratory Accredited Program (Lab Code 200167-0). The current scope of accreditations can be found at <http://ts.nist.gov/Standards/scopes/2001670.htm>



---

## 2 SYSTEM TEST CONFIGURATION

---

### 2.1 Justification

The EUT was configured for testing according to ANSI C63.4-2003.

The EUT was tested in the testing mode to represent *worst*-case results during the final qualification test.

### 2.2 EUT Exercise Software

The Software to Exercise the EUT was provided by the customer.

### 2.3 Equipment Modifications

No modifications were made to the EUT.

### 2.4 Special Accessories

No special accessories used during testing.

### 2.5 Local Support Equipment

No Local Support Equipment used during testing.

### 2.6 Power Supply Information

Manufacturer	Description	Model	Serial Number
ActionTec	AC Power Adaptor	AD-1260	-

### 2.7 External I/O Cabling List and Details

None

## 2.8 Test Setup Block Diagrams

### 2.8.1 Conducted Emission

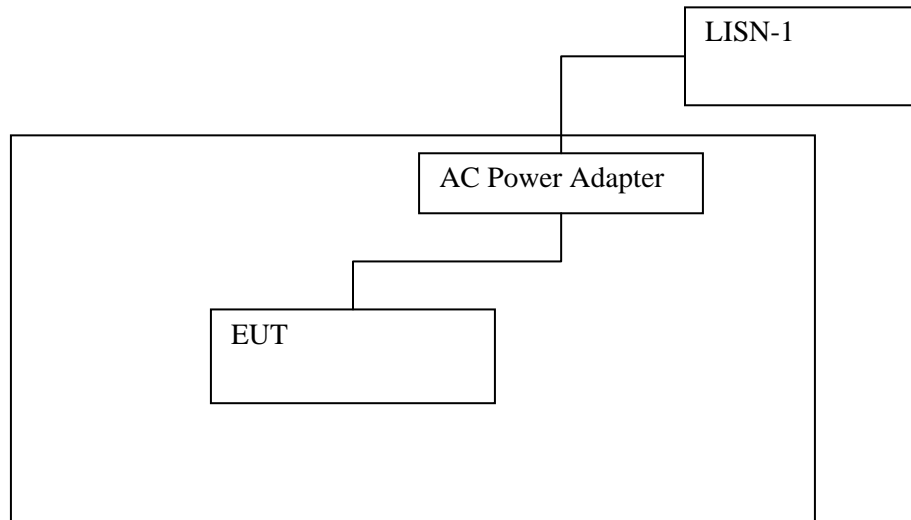

### 2.8.2 Radiated Emissions

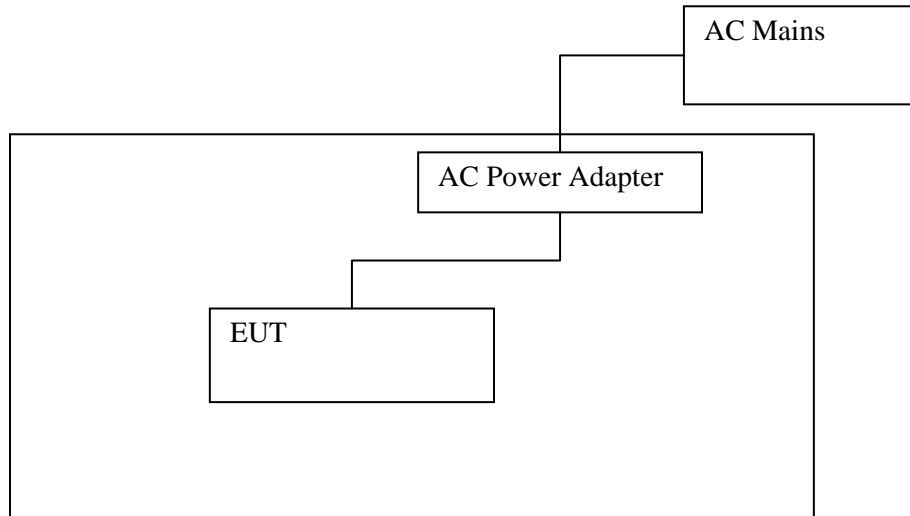



### 3 SUMMARY OF TEST RESULTS

Results reported relate only to the product tested.

FCC Rules	Description of Test	Result
§15.203	Antenna Requirement	Compliant
§15.207(a)	Conduction Emissions	Compliant
§15.205(a), §15.209(a) §15.249(a), §15.249(d)	Radiated Emissions	Compliant
§15.109	Receiver Spurious Emission	Compliant

---

## **4 §15.203 - ANTENNA REQUIREMENT**

---

### **4.1 Applicable Standard**

According to § 15.203, an intentional radiator shall be designed to ensure that no antenna other than that furnished by the responsible party shall be used with the device. The use of a permanently attached antenna or of an antenna that uses a unique coupling to the intentional radiator shall be considered sufficient to comply with the provisions of this Section. The manufacturer may design the unit so that a broken antenna can be replaced by the user, but the use of a standard antenna jack or electrical connector is prohibited.

And according to § 15.247 (b) (4), if transmitting antennas of directional gain greater than 6 dBi are used the power shall be reduced by the amount in dB that the directional gain of the antenna exceeds 6 dBi.

### **4.2 Antenna Connector Construction**

The EUT antenna is integrated into the PCB construction, which in accordance to section 15.203, is considered sufficient to comply with the provisions of this section.

**Result:** Compliant.

## 5 §15.207 - CONDUCTED EMISSIONS

### 5.1 Section 15.207 Conducted limits:

For an intentional radiator that is designed to be connected to the public utility (AC) power line, the radio frequency voltage that is conducted back onto the AC power line on any frequency or frequencies within the band 150 kHz to 30 MHz shall not exceed the limits in the following table, as measured using a 50  $\mu$ H/50 ohms line impedance stabilization network (LISN). Compliance with the provisions of this paragraph shall be based on the measurement of the radio frequency voltage between each power line and ground at the power terminal. The lower limit applies at the boundary between the frequencies ranges.

Frequency of Emission (MHz)	Conducted Limit (dBuV)	
	Quasi-peak	Average
0.15-0.5	66 to 56 *	56 to 46 *
0.5-5	56	46
5-30	60	50

\* Decreases with the logarithm of the frequency.

### 5.2 Test Setup

The measurement was performed at shield room, using the setup per ANSI C63.4 – 2003 measurement procedure. The specification used was FCC Class B limits.

External I/O cables were draped along the edge of the test table and bundle when necessary.

The EUT was connected with LISN-1 as powered by connection to 120 V/ 60 Hz AC mains

### 5.3 Test Equipment List and Details

Manufacturer	Description	Model	Serial Number	Calibration Date
Rohde & Schwarz	EMI Test Receiver	ESCI 1166.5950 K03	100337	2007-03-08
Solar Electronics Co.	LISN	9252-50-R-24- N	0511213	2007-07-31

\* **Statement of Traceability: BACL Corp.** attests that all calibrations have been performed per the NVLAP requirements, traceable to the NIST.

### 5.4 Test Procedure

During the conducted emissions test, the power cord of the EUT was connected to the mains outlet of the LISN-1.

Maximization procedure was performed on the six (6) highest emissions of the EUT.

All data was recorded in the peak detection mode, quasi-peak and average. Quasi-Peak readings are distinguished with a “QP”. Average readings are distinguished with an “Ave”.

### Environmental Conditions

<b>Temperature:</b>	20 °C
<b>Relative Humidity:</b>	41 %
<b>ATM Pressure:</b>	101.5 kPa

*\*The testing was performed by Xiao Ming Hu on 2007-11-27.*

### 5.5 Summary of Test Results

According to the recorded data in following table, the EUT complied with the FCC standard's conducted emissions limits for Class B devices, with the *worst* margin reading of:

<b>Connection: 120 V/60 Hz AC</b>			
<b>Margin (dB)</b>	<b>Frequency (MHz)</b>	<b>Conductor Mode (Hot/Neutral)</b>	<b>Range (MHz)</b>
-17.2	0.478500	Hot	0.150 to 30

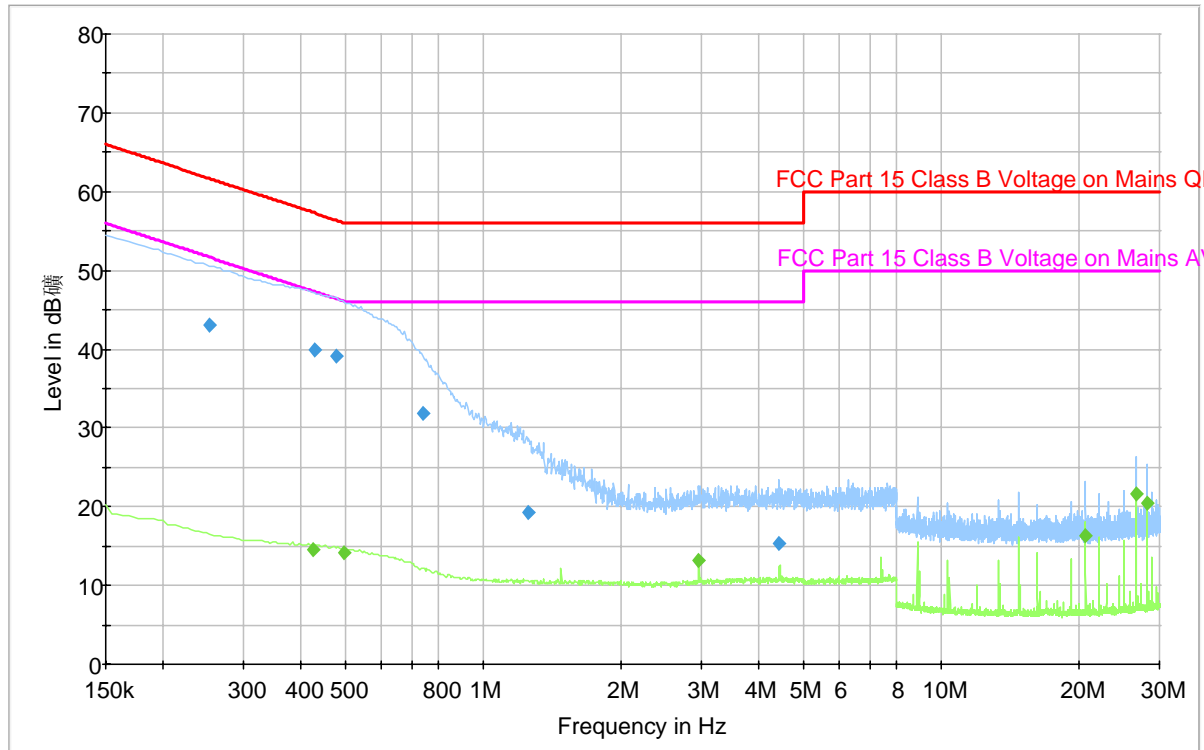
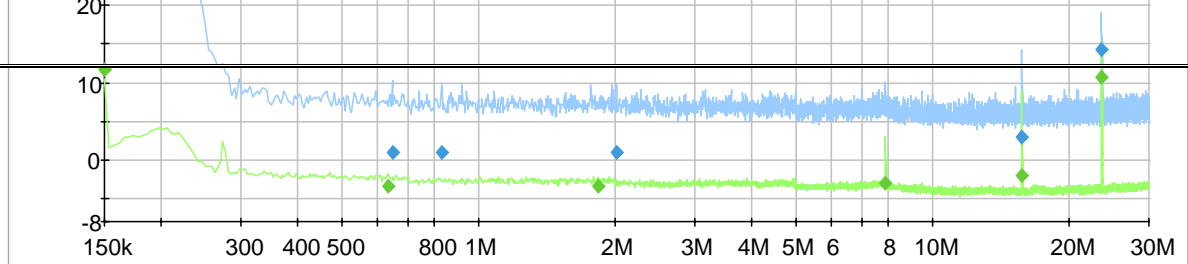

### Quasi-Peak Measurements

Frequency (MHz)	Quasi-peak (dB $\mu$ V)	Conduction (Hot/ Neutral)	Limit (dB $\mu$ V)	Margin (dB)
0.478500	39.2	Hot	56.4	-17.2
0.429000	39.9	Hot	57.3	-17.4
0.253500	43.0	Hot	61.6	-18.7
0.739500	31.9	Hot	56.0	-24.1
1.257000	19.3	Hot	56.0	-36.7
4.434000	15.3	Hot	56.0	-40.7

### Average Measurements

Frequency (MHz)	Average (dB $\mu$ V)	Conduction (Hot/ Neutral)	Limit (dB $\mu$ V)	Margin (dB)
26.641500	21.5	Hot	50.0	-28.5
28.122000	20.4	Hot	50.0	-29.6
0.496500	14.1	Hot	46.1	-31.9
0.424500	14.6	Hot	47.4	-32.8
2.962500	13.1	Hot	46.0	-32.9
20.724000	16.3	Hot	50.0	-33.7

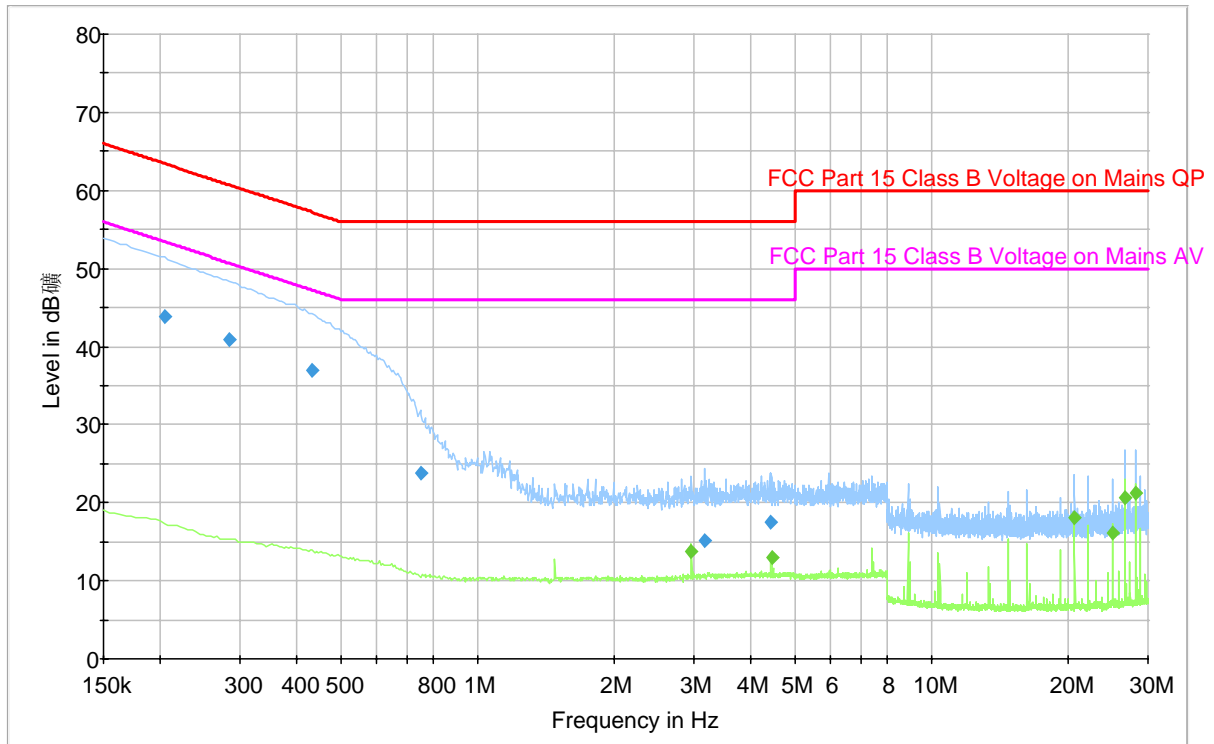
**120 V, 60 Hz – Neutral****Quasi-peak Measurements**

Frequency (MHz)	Quasi-peak (dBµV)	Conduction (Hot/ Neutral)	Limit (dBµV)	Margin (dB)
0.204000	43.9	Neutral	63.4	-19.5
0.285000	40.9	Neutral	60.7	-19.8
0.433500	37.0	Neutral	57.2	-20.2
0.748500	23.7	Neutral	56.0	-32.3
4.438500	17.6	Neutral	56.0	-38.4
3.169500	15.2	Neutral	56.0	-40.8

**Average Measurements**

Frequency (MHz)	Average (dBµV)	Conduction (Hot/ Neutral)	Limit (dBµV)	Margin (dB)
28.126500	21.3	Neutral	50.0	-28.7
26.646000	20.7	Neutral	50.0	-29.3
20.724000	18.0	Neutral	50.0	-32.0
2.962500	13.8	Neutral	46.0	-32.2
4.443000	12.9	Neutral	46.0	-33.1
25.165500	16.2	Neutral	50.0	-33.8

## 6 §15.205 §15.209(a) §15.249(a) §15.249 - RADIATED EMISSIONS

### 6.1 Applicable Standard

As per 15.35(d): Unless otherwise specified, on any frequency or frequencies above 1000 MHz, the radiated emission limits are based on the use of measurement instrumentation employing an average detector function. Unless otherwise specified, measurements above 1000 MHz shall be performed using a minimum resolution bandwidth of 1 MHz.

As per 15.209(a): Except as provided elsewhere in this Subpart, the emissions from an intentional radiator shall not exceed the field strength levels specified in the following table

Frequency (MHz)	Field Strength (micro volts/meter)	Measurement Distance (meters)
0.009 - 0.490	2400/F(kHz)	300
0.490 - 1.705	24000/F(kHz)	30
1.705 - 30.0	30	30
30 - 88	100**	3
88 - 216	150**	3
216 - 960	200**	3
Above 960	500	3

\*\* Except as provided in paragraph (g), fundamental emissions from intentional radiators operating under this Section shall not be located in the frequency bands 54-72 MHz, 76-88 MHz, 174-216 MHz or 470-806 MHz. However, operation within these frequency bands is permitted under other sections of this Part, e.g., Sections 15.231 and 15.241.

As Per 15.205(a) except as show in paragraph (d) of this section, only spurious emissions are permitted in any of the frequency bands listed below:

MHz	MHz	MHz	GHz
0.090 – 0.110	16.42 – 16.423	960 – 1240	4.5 – 5.15
0.495 – 0.505	16.69475 – 16.69525	1300 – 1427	5.35 – 5.46
2.1735 – 2.1905	25.5 – 25.67	1435 – 1626.5	7.25 – 7.75
4.125 – 4.128	37.5 – 38.25	1645.5 – 1646.5	8.025 – 8.5
4.17725 – 4.17775	73 – 74.6	1660 – 1710	9.0 – 9.2
4.20725 – 4.20775	74.8 – 75.2	1718.8 – 1722.2	9.3 – 9.5
6.215 – 6.218	108 – 121.94	2200 – 2300	10.6 – 12.7
6.26775 – 6.26825	123 – 138	2310 – 2390	13.25 – 13.4
6.31175 – 6.31225	149.9 – 150.05	2483.5 – 2500	14.47 – 14.5
8.291 – 8.294	156.52475 – 156.52525	2690 – 2900	15.35 – 16.2
8.362 – 8.366	156.7 – 156.9	3260 – 3267	17.7 – 21.4
8.37625 – 8.38675	162.0125 – 167.17	3.332 – 3.339	22.01 – 23.12
8.41425 – 8.41475	167.72 – 173.2	3 3458 – 3 358	23.6 – 24.0
12.29 – 12.293	240 – 285	3.600 – 4.400	31.2 – 31.8
12.51975 – 12.52025	322 – 335.4		36.43 – 36.5
12.57675 – 12.57725	399.9 – 410		Above 38.6
13.36 – 13.41	608 – 614		

As Per 15.249(a), except as provided in paragraph (b) of this section, the field strength of emissions from intentional radiators operated within these frequency bands shall comply with the following:

Fundamental frequency	Field strength of fundamental (millivolts/meter)	Field strength of harmonics (microvolts/meter)
902–928 MHz	50	500
2400–2483.5 MHz	50	500
5725–5875 MHz	50	500
24.0–24.25 GHz	250	2500

(d) Emissions radiated outside of the specified frequency bands, except for harmonics, shall be attenuated by at least 50 dB below the level of the fundamental or to the general radiated emission limits in §15.209, whichever is the lesser attenuation

## 6.2 Test Setup

The radiated emissions tests were performed in the 3-meter open area test site, using the setup in accordance with ANSI C63.4-2003. The specification used was the FCC 15 Subpart C limits.

## 6.3 EUT Setup

The radiated emissions tests were performed using the setup accordance with the ANSI C63.4-2003. The specification used was the FCC 15C limits.

The spacing between the peripherals was 10 centimeters.

External I/O cables were draped along the edge of the test table and bundled when necessary.

## 6.4 Test Equipment List and Details

Manufacturer	Description	Model	Serial Number	Cal. Date
HP	Amplifier, Pre (.1~1300MHz)	8447D	2944A10198	2007-01-20
Rohde & Schwarz	EMI Test Receiver	ESCI 1166.5950 K03	100337	2007-03-08
DRG	Horn Antenna	SAS-200/571	261	2007-06-07
Sunol Sciences	30MHz~2GHz Antenna	JB1	A03105-3	2007-03-15
Agilent	Spectrum analyzer	8565EC	3946A00131	2007-01-24
Agilent	Pre amplifier	8449B	3008A01978	2007-08-21

**\*Statement of Traceability:** BACL attests that all calibrations have been performed per the NVLAP requirements, traceable to NIST.



## 6.5 Test Procedure

For the radiated emissions test, the EUT, and all support equipment power cords was connected to the AC floor outlet.

Maximizing procedure was performed on the highest emissions to ensure that the EUT complied with all installation combinations.

The EUT is set 3 meter away from the testing antenna, which is varied from 1-4 mete, and the EUT is placed on a turntable, which is 0.8 meter above ground plane, the table shall be rotated for 360 degrees to find out the highest emission. The receiving antenna should be changed the polarization both of horizontal and vertical.

The spectrum analyzer or receiver is set as:

Below 1000MHz:

$$\text{RBW} = 100 \text{ kHz} / \text{VBW} = 300 \text{ kHz} / \text{Sweep} = \text{Auto}$$

Above 1000MHz:

- (1) Peak: RBW = 1MHz / VBW = 1MHz / Sweep = Auto
- (2) Average: RBW = 1MHz / VBW = 10Hz / Sweep = Auto

### Corrected Amplitude & Margin Calculation

The Corrected Amplitude is calculated by adding the Antenna Factor and Cable Factor, and subtracting the Amplifier Gain from the Amplitude reading. The basic equation is as follows:

$$\text{Corrected Amplitude} = \text{Indicated Reading} + \text{Antenna Factor} + \text{Cable Factor} - \text{Amplifier Gain}$$

The “**Margin**” column of the following data tables indicates the degree of compliance with the applicable limit. For example, a margin of -7dB means the emission is 7dB below the maximum limit.

The equation for margin calculation is as follows:

$$\text{Margin} = \text{Corrected Amplitude} - \text{FCC Limit}$$

### Environmental Conditions

<b>Temperature:</b>	20 °C
<b>Relative Humidity:</b>	41 %
<b>ATM Pressure:</b>	101.5 kPa

*Testing was performed by Xiao Ming Hu on 2007-11-27.*

## 6.6 Summary of Test Results

According to the data hereinafter, the EUT complied with the limits presented in FCC Title 47, Part 15, Subpart C, section 15.205, 15.209 and 15.249, and had the worst margin of:

Mode: Transmitting			
Margin (dB)	Frequency (MHz)	Polarization (Horizontal/Vertical)	Test Range (GHz)
-12.2	908.4	Vertical	1 – 10

## 6.7 Radiated Emissions data:

Measured at 3 meters

Freq. (MHz)	Meter Reading (dBuV)	Detector PK/QP/AV	Azimuth Degree	Height (m)	Polar. H / V	Antenna Factor (dB/m)	Cable Loss (dB)	Pre-Amp. Gain (dB)	Correction Amp. (dBuV/m)	FCC Part 15.249/15.209		
										Limit (dBuV/m)	Margin (dB)	Comment
908.4000	85.7	Peak	0	1.0	v	22.6	2.4	27.1	83.6	113.97	-30.4	Fund/Peak
908.4000	83.3	Peak	93	1.0	h	22.6	2.4	27.1	81.2	113.97	-32.8	Fund/Peak
908.4000	83.8	Ave	0	1.0	v	22.6	2.4	27.1	81.7	93.97	-12.2	Fund /Ave
908.4000	81.7	Ave	93	1.0	h	22.6	2.4	27.1	79.6	93.97	-14.4	Fund /Ave
1816.8000	54.3	Peak	0	1.2	v	24.8	2.5	35.9	45.7	74	-28.3	Peak
1816.8000	51.0	Peak	94	1.0	h	24.8	2.5	35.9	42.4	74	-31.6	Peak
1816.8000	45.2	Ave	0	1.2	v	24.8	2.5	35.9	36.6	54	-17.4	Ave
1816.8000	38.7	Ave	94	1.0	h	24.8	2.5	35.9	30.1	54	-23.9	Ave
2725.2000	52.2	Peak	0	1.0	v	28.9	2.8	35.1	48.8	74	-25.2	Peak
2725.2000	52.5	Peak	92	1.0	h	28.9	2.8	35.1	49.2	74	-24.8	Peak
2725.2000	39.8	Ave	0	1.0	v	28.9	2.8	35.1	36.5	54	-17.5	Ave
2725.2000	39.5	Ave	92	1.0	h	28.9	2.8	35.1	36.2	54	-17.8	Ave

## 7 §15.109 Receiver Spurious Emission

### 7.1 Applicable Standard

(a) Except for Class A digital devices, the field strength of radiated emissions from unintentional radiators at a distance of 3 meters shall not exceed the following values:

Frequency of emission (MHz)	Field strength of fundamental (millivolts/meter)
30-88	100
88-216	150
216-960	200
Above 960	500

### 7.2 Test Setup

The radiated emissions tests were performed in the 3-meter open area test site, using the setup in accordance with ANSI C63.4-2003. The specification used was the FCC 15 Subpart C limits.

### 7.3 EUT Setup

The radiated emissions tests were performed using the setup accordance with the ANSI C63.4-2003. The specification used was the FCC 15C limits.

The spacing between the peripherals was 10 centimeters.

External I/O cables were draped along the edge of the test table and bundle when necessary.

### 7.4 Test Equipment List and Details

Manufacturer	Description	Model	Serial Number	Cal. Date
HP	Amplifier, Pre (.1~1300MHz)	8447D	2944A10198	2007-01-20
Rohde & Schwarz	EMI Test Receiver	ESCI 1166.5950 K03	100337	2007-03-08
Sunol Science Corp	Combination Antenna	JB3 Antenna	A020106-3	2007-03-05

**Statement of Traceability:** BACL attests that all calibrations have been performed per the NVLAP requirements, traceable to NIST.

### 7.5 Test Procedure

For the radiated emissions test, the EUT, and all support equipment power cords was connected to the AC floor outlet.

Maximizing procedure was performed on the highest emissions to ensure that the EUT complied with all

installation combinations.

The EUT is set 3 meter away from the testing antenna, which is varied from 1-4 meters, and the EUT is placed on a turntable, which is 0.8 meter above ground plane, the table shall be rotated for 360 degrees to find out the highest emission. The receiving antenna should be changed the polarization both of horizontal and vertical.

The spectrum analyzer or receiver is set as:

Below 1000MHz:

$$\text{RBW} = 100 \text{ kHz} / \text{VBW} = 300 \text{ kHz} / \text{Sweep} = \text{Auto}$$

### Corrected Amplitude & Margin Calculation

The Corrected Amplitude is calculated by adding the Antenna Factor and Cable Factor, and subtracting the Amplifier Gain from the Amplitude reading. The basic equation is as follows:

$$\text{Corrected Amplitude} = \text{Indicated Reading} + \text{Antenna Factor} + \text{Cable Factor} - \text{Amplifier Gain}$$

The “**Margin**” column of the following data tables indicates the degree of compliance with the applicable limit. For example, a margin of -7dB means the emission is 7dB below the maximum limit. The equation for margin calculation is as follows:

$$\text{Margin} = \text{Corrected Amplitude} - \text{FCC Limit}$$

### Environmental Conditions

<b>Temperature:</b>	20 °C
<b>Relative Humidity:</b>	41 %
<b>ATM Pressure:</b>	101.5 kPa

Testing was performed by Xiao Ming Hu on 2007-11-12.

## 7.6 Summary of Test Results

According to the data hereinafter, the EUT complied with the limits presented in FCC Title 47, Part 15, Subpart B, section 15.109, and had the worst margin of:

<b>Mode: Receiving</b>			
<b>Margin (dB)</b>	<b>Frequency (MHz)</b>	<b>Polarization (Horizontal/Vertical)</b>	<b>Test Range (MHz)</b>
-6.7	110.812500	Vertical	30-1000

**7.7 Radiated Emissions data:**

Measured at 3 meters

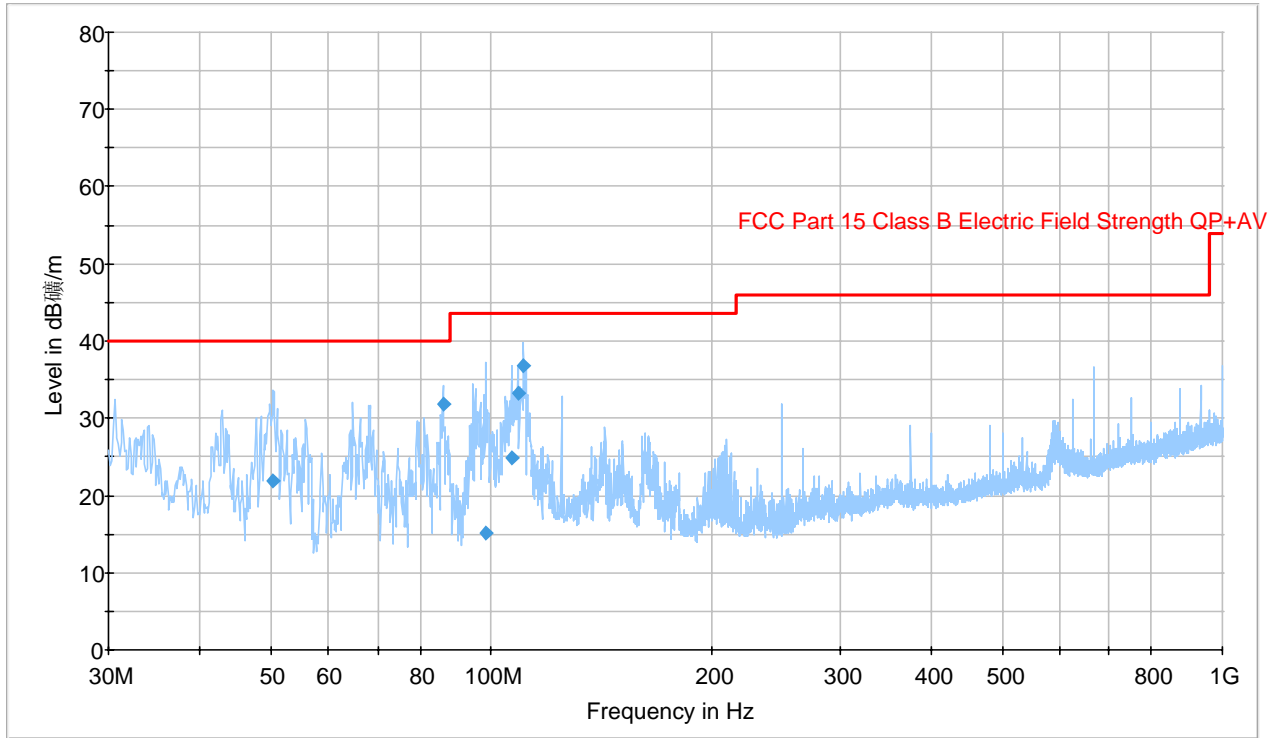

**Quasi-Peak Measurements:**

Frequency (MHz)	Quasi-Peak (dBµV/m)	Antenna Height (cm)	Polarity (H/V)	Turntable Position (deg)	Limit (dBµV/m)	Margin (dB)
110.812500	36.8	101.0	V	136.0	43.5	-6.7
86.077500	31.9	112.8	V	25.0	40.0	-8.1
108.812500	33.3	100.7	V	136.0	43.5	-10.2
50.430000	21.9	276.0	V	307.0	40.0	-18.1
106.690000	24.8	100.6	V	171.0	43.5	-18.7
98.446250	15.0	100.7	V	171.0	43.5	-28.5