

MEASUREMENT REPORT

FCC PART 15.407/ WLAN 802.11a/n/ac/ax

FCC ID: LNQWEB7200
Applicant: Actiontec Electronics Inc
Application Type: Certification
Product: WiFi 6 Extender
Model No.: WEB7200
Brand Name: Actiontec
FCC Classification: Unlicensed National Information Infrastructure (NII)
FCC Rule Part(s): Part15 Subpart E (Section 15.407)
Test Procedure(s): ANSI C63.10-2013, KDB 789033 D02v02r01
KDB 662911 D01v02r01
Test Date: April 20 ~ June 08, 2021

Reviewed By:



Sunny Sun

Approved By:

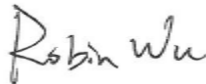

Robin Wu



The test results relate only to the samples tested.

This equipment has been shown to be capable of compliance with the applicable technical standards as indicated in the measurement report and was tested in accordance with the measurement procedures specified in KDB 789033 D02v02r01. Test results reported here in relate only to the item(s) tested.

The test report shall not be reproduced except in full without the written approval of MRT Technology (Suzhou) Co., Ltd.

Revision History

Report No.	Version	Description	Issue Date	Note
2102RSU047-U3	Rev. 01	Initial Report	07-08-2021	Valid

CONTENTS

Description	Page
1. General Information.....	5
1.1. Applicant.....	5
1.2. Manufacturer	5
1.3. Testing Facility	5
1.4. Product Information	6
1.5. Radio Specification under Test.....	6
1.6. Description of Available Antennas	7
1.7. Working Frequencies for this Report.....	7
1.8. Test Mode	8
1.9. Configuration of Test System.....	8
1.10. Test System Details.....	9
1.11. Duty Cycle	9
1.12. Description of Test Software	11
1.13. EMI Suppression Device(s)/Modifications	11
1.14. Test Environment Condition	11
2. ANTENNA REQUIREMENTS.....	12
3. TEST EQUIPMENT CALIBRATION DATE	13
4. MEASUREMENT UNCERTAINTY.....	18
5. TEST RESULT	19
5.1. Summary	19
5.2. 26dB Bandwidth Measurement.....	20
5.2.1. Test Limit	20
5.2.2. Test ProcedureUsed	20
5.2.3. Test Setting.....	20
5.2.4. Test Setup	20
5.2.5. Test Result.....	21
5.3. 6dB Bandwidth Measurement.....	39
5.3.1. Test Limit	39
5.3.2. Test Procedure Used	39
5.3.3. TestSetting.....	39
5.3.4. Test Setup	39
5.3.5. TestResult.....	40
5.4. Output Power Measurement.....	46
5.4.1. Test Limit	46
5.4.2. Test Procedure Used	46

5.4.3. Test Setting.....	46
5.4.4. Test Setup	46
5.4.5. Test Result.....	47
5.5. Transmit Power Control	51
5.5.1. Test Limit	51
5.5.2. Test Procedure Used	51
5.5.3. Test Setting.....	51
5.5.4. Test Setup	51
5.5.5. Test Result.....	51
5.6. Power Spectral Density Measurement	52
5.6.1. TestLimit	52
5.6.2. Test Procedure Used	52
5.6.3. Test Setting.....	52
5.6.4. Test Setup	53
5.6.5. Test Result.....	54
5.7. Radiated Spurious Emission Measurement	84
5.7.1. Test Limit	84
5.7.2. Test Procedure Used	84
5.7.3. Test Setting.....	84
5.7.4. Test Setup	86
5.7.5. Test Result.....	87
5.8. Radiated RestrictedBand Edge Measurement	160
5.8.1. Test Limit	160
5.8.2. Test Procedure Used	161
5.8.3. Test Setting.....	161
5.8.4. Test Setup	162
5.8.5. Test Result.....	163
5.9. AC Conducted Emissions Measurement.....	285
5.9.1. Test Limit	285
5.9.2. Test Setup	285
5.9.3. Test Result.....	286
6. CONCLUSION.....	288
Appendix A - Test Setup Photograph	289
Appendix B - EUT Photograph.....	290

1.4. Product Information

Product Name	WiFi 6 Extender
Model No.	WEB7200
Brand Name	Actiontec
Operating Temperature	0 ~ 40°C
Wi-Fi Specification	802.11a/b/g/n/ac/ax
Antenna Information	Refer to section 1.6
Accessories	
AC/DC Adapter 1#	Model: MS-V1500R120-018H0-US Input: 100-240V ~ 50/60Hz, 0.6A MAX Output: 12V, 1.5A
AC/DC Adapter 2#	Model: RD1201500-C55-153MG Input: 100-240V ~ 50-60Hz 0.6A Output: 12V, 1.5A
AC/DC Adapter 3#	Model: ADS024T-W 120150 Input: 100-240V ~ 50-60Hz 0.6A Output: 12V, 1.5A

1.5. Radio Specification under Test

Frequency Range:	For 802.11a/n-HT20/ac-VHT20/ax-HE20: 5180 ~ 5240MHz, 5260 ~ 5320MHz, 5500 ~ 5720MHz, 5745 ~ 5825MHz For 802.11n-HT40/ac-VHT40/ax-HE40: 5190 ~ 5230MHz, 5270 ~ 5310MHz, 5510 ~ 5710MHz, 5755 ~ 5795MHz For 802.11ac-VHT80/ax-HE80: 5210MHz, 5290MHz, 5530MHz, 5610MHz, 5690MHz, 5775MHz
Type of Modulation:	802.11a/n/ac: OFDM 802.11ax: OFDMA
Data Rate:	802.11a: 6/9/12/18/24/36/48/54Mbps 802.11n: up to 300Mbps 802.11ac: up to 866.6Mbps 802.11ax: up to 1201Mbps

1.6. Description of Available Antennas

Antenna Type	Ant Port	Frequency Band (GHz)	T _x Paths	Antenna Gain (dBi)	Directional Gain (dBi)	
					For Power	For PSD
PCB Antenna	DB1	2.4 ~ 2.5	2	4.56	4.56	7.57
	DB2	5.1 ~ 5.85		4.32	4.32	7.33
Onboard Metal DFS Antenna	DFS	5.1 ~ 5.85	N/A	4.32	--	--

Remark:

1. The EUT supports Cyclic Delay Diversity (CDD) mode.
2. The information of EUT was provided by the manufacturer, and the accuracy of the information shall be the responsibility of the manufacturer.
3. Onboard Metal DFS Antenna only for receive to detect radar signals.

1.7. Working Frequencies for this Report

802.11a/n-HT20/ac-VHT20/ax-HE20

Channel	Frequency	Channel	Frequency	Channel	Frequency
36	5180 MHz	40	5200 MHz	44	5220 MHz
48	5240 MHz	52	5260 MHz	56	5280 MHz
60	5300 MHz	64	5320 MHz	100	5500 MHz
104	5520 MHz	108	5540 MHz	112	5560 MHz
116	5580 MHz	120	5600 MHz	124	5620 MHz
128	5640 MHz	132	5660 MHz	136	5680 MHz
140	5700 MHz	144	5720 MHz	149	5745 MHz
153	5765 MHz	157	5785 MHz	161	5805 MHz
165	5825 MHz	--	--	--	--

802.11n-HT40/ac-VHT40/ax-HE40

Channel	Frequency	Channel	Frequency	Channel	Frequency
38	5190 MHz	46	5230 MHz	54	5270 MHz
62	5310 MHz	102	5510 MHz	110	5550 MHz
118	5590 MHz	126	5630 MHz	134	5670 MHz
142	5710 MHz	151	5755 MHz	159	5795 MHz

802.11ac-VHT80/ax-HE80

Channel	Frequency	Channel	Frequency	Channel	Frequency
42	5210 MHz	58	5290 MHz	106	5530 MHz
122	5610 MHz	138	5690 MHz	155	5775 MHz

1.8. Test Mode

Test Mode	Mode 1: Transmit by 802.11a (6Mbps)
	Mode 2: Transmit by 802.11n-HT20 (MCS0)
	Mode 3: Transmit by 802.11ac-VHT20 (MCS0)
	Mode 4: Transmit by 802.11ac-VHT40 (MCS0)
	Mode 5: Transmit by 802.11ac-VHT80 (MCS0)
	Mode 6: Transmit by 802.11ax-HE20 (MCS0)
	Mode 7: Transmit by 802.11ax-HE40 (MCS0)
	Mode 8: Transmit by 802.11ax-HE80 (MCS0)

Note: Due to the same modulation between 802.11n and 802.11ac, so 802.11n-HT20 and HT40 are covered by 802.11ac-VHT20 and VHT40 in this report, meanwhile, power setting for 802.11n-HT20 and HT40 will not be greater than 802.11ac-VHT20 and VHT40.

1.9. Configuration of Test System

The device was tested per the guidance ANSI C63.10: 2013 was used to reference the appropriate EUT setup for radiated emissions testing and AC line conducted testing.

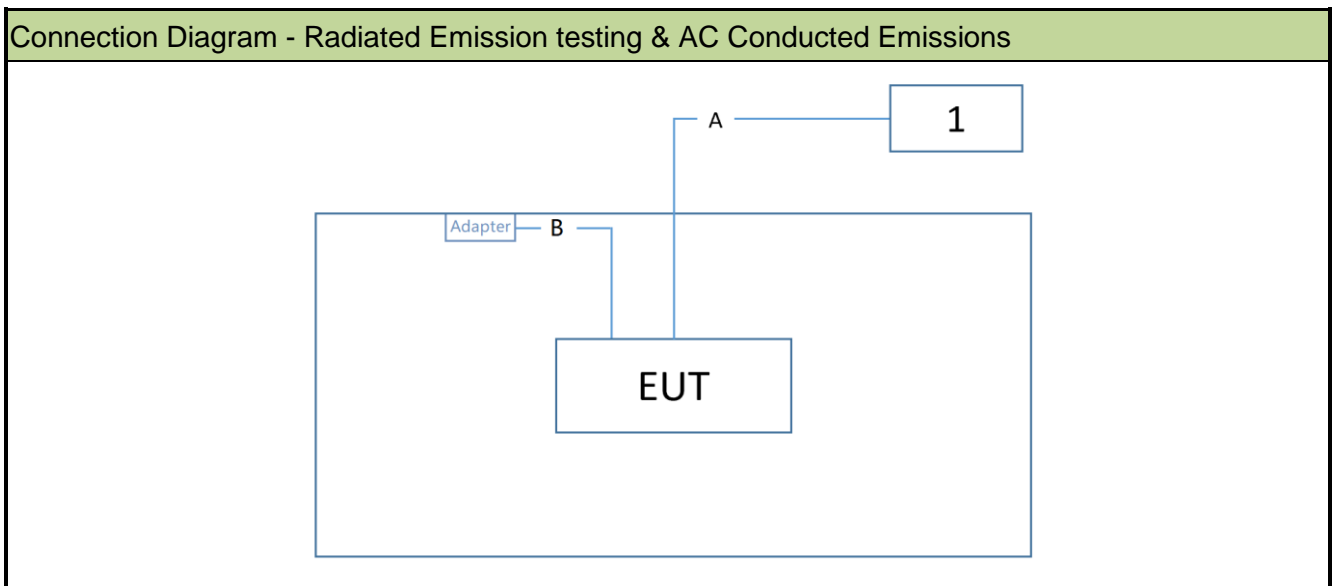

Cable Type		Cable Description
A	LAN Cable	Non shielded, > 10m
B	Power Cable	Non shielded, < 2.0m

Note: We only selected AC/DC Adapter 1# for RF testing.

1.10. Test System Details

Product	Manufacturer	Model No.
1 Notebook	Dell	P62G

1.11. Duty Cycle

5GHz (NII) operation is possible in 20MHz, 40MHz and 80MHz channel bandwidths. The maximum achievable duty cycles for all modes were determined based on measurements performed on a spectrum analyzer in zero-span mode with RBW = 8MHz, VBW = 50MHz. The RBW and VBW were both greater than 50/T, where T is the minimum transmission duration, and the number of sweep points across T was greater than 100. The duty cycles are as follows:

Test Mode	Duty Cycle
802.11a	94.82%
802.11n-HT20	95.49%
802.11n-HT40	90.08%
802.11ac-VHT20	95.07%
802.11ac-VHT40	90.74%
802.11ac-VHT80	84.03%
802.11ax-HE20	92.97%
802.11ax-HE40	89.71%
802.11ax-HE80	82.85%

Duty Cycle (T = Transmission Duration)

802.11a (T = 1.391ms)

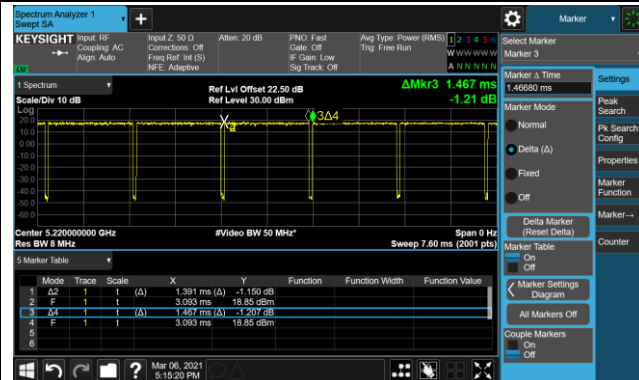

802.11n-HT20 (T = 1.292ms)

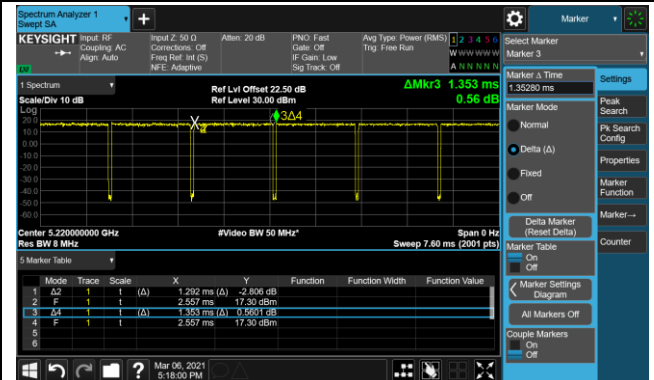

802.11n-HT40 (T = 643.5us)

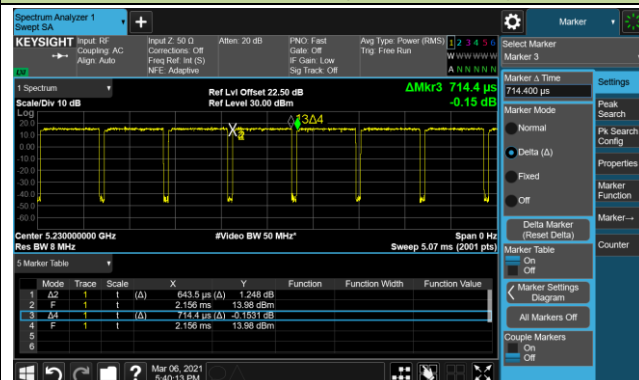

802.11ac-VHT20 (T = 1.311ms)

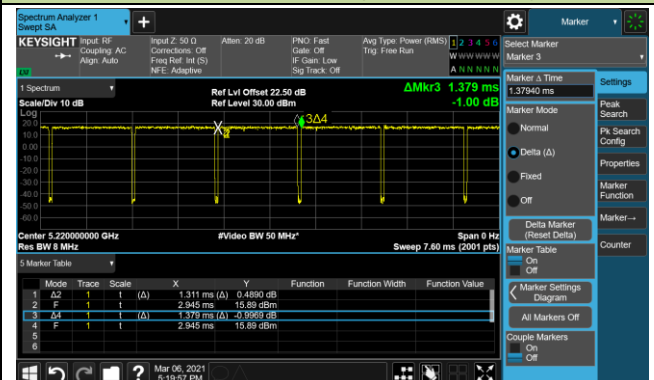

802.11ac-VHT40 (T = 646us)

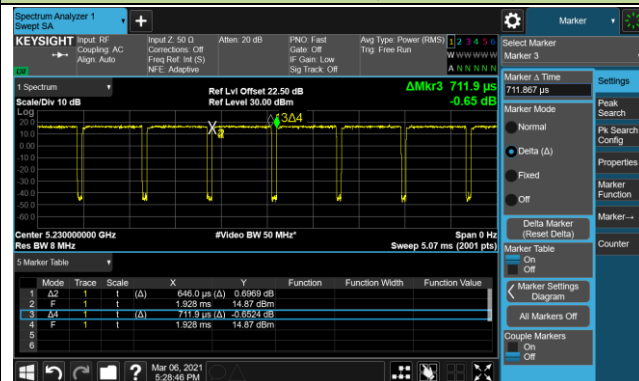

802.11ac-VHT80 (T = 321.0us)

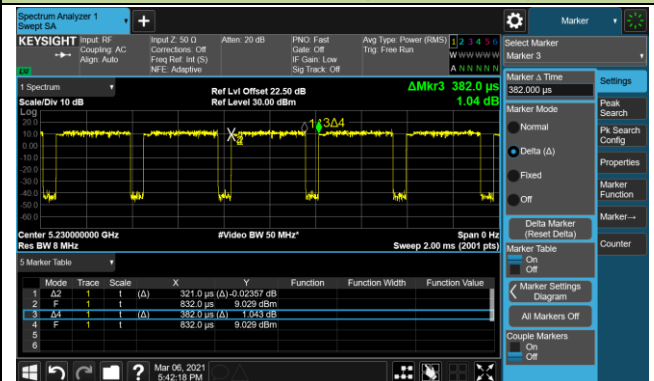

802.11 ax-HE40 (T = 535.1us)

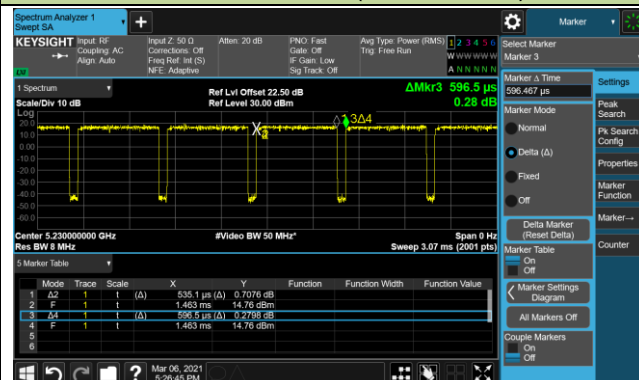

802.11 ax-HE80 (T = 285.0us)

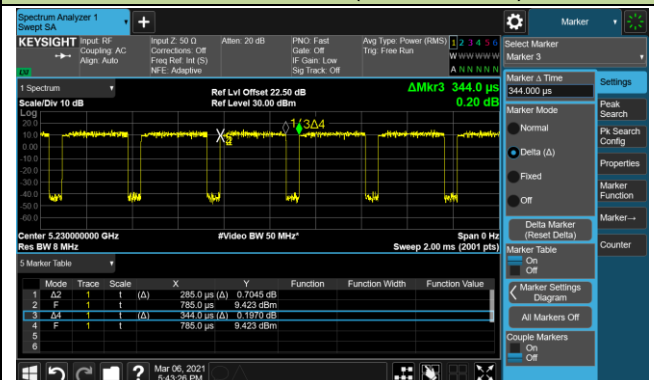

1.12. Description of Test Software

The test utility software used during testing was “QATool_Dbg.exe”, and the version was 0.0.2.33. Power parameter value refers to operation description.

1.13. EMI Suppression Device(s)/Modifications

No EMI suppression device(s) were added and/or no modifications were made during testing.

1.14. Test Environment Condition

Ambient Temp.	15 ~ 35°C
Relative Humidity	20 ~ 75%RH

2. ANTENNA REQUIREMENTS

Excerpt from §15.203 of the FCC Rules/Regulations:

“An intentional radiator antenna shall be designed to ensure that no antenna other than that furnished by the responsible party can be used with the device. The use of a permanently attached antenna or of an antenna that uses a unique coupling to the intentional radiator shall be considered sufficient to comply with the provisions of this section.”

- The antenna of the device is **permanently attached**.
- There are no provisions for connection to an external antenna.

Conclusion:

The unit complies with the requirement of §15.203.

3. TEST EQUIPMENT CALIBRATION DATE

Conducted Emission (WZ-SR2)

Instrument	Manufacturer	Type No.	Asset No.	Cali. Interval	Cali. Due Date
EMI Test Receiver	R&S	ESR3	MRTSUE06185	1 year	2022/01/12
Two-Line V-Network	R&S	ENV216	MRTSUE06002	1 year	2021/09/09
Thermal Hygrometer	testo	608-H1	MRTSUE06404	1 year	2021/07/26
Shielding Room	MIX-BEP	Chamber-SR2	MRTSUE06215	N/A	N/A

Conducted Emission (SIP-SR2)

Instrument	Manufacturer	Type No.	Asset No.	Cali. Interval	Cali. Due Date
EMI Test Receiver	R&S	ESR3	MRTSUE06613	1 year	2021/07/02
Two-Line V-Network	R&S	ENV216	MRTSUE06003	1 year	2021/09/09
Thermal Hygrometer	testo	608-H1	MRTSUE06621	1 year	2021/12/03

Radiated Emission (WZ-AC1)

Instrument	Manufacturer	Type No.	Asset No.	Cali. Interval	Cali. Due Date
EMI Test Receiver	R&S	ESR7	MRTSUE06001	1 year	2022/01/04
PXA Signal Analyzer	Keysight	N9030B	MRTSUE06395	1 year	2021/08/30
Loop Antenna	Schwarzbeck	FMZB 1519	MRTSUE06025	1 year	2021/11/08
Bilog Period Antenna	Schwarzbeck	VULB 9168	MRTSUE06172	1 year	2021/08/08
Horn Antenna	Schwarzbeck	BBHA 9120D	MRTSUE06023	1 year	2021/09/27
Horn Antenna	Schwarzbeck	BBHA9170	MRTSUE06597	1 year	2021/12/14
Horn Antenna	ETS.LINDGEN	3117	MRTSUE06257	1 year	2021/09/27
Microwave System Amplifier	Agilent	83017A	MRTSUE06076	1 year	2021/11/14
Preamplifier	Schwarzbeck	BBV 9721	MRTSUE06121	1 year	2021/06/09
Thermal Hygrometer	testo	608-H1	MRTSUE06403	1 year	2021/07/26
Anechoic Chamber	TDK	Chamber-AC1	MRTSUE06212	1 year	2021/04/28
Anechoic Chamber	TDK	Chamber-AC1	MRTSUE06212	1 year	2022/04/29

Radiated Emission (WZ-AC2)

Instrument	Manufacturer	Type No.	Asset No.	Cali. Interval	Cali. Due Date
MXE EMI Receiver	Keysight	N9038A	MRTSUE06125	1 year	2021/07/02
Loop Antenna	Schwarzbeck	FMZB 1519	MRTSUE06025	1 year	2021/11/08
Bilog Period Antenna	Schwarzbeck	VULB 9162	MRTSUE06022	1 year	2021/05/23
Bilog Period Antenna	Schwarzbeck	VULB 9162	MRTSUE06022	1 year	2022/05/24
Broad-Band Horn Antenna	Schwarzbeck	BBHA 9120D	MRTSUE06171	1 year	2021/10/25
Horn Antenna	Schwarzbeck	BBHA9170	MRTSUE06597	1 year	2021/12/14
Horn Antenna	ETS.LINDGEN	3117	MRTSUE06257	1 year	2021/09/27
Broadband Coaxial Preampfier	Schwarzbeck	BBV 9718	MRTSUE06176	1 year	2021/11/14
Preampfier	Schwarzbeck	BBV 9721	MRTSUE06121	1 year	2021/06/09
Thermal Hygrometer	Minggao	ETH529	MRTSUE06170	1 year	2021/12/08
Anechoic Chamber	RIKEN	Chamber-AC2	MRTSUE06213	1 year	2021/04/28
Anechoic Chamber	RIKEN	Chamber-AC2	MRTSUE06213	1 year	2022/04/29

Radiated Emission (SIP-AC1)

Instrument	Manufacturer	Type No.	Asset No.	Cali. Interval	Cali. Due Date
EMI Test Receiver	R&S	ESR3	MRTSUE06612	1 year	2021/07/02
EXA Signal Analyzer	Keysight	N9010B	MRTSUE06559	1 year	2021/07/23
Loop Antenna	Schwarzbeck	FMZB 1519	MRTSUE06025	1 year	2021/11/08
Bilog Period Antenna	Schwarzbeck	VULB9168	MRTSUE06645	1 year	2021/08/30
Double Ridged Horn Antenna	R&S	HF907	MRTSUE06610	1 year	2021/08/30
Preampfier	EMCI	EMC051845SE	MRTSUE06600	1 year	2021/11/12
Thermal Hygrometer	testo	608-H1	MRTSUE06620	1 year	2021/12/03
Anechoic Chamber	RIKEN	SIP-AC1	MRTSUE06554	1 year	2021/12/24

Radiated Emission (SIP-AC2)

Instrument	Manufacturer	Type No.	Asset No.	Cali. Interval	Cali. Due Date
EMI Test Receiver	R&S	ESR3	MRTSUE06613	1 year	2021/07/02
MXA Signal Analyzer	Keysight	N9020B	MRTSUE06604	1 year	2021/09/26
Loop Antenna	Schwarzbeck	FMZB 1519	MRTSUE06025	1 year	2021/11/08
Bilog Period Antenna	Schwarzbeck	VULB9168	MRTSUE06646	1 year	2021/08/30
Horn Antenna	Schwarzbeck	BBHA9120D	MRTSUE06648	1 year	2021/11/26
Horn Antenna	Schwarzbeck	BBHA9170	MRTSUE06599	1 year	2021/11/26
Preamplifier	EMCI	EMC051845SE	MRTSUE06644	1 year	2021/11/12
Preamplifier	EMCI	EMC184045SE	MRTSUE06602	1 year	2021/10/13
Thermal Hygrometer	testo	608-H1	MRTSUE06624	1 year	2021/12/03
Anechoic Chamber	RIKEN	SIP-AC2	MRTSUE06781	1 year	2021/12/24

Radiated Emission (SIP-AC3)

Instrument	Manufacturer	Type No.	Asset No.	Cali. Interval	Cali. Due Date
EMI Test Receiver	R&S	ESR3	MRTSUE06612	1 year	2021/07/02
EXA Signal Analyzer	Keysight	N9010B	MRTSUE06559	1 year	2021/07/23
Loop Antenna	Schwarzbeck	FMZB 1519	MRTSUE06025	1 year	2021/11/08
Bilog Period Antenna	Schwarzbeck	VULB9168	MRTSUE06647	1 year	2021/08/08
Double Ridged Horn Antenna	R&S	HF907	MRTSUE06611	1 year	2021/09/13
Horn Antenna	Schwarzbeck	BBHA9170	MRTSUE06598	1 year	2021/11/26
Preamplifier	EMCI	EMC012645SE	MRTSUE06642	1 year	2022/01/14
Preamplifier	EMCI	EMC184045SE	MRTSUE06641	1 year	2022/01/14
Thermal Hygrometer	testo	608-H1	MRTSUE06622	1 year	2021/12/03
Anechoic Chamber	RIKEN	SIP-AC3	MRTSUE06782	1 year	2021/12/24

Conducted Test Equipment (WZ-TR3)

Instrument	Manufacturer	Type No.	Asset No.	Cali. Interval	Cali. Due Date
EXA Signal Analyzer	Agilent	N9020A	MRTSUE06106	1 year	2021/04/12
EXA Signal Analyzer	Agilent	N9020A	MRTSUE06106	1 year	2022/04/13
EXA Signal Analyzer	Keysight	N9010B	MRTSUE06607	1 year	2022/01/07
Signal Analyzer	R&S	FSV40	MRTSUE06218	1 year	2021/04/12
Signal Analyzer	R&S	FSV40	MRTSUE06218	1 year	2022/04/13
Power Meter	Agilent	U2021XA	MRTSUE06030	1 year	2021/10/22
USB wideband power sensor	Keysight	U2021XA	MRTSUE06446	1 year	2021/08/30
USB wideband power sensor	Keysight	U2021XA	MRTSUE06447	1 year	2021/08/08
Attenuator	MVE	001	MRTSUE06547	NA	NA
Attenuator	MVE	001	MRTSUE06529	NA	NA
Attenuator	MVE	001	MRTSUE06540	NA	NA
Bluetooth Test Set	Anritsu	MT8852B-042	MRTSUE06389	1 year	2021/06/07
Bluetooth Test Set	Anritsu	MT8852B-042	MRTSUE06389	1 year	2022/06/08
Audio Analyzer	Agilent	U8903B	MRTSUE06143	1 year	2021/05/18
Audio Analyzer	Agilent	U8903B	MRTSUE06143	1 year	2022/05/19
Modulation Analyzer	HP	HP8901A	MRTSUE06098	1 year	2021/09/26
Wideband Radio Communication Tester	R&S	CMW 500	MRTSUE06243	1 year	2021/10/20
DC Power Supply	GWINSTEK	DPS-3303C	MRTSUE06064	N/A	N/A
Temperature & Humidity Chamber	BAOYT	BYH-150CL	MRTSUE06051	1 year	2021/10/22
Thermal Hygrometer	testo	608-H1	MRTSUE06401	1 year	2021/07/26

Conducted Test Equipment (SIP-SR5)

Instrument	Manufacturer	Type No.	Asset No.	Cali. Interval	Cali. Due Date
Signal Analyzer	R&S	FSV40	MRTSUE06218	1 year	2021/04/12
Signal Analyzer	R&S	FSV40	MRTSUE06218	1 year	2022/04/13
PXA Signal Analyzer	Keysight	N9030B	MRTSUE06395	1 year	2021/08/30
USB wideband power sensor	Agilent	U2021XA	MRTSUE06595	1 year	2021/09/26
USB wideband power sensor	Agilent	U2021XA	MRTSUE06596	1 year	2021/09/26
Attenuator	MVE	001	MRTSUE06547	NA	NA
Attenuator	MVE	001	MRTSUE06529	NA	NA
Attenuator	MVE	001	MRTSUE06540	NA	NA
Wideband Radio Communication Tester	R&S	CMW 500	MRTSUE06243	1 year	2021/10/20
Bluetooth Test Set	Anritsu	MT8852B-042	MRTSUE06389	1 year	2021/06/07
Bluetooth Test Set	Anritsu	MT8852B-042	MRTSUE06389	1 year	2022/06/08
Temperature Chamber	BAOYT	BYG-408CS	MRTSUE06847	1 year	2022/02/23
Thermal Hygrometer	testo	622	MRTSUE06629	1 year	2021/11/25

Software	Version	Function
EMI Software	V3	EMI Test Software

4. MEASUREMENT UNCERTAINTY

Where relevant, the following test uncertainty levels have been estimated for tests performed on the EUT as specified in CISPR 16-4-2. This uncertainty represents an expanded uncertainty expressed at approximately the 95% confidence level using a coverage factor of $k = 2$.

AC Conducted Emission Measurement
Measurement Uncertainty for a Level of Confidence of 95% ($U=2Uc(y)$): 9kHz~150kHz: 3.74dB 150kHz~30MHz: 3.44dB
Radiated Disturbance
Measurement Uncertainty for a Level of Confidence of 95% ($U=2Uc(y)$): Horizontal: 30MHz~300MHz: 5.04dB 300MHz~1GHz: 4.95dB 1GHz~40GHz: 6.40dB Vertical: 30MHz~300MHz: 5.24dB 300MHz~1GHz: 6.03dB 1GHz~40GHz: 6.40dB
Spurious Emissions, Conducted
Measuring Uncertainty for a Level of Confidence of 95% ($U=2Uc(y)$): 0.78dB
Output Power
Measuring Uncertainty for a Level of Confidence of 95% ($U=2Uc(y)$): 1.13dB
Power Spectrum Density
Measuring Uncertainty for a Level of Confidence of 95% ($U=2Uc(y)$): 1.15dB
Occupied Bandwidth
Measuring Uncertainty for a Level of Confidence of 95% ($U=2Uc(y)$): 0.28%

5. TEST RESULT

5.1. Summary

FCC Section(s)	Test Description	Test Limit	Test Condition	Test Result	Reference
15.407(a)	26dB Bandwidth	N/A	Conducted	Pass	Section 5.2
15.407(e)	6dB Bandwidth	$\geq 500\text{kHz}$		Pass	Section 5.3
15.407(a)(1)(ii), (2), (3)	Maximum Output Power	< 1 Watt for UNII-1 & UNII-3 < 250mW for UNII-2		Pass	Section 5.4
15.407(h)(1)	Transmit Power Control	< 24 dBm		N/A	Section 5.5
15.407(a)(1)(ii), (2), (3), (5)	Power Spectral Density	< 17dBm/MHz for UNII-1 < 11dBm/MHz for UNII-2 < 30dBm/500kHz for UNII-3		Pass	Section 5.6
15.407(b)(1), (2), (3), (4)(i)	Undesirable Emissions	Refer to Section 6.7	Radiated	Pass	Section 5.7, 5.8
15.205, 15.209 15.407(b)(7), (8), (9)	General Field Strength Limits (Restricted Bands and Radiated Emission Limits)	Emissions in restricted bands must meet the radiated limits detailed in 15.209		Pass	
15.207	AC Conducted Emissions 150kHz - 30MHz	< FCC 15.207 limits	Line Conducted	Pass	Section 5.9

Notes:

- 1) The analyzer plots shown in this section were all taken with a correction table loaded into the analyzer. The correction table was used to account for the losses of the cables and attenuators used as part of the system to connect the EUT to the analyzer at all frequencies of interest.
- 2) Output power test was verified over all data rates of each mode (data refers to operational description), and then choose the maximum power output (low data rate) for final test of each channel.
- 3) Test Items "26dB Bandwidth" & "6dB Bandwidth" showed the worst test data in this report.
- 4) EUT supports one configuration only in 802.11ax full RU mode, i.e. 242 tone in 11ax-HE20 and 484 tone in 11ax-HE40.

5.2. 26dB Bandwidth Measurement

5.2.1. Test Limit

N/A

5.2.2. Test Procedure Used

KDB 789033 D02v02r01 -Section C.1

5.2.3. Test Setting

1. The analyzers' automatic bandwidth measurement capability was used to perform the 26dB bandwidth measurement. The "X" dB bandwidth parameter was set to $X = 26$. The automatic bandwidth measurement function also has the capability of simultaneously measuring the 99% occupied bandwidth. The bandwidth measurement was not influenced by any intermediated power nulls in the fundamental emission.
2. RBW = approximately 1% of the emission bandwidth.
3. VBW $\geq 3 \times$ RBW.
4. Detector = Peak.
5. Trace mode = max hold.

5.2.4. Test Setup

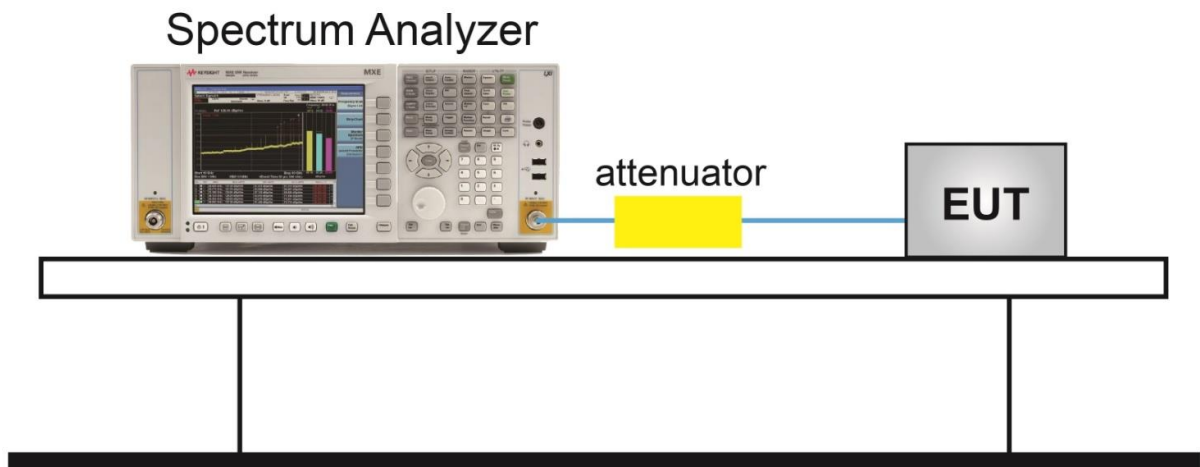

5.2.5. Test Result

Product	WiFi 6 Extender	Test Engineer	Amy Zhang
Test Site	WZ-TR3	Test Date	2021/04/21

Test Mode	Data Rate/ MCS	Channel No.	Frequency (MHz)	26dB Bandwidth (MHz)
802.11a	6Mbps	36	5180	20.13
802.11a	6Mbps	44	5220	25.86
802.11a	6Mbps	48	5240	26.94
802.11a	6Mbps	52	5260	19.91
802.11a	6Mbps	60	5300	19.89
802.11a	6Mbps	64	5320	19.95
802.11a	6Mbps	100	5500	19.73
802.11a	6Mbps	116	5580	19.72
802.11a	6Mbps	140	5700	19.75
802.11a	6Mbps	144	5720	19.88
802.11a	6Mbps	149	5745	29.33
802.11a	6Mbps	157	5785	28.76
802.11a	6Mbps	165	5825	28.63
802.11ac-VHT20	MCS0	36	5180	20.35
802.11ac-VHT20	MCS0	44	5220	20.51
802.11ac-VHT20	MCS0	48	5240	20.52
802.11ac-VHT20	MCS0	52	5260	20.25
802.11ac-VHT20	MCS0	60	5300	20.26
802.11ac-VHT20	MCS0	64	5320	20.41
802.11ac-VHT20	MCS0	100	5500	20.22
802.11ac-VHT20	MCS0	116	5580	20.29
802.11ac-VHT20	MCS0	140	5700	20.34
802.11ac-VHT20	MCS0	144	5720	20.07
802.11ac-VHT20	MCS0	149	5745	26.35
802.11ac-VHT20	MCS0	157	5785	26.79
802.11ac-VHT20	MCS0	165	5825	25.36

Test Mode	Data Rate/ MCS	Channel No.	Frequency (MHz)	26dB Bandwidth (MHz)
802.11ac-VHT40	MCS0	38	5190	40.65
802.11ac-VHT40	MCS0	46	5230	49.53
802.11ac-VHT40	MCS0	54	5270	40.29
802.11ac-VHT40	MCS0	62	5310	40.02
802.11ac-VHT40	MCS0	102	5510	40.21
802.11ac-VHT40	MCS0	110	5550	40.65
802.11ac-VHT40	MCS0	134	5670	40.11
802.11ac-VHT40	MCS0	142	5710	40.02
802.11ac-VHT40	MCS0	151	5755	40.41
802.11ac-VHT40	MCS0	159	5795	40.70
802.11ac-VHT80	MCS0	42	5210	79.61
802.11ac-VHT80	MCS0	58	5290	79.57
802.11ac-VHT80	MCS0	106	5530	79.38
802.11ac-VHT80	MCS0	122	5610	79.69
802.11ac-VHT80	MCS0	138	5690	79.58
802.11ac-VHT80	MCS0	155	5775	79.23

Test Mode	Data Rate/ MCS	Channel No.	Frequency (MHz)	26dB Bandwidth (MHz)
802.11ax-HE20	MCS0	36	5180	23.03
802.11ax-HE20	MCS0	44	5220	29.17
802.11ax-HE20	MCS0	48	5240	28.11
802.11ax-HE20	MCS0	52	5260	23.14
802.11ax-HE20	MCS0	60	5300	23.02
802.11ax-HE20	MCS0	64	5320	23.04
802.11ax-HE20	MCS0	100	5500	23.91
802.11ax-HE20	MCS0	116	5580	22.10
802.11ax-HE20	MCS0	140	5700	26.67
802.11ax-HE20	MCS0	144	5720	23.22
802.11ax-HE20	MCS0	149	5745	29.28
802.11ax-HE20	MCS0	157	5785	28.65
802.11ax-HE20	MCS0	165	5825	28.25
802.11ax-HE40	MCS0	38	5190	39.67
802.11ax-HE40	MCS0	46	5230	60.55
802.11ax-HE40	MCS0	54	5270	39.29
802.11ax-HE40	MCS0	62	5310	39.36
802.11ax-HE40	MCS0	102	5510	39.30
802.11ax-HE40	MCS0	110	5550	39.50
802.11ax-HE40	MCS0	142	5710	39.41
802.11ax-HE40	MCS0	151	5755	39.62
802.11ax-HE40	MCS0	159	5795	39.45
802.11ax-HE80	MCS0	5210	5210	80.17
802.11ax-HE80	MCS0	5290	5290	79.74
802.11ax-HE80	MCS0	5530	5530	79.78
802.11ax-HE80	MCS0	5610	5610	79.68
802.11ax-HE80	MCS0	5690	5690	79.79
802.11ax-HE80	MCS0	5775	5775	79.82

802.11a 26dB Bandwidth

Channel 36 (5180MHz)

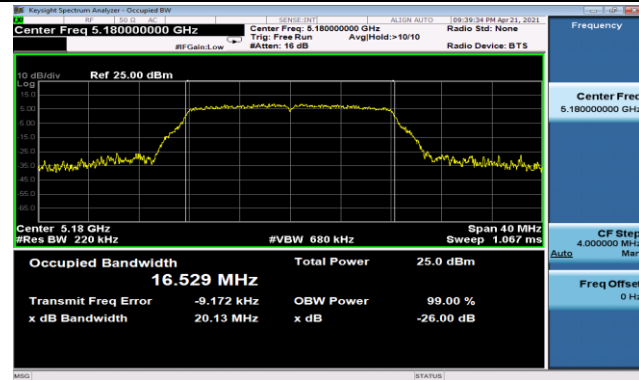

Channel 44 (5220MHz)

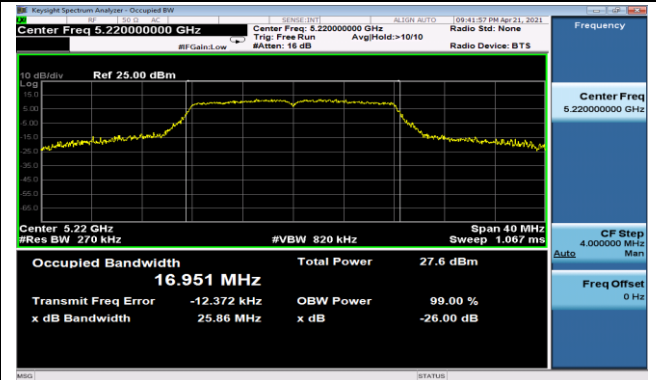

Channel 48 (5240MHz)

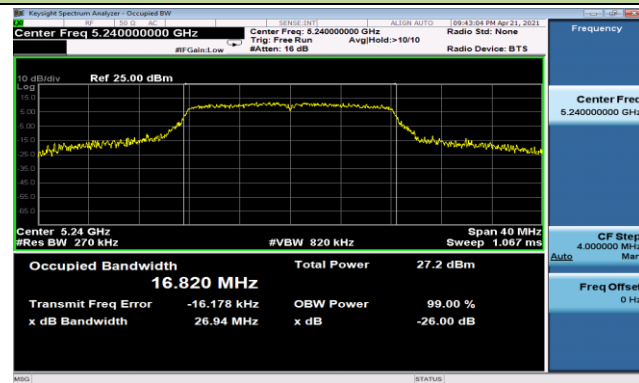

Channel 52 (5260MHz)

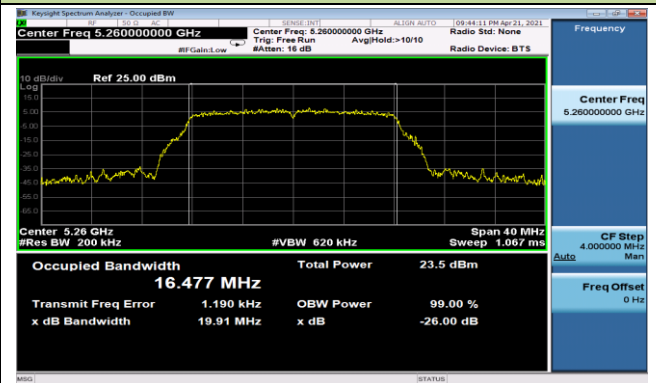

Channel 60 (5300MHz)

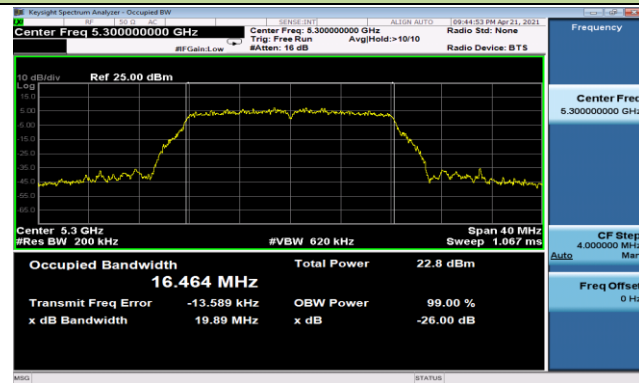

Channel 64 (5320MHz)

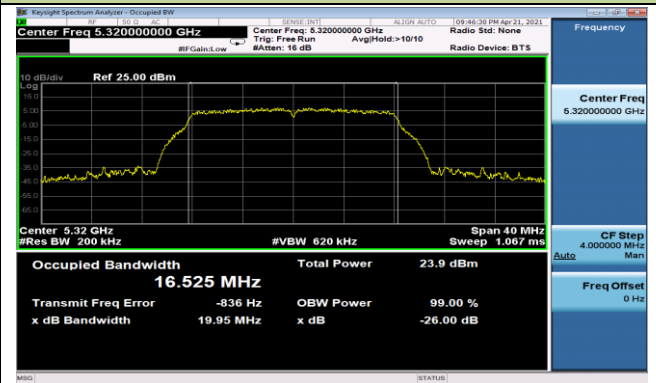

802.11a 26dB Bandwidth

Channel 100 (5500MHz)

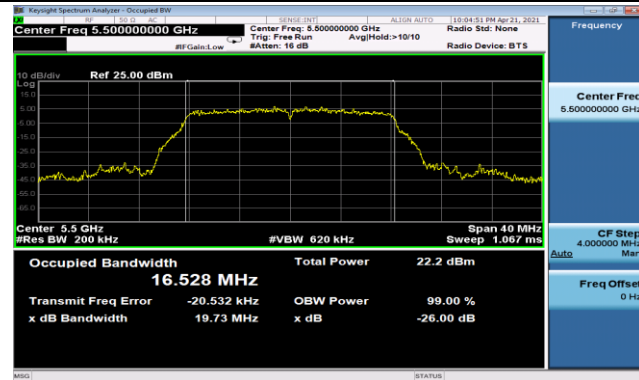

Channel 116 (5580MHz)

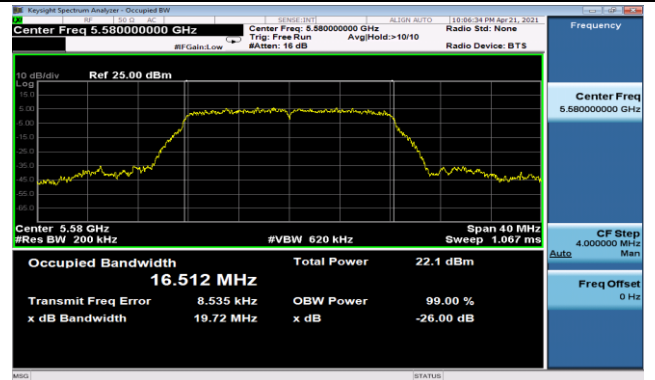

Channel 140 (5700MHz)

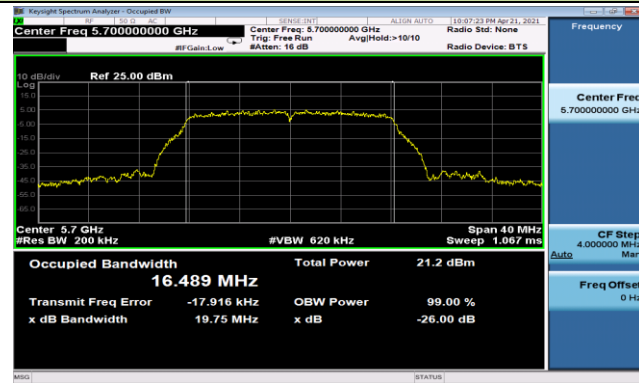

Channel 144 (5720MHz)

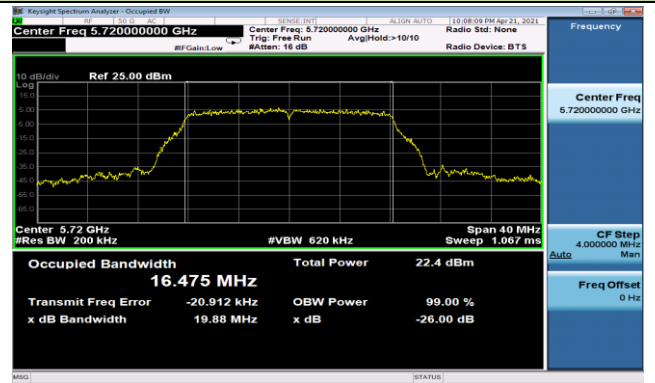

Channel 149 (5745MHz)

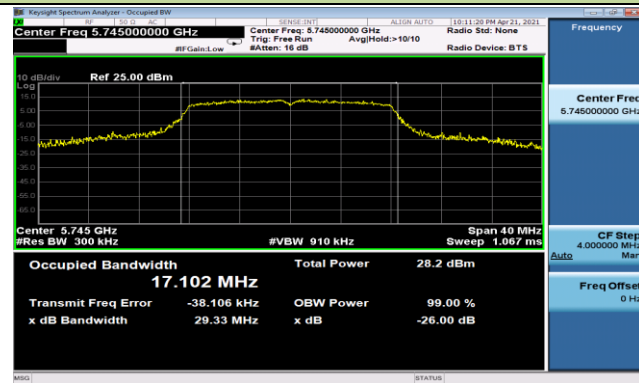

Channel 157 (5785MHz)

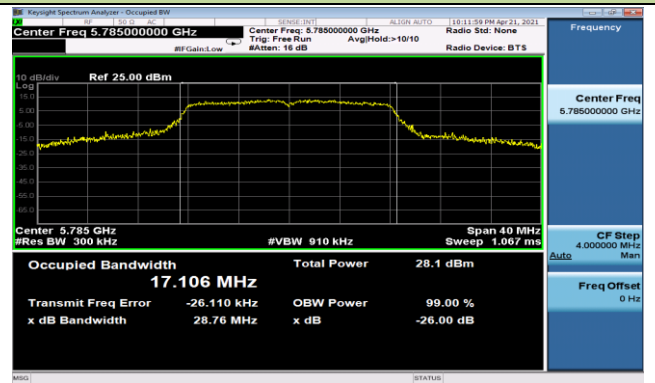

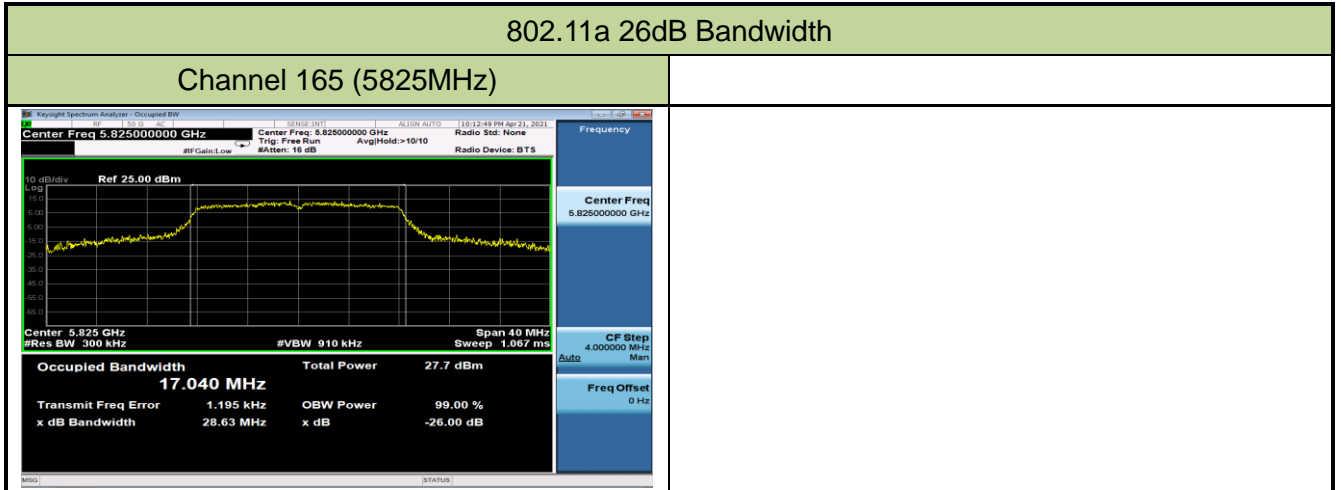

802.11ac-VHT20 26dB Bandwidth

Channel 36 (5180MHz)

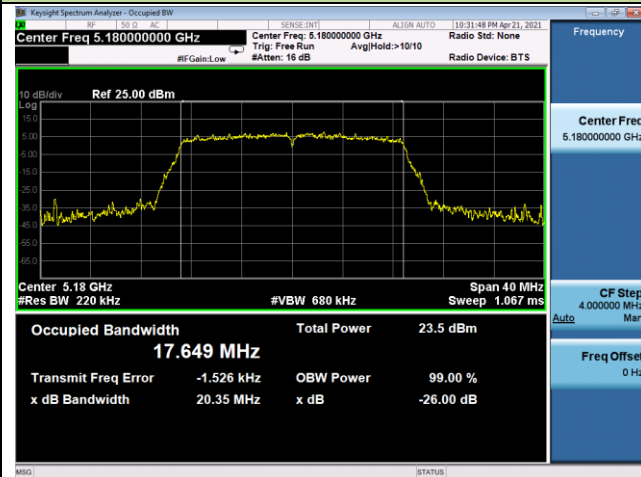

Channel 44 (5220MHz)

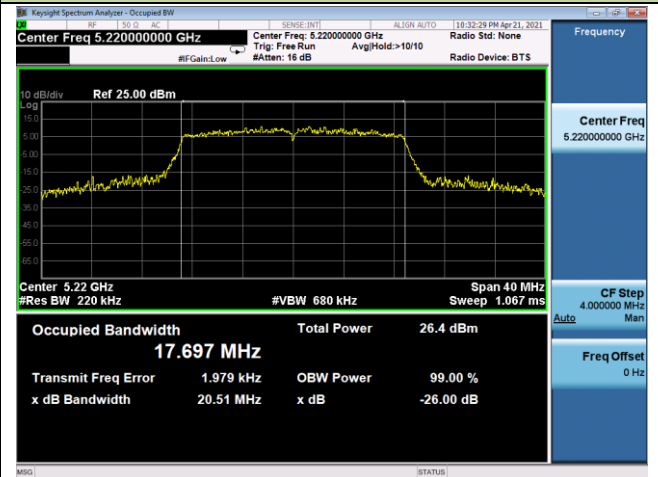

Channel 48 (5240MHz)

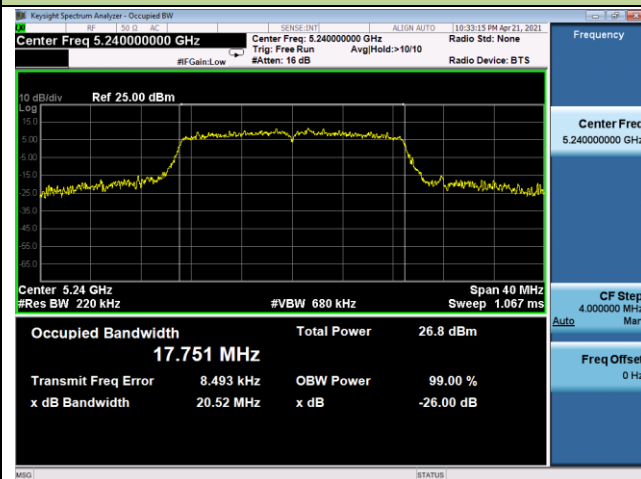

Channel 52 (5260MHz)

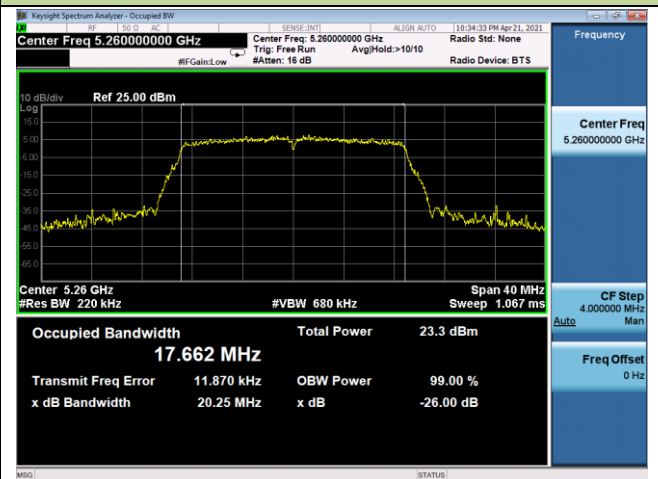

Channel 60 (5300MHz)

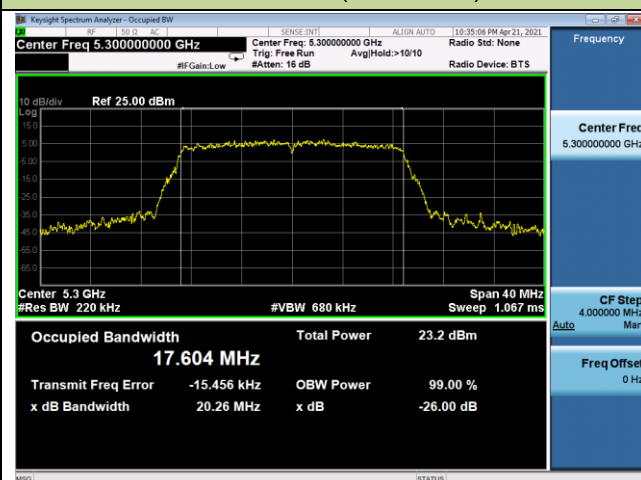

Channel 64 (5320MHz)

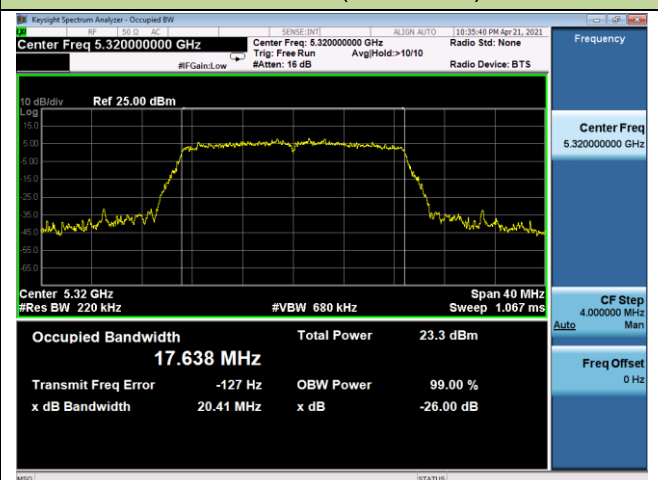

802.11ac-VHT20 26dB Bandwidth

Channel 100 (5500MHz)

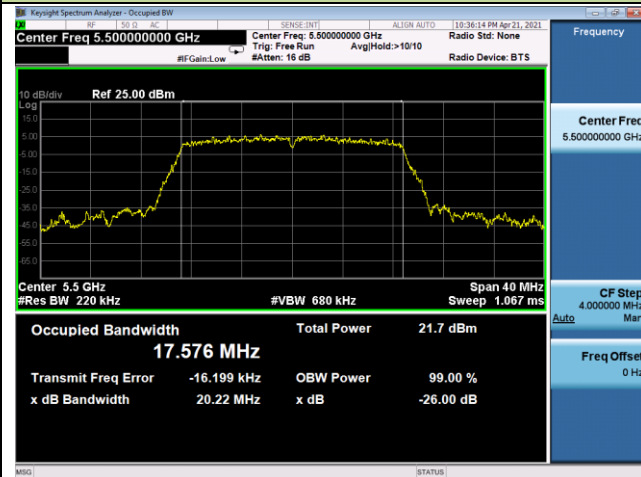

Channel 116 (5580MHz)

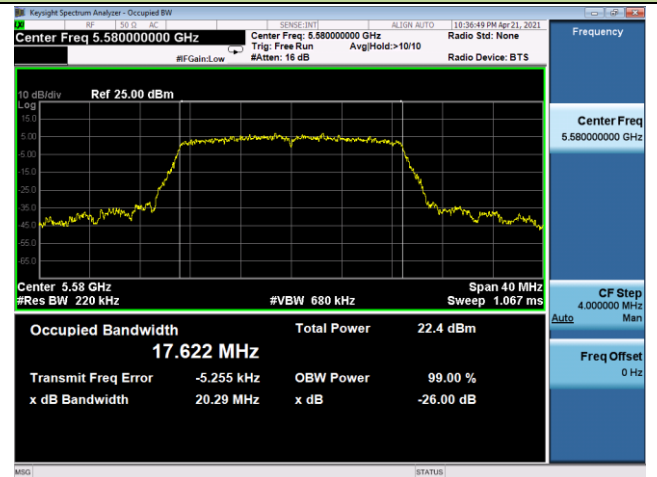

Channel 140 (5700MHz)



Channel 144 (5720MHz)

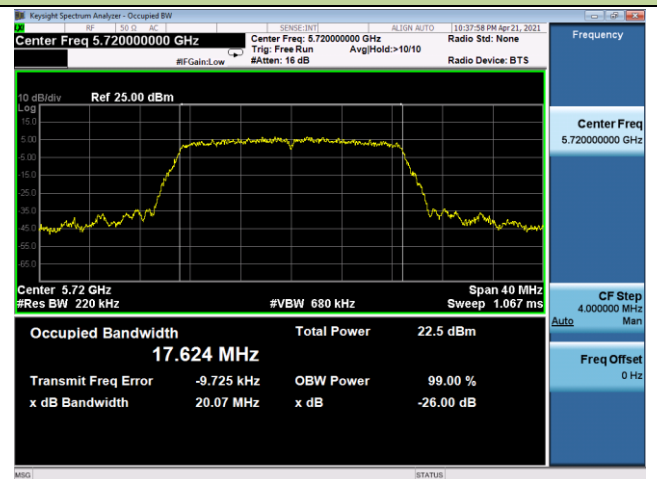

Channel 149 (5745MHz)

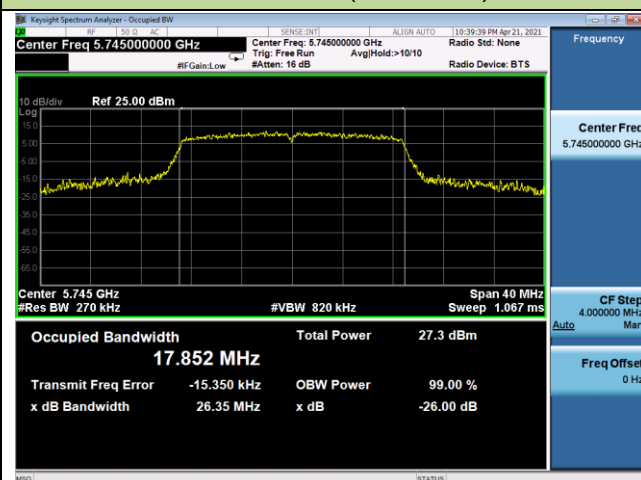

Channel 157 (5785MHz)

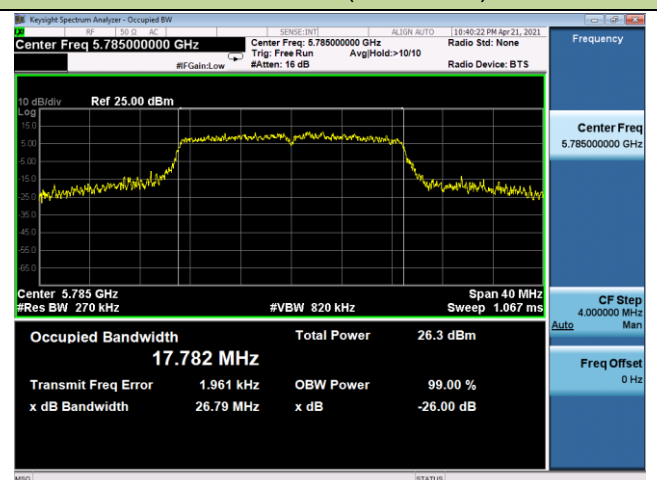

802.11ac-VHT20 26dB Bandwidth

Channel 165 (5825MHz)



802.11ac-VHT40 26dB Bandwidth

Channel 38 (5190MHz)

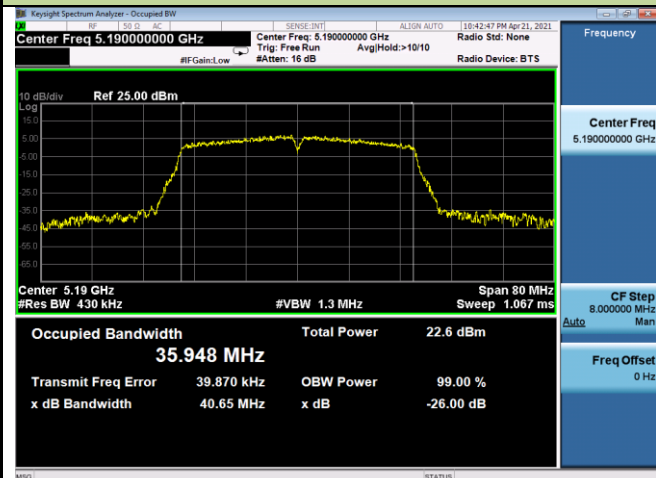

Channel 46 (5230MHz)

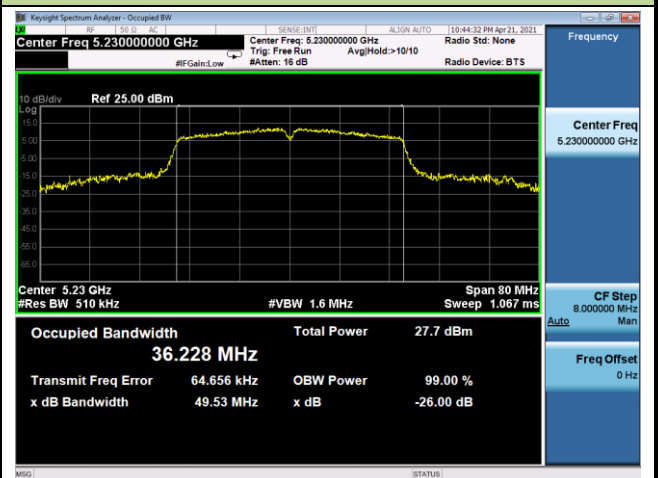

Channel 54 (5270MHz)

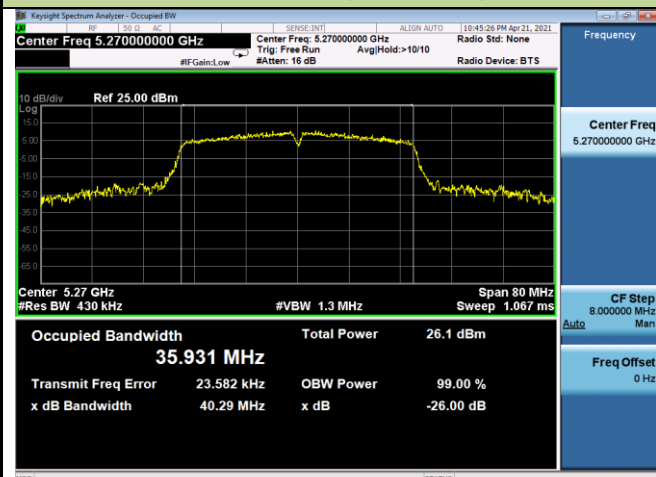

Channel 62 (5310MHz)

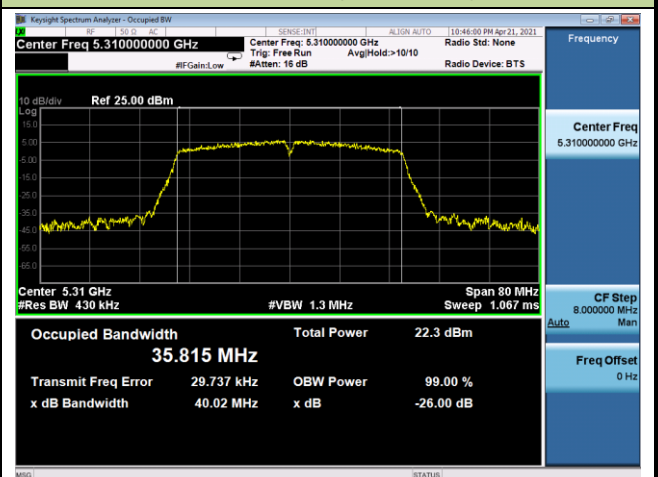

Channel 102 (5510MHz)

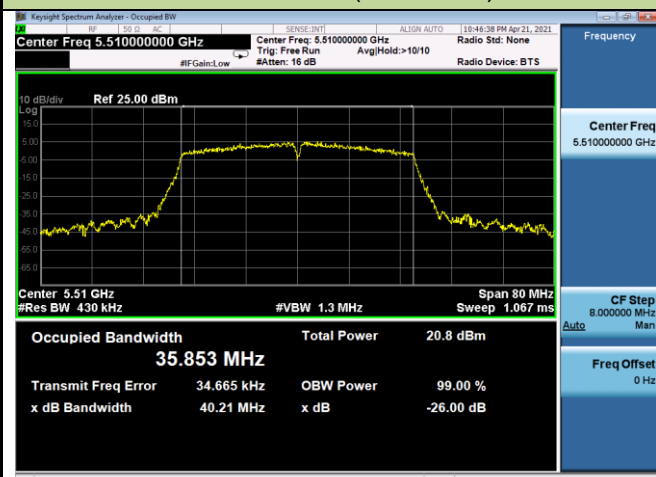

Channel 110 (5550MHz)

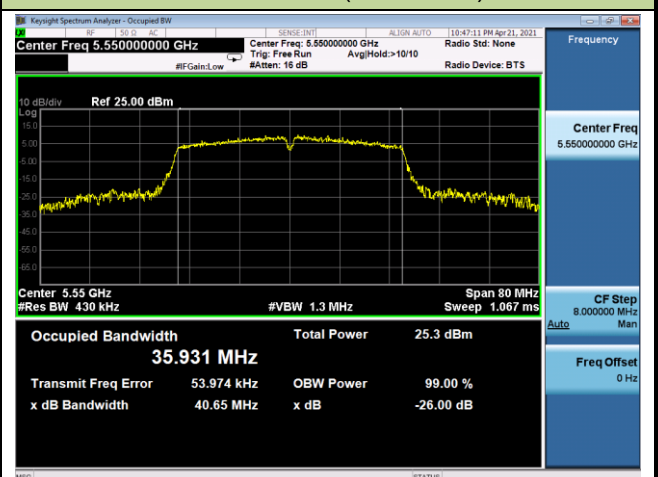

802.11ac-VHT40 26dB Bandwidth

Channel 134 (5670MHz)

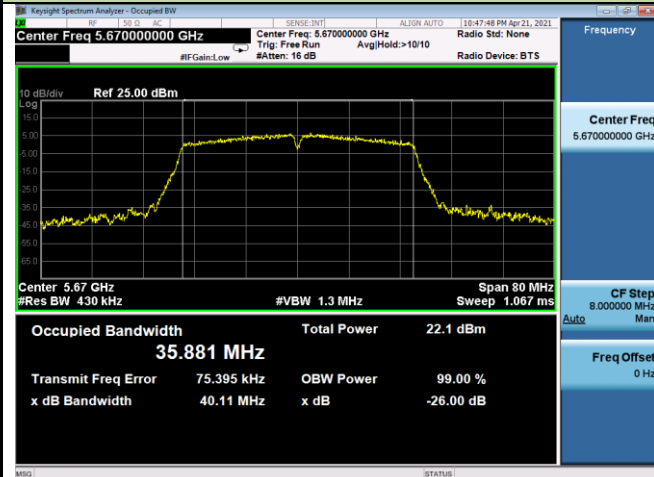

Channel 142 (5710MHz)

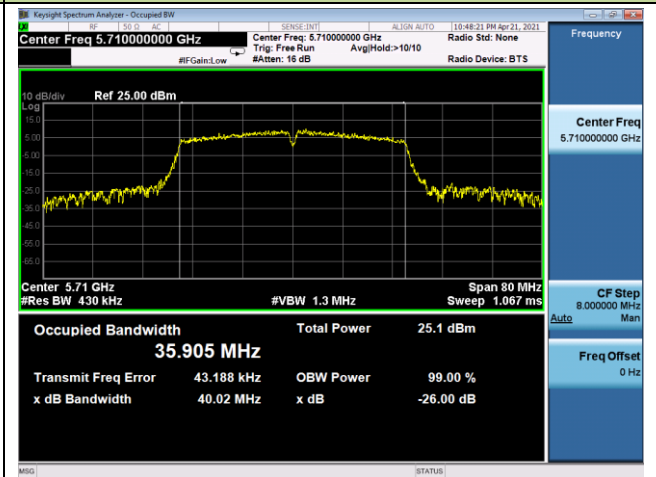

Channel 151 (5755MHz)

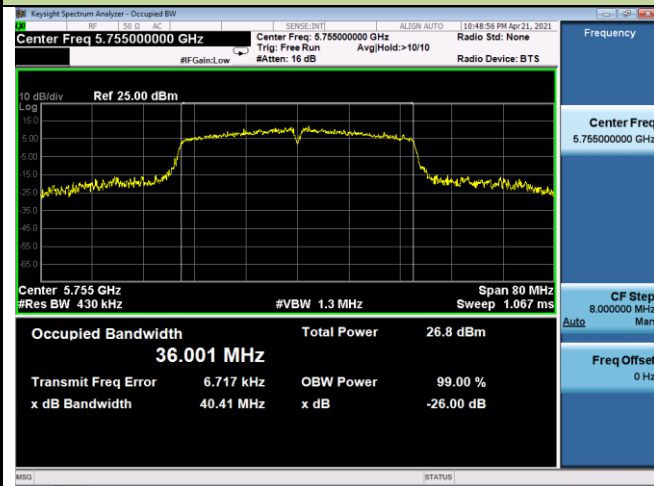

Channel 159 (5795MHz)

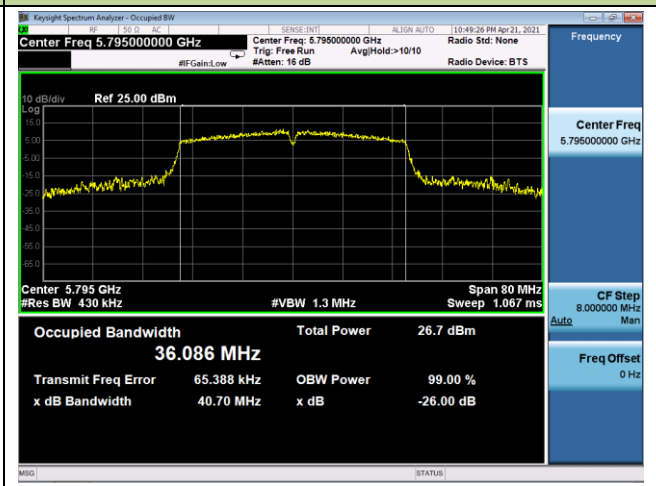

802.11ac-VHT80 26dB Bandwidth

Channel 42 (5210MHz)

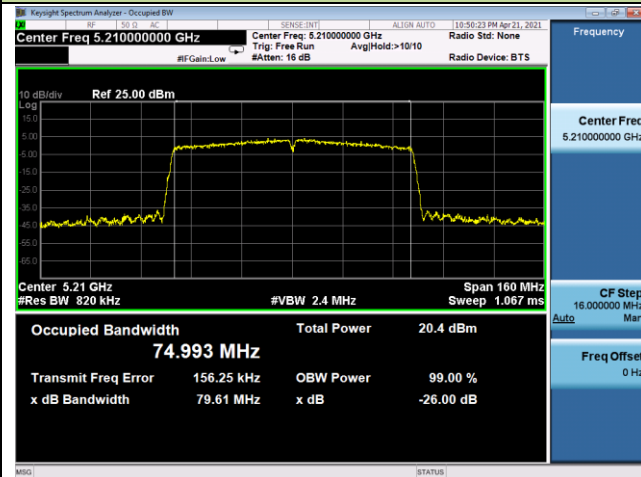

Channel 58 (5290MHz)

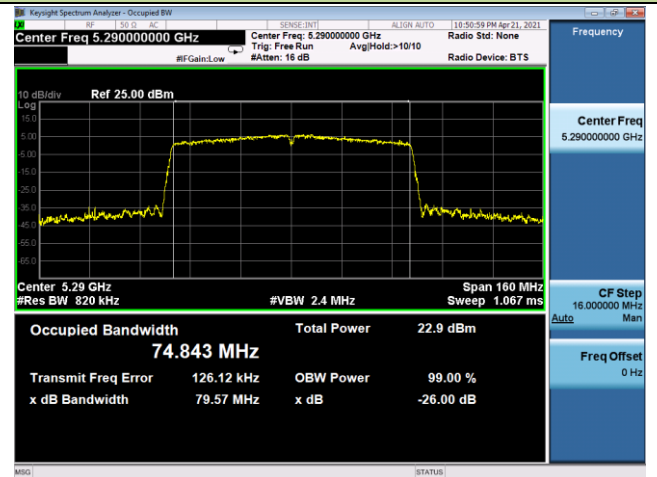

Channel 106 (5530MHz)

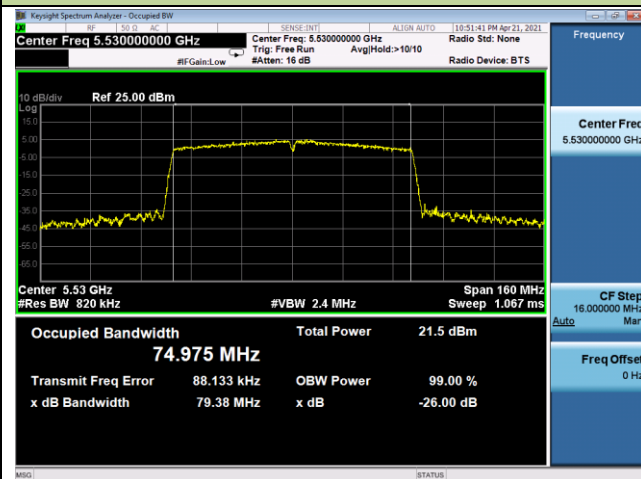

Channel 122 (5610MHz)

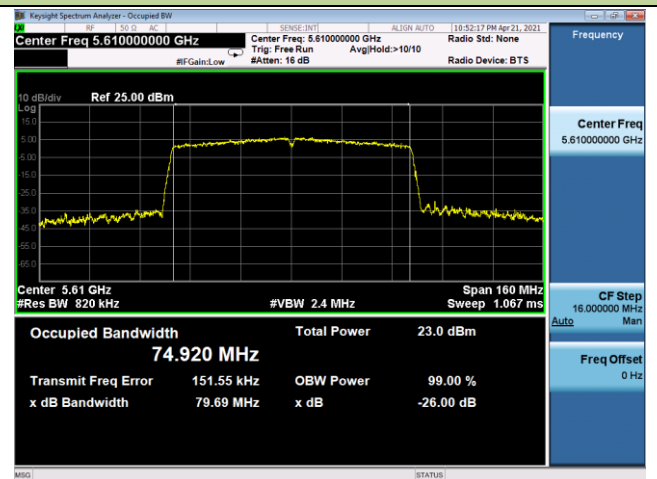

Channel 138(5690MHz)

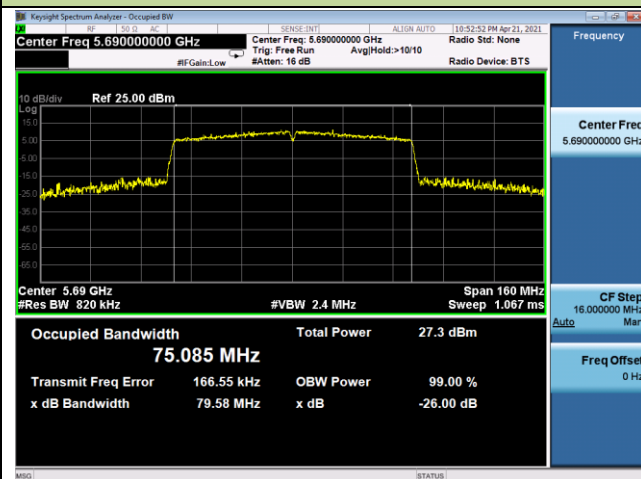

Channel 155 (5775MHz)

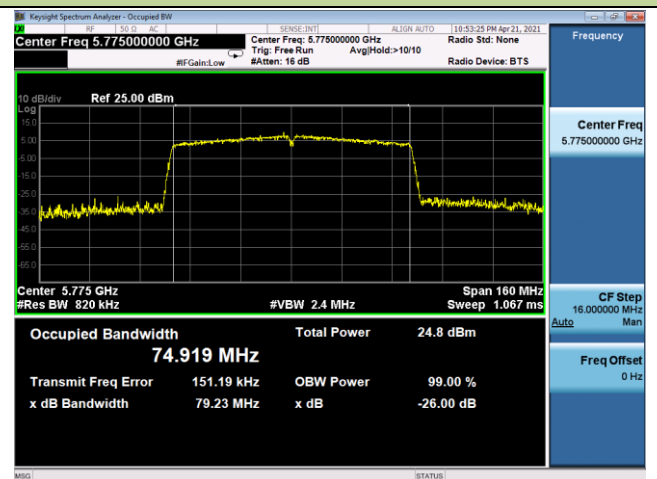

802.11ax-HE20 26dB Bandwidth

Channel 36 (5180MHz)

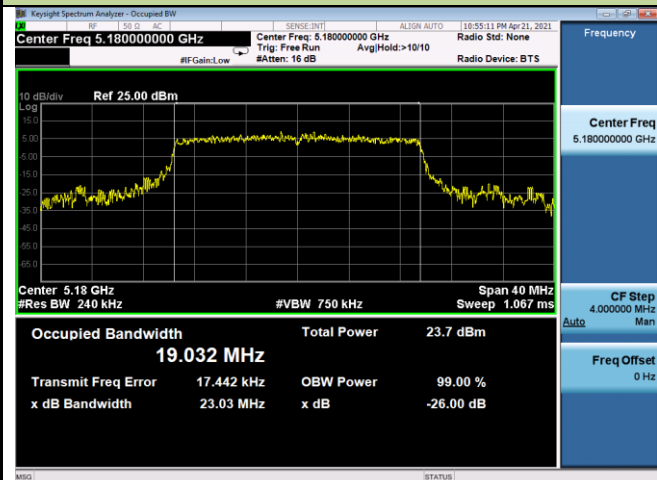

Channel 44 (5220MHz)

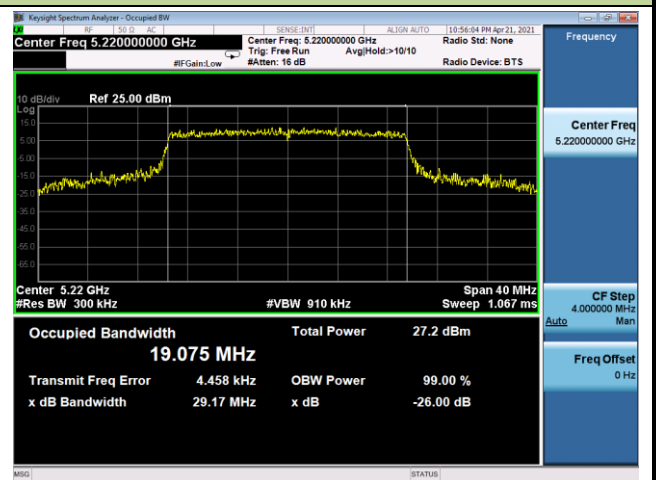

Channel 48 (5240MHz)

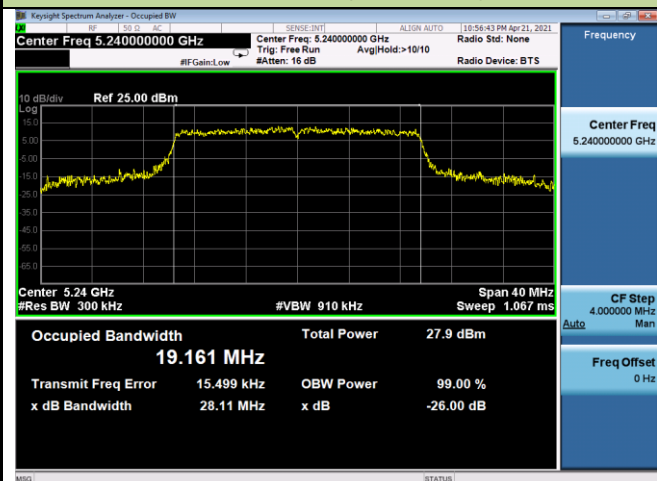

Channel 52 (5260MHz)

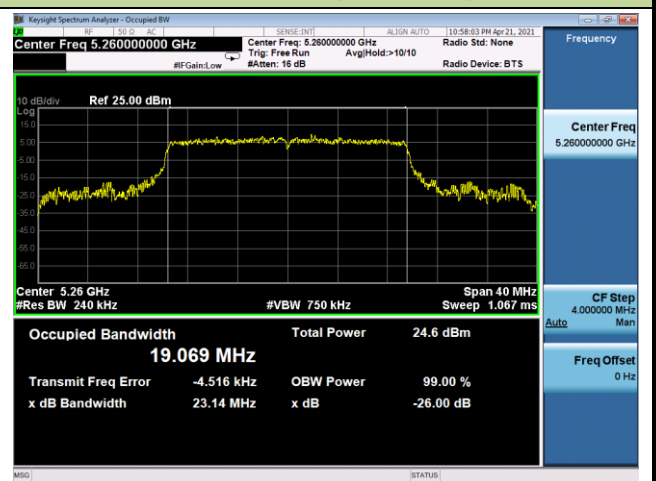

Channel 60 (5300MHz)

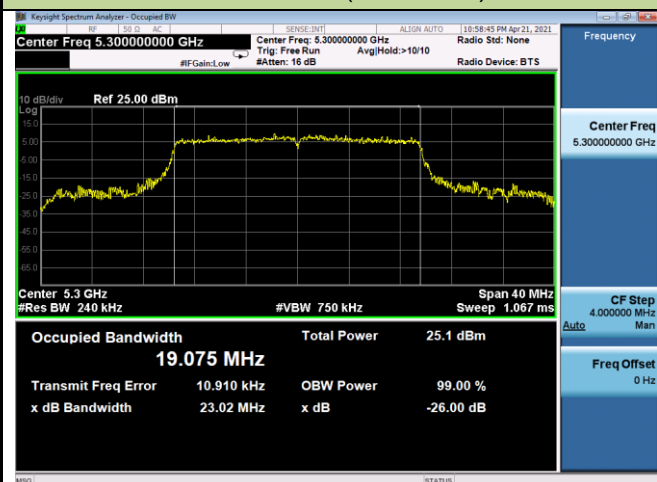

Channel 64 (5320MHz)

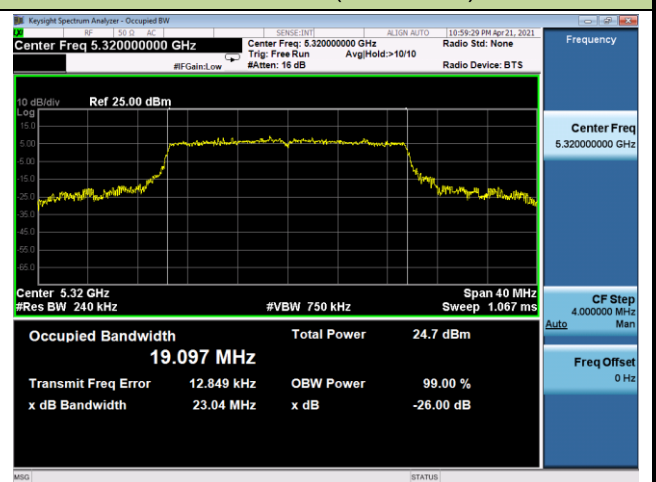

802.11ax-HE20 26dB Bandwidth

Channel 100 (5500MHz)

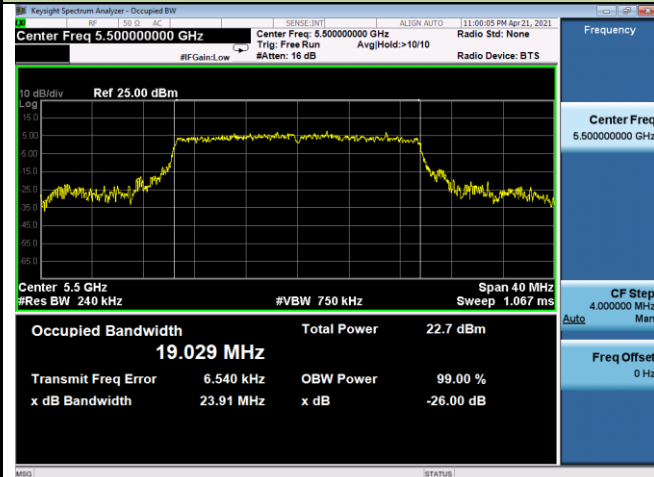

Channel 116 (5580MHz)

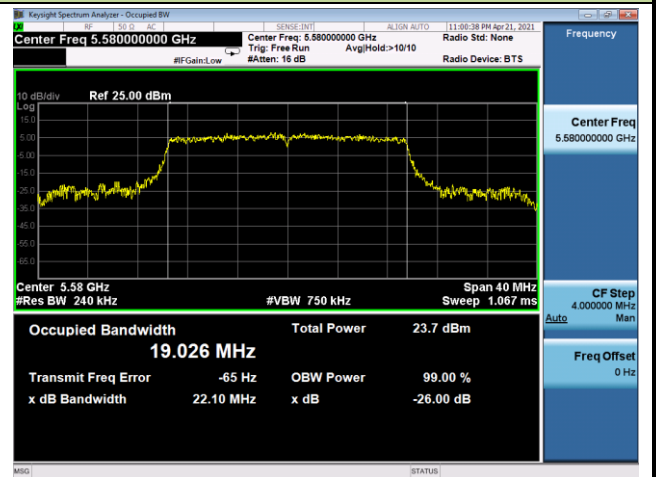

Channel 140 (5700MHz)

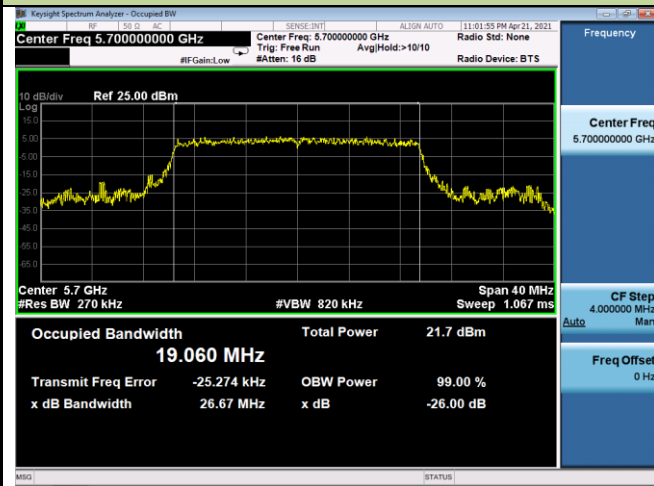

Channel 144 (5720MHz)

