



FCC Part 15.407

TEST REPORT

For

Actiontec Electronics Inc.

3301 Olcott St. Santa Clara, CA 95054

Report Type	Original Report
FCC ID:	FCC ID: LNQT3280
Product Name:	WiFi 6 Gateway Router with Bonded VDSL
Model Name:	T3280
Report Number :	RLK200729001-00D
Report Date :	2020/11/11
Reviewed By :	Zeus Chen <i>Zeus Chen</i>
Prepared By:	
Bay Area Compliance Laboratories Corp.(Linkou Laboratory)	
No. 6, Wende 2Rd., Guishan Dist., Taoyuan City 33382, Taiwan (R.O.C.)	
Tel: +886 (3)3961072; Fax: +886 (3) 3961027	
www.bacl.com.tw	

Note: This test report is prepared for the customer shown above and for the device described herein. It may not be duplicated or used in part without prior written consent from Bay Area Compliance Laboratories Corp. (Linkou Laboratory)

Revision History

Revision	Report Number	Issue Date	Description
1.0	RLK200729001-00D	2020/11/11	Original Report

TABLE OF CONTENTS

1 GENERAL INFORMATION 5

1.1 PRODUCT DESCRIPTION FOR EQUIPMENT UNDER TEST (EUT) 5

1.2 OPERATION CONDITION OF EUT 6

1.3 OBJECTIVE..... 6

1.4 MEASUREMENT UNCERTAINTY 6

1.5 ENVIRONMENTAL CONDITIONS AND TEST DATE..... 7

1.6 TEST FACILITY 7

2 SYSTEM TEST CONFIGURATION..... 8

2.1 DESCRIPTION OF TEST CONFIGURATION 8

2.2 SUPPORT EQUIPMENT AND EXTERNAL CABLE LIST 10

2.3 BLOCK DIAGRAM OF TEST SETUP 10

2.4 DUTY CYCLE 11

3 SUMMARY OF TEST RESULTS13

4 FCC §1.1310, §2.1091, §15.407(F) - MAXIMUM PERMISSIBLE EXPOSURE (MPE)14

4.1 APPLICABLE STANDARD..... 14

4.2 RF EXPOSURE EVALUATION RESULT 15

5 FCC §15.203 – ANTENNA REQUIREMENTS.....16

5.1 APPLICABLE STANDARD..... 16

5.2 ANTENNA LIST AND DETAILS 16

6 FCC §15.207 - AC LINE CONDUCTED EMISSIONS17

6.1 APPLICABLE STANDARD..... 17

6.2 EUT SETUP AND TEST PROCEDURE 17

6.3 TEST EQUIPMENT LIST AND DETAILS..... 18

6.4 TEST DATA AND TEST PLOT..... 18

7 FCC §15.209, §15.205 & §15.407(B) – UNWANTED EMISSION19

7.1 APPLICABLE STANDARD..... 19

7.2 EUT SETUP AND TEST PROCEDURE 21

7.3 TEST EQUIPMENT LIST AND DETAILS..... 22

7.4 TEST DATA AND TEST PLOT..... 23

8 FCC §15.407(A)(E) –EMISSION BANDWIDTH AND OCCUPIED BANDWIDTH33

8.1 APPLICABLE STANDARD..... 33

8.2 TEST PROCEDURE 33

8.3 TEST EQUIPMENT LIST AND DETAILS..... 34

8.4 TEST DATA AND TEST PLOT..... 35

9 FCC §15.407(A)(1) – MAXIMUM OUTPUT POWER53

9.1 APPLICABLE STANDARD..... 53

9.2 TEST PROCEDURE 53

9.3 TEST EQUIPMENT LIST AND DETAILS..... 54

9.4 TEST DATA 54

10 FCC §15.407(A) – POWER SPECTRAL DENSITY57

10.1 APPLICABLE STANDARD..... 57

10.2 TEST PROCEDURE 57

10.3 TEST EQUIPMENT LIST AND DETAILS..... 57

10.4 TEST DATA AND TEST PLOT..... 58

1 General Information

1.1 Product Description for Equipment under Test (EUT)

Applicant	Actiontec Electronics Inc. 3301 Olcott St. Santa Clara, CA 95054
Manufacturer	Actiontec Electronics Inc. 3301 Olcott St. Santa Clara, CA 95054
Product (Equipment)	WiFi 6 Gateway Router with Bonded VDSL
Model Name	T3280
Frequency Range	UNII-2a: 5250 MHz - 5350 MHz ; UNII-2c: 5470 MHz - 5725 MHz
Number of Channels	<p>For UNII-2a: IEEE 802.11a/n HT20/ac VHT20/ax HE20: 4 Channels IEEE 802.11n HT40/ac VHT40/ax HE40: 3 Channels IEEE 802.11ac VHT80/ax HE80: 1 Channels</p> <p>For UNII-2c: IEEE 802.11a/n HT20/ac VHT20/ax HE20: 12 Channels IEEE 802.11n HT40/ac VHT40/ax HE40: 11 Channels IEEE 802.11ac VHT80/ax HE80: 9 Channels</p>
Output Power	<p>For UNII-2a: IEEE 802.11a Mode: 19.65 dBm (0.0923 W) IEEE 802.11n HT20 Mode: 19.83 dBm (0.0962 W) IEEE 802.11n HT40 Mode: 22.52 dBm (0.1786 W) IEEE 802.11ac VHT20 Mode: 20.00 dBm (0.1000 W) IEEE 802.11ac VHT40 Mode: 22.68 dBm (0.1854 W) IEEE 802.11ac VHT80 Mode: 21.44 dBm (0.1393 W) IEEE 802.11ax HE20 Mode: 20.21 dBm (0.1050 W) IEEE 802.11ax HE40 Mode: 22.87 dBm (0.1936 W) IEEE 802.11ax HE80 Mode: 21.60 dBm (0.1445 W)</p> <p>For UNII-2c: IEEE 802.11a Mode: 16.83 dBm (0.0482 W) IEEE 802.11n HT20 Mode: 16.89 dBm (0.0489 W) IEEE 802.11n HT40 Mode: 19.61 dBm (0.0914 W) IEEE 802.11ac VHT20 Mode: 17.05 dBm (0.0507 W) IEEE 802.11ac VHT40 Mode: 19.80 dBm (0.0955 W) IEEE 802.11ac VHT80 Mode: 22.06 dBm (0.1607 W) IEEE 802.11ax HE20 Mode: 17.21 dBm (0.0507 W) IEEE 802.11ax HE40 Mode: 19.98 dBm (0.0955 W) IEEE 802.11ax HE80 Mode: 22.44 dBm (0.1607 W)</p>
Modulation Type	OFDM
Received Date	2020/08/19
Date of Test	2020/10/15 - 2020/11/03
Related Submittal(s)/Grant(s)	FCC Part 15.247 DTS with FCC ID: LNQT3280

**All measurement and test data in this report was gathered from production sample serial number: 200729001 Assigned by BACL, Linkou Laboratory).*

1.2 Operation Condition of EUT

Power Operation (Voltage Range)	<input checked="" type="checkbox"/> AC 120 V/60 Hz <input checked="" type="checkbox"/> Adapter <i>Brand Name: Actiontec</i> <i>Model: CSD024T-W120U</i> <i>I/P: 120Vac, 50/60Hz, 0.58A</i> <i>O/P: 12Vdc, 2A</i> <input type="checkbox"/> By Power Cord.
	<input type="checkbox"/> DC Type <input type="checkbox"/> DC Power <input type="checkbox"/> Battery <input type="checkbox"/> External from USB Cable <input type="checkbox"/> External DC Adapter
	<input type="checkbox"/> Host System

1.3 Objective

The Objective of this Test Report was to document the compliance of the Actiontec Electronics Inc. Appliance (Model:T3280) to the requirements of the following Standards:

- Part 2, Subpart J, Part 15 Subparts A and E of the Federal Communication Commission’s rules.
- KDB 662911 D01 Multiple Transmitter Output v02r01
- KDB 789033 D02 General U-NII Test Procedures New Rules v02r01
- ANSI C63.10-2013 of t American National Standard of Procedures for Compliance Testing of Unlicensed Wireless Devices.

1.4 Measurement Uncertainty

Parameter	Expanded Measurement uncertainty
RF output power	± 1.488 dB
Occupied Channel Bandwidth	± 453.927 Hz
RF Conducted Emission test	± 2.77 dB
AC Power Line Conducted Emission	± 2.66 dB
Radiated Below 1G	± 3.57 dB
Radiated Above 1G	± 5.32 dB

The test results with statement of conformity, the decision rules are based on the specifications and standards. The test results will not take the measurement uncertainty into account.

1.5 Environmental Conditions and Test Date

Test Site	Test Date	Temperature (°C)	Relative Humidity (%)	Test Engineer
Conduction (Con-01)	2020/10/20	24.4	52	Brian Chang
Radiated (966A)	2020/10/26 - 2020/10/28	20.8 - 22	52 - 54	Leo Cheng
Conducted (TH-02)	2020/10/15 - 2020/11/03	22.5 - 23.2	55 - 60	Blake Wang

1.6 Test Facility

The Test site used by Bay Area Compliance Laboratories Corp. (Linkou Laboratory) to collect test data is located on

No.6, Wende 2Rd., Guishan Dist., Taoyuan City 33382, Taiwan (R.O.C.).

Bay Area Compliance Laboratories Corp. (Linkou Laboratory) Lab is accredited to ISO 17025 by Taiwan Accreditation Foundation (TAF code: 3546) by Mutual Recognition Agreement (MRA). The test site has been approved by the FCC under the KDB 974614 D01 and is listed in the FCC Public Access Link (PAL) database. The FCC Registration No.: 0027578244. Designation No.: TW1119. The Test Firm Registration No.: 311381. ISED#: 25102 and CAB identifier is TW3546.

2 System Test Configuration

2.1 Description of Test Configuration

The system was configured for testing in testing mode which was provided by manufacturer.

No special accessory, No modification was made to the EUT and No special equipment used during test.

IEEE 802.11 a/n HT20/ac VHT20/ax HE20			
Channel	Frequency (MHz)	Channel	Frequency (MHz)
52	5260	100	5500
56	5280	116	5580
60	5300	140	5700
64	5320	144	5720

For UNII-2a: Channel **52, 60** and **64** were tested.

For UNII-2c a mode: Channel **100, 116** and **140** were tested.

For UNII-2c n HT20/ac VHT20/ax HE20 mode: Channel **100, 116,140** and **144** were tested.

IEEE 802.11 n HT40/ac VHT40/ax HE40			
Channel	Frequency (MHz)	Channel	Frequency (MHz)
54	5270	102	5510
62	5310	110	5550
-	-	134	5670
-	-	142	5710

For UNII-2a: Channel **54** and **62** were tested.

For UNII-2c: Channel **102, 110, 134** and **142** were tested.

IEEE 802.11 ac VHT80/ax HE80			
Channel	Frequency (MHz)	Channel	Frequency (MHz)
58	5290	106	5530
-	-	122	5610
-	-	138	5690

For UNII-2a: Channel **58** was tested.

For UNII-2c: Channel **106, 122** and **138** was tested.

Modulation Used for Conformance Test			
Configuration	N _{TX}	Data Rate	Worst Data Rate
802.11a mode	4	6-54 Mbps	6 Mbps
802.11n HT20 mode	4	MCS 0-7	MCS 0
802.11n HT40 mode	4	MCS 0-7	MCS 0
802.11ac VHT20 mode	4	MCS 0-8 NSS1	MCS 0

Modulation Used for Conformance Test			
Configuration	N _{TX}	Data Rate	Worst Data Rate
802.11ac VHT40 mode	4	MCS 0-9 NSS1	MCS 0
802.11ac VHT80 mode	4	MCS 0-9 NSS1	MCS 0
802.11ax HE20 mode	4	MCS 0-11 NSS1	MCS 0
802.11ax HE40 mode	4	MCS 0-11 NSS1	MCS 0
802.11ax HE80 mode	4	MCS 0-11 NSS1	MCS 0

Worst Case of Power Setting						
EUT Exercise Software			EngineerModeaccessMTool_REL_3_1_0_1			
Configuration	N _{TX}	UNII Band	Low CH	Mid CH	High CH	Cross Band
802.11a mode	4	UNII-2a	59	59	59	-
		UNII-2c	45	47	47	-
802.11n HT20 mode	4	UNII-2a	59	59	60	-
		UNII-2c	49	52	49	49
802.11n HT40 mode	4	UNII-2a	71	-	66	-
		UNII-2c	60	60	60	61
802.11ac VHT20 mode	4	UNII-2a	59	59	60	-
		UNII-2c	49	52	49	49
802.11ac VHT40 mode	4	UNII-2a	71	-	66	-
		UNII-2c	60	60	60	61
802.11ac VHT80 mode	4	UNII-2a	-	66	-	-
		UNII-2c	66	70	71	-
802.11ax HE20 mode	4	UNII-2a	59	59	60	-
		UNII-2c	49	52	49	49
802.11ax HE40 mode	4	UNII-2a	71	-	66	-
		UNII-2c	60	60	60	61
802.11ax HE80 mode	4	UNII-2a	-	66	-	-
		UNII-2c	66	70	71	-

- The worst-case data rates are determined to be as follows for each mode based upon investigation by measuring the Peak power and PSD across all data rates bandwidths, and modulations. Radiated below 1G were tested worst output power mode.
- Due to 802.11n HT20/n HT40/ac VHT20/ac VHT40/ac VHT80 mode output power are less than 802.11ax HE20/ax HE40/ax HE80. Therefore, 802.11ax HE20/ax HE40/ax HE80 cover 802.11n HT20/n HT40/ac VHT20/ac VHT40/ac VHT80 in the test, Include conducted and radiated, except power test

2.2 Support Equipment and External Cable List

Equipment List:

No.	Description	Manufacturer	Model Number
A	Notebook	DELL	Latitude E6410
B	NB	DELL	Latitude E5470
C	DSL	Broadcom	BCM96358MG-CO
D	NB	DELL	Latitude E5470
E	USB Flash	Kingston	16GB
F	LAN LOAD	NA	NA
G	ADAPTER	Actiontec	CDS024T-W120U

Cable List:

No.	Description	Shielded Type	Ferrite Core	Length (M)	Remark
1	LAN Cable	Non-Shielded	NA	1.8	EUT
2	LAN Cable	Non-Shielded	NA	10	
3	RJ-11 Cable	Non-Shielded	NA	3.6	EUT
4	LAN Cable	Non-Shielded	NA	1.8	
5	LAN Cable*3	Non-Shielded	NA	1.5	
6	DC Cable	Non-Shielded	NA	1.8	
7	LAN Cable	Non-Shielded	NA	10	
8	RJ-11 Cable	Non-Shielded	NA	10	

2.3 Block Diagram of Test Setup

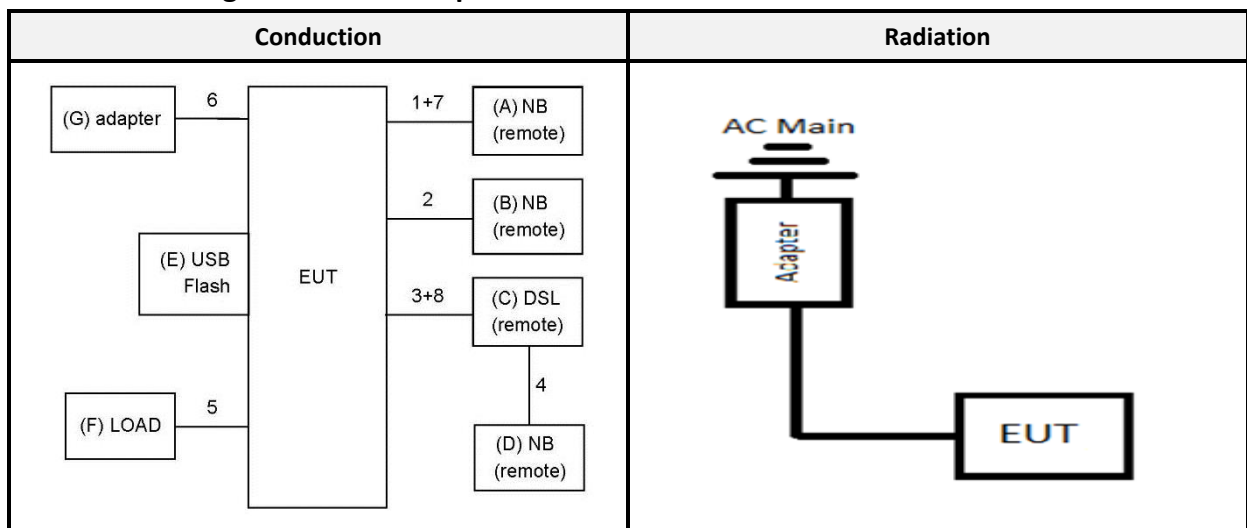

2.4 Duty Cycle

According to KDB 789033 D02 General UNII Test Procedures New Rules v02r01 section B:

All measurements are to be performed with the EUT transmitting at 100% duty cycle at its maximum power control level; however, if 100% duty cycle cannot be achieved, measurements of duty cycle, x, and maximum power transmission duration, T, are required for each tested mode of operation.

Configuration	Duty Cycle (%)	On Time (ms)	Period (ms)	Duty Factor (dB)
802.11a mode	96.66	2.10	2.17	0.15
802.11n HT20 mode	96.43	1.96	2.03	0.16
802.11n HT40 mode	94.44	0.99	1.04	0.25
802.11ac VHT20 mode	99.26	1.94	1.96	0.03
802.11ac VHT40 mode	98.52	0.96	0.98	0.06
802.11ac VHT80 mode	97.01	0.47	0.49	0.13
802.11ax HE20 mode	99.05	1.51	1.52	0.04
802.11ax HE40 mode	98.18	0.78	0.80	0.08
802.11ax HE80 mode	95.00	0.41	0.43	0.22

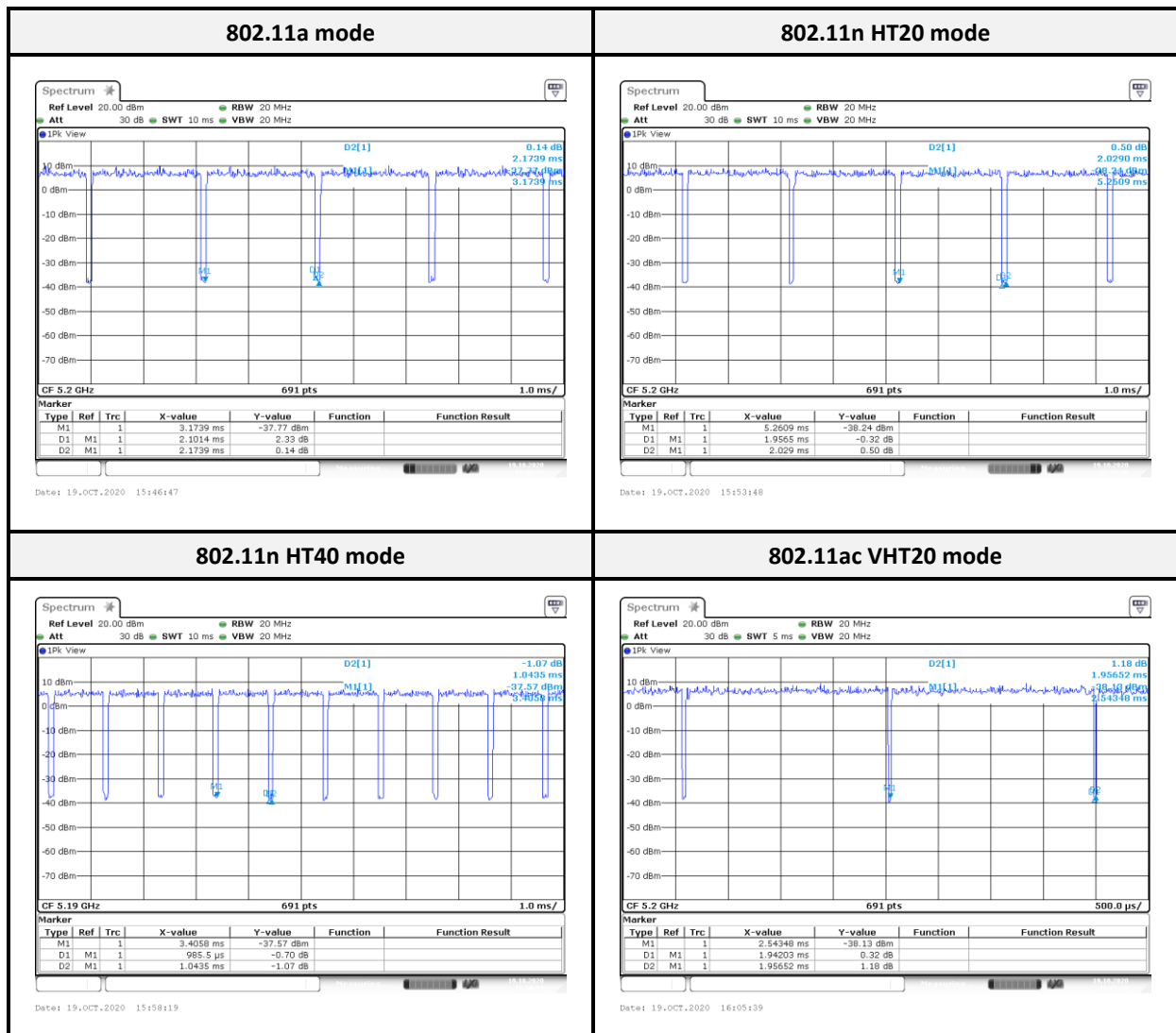

802.11ac VHT40 mode

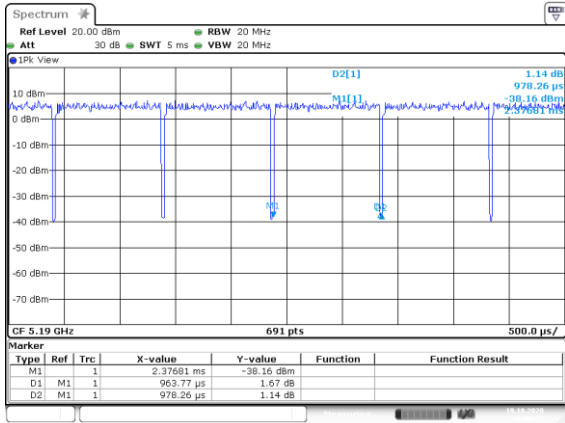

Date: 19.OCT.2020 16:06:50

802.11ac VHT80 mode

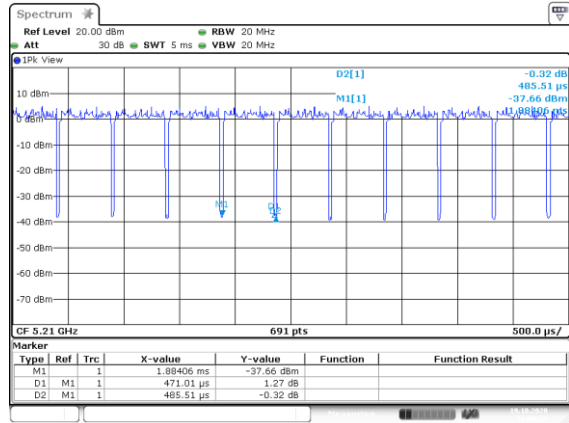

Date: 19.OCT.2020 16:08:24

802.11ax HE20 mode

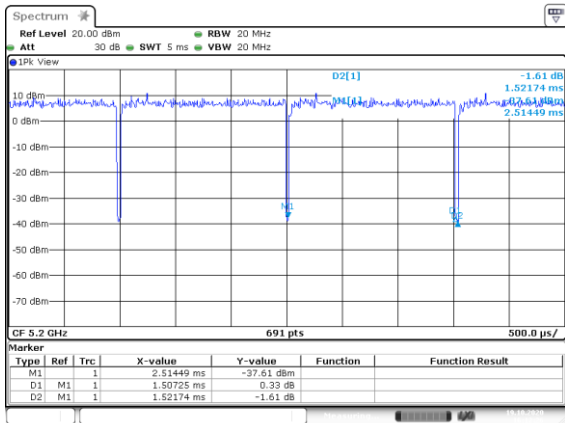

Date: 19.OCT.2020 16:12:26

802.11ax HE40 mode

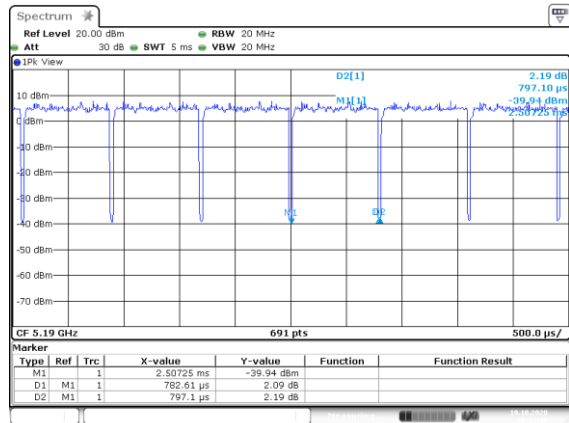

Date: 19.OCT.2020 16:13:18

802.11ax HE80 mode

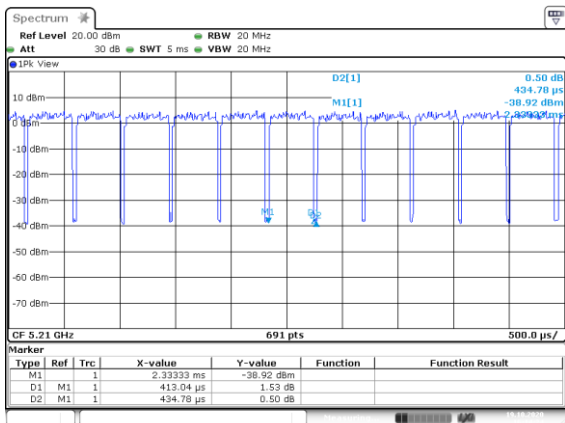

Date: 19.OCT.2020 16:14:24

3 Summary of Test Results

FCC Rules	Description of Test	Result
§1.1310, §2.1091, §15.407 (f)	Maximum Permissible Exposure (MPE)	Compliance
§15.203	Antenna Requirement	Compliance
§15.207(a), §15.407(b)(6)	AC Line Conducted Emissions	Compliance
§15.205, §15.209, §15.407(b)	Spurious Emissions	Compliance
§15.407(a)(e)	Emission Bandwidth	Compliance
§15.407(a)(1)	Maximum Peak Output Power	Compliance
§15.407(a)(1)(5)	Power Spectral Density	Compliance

4 FCC §1.1310, §2.1091, §15.407(f) - Maximum Permissible Exposure (MPE)

4.1 Applicable Standard

According to §15.407(f), U-NII devices are subject to the radio frequency radiation exposure requirements specified in § 1.1307(b), and 2.1091 of this chapter, as appropriate. All equipment shall be considered to operate in a "general population/uncontrolled" environment. Applications for equipment authorization of devices operating under this section must contain a statement confirming compliance with these requirements for both fundamental emissions and unwanted emissions. Technical information showing the basis for this statement must be submitted to the Commission upon request

Limits for Maximum Permissible Exposure (MPE) (§1.1310, §2.1091)

(B) Limits for General Population/Uncontrolled Exposure				
Frequency Range (MHz)	Electric Field Strength (V/m)	Magnetic Field Strength (A/m)	Power Density (mW/cm²)	Averaging Time (minutes)
0.3–1.34	614	1.63	*(100)	30
1.34–30	824/f	2.19/f	*(180/f ²)	30
30–300	27.5	0.073	0.2	30
300–1500	/	/	f/1500	30
1500–100,000	/	/	1.0	30

*f = frequency in MHz; * = Plane-wave equivalent power density;*

According to §1.1310 and §2.1091 RF exposure is calculated.

Calculated Formulary: Predication of MPE limit at a given distance

S = PG/4πR² = power density (in appropriate units, e.g. mW/cm²);

P = power input to the antenna (in appropriate units, e.g., mW);

G = power gain of the antenna in the direction of interest relative to an isotropic radiator, the power gain factor, is normally numeric gain;

R = distance to the center of radiation of the antenna (appropriate units, e.g., cm);

For simultaneously transmit system, the calculated power density should comply with:

$$\sum_i \frac{S_i}{S_{Limit,i}} \leq 1$$

4.2 RF Exposure Evaluation Result

MPE Evaluation:

Mode	Frequency Range (MHz)	Antenna Gain		Target Power		Evaluation Distance (cm)	Power Density (mW/cm ²)	MPE Limit (mW/cm ²)
		(dBi)	(numeric)	(dBm)	(mW)			
Wi-Fi 2.4G	2412-2462	3.93	2.4717	28.50	707.9458	20	0.3483	1.0
UNII-1	5150-5250	4.12	2.5823	28.00	630.9573	20	0.3243	1.0
UNII-2a	5250-5350	4.49	2.8119	23.00	199.5262	20	0.1117	1.0
UNII-2c	5470-5725	4.95	3.1261	23.00	199.5262	20	0.1242	1.0
UNII-3	5745-5850	4.95	3.1261	29.50	891.2509	20	0.5546	1.0

Note: Wi-Fi 2.4G and Wi-Fi 5G can't simultaneously.

Result: MPE evaluation of single and simultaneous transmission meet the requirement of standard.

5 FCC §15.203 – Antenna Requirements

5.1 Applicable Standard

According to § 15.203 and § 15.407(a)(3),

An intentional radiator shall be designed to ensure that no antenna other than that furnished by the responsible party shall be used with the device.

The use of a permanently attached antenna or of an antenna that uses a unique coupling to the intentional radiator shall be considered sufficient to comply with the provisions of this section. The manufacturer may design the unit so that a broken antenna can be replaced by the user, but the user of a standard antenna jack or electrical connector is prohibited.

If transmitting antennas of directional gain greater than 6 dBi are used, both the maximum conducted output power and the maximum power spectral density shall be reduced by the amount in dB that the directional gain of the antenna exceeds 6 dBi. However, fixed point-to-point U-NII devices operating in this band may employ transmitting antennas with directional gain greater than 6 dBi without any corresponding reduction in transmitter conducted power. Fixed, point-to-point operations exclude the use of point-to-multipoint systems, omnidirectional applications, and multiple collocated transmitters transmitting the same information. The operator of the U-NII device, or if the equipment is professionally installed, the installer, is responsible for ensuring that systems employing high gain directional antennas are used exclusively for fixed, point-to-point operations.

5.2 Antenna List and Details

Configuration	Antenna Type	Brand	Model	Antenna Gain (dBi)	Result
UNII-2a:	Internal Antenna	CALTRONICS	HB1	4.49	Compliance
	Internal Antenna	CALTRONICS	HB2	4.31	Compliance
	Internal Antenna	CALTRONICS	HB3	-8.39	Compliance
	Internal Antenna	CALTRONICS	HB3	-4.16	Compliance
UNII-2c:	Internal Antenna	CALTRONICS	HB1	4.49	Compliance
	Internal Antenna	CALTRONICS	HB2	4.95	Compliance
	Internal Antenna	CALTRONICS	HB3	-5.31	Compliance
	Internal Antenna	CALTRONICS	HB3	-3.99	Compliance

The EUT has an internal dedicated antennas arrangement, fulfill the requirement of this section.

6 FCC §15.207 - AC Line Conducted Emissions

6.1 Applicable Standard

According to FCC §15.207 and §15.407(b)(6),

For an intentional radiator that is designed to be connected to the public utility (AC) power line, the radio frequency voltage that is conducted back onto the AC power line on any frequency or frequencies within the band 150 kHz to 30 MHz shall not exceed the limits in the following table, as measured using a 50 μH/50 ohms line impedance stabilization network (LISN). Compliance with the provisions of this paragraph shall be based on the measurement of the radio frequency voltage between each power line and ground at the power terminal. The lower limit applies at the boundary between the frequencies ranges.

Frequency (MHz)	Conducted Limit (dBuV)	
	Quasi-Peak	Average
0.15-0.5	66 to 56 ^{Note 1}	56 to 46 ^{Note 2}
0.5-5	56	46
5-30	60	50

Note 1: Decreases with the logarithm of the frequency. Note 2: A linear average detector is required

6.2 EUT Setup and Test Procedure

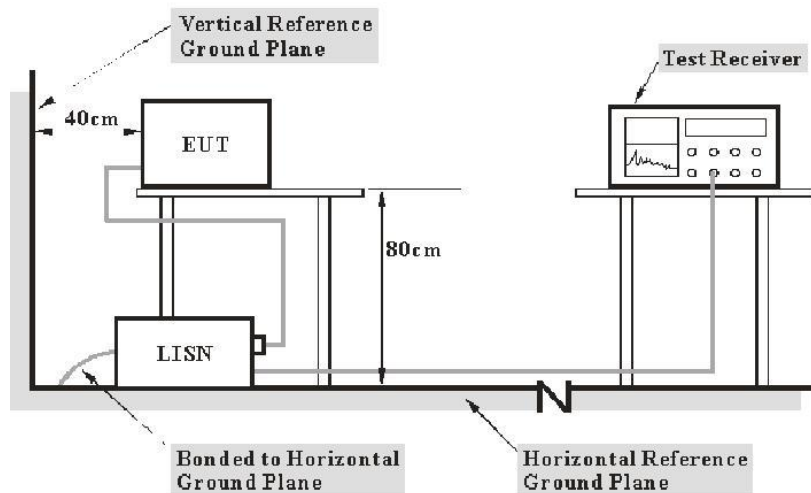

Note: 1. Support units were connected to second LISN.
 2. Both of LISNs (AMN) 80 cm from EUT and at the least 80 cm from other units and other metal planes support units.

The setup of EUT is according with per ANSI C63.10-2013 measurement procedure. The specification used was with the FCC Part 15.207 limits

The EMI test receiver was set to investigate the spectrum from 150 kHz to 30 MHz. During the conducted emission test, the EMI test receiver was set with the following configurations

Frequency Range	Receiver RBW
150 kHz - 30 MHz	9 kHz

During the conducted emission test, the adapter was connected to the outlet of the LISN. Maximizing procedure was performed on the six (6) highest emissions of the EUT. All data was recorded in the Quasi-peak and average detection mode.

6.3 Test Equipment List and Details

Description	Manufacture	Model	Serial No.	Cal. Date.	Cal. Due.
Conduction Room					
LISN	Rohde & Schwarz	ENV216	100010	2020/09/14	2021/09/13
EMI Test Receiver	Rohde & Schwarz	ESR3	102430	2020/05/07	2021/05/06
Pulse Limiter	SCHWARZBECK	VSTD 9561-F	00432	2020/09/11	2021/09/10
RF Cable	EMCI	EMCCFD300-BM-BM-8000	180526	2020/08/18	2021/08/17
Software	Audix	e3 v9	E3LK-03	N.C.R	N.C.R

***Statement of Traceability:** The testing equipment's listed above have finished the calibration by Electronics Testing Center, Taiwan (ETC) or other laboratories which were accredited by TAF or equivalent organizations. The calibration result could be traceable to the International System of Units (SI).

6.4 Test Data and Test Plot

Line		Neutral																																																																																																																																																																																																																																	
<table border="1"> <thead> <tr> <th>Line</th> <th>Freq</th> <th>Read Level</th> <th>Level</th> <th>Factor</th> <th>Limit Line</th> <th>Over Limit</th> <th>Remark</th> </tr> <tr> <th></th> <th>MHz</th> <th>dBuV</th> <th>dBuV</th> <th>dB</th> <th>dBuV</th> <th>dB</th> <th></th> </tr> </thead> <tbody> <tr><td>1</td><td>0.150</td><td>37.11</td><td>56.97</td><td>19.86</td><td>66.00</td><td>-9.03</td><td>QP</td></tr> <tr><td>2</td><td>0.150</td><td>17.75</td><td>37.61</td><td>19.86</td><td>56.00</td><td>-18.39</td><td>Average</td></tr> <tr><td>3</td><td>0.176</td><td>34.89</td><td>53.95</td><td>19.06</td><td>64.68</td><td>-10.73</td><td>QP</td></tr> <tr><td>4</td><td>0.176</td><td>14.65</td><td>34.51</td><td>19.86</td><td>54.68</td><td>-20.17</td><td>Average</td></tr> <tr><td>5</td><td>0.189</td><td>31.24</td><td>51.11</td><td>19.87</td><td>64.08</td><td>-12.97</td><td>QP</td></tr> <tr><td>6</td><td>0.189</td><td>12.86</td><td>31.93</td><td>19.87</td><td>54.08</td><td>-22.15</td><td>Average</td></tr> <tr><td>7</td><td>0.605</td><td>27.21</td><td>47.09</td><td>19.88</td><td>56.00</td><td>-8.91</td><td>QP</td></tr> <tr><td>8</td><td>0.605</td><td>18.48</td><td>38.36</td><td>19.88</td><td>46.00</td><td>-7.64</td><td>Average</td></tr> <tr><td>9</td><td>12.893</td><td>22.19</td><td>42.44</td><td>20.25</td><td>60.00</td><td>-17.56</td><td>QP</td></tr> <tr><td>10</td><td>12.893</td><td>15.50</td><td>35.75</td><td>20.25</td><td>50.00</td><td>-14.25</td><td>Average</td></tr> <tr><td>11</td><td>18.600</td><td>18.56</td><td>38.89</td><td>20.33</td><td>60.00</td><td>-21.11</td><td>QP</td></tr> <tr><td>12</td><td>18.600</td><td>13.29</td><td>33.62</td><td>20.33</td><td>50.00</td><td>-16.38</td><td>Average</td></tr> </tbody> </table>		Line	Freq	Read Level	Level	Factor	Limit Line	Over Limit	Remark		MHz	dBuV	dBuV	dB	dBuV	dB		1	0.150	37.11	56.97	19.86	66.00	-9.03	QP	2	0.150	17.75	37.61	19.86	56.00	-18.39	Average	3	0.176	34.89	53.95	19.06	64.68	-10.73	QP	4	0.176	14.65	34.51	19.86	54.68	-20.17	Average	5	0.189	31.24	51.11	19.87	64.08	-12.97	QP	6	0.189	12.86	31.93	19.87	54.08	-22.15	Average	7	0.605	27.21	47.09	19.88	56.00	-8.91	QP	8	0.605	18.48	38.36	19.88	46.00	-7.64	Average	9	12.893	22.19	42.44	20.25	60.00	-17.56	QP	10	12.893	15.50	35.75	20.25	50.00	-14.25	Average	11	18.600	18.56	38.89	20.33	60.00	-21.11	QP	12	18.600	13.29	33.62	20.33	50.00	-16.38	Average	<table border="1"> <thead> <tr> <th>Line</th> <th>Freq</th> <th>Read Level</th> <th>Level</th> <th>Factor</th> <th>Limit Line</th> <th>Over Limit</th> <th>Remark</th> </tr> <tr> <th></th> <th>MHz</th> <th>dBuV</th> <th>dBuV</th> <th>dB</th> <th>dBuV</th> <th>dB</th> <th></th> </tr> </thead> <tbody> <tr><td>1</td><td>0.151</td><td>37.36</td><td>57.23</td><td>19.87</td><td>65.93</td><td>-8.70</td><td>QP</td></tr> <tr><td>2</td><td>0.151</td><td>16.86</td><td>36.73</td><td>19.87</td><td>55.93</td><td>-19.20</td><td>Average</td></tr> <tr><td>3</td><td>0.168</td><td>35.18</td><td>55.05</td><td>19.87</td><td>65.07</td><td>-10.02</td><td>QP</td></tr> <tr><td>4</td><td>0.168</td><td>15.95</td><td>35.82</td><td>19.87</td><td>55.07</td><td>-19.25</td><td>Average</td></tr> <tr><td>5</td><td>0.192</td><td>30.24</td><td>50.12</td><td>19.88</td><td>63.95</td><td>-13.83</td><td>QP</td></tr> <tr><td>6</td><td>0.192</td><td>11.37</td><td>31.25</td><td>19.88</td><td>53.95</td><td>-22.70</td><td>Average</td></tr> <tr><td>7</td><td>0.591</td><td>27.43</td><td>47.32</td><td>19.89</td><td>56.00</td><td>-8.68</td><td>QP</td></tr> <tr><td>8</td><td>0.591</td><td>19.33</td><td>39.22</td><td>19.89</td><td>46.00</td><td>-6.78</td><td>Average</td></tr> <tr><td>9</td><td>12.996</td><td>23.07</td><td>43.38</td><td>20.31</td><td>60.00</td><td>-16.62</td><td>QP</td></tr> <tr><td>10</td><td>12.996</td><td>16.17</td><td>36.48</td><td>20.31</td><td>50.00</td><td>-13.52</td><td>Average</td></tr> <tr><td>11</td><td>18.899</td><td>19.46</td><td>39.89</td><td>20.43</td><td>60.00</td><td>-20.11</td><td>QP</td></tr> <tr><td>12</td><td>18.899</td><td>13.91</td><td>34.34</td><td>20.43</td><td>50.00</td><td>-15.66</td><td>Average</td></tr> </tbody> </table>		Line	Freq	Read Level	Level	Factor	Limit Line	Over Limit	Remark		MHz	dBuV	dBuV	dB	dBuV	dB		1	0.151	37.36	57.23	19.87	65.93	-8.70	QP	2	0.151	16.86	36.73	19.87	55.93	-19.20	Average	3	0.168	35.18	55.05	19.87	65.07	-10.02	QP	4	0.168	15.95	35.82	19.87	55.07	-19.25	Average	5	0.192	30.24	50.12	19.88	63.95	-13.83	QP	6	0.192	11.37	31.25	19.88	53.95	-22.70	Average	7	0.591	27.43	47.32	19.89	56.00	-8.68	QP	8	0.591	19.33	39.22	19.89	46.00	-6.78	Average	9	12.996	23.07	43.38	20.31	60.00	-16.62	QP	10	12.996	16.17	36.48	20.31	50.00	-13.52	Average	11	18.899	19.46	39.89	20.43	60.00	-20.11	QP	12	18.899	13.91	34.34	20.43	50.00	-15.66	Average
Line	Freq	Read Level	Level	Factor	Limit Line	Over Limit	Remark																																																																																																																																																																																																																												
	MHz	dBuV	dBuV	dB	dBuV	dB																																																																																																																																																																																																																													
1	0.150	37.11	56.97	19.86	66.00	-9.03	QP																																																																																																																																																																																																																												
2	0.150	17.75	37.61	19.86	56.00	-18.39	Average																																																																																																																																																																																																																												
3	0.176	34.89	53.95	19.06	64.68	-10.73	QP																																																																																																																																																																																																																												
4	0.176	14.65	34.51	19.86	54.68	-20.17	Average																																																																																																																																																																																																																												
5	0.189	31.24	51.11	19.87	64.08	-12.97	QP																																																																																																																																																																																																																												
6	0.189	12.86	31.93	19.87	54.08	-22.15	Average																																																																																																																																																																																																																												
7	0.605	27.21	47.09	19.88	56.00	-8.91	QP																																																																																																																																																																																																																												
8	0.605	18.48	38.36	19.88	46.00	-7.64	Average																																																																																																																																																																																																																												
9	12.893	22.19	42.44	20.25	60.00	-17.56	QP																																																																																																																																																																																																																												
10	12.893	15.50	35.75	20.25	50.00	-14.25	Average																																																																																																																																																																																																																												
11	18.600	18.56	38.89	20.33	60.00	-21.11	QP																																																																																																																																																																																																																												
12	18.600	13.29	33.62	20.33	50.00	-16.38	Average																																																																																																																																																																																																																												
Line	Freq	Read Level	Level	Factor	Limit Line	Over Limit	Remark																																																																																																																																																																																																																												
	MHz	dBuV	dBuV	dB	dBuV	dB																																																																																																																																																																																																																													
1	0.151	37.36	57.23	19.87	65.93	-8.70	QP																																																																																																																																																																																																																												
2	0.151	16.86	36.73	19.87	55.93	-19.20	Average																																																																																																																																																																																																																												
3	0.168	35.18	55.05	19.87	65.07	-10.02	QP																																																																																																																																																																																																																												
4	0.168	15.95	35.82	19.87	55.07	-19.25	Average																																																																																																																																																																																																																												
5	0.192	30.24	50.12	19.88	63.95	-13.83	QP																																																																																																																																																																																																																												
6	0.192	11.37	31.25	19.88	53.95	-22.70	Average																																																																																																																																																																																																																												
7	0.591	27.43	47.32	19.89	56.00	-8.68	QP																																																																																																																																																																																																																												
8	0.591	19.33	39.22	19.89	46.00	-6.78	Average																																																																																																																																																																																																																												
9	12.996	23.07	43.38	20.31	60.00	-16.62	QP																																																																																																																																																																																																																												
10	12.996	16.17	36.48	20.31	50.00	-13.52	Average																																																																																																																																																																																																																												
11	18.899	19.46	39.89	20.43	60.00	-20.11	QP																																																																																																																																																																																																																												
12	18.899	13.91	34.34	20.43	50.00	-15.66	Average																																																																																																																																																																																																																												

Note:

Level = Read Level + Factor

Over Limit (Margin) = Level – Limit Line

Factor = (LISN, ISN, PLC or current probe) Factor + Cable Loss + Attenuator

7 FCC §15.209, §15.205 & §15.407(b) – Unwanted Emission

7.1 Applicable Standard

According to FCC §15.407(b),

Undesirable emission limits. Except as shown in paragraph (b) (7) of this section, the maximum emissions outside of the frequency bands of operation shall be attenuated in accordance with the following limits:

- (1) For transmitters operating in the 5.15-5.25 GHz band: All emissions outside of the 5.15-5.35 GHz band shall not exceed an e.i.r.p. of -27 dBm/MHz.
- (2) For transmitters operating in the 5.25-5.35 GHz band: All emissions outside of the 5.15-5.35 GHz band shall not exceed an e.i.r.p. of -27 dBm/MHz.
- (3) For transmitters operating in the 5.47-5.725 GHz band: All emissions outside of the 5.47-5.725 GHz band shall not exceed an e.i.r.p. of -27 dBm/MHz.
- (4) For transmitters operating in the 5.725-5.85 GHz band:
 - (i) All emissions shall be limited to a level of -27 dBm/MHz at 75 MHz or more above or below the band edge increasing linearly to 10 dBm/MHz at 25 MHz above or below the band edge, and from 25 MHz above or below the band edge increasing linearly to a level of 15.6 dBm/MHz at 5 MHz above or below the band edge, and from 5 MHz above or below the band edge increasing linearly to a level of 27 dBm/MHz at the band edge.
 - (ii) Devices certified before March 2, 2017 with antenna gain greater than 10 dBi may demonstrate compliance with the emission limits in §15.247(d), but manufacturing, marketing and importing of devices certified under this alternative must cease by March 2, 2018. Devices certified before March 2, 2018 with antenna gain of 10 dBi or less may demonstrate compliance with the emission limits in §15.247(d), but manufacturing, marketing and importing of devices certified under this alternative must cease before March 2, 2020.
- (5) The emission measurements shall be performed using a minimum resolution bandwidth of 1 MHz. A lower resolution bandwidth may be employed near the band edge, when necessary, provided the measured energy is integrated to show the total power over 1 MHz.
- (6) Unwanted emissions below 1 GHz must comply with the general field strength limits set forth in §15.209. Further.
- (7) The provisions of §15.205 apply to intentional radiators operating under this section.
- (8) When measuring the emission limits, the nominal carrier frequency shall be adjusted as close to the upper and lower frequency band edges as the design of the equipment permits.

As per FCC §15.35(d): Unless otherwise specified, on any frequency or frequencies above 1000 MHz, the radiated emission limits are based on the use of measurement instrumentation employing an average detector function. Unless otherwise specified, measurements above 1000 MHz shall be performed using a minimum resolution bandwidth of 1MHz.

As Per FCC §15.205(a) except as show in paragraph (d) of this section, only spurious emissions are permitted in any of the frequency bands listed below:

MHz	MHz	MHz	GHz
0.090-0.110	13.36-13.41	399.9-410	4.5-5.15
0.495-0.505	16.42-16.423	608-614	5.35-5.46
2.1735-2.1905	16.69475-16.69525	960-1240	7.25-7.75
4.125-4.128	25.5-25.67	1300-1427	8.025-8.5
4.17725-4.17775	37.5-38.25	1435-1626.5	9.0-9.2
4.20725-4.20775	73-74.6	1645.5-1646.5	9.3-9.5
6.215-6.218	74.8-75.2	1660-1710	10.6-12.7
6.26775-6.26825	108-121.94	1718.8-1722.2	13.25-13.4
6.31175-6.31225	123-138	2200-2300	14.47-14.5
8.291-8.294	149.9-150.05	2310-2390	15.35-16.2
8.362-8.366	156.52475-156.52525	2483.5-2500	17.7-21.4
8.37625-8.38675	156.7-156.9	2690-2900	22.01-23.12
8.41425-8.41475	162.0125-167.17	3260-3267	23.6-24.0
12.29-12.293	167.72-173.2	3332-3339	31.2-31.8
12.51975-12.52025	240-285	3345.8-3358	36.43-36.5
12.57675-12.57725	322-335.4	3600-4400	Above 38.6

As per FCC §15.209(a): Except as provided elsewhere in this Subpart, the emissions from an intentional radiator shall not exceed the field strength levels specified in the following table:

Frequency (MHz)	Field Strength (micro volts/meter)	Measurement Distance (meters)
0.009 - 0.490	2400/F(kHz)	300
0.490 - 1.705	24000/F(kHz)	30
1.705 - 30.0	30	30
30 - 88	100**	3
88 - 216	150**	3
216 - 960	200**	3
Above 960	500	3

** Except as provided in paragraph (g), fundamental emissions from intentional radiators operating under this Section shall not be located in the frequency bands 54-72 MHz, 76-88 MHz, 174-216 MHz or 470-806MHz. However, operation within these frequency bands is permitted under other sections of this Part, e.g., Sections 15.231 and 15.241.

7.2 EUT Setup and Test Procedure

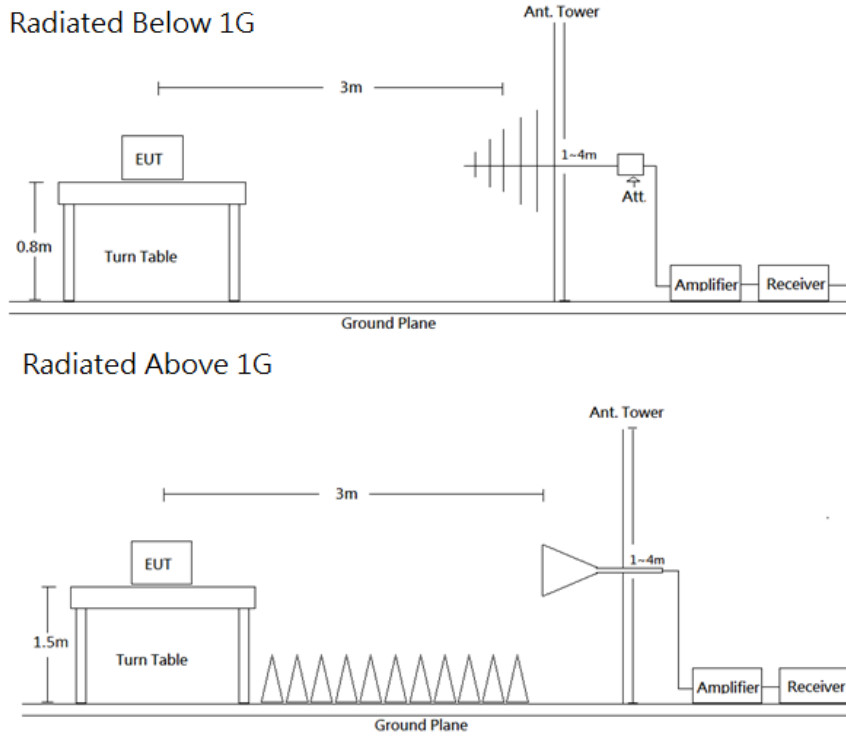

Radiated emission tests were performed in the 3 meters chamber test site, using the setup accordance with the ANSI C63.10-2013. The specification used was the FCC Part 15.209 and FCC 15.407 Limits.

The system was investigated from 30 MHz to 40 GHz. During the radiated emission test, the EMI test receiver was set with the following configurations measurement method 6.3 in ANSI C63.10-2013.

Frequency Range	RBW	VBW	Detector	Duty cycle	Measurement method
30-1000 MHz	120 kHz	/	QP	-	QP
Above 1 GHz	1 MHz	3 MHz	PK	-	PK
	1 MHz	3 MHz	RMS	>98%	Ave
	1 MHz	1/T	PK	<98%	Ave

Maximizing procedure was performed on the highest emissions to ensure that the EUT complied with all installation combinations. All data was recorded in the Quasi-peak detector mode from 30 MHz to 1 GHz and PK and average detector modes for frequencies above 1 GHz.

7.3 Test Equipment List and Details

Description	Manufacture	Model	Serial No.	Cal. Date.	Cal. Due.
966A Room					
Active Loop Antenna	EMCO	6502	0001-3322	2020/03/16	2021/03/15
Bilog Antenna/6 dB Attenuator	SUNOL SCIENCES & EMEC /EMCI	JB3/N-6-06	A111513/AT-N0668	2020/03/19	2021/03/18
Horn Antenna	ETS-Lindgren	3115	00109141	2020/07/15	2021/07/14
Horn Antenna	ETS-Lindgren	3160-09	00123852	2020/07/07	2021/07/06
Horn Antenna	ETS-Lindgren	3160-10	00123855	2020/07/07	2021/07/06
Preamplifier	A.H. Systems	PAM-0118P	478	2020/05/05	2021/05/04
Preamplifier	A.H. Systems	PAM-1840VH	174	2020/03/25	2021/03/24
Signal and Spectrum Analyzer	Rohde & Schwarz	FSV40	101434	2020/05/07	2021/05/06
Microflex Cable (1m)	EMCI	EMC106-SM-SM-2000	180515	2020/08/06	2021/08/05
Microflex Cable (2m)	MTJ	H0919	00000-MT28A-100	2020/08/06	2021/08/05
Microflex Cable (8m)	UTIFLEX	UFA210A-1-3149-300300	MFR 64639 232490-001	2020/08/06	2021/08/05
Turn Table	Chaintek	T-200-S-1	003501	N.C.R	N.C.R
Antenna Tower	Chaintek	MBD-400-1	003504	N.C.R	N.C.R
Controller	Chaintek	3000-1	003507	N.C.R	N.C.R
Software	Audix	e3 v9	E3LK-01	N.C.R	N.C.R

***Statement of Traceability:** The testing equipment's listed above have finished the calibration by Electronics Testing Center, Taiwan (ETC) or other laboratories which were accredited by TAF or equivalent organizations. The calibration result could be traceable to the International System of Units (SI).

7.4 Test Data and Test Plot

Wi-Fi 5G Mode:

Transmitting mode (Pre-scan with three orthogonal axis, and worse case as Y axis)

Below 1G (30 MHz-1 GHz) test the output power worst mode

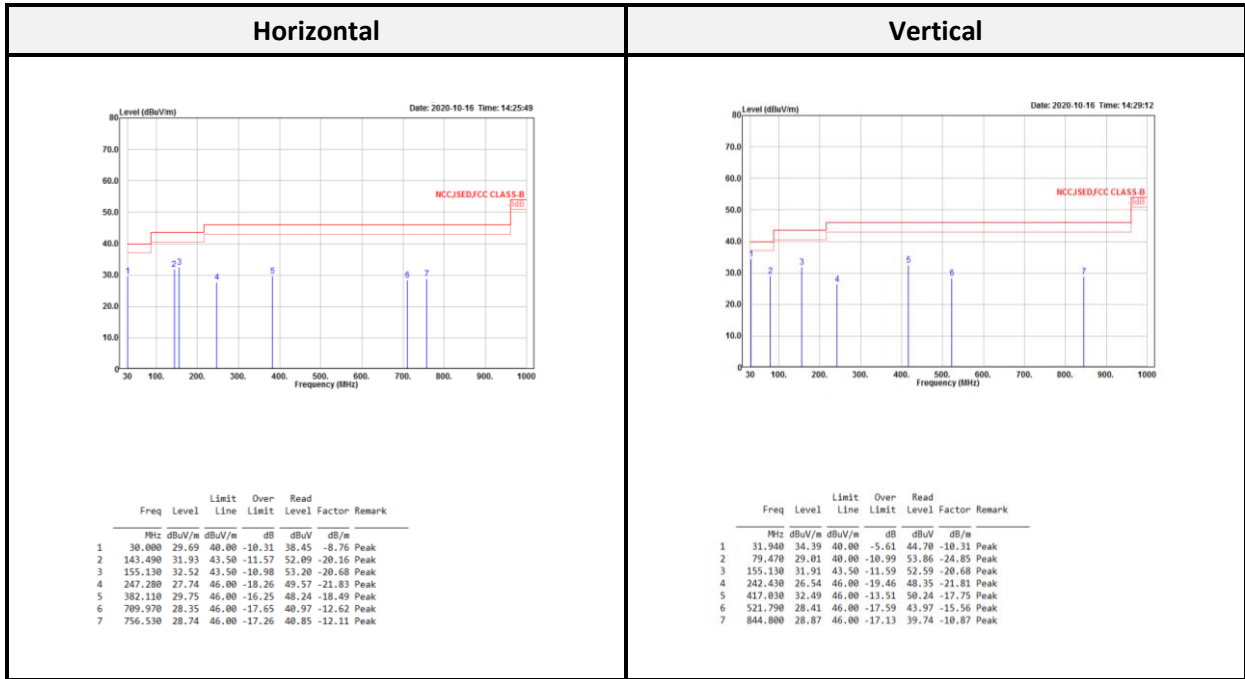

$Level = Read\ Level + Factor$

$Over\ Limit = Level - Limit$

$Correct\ Factor = Antenna\ Factor + Cable\ Loss - Amplifier\ Gain$

Spurious emissions more than 20 dB below the limit were not reported

Above 1G (1 GHz-40 GHz) in UNII-2a:

802.11a mode:

Low CH													
Horizontal							Vertical						
Freq	Level	Limit Line	Over Limit	Read Level	Factor	Remark	Freq	Level	Limit Line	Over Limit	Read Level	Factor	Remark
MHz	dBuV/m	dBuV/m	dB	dBuV	dB/m		MHz	dBuV/m	dBuV/m	dB	dBuV	dB/m	
1 !	5074.400	48.04	54.00	-5.96	50.47	-2.43 Average	1 !	5102.000	48.11	54.00	-5.89	50.52	-2.41 Average
2 !	5074.400	61.67	74.00	-12.33	64.10	-2.43 Peak	2 !	5102.000	62.22	74.00	-11.78	64.63	-2.41 Peak
3 *	5263.200	100.64			102.90	-2.26 Average	3 *	5255.600	103.92			106.21	-2.29 Average
4 *	5263.200	110.05			112.31	-2.26 Peak	4 *	5255.600	113.56			115.85	-2.29 Peak
5 !	5441.200	48.89	54.00	-5.11	50.66	-1.77 Average	5 !	5434.000	48.87	54.00	-5.13	50.66	-1.79 Average
6 !	5441.200	62.07	74.00	-11.93	63.84	-1.77 Peak	6 !	5434.000	62.37	74.00	-11.63	64.16	-1.79 Peak
1 !	10520.000	55.86	68.20	-12.34	48.84	7.02 Peak	1 !	10520.000	57.51	68.20	-10.69	50.49	7.02 Peak
2 !	115780.000	41.13	54.00	-12.87	31.34	9.79 Average	2 !	115780.000	40.91	54.00	-13.09	31.12	9.79 Average
3 !	115780.000	55.12	74.00	-18.88	45.33	9.79 Peak	3 !	115780.000	55.13	74.00	-18.87	45.34	9.79 Peak

Middle CH													
Horizontal							Vertical						
Freq	Level	Limit Line	Over Limit	Read Level	Factor	Remark	Freq	Level	Limit Line	Over Limit	Read Level	Factor	Remark
MHz	dBuV/m	dBuV/m	dB	dBuV	dB/m		MHz	dBuV/m	dBuV/m	dB	dBuV	dB/m	
1 !	5103.600	48.11	54.00	-5.89	50.52	-2.41 Average	1 !	5110.400	48.63	54.00	-5.37	51.04	-2.41 Average
2 !	5103.600	61.23	74.00	-12.77	63.64	-2.41 Peak	2 !	5110.400	61.16	74.00	-12.84	63.57	-2.41 Peak
3 *	5300.800	103.35			105.51	-2.16 Average	3 *	5294.400	103.73			105.89	-2.16 Average
4 *	5300.800	110.21			112.37	-2.16 Peak	4 *	5294.400	112.83			114.99	-2.16 Peak
5 !	5374.800	48.66	54.00	-5.34	50.61	-1.95 Average	5 !	5434.000	49.05	54.00	-4.95	50.84	-1.79 Average
6 !	5374.800	61.77	74.00	-12.23	63.72	-1.95 Peak	6 !	5434.000	62.11	74.00	-11.89	63.90	-1.79 Peak
1 !	10600.000	44.71	54.00	-9.29	37.51	7.20 Average	1 !	10600.000	48.80	54.00	-5.20	41.60	7.20 Average
2 !	10600.000	58.60	74.00	-15.40	51.40	7.20 Peak	2 !	10600.000	60.80	74.00	-13.20	53.60	7.20 Peak
3 !	115900.000	40.98	54.00	-13.02	31.18	9.80 Average	3 !	115900.000	41.17	54.00	-12.83	31.37	9.80 Average
4 !	115900.000	53.76	74.00	-20.24	43.96	9.80 Peak	4 !	115900.000	54.43	74.00	-19.57	44.63	9.80 Peak

High CH													
Horizontal							Vertical						
Freq	Level	Limit Line	Over Limit	Read Level	Factor	Remark	Freq	Level	Limit Line	Over Limit	Read Level	Factor	Remark
MHz	dBuV/m	dBuV/m	dB	dBuV	dB/m		MHz	dBuV/m	dBuV/m	dB	dBuV	dB/m	
1 *	5323.160	100.32			102.41	-2.09 Average	1 *	5315.180	103.47			105.58	-2.11 Average
2 *	5323.160	109.82			111.91	-2.09 Peak	2 *	5315.180	112.95			115.06	-2.11 Peak
3 !	5447.200	48.92	54.00	-5.08	50.67	-1.75 Average	3 !	5425.500	49.21	54.00	-4.79	51.01	-1.80 Average
4 !	5447.200	62.61	74.00	-11.39	64.36	-1.75 Peak	4 !	5425.500	62.72	74.00	-11.28	64.52	-1.80 Peak
1 !	10640.000	46.73	54.00	-7.27	39.45	7.28 Average	1 !	10640.000	48.60	54.00	-5.40	41.32	7.28 Average
2 !	10640.000	60.77	74.00	-13.23	53.49	7.28 Peak	2 !	10640.000	61.80	74.00	-12.20	54.52	7.28 Peak
3 !	115960.000	41.87	54.00	-12.13	32.04	9.83 Average	3 !	115960.000	41.69	54.00	-12.31	31.86	9.83 Average
4 !	115960.000	54.86	74.00	-19.14	45.03	9.83 Peak	4 !	115960.000	54.95	74.00	-19.05	45.12	9.83 Peak

802.11ax HE20 mode:

Low CH															
Horizontal							Vertical								
Freq	Level	Limit Line	Over Limit	Read Level	Factor	Remark	Freq	Level	Limit Line	Over Limit	Read Level	Factor	Remark		
MHz	dBuV/m	dBuV/m	dB	dBuV	dB/m		MHz	dBuV/m	dBuV/m	dB	dBuV	dB/m			
1 !	5132.400	48.11	54.00	-5.89	50.51	-2.40	Average	1 !	5136.400	48.31	54.00	-5.69	50.70	-2.39	Average
2 !	5132.400	61.86	74.00	-12.14	64.26	-2.40	Peak	2 !	5136.400	62.28	74.00	-11.72	64.67	-2.39	Peak
3 *	5265.600	97.80			100.05	-2.25	Average	3 *	5261.600	102.07			104.33	-2.26	Average
4 *	5265.600	109.90			112.15	-2.25	Peak	4 *	5261.600	114.31			116.57	-2.26	Peak
5 !	5394.800	48.58	54.00	-5.42	50.48	-1.90	Average	5 !	5415.200	48.66	54.00	-5.34	50.49	-1.83	Average
6 !	5394.800	62.65	74.00	-11.35	64.55	-1.90	Peak	6 !	5415.200	62.63	74.00	-11.37	64.46	-1.83	Peak
1 !	10520.000	57.78	68.20	-10.42	50.76	7.02	Peak	1 !	10520.000	57.00	68.20	-11.20	49.98	7.02	Peak
2 !	15780.000	42.34	54.00	-11.66	32.55	9.79	Average	2 !	15780.000	42.23	54.00	-11.77	32.44	9.79	Average
3 !	15780.000	55.59	74.00	-18.41	45.80	9.79	Peak	3 !	15780.000	54.81	74.00	-19.19	45.02	9.79	Peak

Middle CH															
Horizontal							Vertical								
Freq	Level	Limit Line	Over Limit	Read Level	Factor	Remark	Freq	Level	Limit Line	Over Limit	Read Level	Factor	Remark		
MHz	dBuV/m	dBuV/m	dB	dBuV	dB/m		MHz	dBuV/m	dBuV/m	dB	dBuV	dB/m			
1 !	5146.800	48.52	54.00	-5.48	50.90	-2.38	Average	1 !	5061.600	48.17	54.00	-5.83	50.61	-2.44	Average
2 !	5146.800	61.79	74.00	-12.21	64.17	-2.38	Peak	2 !	5061.600	62.01	74.00	-11.99	64.45	-2.44	Peak
3 *	5297.200	98.31			100.48	-2.17	Average	3 *	5299.600	101.07			103.23	-2.16	Average
4 *	5297.200	110.62			112.79	-2.17	Peak	4 *	5299.600	114.31			116.47	-2.16	Peak
5 !	5360.800	48.87	54.00	-5.13	50.86	-1.99	Average	5 !	5371.200	48.68	54.00	-5.32	50.65	-1.97	Average
6 !	5360.800	61.78	74.00	-12.22	63.77	-1.99	Peak	6 !	5371.200	63.58	74.00	-10.42	65.55	-1.97	Peak
1 !	10600.000	47.84	54.00	-6.16	40.64	7.20	Average	1 !	10600.000	47.57	54.00	-6.43	40.38	7.19	Average
2 !	10600.000	60.71	74.00	-13.29	53.51	7.20	Peak	2 !	10600.000	60.47	74.00	-13.53	53.27	7.20	Peak
3 !	15900.000	41.13	54.00	-12.87	31.33	9.80	Average	3 !	15900.000	41.30	54.00	-12.70	31.50	9.80	Average
4 !	15900.000	54.15	74.00	-19.85	44.35	9.80	Peak	4 !	15900.000	55.15	74.00	-18.85	45.35	9.80	Peak

High CH															
Horizontal							Vertical								
Freq	Level	Limit Line	Over Limit	Read Level	Factor	Remark	Freq	Level	Limit Line	Over Limit	Read Level	Factor	Remark		
MHz	dBuV/m	dBuV/m	dB	dBuV	dB/m		MHz	dBuV/m	dBuV/m	dB	dBuV	dB/m			
1 *	5317.000	98.74			100.85	-2.11	Average	1 *	5324.280	101.61			103.70	-2.09	Average
2 *	5317.000	111.47			113.58	-2.11	Peak	2 *	5324.280	113.95			116.04	-2.09	Peak
3 !	5356.060	48.62	54.00	-5.38	50.63	-2.01	Average	3 !	5430.540	49.51	54.00	-4.49	51.30	-1.79	Average
4 !	5356.060	62.51	74.00	-11.49	64.52	-2.01	Peak	4 !	5430.540	62.97	74.00	-11.03	64.76	-1.79	Peak
1 !	10640.000	48.13	54.00	-5.87	40.85	7.28	Average	1 !	10640.000	48.92	54.00	-5.08	41.64	7.28	Average
2 !	10640.000	60.26	74.00	-13.74	52.98	7.28	Peak	2 !	10640.000	61.87	74.00	-12.13	54.59	7.28	Peak
3 !	15960.000	41.64	54.00	-12.36	31.81	9.83	Average	3 !	15960.000	41.82	54.00	-12.18	31.99	9.83	Average
4 !	15960.000	55.47	74.00	-18.53	45.64	9.83	Peak	4 !	15960.000	55.81	74.00	-18.19	45.98	9.83	Peak

802.11ax HE40 mode:

Low CH													
Horizontal							Vertical						
Freq	Level	Limit Line	Over Limit	Read Level	Factor	Remark	Freq	Level	Limit Line	Over Limit	Read Level	Factor	Remark
MHz	dBuV/m	dBuV/m	dB	dBuV	dB/m		MHz	dBuV/m	dBuV/m	dB	dBuV	dB/m	
1 !	5105.200	48.43	54.00	-5.57	50.84	-2.41 Average	1 !	5051.200	48.41	54.00	-5.59	50.86	-2.45 Average
2 !	5105.200	61.80	74.00	-12.20	64.21	-2.41 Peak	2 !	5051.200	62.54	74.00	-11.46	64.99	-2.45 Peak
3 *	5280.800	97.91			100.11	-2.20 Average	3 *	5269.600	101.63			103.86	-2.23 Average
4 *	5280.800	110.15			112.35	-2.20 Peak	4 *	5269.600	113.40			115.63	-2.23 Peak
5 !	5410.800	49.01	54.00	-4.99	50.86	-1.85 Average	5 !	5416.800	49.27	54.00	-4.73	51.10	-1.83 Average
6 !	5410.800	62.43	74.00	-11.57	64.28	-1.85 Peak	6 !	5416.800	61.76	74.00	-12.24	63.59	-1.83 Peak
1 !	10540.000	59.59	68.20	-8.61	52.54	7.05 Peak	1 !	10540.000	58.23	68.20	-9.97	51.18	7.05 Peak
2 !	15810.000	42.66	54.00	-11.34	32.90	9.76 Average	2 !	15810.000	41.50	54.00	-12.50	31.74	9.76 Average
3 !	15810.000	57.71	74.00	-16.29	47.95	9.76 Peak	3 !	15810.000	54.94	74.00	-19.06	45.18	9.76 Peak

High CH													
Horizontal							Vertical						
Freq	Level	Limit Line	Over Limit	Read Level	Factor	Remark	Freq	Level	Limit Line	Over Limit	Read Level	Factor	Remark
MHz	dBuV/m	dBuV/m	dB	dBuV	dB/m		MHz	dBuV/m	dBuV/m	dB	dBuV	dB/m	
1 *	5317.360	98.09			100.20	-2.11 Average	1 *	5320.240	100.17			102.27	-2.10 Average
2 *	5317.360	111.09			113.20	-2.11 Peak	2 *	5320.240	112.44			114.54	-2.10 Peak
3 !	5352.400	51.75	54.00	-2.25	53.77	-2.02 Average	3 !	5350.320	53.22	54.00	-0.78	55.25	-2.03 Average
4 !	5352.400	66.73	74.00	-7.27	68.75	-2.02 Peak	4 !	5350.320	69.40	74.00	-4.60	71.43	-2.03 Peak
1 !	10620.000	47.60	54.00	-6.40	40.36	7.24 Average	1 !	10620.000	47.24	54.00	-6.76	40.00	7.24 Average
2 !	10620.000	59.57	74.00	-14.43	52.33	7.24 Peak	2 !	10620.000	61.10	74.00	-12.90	53.86	7.24 Peak
3 !	15930.000	41.64	54.00	-12.36	31.86	9.78 Average	3 !	15930.000	41.51	54.00	-12.49	31.73	9.78 Average
4 !	15930.000	56.38	74.00	-17.62	46.60	9.78 Peak	4 !	15930.000	54.90	74.00	-19.10	45.12	9.78 Peak

802.11ax HE80 mode:

Horizontal														Vertical						
Freq	Level	Limit Line	Over Limit	Read Level	Factor	Remark	Freq	Level	Limit Line	Over Limit	Read Level	Factor	Remark							
MHz	dBuV/m	dBuV/m	dB	dBuV	dB/m		MHz	dBuV/m	dBuV/m	dB	dBuV	dB/m								
1 *	5296.600	92.54			94.71	-2.17 Average	1 *	5260.800	96.09			98.35	-2.26 Average							
2 *	5296.600	105.41			107.58	-2.17 Peak	2 *	5260.800	108.95			111.21	-2.26 Peak							
3 !	5352.200	52.47	54.00	-1.53	54.49	-2.02 Average	3 !	5350.400	53.53	54.00	-0.47	55.56	-2.03 Average							
4 !	5352.200	69.41	74.00	-4.59	71.43	-2.02 Peak	4 !	5350.400	67.66	74.00	-6.34	69.69	-2.03 Peak							
1 !	10580.000	57.57	68.20	-10.63	50.41	7.16 Peak	1 !	10580.000	56.91	68.20	-11.29	49.75	7.16 Peak							
2 !	15870.000	40.43	54.00	-13.57	30.62	9.81 Average	2 !	15870.000	40.64	54.00	-13.36	30.83	9.81 Average							
3 !	15870.000	53.59	74.00	-20.41	43.78	9.81 Peak	3 !	15870.000	53.83	74.00	-20.17	44.02	9.81 Peak							

Above 1G (1 GHz-40 GHz) in UNII-2c:

802.11a mode:

Low CH															
Horizontal							Vertical								
Freq	Level	Limit Line	Over Limit	Read Level	Factor	Remark	Freq	Level	Limit Line	Over Limit	Read Level	Factor	Remark		
MHz	dBuV/m	dBuV/m	dB	dBuV	dB/m		MHz	dBuV/m	dBuV/m	dB	dBuV	dB/m			
1 !	5445.100	48.71	54.00	-5.29	50.46	-1.75	Average	1 !	5433.770	48.69	54.00	-5.31	50.48	-1.79	Average
2 !	5445.100	62.41	74.00	-11.59	64.16	-1.75	Peak	2 !	5433.770	62.21	74.00	-11.79	64.00	-1.79	Peak
3 *	5497.460	97.53			99.15	-1.62	Average	3 *	5503.840	100.34			101.93	-1.59	Average
4 *	5497.460	108.14			109.76	-1.62	Peak	4 *	5503.840	109.26			110.85	-1.59	Peak
1 !	11000.000	47.34	54.00	-6.66	39.60	7.74	Average	1 !	11000.000	52.64	54.00	-1.36	44.90	7.74	Average
2 !	11000.000	60.47	74.00	-13.53	52.73	7.74	Peak	2 !	11000.000	65.64	74.00	-8.36	57.90	7.74	Peak
3 !	16500.000	54.39	68.20	-13.81	43.21	11.18	Peak	3 !	16500.000	53.16	68.20	-15.04	41.98	11.18	Peak

Middle CH															
Horizontal							Vertical								
Freq	Level	Limit Line	Over Limit	Read Level	Factor	Remark	Freq	Level	Limit Line	Over Limit	Read Level	Factor	Remark		
MHz	dBuV/m	dBuV/m	dB	dBuV	dB/m		MHz	dBuV/m	dBuV/m	dB	dBuV	dB/m			
1 !	5404.940	48.23	54.00	-5.77	50.10	-1.87	Average	1 !	5446.740	48.65	54.00	-5.35	50.40	-1.75	Average
2 !	5404.940	61.21	74.00	-12.79	63.08	-1.87	Peak	2 !	5446.740	61.76	74.00	-12.24	63.51	-1.75	Peak
3 *	5577.460	98.00			99.31	-1.31	Average	3 *	5581.640	99.45			100.75	-1.30	Average
4 *	5577.460	108.35			109.66	-1.31	Peak	4 *	5581.640	108.20			109.50	-1.30	Peak
5 !	5752.260	62.99	68.20	-5.21	63.60	-0.61	Peak	5 !	5751.880	62.97	68.20	-5.23	63.58	-0.61	Peak
1 !	11160.000	48.01	54.00	-5.99	40.46	7.55	Average	1 !	11160.000	52.35	54.00	-1.65	44.80	7.55	Average
2 !	11160.000	62.07	74.00	-11.93	54.52	7.55	Peak	2 !	11160.000	65.80	74.00	-8.20	58.25	7.55	Peak
3 !	16756.000	55.15	68.20	-13.05	42.67	12.48	Peak	3 !	16740.000	55.60	68.20	-12.60	43.22	12.38	Peak

High CH															
Horizontal							Vertical								
Freq	Level	Limit Line	Over Limit	Read Level	Factor	Remark	Freq	Level	Limit Line	Over Limit	Read Level	Factor	Remark		
MHz	dBuV/m	dBuV/m	dB	dBuV	dB/m		MHz	dBuV/m	dBuV/m	dB	dBuV	dB/m			
1 *	5697.370	97.80			98.64	-0.84	Average	1 *	5702.430	100.83			101.64	-0.81	Average
2 *	5697.370	108.23			109.07	-0.84	Peak	2 *	5702.430	110.36			111.17	-0.81	Peak
3 !	5781.410	64.69	68.20	-3.51	65.18	-0.49	Peak	3 !	5797.360	64.77	68.20	-3.43	65.20	-0.43	Peak
1 !	11400.000	49.04	54.00	-4.96	41.66	7.38	Average	1 !	11400.000	52.48	54.00	-1.52	45.10	7.38	Average
2 !	11400.000	62.36	74.00	-11.64	54.98	7.38	Peak	2 !	11400.000	65.34	74.00	-8.66	57.96	7.38	Peak
3 !	17100.000	57.39	68.20	-10.81	43.11	14.28	Peak	3 !	17100.000	55.97	68.20	-12.23	41.69	14.28	Peak

802.11ax HE20 mode:

5500 MHz CH													
Horizontal							Vertical						
Freq	Level	Limit	Over	Read			Freq	Level	Limit	Over	Read		
		Line	Limit	Level	Factor	Remark			Line	Limit	Level	Factor	Remark
MHz	dBuV/m	dBuV/m	dB	dBuV	dB/m		MHz	dBuV/m	dBuV/m	dB	dBuV	dB/m	
1 !	5458.190	48.71	54.00	-5.29	50.43	-1.72 Average	1 !	5455.550	48.95	54.00	-5.05	50.68	-1.73 Average
2 !	5458.190	62.35	74.00	-11.65	64.07	-1.72 Peak	2 !	5455.550	62.30	74.00	-11.70	64.03	-1.73 Peak
3 *	5494.490	96.48			98.10	-1.62 Average	3 *	5495.700	99.58			101.20	-1.62 Average
4 *	5494.490	108.60			110.22	-1.62 Peak	4 *	5495.700	112.74			114.36	-1.62 Peak
1 !	11100.000	49.04	54.00	-4.96	41.30	7.74 Average	1 !	11100.000	52.99	54.00	-1.01	45.25	7.74 Average
2 !	11100.000	62.61	74.00	-11.39	54.87	7.74 Peak	2 !	11100.000	66.25	74.00	-7.75	58.51	7.74 Peak
3 !	16500.000	53.56	68.20	-14.64	42.38	11.18 Peak	3 !	16500.000	53.29	68.20	-14.91	42.11	11.18 Peak

5580 MHz CH													
Horizontal							Vertical						
Freq	Level	Limit	Over	Read			Freq	Level	Limit	Over	Read		
		Line	Limit	Level	Factor	Remark			Line	Limit	Level	Factor	Remark
MHz	dBuV/m	dBuV/m	dB	dBuV	dB/m		MHz	dBuV/m	dBuV/m	dB	dBuV	dB/m	
1 !	5436.100	48.95	54.00	-5.05	50.73	-1.78 Average	1 !	5417.860	48.27	54.00	-5.73	50.10	-1.83 Average
2 !	5436.100	61.37	74.00	-12.63	63.15	-1.78 Peak	2 !	5417.860	61.84	74.00	-12.16	63.67	-1.83 Peak
3 *	5584.680	98.36			99.65	-1.29 Average	3 *	5585.440	100.27			101.55	-1.28 Average
4 *	5584.680	110.70			111.99	-1.29 Peak	4 *	5585.440	112.26			113.54	-1.28 Peak
5 !	5746.180	62.60	68.20	-5.60	63.24	-0.64 Peak	5 !	5756.440	63.21	68.20	-4.99	63.80	-0.59 Peak
1 !	11160.000	50.46	54.00	-3.54	42.91	7.55 Average	1 !	11160.000	53.91	54.00	-0.09	46.36	7.55 Average
2 !	11160.000	64.50	74.00	-9.50	56.95	7.55 Peak	2 !	11160.000	67.43	74.00	-6.57	59.88	7.55 Peak
3 !	16740.000	55.46	68.20	-12.74	43.08	12.38 Peak	3 !	16740.000	55.34	68.20	-12.86	42.96	12.38 Peak

5700 MHz CH													
Horizontal							Vertical						
Freq	Level	Limit	Over	Read			Freq	Level	Limit	Over	Read		
		Line	Limit	Level	Factor	Remark			Line	Limit	Level	Factor	Remark
MHz	dBuV/m	dBuV/m	dB	dBuV	dB/m		MHz	dBuV/m	dBuV/m	dB	dBuV	dB/m	
1 *	5704.300	97.39			98.20	-0.81 Average	1 *	5695.720	100.79			101.63	-0.84 Average
2 *	5704.300	109.72			110.53	-0.81 Peak	2 *	5695.720	114.26			115.10	-0.84 Peak
3 !	5792.080	64.23	68.20	-3.97	64.68	-0.45 Peak	3 !	5747.750	65.23	68.20	-2.97	65.87	-0.64 Peak
1 !	111400.000	52.84	54.00	-1.16	45.46	7.38 Average	1 !	111400.000	50.79	54.00	-3.21	43.41	7.38 Average
2 !	111400.000	62.89	74.00	-11.11	55.51	7.38 Peak	2 !	111400.000	63.17	74.00	-10.83	55.79	7.38 Peak
3 !	17100.000	57.85	68.20	-10.35	43.57	14.28 Peak	3 !	17100.000	56.78	68.20	-11.42	42.50	14.28 Peak

5720 MHz CH															
Horizontal							Vertical								
Limit	Over	Read					Limit	Over	Read						
Line	Limit	Level	Factor	Remark			Line	Limit	Level	Factor	Remark				
Freq	Level	Line	Limit	Level	Factor	Remark	Freq	Level	Line	Limit	Level	Factor	Remark		
MHz	dBuV/m	dBuV/m	dB	dBuV	dB/m		MHz	dBuV/m	dBuV/m	dB	dBuV	dB/m			
1 !	5406.820	48.40	54.00	-5.60	50.26	-1.86	Average	1 !	5436.580	48.67	54.00	-5.33	50.45	-1.78	Average
2 !	5406.820	61.13	74.00	-12.87	62.99	-1.86	Peak	2 !	5436.580	62.59	74.00	-11.41	64.37	-1.78	Peak
3 *	5729.220	97.30			98.01	-0.71	Average	3 *	5725.500	100.55			101.27	-0.72	Average
4 *	5729.220	109.16			109.87	-0.71	Peak	4 *	5725.500	111.89			112.61	-0.72	Peak
5 !	5990.240	64.97	68.20	-3.23	64.58	0.39	Peak	5 !	5860.040	64.99	68.20	-3.21	65.16	-0.17	Peak
1 !	11440.000	49.00	54.00	-5.00	41.65	7.35	Average	1 !	11440.000	52.83	54.00	-1.17	45.48	7.35	Average
2 !	11440.000	60.97	74.00	-13.03	53.62	7.35	Peak	2 !	11440.000	64.69	74.00	-9.31	57.34	7.35	Peak
3 !	17160.000	58.29	68.20	-9.91	43.70	14.59	Peak	3 !	17160.000	57.04	68.20	-11.16	42.45	14.59	Peak

802.11ax HE40 mode:

5510 MHz CH															
Horizontal							Vertical								
Limit	Over	Read					Limit	Over	Read						
Line	Limit	Level	Factor	Remark			Line	Limit	Level	Factor	Remark				
Freq	Level	Line	Limit	Level	Factor	Remark	Freq	Level	Line	Limit	Level	Factor	Remark		
MHz	dBuV/m	dBuV/m	dB	dBuV	dB/m		MHz	dBuV/m	dBuV/m	dB	dBuV	dB/m			
1 !	5455.380	48.73	54.00	-5.27	50.46	-1.73	Average	1 !	5435.620	49.53	54.00	-4.47	51.31	-1.78	Average
2 !	5455.380	63.14	74.00	-10.86	64.87	-1.73	Peak	2 !	5435.620	63.07	74.00	-10.93	64.85	-1.78	Peak
3 *	5517.520	96.13			97.66	-1.53	Average	3 *	5525.970	100.00			101.50	-1.50	Average
4 *	5517.520	109.18			110.71	-1.53	Peak	4 *	5525.970	111.59			113.09	-1.50	Peak
1 !	11020.000	51.58	54.00	-2.42	43.86	7.72	Average	1 !	11020.000	53.09	54.00	-0.91	45.37	7.72	Average
2 !	11020.000	62.22	74.00	-11.78	54.50	7.72	Peak	2 !	11020.000	66.32	74.00	-7.68	58.60	7.72	Peak
3 !	16530.000	55.95	68.20	-12.25	44.61	11.34	Peak	3 !	16530.000	54.10	68.20	-14.10	42.76	11.34	Peak

5550 MHz CH															
Horizontal							Vertical								
Limit	Over	Read					Limit	Over	Read						
Line	Limit	Level	Factor	Remark			Line	Limit	Level	Factor	Remark				
Freq	Level	Line	Limit	Level	Factor	Remark	Freq	Level	Line	Limit	Level	Factor	Remark		
MHz	dBuV/m	dBuV/m	dB	dBuV	dB/m		MHz	dBuV/m	dBuV/m	dB	dBuV	dB/m			
1 !	5450.540	48.66	54.00	-5.34	50.40	-1.74	Average	1 !	5454.340	48.92	54.00	-5.08	50.65	-1.73	Average
2 !	5450.540	61.81	74.00	-12.19	63.55	-1.74	Peak	2 !	5454.340	62.55	74.00	-11.45	64.28	-1.73	Peak
3 *	5542.500	96.69			98.13	-1.44	Average	3 *	5566.060	99.40			100.76	-1.36	Average
4 *	5542.500	109.16			110.60	-1.44	Peak	4 *	5566.060	110.79			112.15	-1.36	Peak
5 !	5757.960	63.96	68.20	-4.24	64.54	-0.58	Peak	5 !	5754.920	64.11	68.20	-4.09	64.71	-0.60	Peak
1 !	11100.000	48.72	54.00	-5.28	41.09	7.63	Average	1 !	11100.000	53.12	54.00	-0.88	45.49	7.63	Average
2 !	11100.000	62.47	74.00	-11.53	54.84	7.63	Peak	2 !	11100.000	66.27	74.00	-7.73	58.64	7.63	Peak
3 !	16650.000	56.03	68.20	-12.17	44.00	12.03	Peak	3 !	16650.000	55.18	68.20	-13.02	43.15	12.03	Peak

5670 MHz CH																	
Horizontal							Vertical										
Freq		Level	Limit Line	Over Limit	Read Level	Factor	Remark	Freq		Level	Limit Line	Over Limit	Read Level	Factor	Remark		
MHz	dBuV/m	dBuV/m	dB	dBuV	dB/m			MHz	dBuV/m	dBuV/m	dB	dBuV	dB/m				
1	*	5669.350	97.01		97.96	-0.95	Average	1	*	5685.850	99.96		100.85	-0.89	Average		
2	*	5669.350	108.75		109.70	-0.95	Peak	2	*	5685.850	111.78		112.67	-0.89	Peak		
3	!	5783.650	63.96	68.20	-4.24	64.44	-0.48	Peak	3	!	5766.400	64.74	68.20	-3.46	65.30	-0.56	Peak
1	!	111340.000	51.16	54.00	-2.84	43.75	7.41	Average	1	!	111340.000	52.86	54.00	-1.14	45.45	7.41	Average
2	!	111340.000	62.81	74.00	-11.19	55.40	7.41	Peak	2	!	111340.000	63.16	74.00	-10.84	55.75	7.41	Peak
3	!	117010.000	57.81	68.20	-10.39	43.89	13.92	Peak	3	!	117010.000	56.07	68.20	-12.13	42.15	13.92	Peak

5710 MHz CH																	
Horizontal							Vertical										
Freq		Level	Limit Line	Over Limit	Read Level	Factor	Remark	Freq		Level	Limit Line	Over Limit	Read Level	Factor	Remark		
MHz	dBuV/m	dBuV/m	dB	dBuV	dB/m			MHz	dBuV/m	dBuV/m	dB	dBuV	dB/m				
1	!	5440.920	48.49	54.00	-5.51	50.26	-1.77	Average	1	!	5454.560	48.63	54.00	-5.37	50.36	-1.73	Average
2	!	5440.920	61.14	74.00	-12.86	62.91	-1.77	Peak	2	!	5454.560	61.82	74.00	-12.18	63.55	-1.73	Peak
3	*	5709.380	97.08		97.87	-0.79	Average	3	*	5720.540	100.16		100.90	-0.74	Average		
4	*	5709.380	108.89		109.68	-0.79	Peak	4	*	5720.540	112.98		113.72	-0.74	Peak		
5	!	5940.640	63.44	68.20	-4.76	63.28	0.16	Peak	5	!	6000.780	64.55	68.20	-3.65	64.12	0.43	Peak
1	!	111420.000	50.13	54.00	-3.87	42.76	7.37	Average	1	!	111420.000	52.72	54.00	-1.28	45.35	7.37	Average
2	!	111420.000	62.59	74.00	-11.41	55.22	7.37	Peak	2	!	111420.000	64.77	74.00	-9.23	57.40	7.37	Peak
3	!	117130.000	59.02	68.20	-9.18	44.55	14.47	Peak	3	!	117130.000	56.42	68.20	-11.78	41.95	14.47	Peak

802.11ax HE80 mode:

5530 MHz CH													
Horizontal							Vertical						
Freq	Level	Limit Line	Over Limit	Read Level	Factor	Remark	Freq	Level	Limit Line	Over Limit	Read Level	Factor	Remark
MHz	dBuV/m	dBuV/m	dB	dBuV	dB/m		MHz	dBuV/m	dBuV/m	dB	dBuV	dB/m	
1 !	5456.950	51.30	54.00	-2.70	53.02	-1.72 Average	1 !	5450.830	52.30	54.00	-1.70	54.04	-1.74 Average
2 !	5456.950	64.37	74.00	-9.63	66.09	-1.72 Peak	2 !	5450.830	64.67	74.00	-9.33	66.41	-1.74 Peak
3 !	5465.620	66.27	68.20	-1.93	67.97	-1.70 Peak	3 !	5465.620	67.39	68.20	-0.81	69.09	-1.70 Peak
4 *	5546.370	94.32			95.75	-1.43 Average	4 *	5520.360	97.58			99.10	-1.52 Average
5 *	5546.370	106.96			108.39	-1.43 Peak	5 *	5520.360	109.84			111.36	-1.52 Peak
1 !	11060.000	49.67	54.00	-4.33	41.99	7.68 Average	1 !	11060.000	52.18	54.00	-1.82	44.50	7.68 Average
2 !	11060.000	65.20	74.00	-8.80	57.52	7.68 Peak	2 !	11060.000	66.68	74.00	-7.32	59.00	7.68 Peak
3 !	116590.000	56.99	68.20	-11.21	45.29	11.70 Peak	3 !	116590.000	54.53	68.20	-13.67	42.83	11.70 Peak

5610 MHz CH													
Horizontal							Vertical						
Freq	Level	Limit Line	Over Limit	Read Level	Factor	Remark	Freq	Level	Limit Line	Over Limit	Read Level	Factor	Remark
MHz	dBuV/m	dBuV/m	dB	dBuV	dB/m		MHz	dBuV/m	dBuV/m	dB	dBuV	dB/m	
1 !	5455.860	49.17	54.00	-4.83	50.90	-1.73 Average	1 !	5445.220	49.13	54.00	-4.87	50.88	-1.75 Average
2 !	5455.860	62.92	74.00	-11.08	64.65	-1.73 Peak	2 !	5445.220	62.15	74.00	-11.85	63.90	-1.75 Peak
3 *	5609.000	96.59			97.77	-1.18 Average	3 *	5600.640	99.10			100.32	-1.22 Average
4 *	5609.000	107.94			109.12	-1.18 Peak	4 *	5600.640	111.79			113.01	-1.22 Peak
5 !	5770.880	63.65	68.20	-4.55	64.18	-0.53 Peak	5 !	5767.080	64.67	68.20	-3.53	65.23	-0.56 Peak
1 !	11220.000	50.35	54.00	-3.65	42.85	7.50 Average	1 !	11220.000	52.50	54.00	-1.50	45.00	7.50 Average
2 !	11220.000	66.48	74.00	-7.52	58.98	7.50 Peak	2 !	11220.000	66.10	74.00	-7.90	58.60	7.50 Peak
3 !	116830.000	61.41	68.20	-6.79	48.52	12.89 Peak	3 !	116830.000	56.39	68.20	-11.81	43.50	12.89 Peak

5690 MHz CH													
Horizontal							Vertical						
Freq	Level	Limit Line	Over Limit	Read Level	Factor	Remark	Freq	Level	Limit Line	Over Limit	Read Level	Factor	Remark
MHz	dBuV/m	dBuV/m	dB	dBuV	dB/m		MHz	dBuV/m	dBuV/m	dB	dBuV	dB/m	
1 !	5400.620	48.56	54.00	-5.44	50.44	-1.88 Average	1 !	5445.880	48.69	54.00	-5.31	50.44	-1.75 Average
2 !	5400.620	62.06	74.00	-11.94	63.94	-1.88 Peak	2 !	5445.880	62.28	74.00	-11.72	64.03	-1.75 Peak
3 *	5694.500	96.28			97.13	-0.85 Average	3 *	5680.860	99.62			100.52	-0.90 Average
4 *	5694.500	108.44			109.29	-0.85 Peak	4 *	5680.860	113.05			113.95	-0.90 Peak
5 !	5973.500	64.77	68.20	-3.43	64.46	0.31 Peak	5 !	5863.140	64.30	68.20	-3.90	64.46	-0.16 Peak
1 !	111380.000	52.69	54.00	-1.31	45.29	7.40 Average	1 !	111380.000	48.70	54.00	-5.30	41.30	7.40 Average
2 !	111380.000	63.71	74.00	-10.29	56.31	7.40 Peak	2 !	111380.000	62.09	74.00	-11.91	54.69	7.40 Peak
3 !	117070.000	61.00	68.20	-7.20	46.87	14.13 Peak	3 !	117070.000	57.09	68.20	-11.11	42.96	14.13 Peak

Above 1G (1 GHz-40 GHz): test the worst mode: IEEE 802.11ax HE20 5580 MHz

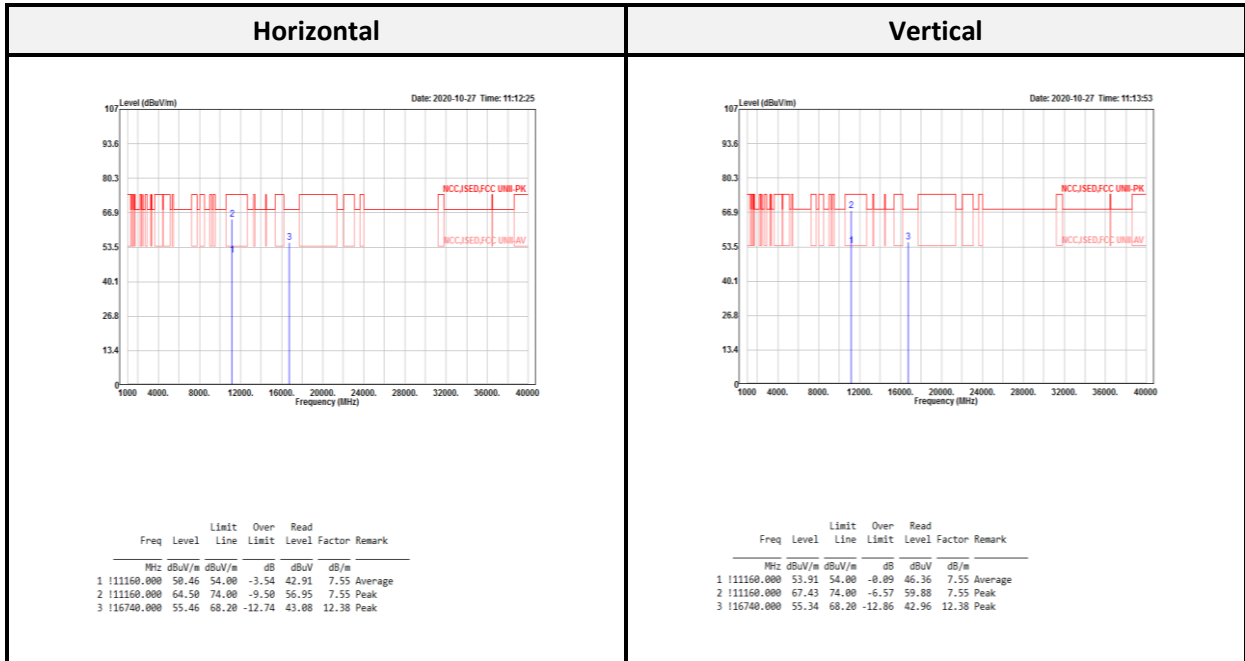

Level = Read Level + Factor

Over Limit = Level – Limit

Correct Factor = Antenna Factor + Cable Loss – Amplifier Gain

Spurious emissions more than 20 dB below the limit were not reported

8 FCC §15.407(a)(e) –Emission Bandwidth and Occupied Bandwidth

8.1 Applicable Standard

According to FCC §15.407(a),

The maximum power spectral density is measured as a conducted emission by direct connection of a calibrated test instrument to the equipment under test. If the device cannot be connected directly, alternative techniques acceptable to the Commission may be used. Measurements in the 5.725-5.85 GHz band are made over a reference bandwidth of 500 kHz or the 26 dB emission bandwidth of the device, whichever is less.

Measurements in the 5.15-5.25 GHz, 5.25-5.35 GHz, and the 5.47-5.725 GHz bands are made over a bandwidth of 1 MHz or the 26 dB emission bandwidth of the device, whichever is less. A narrower resolution bandwidth can be used, provided that the measured power is integrated over the full reference bandwidth.

As per FCC §15.407(e): for equipment operating in the band 5725 – 5850 MHz, the minimum 6 dB bandwidth of U-NII devices shall be 500 kHz.

8.2 Test Procedure

According to KDB 789033 D02 General UNII Test Procedures New Rules v02r01,

Emission Bandwidth (EBW)

- a) Set RBW = approximately 1% of the emission bandwidth;
- b) Set the VBW > RBW;
- c) Detector = Peak;
- d) Trace mode = max hold;
- e) Measure the maximum width of the emission that is 26 dB down from the maximum of the emission. Compare this with the RBW setting of the analyzer. Readjust RBW and repeat measurement as needed until the RBW/EBW ratio is approximately 1%;

99% Occupied Bandwidth

The 99% occupied bandwidth is the frequency bandwidth such that, below its lower and above its upper frequency limits, the mean powers are each equal to 0.5 % of the total mean power of the given emission. Measurement of the 99% occupied bandwidth is *required* only as a condition for using the optional band-edge measurement techniques described in II.G.3.d). Measurements of 99% occupied bandwidth may also optionally be used in lieu of the EBW to define the minimum frequency range over which the spectrum is integrated when measuring maximum conducted output power as described in II.E. However, the EBW must be measured to determine bandwidth dependent limits on maximum conducted output power in accordance with 15.407(a).

The following procedure shall be used for measuring (99 %) power bandwidth:

1. Set center frequency to the nominal EUT channel center frequency.
2. Set span = 1.5 times to 5.0 times the OBW.
3. Set RBW = 1 % to 5 % of the OBW
4. Set VBW $\geq 3 \cdot$ RBW
5. Video averaging is not permitted. Where practical, a sample detection and single sweep mode shall be used. Otherwise, peak detection and max hold mode (until the trace stabilizes) shall be used.
6. Use the 99 % power bandwidth function of the instrument (if available).
7. If the instrument does not have a 99 % power bandwidth function, the trace data points are recovered and directly summed in power units. The recovered amplitude data points, beginning at the lowest frequency, are placed in a running sum until 0.5 % of the total is reached; that frequency is recorded as the lower frequency. The process is repeated until 99.5 % of the total is reached; that frequency is recorded as the upper frequency. The 99% occupied bandwidth is the difference between these two frequencies.

8.3 Test Equipment List and Details

Description	Manufacture	Model	Serial No.	Cal. Date.	Cal. Due.
Conducted Room					
Spectrum Analyzer	Rohde & Schwarz	FSV40-N	100406	2020/03/11	2021/03/10
Cable	MTJ	MT40S	620620-MT40S-100	Each use	-

***Statement of Traceability:** The testing equipment’s listed above have finished the calibration by Electronics Testing Center, Taiwan (ETC) or other laboratories which were accredited by TAF or equivalent organizations. The calibration result could be traceable to the International System of Units (SI).

8.4 Test Data and Test Plot

UNII-2a

Mode	Channel	Frequency (MHz)	26dB Emission Bandwidth (MHz)			
			Ant. 1	Ant. 2	Ant. 3	Ant. 4
802.11a	52	5260	21.62	21.62	21.80	21.51
	60	5300	21.68	21.74	21.51	21.51
	64	5320	21.62	21.97	21.62	21.68
802.11ax HE20	52	5260	21.68	21.74	21.74	21.86
	60	5300	21.68	21.68	21.74	21.91
	64	5320	21.91	21.62	21.86	21.80
802.11ax HE40	54	5270	40.12	40.00	40.12	40.00
	62	5310	40.00	39.88	40.12	40.46
802.11ax HE80	58	5290	82.32	81.39	81.62	81.16

UNII-2c

Mode	Channel	Frequency (MHz)	26dB Emission Bandwidth (MHz)				Result
			Ant. 1	Ant. 2	Ant. 3	Ant. 4	
802.11a	100	5500	21.97	21.68	21.80	21.57	Compliance
	116	5580	21.80	21.80	22.03	21.74	Compliance
	140	5700	21.74	21.57	21.86	21.68	Compliance
802.11ax HE20	100	5500	21.80	21.91	21.80	21.74	Compliance
	116	5580	22.03	21.86	21.74	21.74	Compliance
	140	5700	21.86	21.68	21.74	21.45	Compliance
	144	5720	16.30	16.34	16.23	16.44	Compliance
802.11ax HE40	102	5510	40.23	40.00	40.23	40.23	Compliance
	110	5550	40.12	39.77	40.12	40.35	Compliance
	134	5670	40.23	40.12	39.88	40.23	Compliance
	142	5710	35.22	35.00	35.22	35.22	Compliance
802.11ax HE80	106	5530	82.55	82.09	82.55	81.39	Compliance
	122	5610	83.01	80.93	81.39	81.62	Compliance
	138	5690	74.90	75.83	75.60	75.13	Compliance

For UNII-2a

802.11a mode

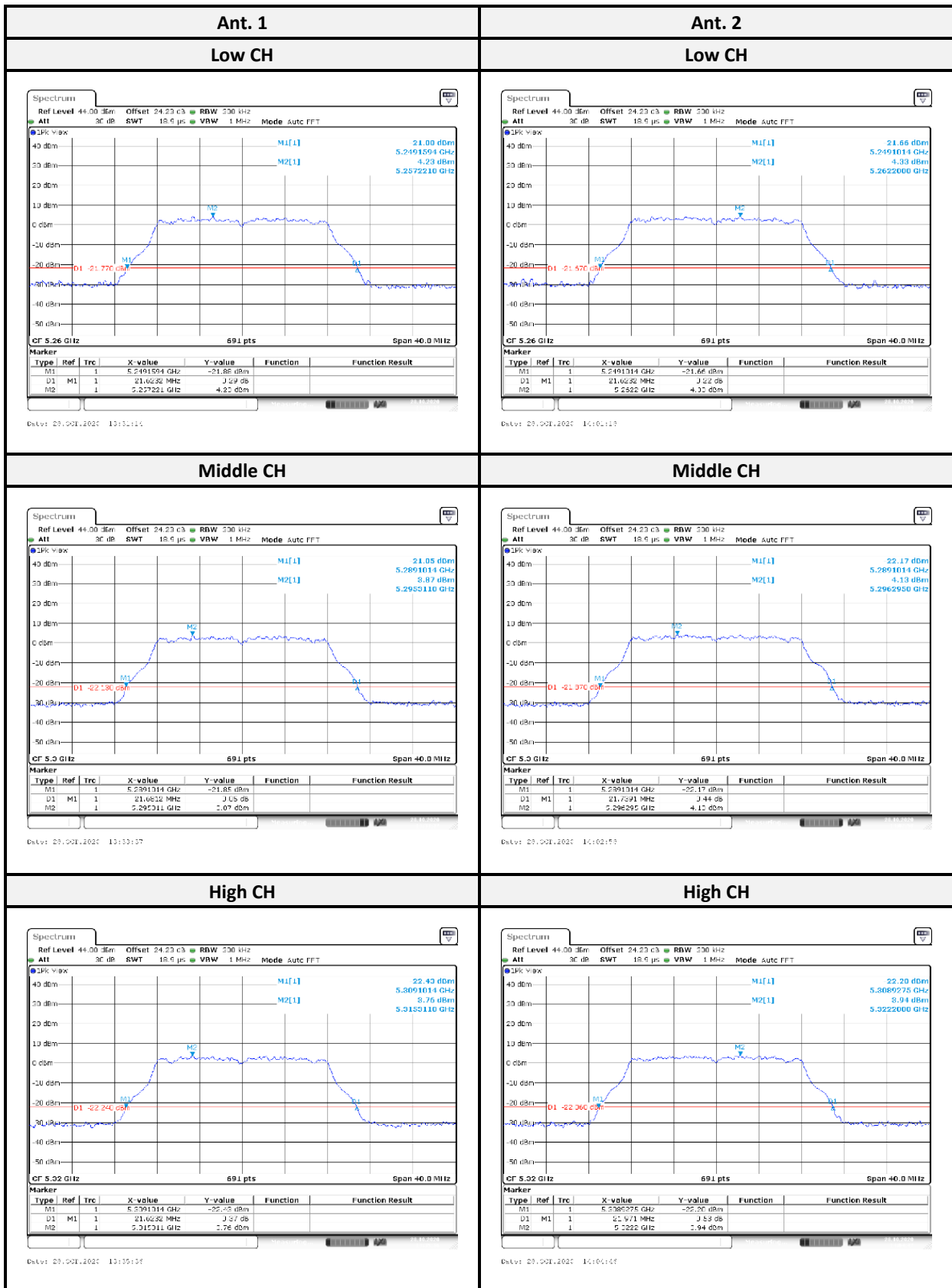

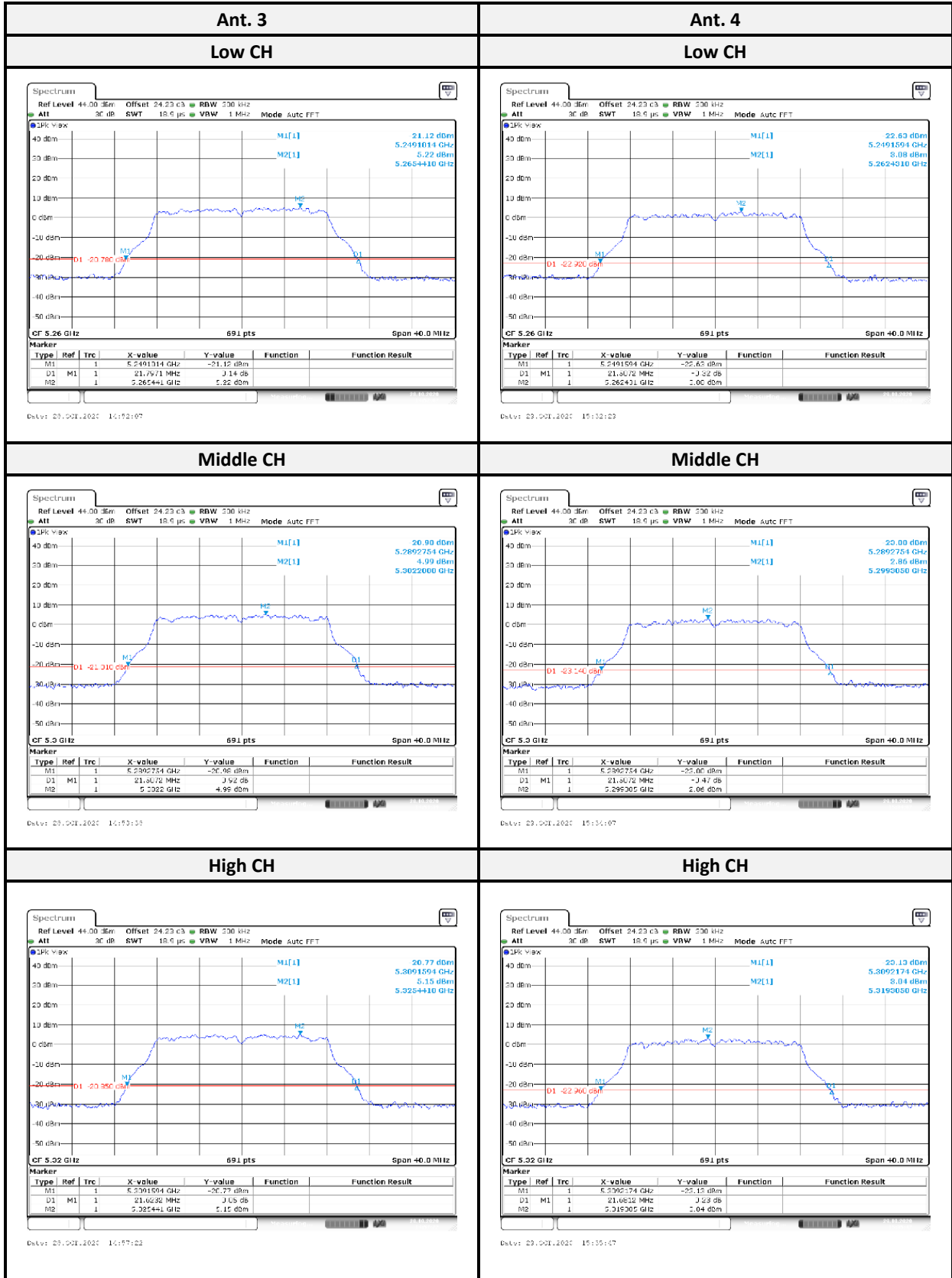

802.11ax HE20 mode:

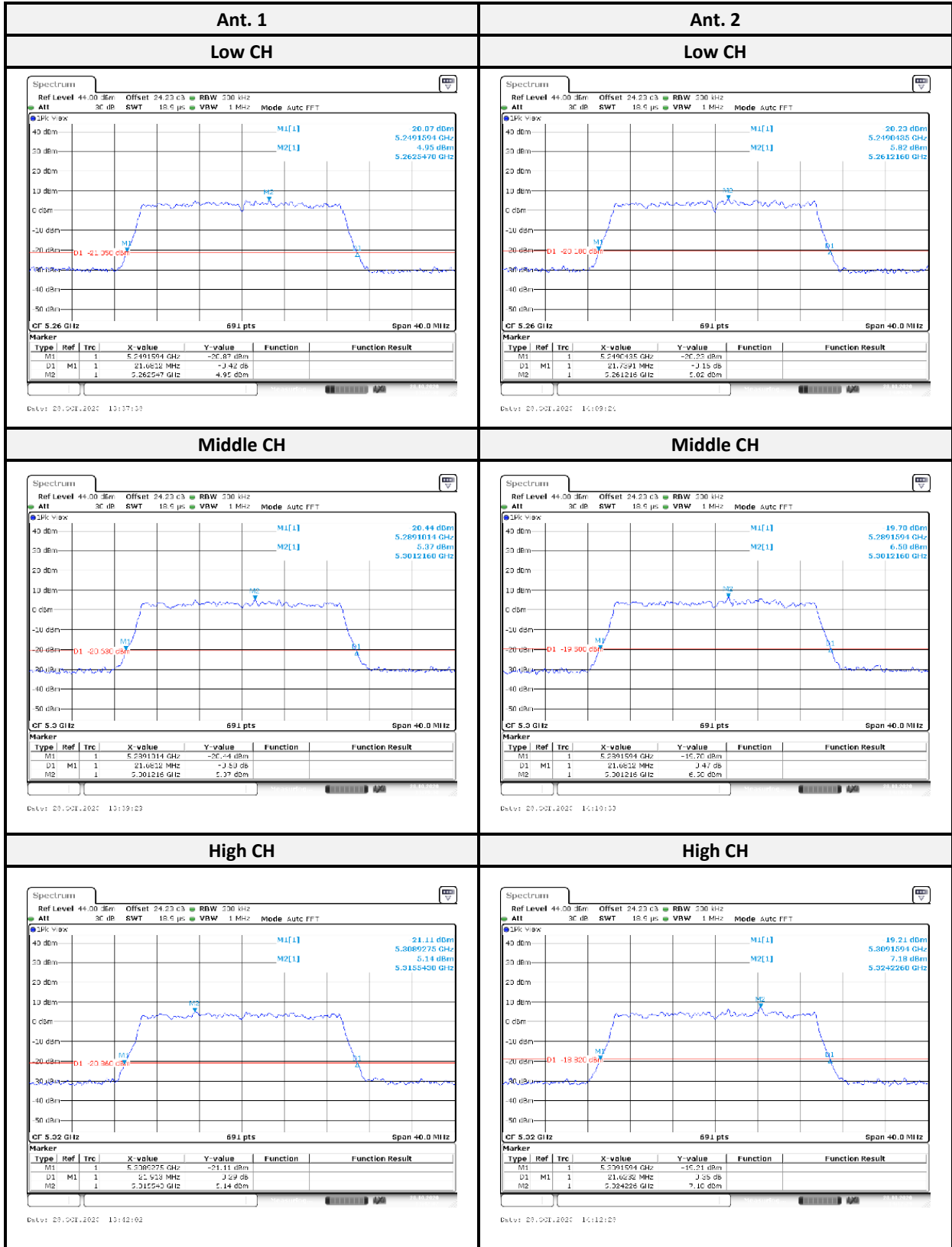

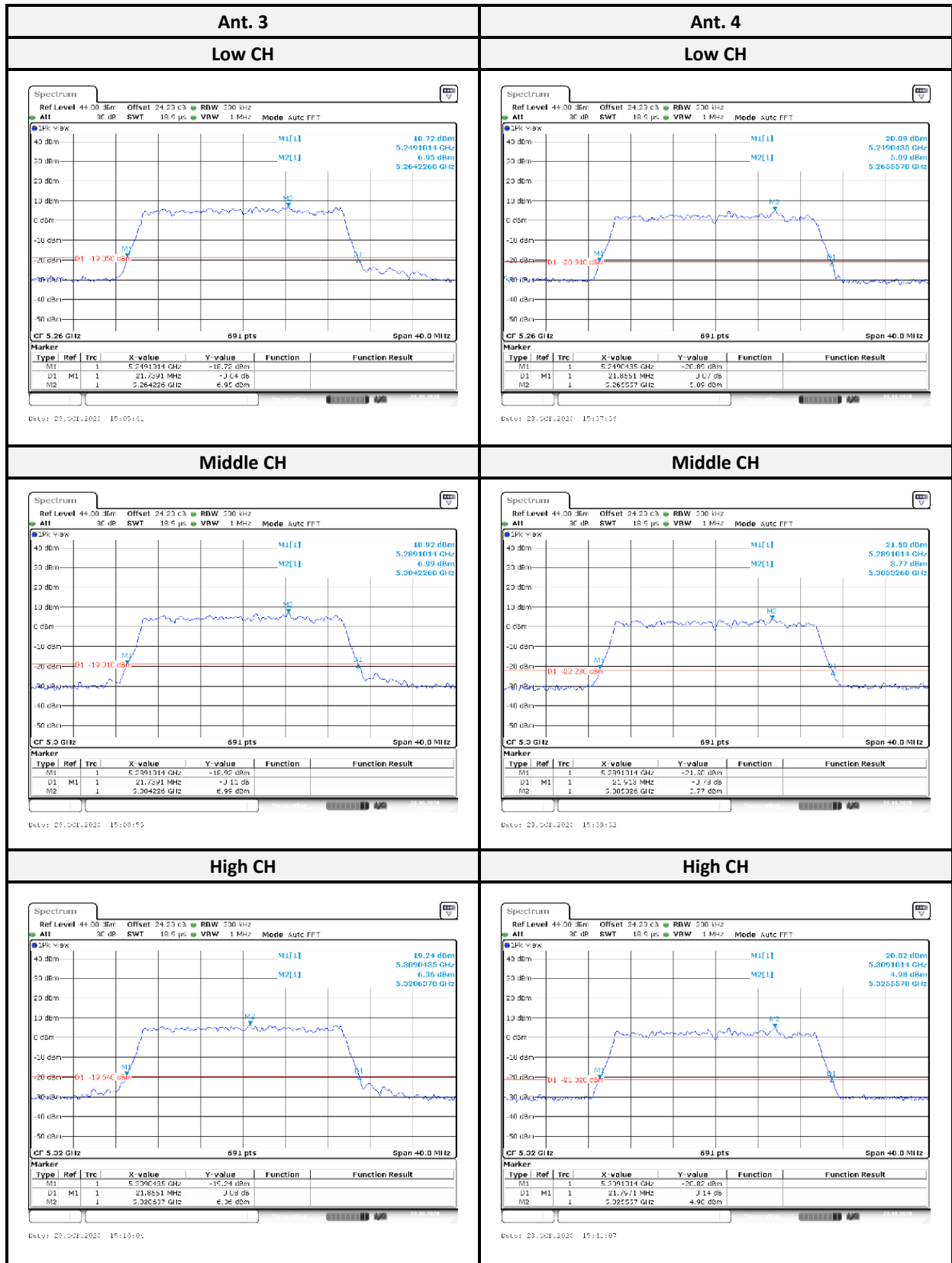

802.11ax HE40 mode:

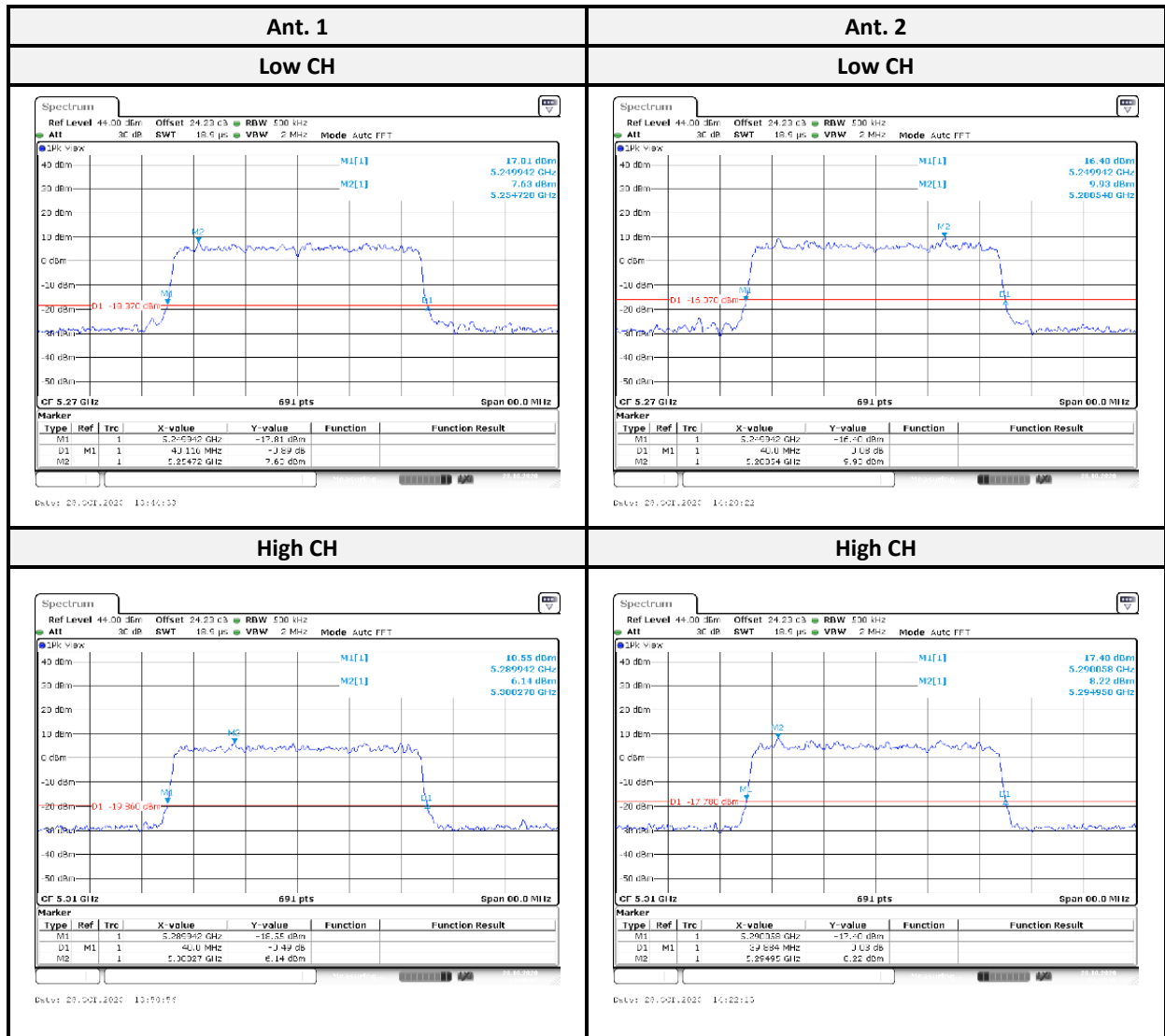

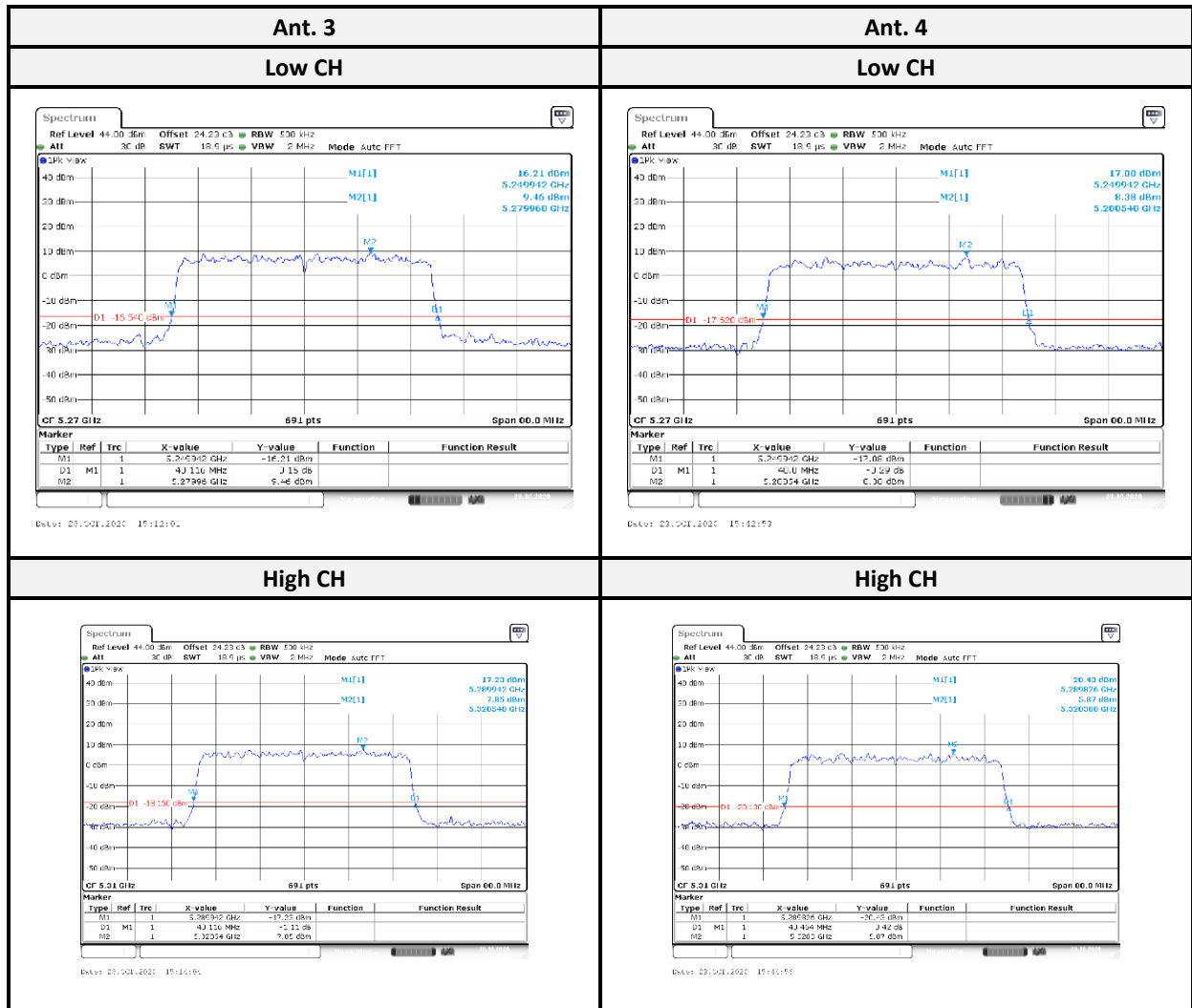

802.11ax HE80 mode:

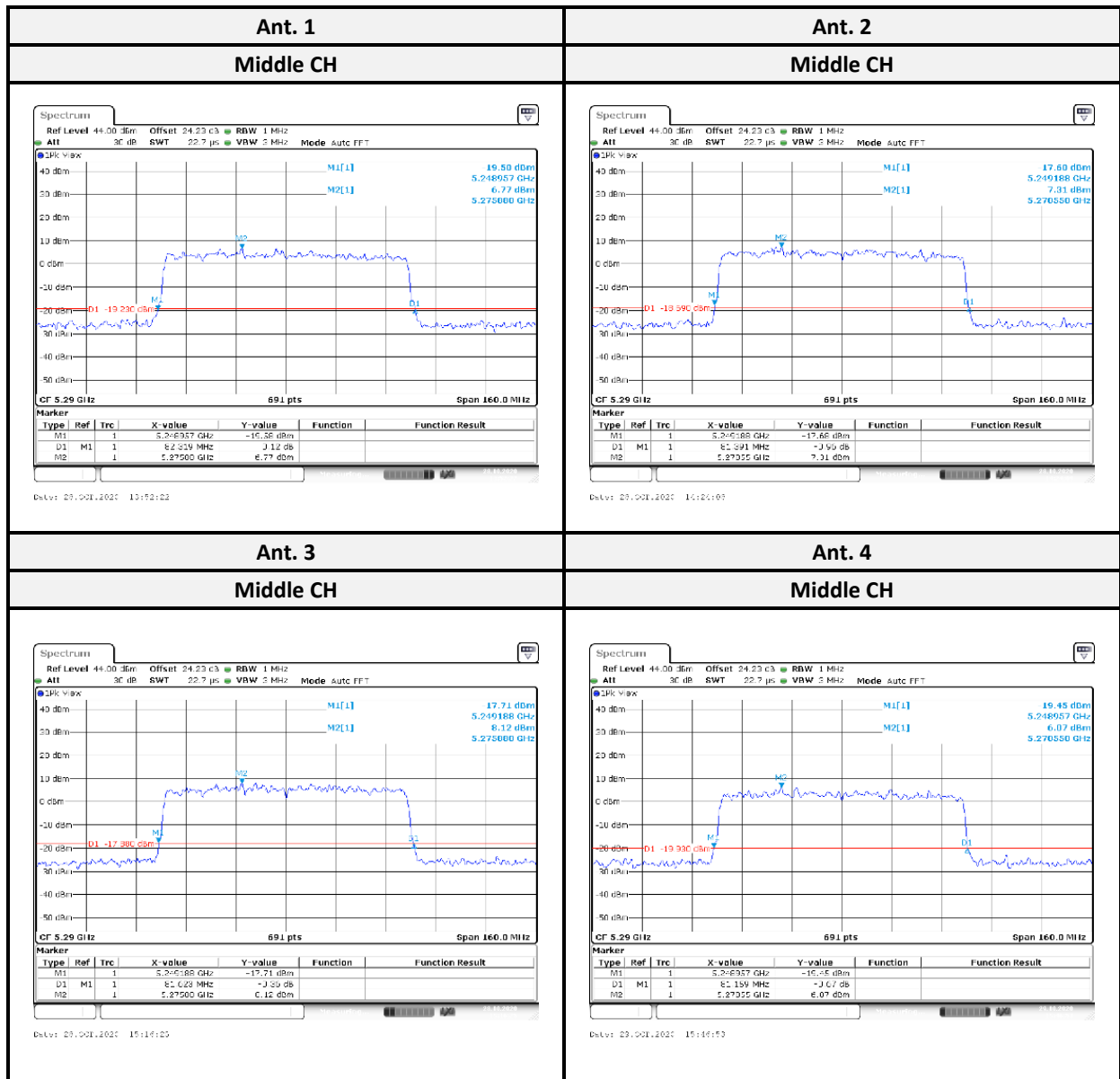

For UNII-2c

802.11a mode

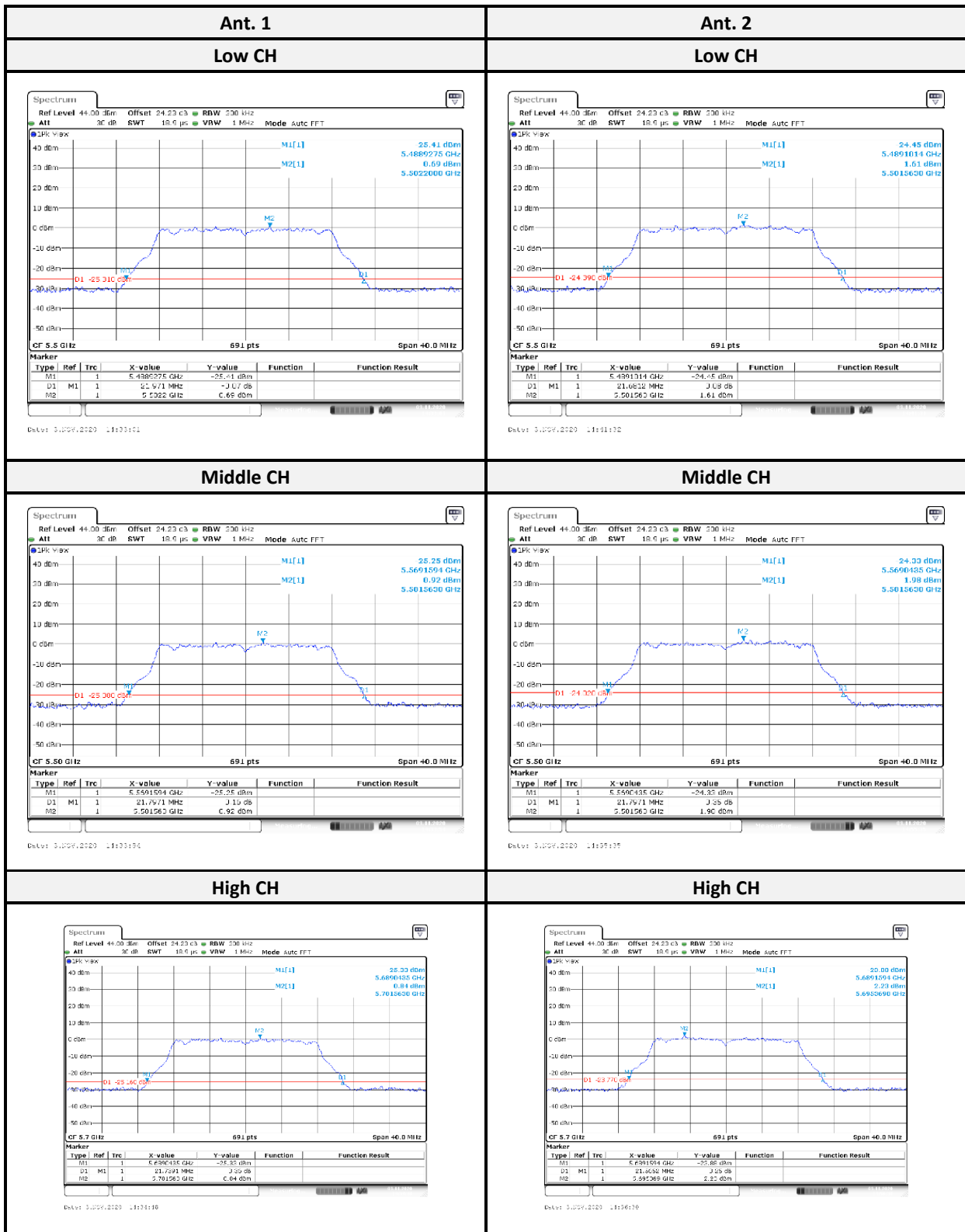

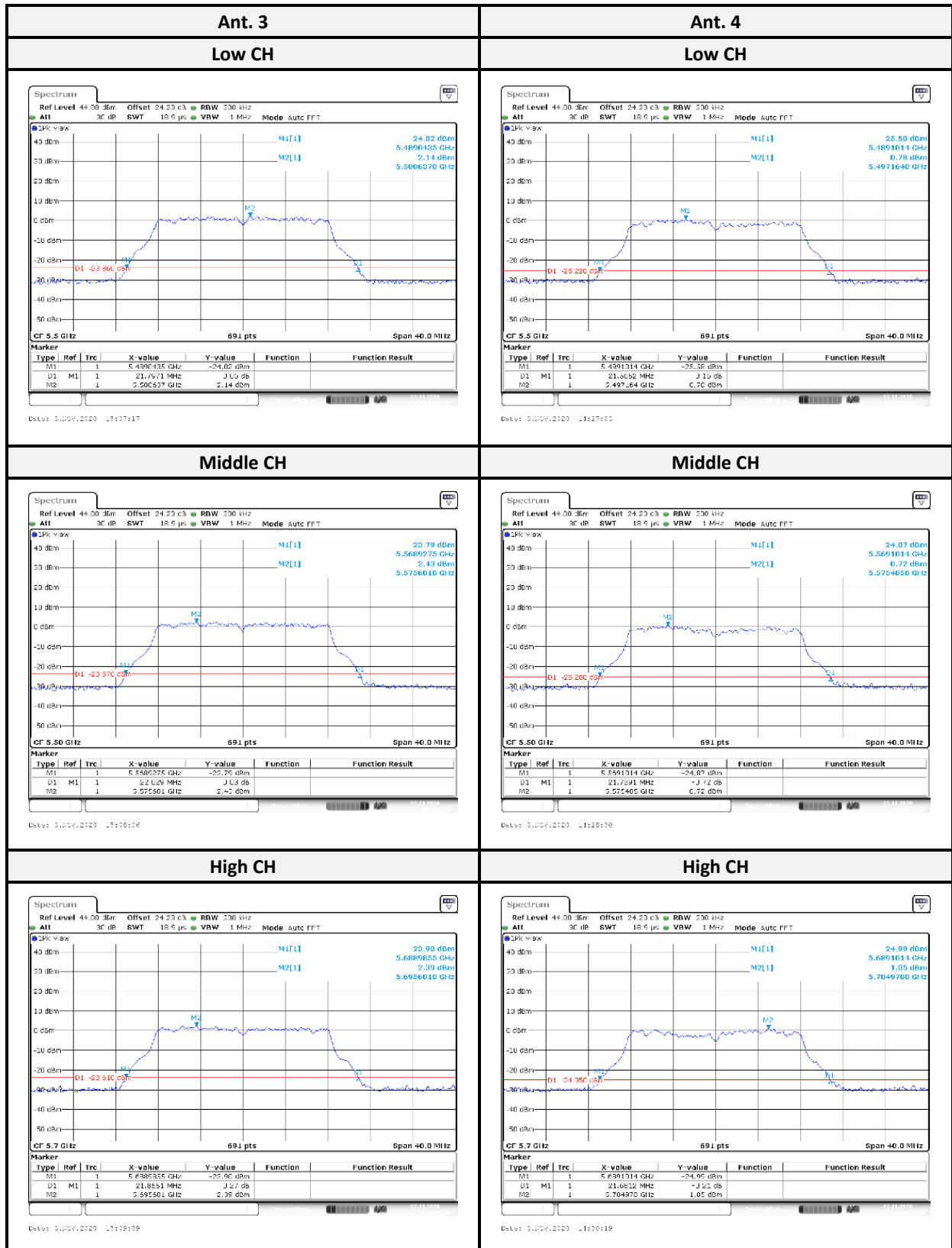

802.11ax HE20 mode:

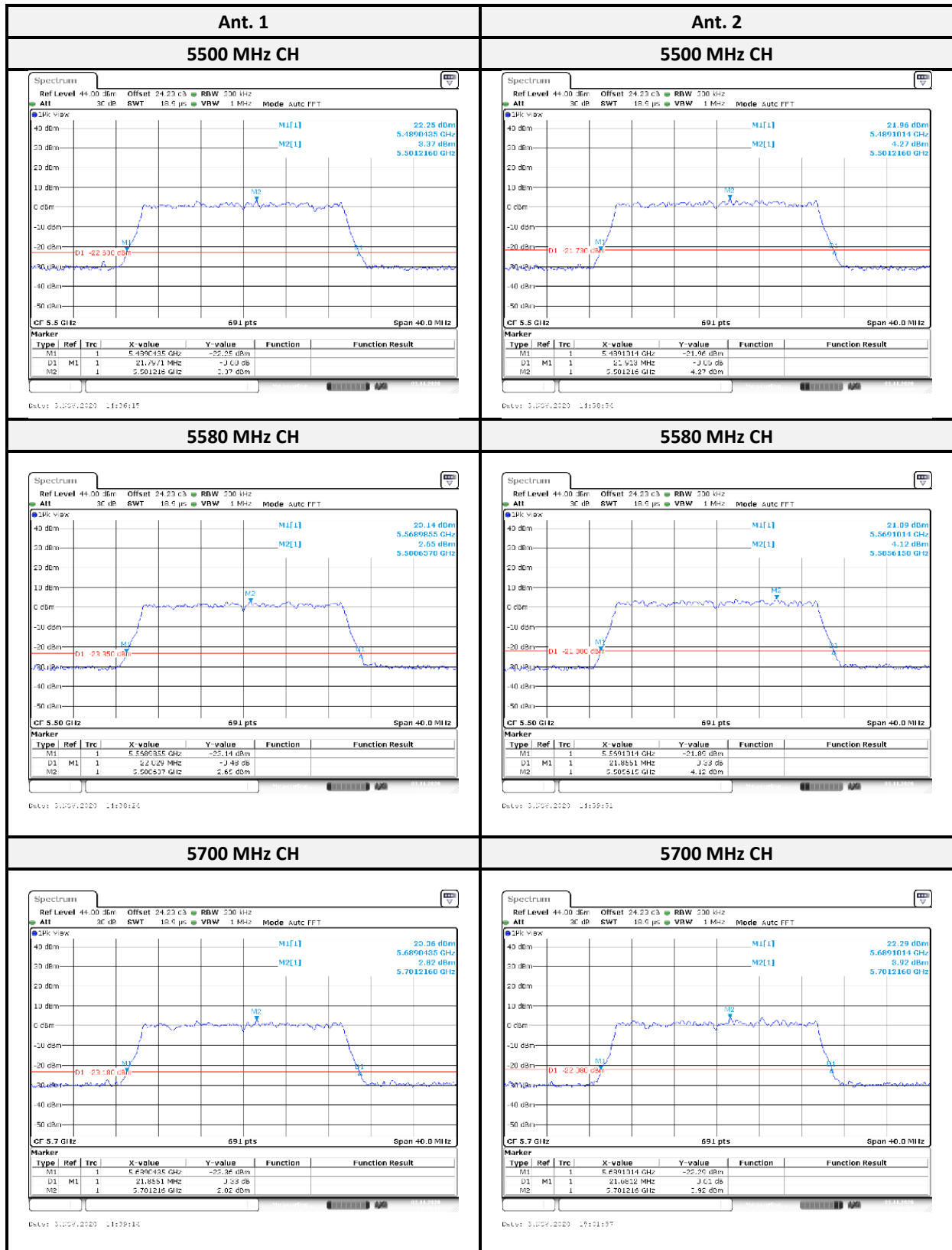

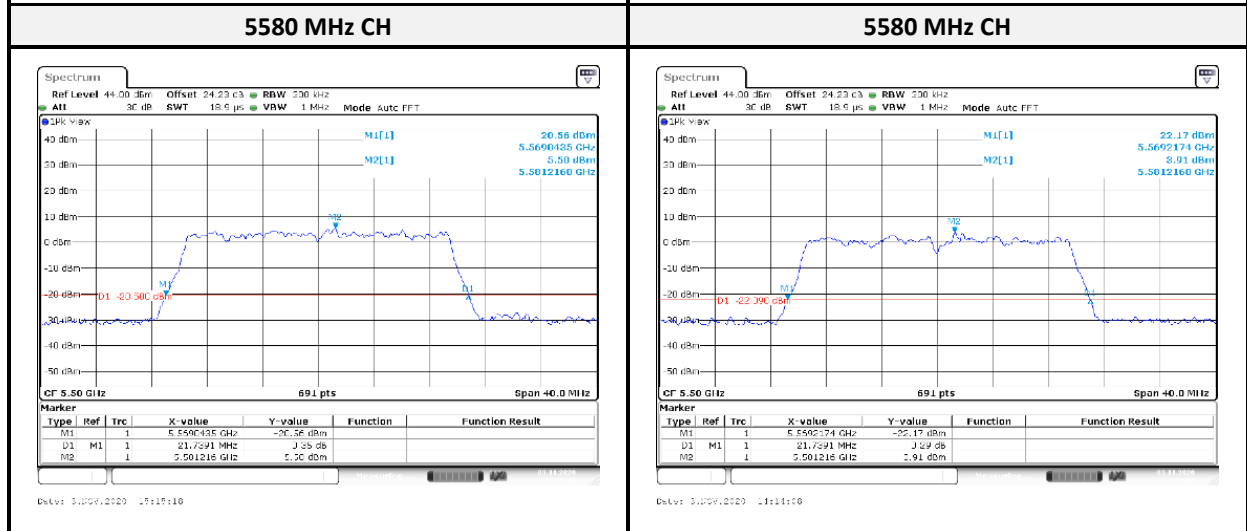
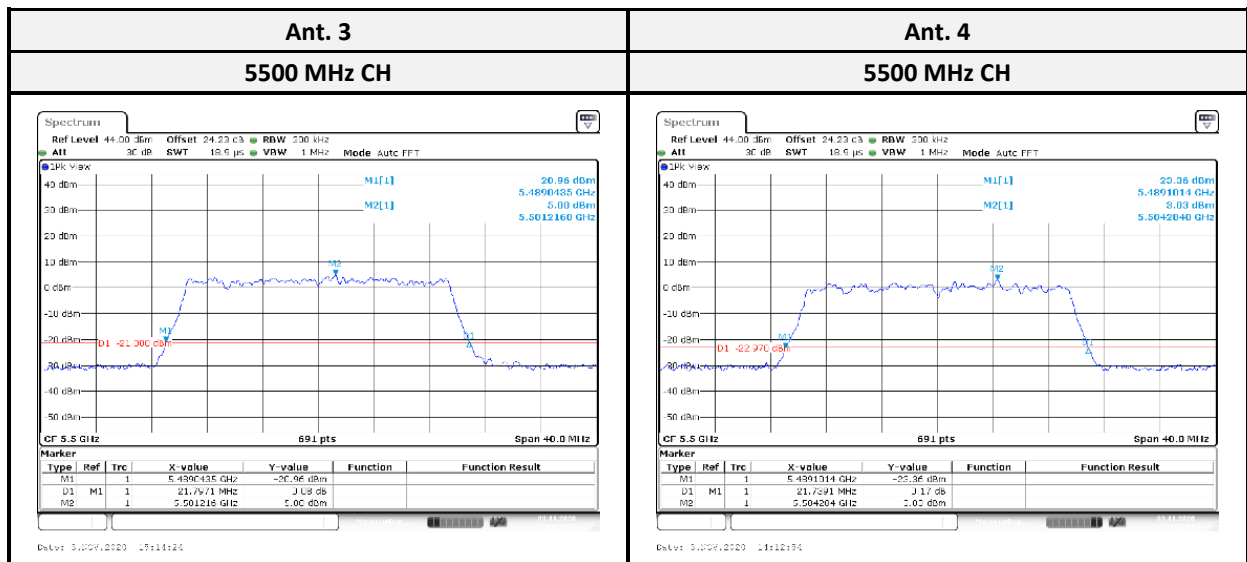
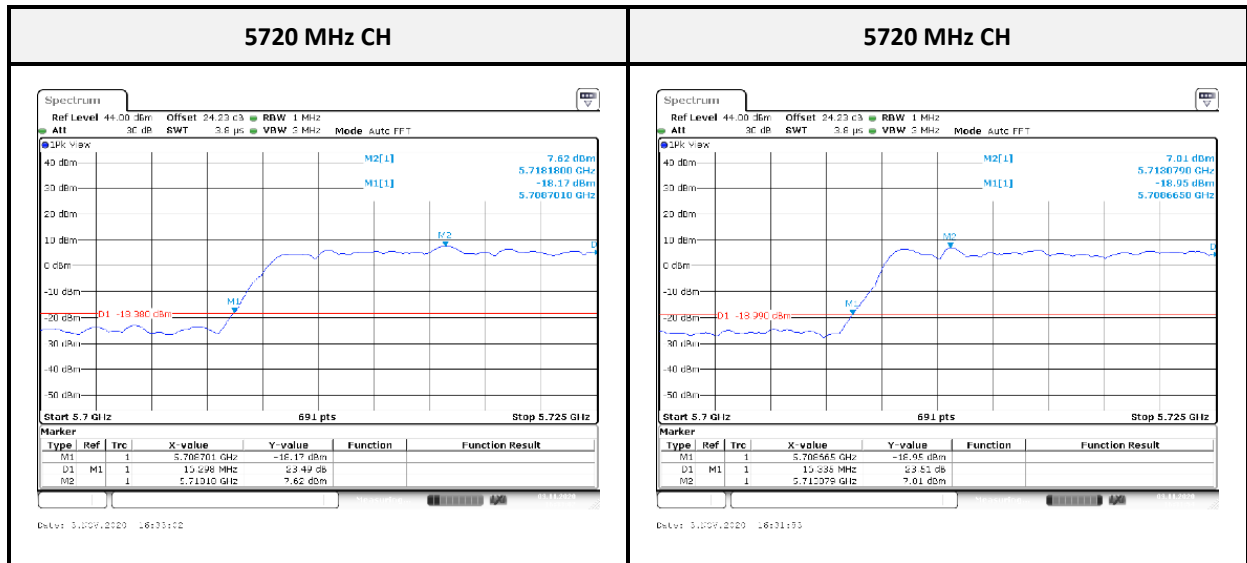

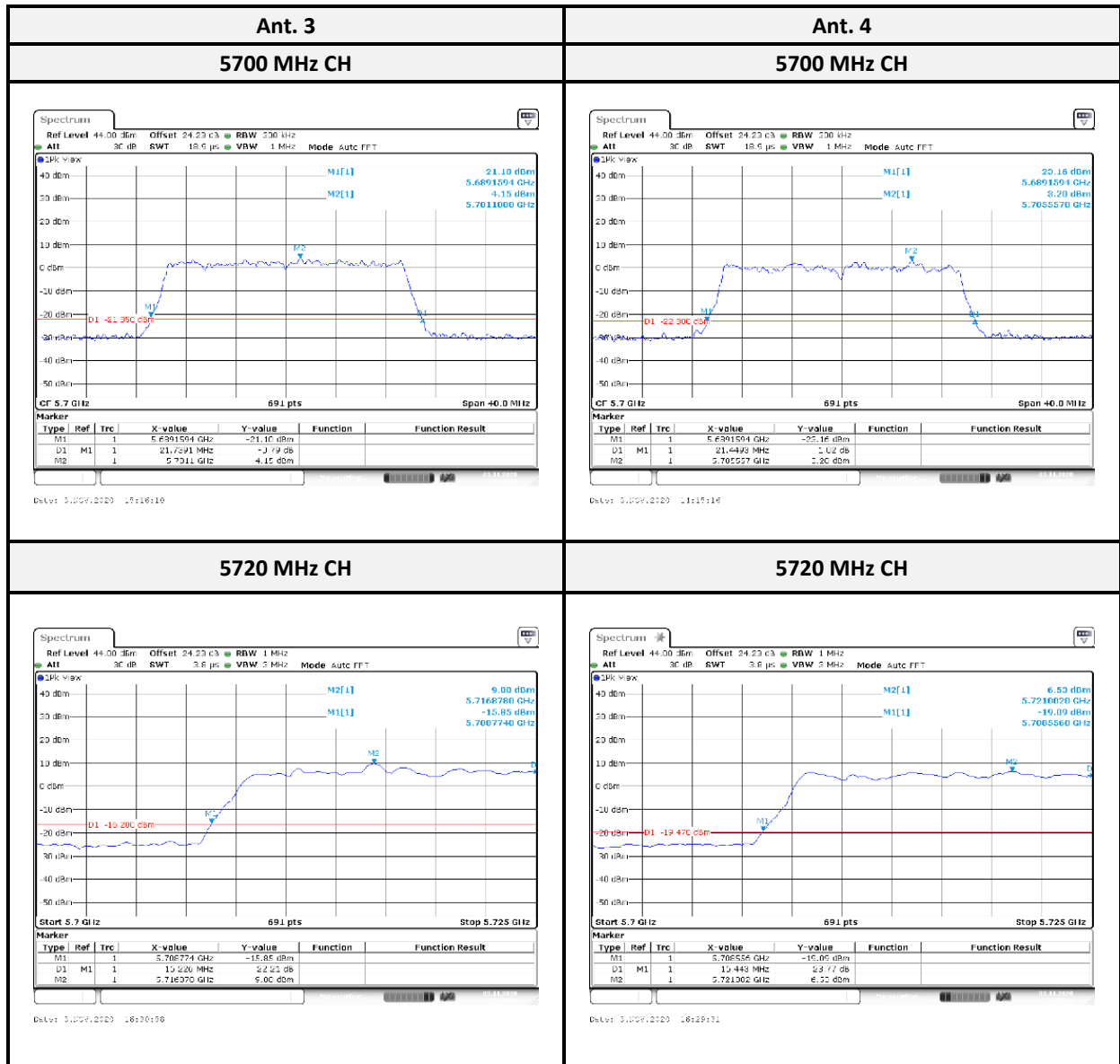

802.11ax HE40 mode:

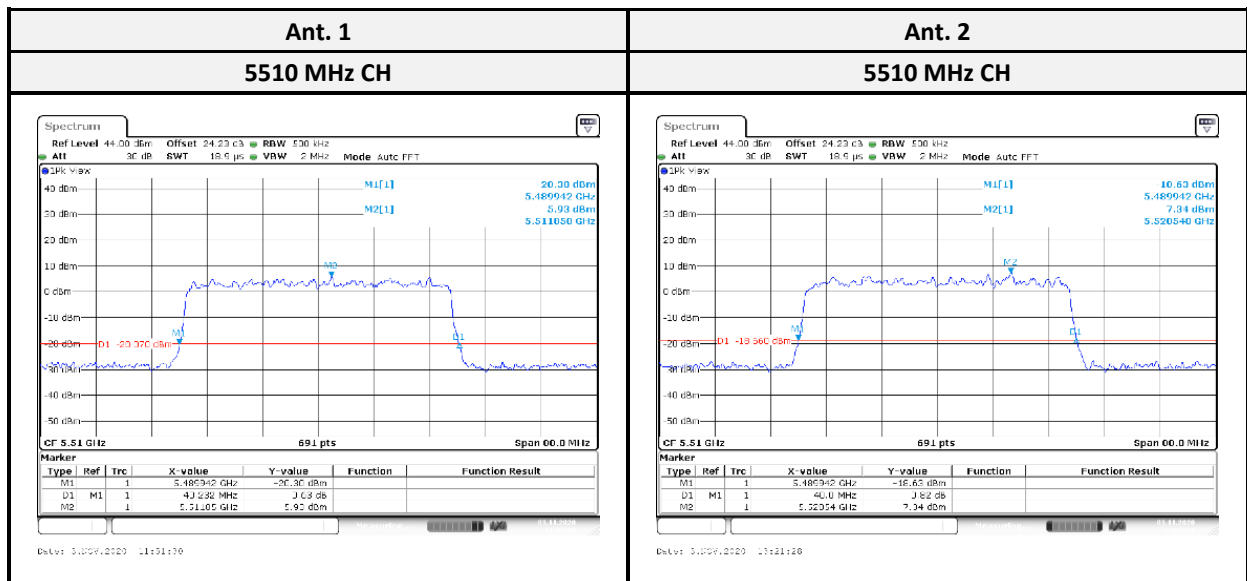

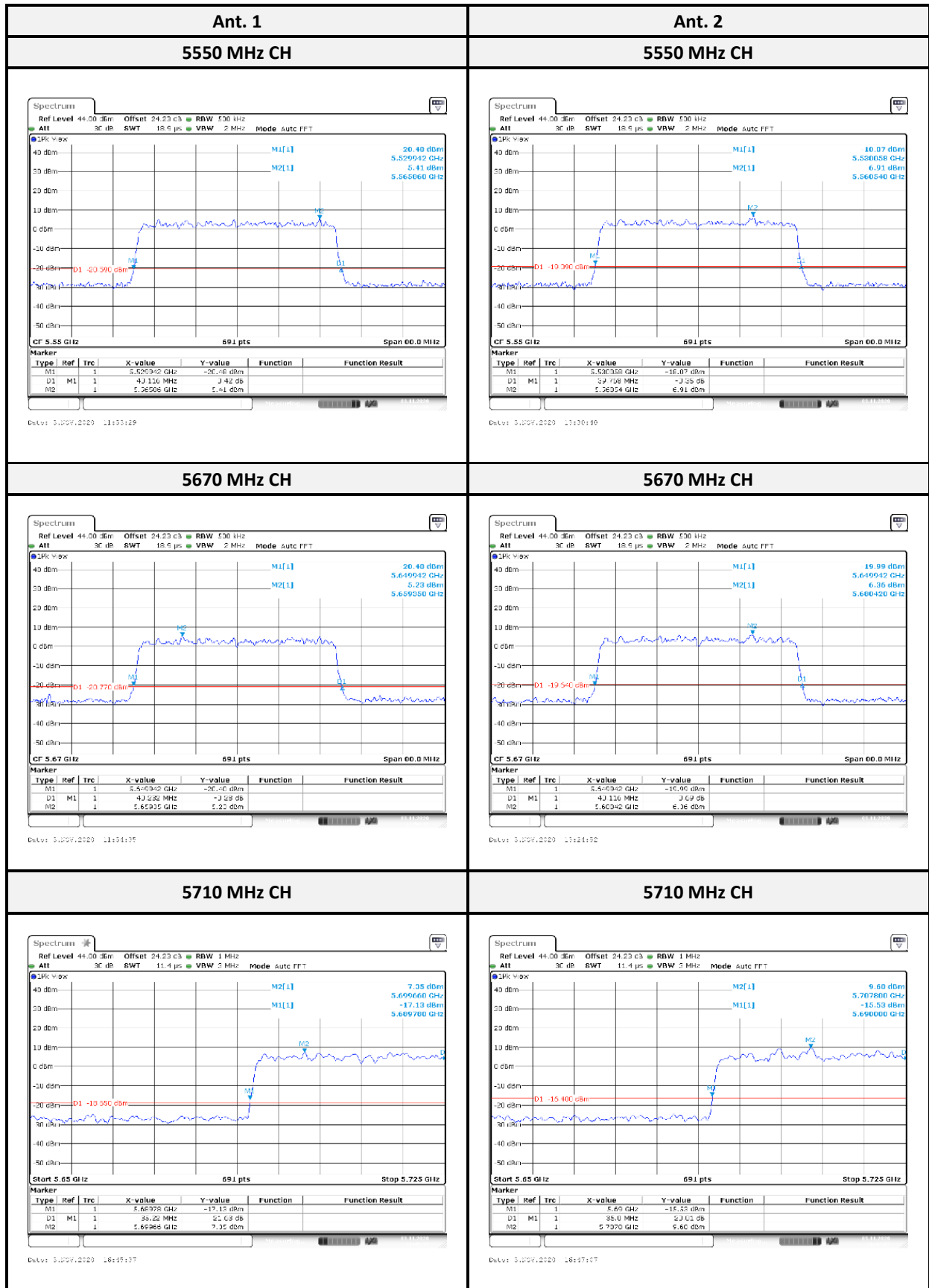

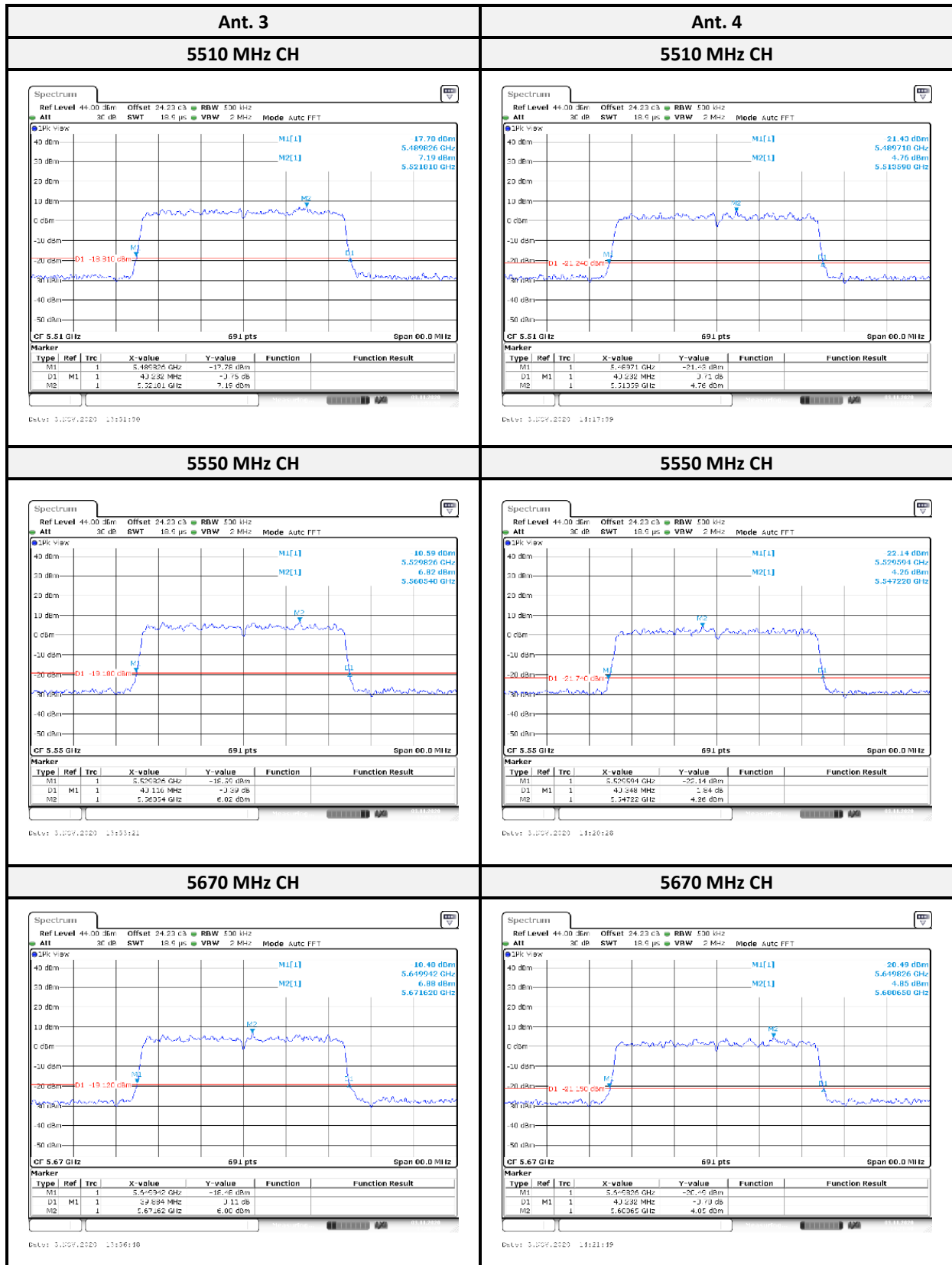

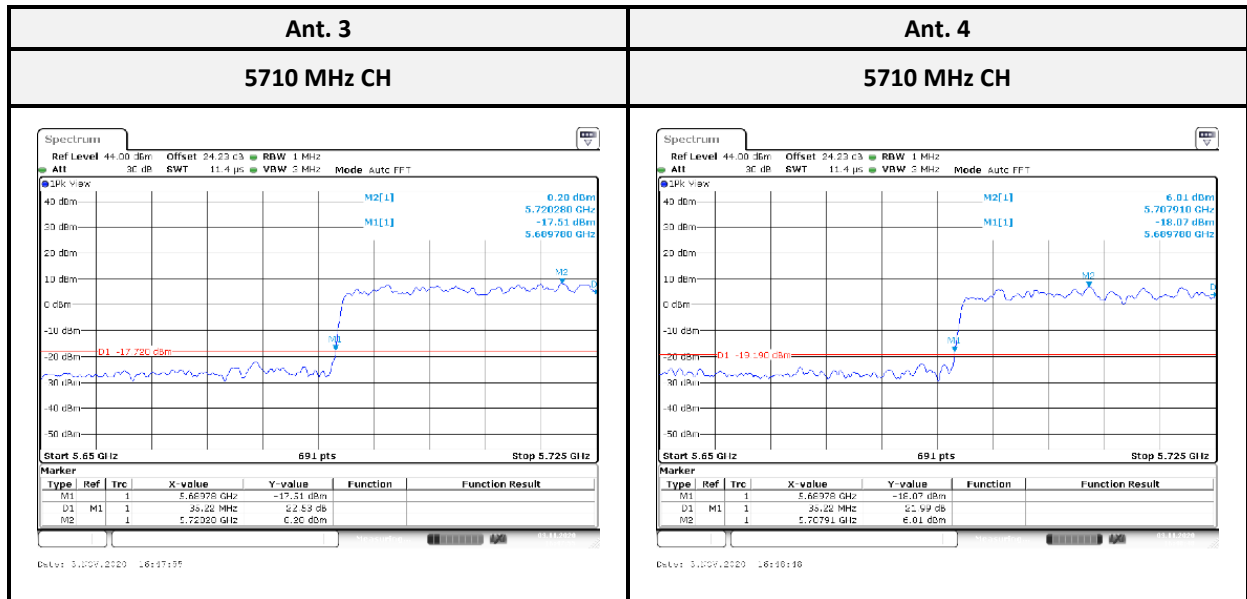

802.11ax HE80 mode:

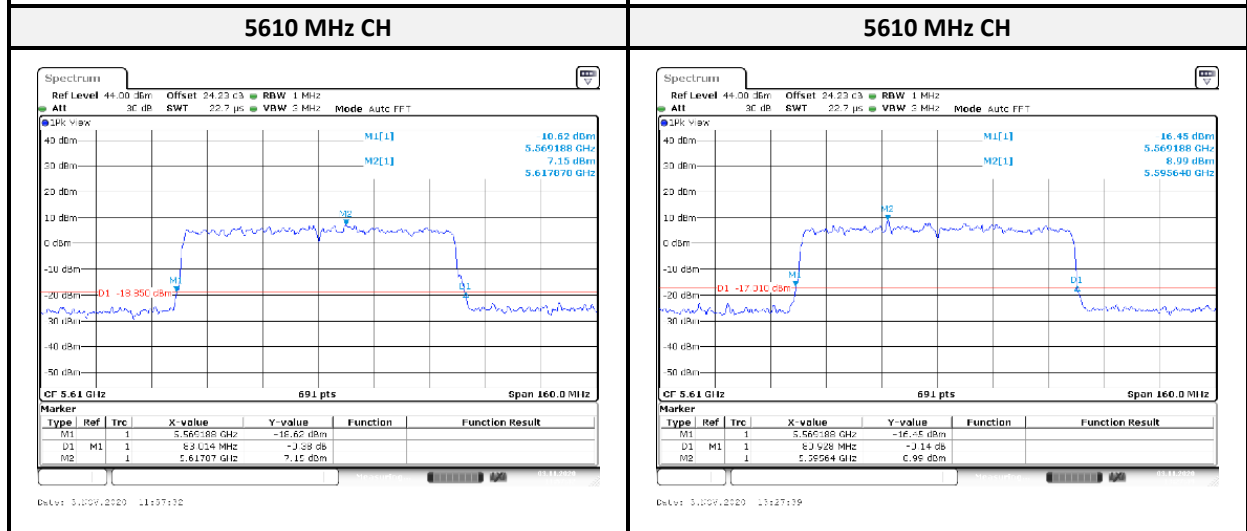
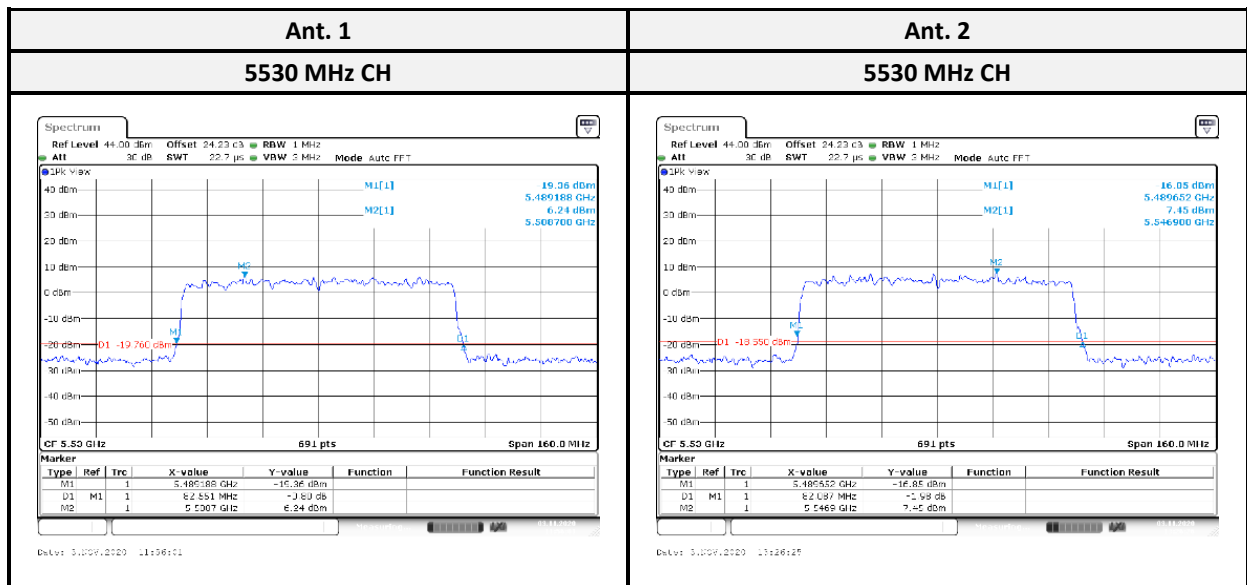

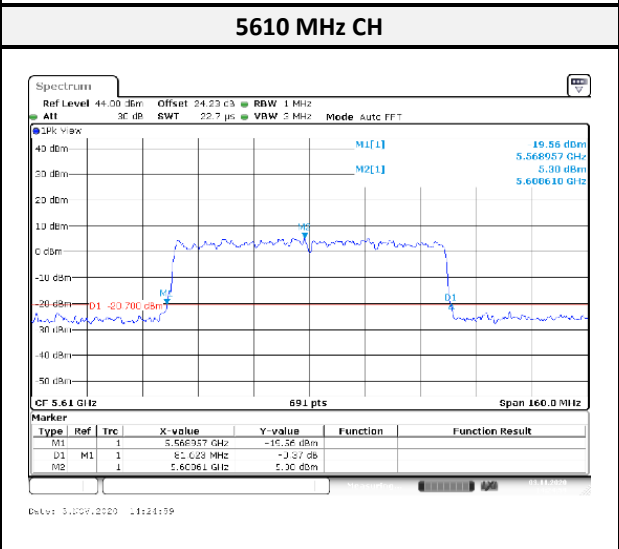
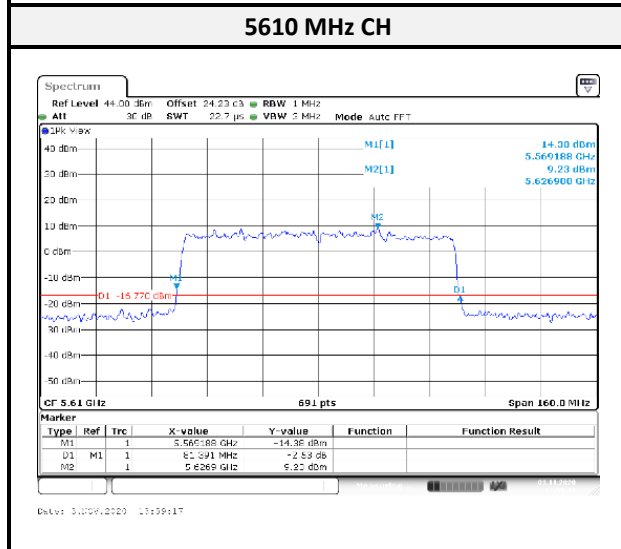
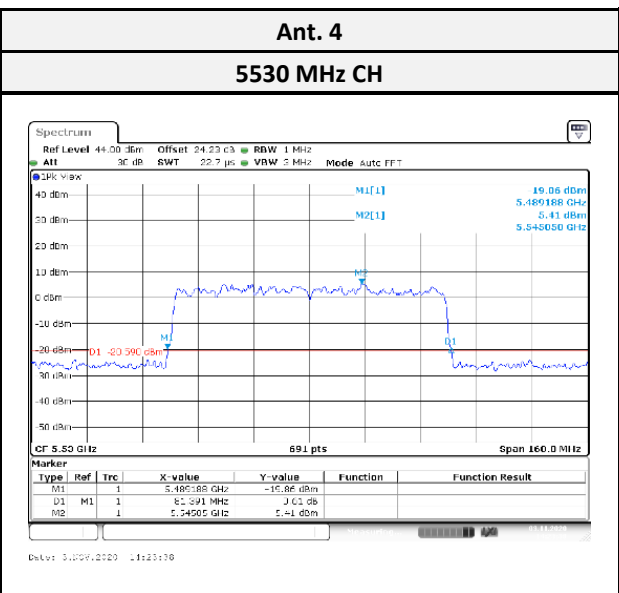
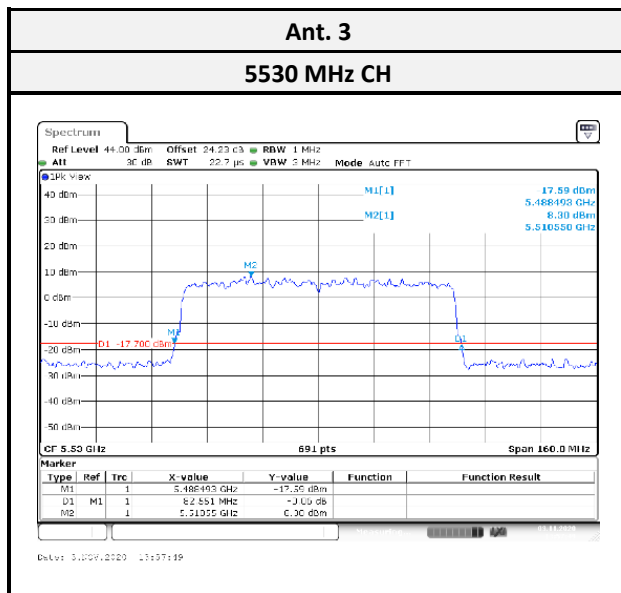
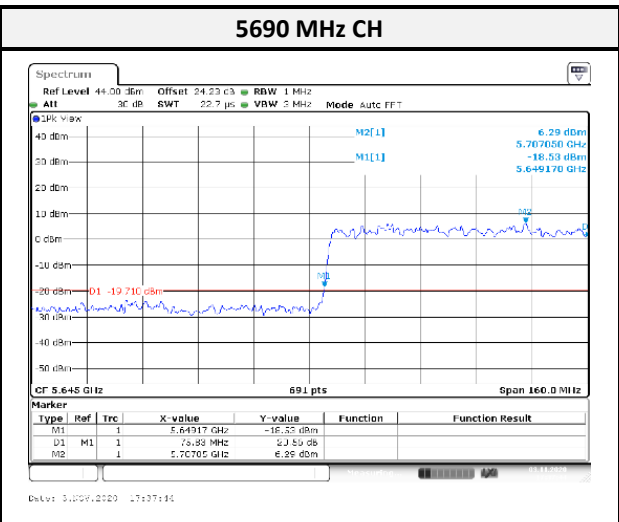
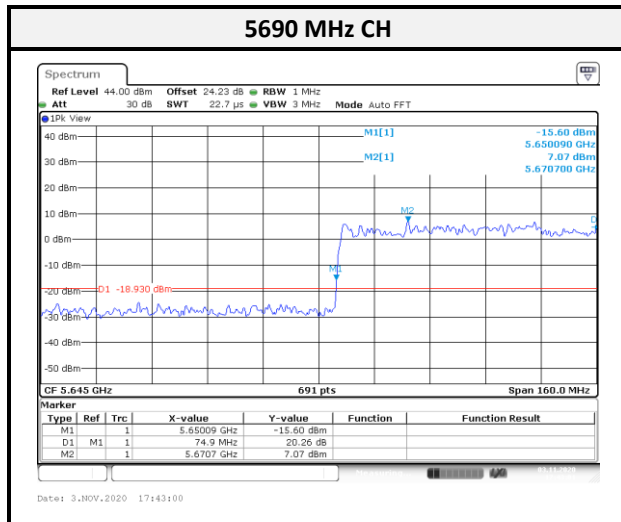

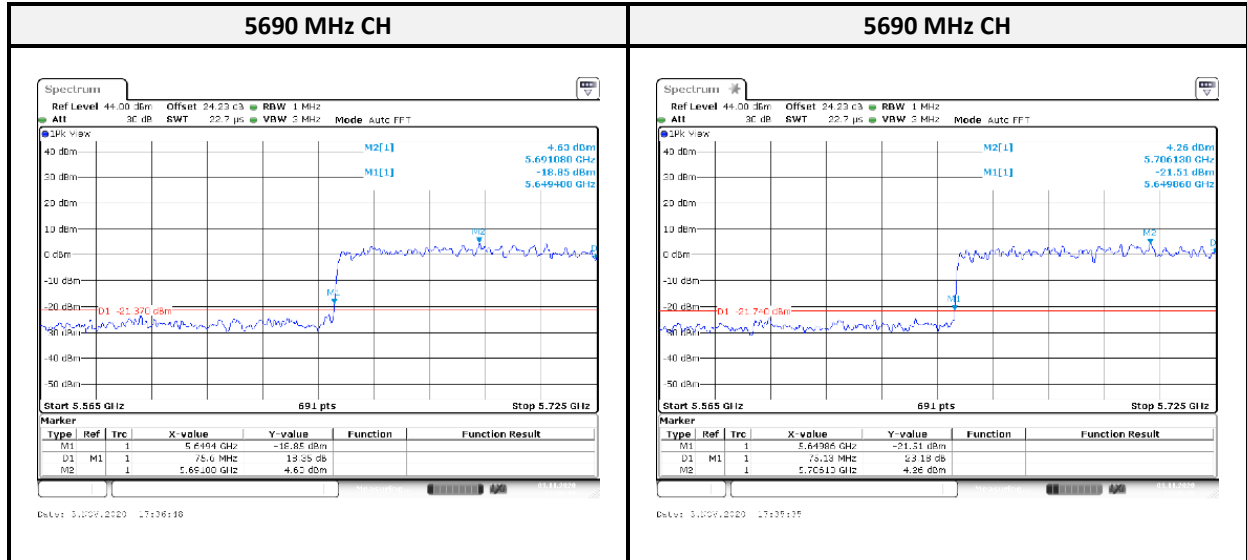

9 FCC §15.407(a)(1) – Maximum Output Power

9.1 Applicable Standard

According to FCC §15.407(a),

For the 5.25-5.35 GHz and 5.47-5.725 GHz bands, the maximum conducted output power over the frequency bands of operation shall not exceed the lesser of 250 mW or $11 \text{ dBm} + 10 \log B$, where B is the 26 dB emission bandwidth in megahertz. In addition, the maximum power spectral density shall not exceed 11 dBm in any 1 megahertz band. If transmitting antennas of directional gain greater than 6 dBi are used, both the maximum conducted output power and the maximum power spectral density shall be reduced by the amount in dB that the directional gain of the antenna exceeds 6 dBi.

9.2 Test Procedure

According to KDB 789033 D02 General UNII Test Procedures New Rules v02r01,

The use Power Meter

1. Place the EUT on a bench and set it in transmitting mode.
2. Remove the antenna from the EUT and then connect a low loss RF cable from the antenna port to a Power sensor.

9.3 Test Equipment List and Details

Description	Manufacture	Model	Serial No.	Cal. Date.	Cal. Due.
Conducted Room					
Spectrum Analyzer	Rohde & Schwarz	FSV40-N	100406	2020/03/11	2021/03/10
Cable	MTJ	MT40S	620620-MT40S-100	2020/01/09	2021/01/08

**Statement of Traceability: The testing equipment's listed above have finished the calibration by Electronics Testing Center, Taiwan (ETC) or other laboratories which were accredited by TAF or equivalent organizations. The calibration result could be traceable to the International System of Units (SI).*

9.4 Test Data

Channel	Frequency (MHz)	Average Output Power (dBm)					Limit (dBm)
		Ant. 1	Ant. 2	Ant. 3	Ant. 4	Sum	
IEEE 802.11a mode							
52	5260	12.95	13.92	14.75	12.33	19.61	24.00
60	5300	13.31	13.79	14.72	12.39	19.65	24.00
64	5320	13.12	13.82	14.66	12.18	19.56	24.00
100	5500	9.81	10.21	11.41	9.07	16.23	24.00
116	5580	10.12	10.32	11.61	9.15	16.41	24.00
140	5700	10.54	10.77	11.87	9.78	16.83	24.00
IEEE 802.11n HT20 mode							
52	5260	13.19	13.65	14.59	12.05	19.49	24.00
60	5300	13.26	13.71	14.62	12.21	19.56	24.00
64	5320	13.44	14.01	14.86	12.61	19.83	24.00
100	5500	10.65	10.09	12.08	9.36	16.68	24.00
116	5580	10.84	10.86	12.05	9.28	16.89	24.00
140	5700	10.37	10.77	11.87	9.35	16.70	24.00
144	5720	10.36	10.74	11.62	9.31	16.61	24.00
IEEE 802.11n HT40 mode							
54	5270	16.21	16.74	17.47	15.28	22.52	24.00
62	5310	14.39	15.33	16.23	14.02	21.10	24.00
102	5510	13.58	13.95	14.32	12.16	19.60	24.00
110	5550	13.54	13.13	14.18	12.05	19.31	24.00
134	5670	13.57	13.19	14.11	12.13	19.33	24.00
142	5710	13.78	13.26	14.65	12.36	19.61	24.00

Note: Power direction gain not over 6 dBi, not need modify limit. (UNII-2a: 1.79 dBi and UNII-2c is 2.20 dBi)

Channel	Frequency (MHz)	Average Output Power (dBm)					Limit (dBm)
		Ant. 1	Ant. 2	Ant. 3	Ant. 4	Sum	
IEEE 802.11ac VHT20 mode							
52	5260	13.38	13.84	14.65	12.26	19.64	24.00
60	5300	13.42	13.89	14.73	12.37	19.71	24.00
64	5320	13.65	14.11	15.12	12.66	20.00	24.00
100	5500	10.77	10.34	12.35	9.59	16.90	24.00
116	5580	11.16	11.05	12.11	9.37	17.05	24.00
140	5700	10.54	10.92	11.98	9.66	16.88	24.00
144	5720	10.56	10.88	11.74	9.62	16.79	24.00
IEEE 802.11ac VHT40 mode							
54	5270	16.37	16.93	17.58	15.47	22.68	24.00
62	5310	14.74	15.74	16.39	14.13	21.36	24.00
102	5510	13.73	14.05	14.65	12.37	19.80	24.00
110	5550	13.62	13.62	14.34	12.18	19.53	24.00
134	5670	13.65	13.66	14.36	12.26	19.57	24.00
142	5710	13.66	13.73	14.73	12.55	19.76	24.00
IEEE 802.11ac VHT80 mode							
58	5290	15.05	15.73	16.42	14.15	21.44	24.00
106	5530	14.78	15.89	16.59	13.62	21.38	24.00
122	5610	15.69	15.96	17.31	14.32	21.97	24.00
138	5690	16.11	15.92	17.26	14.38	22.06	24.00
IEEE 802.11ax HE20 mode							
52	5260	13.48	14.01	14.89	12.46	19.82	24.00
60	5300	13.55	14.04	15.01	12.68	19.92	24.00
64	5320	13.86	14.33	15.29	12.96	20.21	24.00
100	5500	10.92	10.59	12.53	10.06	17.15	24.00
116	5580	11.32	11.18	12.19	9.69	17.21	24.00
140	5700	10.72	11.02	12.06	9.97	17.03	24.00
144	5720	10.71	11.05	12.07	9.95	17.03	24.00

Note: Power direction gain not over 6 dBi, not need modify limit. (UNII-2a: 1.79 dBi and UNII-2c is 2.20 dBi)

Channel	Frequency (MHz)	Average Output Power (dBm)					Limit (dBm)
		Ant. 1	Ant. 2	Ant. 3	Ant. 4	Sum	
IEEE 802.11ax HE40 mode							
54	5270	16.61	17.09	17.78	15.65	22.87	24.00
62	5310	14.91	15.92	16.53	14.46	21.55	24.00
102	5510	13.86	14.12	14.96	12.58	19.98	24.00
110	5550	13.77	14.06	14.79	12.34	19.85	24.00
134	5670	13.75	14.15	14.61	12.46	19.83	24.00
142	5710	13.78	14.24	14.59	12.73	19.91	24.00
IEEE 802.11ax HE80 mode							
58	5290	15.18	15.95	16.57	14.31	21.60	24.00
106	5530	15.13	16.26	16.72	13.81	21.64	24.00
122	5610	16.11	16.87	17.55	14.65	22.44	24.00
138	5690	16.23	16.85	17.41	14.62	22.42	24.00

Note: Power direction gain not over 6 dBi, not need modify limit. (UNII-2a: 1.79 dBi and UNII-2c is 2.20 dBi)

10 FCC §15.407(a) – Power Spectral Density

10.1 Applicable Standard

According to FCC §15.407(a),

For the 5.25-5.35 GHz and 5.47-5.725 GHz bands, the maximum conducted output power over the frequency bands of operation shall not exceed the lesser of 250 mW or 11 dBm + 10 log B, where B is the 26 dB emission bandwidth in megahertz. In addition, the maximum power spectral density shall not exceed 11 dBm in any 1 megahertz band. If transmitting antennas of directional gain greater than 6 dBi are used, both the maximum conducted output power and the maximum power spectral density shall be reduced by the amount in dB that the directional gain of the antenna exceeds 6 dBi..

10.2 Test Procedure

According to KDB 789033 D02 General UNII Test Procedures New Rules v02r01 and ANSI 63.10: 2013 Sec 10.3.7.

For devices operating in the bands 5.15-5.25 GHz, 5.25-5.35 GHz, and 5.47-5.725 GHz, the above procedures make use of 1 MHz RBW to satisfy directly the 1 MHz reference bandwidth specified in Section 15.407(a)(5).

For devices operating in the band 5.725-5.85 GHz, the rules specify a measurement bandwidth of 500 kHz.

Many spectrum analyzers do not have 500 kHz RBW, thus a narrower RBW may need to be used. The rules permit the use of a RBWs less than 1 MHz, or 500 kHz, “provided that the measured power is integrated over the full reference bandwidth” to show the total power over the specified measurement bandwidth (i.e., 1 MHz, or 500 kHz). If measurements are performed using a reduced resolution bandwidth (< 1 MHz, or < 500 kHz) and integrated over 1 MHz, or 500 kHz bandwidth, the following adjustments to the procedures apply:

- a) Set the RBW to 1 MHz.
- b) Set the VBW to be at least 1 MHz (a VBW of 3 MHz is desirable).
- c) Set the frequency span to examine the spectrum across a convenient frequency segment (e.g., 600 MHz).
- d) Select the power averaging (rms) detector.
- e) Set the sweep time so that there is no more than a 1 ms integration period over each measurement bin.
- f) Care must be taken to ensure that the measurements are performed during a period of continuous transmission or are corrected upward for duty cycle.

10.3 Test Equipment List and Details

Description	Manufacture	Model	Serial No.	Cal. Date.	Cal. Due.
Conducted Room					
Spectrum Analyzer	Rohde & Schwarz	FSV40	101140	2020/03/11	2021/03/10
Cable	WOKEN	SFL402	S02-160323-07	Each use	-

***Statement of Traceability:** The testing equipment's listed above have finished the calibration by Electronics Testing Center, Taiwan (ETC) or other laboratories which were accredited by TAF or equivalent organizations. The calibration result could be traceable to the International System of Units (SI).

10.4 Test Data and Test Plot

UNII-2a

Mode	Channel	Frequency (MHz)	PSD (dBm/MHz)				Total PSD (dBm/MHz)	Duty Factor (dB)	Limit (dBm/MHz)
			Ant. 1	Ant. 2	Ant. 3	Ant. 4			
802.11a	52	5260	2.37	3.27	4.02	2.09	9.02	0.15	9.19
	60	5300	2.61	3.10	4.08	2.09	9.05	0.15	9.19
	64	5320	2.24	3.10	3.79	2.03	8.87	0.15	9.19
802.11ax HE20	52	5260	3.13	2.87	3.60	1.75	8.91	0.04	9.19
	60	5300	2.68	2.99	3.49	1.86	8.82	0.04	9.19
	64	5320	2.30	3.04	3.86	1.59	8.80	0.04	9.19
802.11ax HE40	54	5270	2.20	3.44	3.65	1.57	8.82	0.08	9.19
	62	5310	0.43	1.88	2.33	0.65	7.42	0.08	9.19
802.11ax HE80	58	5290	-2.49	-0.10	-0.96	-1.83	4.77	0.22	9.19

Note: Power Density Direct Gain is 7.81 dBi, so the Limit is 9.19 dBi. $(11.00 - (7.81 - 6.00)) = 9.19$

UNII-2c

Mode	Channel	Frequency (MHz)	PSD (dBm/MHz)				Total PSD (dBm/MHz)	Duty Factor (dB)	Limit (dBm/MHz)
			Ant. 1	Ant. 2	Ant. 3	Ant. 4			
802.11a	100	5500	-0.71	-0.38	0.67	-0.58	5.80	0.15	8.78
	116	5580	-0.72	-0.37	1.18	-1.07	5.86	0.15	8.78
	140	5700	-0.45	-0.04	1.27	-1.02	6.04	0.15	8.78
802.11ax HE20	100	5500	-0.63	-0.69	1.21	-0.61	5.92	0.04	8.78
	116	5580	-0.45	-0.01	0.98	-0.73	6.02	0.04	8.78
	140	5700	-0.78	-0.23	0.84	-0.42	5.92	0.04	8.78
	144	5720	-1.08	-0.29	0.74	-0.07	5.90	0.04	8.78
802.11ax HE40	102	5510	-0.31	0.59	0.81	-1.45	6.02	0.08	8.78
	110	5550	-0.50	0.39	0.68	-1.05	5.95	0.08	8.78
	134	5670	-0.28	0.24	0.41	-1.12	5.87	0.08	8.78
	142	5710	-0.44	0.24	0.82	-2.23	5.76	0.08	8.78
802.11ax HE80	106	5530	-1.57	-0.35	-0.09	-2.00	5.09	0.22	8.78
	122	5610	-0.43	0.38	0.79	-1.90	5.85	0.22	8.78
	138	5690	-1.09	0.25	0.71	-1.72	5.67	0.22	8.78

Note: Power Density Direct Gain is 8.22 dBi, so the Limit is 8.78 dBi. $(11.00 - (8.22 - 6.00)) = 8.78$

For UNII-2a
802.11a mode

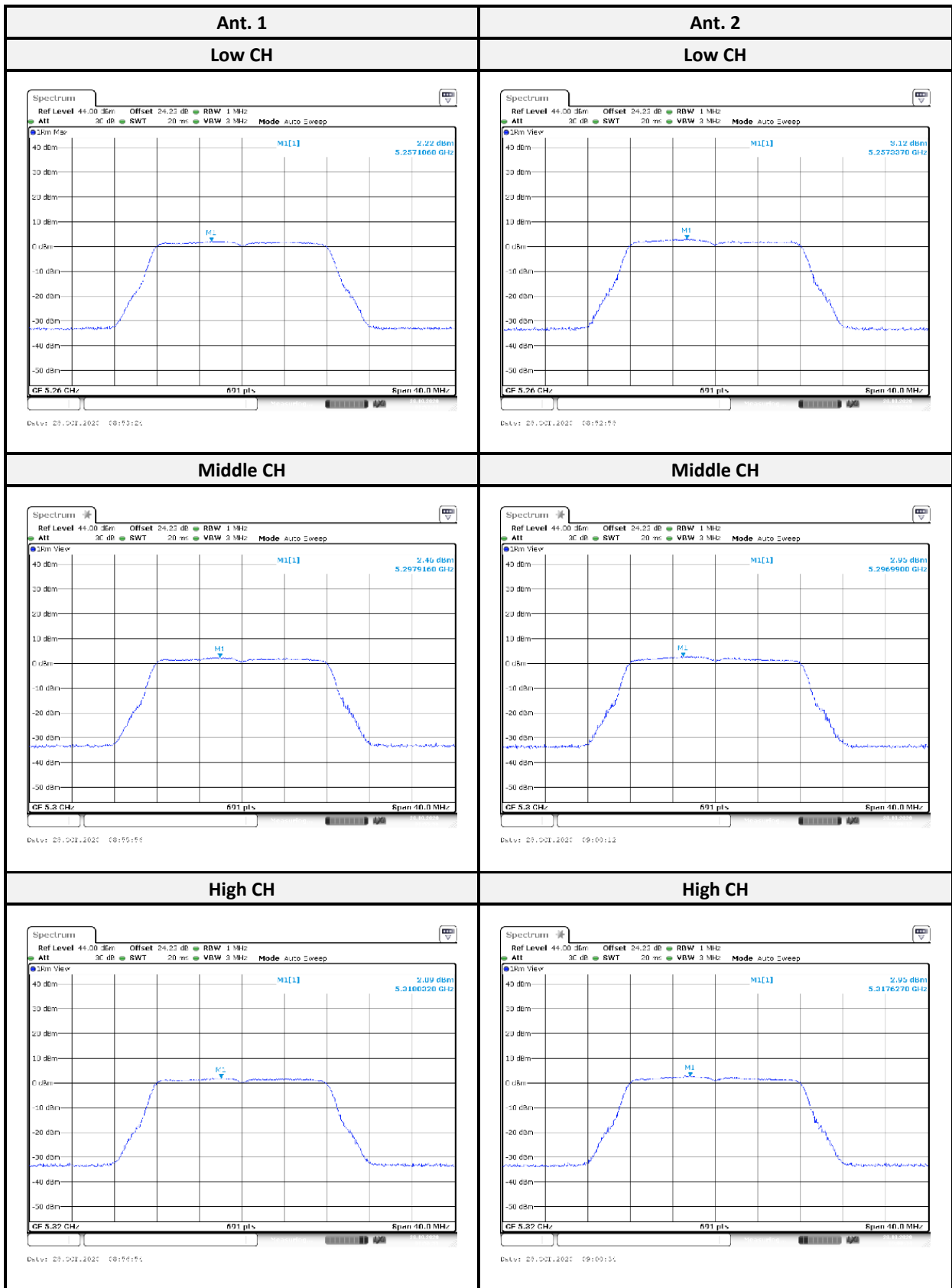

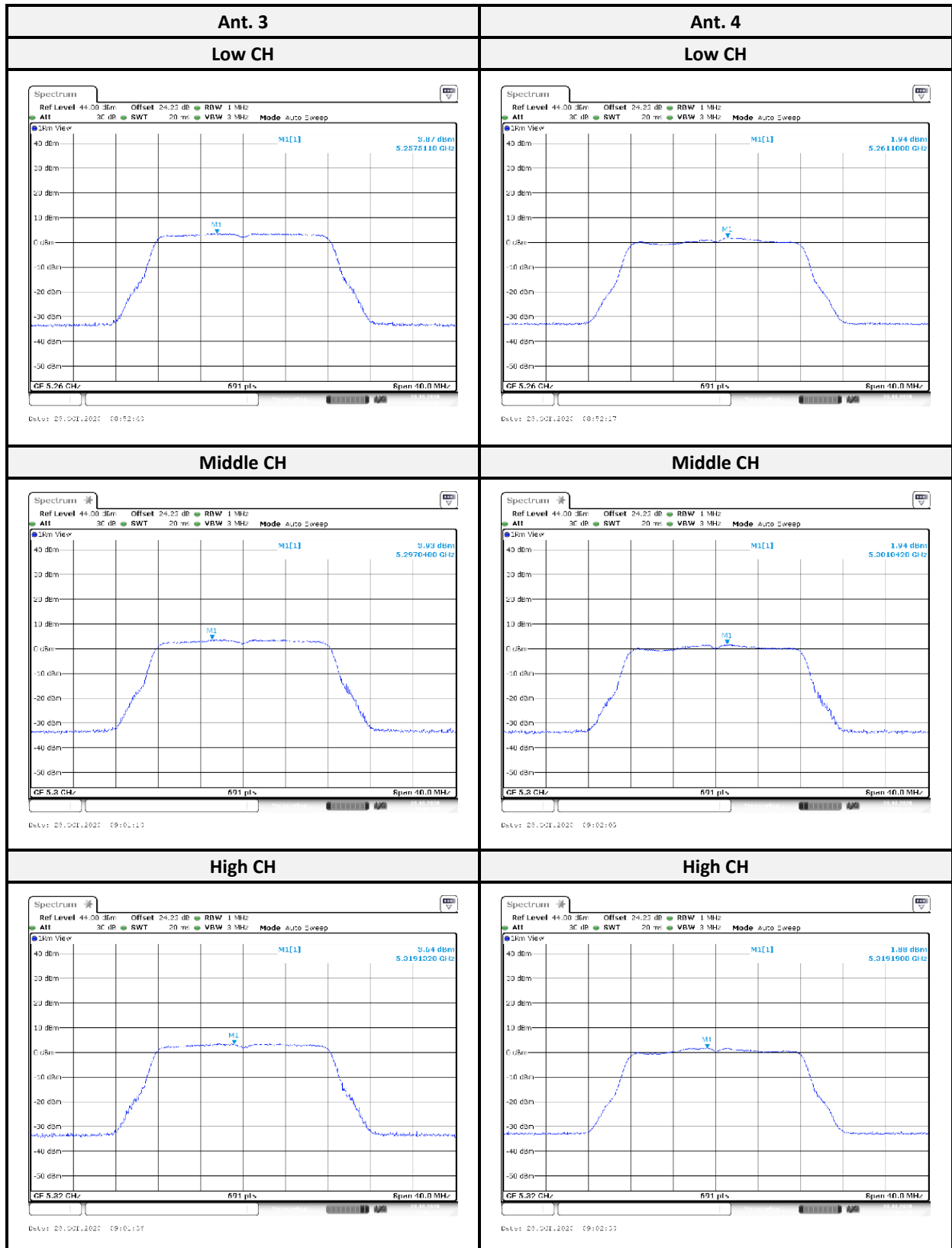

802.11ax HE20 mode:

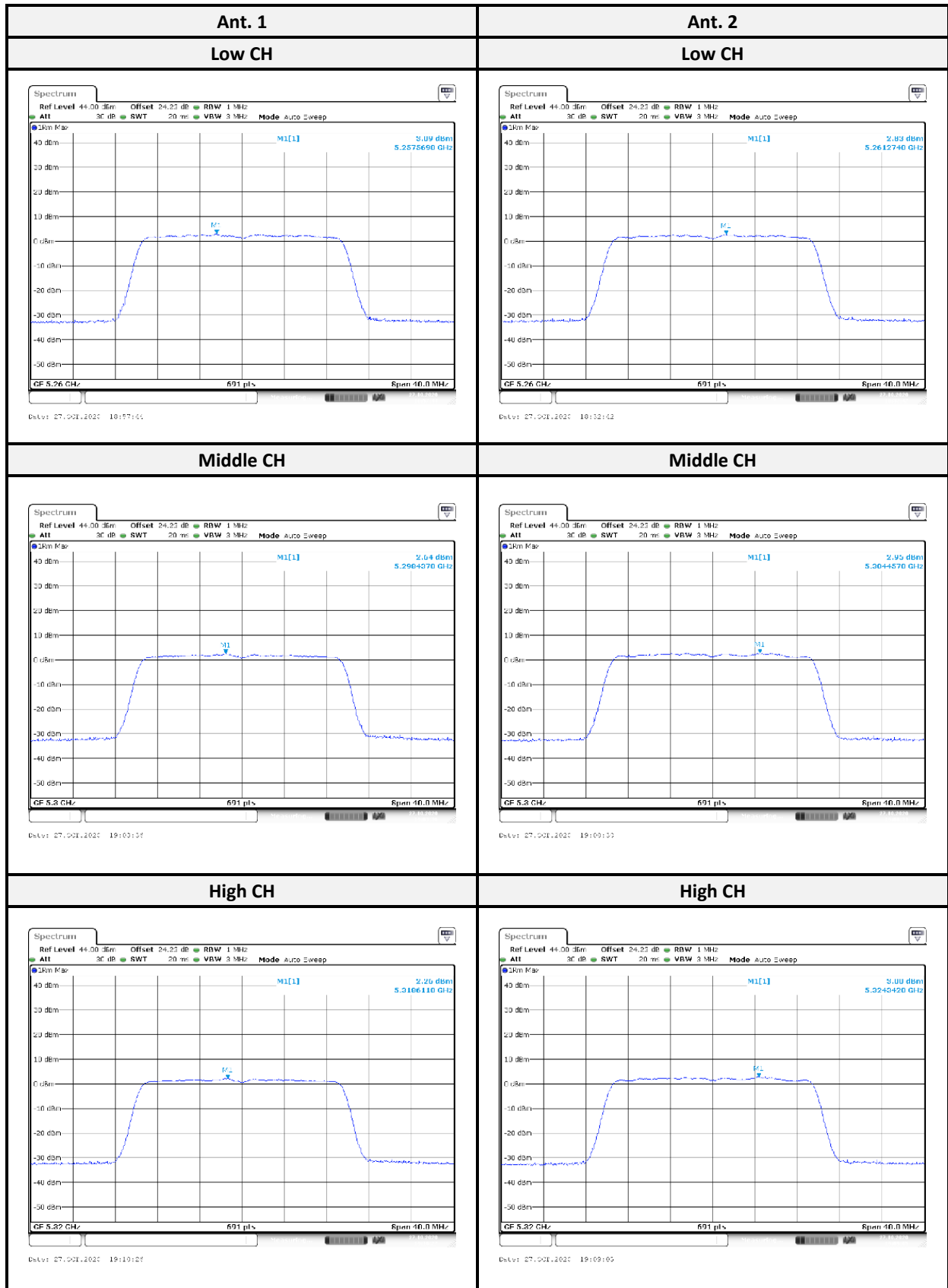

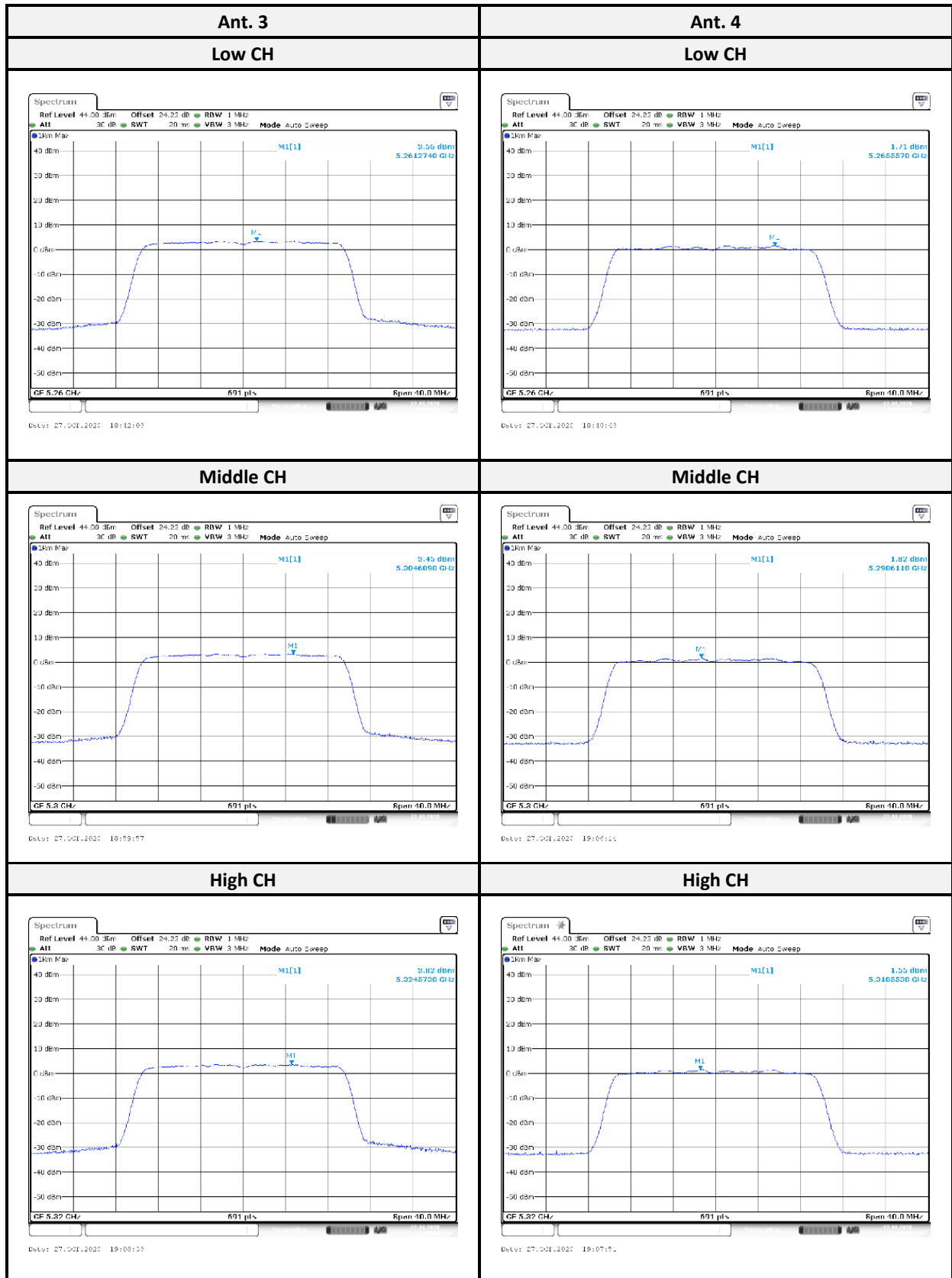

802.11ax HE40 mode:

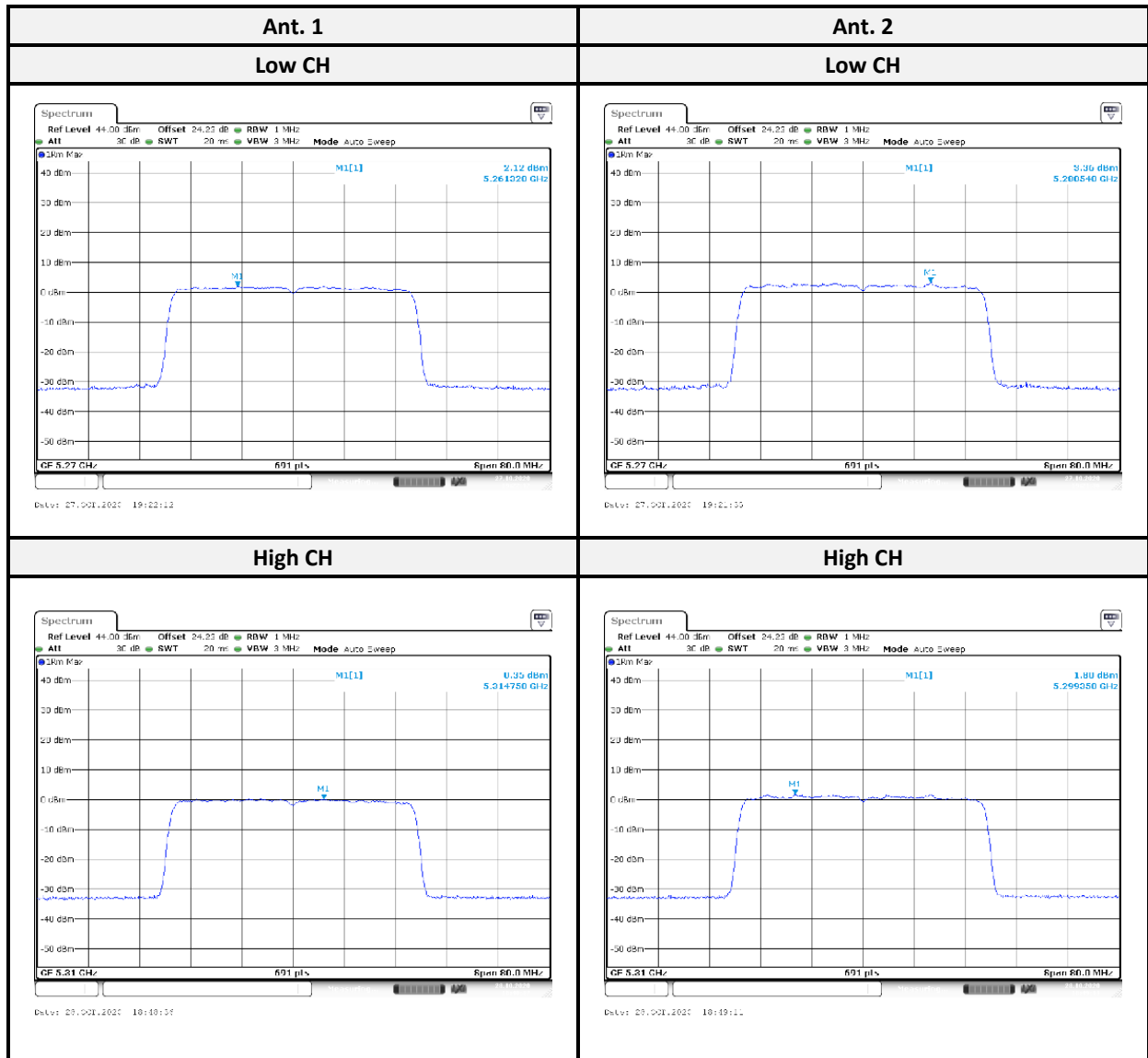

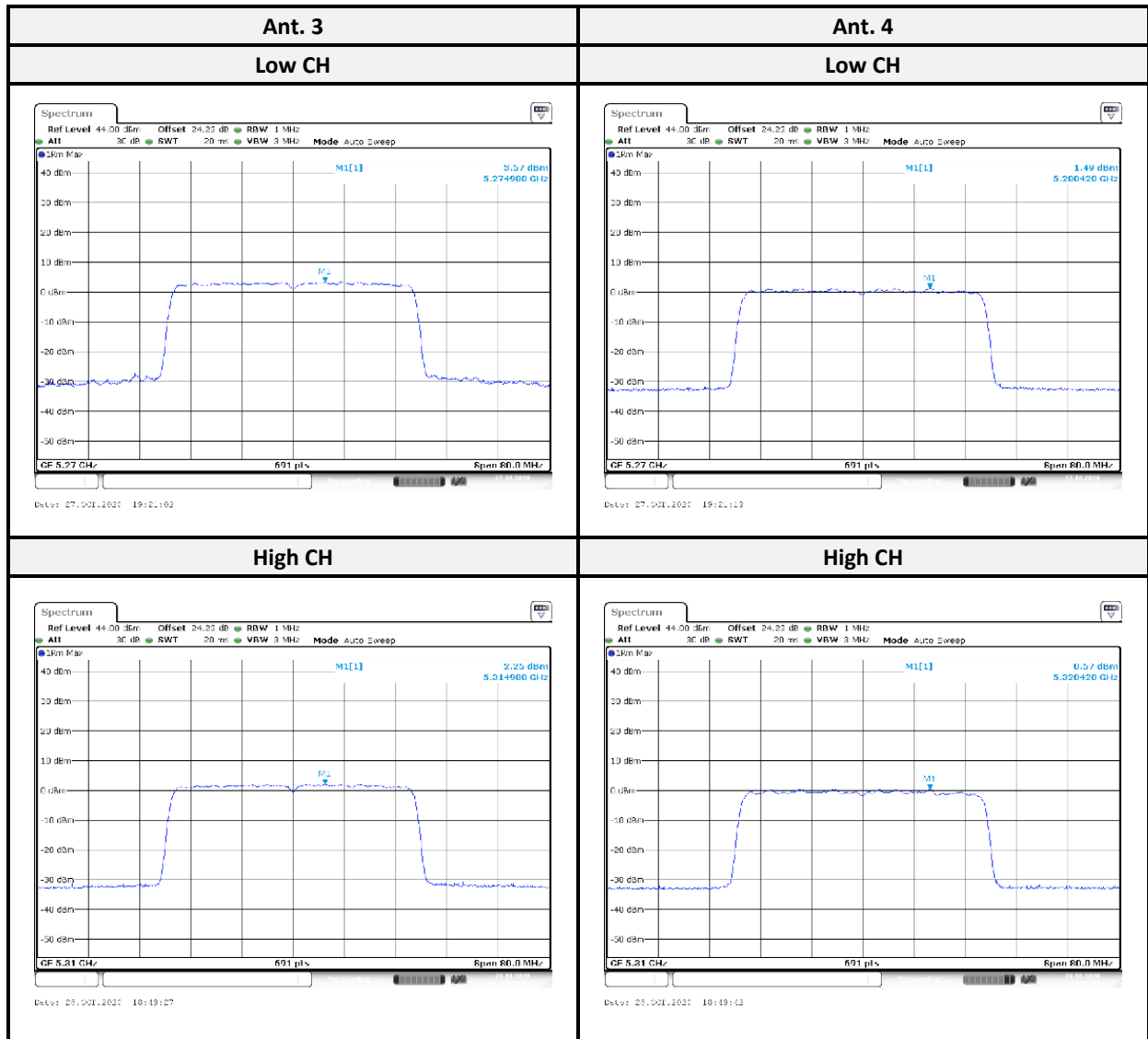

802.11ax HE80 mode:

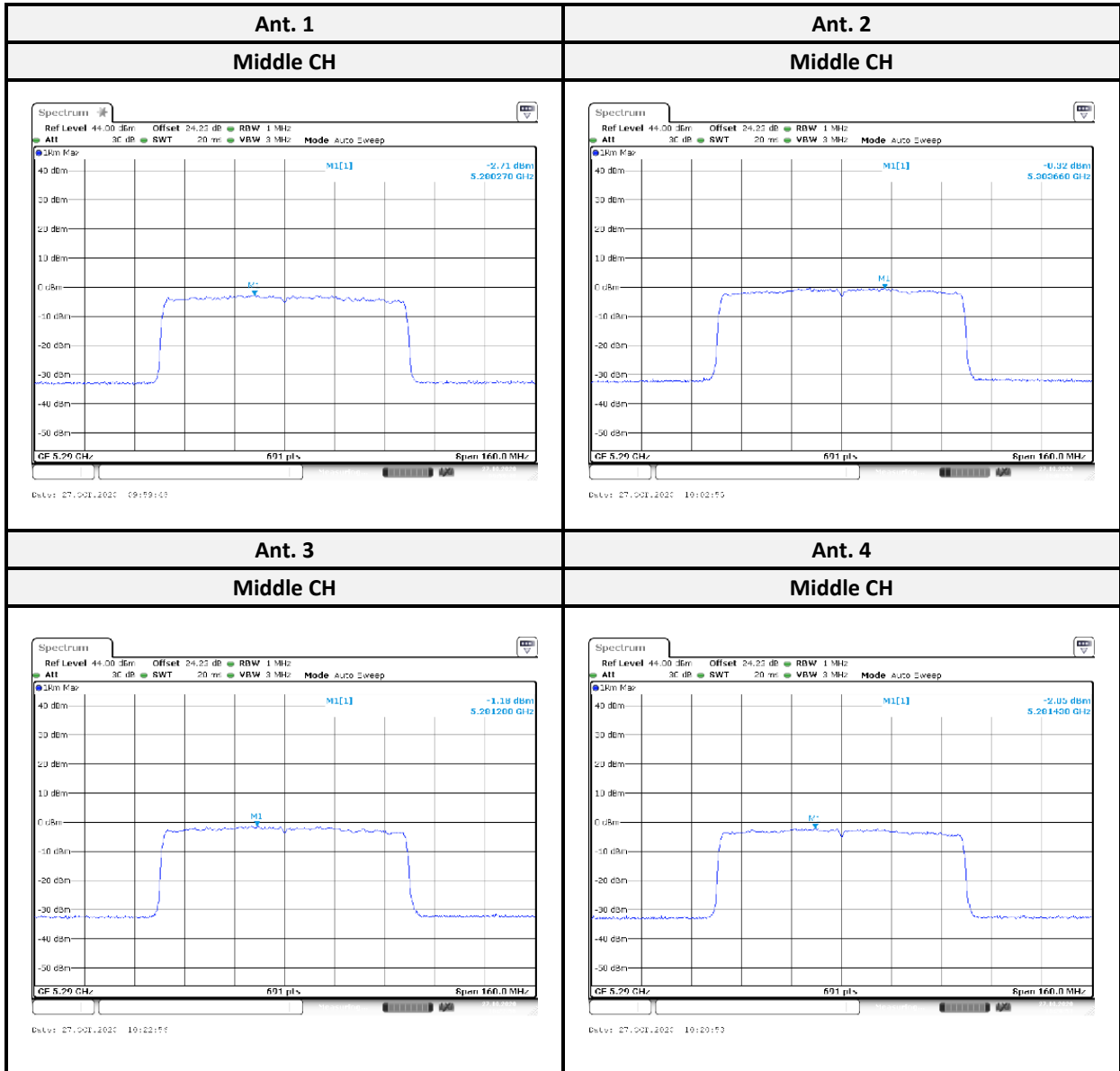

For UNII-2c

802.11a mode

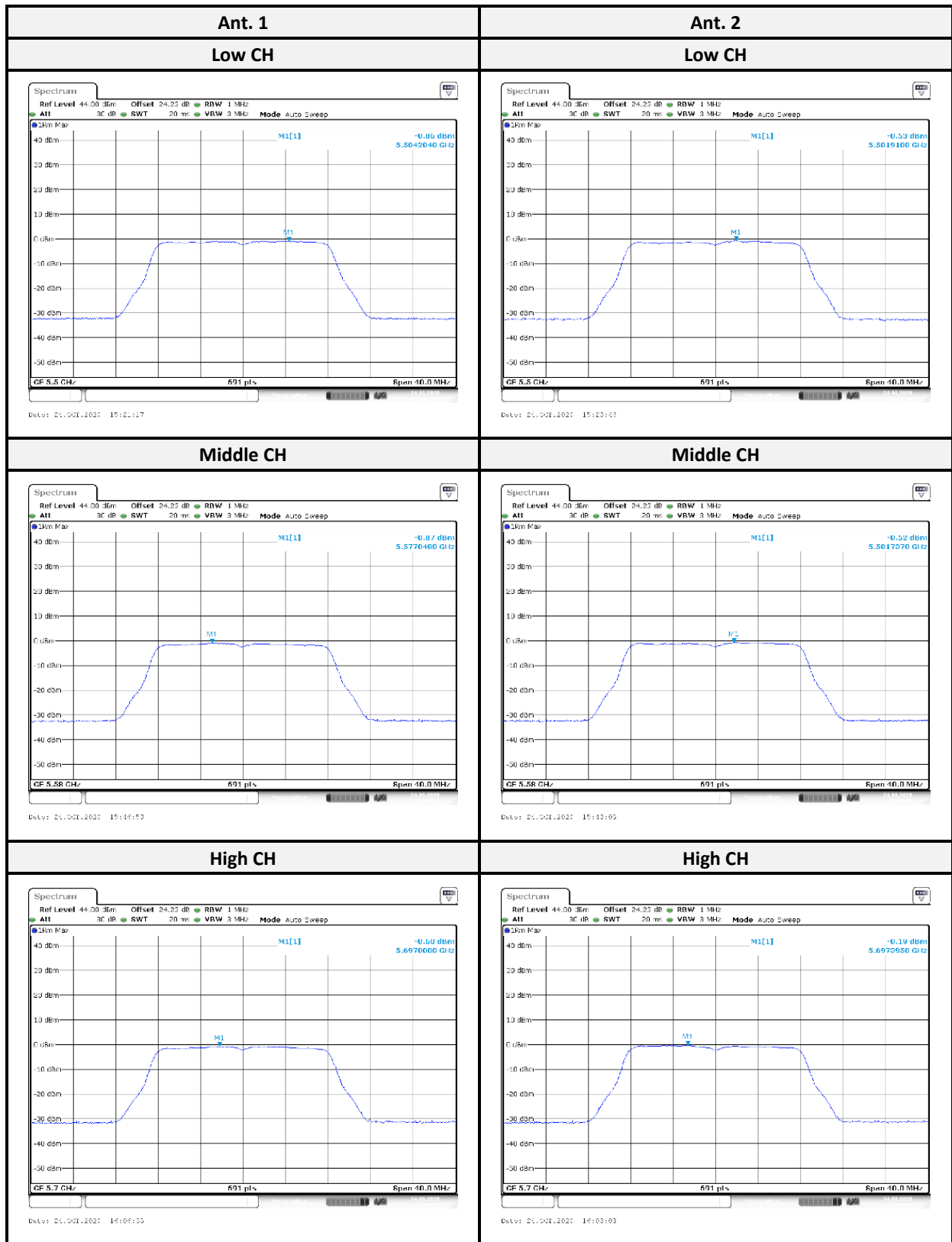

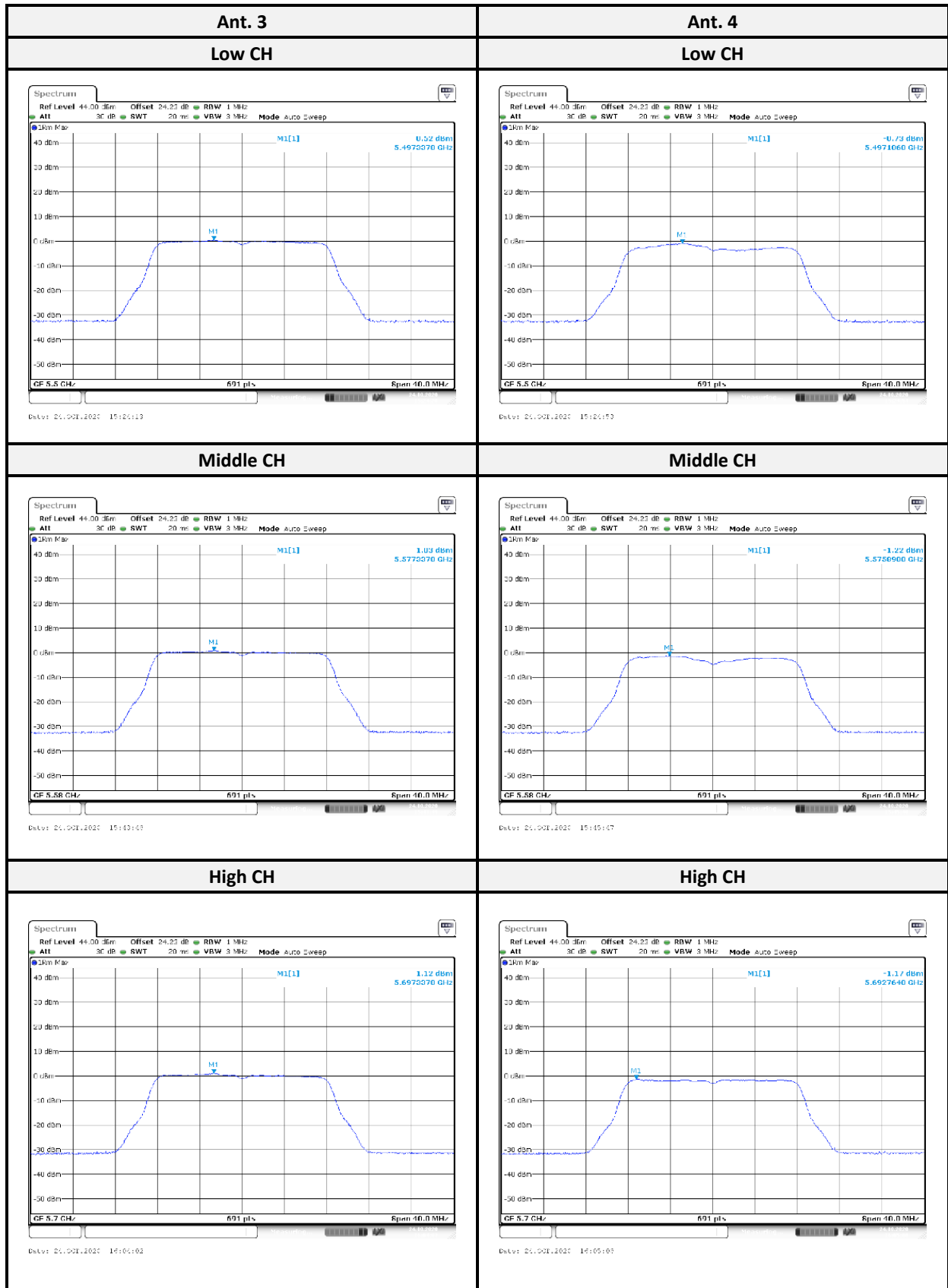

802.11ax HE20 mode:

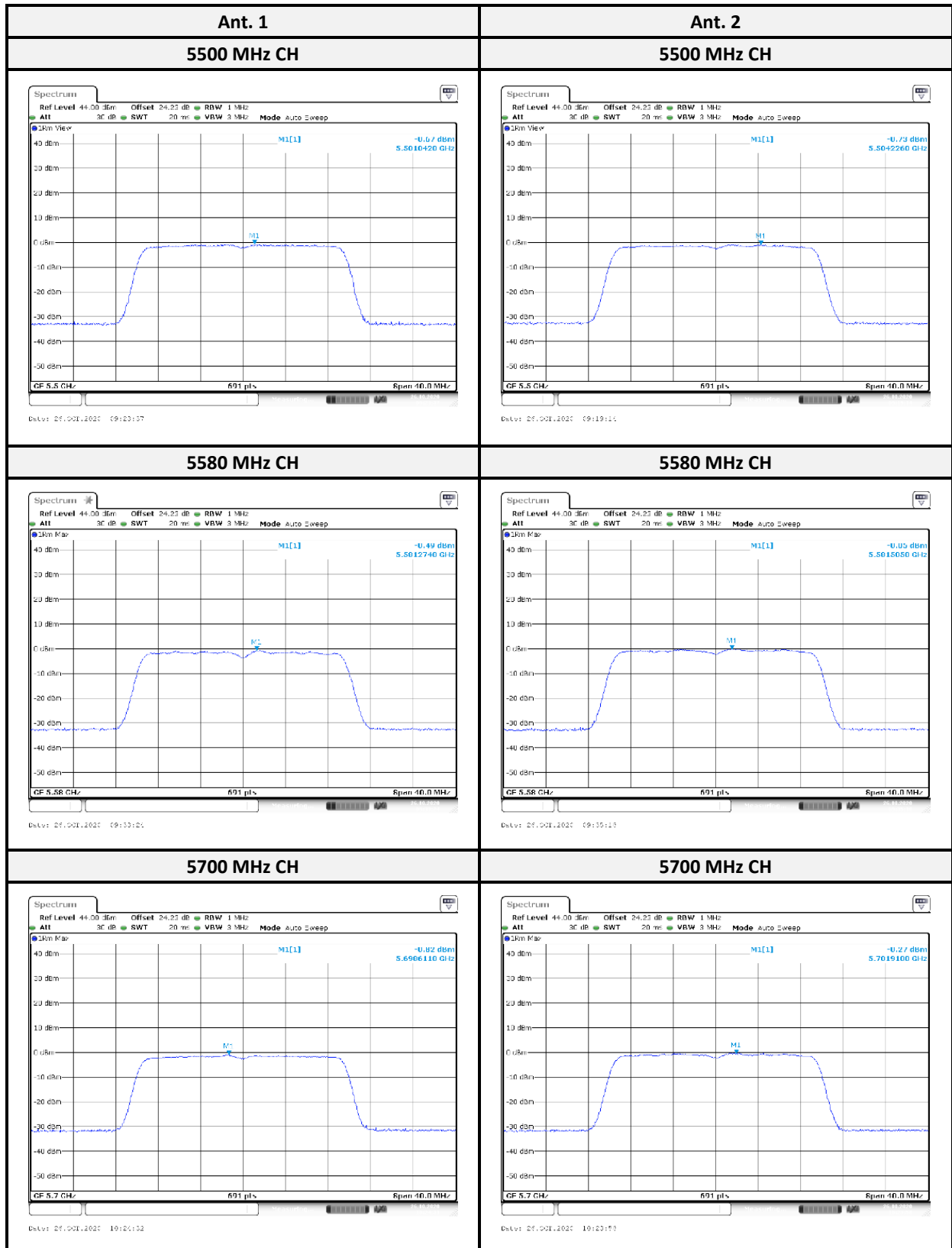

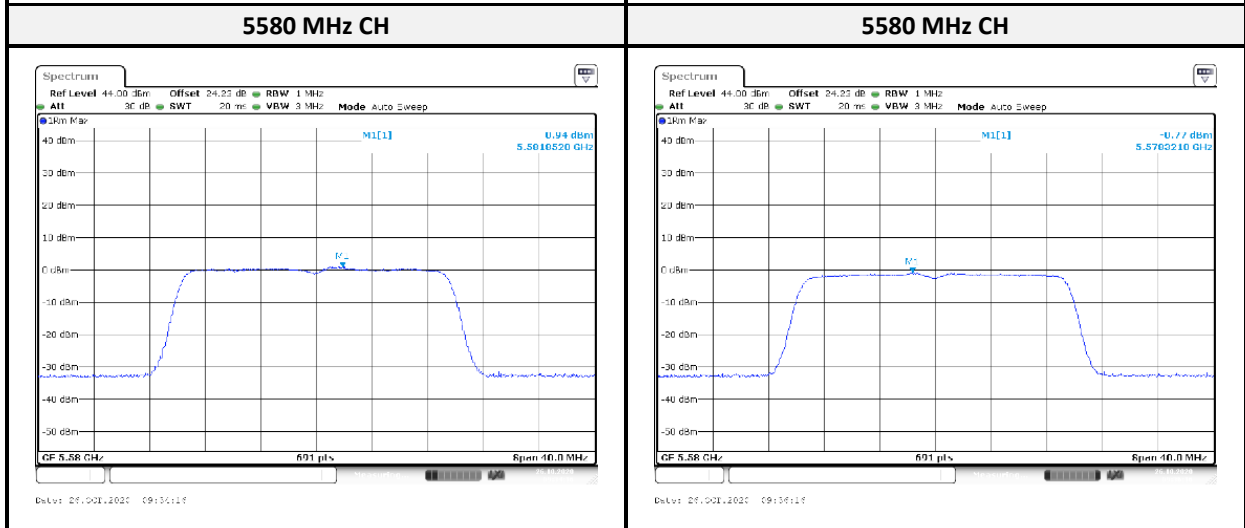
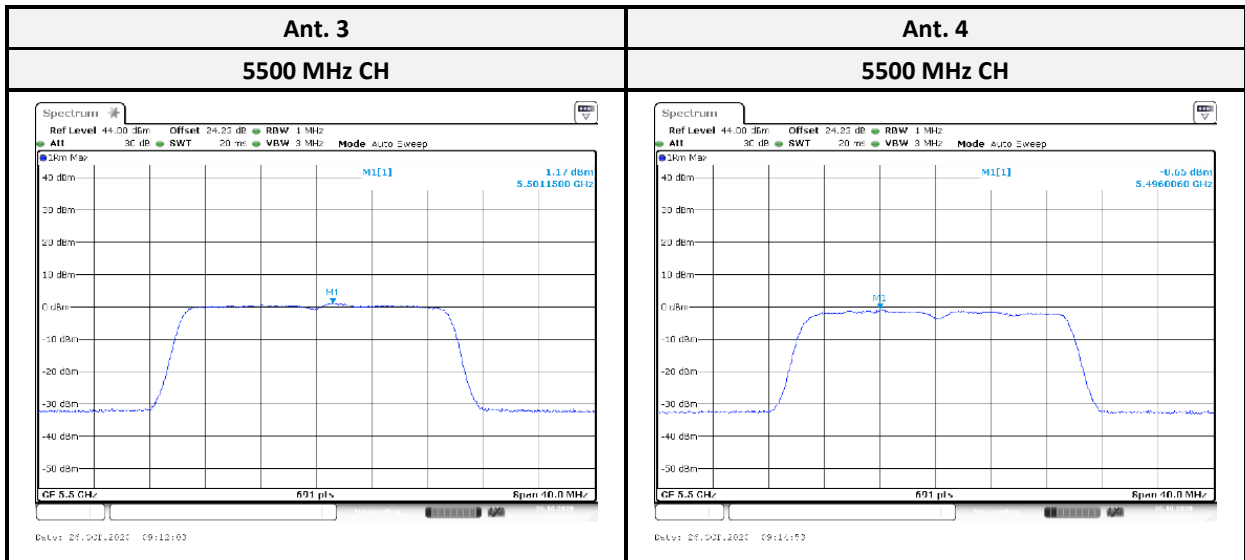
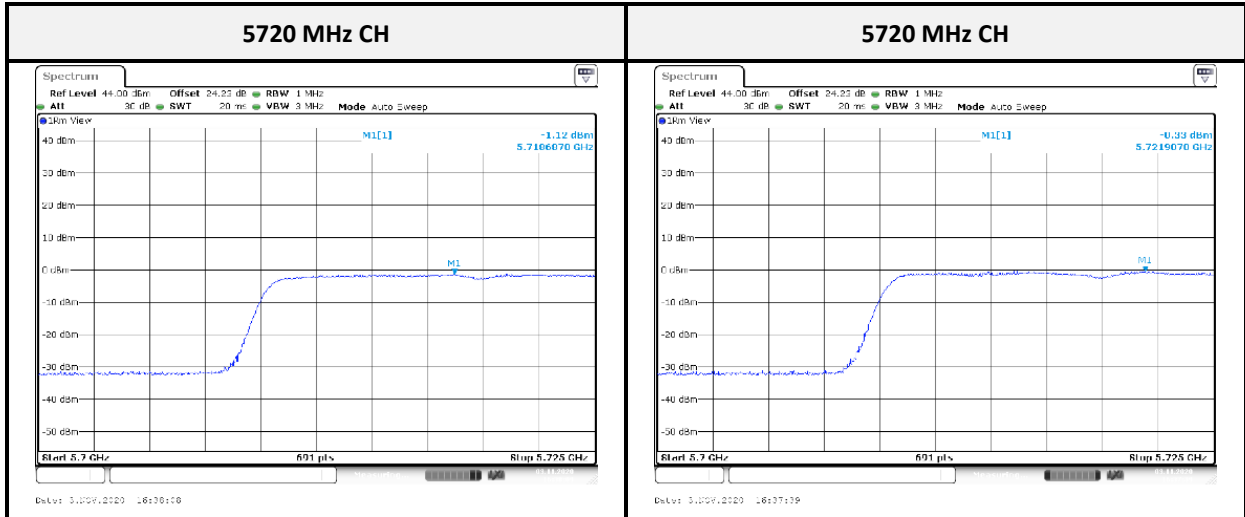

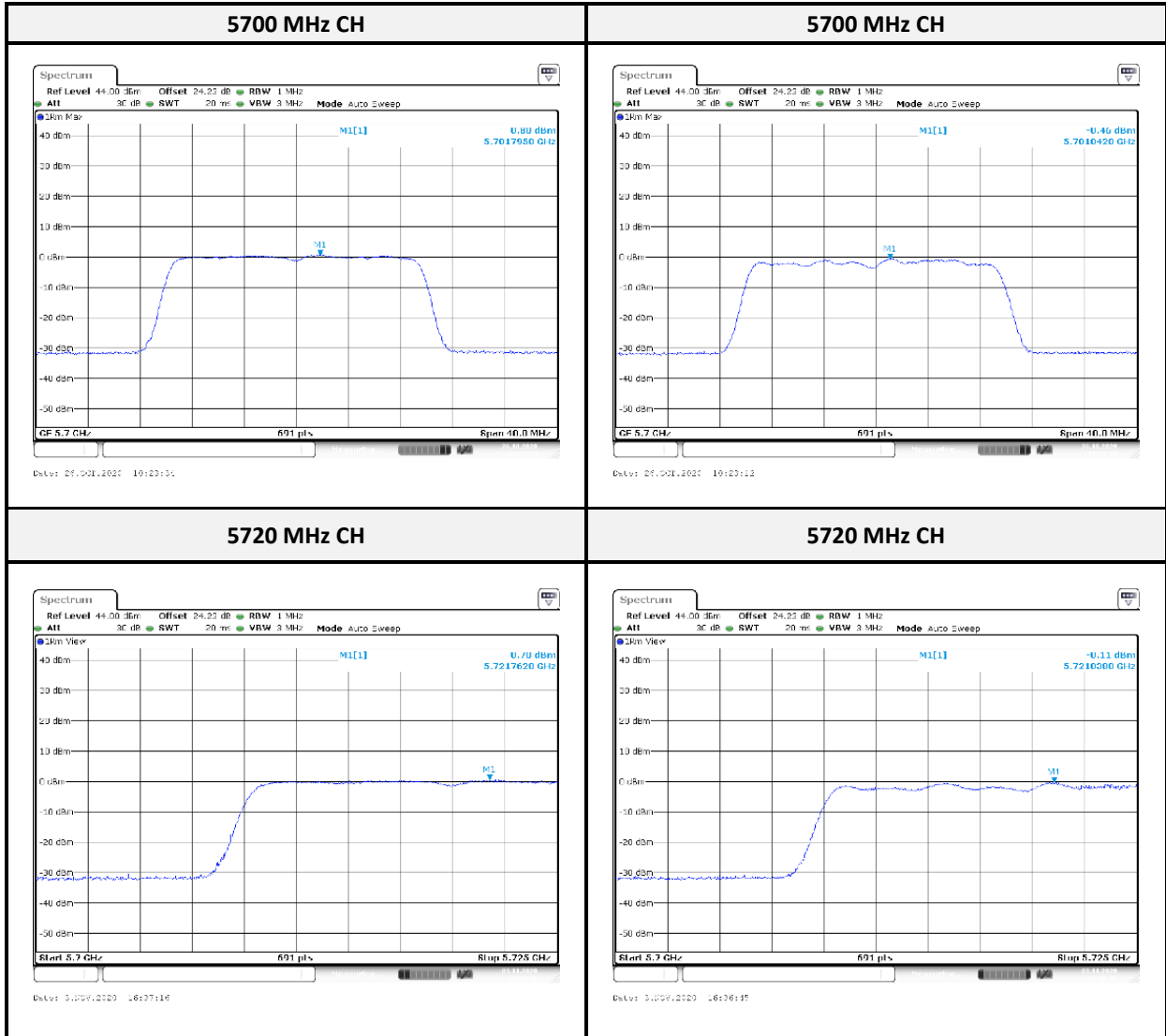

802.11ax HE40 mode:

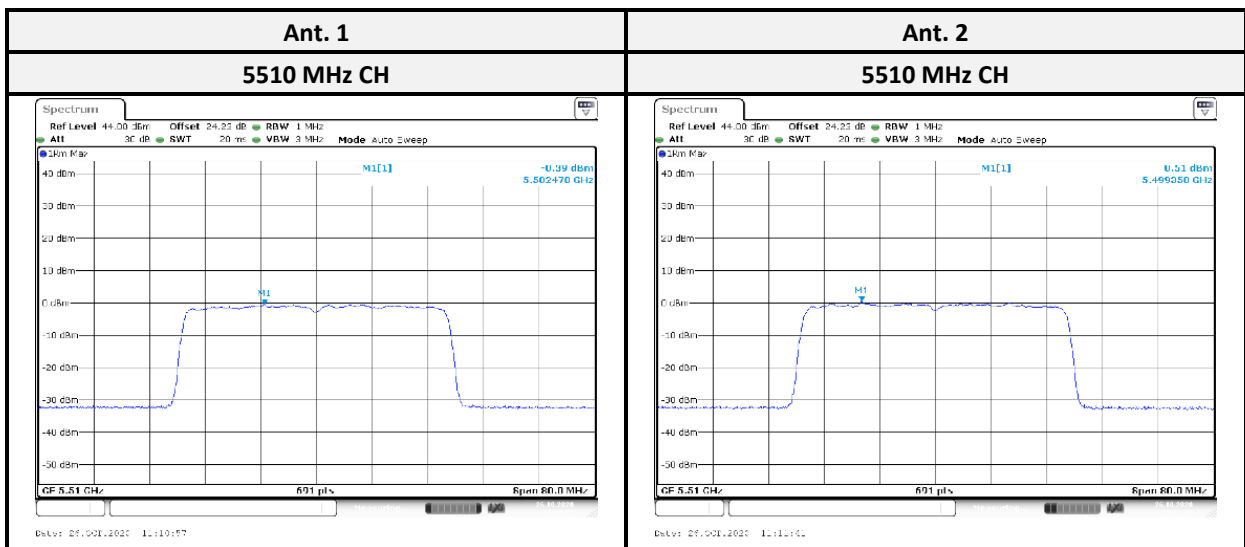

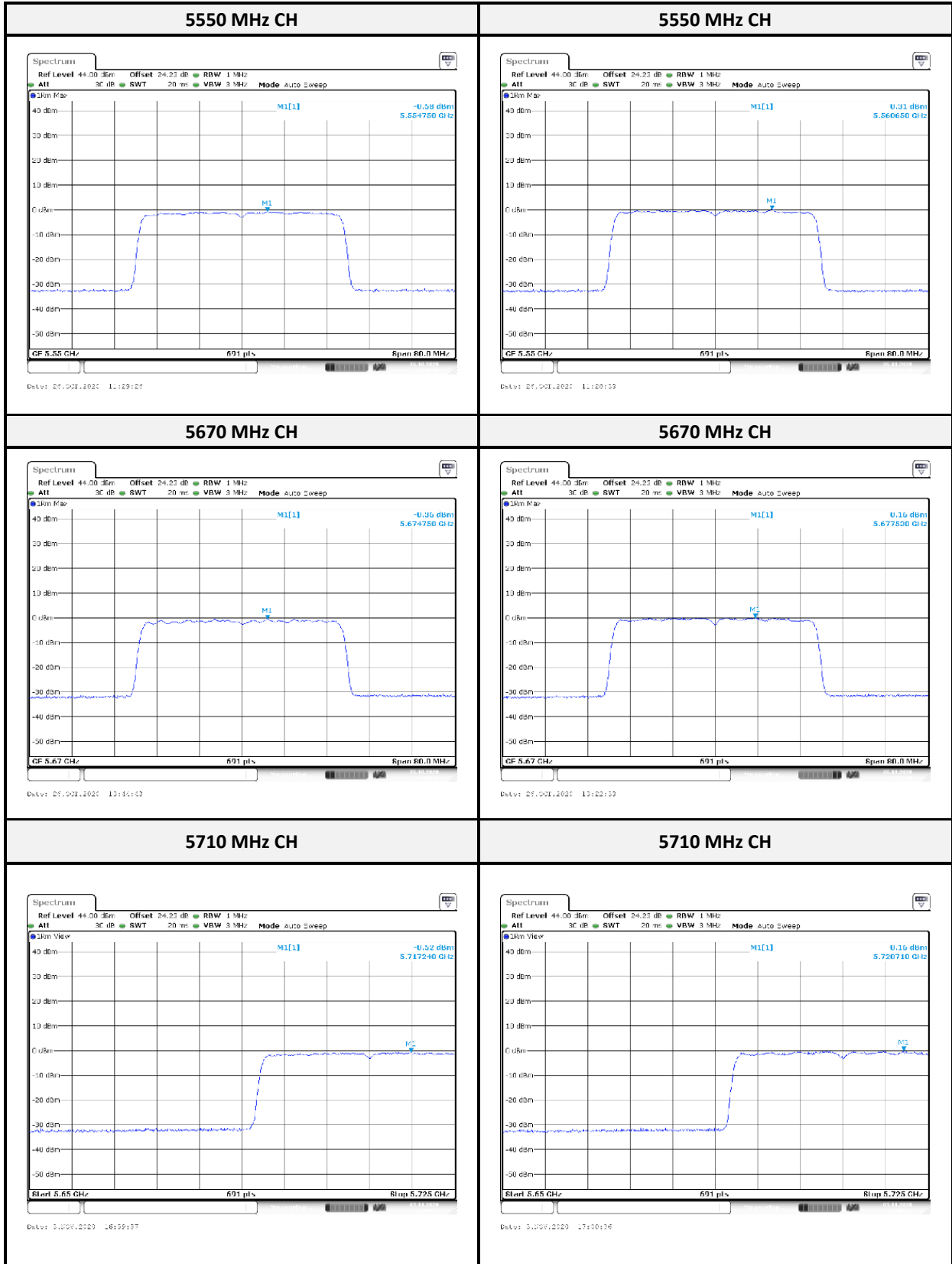

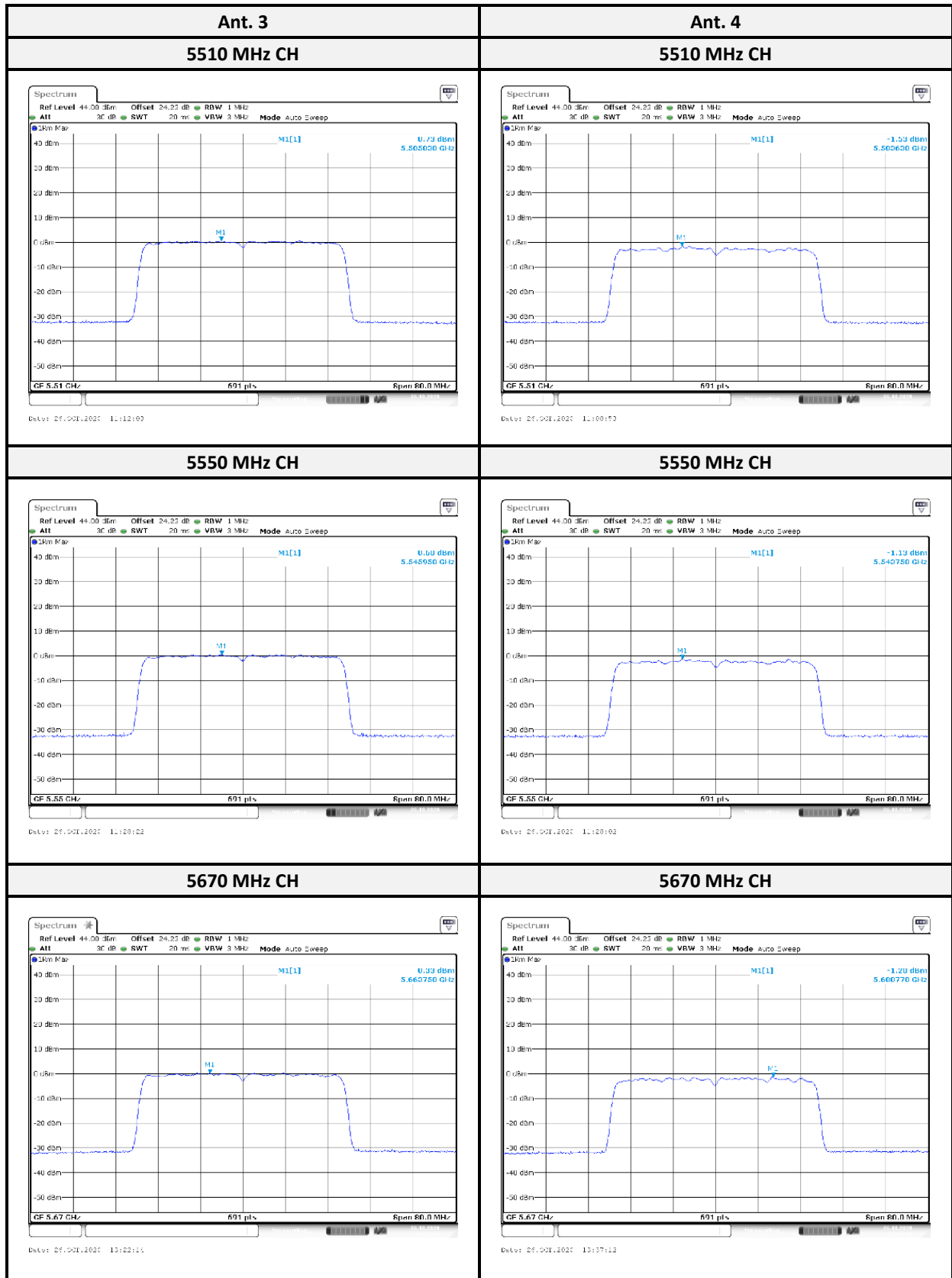

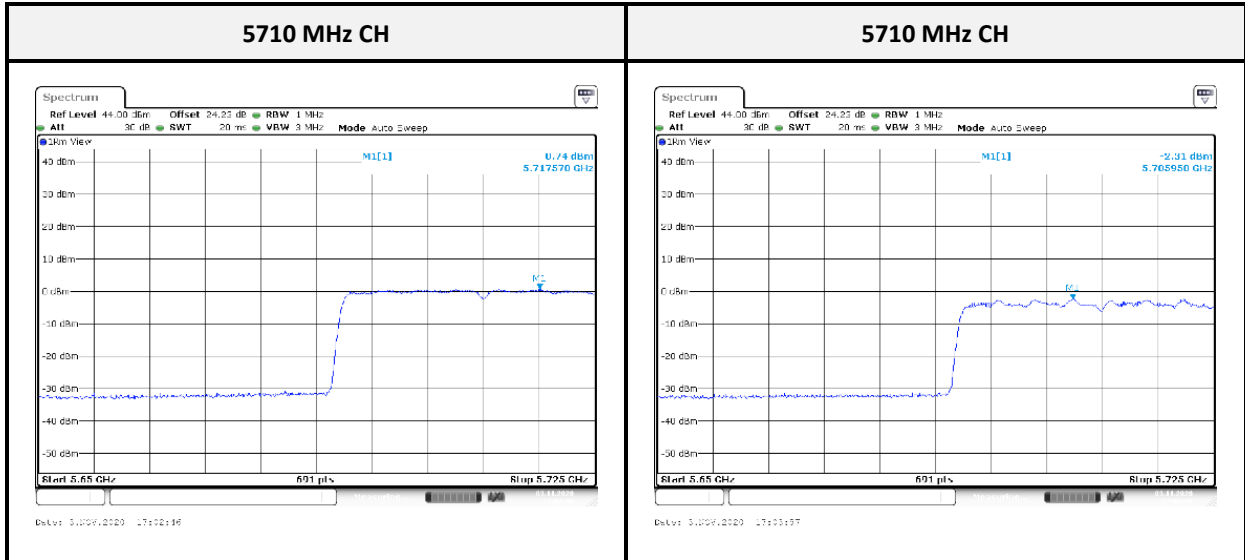

802.11ax HE80 mode:

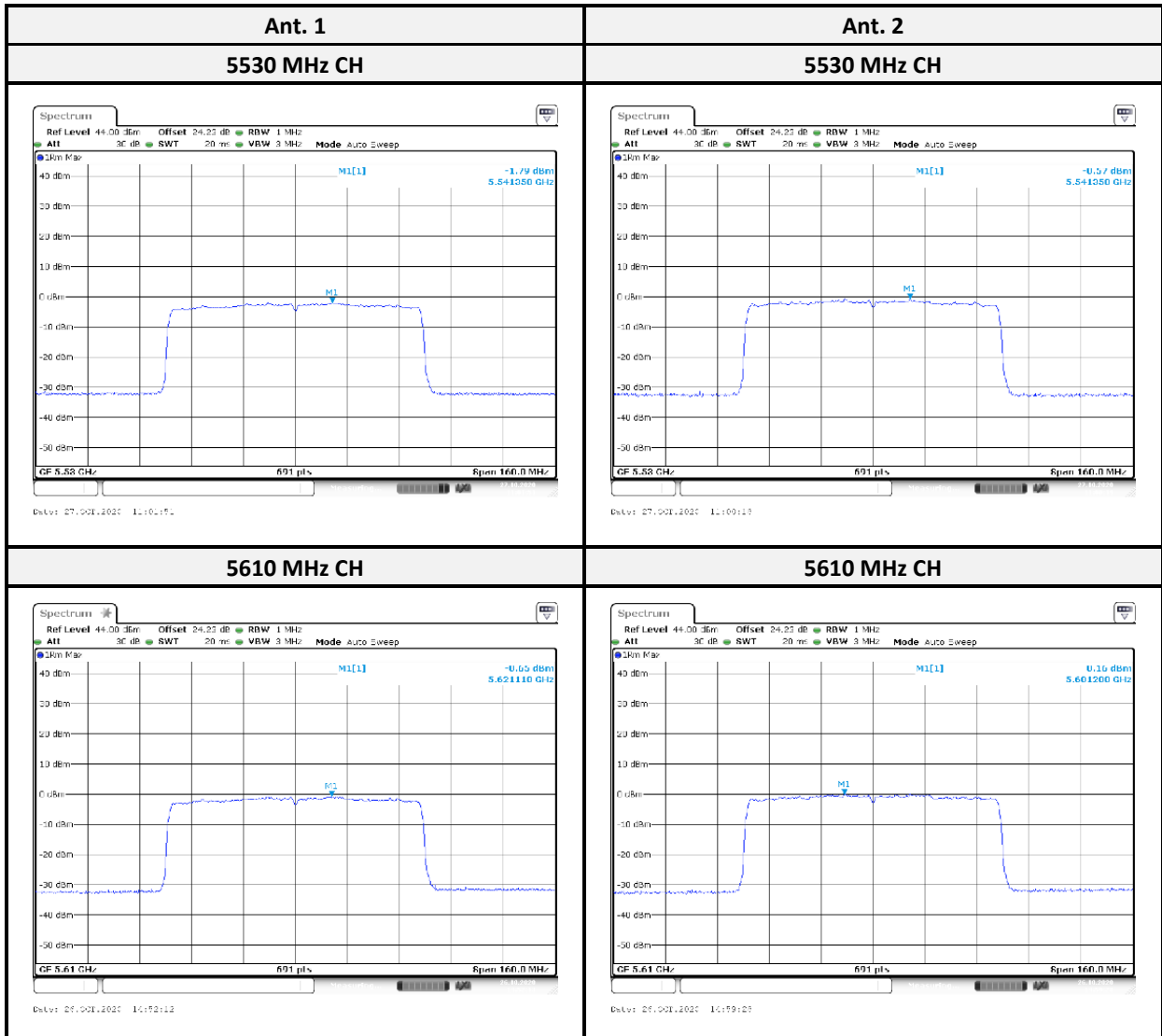

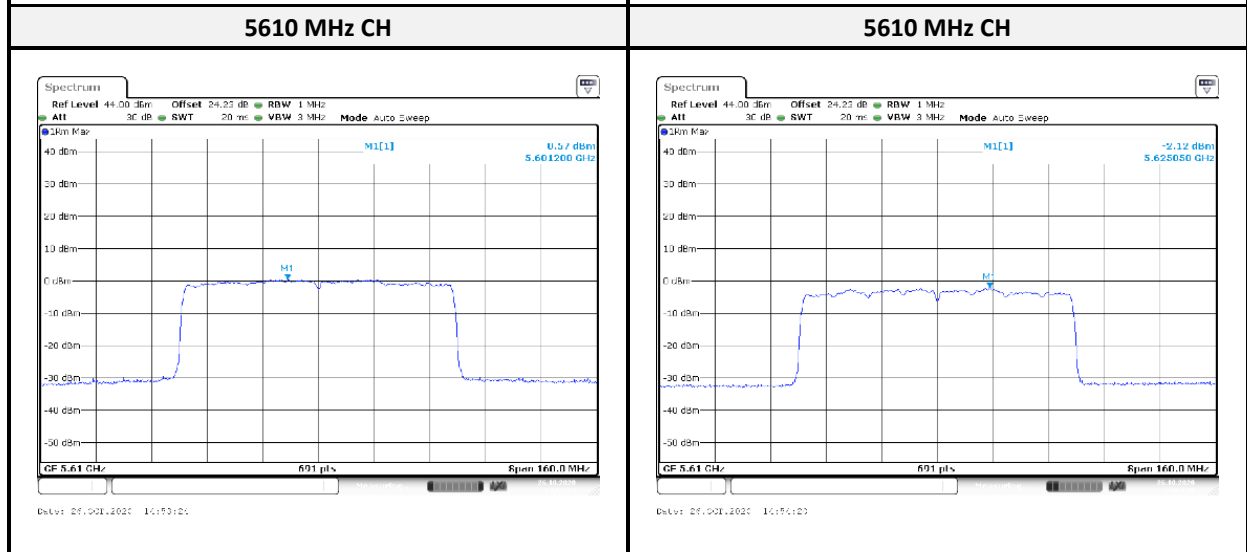
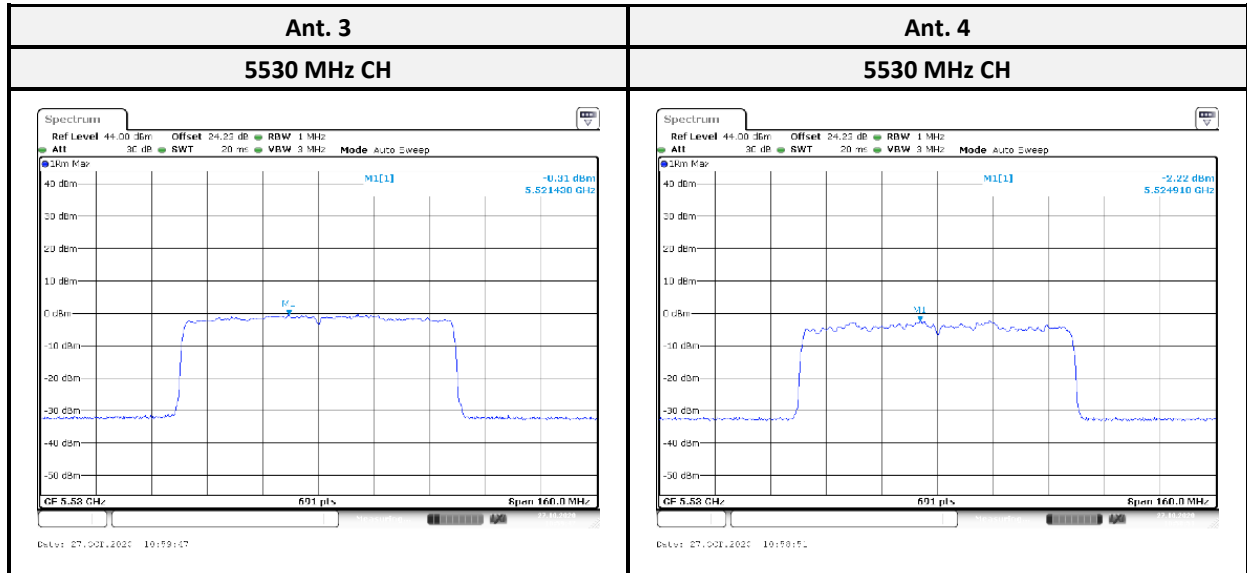
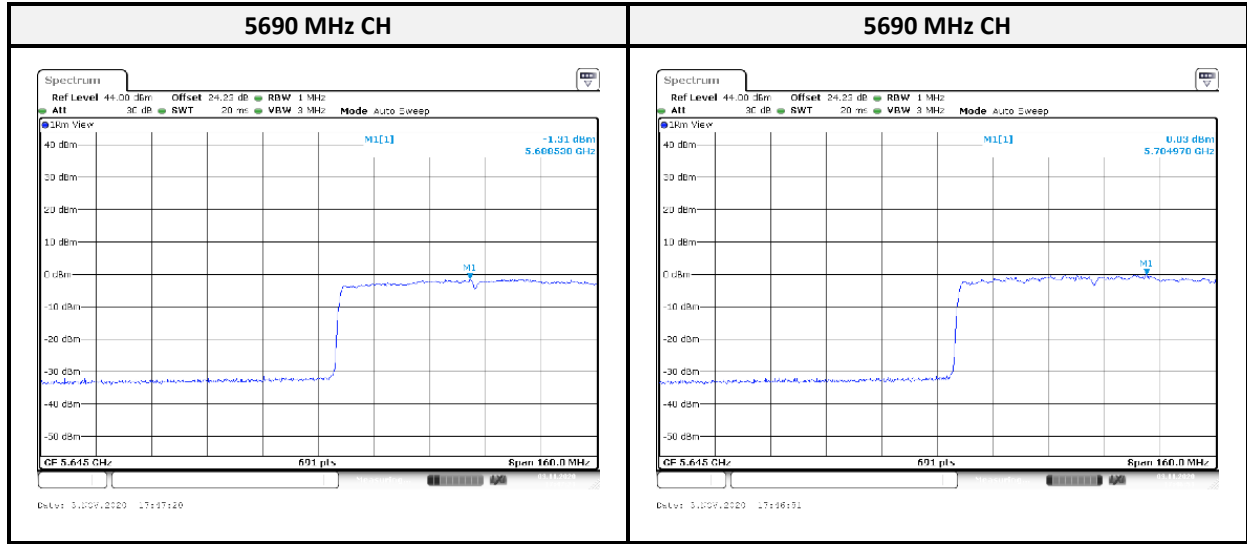

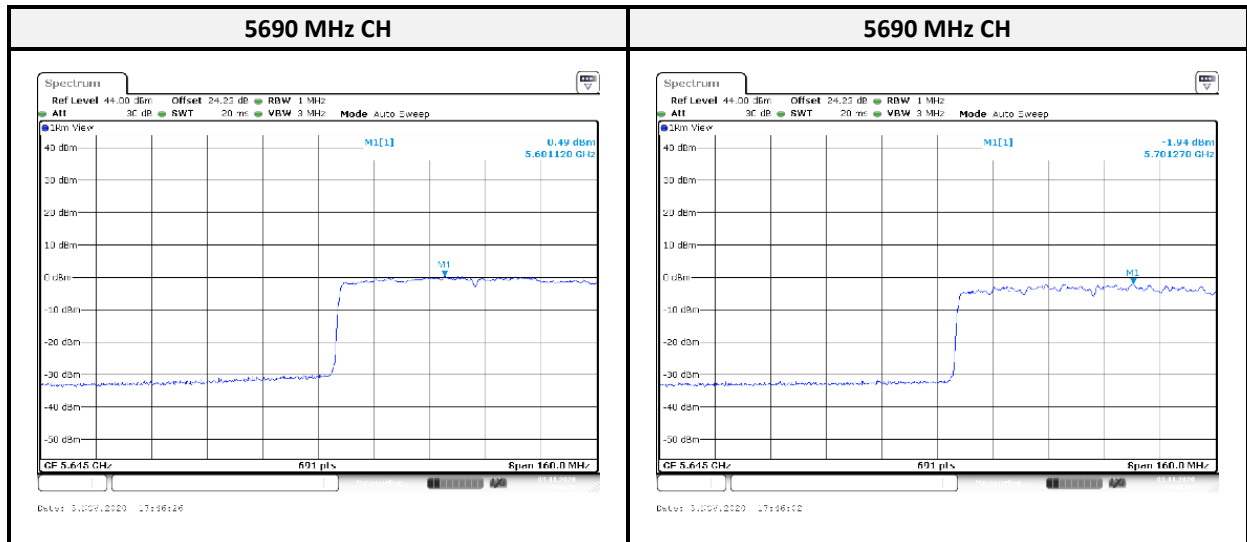

***** END OF REPORT *****