



# FCC RADIO TEST REPORT

## FCC ID: LNQSBWD60A

**Product :** ScreenBeam Mini2 Wireless Display Receiver

**Trade Name :** Actiontec

**Model Name :** SBWD60A

**Serial Model :** N/A

**Report No. :** NTEK-2014NT07091105F1

### Prepared for

Actiontec Electronics, Inc.

760 North Mary Ave., Sunnyvale, California 94085 United States

### Prepared by

Shenzhen NTEK Testing Technology Co., Ltd.

1/F, Building E, Fenda Science Park, Sanwei Community, Xixiang Street  
Bao'an District, Shenzhen P.R. China

Tel.: +86-0755-61156588 Fax.: +86-0755-61156599

Website: [www.ntek.org.cn](http://www.ntek.org.cn)

### TEST RESULT CERTIFICATION

**Applicant's name** ..... Actiontec Electronics, Inc.

Address ..... 760 North Mary Ave., Sunnyvale, California 94085 United States

**Manufacturer's Name**... Actiontec Electronics, Inc.

Address ..... 760 North Mary Ave., Sunnyvale, California 94085 United States

**Product description**

Product name ..... ScreenBeam Mini2 Wireless Display Receiver

Model and/or type  
reference ..... SBWD60A

Serial Model ..... N/A

**Standards** ..... FCC Part15.407 01 Oct. 2013

Test procedure ..... ANSI C63.4-2003 and KDB 789033 D01 v01r04

This device described above has been tested by NTEK, and the test results show that the equipment under test (EUT) is in compliance with the FCC requirements. And it is applicable only to the tested sample identified in the report.

This report shall not be reproduced except in full, without the written approval of NTEK, this document may be altered or revised by NTEK, personal only, and shall be noted in the revision of the document.

**Date of Test** .....

Date (s) of performance of tests ..... 09 Jul. 2014 ~26 Jul. 2014

Date of Issue..... 26 Jul. 2014

Test Result..... **Pass**

Testing Engineer :     Kyle Xu      
(Kyle Xu)

Technical Manager :     Brown Lu      
(Brown Lu)

Authorized Signatory :     Bill Yao      
(Bill Yao)

**Table of Contents**

	<b>Page</b>
<b>1 . SUMMARY OF TEST RESULTS</b>	<b>5</b>
1.1 TEST FACILITY	6
1.2 MEASUREMENT UNCERTAINTY	6
<b>2 . GENERAL INFORMATION</b>	<b>7</b>
2.1 GENERAL DESCRIPTION OF EUT	7
2.2 DESCRIPTION OF TEST MODES	10
2.3 BLOCK DIGRAM SHOWING THE CONFIGURATION OF SYSTEM TESTED	11
2.4 DESCRIPTION OF SUPPORT UNITS(CONDUCTED MODE)	12
2.5 EQUIPMENTS LIST FOR ALL TEST ITEMS	13
<b>3 . EMC EMISSION TEST</b>	<b>14</b>
3.1 CONDUCTED EMISSION MEASUREMENT	14
3.1.1 POWER LINE CONDUCTED EMISSION LIMITS	14
3.1.2 TEST PROCEDURE	15
3.1.3 DEVIATION FROM TEST STANDARD	15
3.1.4 TEST SETUP	15
3.1.5 EUT OPERATING CONDITIONS	15
3.1.6 TEST RESULTS	16
3.2 RADIATED EMISSION MEASUREMENT	20
3.2.1 RADIATED EMISSION LIMITS	20
3.2.2 TEST PROCEDURE	21
3.2.3 DEVIATION FROM TEST STANDARD	21
3.2.4 TEST SETUP	22
3.2.5 EUT OPERATING CONDITIONS	23
3.2.6 TEST RESULTS (BETWEEN 9KHZ – 30 MHZ)	24
3.2.7 TEST RESULTS (BETWEEN 30MHZ – 1GHZ)	25
3.2.8 TEST RESULTS (ABOVE 1000 MHZ)	27
<b>4 . POWER SPECTRAL DENSITY TEST</b>	<b>44</b>
4.1 APPLIED PROCEDURES / LIMIT	44
4.1.1 TEST PROCEDURE	44
4.1.2 DEVIATION FROM STANDARD	44
4.1.3 TEST SETUP	44
4.1.4 EUT OPERATION CONDITIONS	45
4.1.5 TEST RESULTS	46
<b>5 . 26 DB &amp; 99% EMISSION BANDWIDTH</b>	<b>57</b>
5.1 APPLIED PROCEDURES / LIMIT	57
5.1.1 TEST PROCEDURE	57

**Table of Contents**

	<b>Page</b>
5.1.2 EUT OPERATION CONDITIONS	57
5.1.3 TEST RESULTS	58
<b>6 . PEAK OUTPUT POWER TEST</b>	<b>69</b>
6.1 APPLIED PROCEDURES / LIMIT	69
6.1.1 TEST PROCEDURE	69
6.1.2 DEVIATION FROM STANDARD	69
6.1.3 TEST SETUP	69
6.1.4 EUT OPERATION CONDITIONS	69
6.1.5 TEST RESULTS	70
<b>7 . OUT OF BAND EMISSIONS</b>	<b>71</b>
7.1 DEVIATION FROM STANDARD	71
7.2 TEST SETUP	71
7.3 EUT OPERATION CONDITIONS	71
7.4 TEST RESULTS	72
<b>8 . PEAK EXCURSION RATIO</b>	<b>79</b>
8.1 APPLIED PROCEDURES / LIMIT	79
8.1.1 TEST PROCEDURE	79
8.1.2 DEVIATION FROM STANDARD	79
8.1.3 TEST SETUP	79
8.1.4 EUT OPERATION CONDITIONS	79
8.1.5 TEST RESULTS	80
<b>9 . ANTENNA REQUIREMENT</b>	<b>89</b>
9.1 STANDARD REQUIREMENT	89
9.2 EUT ANTENNA	89
<b>10 . EUT TEST PHOTO</b>	<b>90</b>
<b>APPENDIX-PHOTOGRAPHS OF EUT CONSTRUCTIONAL DETAILS</b>	

### 1. SUMMARY OF TEST RESULTS

Test procedures according to the technical standards:

FCC Part15 (15.407) , Subpart E			
Standard Section	Test Item	Judgment	Remark
FCC §15.207 IC RSS-Gen §7.2.4	AC Power Line Conducted Emissions	PASS	
FCC §15.209(a), 15.407(b) IC RSS-210 §A9.2	Spurious Radiated Emissions	PASS	
FCC §15.407(a) IC RSS-210 §A9.2	26 dB and 99% Emission Bandwidth	PASS	
FCC §407(a)(1) IC RSS-210 §A9.2	Peak Output Power Measurement	PASS	
FCC §2.1051, §15.407(b) IC RSS-210 §A9.2	Band Edges	PASS	
FCC §15.407(a)(1) IC RSS-210 §A9.2	Power Spectral Density	PASS	
FCC §15.407(a)(6)	Peak Excursion Ratio	PASS	
IC RSS-210 §2.3 IC RSS-Gen §6.1	Receiver Spurious Radiated Emissions	PASS	
FCC §2.1051, §15.407(b) IC RSS-210 §A9.2	Spurious Emissions at Antenna Terminals	PASS	
FCC §15.203 IC RSS-Gen §7.1.2	Antenna Requirement	PASS	

**NOTE:**

(1) "N/A" denotes test is not applicable in this Test Report

**1.1 TEST FACILITY**

NTEK Testing Technology Co., Ltd  
 Add.:1/F, Building E, Fenda Science Park, Sanwei Community, Xixiang Street, Bao'an District, Shenzhen P.R. China.  
 FCC Registration No.:238937; IC Registration No.:9270A-1  
 CNAS Registration No.:L5516

**1.2 MEASUREMENT UNCERTAINTY**

The reported uncertainty of measurement  $y \pm U$ , where expanded uncertainty  $U$  is based on a standard uncertainty multiplied by a coverage factor of  $k=2$ , providing a level of confidence of approximately 95 %.

No.	Item	Uncertainty
1	Conducted Emission Test	$\pm 1.38\text{dB}$
2	RF power,conducted	$\pm 0.16\text{dB}$
3	Spurious emissions,conducted	$\pm 0.21\text{dB}$
4	All emissions,radiated(<1G)	$\pm 4.68\text{dB}$
5	All emissions,radiated(>1G)	$\pm 4.89\text{dB}$
6	Temperature	$\pm 0.5^\circ\text{C}$
7	Humidity	$\pm 2\%$

## 2. GENERAL INFORMATION

### 2.1 GENERAL DESCRIPTION OF EUT

Equipment	ScreenBeam Mini2 Wireless Display Receiver	
Trade Name	Actiontec	
Model Name	SBWD60A	
Product Description	The EUT is a ScreenBeam Mini2 Wireless Display Receiver	
	Operation Frequency:	802.11a/n(20):5180 MHz ~ 5240 MHz 802.11n(40): 5190 MHz ~ 5230 MHz
	Modulation Type:	OFDM (BPSK / QPSK / 16QAM / 64QAM)
	Bit Rate of Transmitter	802.11a:54/48/36/24/18/12/9/6Mbps 802.11n(20MHz):150/144.44/130/117/115.56/104/86.67/78/52/6.5Mbps 802.11n(40MHz):300/270/240/180/150/120/108/90/54 Mbps
	Number Of Channel	802.11a/n20MHz:7CH 802.11n40MHz:5CH
	Max.Output Power(Conducted):	12.31 dBm
	Antenna Designation:	Please see Note 3.
	Antenna Gain (dBi)	Please see Note 3.
	Based on the application, features, or specification exhibited in User's Manual, the EUT is considered as an ITE/Computing Device. More details of EUT technical specification, please refer to the User's Manual.	
Channel List	Please refer to the Note 2.	
Ratings	Adapter 1: DC 5V,1.0A Adapter 2: DC 5V,1000mA	
Adapter	Adapter 1: Mode: MU05B2050100-A1 Input: 100-240V~, 50/60Hz, 0.3A Output: 5V $\overline{\text{---}}$ , 1.0A Adapter 2: Mode: SC050100-US Input: 100-240V~, 50/60Hz, 0.4A Output: 5V $\overline{\text{---}}$ , 1000mA	
Battery	N/A	

Note:

1. For a more detailed features description, please refer to the manufacturer's specifications or the User's Manual.

2.  
5GHz

802.11a/n(20)Carrier Frequency Channel							
Channel	Frequency (MHz)	Channel	Frequency (MHz)	Channel	Frequency (MHz)	Channel	Frequency (MHz)
36	5180	38	5190	40	5200	42	5210
44	5220	46	5230	48	5240	-	-

802.11n (BW40MHz) Carrier Frequency Channel							
Channel	Frequency (MHz)	Channel	Frequency (MHz)	Channel	Frequency (MHz)	Channel	Frequency (MHz)
38	5190	40	5200	42	5210	44	5220
46	5230	-	-	-	-	-	-

3.  
Table for Filed Antenna

Ant	Brand	Model Name	Antenna Type	Gain (dBi)	NOTE
A	N/A	N/A	PCB antenna	2.4G/5G:6.05	Wifi Antenna
B	N/A	N/A	PCB antenna	2.4G/5G:6.05	Wifi Antenna



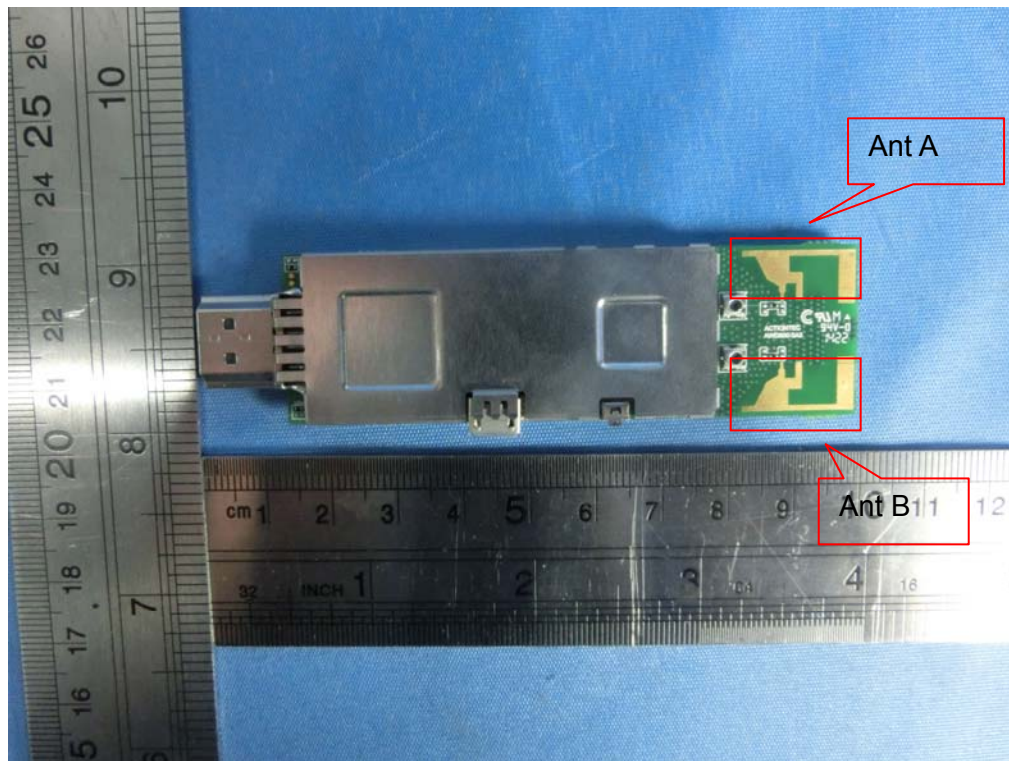

The Control software(tool\_WIFI.exe) can control antenna A B ,  
 For 2.4GHz mode, antenna A B are transmitting,two antennas simultaneously transmit.  
 And the data is recorded for radiated emission and band edge.  
 For 5GHz mode,antenna A B are transmitting Two antennas simultaneously transmit.  
 And the data is recorded for radiated emission, and band edge.  
 For MIMO mode , Directional gain= $G_{ANT} + 10\log(N)$ dbi =9.06dbi in 2.4GHz  
 Directional gain= $G_{ANT} + 10\log(N)$ dbi =9.06dbi in 5GHz  
 802.11a/b/g/n 2.4GHz & 5GHz has MIMO mode.

## 2.2 DESCRIPTION OF TEST MODES

To investigate the maximum EMI emission characteristics generates from EUT, the test system was pre-scanning tested base on the consideration of following EUT operation mode or test configuration mode which possible have effect on EMI emission level. Each of these EUT operation mode(s) or test configuration mode(s) mentioned above was evaluated respectively.

Pretest Mode	Description
Mode 1	802.11a /n CH36/ CH40/ CH 48
Mode 2	802.11n38/ CH 46
Mode 3	Link Mode

For Conducted Emission	
Final Test Mode	Description
Mode 3	Link Mode

For Radiated Emission	
Final Test Mode	Description
Mode 1	802.11a /n CH36/ CH40/ CH 48
Mode 2	802.11n38/ CH 46
Mode 3	Link Mode

Note:

- (1) The measurements are performed at the highest, middle, lowest available channels.
- (2) The measurements are performed at all Bit Rate of Transmitter, the worst data was reported

### 2.3 BLOCK DIGRAM SHOWING THE CONFIGURATION OF SYSTEM TESTED

Conducted Emission Test

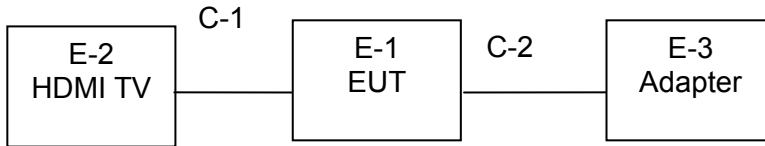

Radiated Emission Test

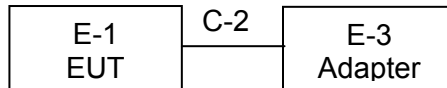

**2.4 DESCRIPTION OF SUPPORT UNITS(CONDUCTED MODE)**

The EUT has been tested as an independent unit together with other necessary accessories or support units. The following support units or accessories were used to form a representative test configuration during the tests.

Item	Equipment	Brand	Model/Type No.	Series No.	Note
E-1	ScreenBeam Mini2 Wireless Display Receiver	Actiontec	SBWD60A	N/A	EUT
E-2	TV	SONY	KDL-24EX520	N/A	
E-3	Adapter 1	Actiontec	MU05B2050100-A1	N/A	
E-3	Adapter 2	Actiontec	SC050100-US	N/A	

Item	Shielded Type	Ferrite Core	Length	Note
C-1	NO	NO	100cm	
C-2	NO	NO	80cm	

Note:

- (1) The support equipment was authorized by Declaration of Confirmation.
- (2) For detachable type I/O cable should be specified the length in cm in 『Length』 column.

**2.5 EQUIPMENTS LIST FOR ALL TEST ITEMS**

Radiation Test equipment

Item	Kind of Equipment	Manufacturer	Type No.	Serial No.	Last calibration	Calibrated until	Calibration period
1	Spectrum Analyzer	Agilent	E4407B	MY45108040	2014.07.06	2015.07.05	1 year
2	Test Receiver	R&S	ESPI	101318	2014.06.07	2015.06.06	1 year
3	Bilog Antenna	TESEQ	CBL6111D	31216	2014.07.06	2015.07.05	1 year
4	50Ω Coaxial Switch	Anritsu	MP59B	6200264416	2014.06.07	2015.06.06	1 year
5	Spectrum Analyzer	ADVANTEST	R3132	150900201	2014.06.07	2015.06.06	1 year
6	Horn Antenna	EM	EM-AH-10180	2011071402	2014.07.06	2015.07.05	1 year
7	Horn Ant	Schwarzbeck	BBHA 9170	9170-181	2014.07.06	2015.07.05	1 year
8	Amplifier	EM	EM-30180	060538	2013.12.22	2014.12.21	1 year
9	Loop Antenna	ARA	PLA-1030/B	1029	2014.06.07	2015.06.06	1 year
10	Power Meter	R&S	NRVS	100696	2014.07.06	2015.07.05	1 year
11	Power Sensor	R&S	URV5-Z4	0395.1619.05	2014.07.06	2015.07.05	1 year

Conduction Test equipment

Item	Kind of Equipment	Manufacturer	Type No.	Serial No.	Last calibration	Calibrated until	Calibration period
1	Test Receiver	R&S	ESCI	101160	2014.06.07	2015.06.06	1 year
2	LISN	R&S	ENV216	101313	2013.08.24	2014.08.23	1 year
3	LISN	EMCO	3816/2	00042990	2013.08.24	2014.08.23	1 year
4	50Ω Coaxial Switch	Anritsu	MP59B	6200264417	2014.06.07	2015.06.06	1 year
5	Passive Voltage Probe	R&S	ESH2-Z3	100196	2014.06.07	2015.06.06	1 year
6	Absorbing clamp	R&S	MOS-21	100423	2014.06.07	2015.06.06	1 year

1	Attenuation	MCE	24-10-34	BN9258	2014.06.07	2015.06.06	1 year
---	-------------	-----	----------	--------	------------	------------	--------

### 3. EMC EMISSION TEST

#### 3.1 CONDUCTED EMISSION MEASUREMENT

##### 3.1.1 POWER LINE CONDUCTED EMISSION Limits (Frequency Range 150KHz-30MHz)

FREQUENCY (MHz)	Class A (dBuV)		Class B (dBuV)		Standard
	Quasi-peak	Average	Quasi-peak	Average	
0.15 -0.5	79.00	66.00	66 - 56 *	56 - 46 *	CISPR
0.50 -5.0	73.00	60.00	56.00	46.00	CISPR
5.0 -30.0	73.00	60.00	60.00	50.00	CISPR

0.15 -0.5	79.00	66.00	66 - 56 *	56 - 46 *	FCC
0.50 -5.0	73.00	60.00	56.00	46.00	FCC
5.0 -30.0	73.00	60.00	60.00	50.00	FCC

Note:

- (1) The tighter limit applies at the band edges.
- (2) The limit of " \* " marked band means the limitation decreases linearly with the logarithm of the frequency in the range.

The following table is the setting of the receiver

Receiver Parameters	Setting
Attenuation	10 dB
Start Frequency	0.15 MHz
Stop Frequency	30 MHz
IF Bandwidth	9 kHz

**3.1.2 TEST PROCEDURE**

- a. The EUT was placed 0.8 meters from the horizontal ground plane with EUT being connected to the power mains through a line impedance stabilization network (LISN). All other support equipments powered from additional LISN(s). The LISN provide 50 Ohm/ 50uH of coupling impedance for the measuring instrument.
- b. Interconnecting cables that hang closer than 40 cm to the ground plane shall be folded back and forth in the center forming a bundle 30 to 40 cm long.
- c. I/O cables that are not connected to a peripheral shall be bundled in the center. The end of the cable may be terminated, if required, using the correct terminating impedance. The overall length shall not exceed 1 m.
- d. LISN at least 80 cm from nearest part of EUT chassis.
- e. For the actual test configuration, please refer to the related Item –EUT Test Photos.

**3.1.3 DEVIATION FROM TEST STANDARD**

No deviation

**3.1.4 TEST SETUP**

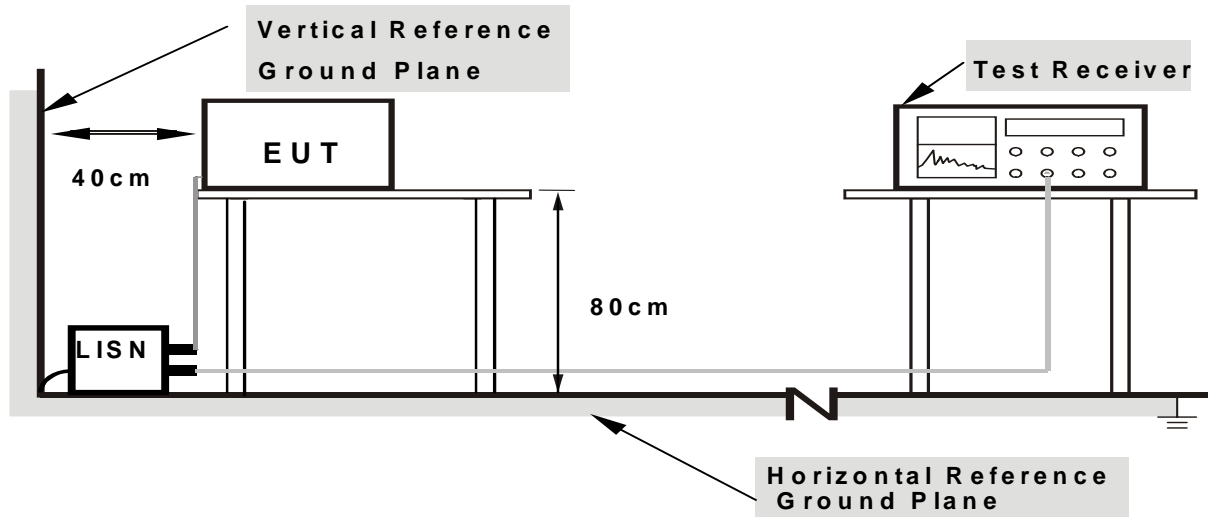

- Note:**
- 1. Support units were connected to second LISN.
  - 2. Both of LISNs (AMN) are 80 cm from EUT and at least 80 from other units and other metal planes

**3.1.5 EUT OPERATING CONDITIONS**

The EUT was configured for testing in a typical fashion (as a customer would normally use it). The EUT has been programmed to continuously transmit during test. This operating condition was tested and used to collect the included data.

### 3.1.6 TEST RESULTS

EUT :	ScreenBeam Mini2 Wireless Display Receiver	Model Name. :	SBWD60A
Temperature :	26 °C	Relative Humidity :	56%
Pressure :	1010hPa	Phase :	L
Test Voltage :	DC 5V From adapter AC120V/60Hz- Adapter 1	Test Mode :	Mode 3

Frequency (MHz)	Meter Reading (dBμV)	Factor (dB)	Emission Level (dBμV)	Limits (dBμV)	Margin (dB)	Remark
0.1580	40.62	9.63	50.25	65.56	-15.31	QP
0.1580	26.21	9.63	35.84	55.56	-19.72	AVG
0.1980	39.07	9.51	48.58	63.69	-15.11	QP
0.1980	24.02	9.51	33.53	53.69	-20.16	AVG
0.5899	39.03	9.53	48.56	56.00	-7.44	QP
0.5899	25.81	9.53	35.34	46.00	-10.66	AVG
0.8059	31.30	9.54	40.84	56.00	-15.16	QP
0.8059	19.50	9.54	29.04	46.00	-16.96	AVG
1.1300	30.64	9.55	40.19	56.00	-15.81	QP
1.1300	17.99	9.55	27.54	46.00	-18.46	AVG
13.6019	37.66	9.81	47.47	60.00	-12.53	QP
13.6019	23.79	9.81	33.60	50.00	-16.40	AVG

**Remark:**

1. All readings are Quasi-Peak and Average values.
2. Factor = Insertion Loss + Cable Loss.

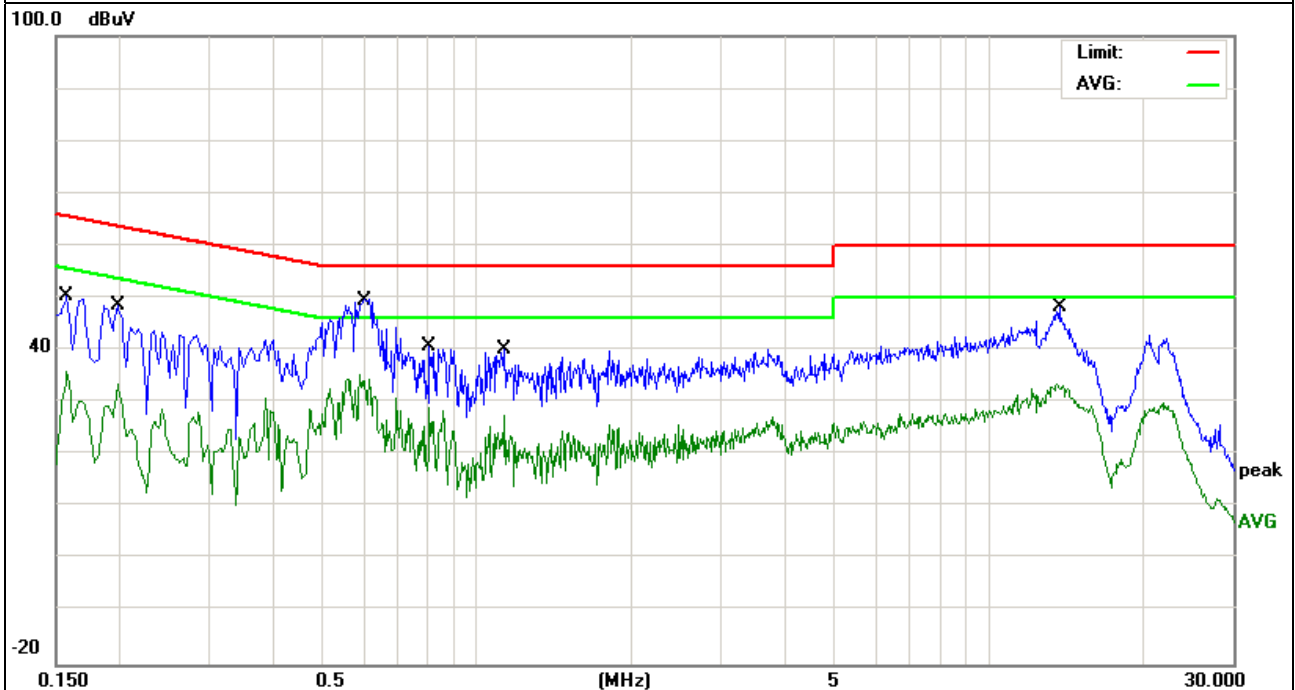



EUT :	ScreenBeam Mini2 Wireless Display Receiver	Model Name. :	SBWD60A
Temperature :	26 °C	Relative Humidity :	56%
Pressure :	1010hPa	Phase :	N
Test Voltage :	DC 5V From adapter AC120V/60Hz- Adapter 1	Test Mode :	Mode 3

Frequency (MHz)	Meter Reading (dBμV)	Factor (dB)	Emission Level (dBμV)	Limits (dBμV)	Margin (dB)	Remark
0.1819	39.32	9.56	48.88	64.39	-15.51	QP
0.1819	26.40	9.56	35.96	54.39	-18.43	AVG
0.5100	37.75	9.53	47.28	56.00	-8.72	QP
0.5100	29.83	9.53	39.36	46.00	-6.64	AVG
0.5898	41.42	9.53	50.95	56.00	-5.05	QP
0.5898	31.34	9.53	40.87	46.00	-5.13	AVG
1.2257	29.04	9.55	38.59	56.00	-17.41	QP
1.2257	19.86	9.55	29.41	46.00	-16.59	AVG
2.6218	28.27	9.57	37.84	56.00	-18.16	QP
2.6218	19.95	9.57	29.52	46.00	-16.48	AVG
13.7659	36.73	9.82	46.55	60.00	-13.45	QP
13.7659	23.77	9.82	33.59	50.00	-16.41	AVG

Remark:  
 1. All readings are Quasi-Peak and Average values.  
 2. Factor = Insertion Loss + Cable Loss.

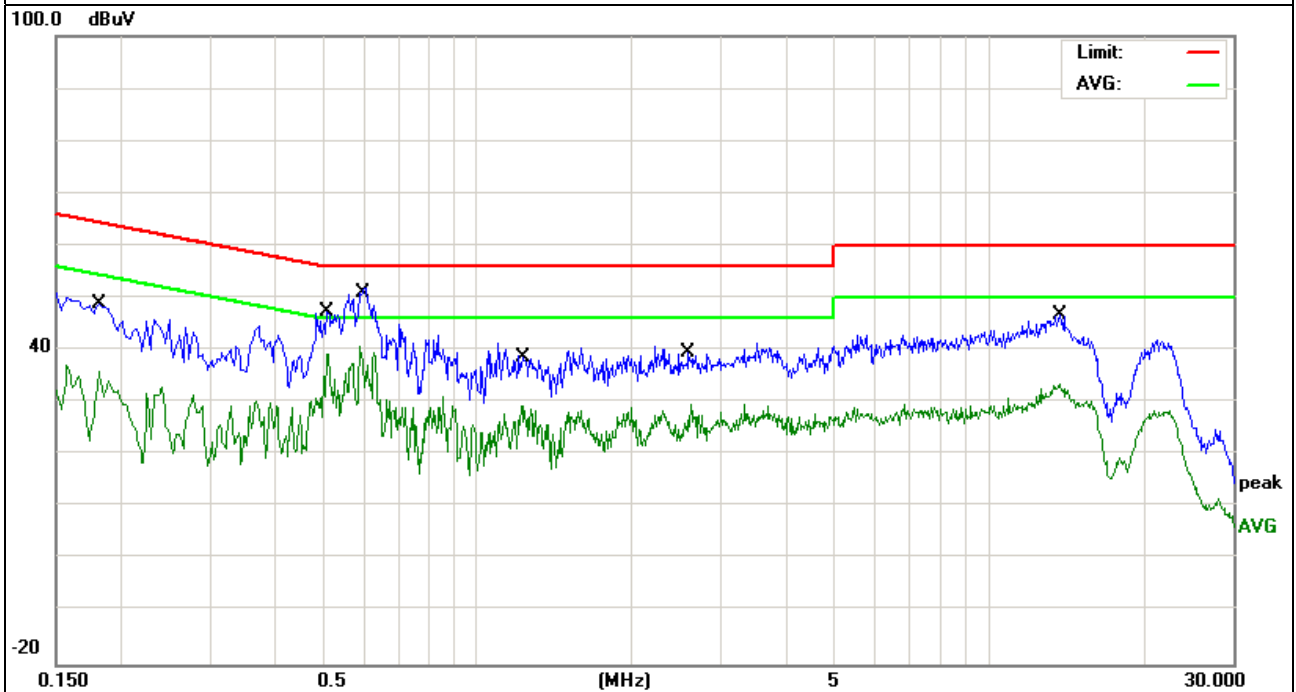

EUT :	ScreenBeam Mini2 Wireless Display Receiver	Model Name. :	SBWD60A
Temperature :	26 °C	Relative Humidity :	56%
Pressure :	1010hPa	Phase :	L
Test Voltage :	DC 5V From adapter AC120V/60Hz- Adapter 2	Test Mode :	Mode 3

Frequency (MHz)	Meter Reading (dBμV)	Factor (dB)	Emission Level (dBμV)	Limits (dBμV)	Margin (dB)	Remark
0.1620	44.56	9.62	54.18	65.36	-11.18	QP
0.1620	28.53	9.62	38.15	55.36	-17.21	AVG
0.3780	37.08	9.52	46.60	58.32	-11.72	QP
0.3780	26.06	9.52	35.58	48.32	-12.74	AVG
0.4180	39.57	9.52	49.09	57.49	-8.40	QP
0.4180	32.70	9.52	42.22	47.49	-5.27	AVG
0.8380	34.66	9.54	44.20	56.00	-11.80	QP
0.8380	23.59	9.54	33.13	46.00	-12.87	AVG
5.1979	33.02	9.60	42.62	60.00	-17.38	QP
5.1979	22.74	9.60	32.34	50.00	-17.66	AVG
13.1139	33.06	9.81	42.87	60.00	-17.13	QP
13.1139	22.03	9.81	31.84	50.00	-18.16	AVG

Remark:

1. All readings are Quasi-Peak and Average values.
2. Factor = Insertion Loss + Cable Loss.

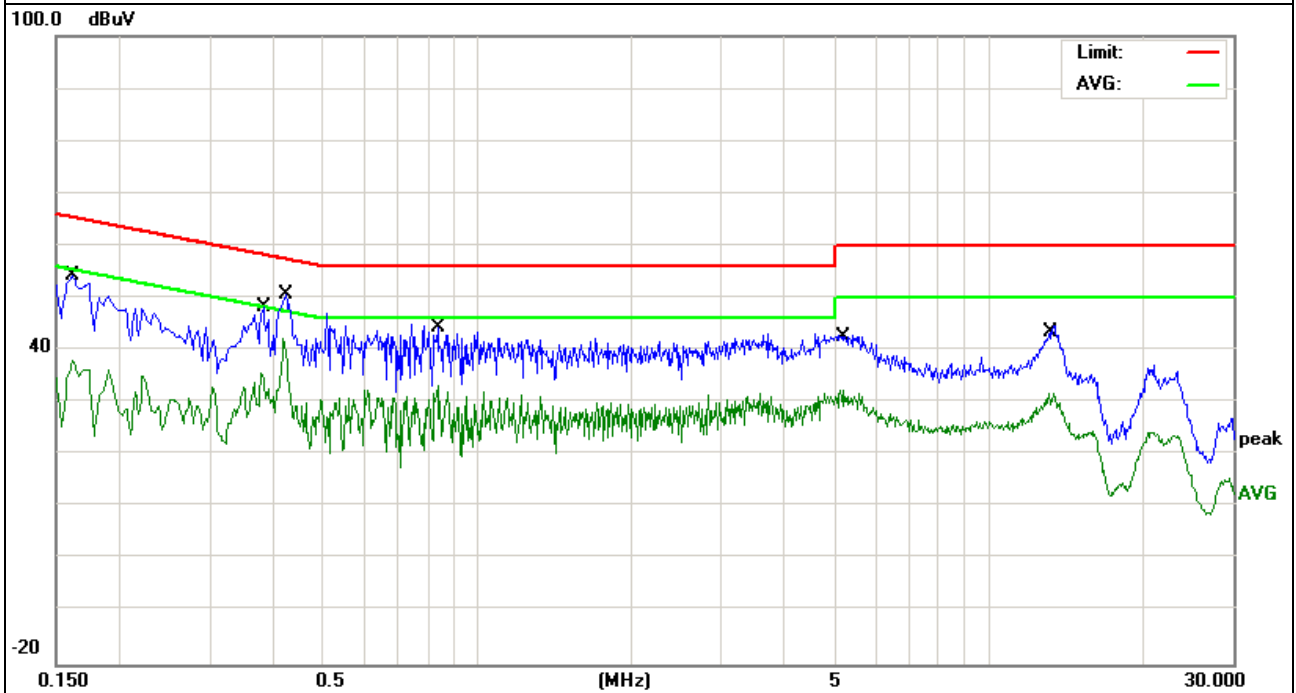

EUT :	ScreenBeam Mini2 Wireless Display Receiver	Model Name. :	SBWD60A
Temperature :	26 °C	Relative Humidity :	56%
Pressure :	1010hPa	Phase :	N
Test Voltage :	DC 5V From adapter AC120V/60Hz- Adapter 2	Test Mode :	Mode 3

Frequency (MHz)	Meter Reading (dBμV)	Factor (dB)	Emission Level (dBμV)	Limits (dBμV)	Margin (dB)	Remark
0.1739	41.38	9.58	50.96	64.77	-13.81	QP
0.1739	27.64	9.58	37.22	54.77	-17.55	AVG
0.4139	42.45	9.52	51.97	57.57	-5.60	QP
0.4139	32.16	9.52	41.68	47.57	-5.89	AVG
0.5540	37.52	9.53	47.05	56.00	-8.95	QP
0.5540	27.59	9.53	37.12	46.00	-8.88	AVG
1.0660	37.53	9.55	47.08	56.00	-8.92	QP
1.0660	25.67	9.55	35.22	46.00	-10.78	AVG
4.9739	34.30	9.60	43.90	56.00	-12.10	QP
4.9739	23.47	9.60	33.07	46.00	-12.93	AVG
13.4338	34.78	9.81	44.59	60.00	-15.41	QP
13.4338	22.25	9.81	32.06	50.00	-17.94	AVG

Remark:

1. All readings are Quasi-Peak and Average values.
2. Factor = Insertion Loss + Cable Loss.

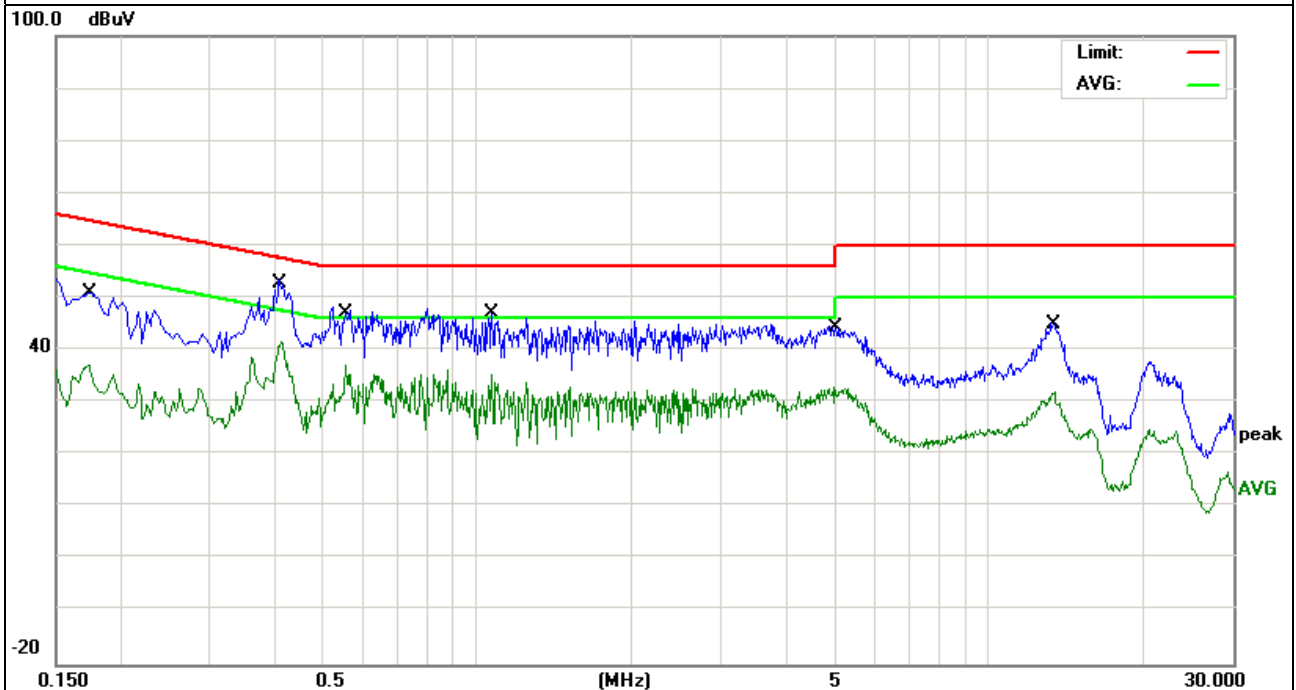

### 3.2 RADIATED EMISSION MEASUREMENT

#### 3.2.1 RADIATED EMISSION LIMITS (Frequency Range 9kHz-1000MHz)

20dBc in any 100 kHz bandwidth outside the operating frequency band. In case the emission fall within the restricted band specified on 15.205(a), then the 15.209(a) limit in the table below has to be followed.

Frequencies (MHz)	Field Strength (microrvolts/meter)	Measurement Distance (meters)
0.009~0.490	2400/F(KHz)	300
0.490~1.705	24000/F(KHz)	30
1.705~30.0	30	30
30~88	100	3
88~216	150	3
216~960	200	3
Above 960	500	3

#### LIMITS OF RADIATED EMISSION MEASUREMENT (Above 1000MHz)

FREQUENCY (MHz)	Class A (dBuV/m) (at 3M)		Class B (dBuV/m) (at 3M)	
	PEAK	AVERAGE	PEAK	AVERAGE
Above 1000	80	60	74	54

Notes:

- (1) The limit for radiated test was performed according to FCC PART 15C.
- (2) The tighter limit applies at the band edges.
- (3) Emission level (dBuV/m)=20log Emission level (uV/m).

Spectrum Parameter	Setting
Attenuation	Auto
Start Frequency	1000 MHz
Stop Frequency	10th carrier harmonic
RB / VB (emission in restricted band)	1 MHz / 1 MHz for Peak, 1 MHz / 10Hz for Average

Receiver Parameter	Setting
Attenuation	Auto
Start ~ Stop Frequency	9kHz~150kHz / RB 200Hz for QP
Start ~ Stop Frequency	150kHz~30MHz / RB 9kHz for QP
Start ~ Stop Frequency	30MHz~1000MHz / RB 120kHz for QP

### 3.2.2 TEST PROCEDURE

- a. The measuring distance of at 3 m shall be used for measurements at frequency up to 1GHz. For frequencies above 1GHz, any suitable measuring distance may be used.
- b. The EUT was placed on the top of a rotating table 0.8 meters above the ground at a 3 meter open area test site. The table was rotated 360 degrees to determine the position of the highest radiation.
- c. The height of the equipment or of the substitution antenna shall be 0.8 m; the height of the test antenna shall vary between 1 m to 4 m. Both horizontal and vertical polarizations of the antenna are set to make the measurement.
- d. The initial step in collecting conducted emission data is a spectrum analyzer peak detector mode pre-scanning the measurement frequency range. Significant peaks are then marked and then Quasi Peak detector mode re-measured.
- e. If the Peak Mode measured value compliance with and lower than Quasi Peak Mode Limit, the EUT shall be deemed to meet QP Limits and then no additional QP Mode measurement performed.
- f. For the actual test configuration, please refer to the related Item –EUT Test Photos.

Note:

Both horizontal and vertical antenna polarities were tested and performed pretest to three orthogonal axis. The worst case emissions were reported

### 3.2.3 DEVIATION FROM TEST STANDARD

No deviation

### 3.2.4 TEST SETUP

(A) Radiated Emission Test-Up Frequency Below 30MHz

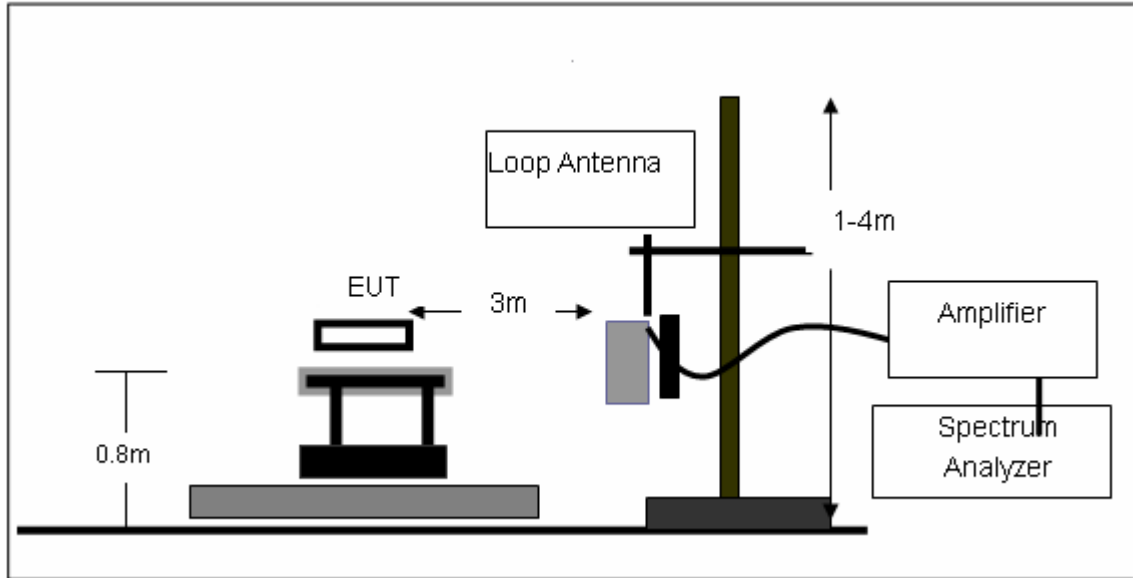

(B) Radiated Emission Test-Up Frequency 30MHz~1GHz

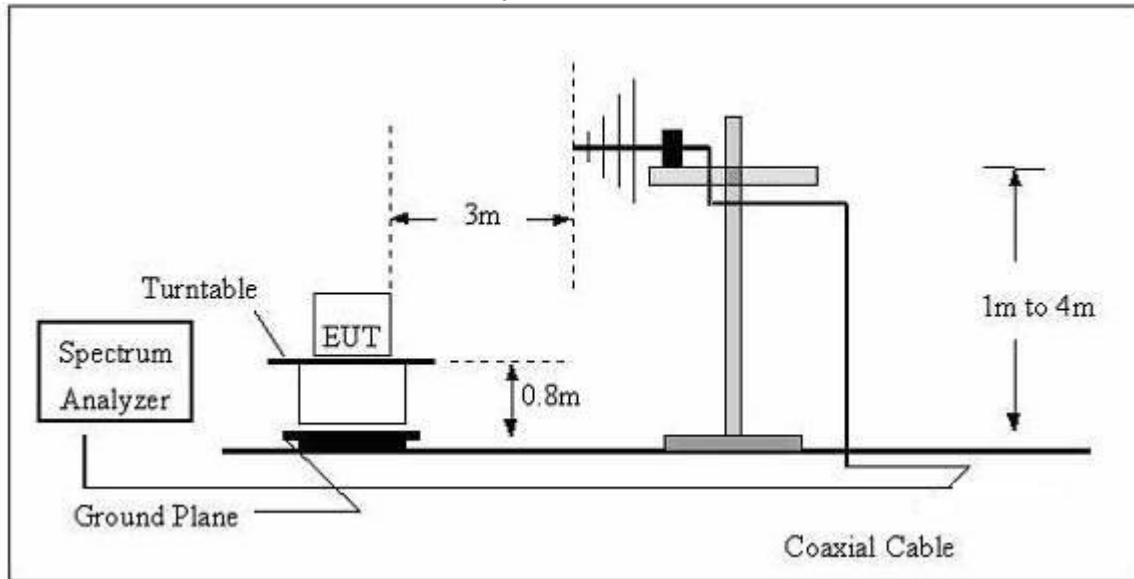

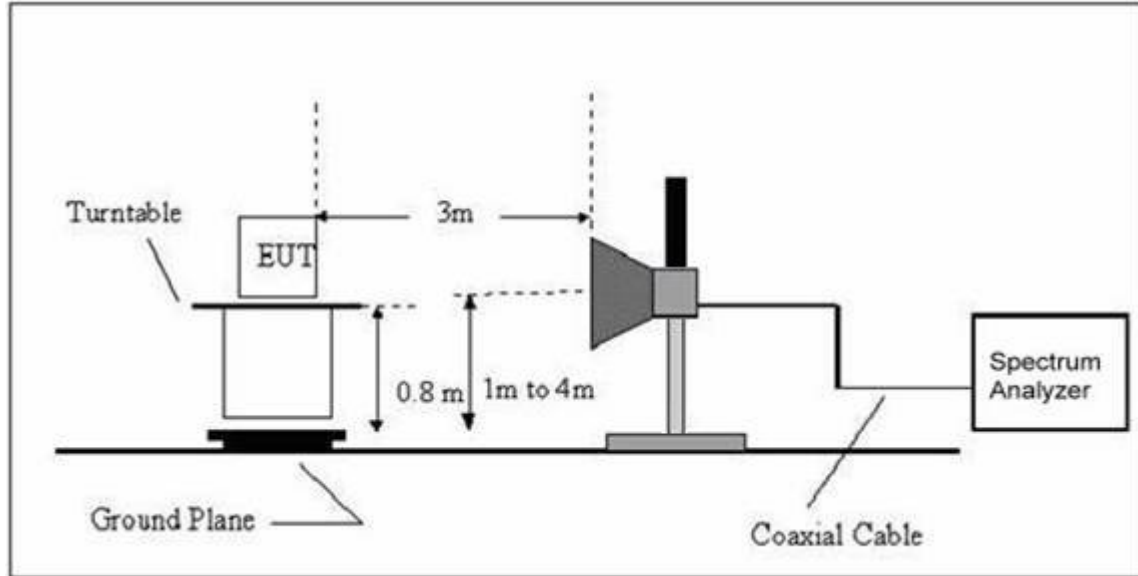
**(C) Radiated Emission Test-Up Frequency Above 1GHz****3.2.5 EUT OPERATING CONDITIONS**

The EUT tested system was configured as the statements of 2.4 Unless otherwise a special operating condition is specified in the follows during the testing.

**3.2.6 TEST RESULTS (BETWEEN 9KHZ – 30 MHZ)**

EUT:	ScreenBeam Mini2 Wireless Display Receiver	Model Name. :	SBWD60A
Temperature:	20 °C	Relative Humidity:	48%
Pressure:	1010 hPa	Test Voltage :	DC 5V From adapter AC120V/60Hz
Test Mode :	TX	Polarization :	--

Freq.	Reading	Limit	Margin	State
(MHz)	(dBuV/m)	(dBuV/m)	(dB)	P/F
--	--	--	--	N/A
--	--	--	--	N/A

**NOTE:**

The amplitude of spurious emissions which are attenuated by more than 20dB below the permissible value has no need to be reported.

Distance extrapolation factor =  $40 \log(\text{specific distance}/\text{test distance})(\text{dB})$ ;

Limit line = specific limits(dBuv) + distance extrapolation factor.



**3.2.7 TEST RESULTS (BETWEEN 30MHZ – 1GHZ)**

EUT :	ScreenBeam Mini2 Wireless Display Receiver	Model Name :	SBWD60A
Temperature :	20 °C	Relative Humidity :	48%
Pressure :	1010 hPa	Test Voltage :	DC 5V From adapter AC120V/60Hz- Adapter 1
Test Mode :	TX (5.0G)		

Comment	Frequency	Meter Reading	Factor	Emission Level	Limits	Margin	Remark
	(MHz)	(dBµV)	(dB)	(dBµV/m)	(dBµV/m)	(dB)	
Below 1G							
Horizontal	60.9176	18.37	7.63	26.00	40.00	-14.00	QP
Horizontal	188.4123	18.31	10.69	29.00	43.50	-14.50	QP
Horizontal	247.6819	17.23	13.57	30.80	46.00	-15.20	QP
Horizontal	287.9904	22.28	14.02	36.30	46.00	-9.70	QP
Horizontal	399.0300	14.53	18.27	32.80	46.00	-13.20	QP
Horizontal	752.7432	14.13	26.17	40.30	46.00	-5.70	QP
Vertica	50.0566	24.83	10.67	35.50	40.00	-4.50	QP
Vertica	157.5586	20.43	10.47	30.90	43.50	-12.60	QP
Vertica	369.4045	18.06	17.04	35.10	46.00	-10.90	QP
Vertica	455.9057	18.68	19.42	38.10	46.00	-7.90	QP
Vertica	526.3967	16.76	20.84	37.60	46.00	-8.40	QP
Vertica	884.5027	15.02	27.08	42.10	46.00	-3.90	QP

EUT :	ScreenBeam Mini2 Wireless Display Receiver	Model Name :	SBWD60A
Temperature :	20 °C	Relative Humidity :	48%
Pressure :	1010 hPa	Test Voltage :	DC 5V From adapter AC120V/60Hz- Adapter 2
Test Mode :	TX (5.0G)		

Comment	Frequency	Meter Reading	Factor	Emission Level	Limits	Margin	Remark
	(MHz)	(dBµV)	(dB)	(dBµV/m)	(dBµV/m)	(dB)	
Below 1G							
Horizontal	146.3735	20.22	10.78	31.00	43.50	-12.50	QP
Horizontal	194.4533	20.26	10.74	31.00	43.50	-12.50	QP
Horizontal	290.0172	24.36	14.04	38.40	46.00	-7.60	QP
Horizontal	392.0951	22.02	17.98	40.00	46.00	-6.00	QP
Horizontal	441.7425	5.56	19.14	34.70	46.00	-11.30	QP
Horizontal	804.6028	13.50	27.40	40.90	46.00	-5.10	QP
Vertica	48.5016	21.74	11.06	32.80	40.00	-7.20	QP
Vertica	119.0180	17.22	11.88	29.10	43.50	-14.40	QP
Vertica	186.4405	17.42	10.68	28.10	43.50	-15.40	QP
Vertica	313.2760	18.69	14.71	33.40	46.00	-12.60	QP
Vertica	447.9821	15.74	19.26	35.00	46.00	-11.00	QP
Vertica	896.9963	12.37	27.03	39.40	46.00	-6.60	QP

### 3.2.8 TEST RESULTS (ABOVE 1000 MHZ)

EUT :	ScreenBeam Mini2 Wireless Display Receiver	Model Name :	SBWD60A
Temperature :	20 °C	Relative Humidity :	48%
Pressure :	1010 hPa	Test Voltage :	DC 5V From adapter AC120V/60Hz
Test Mode :	TX (5.0G)		

Polar (H/V)	Frequency	Meter Reading	Factor	Emission Level	Limits	Margin	Detector Type
	(MHz)	(dBuV)	(dB)	(dBuV/m)	(dBuV/m)	(dB)	
Low Channel (5180 MHz)-Above 1G							
Vertical	10360.000	38.45	13.09	51.54	74	-22.46	Pk
Vertical	15540.000	35.31	15.16	50.47	74	-23.53	Pk
Horizontal	10360.000	37.22	13.09	50.31	74	-23.69	Pk
Horizontal	15540.000	33.09	15.16	48.25	74	-25.75	Pk
middle Channel (5200 MHz)-Above 1G							
Vertical	10400.000	37.54	13.11	50.65	74	-23.35	Pk
Vertical	15600.000	36.21	15.19	51.4	74	-22.6	Pk
Horizontal	10400.000	31.13	13.11	44.24	74	-29.76	Pk
Horizontal	15600.000	36.45	15.19	51.64	74	-22.36	Pk
High Channel (5240 MHz)-Above 1G							
Vertical	10480.000	39.21	13.19	52.4	74	-21.60	Pk
Vertical	15720.000	36.92	15.25	52.17	74	-21.83	Pk
Horizontal	10480.000	33.22	13.19	46.41	74	-27.59	Pk
Horizontal	15720.000	36.13	15.34	51.47	74	-22.53	Pk

Note: "802.11a(5G)" mode is the worst mode. When PK value is lower than the Average value limit, average didn't record.

Conducted Spurious Emissions at Antenna Port:

5GHz: Antenna A

802.11a Low Channel

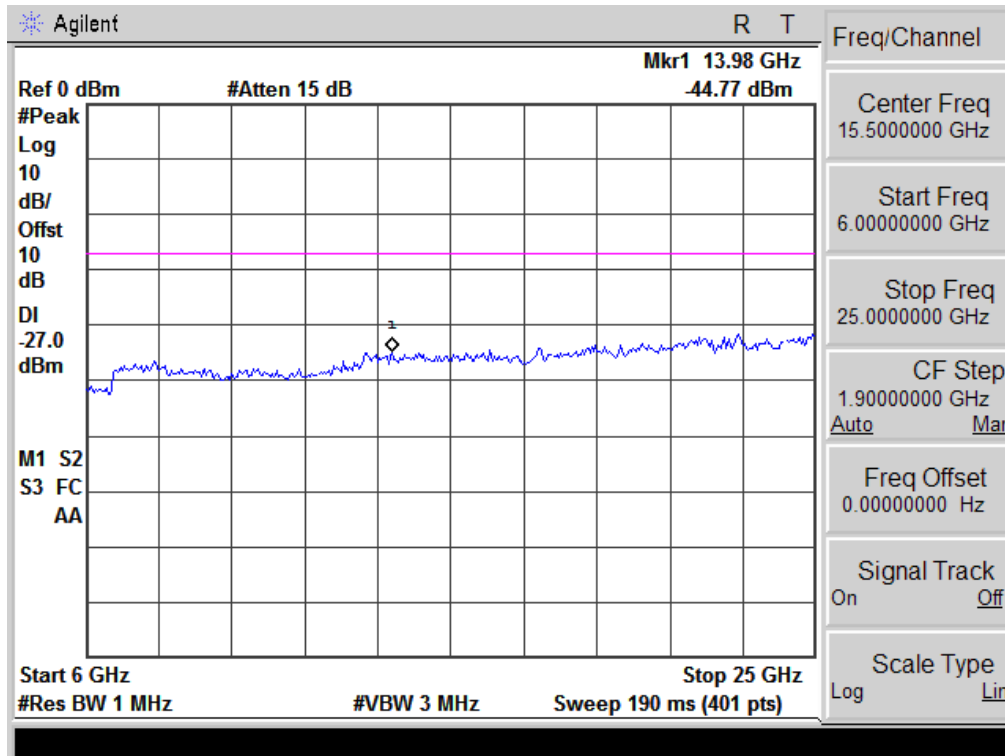
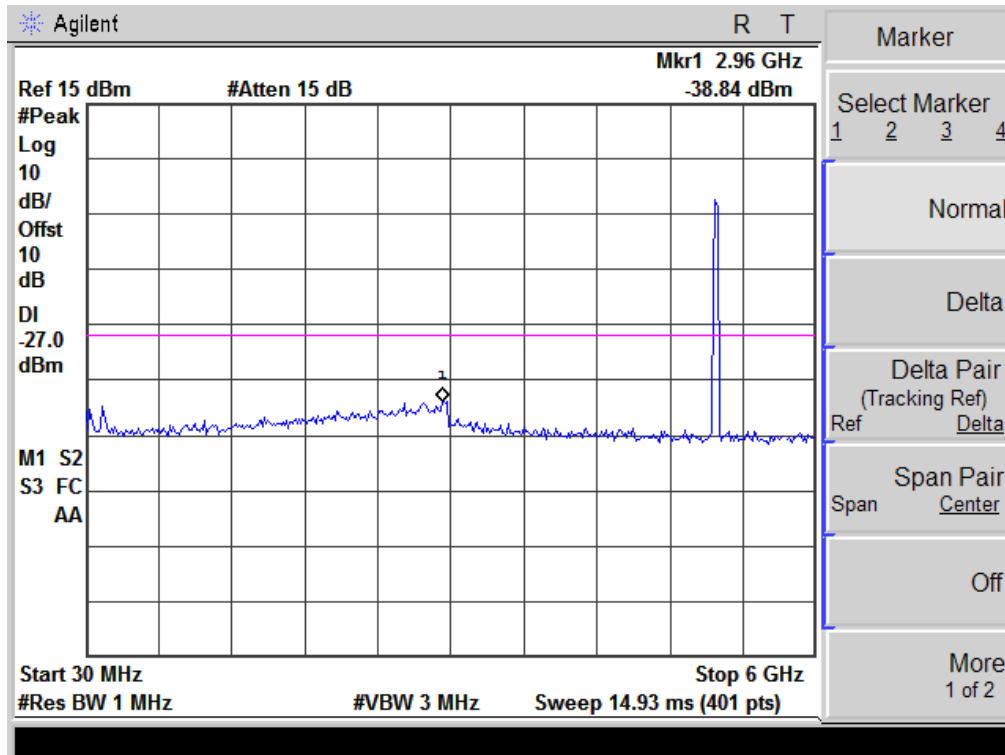

Note: No emission detected above 25GHz

802.11a Middle Channel

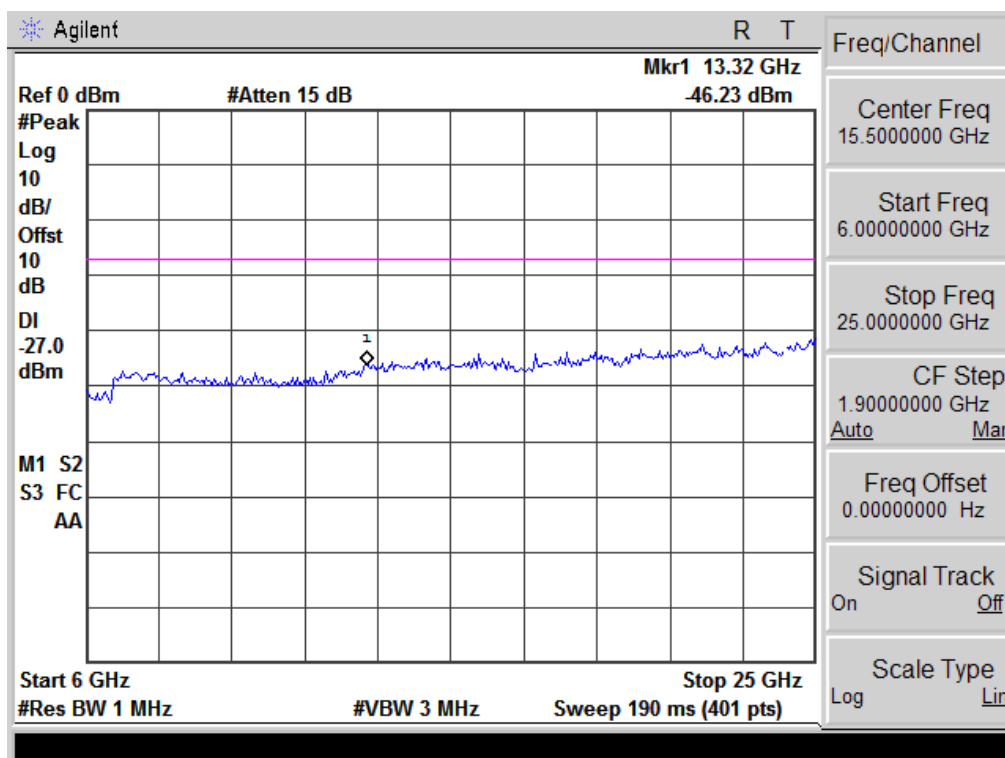
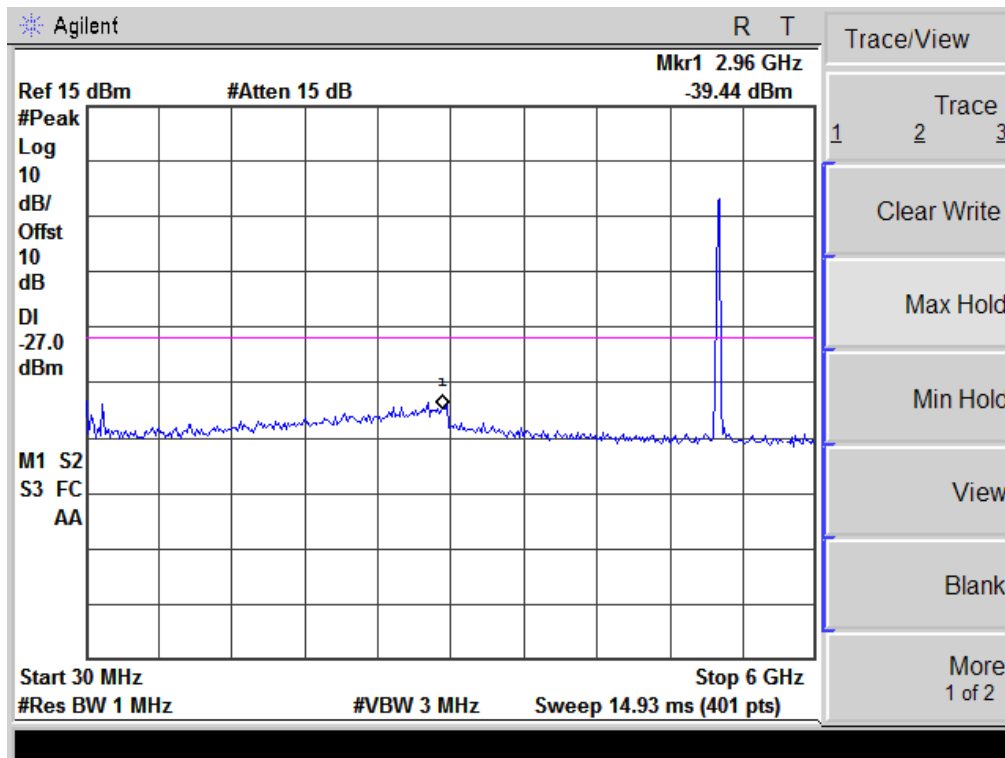

Note: No emission detected above 25GHz

### 802.11a High Channel

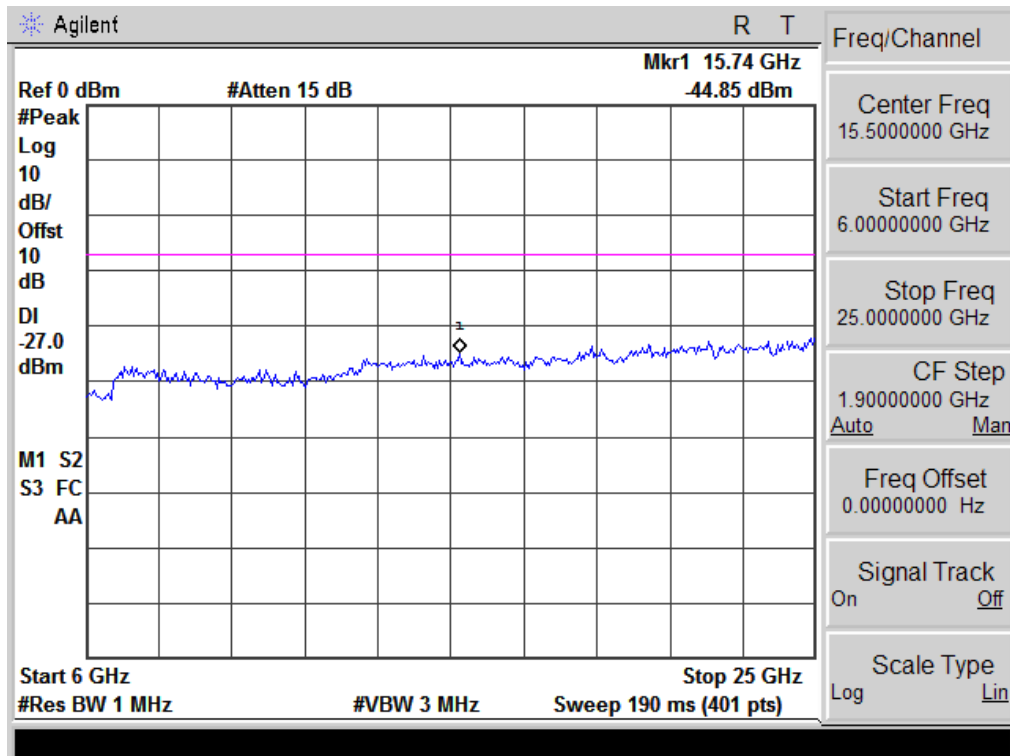
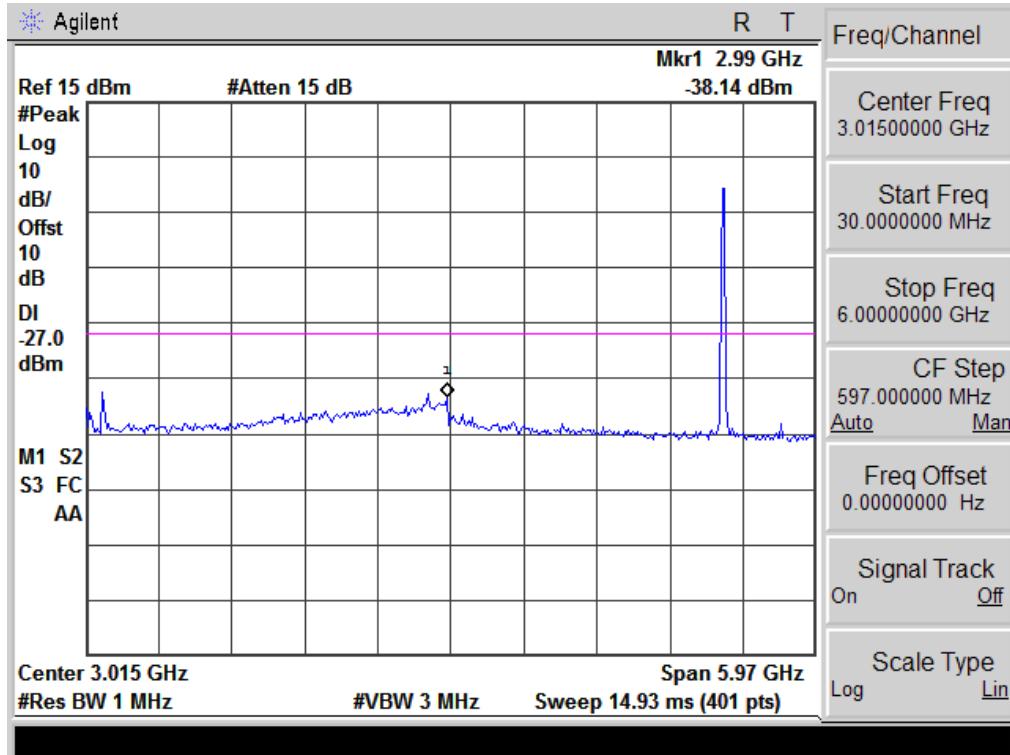

Note: No emission detected above 25GHz

802.11n(20) Low Channel

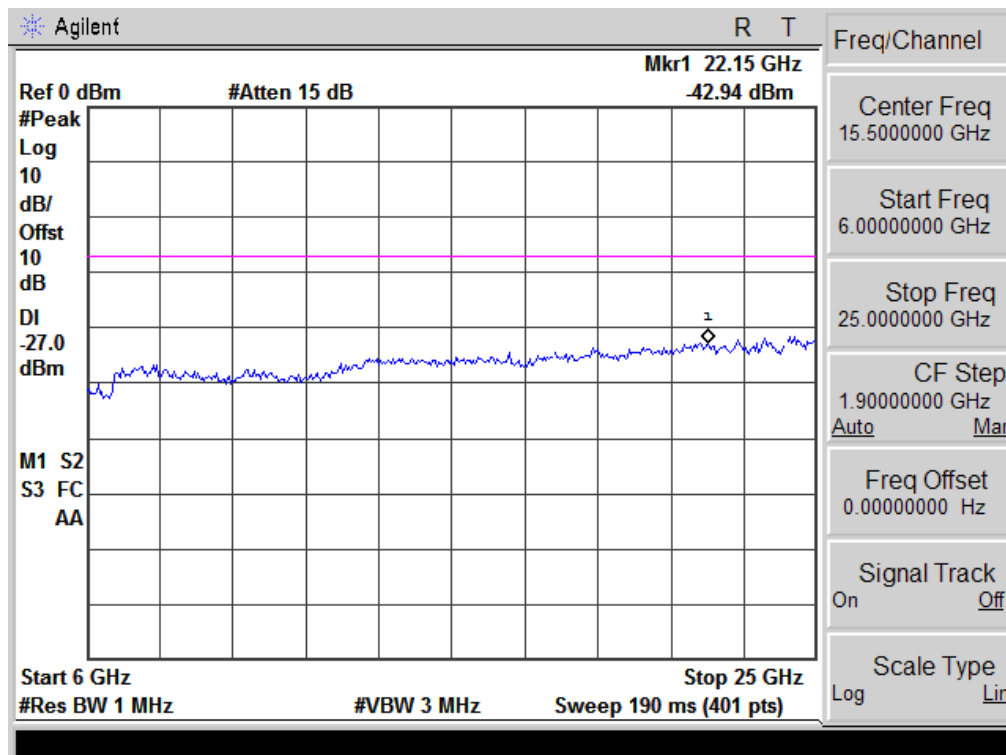
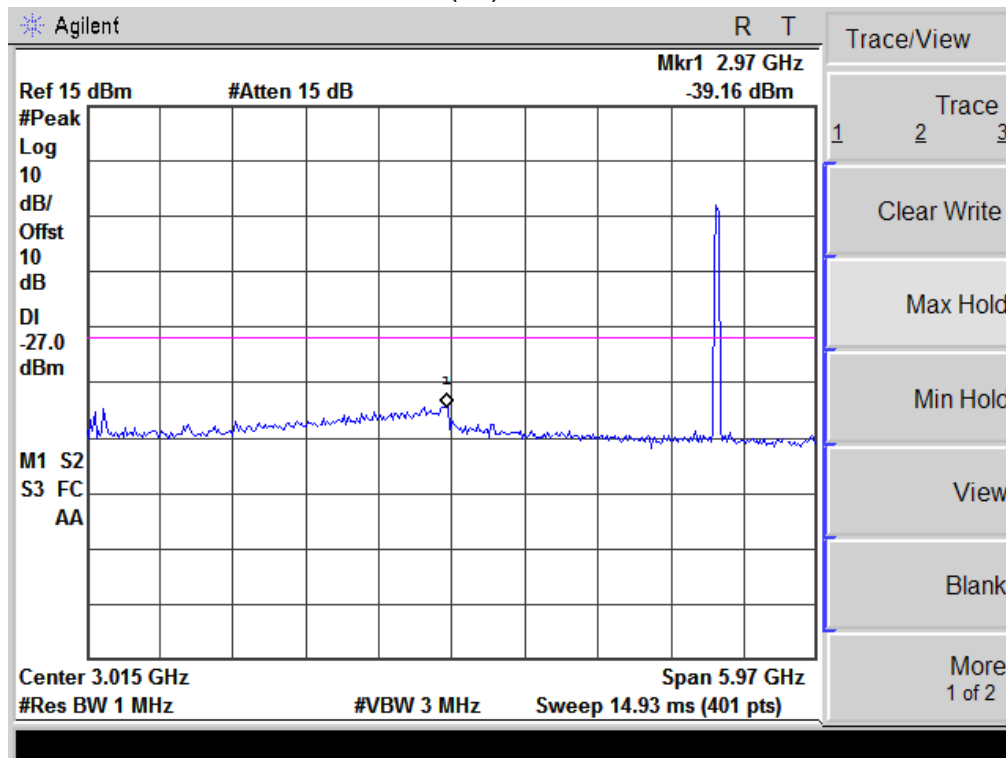

Note: No emission detected above 25GHz

802.11n(20) Middle Channel

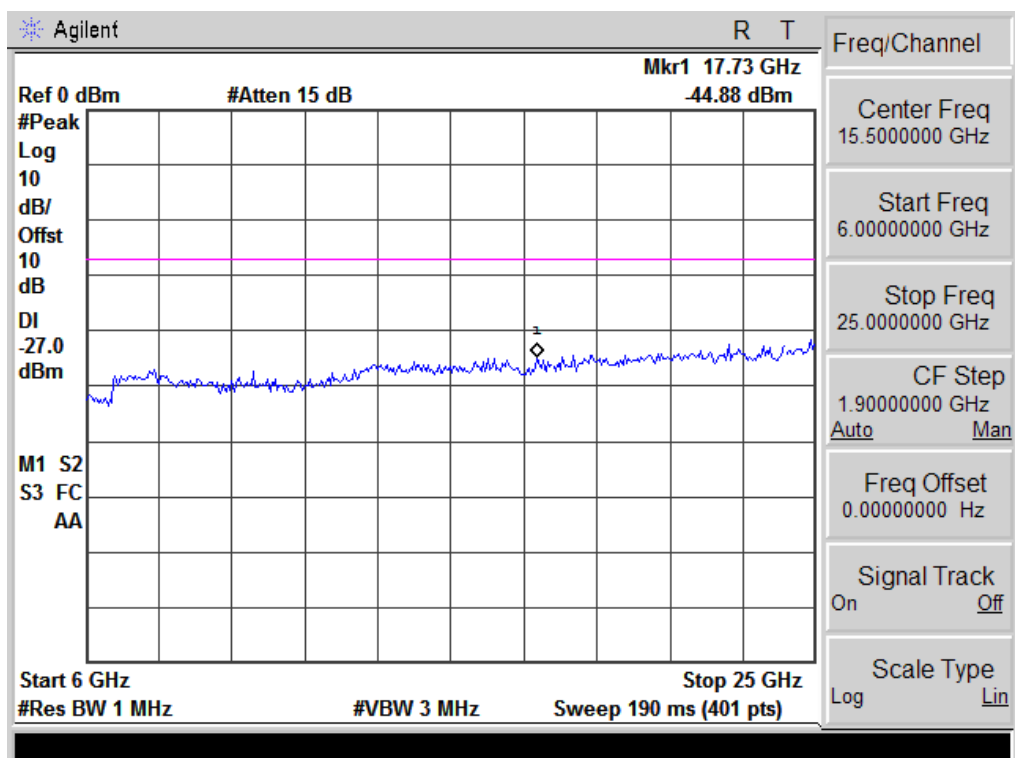
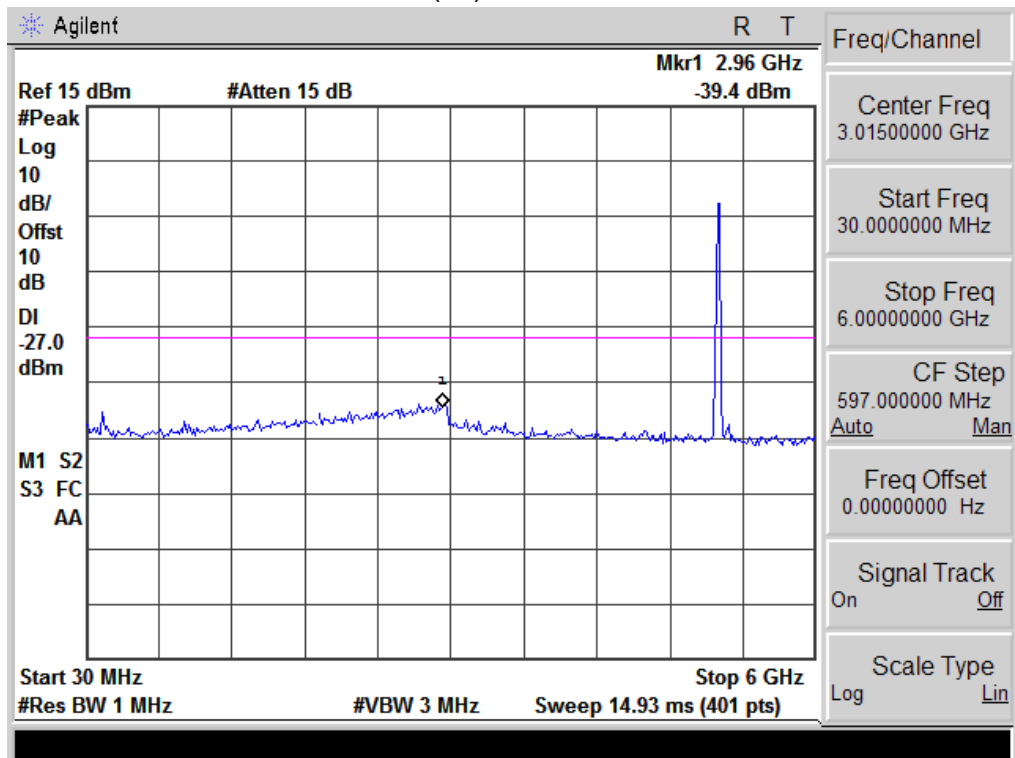

Note: No emission detected above 25GHz



802.11n(20) High Channel

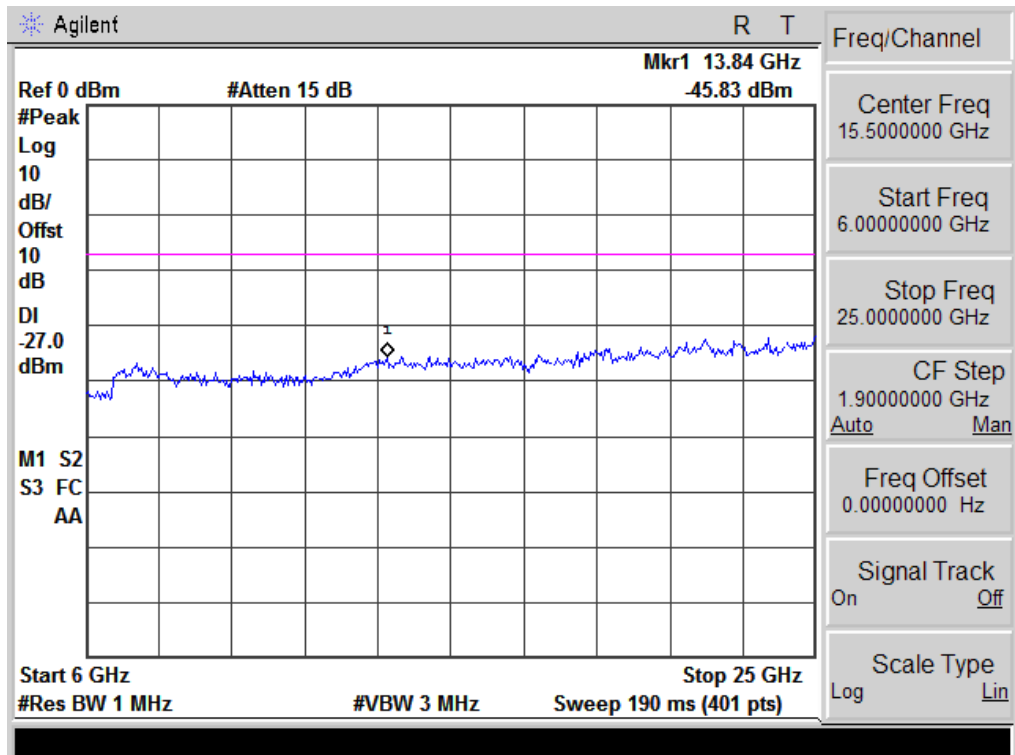
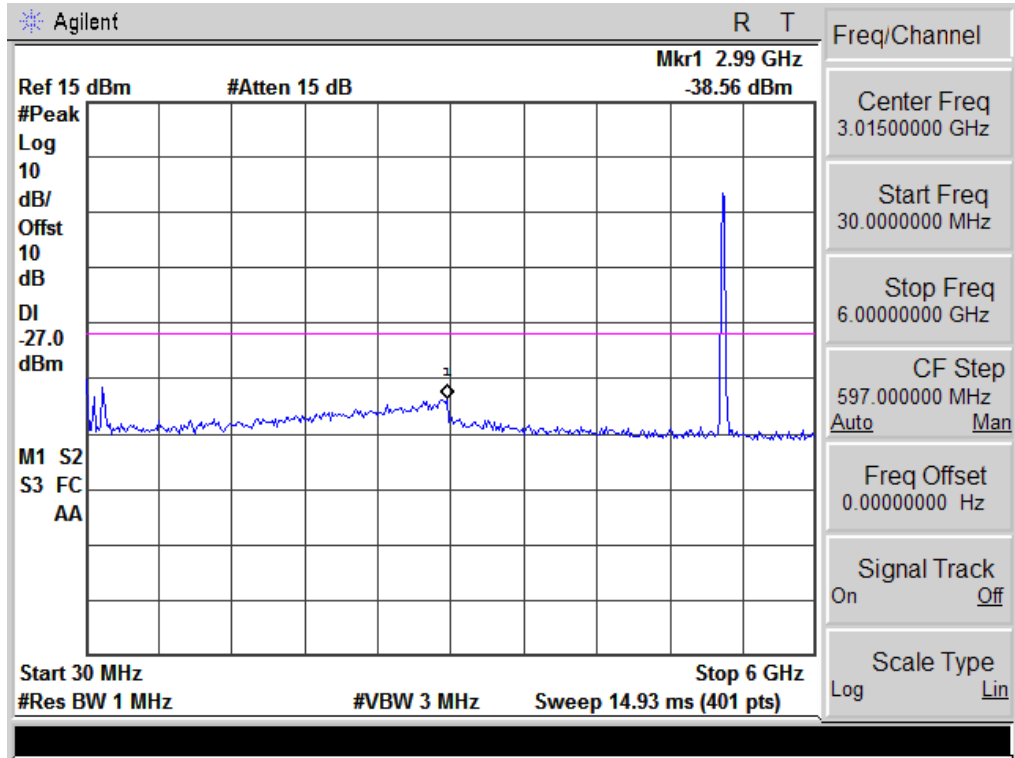

Note: No emission detected above 25GHz

802.11n 40 Low Channel

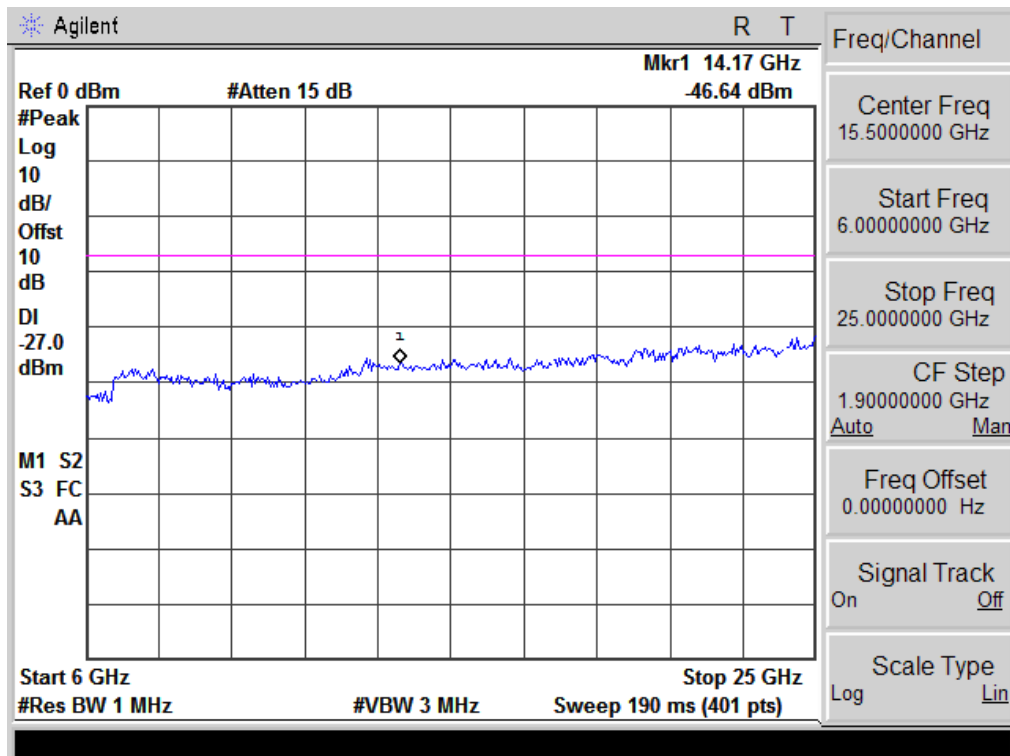
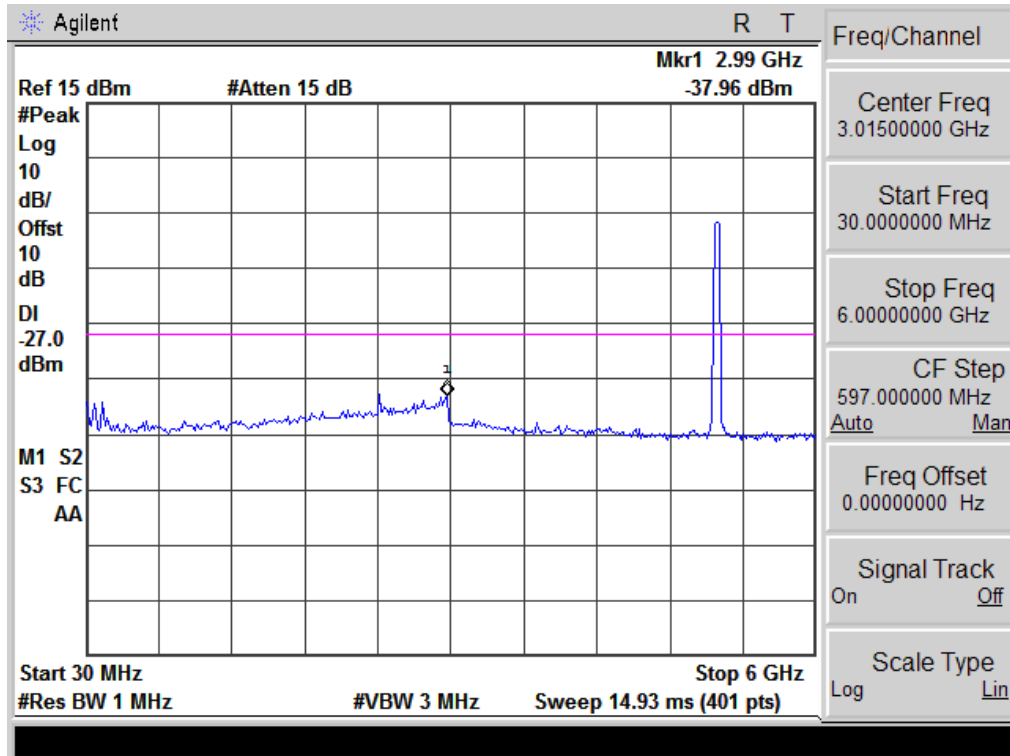

Note: No emission detected above 25GHz

802.11n 40 High Channel

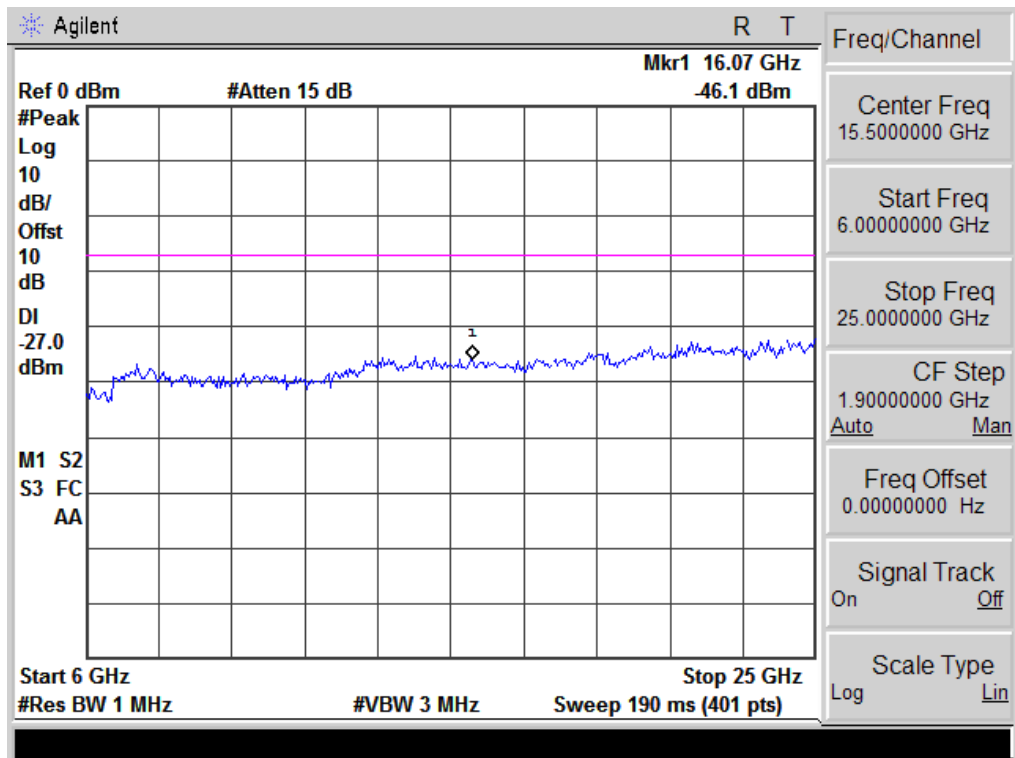
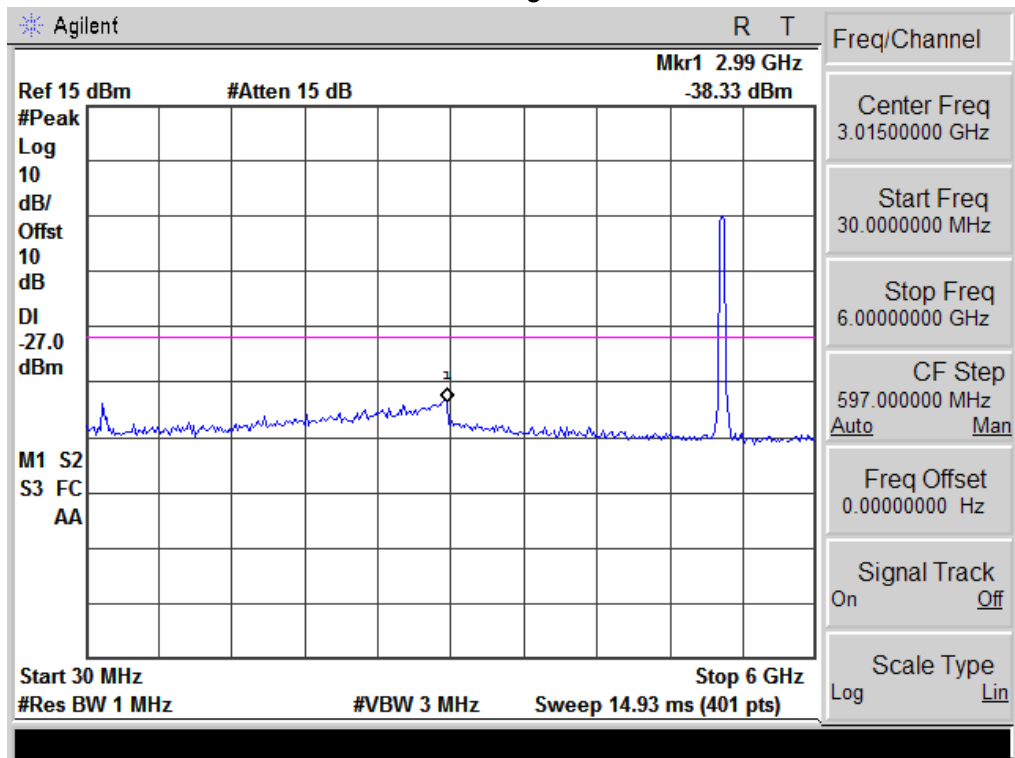

Note: No emission detected above 25GHz

5GHz: Antenna B

802.11a Low Channel

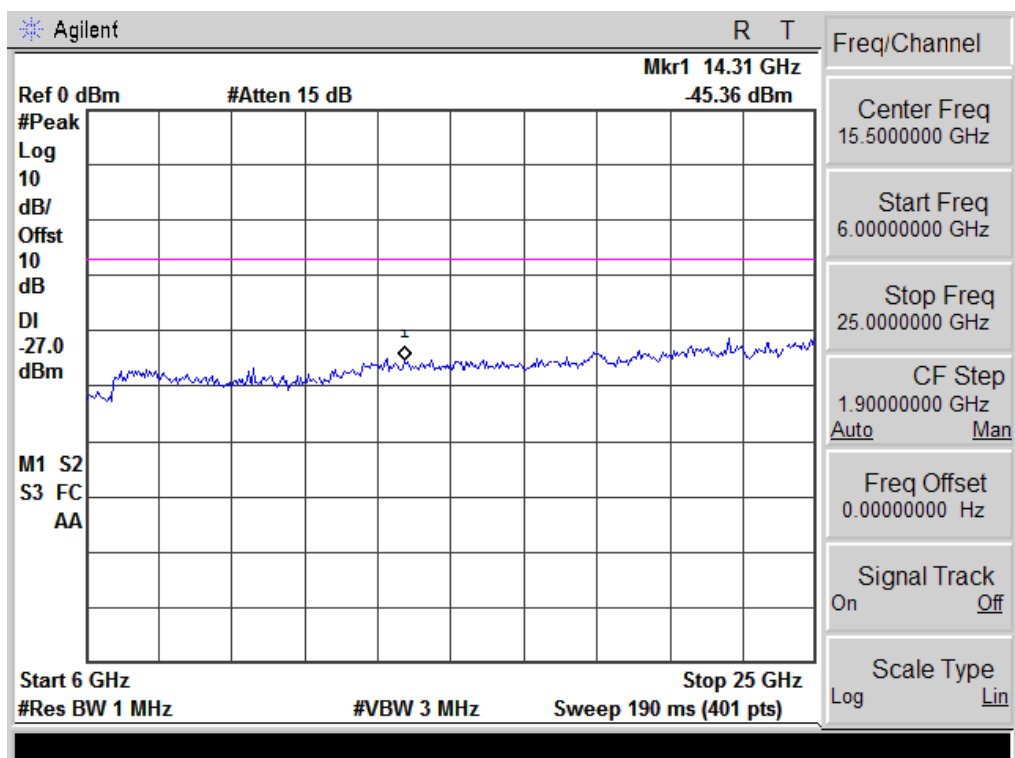
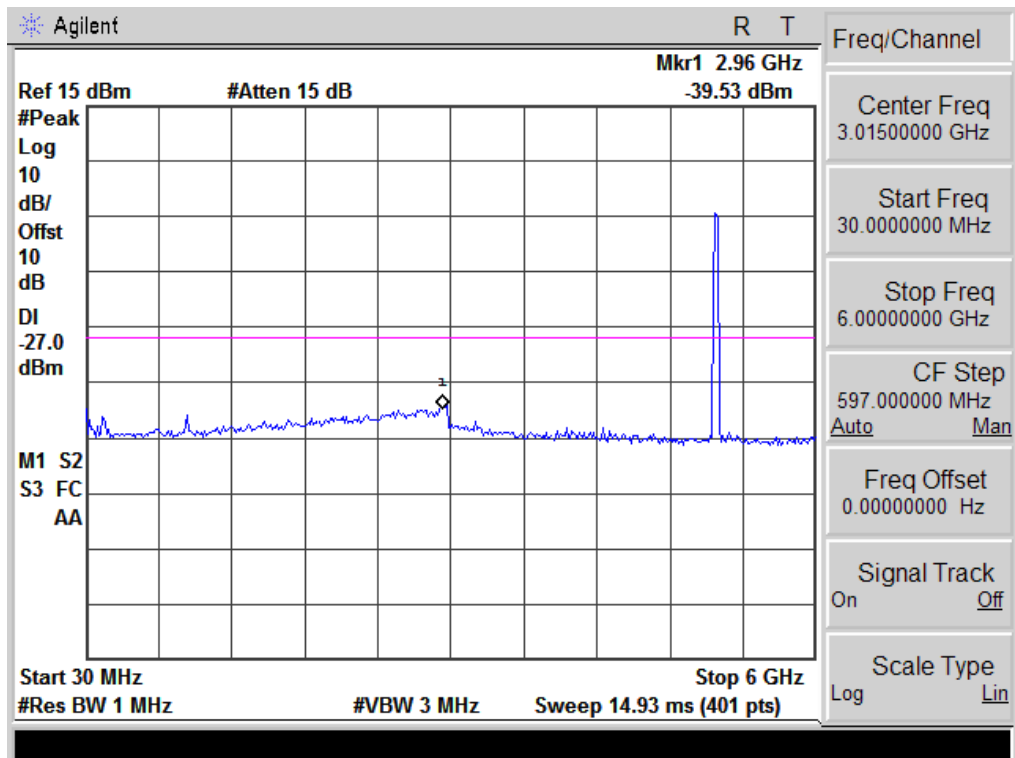

Note: No emission detected above 25GHz

802.11a Middle Channel

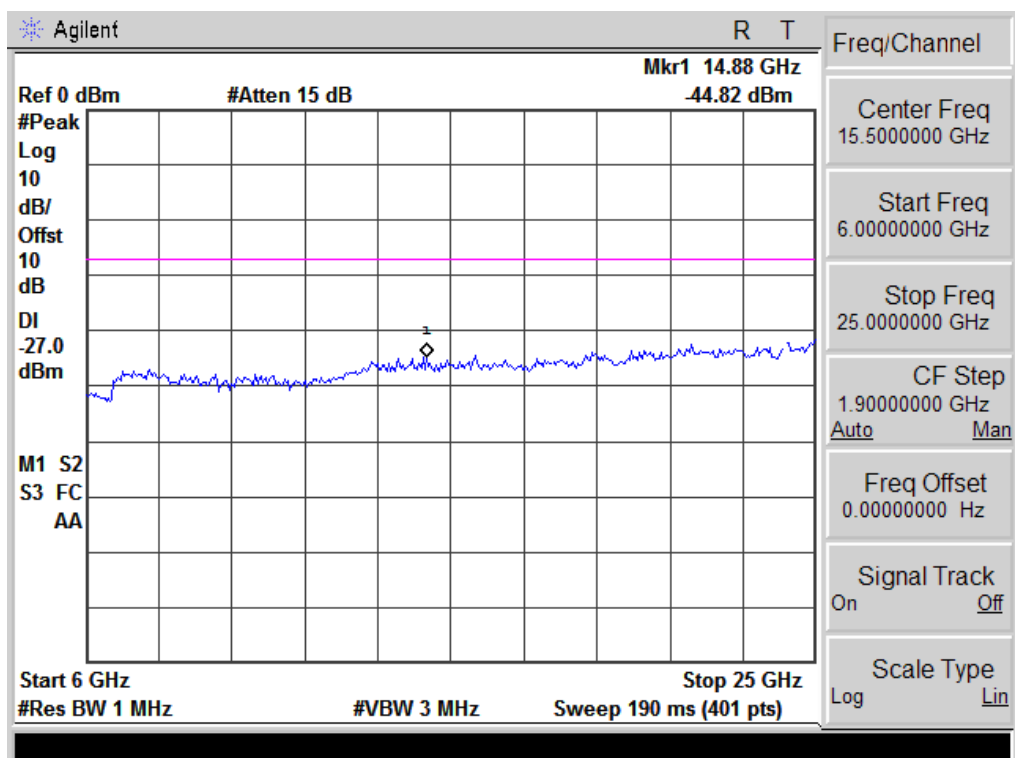
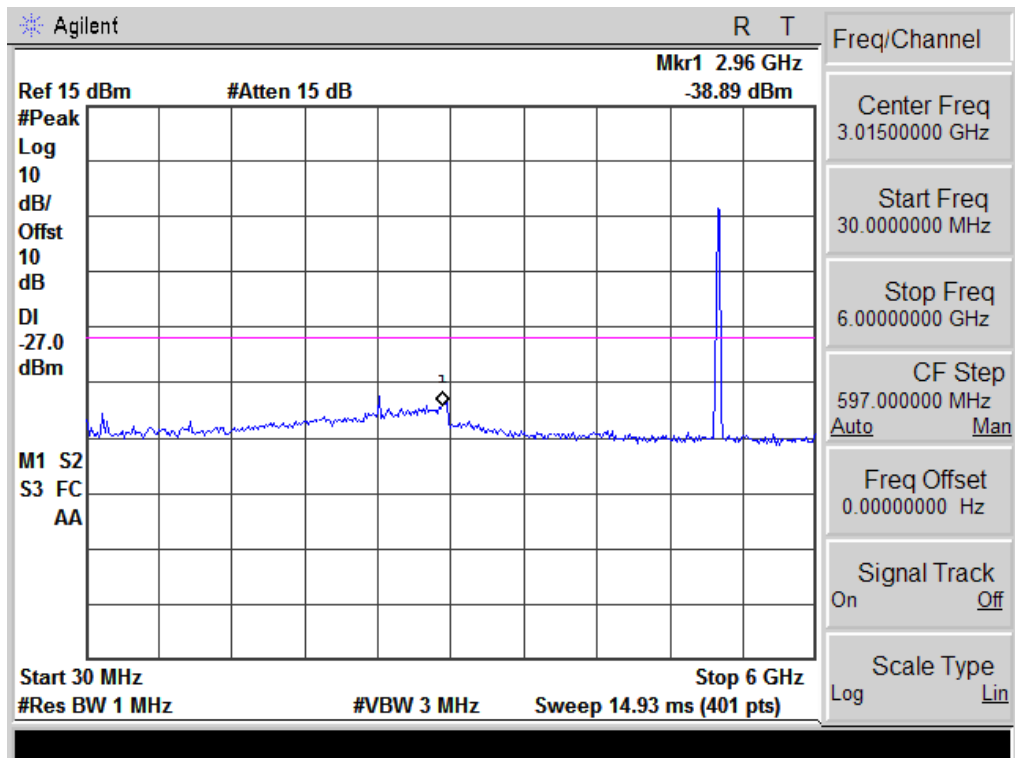

Note: No emission detected above 25GHz

### 802.11a High Channel

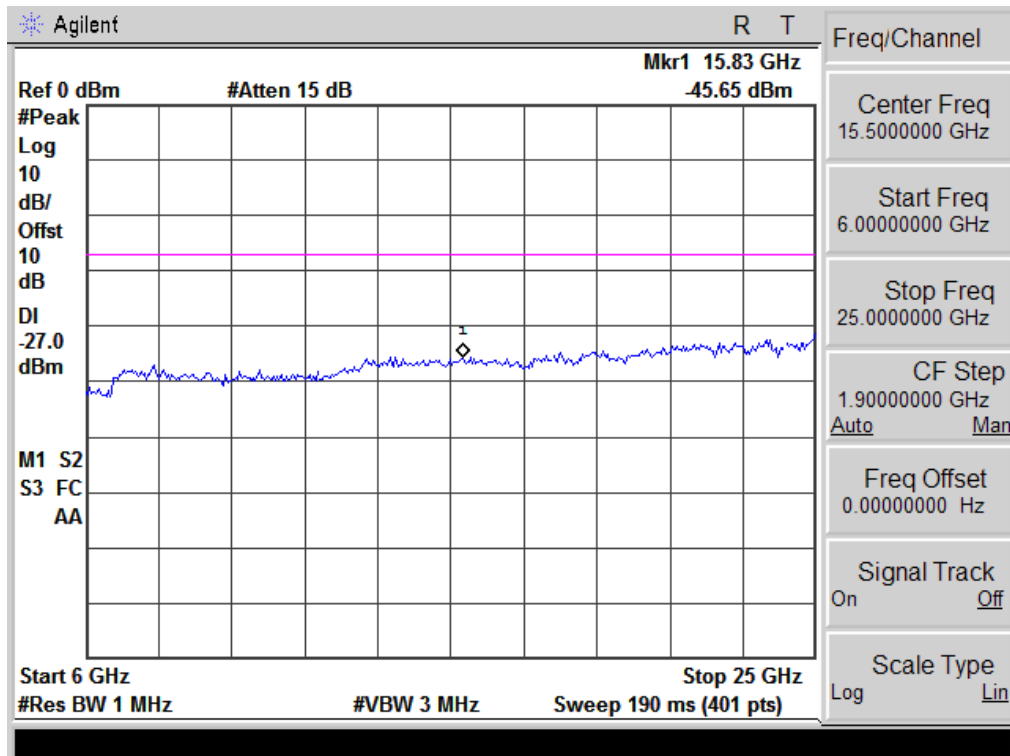
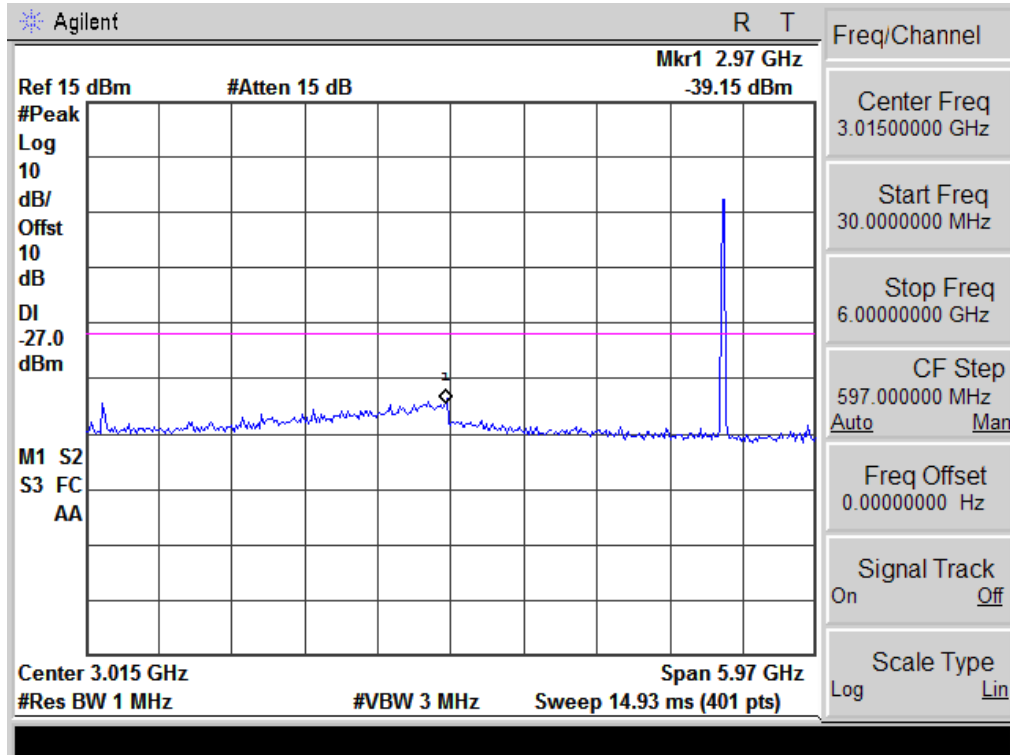

Note: No emission detected above 25GHz

802.11n(20) Low Channel

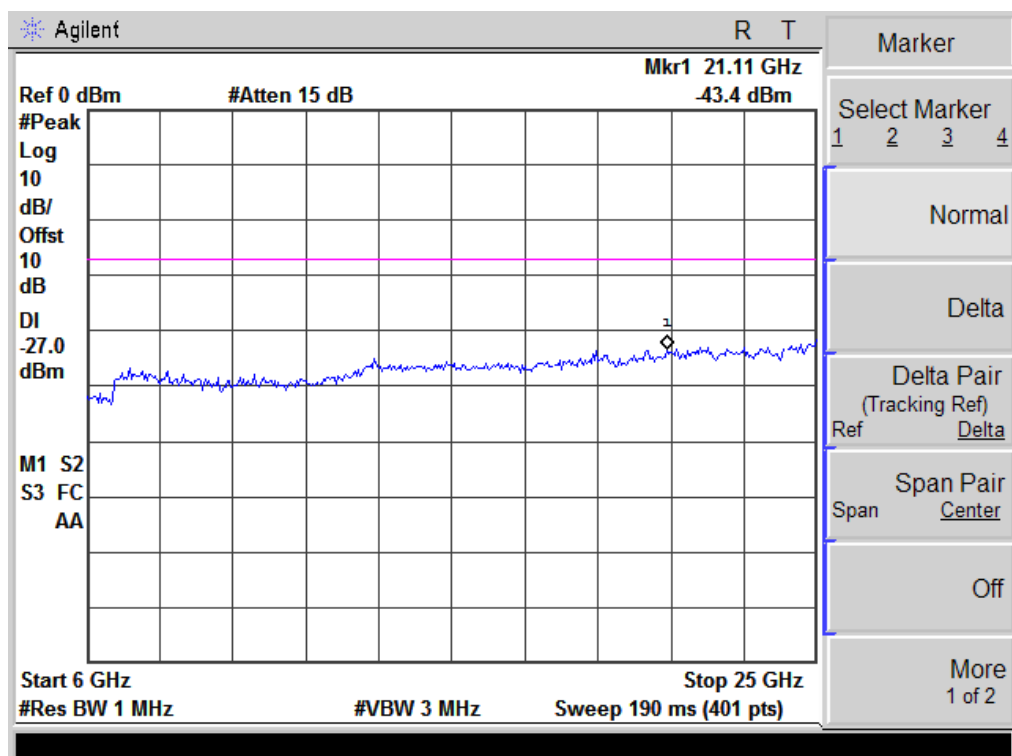
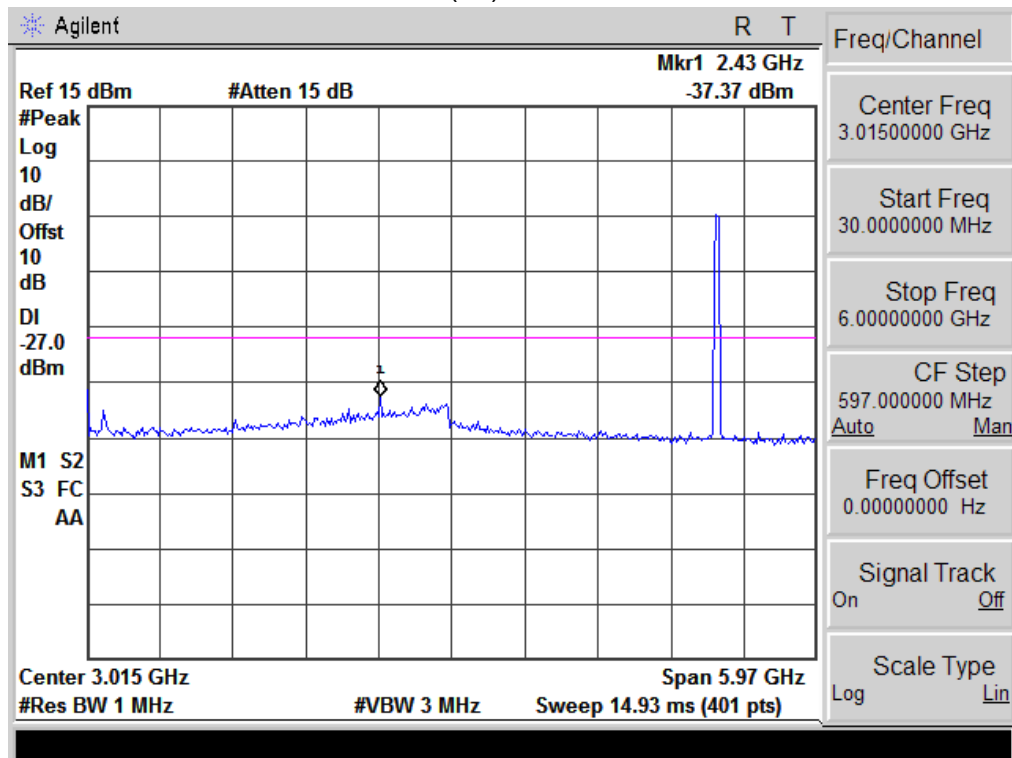

Note: No emission detected above 25GHz

802.11n(20) Middle Channel

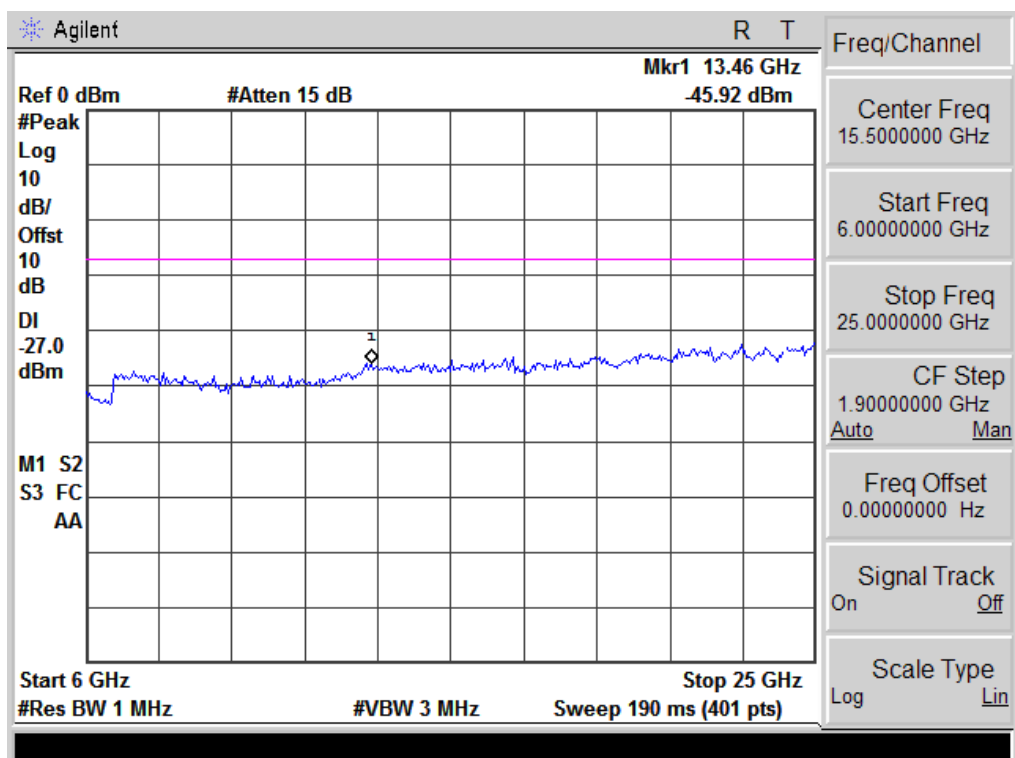
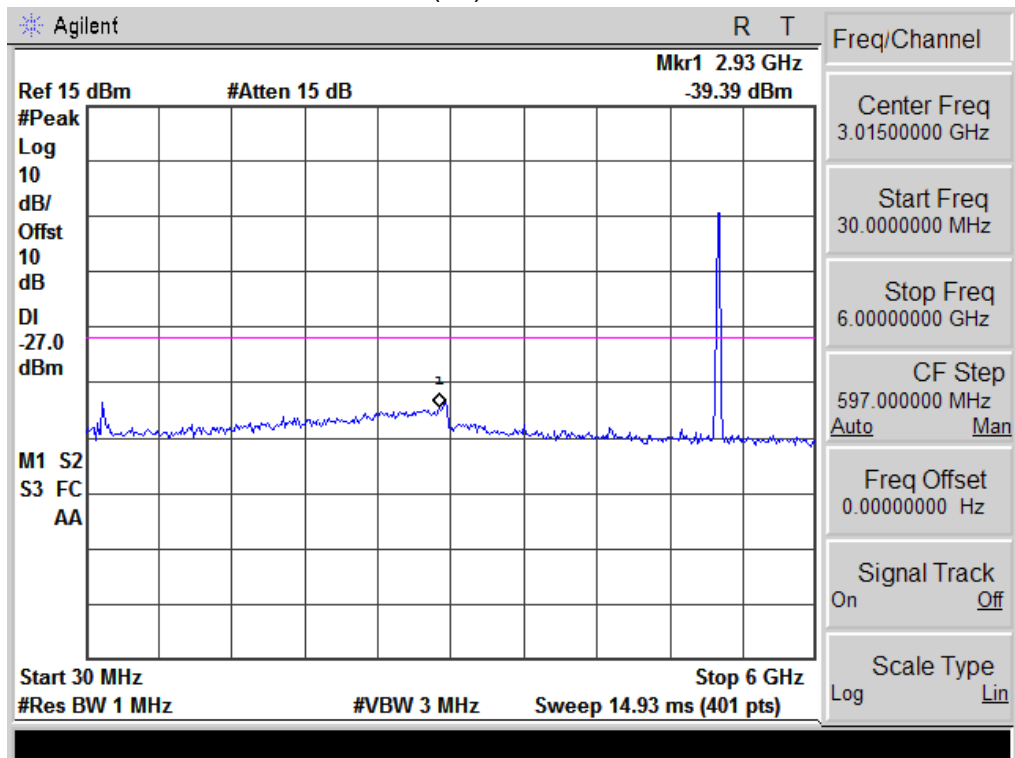

Note: No emission detected above 25GHz



802.11n(20) High Channel

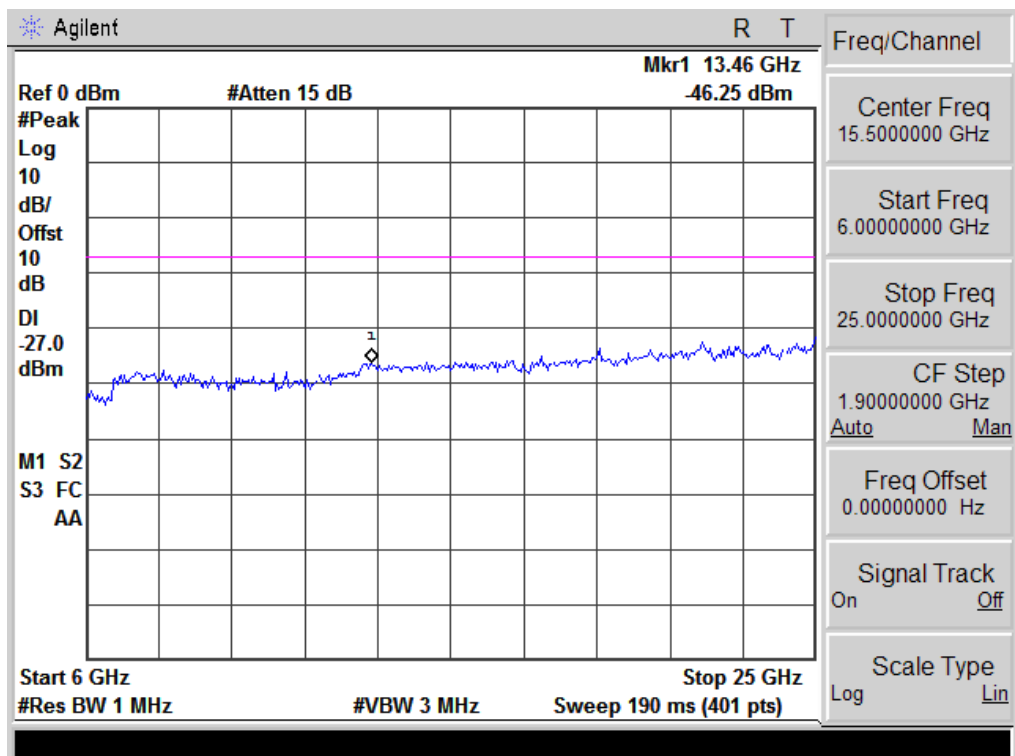
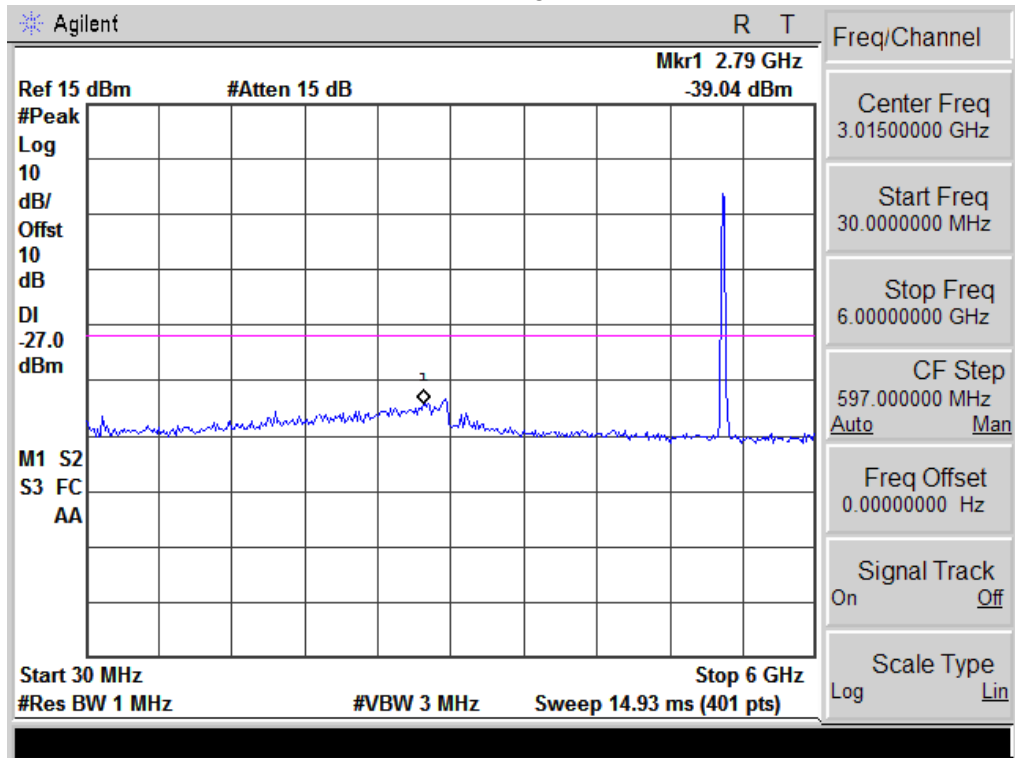

Note: No emission detected above 25GHz

802.11n 40 Low Channel

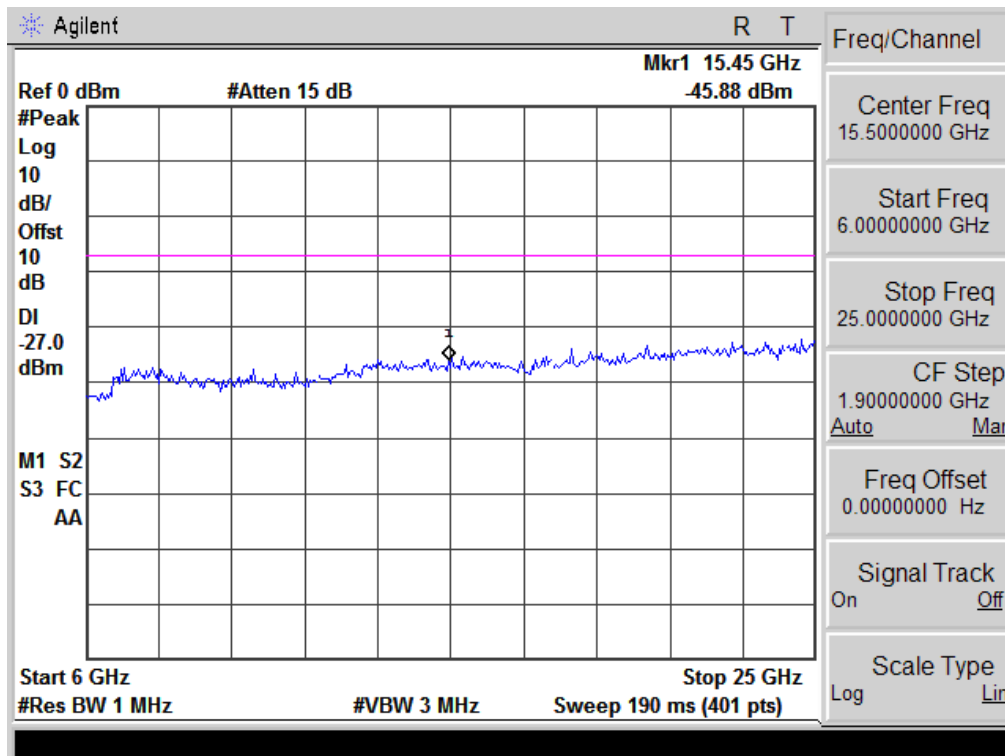
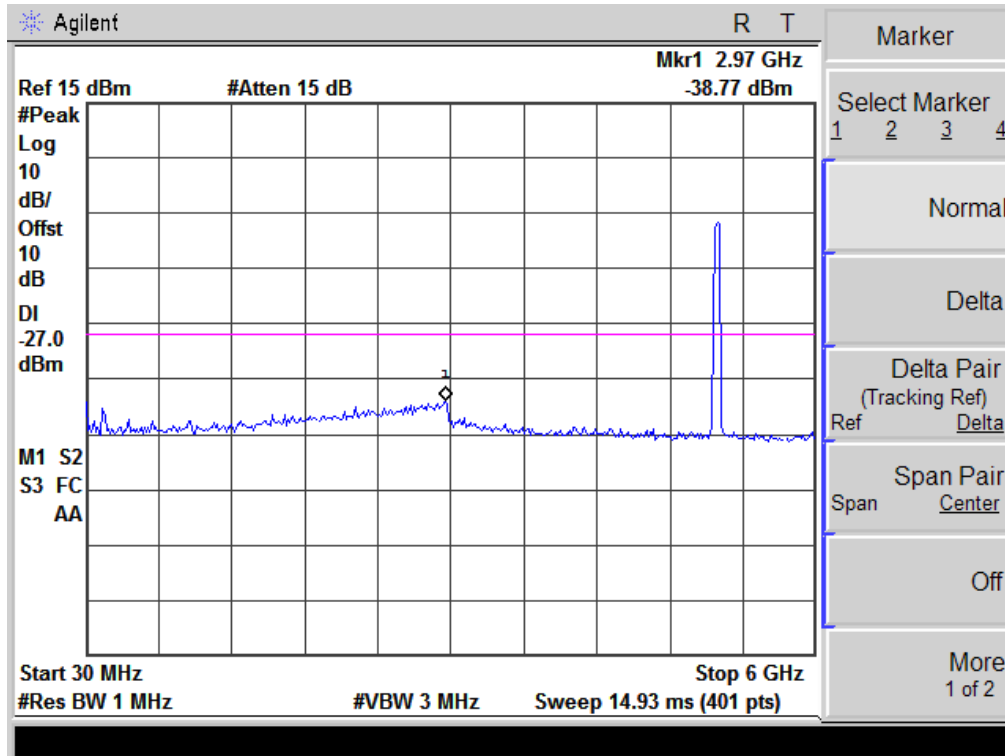

Note: No emission detected above 25GHz

802.11n 40 High Channel

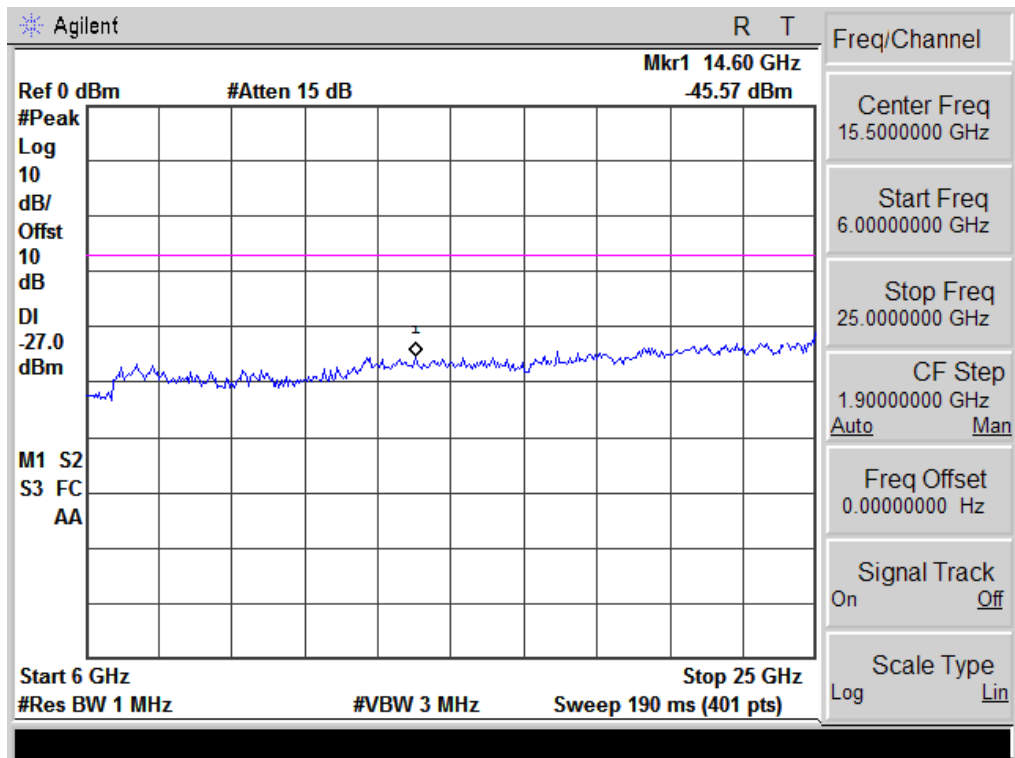
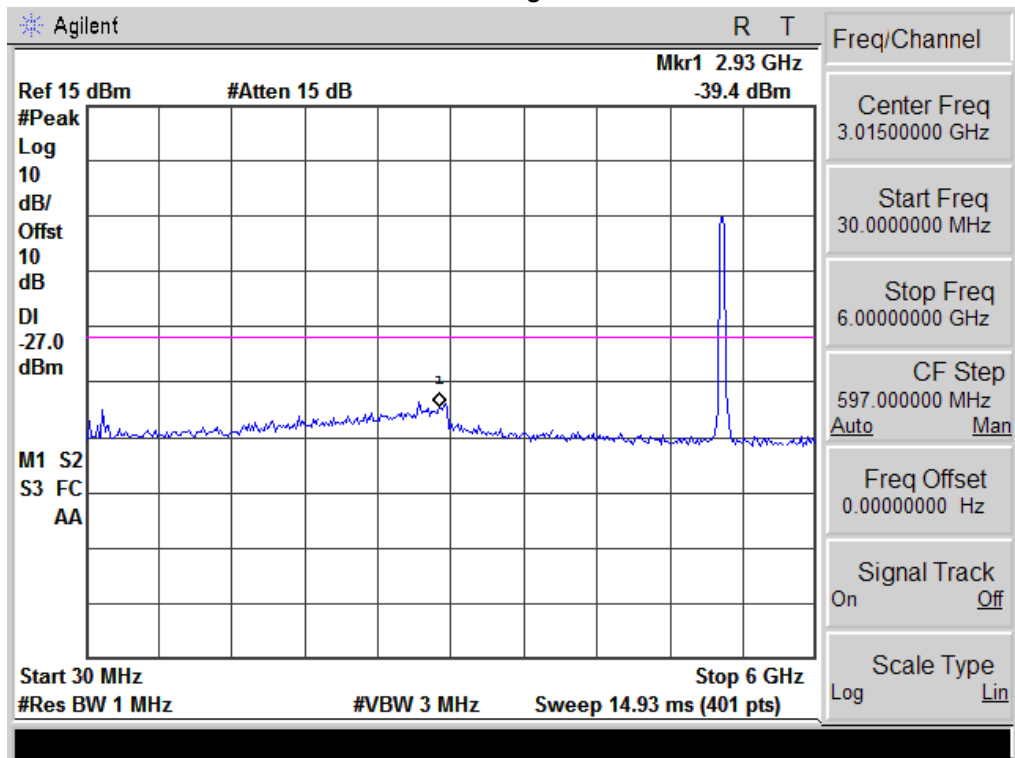

Note: No emission detected above 25GHz

## 4. POWER SPECTRAL DENSITY TEST

### 4.1 APPLIED PROCEDURES / LIMIT

#### According to FCC §15.407(a)(1)

For the band 5.15–5.25 GHz, the maximum conducted output power over the frequency band of operation shall not exceed the lesser of 50 mW or  $4 \text{ dBm} + 10 \log B$ , where B is the 26-dB emission bandwidth in MHz. In addition, the peak power spectral density shall not exceed 4 dBm in any 1-MHz band. If transmitting antennas of directional gain greater than 6 dBi are used, both the maximum conducted output power and the peak power spectral density shall be reduced by the amount in dB that the directional gain of the antenna exceeds 6 dBi.

#### According to IC RSS-210 §A9.2:

5150-5250MHz the maximum e.i.r.p. shall not exceed 200 mW or  $10 + 10 \log_{10} B$ , dBm, whichever power is less. B is the 99% emission bandwidth in MHz. The e.i.r.p. spectral density shall not exceed 10 dBm in any 1.0 MHz band.

#### 4.1.1 TEST PROCEDURE

- (i) Set span to encompass the entire emission bandwidth (EBW) of the signal.
- (ii) Set RBW = 1 MHz.
- (iii) Set VBW  $\geq$  3 MHz.
- (iv) Number of points in sweep  $\geq$  2 Span / RBW. (This ensures that bin-to-bin spacing is  $\leq$  RBW/2, so that narrowband signals are not lost between frequency bins.)
- (v) Sweep time = auto.
- (vi) Detector = RMS (i.e., power averaging), if available. Otherwise, use sample detector mode.
- (vii) If transmit duty cycle < 98 percent, use a video trigger with the trigger level set to enable triggering only on full power pulses. Transmitter must operate at maximum power control level for the entire duration of every sweep. If the EUT transmits continuously (i.e., with no off intervals) or at duty cycle  $\geq$  98 percent, and if each transmission is entirely at the maximum power control level, then the trigger shall be set to “free run”.
- (viii) Trace average at least 100 traces in power averaging (i.e., RMS) mode.
- (ix) Compute power by integrating the spectrum across the 26 dB EBW of the signal using the spectrum analyzer’s band power measurement function with band limits set equal to the EBW band edges. If the spectrum analyzer does not have a band power function, sum the spectrum levels (in power units) at 1 MHz intervals extending across the 26 dB EBW of the spectrum.

#### 4.1.2 DEVIATION FROM STANDARD

No deviation.

#### 4.1.3 TEST SETUP

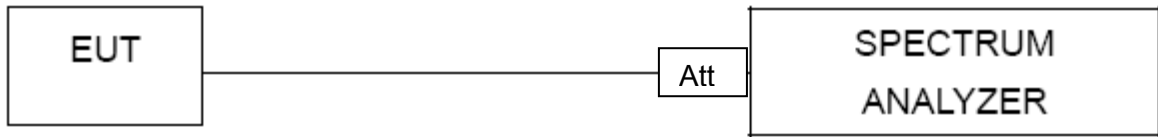

#### 4.1.4 EUT OPERATION CONDITIONS

The EUT tested system was configured as the statements of 2.1 Unless otherwise a special operating condition is specified in the follows during the testing.

### 4.1.5 TEST RESULTS

EUT :	ScreenBeam Mini2 Wireless Display Receiver	Model Name :	SBWD60A
Temperature :	25 °C	Relative Humidity :	56%
Pressure :	1015 hPa	Test Voltage :	DC 5V From adapter AC120V/60Hz
Test Mode :	TX a Mode /CH36, CH40, CH48		

Frequency	Power Density A (dBm)	Power Density B (dBm)	total power density (dBm)	Limit (dBm)	Result
5180 MHz	-3.915	-5.193	-1.497	0.94	PASS
5200 MHz	-3.560	-5.130	-1.470	0.94	PASS
5240 MHz	-1.809	-3.305	0.517	0.94	PASS

The antenna gain of 5 GHz is 9.06 dBi; therefore, the power spectral density limit is reduced by 3.06 dB.

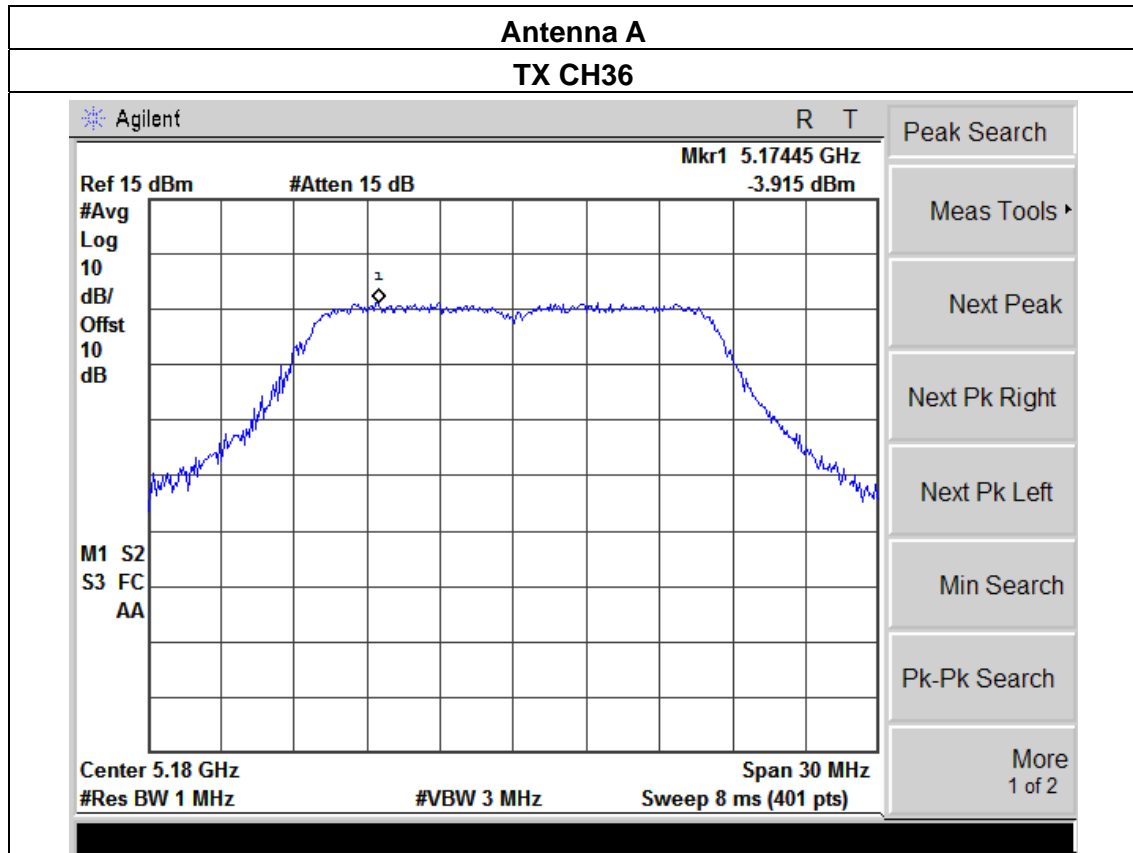

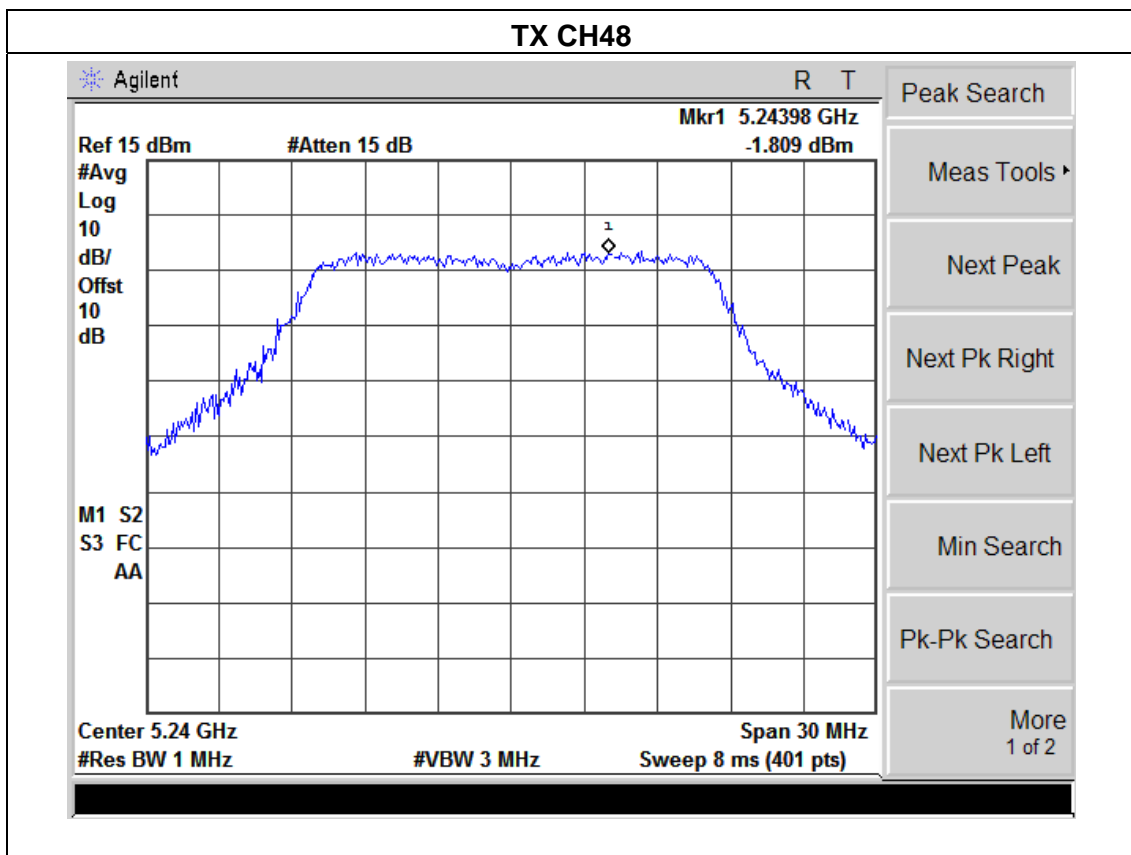
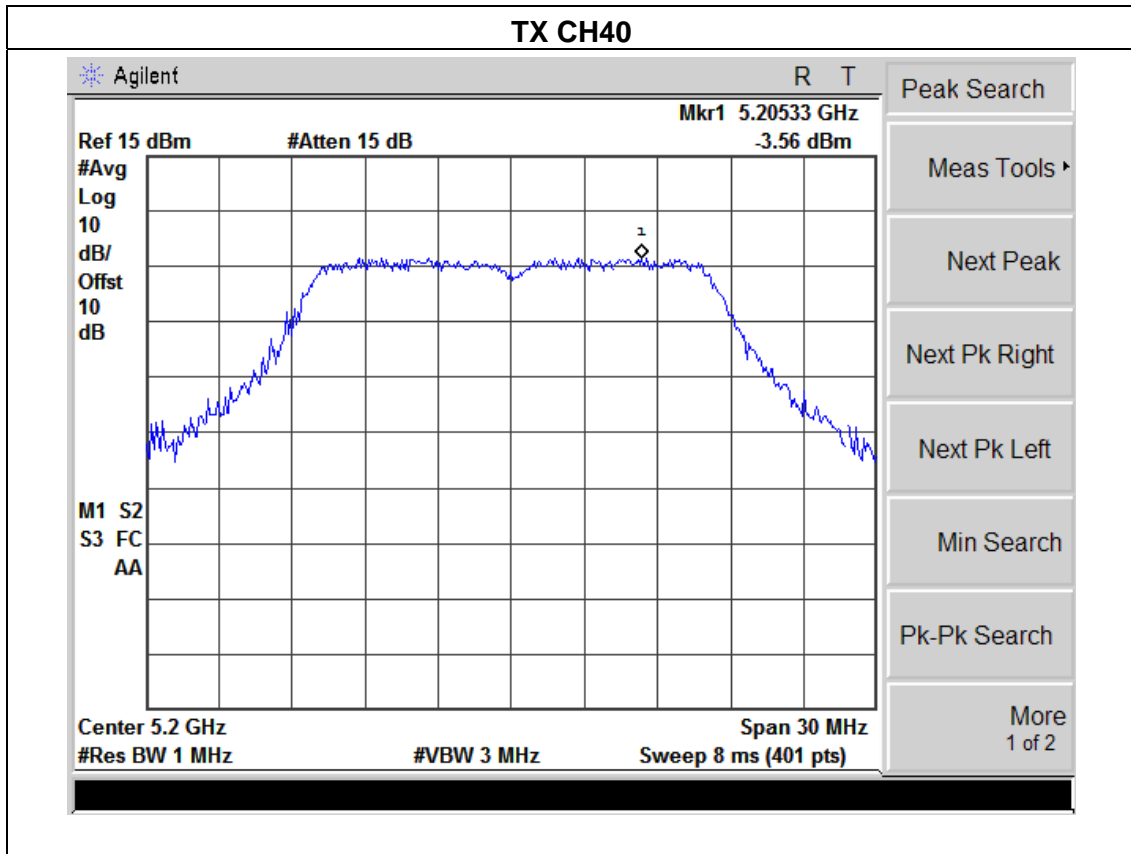

### Antenna B TX CH36

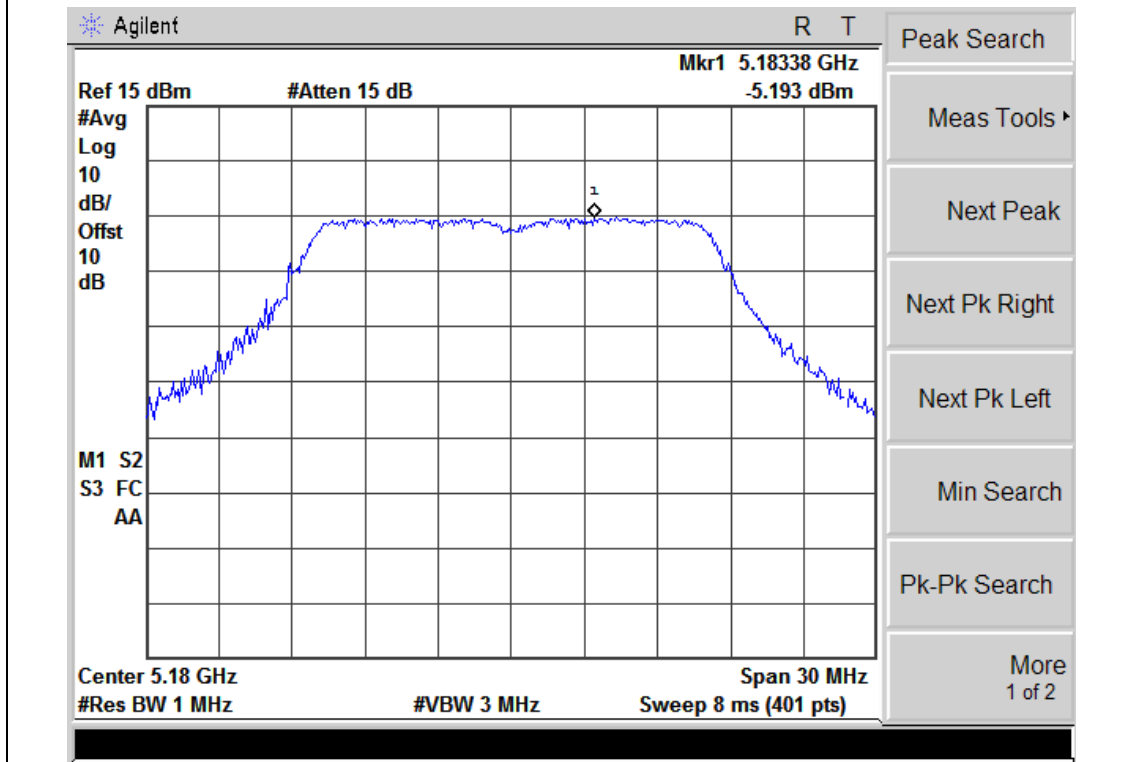



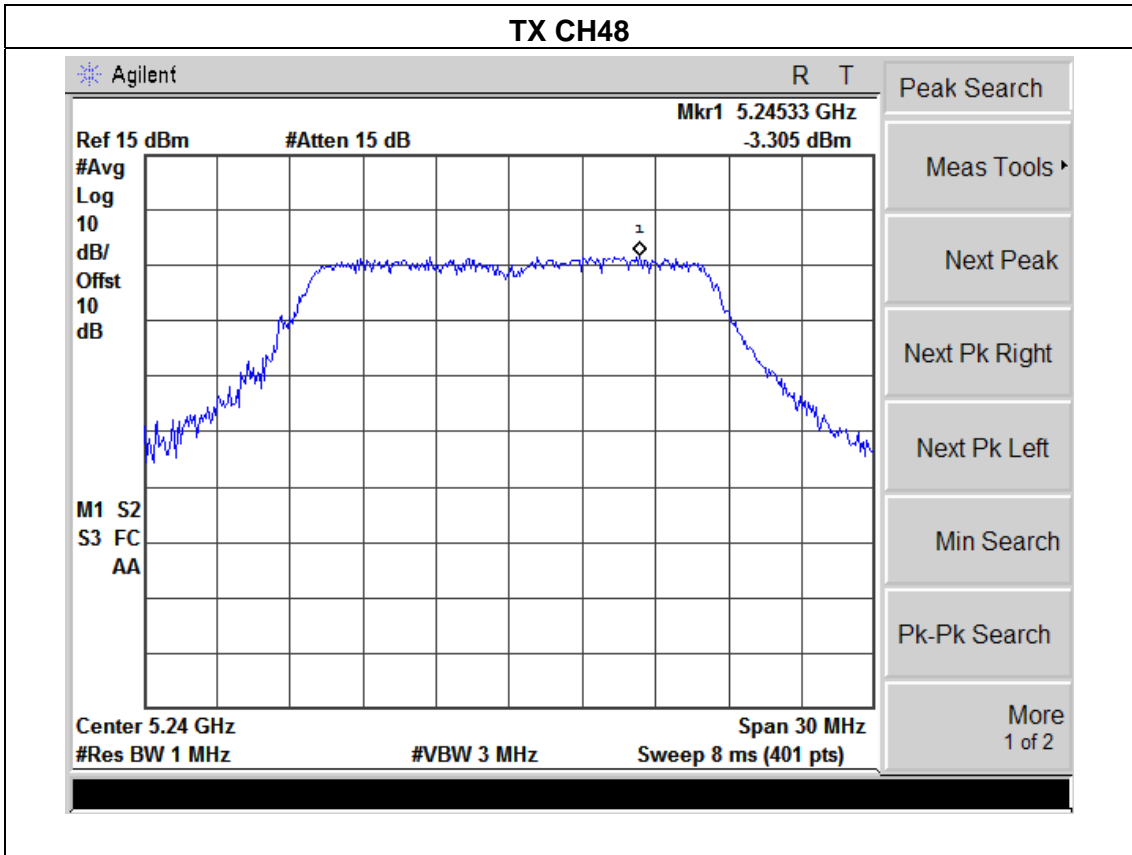
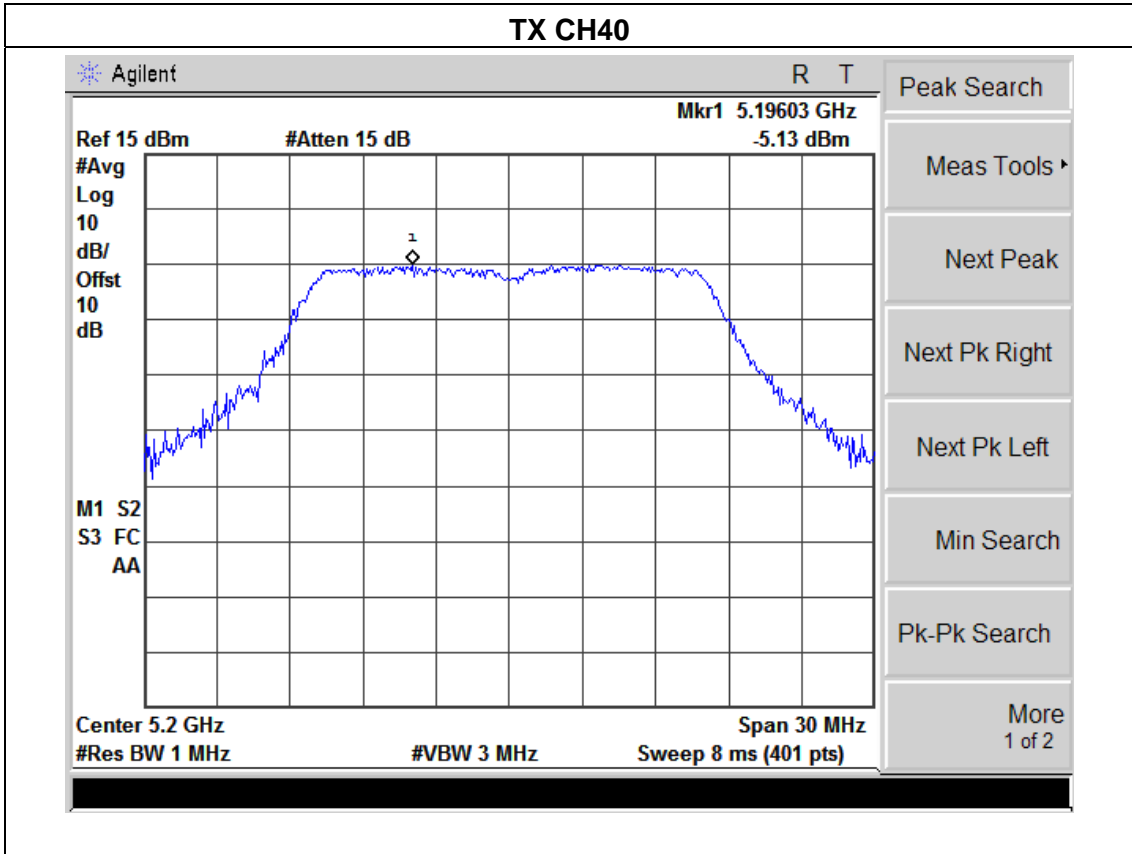

EUT :	ScreenBeam Mini2 Wireless Display Receiver	Model Name :	SBWD60A
Temperature :	25 °C	Relative Humidity :	56%
Pressure :	1015 hPa	Test Voltage :	DC 5V From adapter AC120V/60Hz
Test Mode :	TX n(20) Mode(5G) /CH36, CH40, CH48		

Frequency	Power Density A (dBm)	Power Density B (dBm)	total power density (dBm)	Limit (dBm)	Result
5180 MHz	-3.036	-5.433	-1.061	0.94	PASS
5200 MHz	-3.600	-4.957	-0.881	0.94	PASS
5240 MHz	-1.749	-3.214	0.590	0.94	PASS

The antenna gain of 5 GHz is 9.06 dBi; therefore, the power spectral density limit is reduced by 3.06 dB

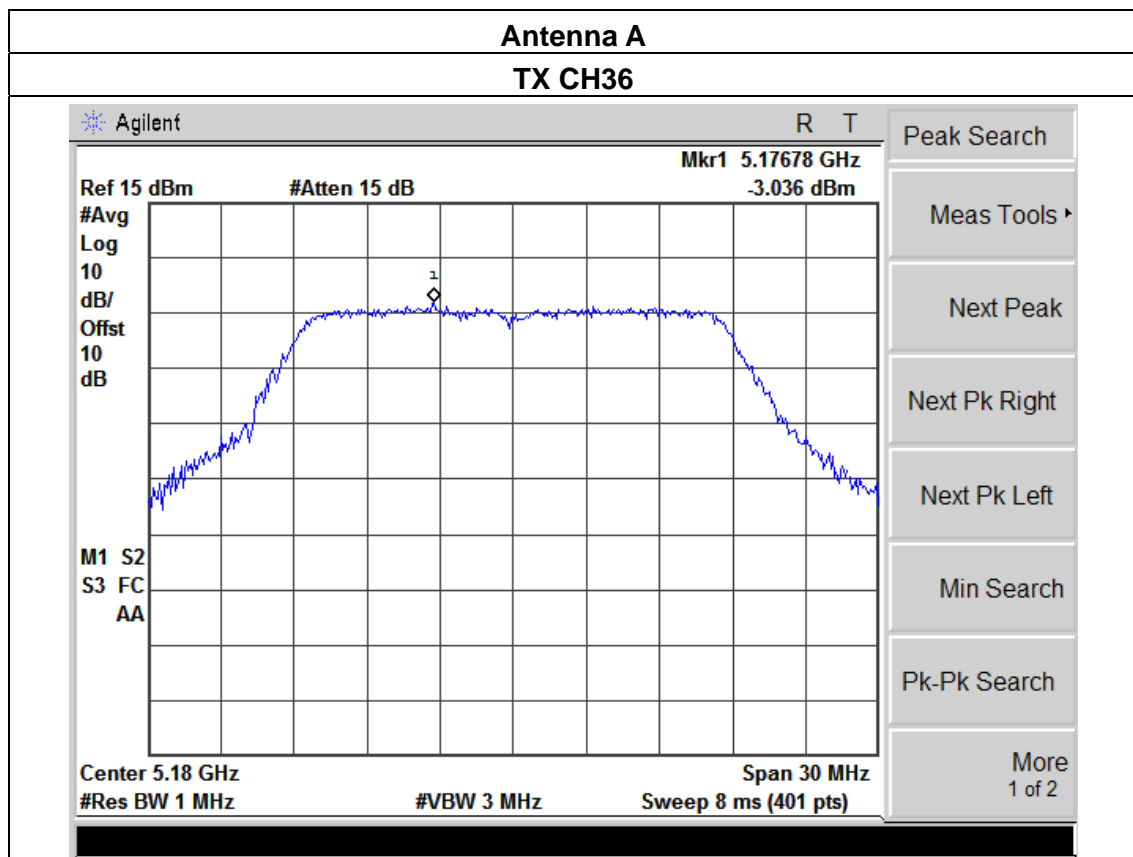

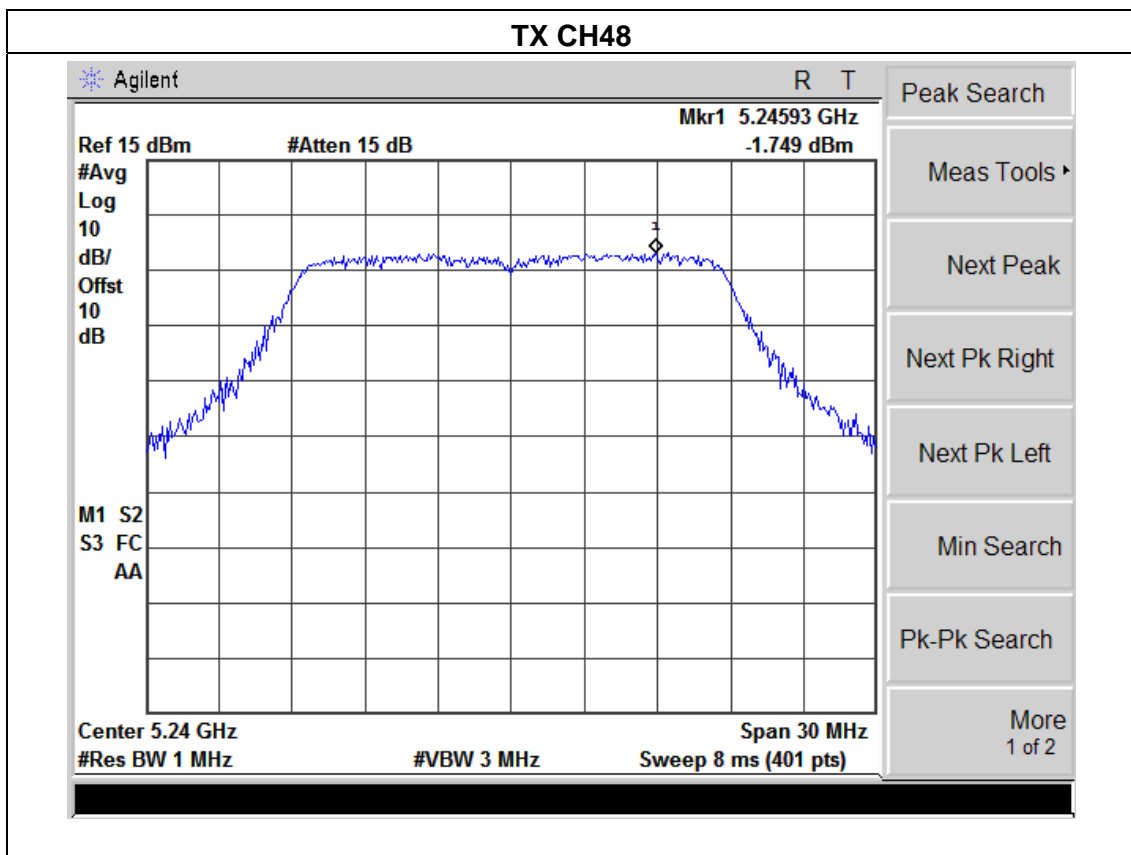
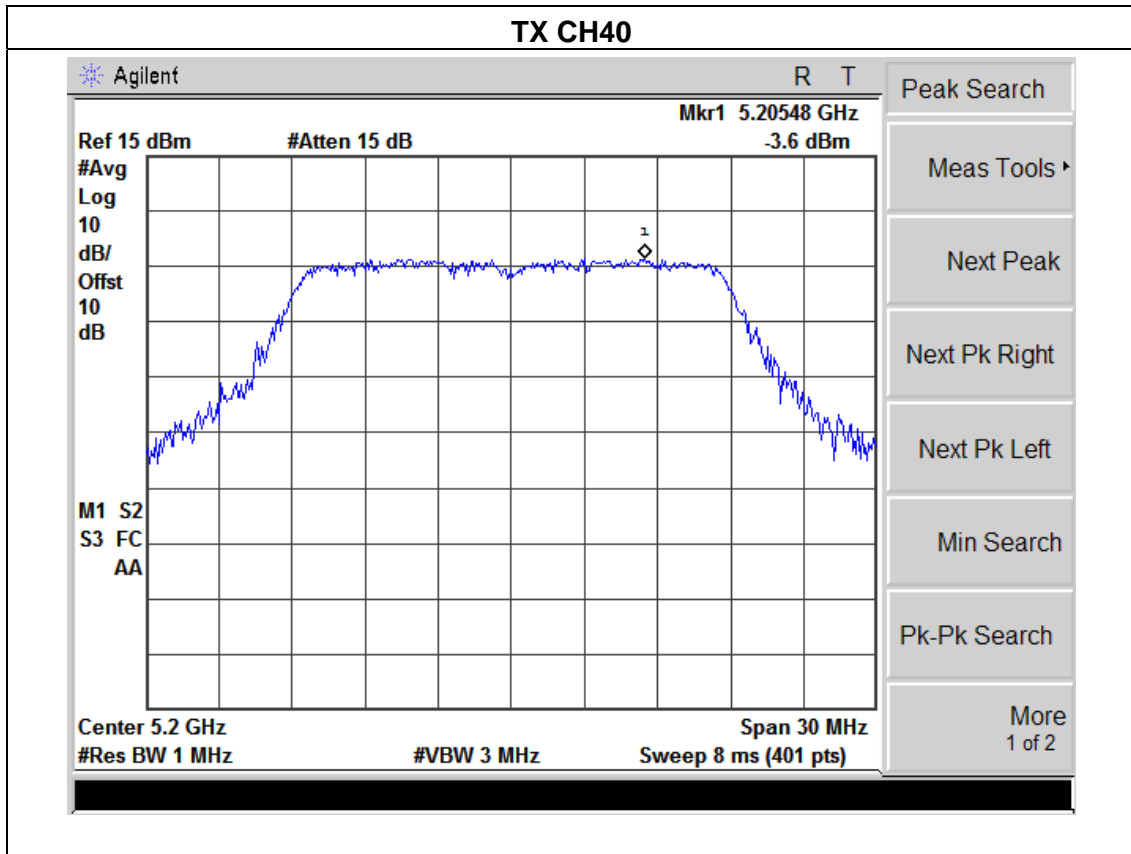

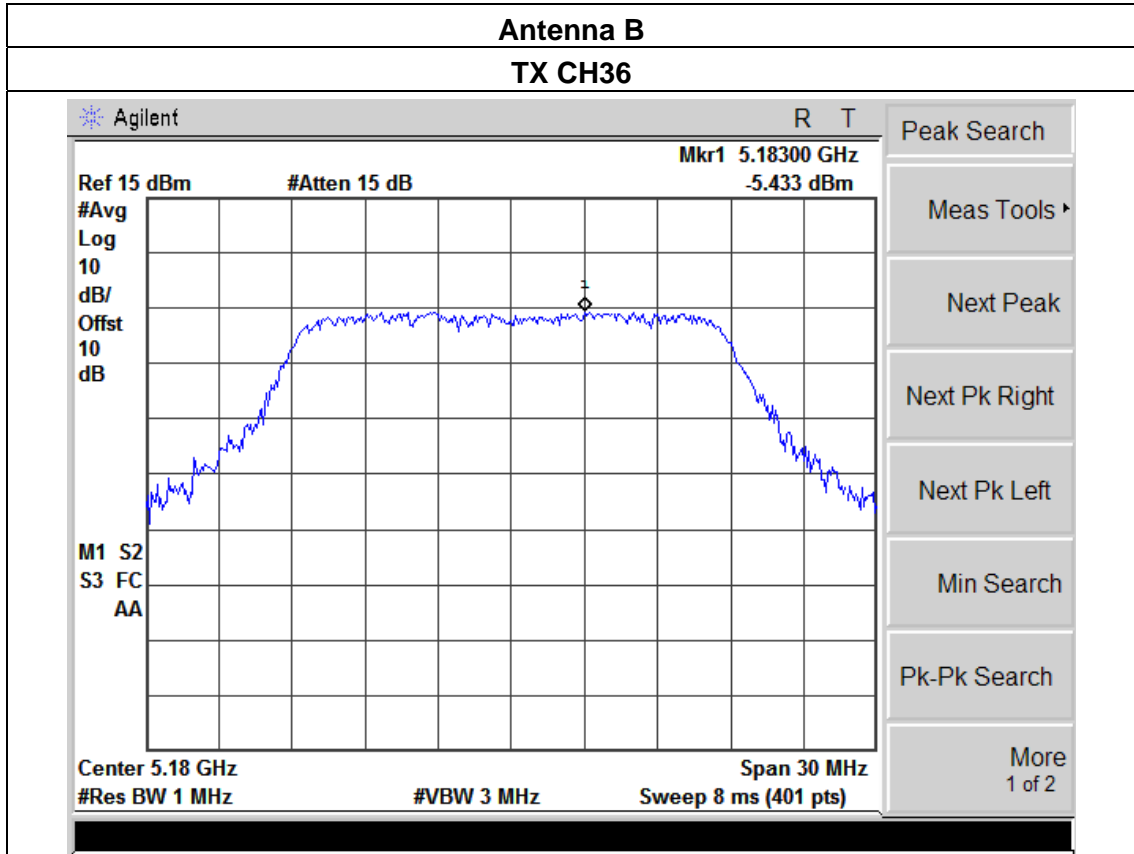

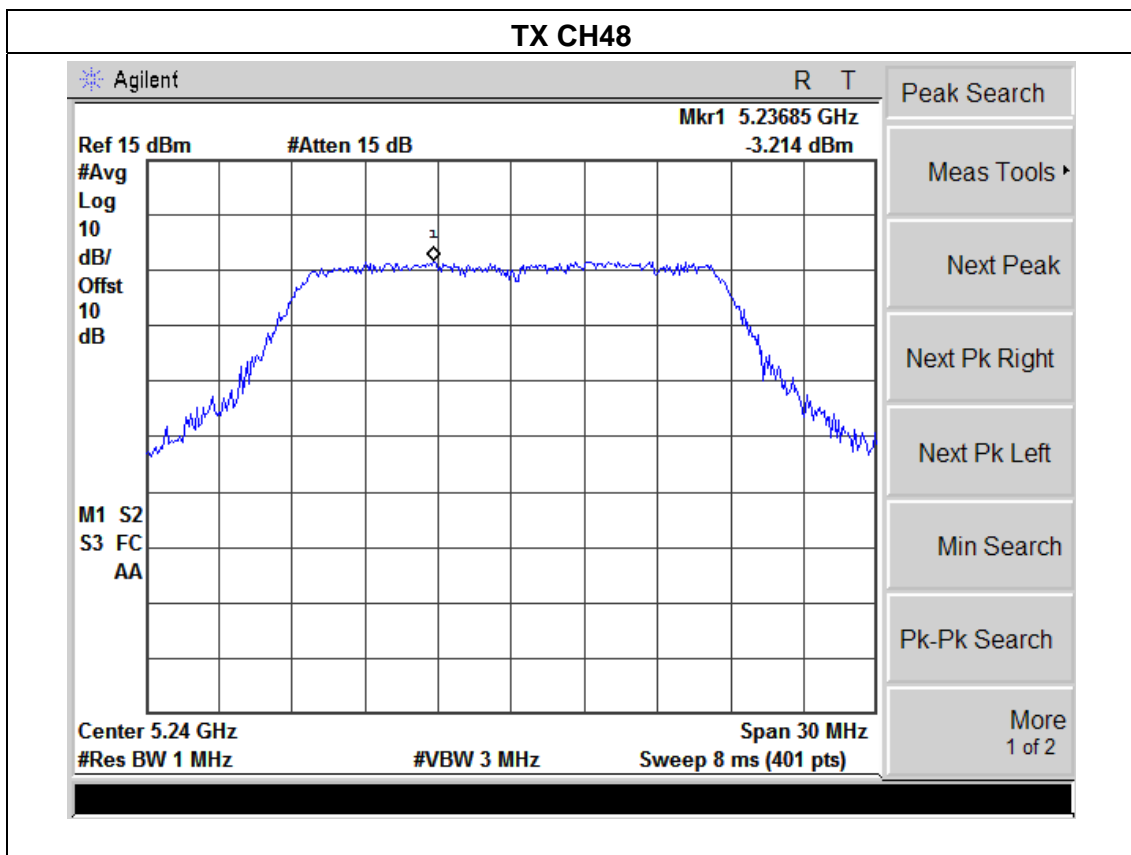
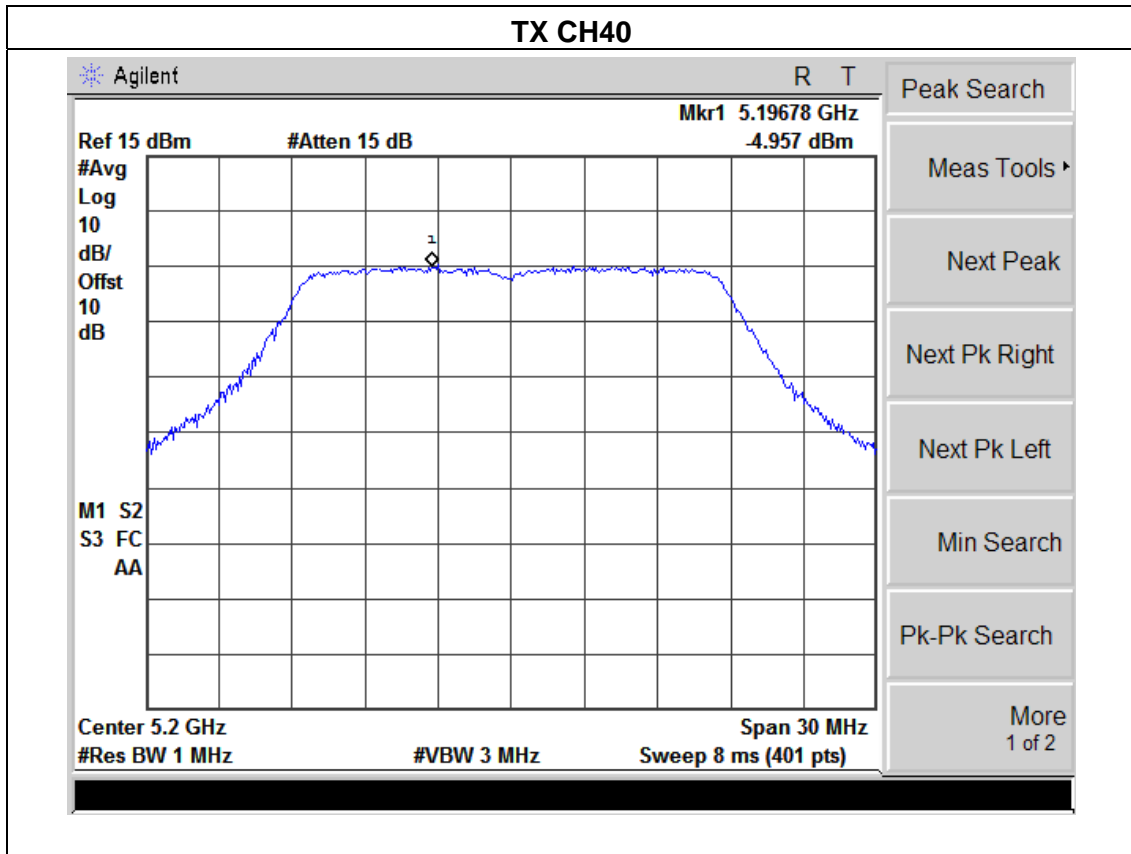

EUT :	ScreenBeam Mini2 Wireless Display Receiver	Model Name :	SBWD60A
Temperature :	25 °C	Relative Humidity :	56%
Pressure :	1015 hPa	Test Voltage :	DC 5V From adapter AC120V/60Hz
Test Mode :	TX n40 Mode(5G) /CH38, CH46		

Frequency	Power Density A (dBm)	Power Density B (dBm)	total power density (dBm)	Limit (dBm)	Result
5190 MHz	-5.722	-6.915	-3.267	0.94	PASS
5230 MHz	-5.036	-5.997	-2.847	0.94	PASS

The antenna gain of 5 GHz is 9.06 dBi; therefore, the power spectral density limit is reduced by 3.06 dB

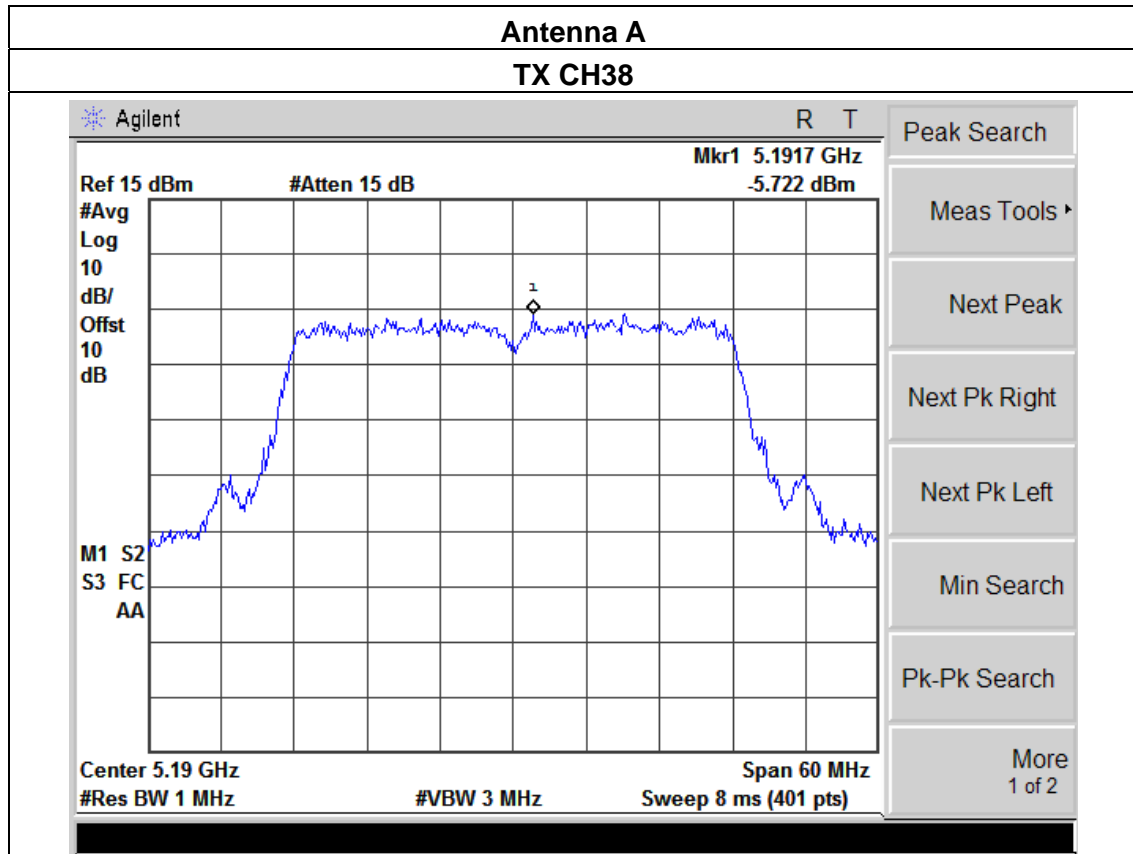

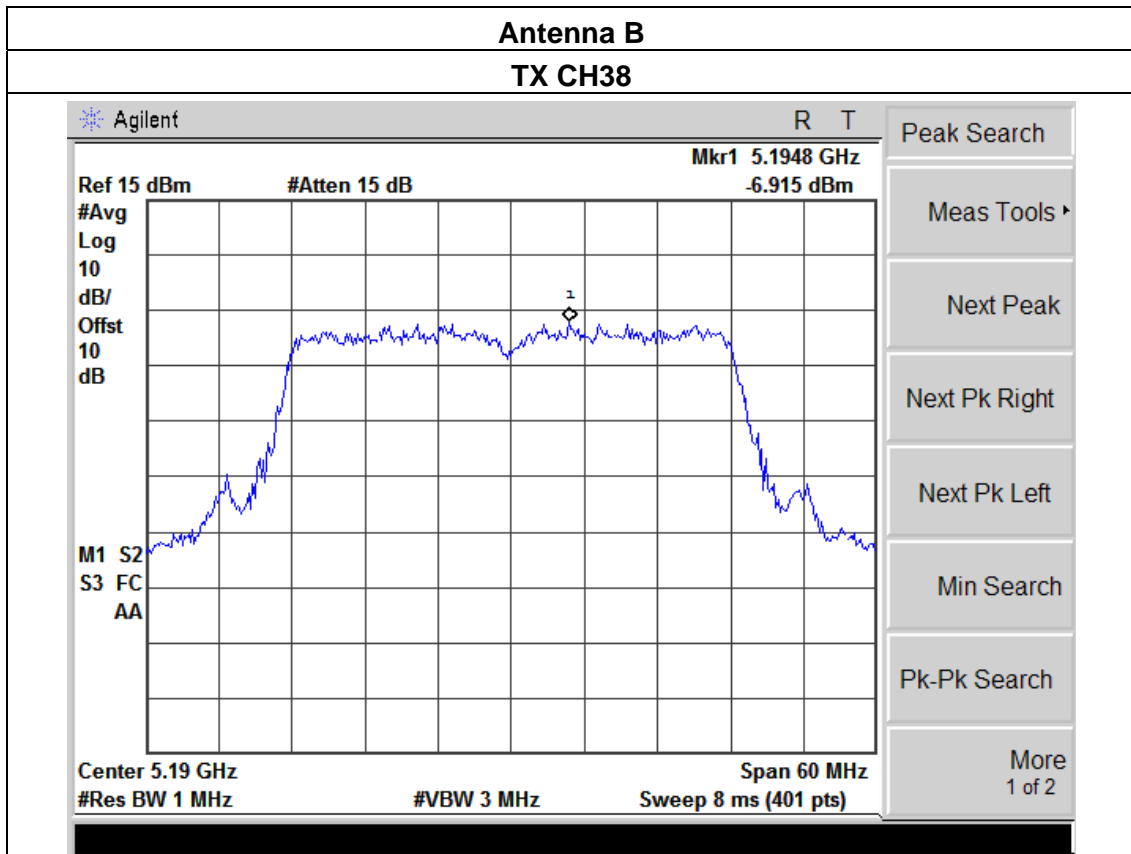
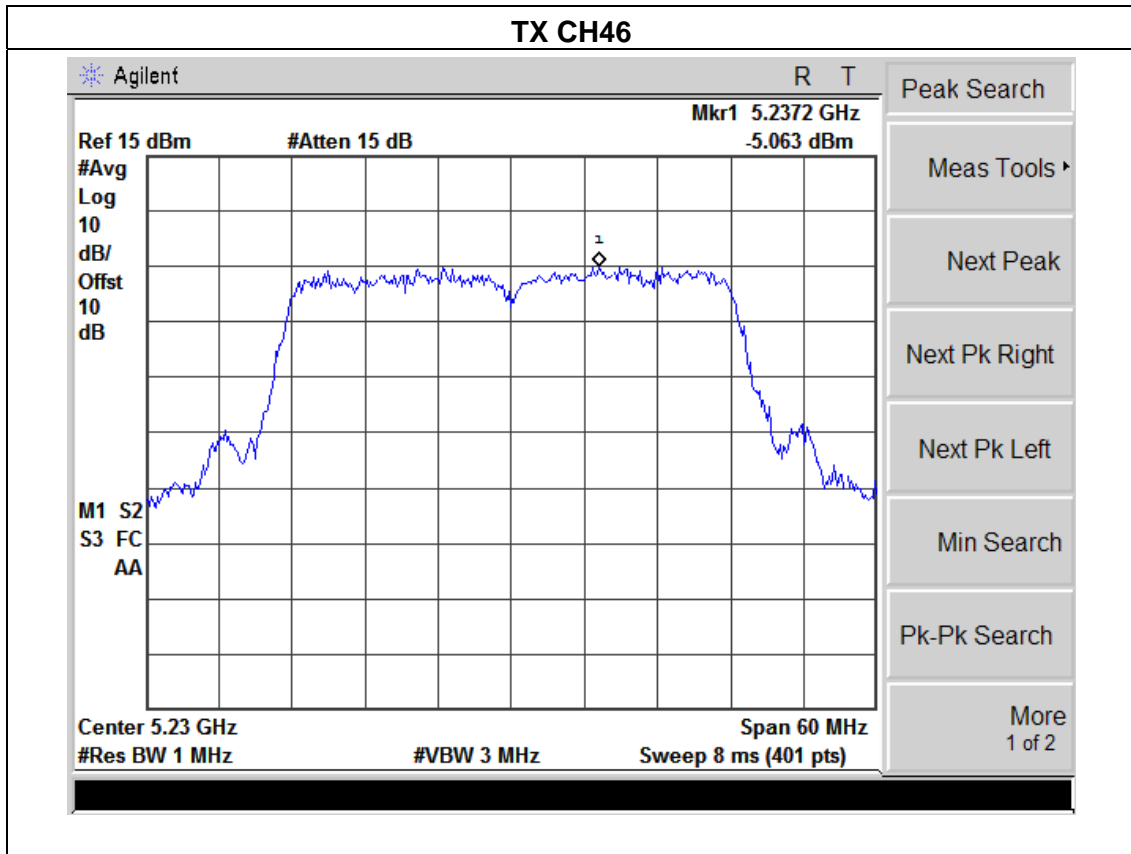

### TX CH46

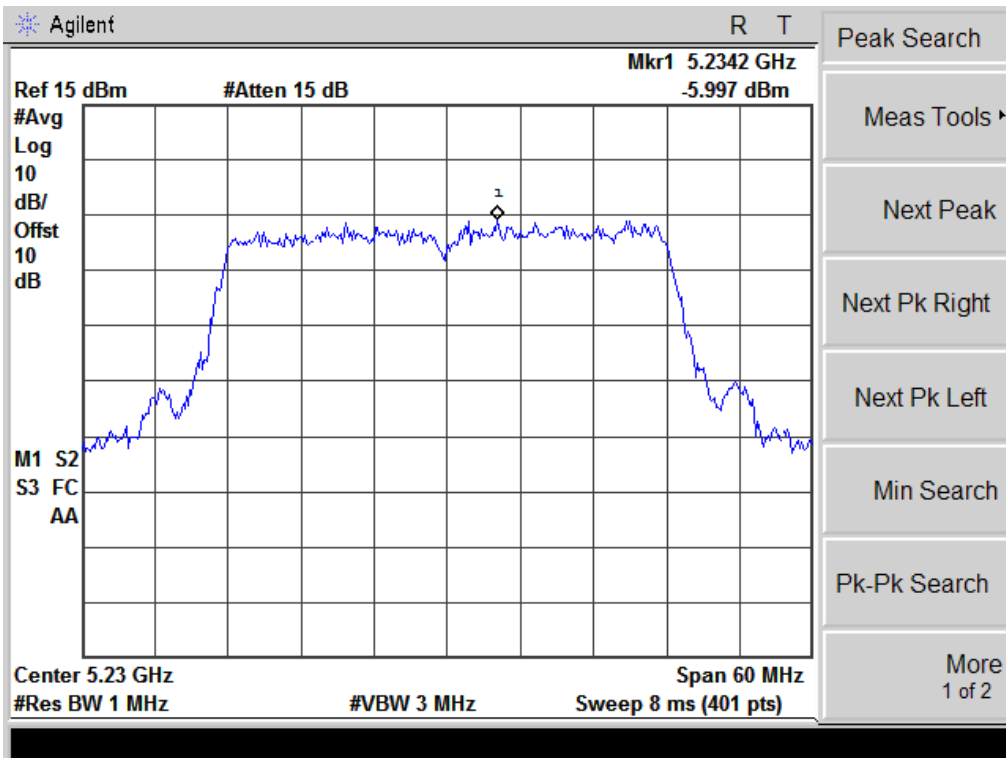



## 5. 26 DB & 99% EMISSION BANDWIDTH

### 5.1 APPLIED PROCEDURES / LIMIT

FCC §15.407(a) and IC RSS-210 §A9.2.

#### 5.1.1 TEST PROCEDURE

1. Check the calibration of the measuring instrument using either an internal calibrator or a known signal from an external generator.
2. Position the EUT without connection to measurement instrument. Turn on the EUT and connect it to measurement instrument. Then set it to any one convenient frequency within its operating range. Set a reference level on the measuring instrument equal to the highest peak value.
3. Measure the frequency difference of two frequencies that were attenuated 26 dB from the reference level. Record the frequency difference as the emissions bandwidth.
4. Repeat above procedures until all frequencies measured were complete.

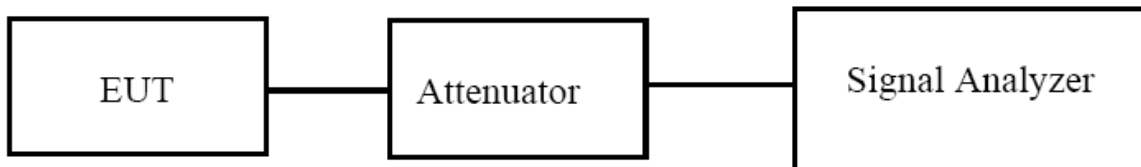

#### 5.1.2 EUT OPERATION CONDITIONS

The EUT tested system was configured as the statements of 2.4 Unless otherwise a special operating condition is specified in the follows during the testing.

### 5.1.3 TEST RESULTS

EUT :	ScreenBeam Mini2 Wireless Display Receiver	Model Name :	SBWD60A
Temperature :	25 °C	Relative Humidity :	56%
Pressure :	1012 hPa	Test Voltage :	DC 5V From adapter AC120V/60Hz
Test Mode :	TX a Mode /CH36, CH40, CH48		

Channel	Frequency (MHz)	99% bandwidth (MHz)ANT A	99% bandwidth (MHz)ANT B	26dB bandwidth (MHz)ANT A	26dB bandwidth (MHz)ANT B	Limit (kHz)	Result
802.11a mode							
Low	5180	17.036	16.987	22.837	22.714	500	Pass
Middle	5200	17.007	16.937	22.605	22.534	500	Pass
High	5240	17.009	16.970	22.757	22.463	500	Pass

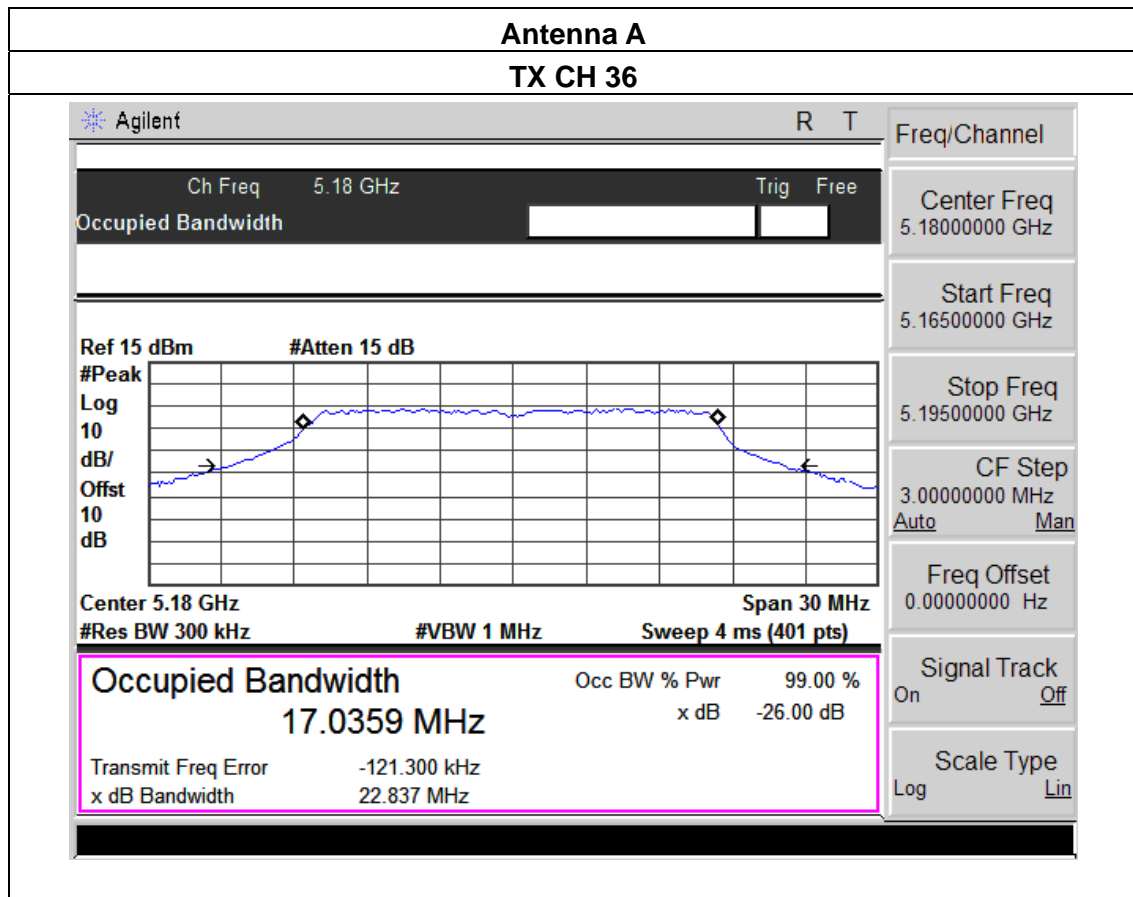

### TX CH 40

Agilent
R T

---

Ch Freq 5.2 GHz
Trig Free

Occupied Bandwidth

---

Ref 15 dBm
#Atten 15 dB

#Peak

Log

10

dB/

Offst

10

dB

Center 5.2 GHz

#Res BW 300 kHz

Span 30 MHz

#VBW 1 MHz

Sweep 4 ms (401 pts)

<b>Occupied Bandwidth</b>	Occ BW % Pwr	99.00 %
<b>17.0067 MHz</b>	x dB	-26.00 dB
Transmit Freq Error	-118.367 kHz	
x dB Bandwidth	22.605 MHz	

Freq/Channel	
Center Freq	5.20000000 GHz
Start Freq	5.18500000 GHz
Stop Freq	5.21500000 GHz
CF Step	3.00000000 MHz
	<u>Auto</u> <u>Man</u>
Freq Offset	0.00000000 Hz
Signal Track	<u>On</u> <u>Off</u>
Scale Type	Log <u>Lin</u>

### TX CH 48

Agilent
R T

---

Ch Freq 5.24 GHz
Trig Free

Occupied Bandwidth

---

Ref 15 dBm
#Atten 15 dB

#Peak

Log

10

dB/

Offst

10

dB

Center 5.24 GHz

#Res BW 300 kHz

Span 30 MHz

#VBW 1 MHz

Sweep 4 ms (401 pts)

<b>Occupied Bandwidth</b>	Occ BW % Pwr	99.00 %
<b>17.0088 MHz</b>	x dB	-26.00 dB
Transmit Freq Error	-104.106 kHz	
x dB Bandwidth	22.757 MHz	

Freq/Channel	
Center Freq	5.24000000 GHz
Start Freq	5.22500000 GHz
Stop Freq	5.25500000 GHz
CF Step	3.00000000 MHz
	<u>Auto</u> <u>Man</u>
Freq Offset	0.00000000 Hz
Signal Track	<u>On</u> <u>Off</u>
Scale Type	Log <u>Lin</u>

**Antenna B**

**TX CH 36**

Agilent
R T

---

Ch Freq 5.18 GHz

Occupied Bandwidth

Trig Free

---

Ref 15 dBm #Atten 15 dB

Center 5.18 GHz Span 30 MHz

#Res BW 300 kHz #VBW 1 MHz Sweep 4 ms (401 pts)

Freq/Channel

Center Freq 5.1800000 GHz

Start Freq 5.1650000 GHz

Stop Freq 5.1950000 GHz

CF Step 3.0000000 MHz

Auto Man

Freq Offset 0.0000000 Hz

Signal Track On Off

Scale Type Log Lin

---

**Occupied Bandwidth** Occ BW % Pwr 99.00 %

**16.9868 MHz**

x dB -26.00 dB

Transmit Freq Error -108.452 kHz

x dB Bandwidth 22.714 MHz

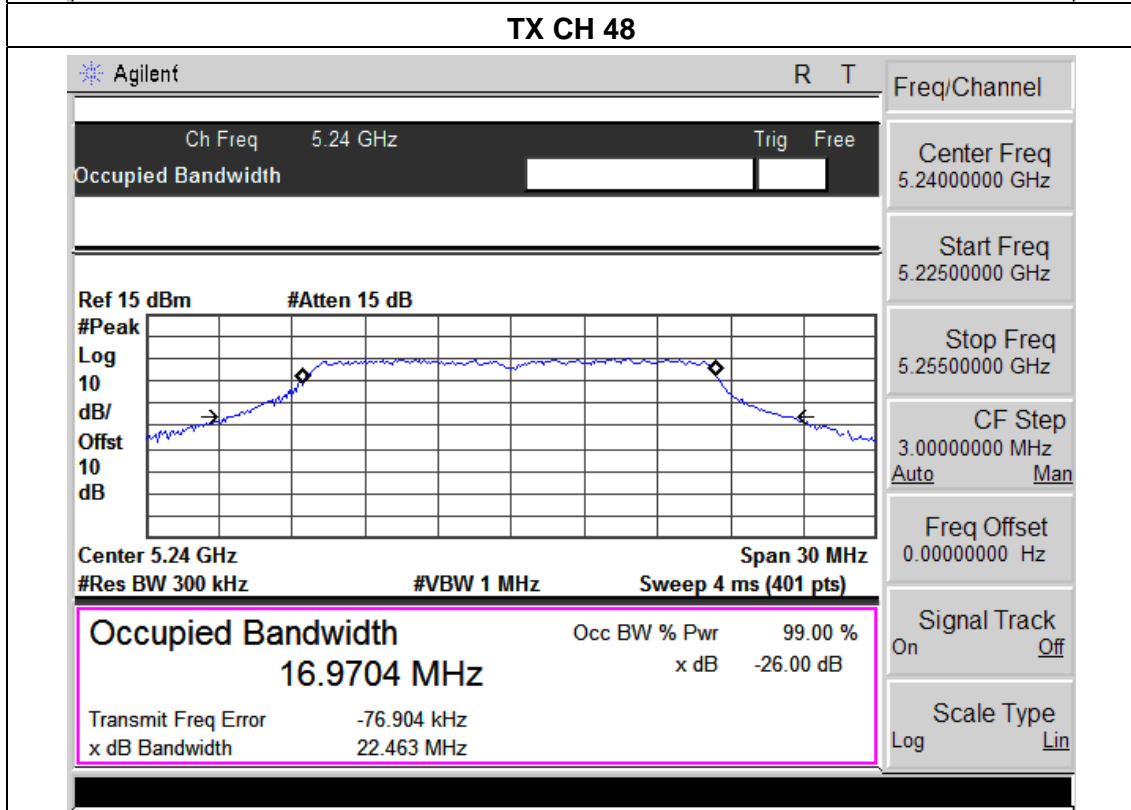
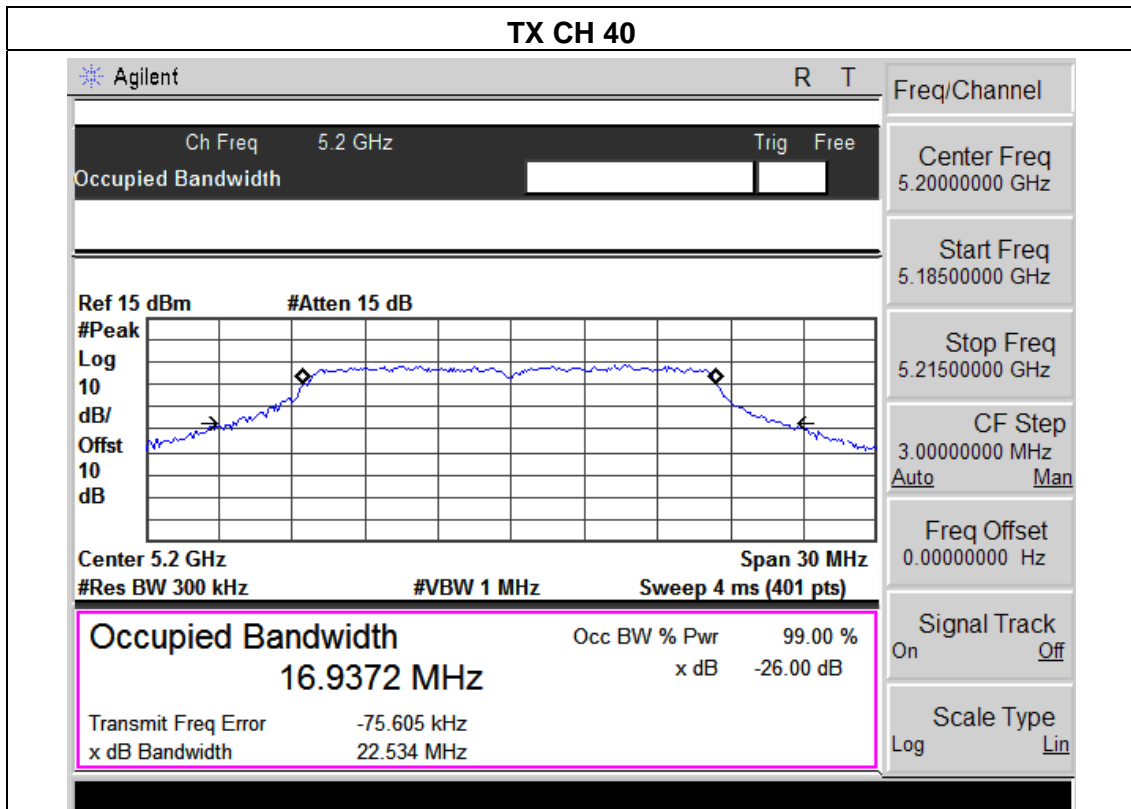

EUT :	ScreenBeam Mini2 Wireless Display Receiver	Model Name :	SBWD60A
Temperature :	25 °C	Relative Humidity :	56%
Pressure :	1012 hPa	Test Voltage :	DC 5V From adapter AC120V/60Hz
Test Mode :	TX n(20) Mode(5G) /CH36, CH40, CH48		

Channel	Frequency (MHz)	99% bandwidth (MHz)ANT A	99% bandwidth (MHz)ANT B	26dB bandwidth (MHz)ANT A	26dB bandwidth (MHz) ANT B	Limit (kHz)	Result
802.11N20 mode							
Low	5180	18.000	17.979	23.771	23.638	500	Pass
Middle	5200	18.048	18.024	23.806	23.752	500	Pass
High	5240	18.027	17.979	23.894	23.811	500	Pass

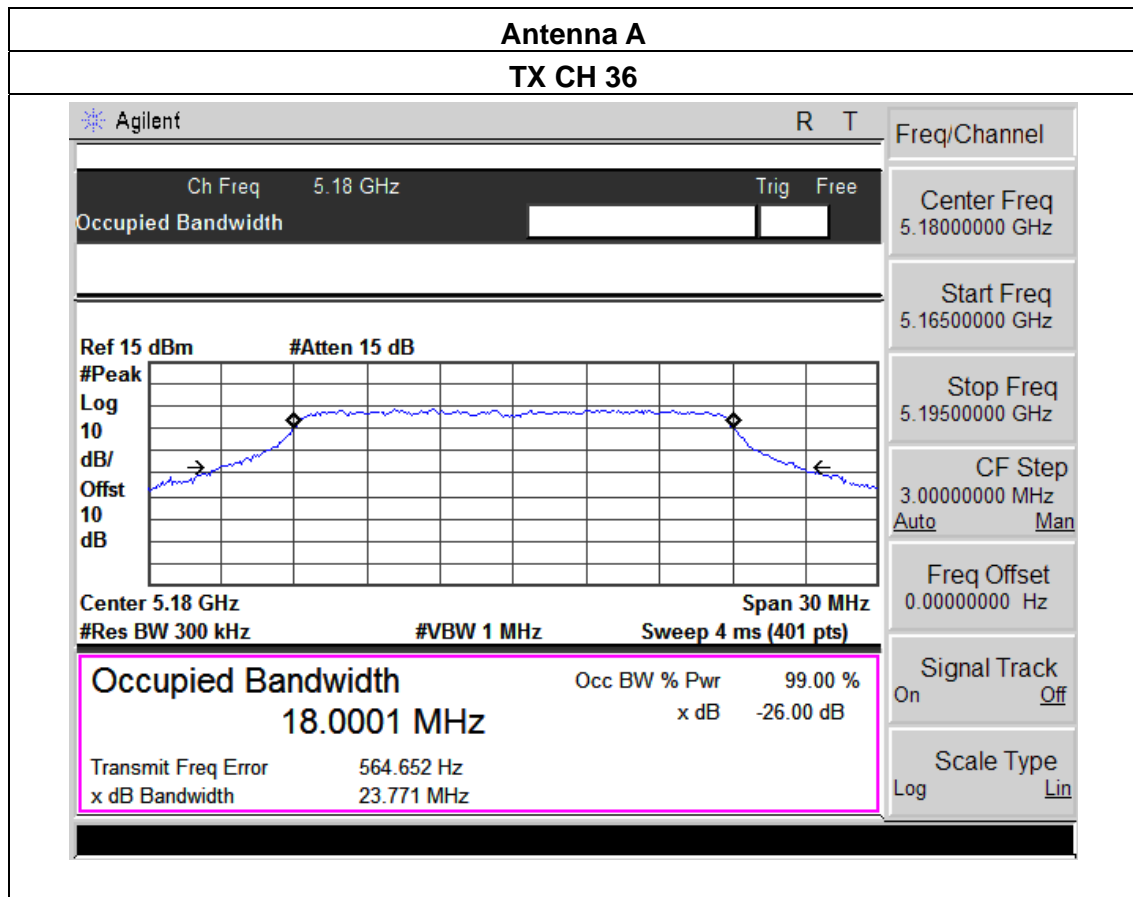

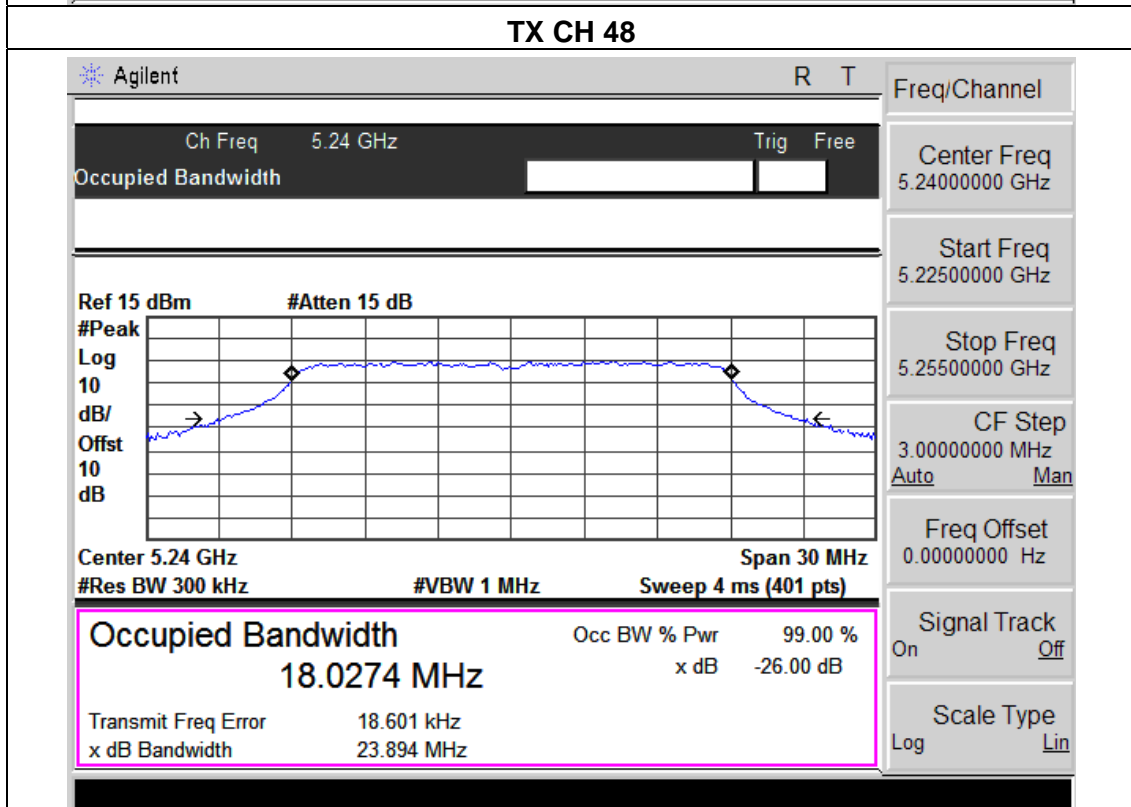
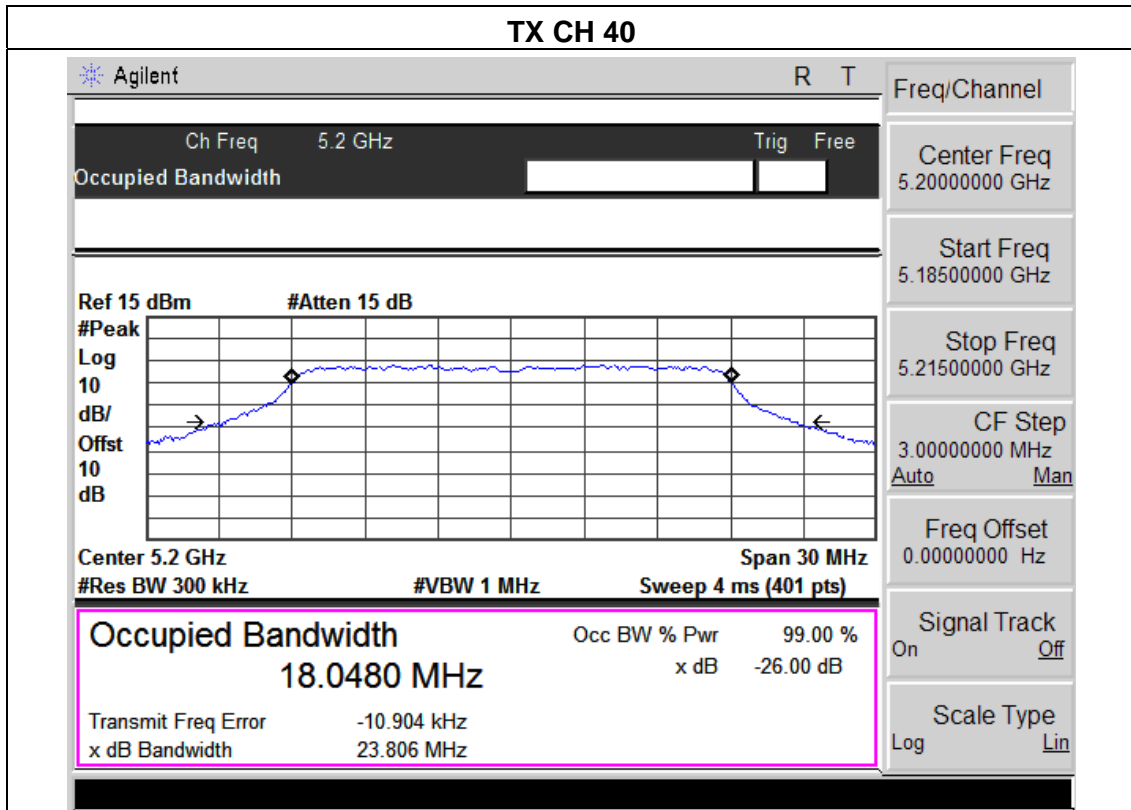

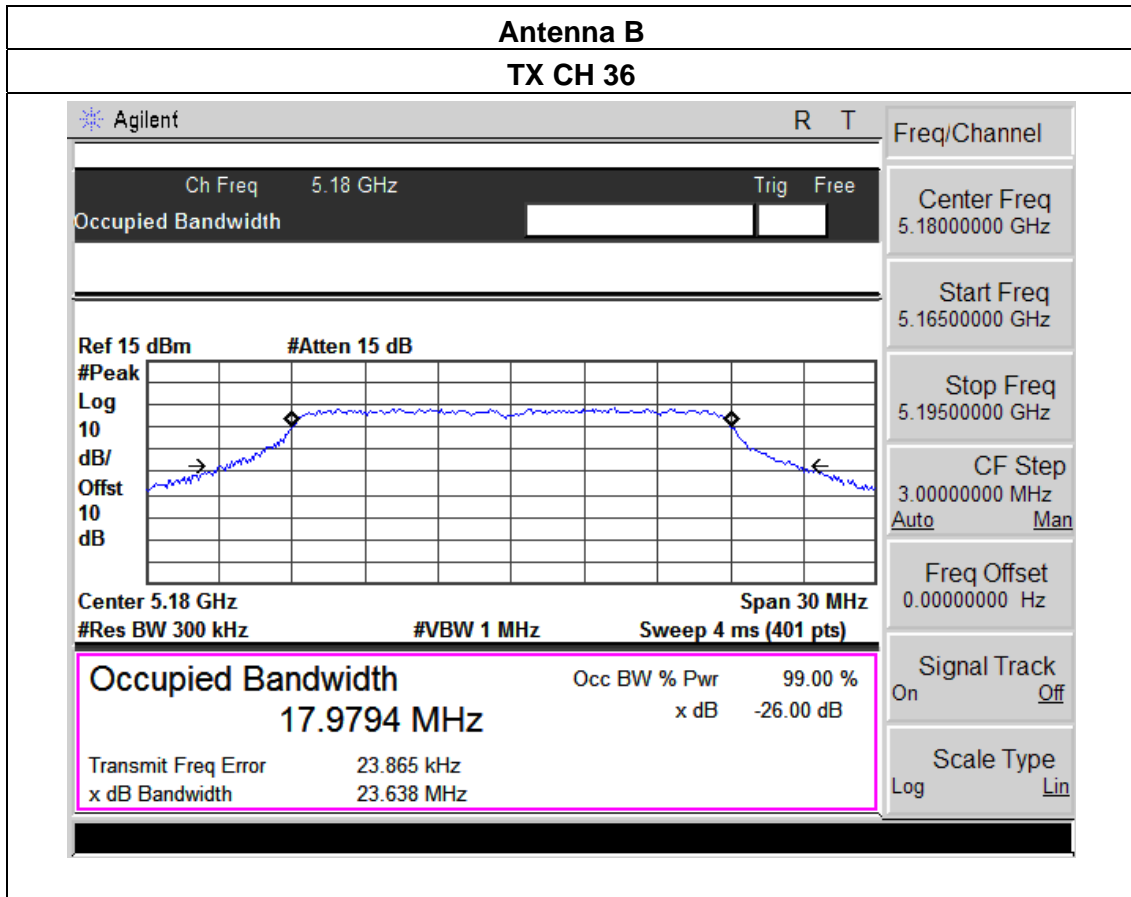



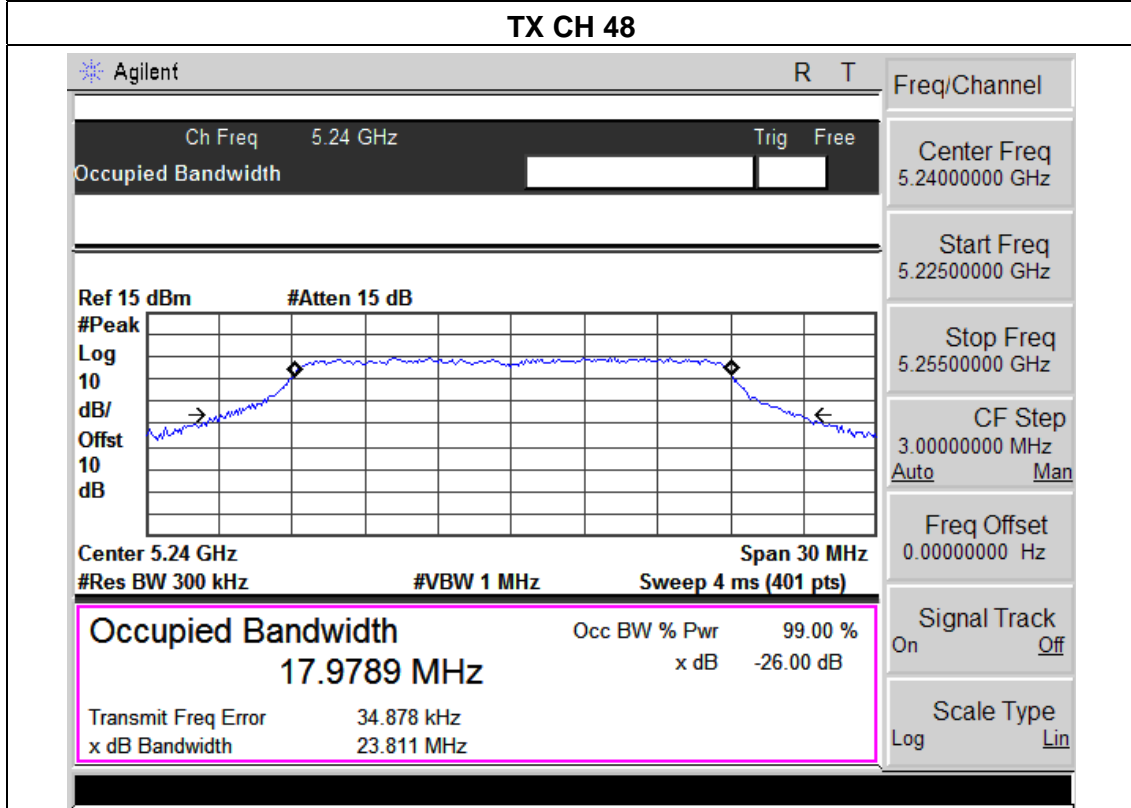
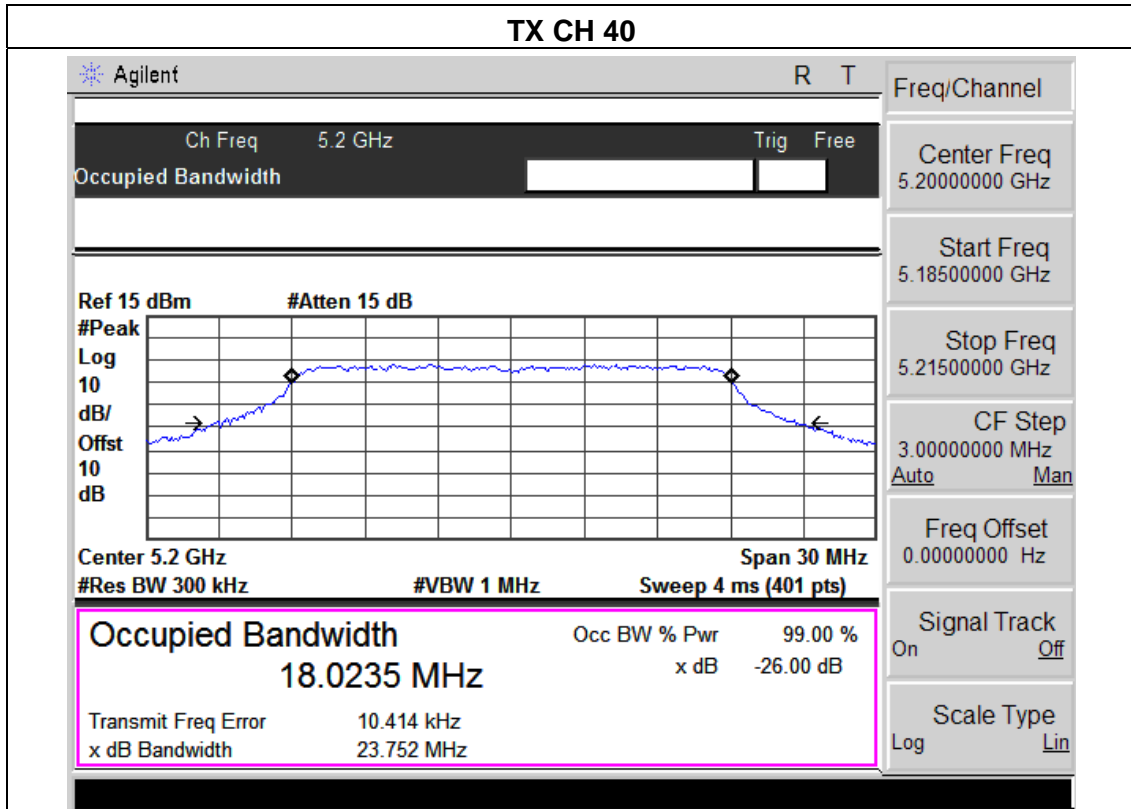

EUT :	ScreenBeam Mini2 Wireless Display Receiver	Model Name :	SBWD60A
Temperature :	25 °C	Relative Humidity :	56%
Pressure :	1012 hPa	Test Voltage :	DC 5V From adapter AC120V/60Hz
Test Mode :	TX n40 Mode(5G) /CH38, CH46		

Channel	Frequency (MHz)	99% bandwidth (MHz)ANT A	99% bandwidth (MHz)ANT B	26dB bandwidth (MHz)ANT A	26dB bandwidth (MHz) ANT B	Limit (kHz)	Result
802.11N40 mode							
Low	5190	36.655	36.619	42.674	42.396	500	Pass
High	5230	36.640	36.377	42.428	41.627	500	Pass

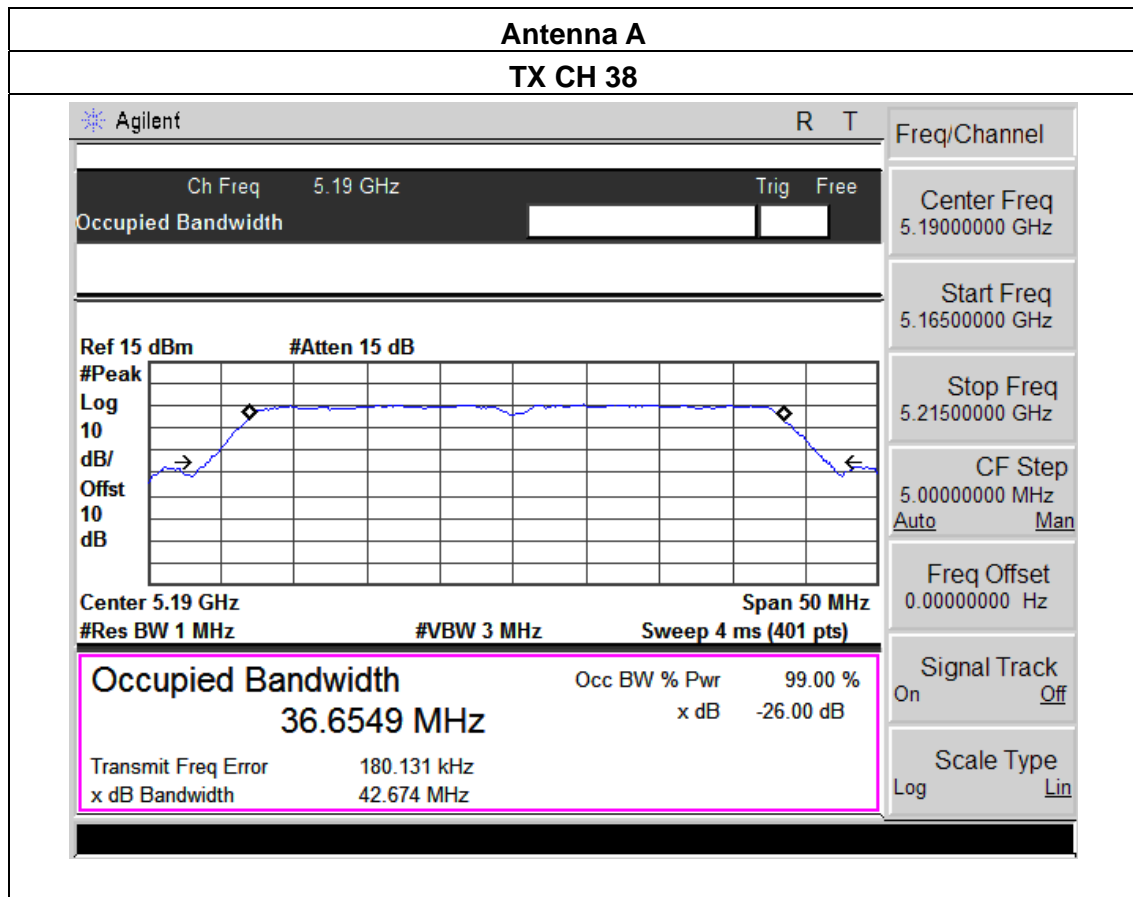

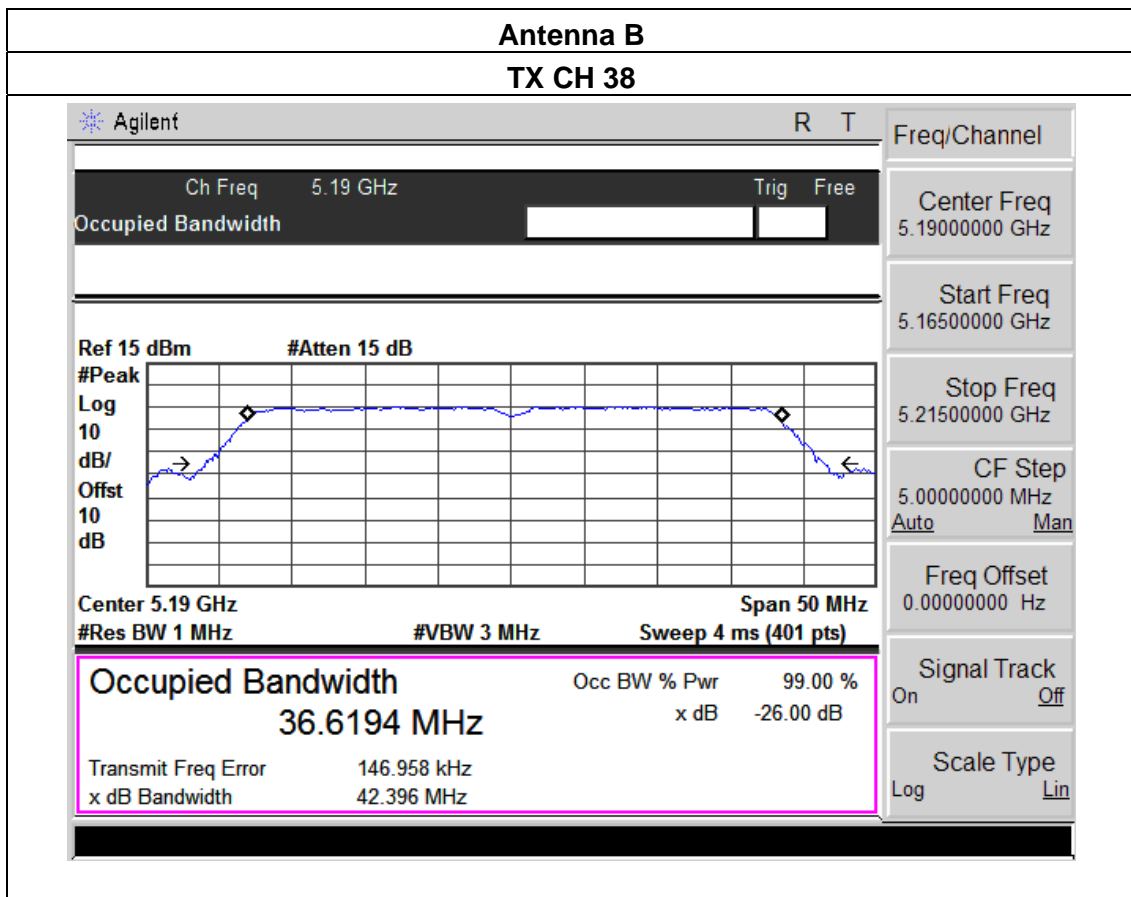
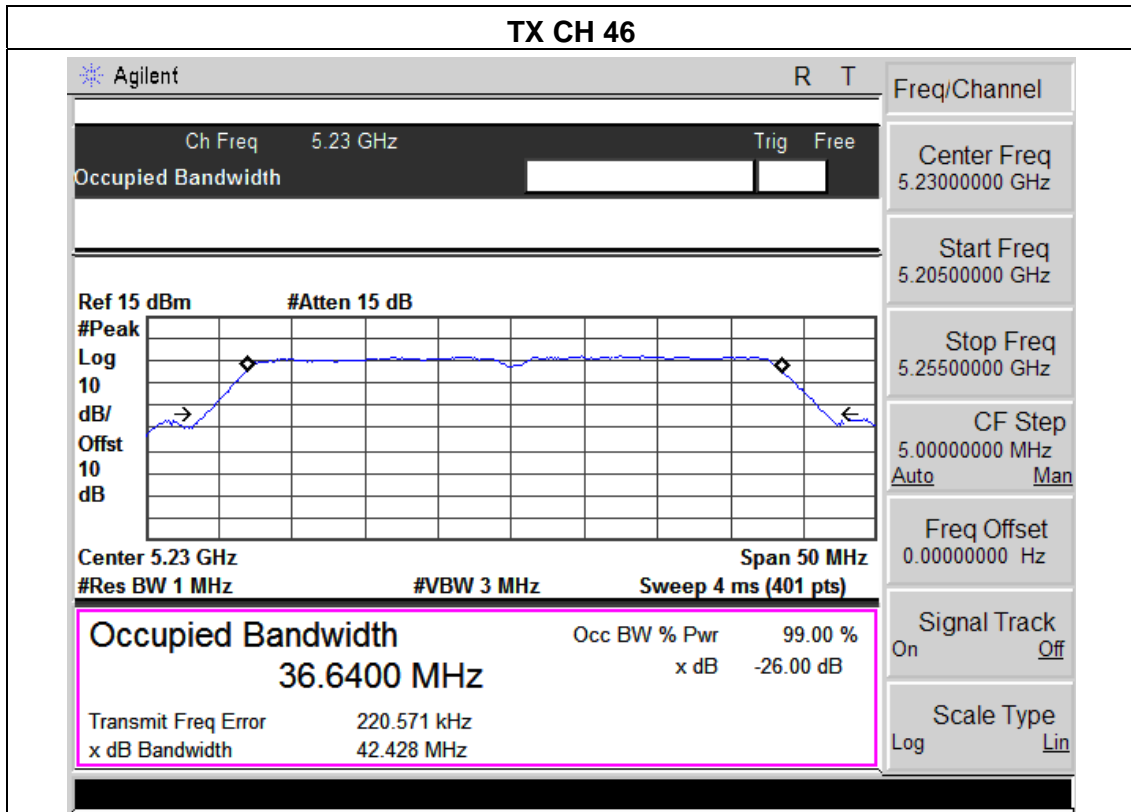

**TX CH 46**

Agilent		R	T	Freq/Channel	
Ch Freq 5.23 GHz		Trig Free		Center Freq 5.23000000 GHz	
Occupied Bandwidth				Start Freq 5.20500000 GHz	
Ref 15 dBm #Atten 15 dB				Stop Freq 5.25500000 GHz	
				CF Step 5.00000000 MHz Auto Man	
Center 5.23 GHz		Span 50 MHz		Freq Offset 0.00000000 Hz	
#Res BW 1 MHz		#VBW 3 MHz		Sweep 4 ms (401 pts)	
<b>Occupied Bandwidth</b> <b>36.3772 MHz</b>		Occ BW % Pwr 99.00 %		Signal Track On Off	
		x dB -26.00 dB		Scale Type Log Lin	
Transmit Freq Error 142.851 kHz					
x dB Bandwidth 41.627 MHz					

## 6. PEAK OUTPUT POWER TEST

### 6.1 APPLIED PROCEDURES / LIMIT

#### According to FCC §15.407(a)(1)

For the band 5.15–5.25 GHz, the maximum conducted output power over the frequency band of operation shall not exceed the lesser of 50 mW or  $4 \text{ dBm} + 10 \log B$ , where B is the 26-dB emission bandwidth in MHz. In addition, the peak power spectral density shall not exceed 4 dBm in any 1-MHz band. If transmitting antennas of directional gain greater than 6 dBi are used, both the maximum conducted output power and the peak power spectral density shall be reduced by the amount in dB that the directional gain of the antenna exceeds 6 dBi.

For the 5.25–5.35 GHz and 5.47–5.725 GHz bands, the maximum conducted output power over the frequency bands of operation shall not exceed the lesser of 250 mW or  $11 \text{ dBm} + 10 \log B$ , where B is the 26 dB emission bandwidth in megahertz. In addition, the peak power spectral density shall not exceed 11 dBm in any 1 megahertz band. If transmitting antennas of directional gain greater than 6 dBi are used, both the maximum conducted output power and the peak power spectral density shall be reduced by the amount in dB that the directional gain of the antenna exceeds 6 dBi.

#### According to IC RSS-210 §A9.2:

For the 5.15–5.250 GHz bands, the maximum e.i.r.p shall not exceed 200 mW or  $10 + 10 \log B$ , whichever power is less. B is the 99% emission bandwidth in MHz. The e.i.r.p spectral density shall not exceed 10 dBm in any 1.0 MHz band.

#### 6.1.1 TEST PROCEDURE

- a. The EUT was directly connected to the Power meter

#### 6.1.2 DEVIATION FROM STANDARD

No deviation.

#### 6.1.3 TEST SETUP

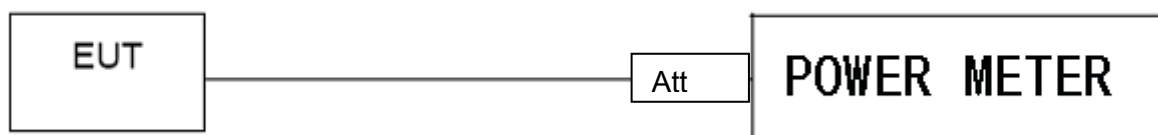

#### 6.1.4 EUT OPERATION CONDITIONS

The EUT tested system was configured as the statements of 2.4 Unless otherwise a special operating condition is specified in the follows during the testing.

### 6.1.5 TEST RESULTS

EUT :	ScreenBeam Mini2 Wireless Display Receiver	Model Name :	SBWD60A
Temperature :	25 °C	Relative Humidity :	60%
Pressure :	1012 hPa	Test Voltage :	DC 5V From adapter AC120V/60Hz
Test Mode :	TX a/n(5G) Mode		

Test Channel	Frequency (MHz)	Maximum output power. Antenna port				Total Power		LIMIT dBm
		(PK) (dBm)		(AV) (dBm)		(PK)	(AV)	
		ANT A	ANT B	ANT A	ANT B	dBm	dBm	
<b>TX 802.11a Mode</b>								
CH36	5180	9.69	8.87	6.38	5.63	12.31	9.03	13.94
CH40	5200	9.53	8.75	6.26	5.77	12.26	9.10	13.94
CH48	5240	9.72	8.71	6.11	5.56	12.25	8.85	13.94
<b>TX 802.11 n20M Mode</b>								
CH36	5180	8.52	7.86	5.54	4.35	11.21	8.00	13.94
CH40	5200	8.48	7.82	5.83	4.27	11.19	7.96	13.94
CH48	5240	8.61	7.79	5.35	4.39	11.23	7.91	13.94
<b>TX 802.11 n40M Mode</b>								
CH38	5190	7.52	6.88	4.11	3.72	10.22	6.93	13.94
CH46	5230	7.63	6.93	4.17	3.81	10.25	6.97	13.94

*The antenna gain of 5 GHz is 9.06 dBi; therefore, the power spectral density limit is reduced by 3.06 dB*

**7. OUT OF BAND EMISSIONS**

**APPLICABLE STANDARD**

**According to FCC §15.407(b)**

For transmitters operating in the 5.15–5.25 GHz band: all emissions outside of the 5.15–5.35 GHz band shall not exceed an EIRP of –27 dBm/MHz

**According to RSS-210 §A8.5,**

in any 100 kHz bandwidth outside the frequency band in which the spread spectrum or digitally modulated device is operating, the radio frequency power that is produced shall be at least 20 dB below that in the 100 kHz bandwidth within the band that contains the highest level of the desired power, based on either an RF conducted or a radiated measurement, provided the transmitter demonstrates compliance with the peak conducted power limits. If the transmitter complies with the conducted power limits based on the use of RMS averaging over a time interval, as permitted under section A8.4(4), the attenuation required shall be 30 dB instead of 20 dB. Attenuation below the general limits specified in Tables 2 and 3 is not required.

**TEST PROCEDURE**

1. Check the calibration of the measuring instrument using either an internal calibrator or a known signal from an external generator.
2. Position the EUT without connection to measurement instrument. Turn on the EUT and connect its antenna terminal to measurement instrument via a low loss cable. Then set it to any one measured frequency within its operating range, and make sure the instrument is operated in its linear range.
3. Set RBW of spectrum analyzer to 1 MHz with a convenient frequency span.
4. Measure the highest amplitude appearing on spectral display and set it as a reference level. Plot the graph with marking the highest point and edge frequency.
5. Repeat above procedures until all measured frequencies were complete.

**7.1 DEVIATION FROM STANDARD**

No deviation.

**7.2 TEST SETUP**

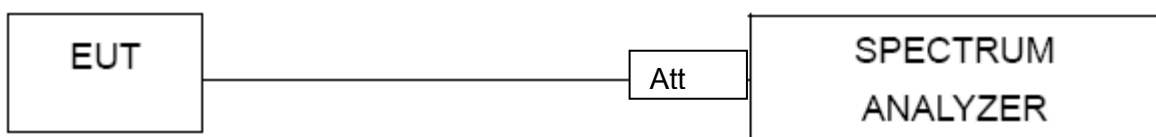

**7.3 EUT OPERATION CONDITIONS**

The EUT tested system was configured as the statements of 2.4 Unless otherwise a special operating condition is specified in the follows during the testing.

**7.4 TEST RESULTS**

EUT :	ScreenBeam Mini2 Wireless Display Receiver	Model Name :	SBWD60A
Temperature :	25 °C	Relative Humidity :	56%
Pressure :	1012 hPa	Test Voltage :	DC 5V From adapter AC120V/60Hz



Antenna A

802.11a: Band Edge, Right Side

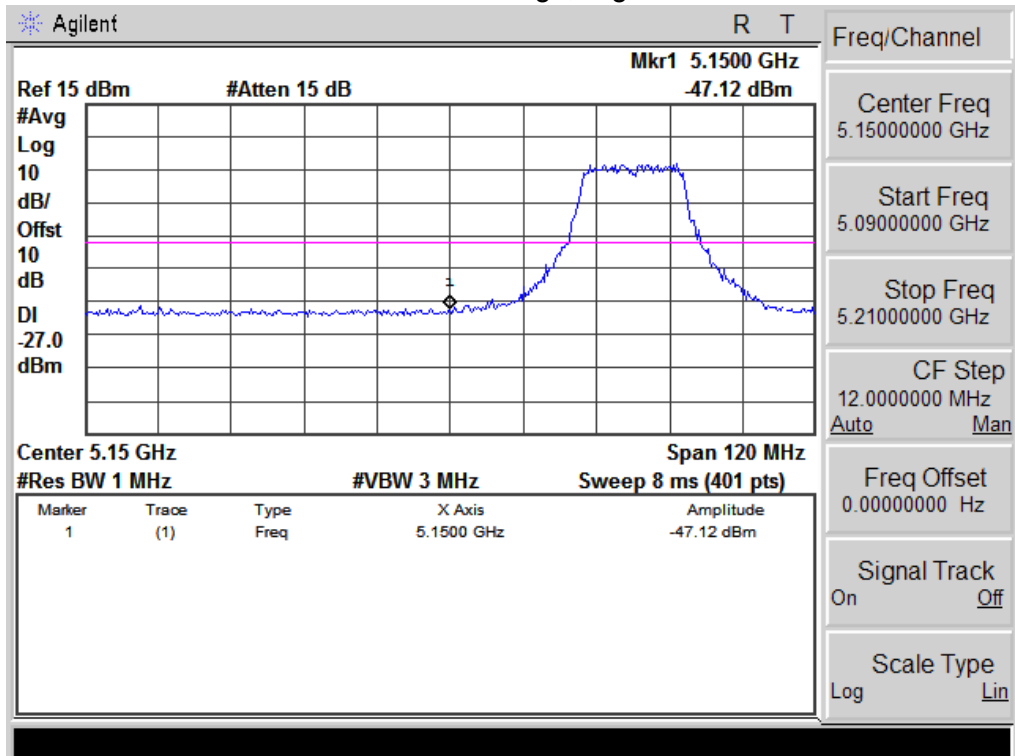

802.11a: Band Edge, Left Side

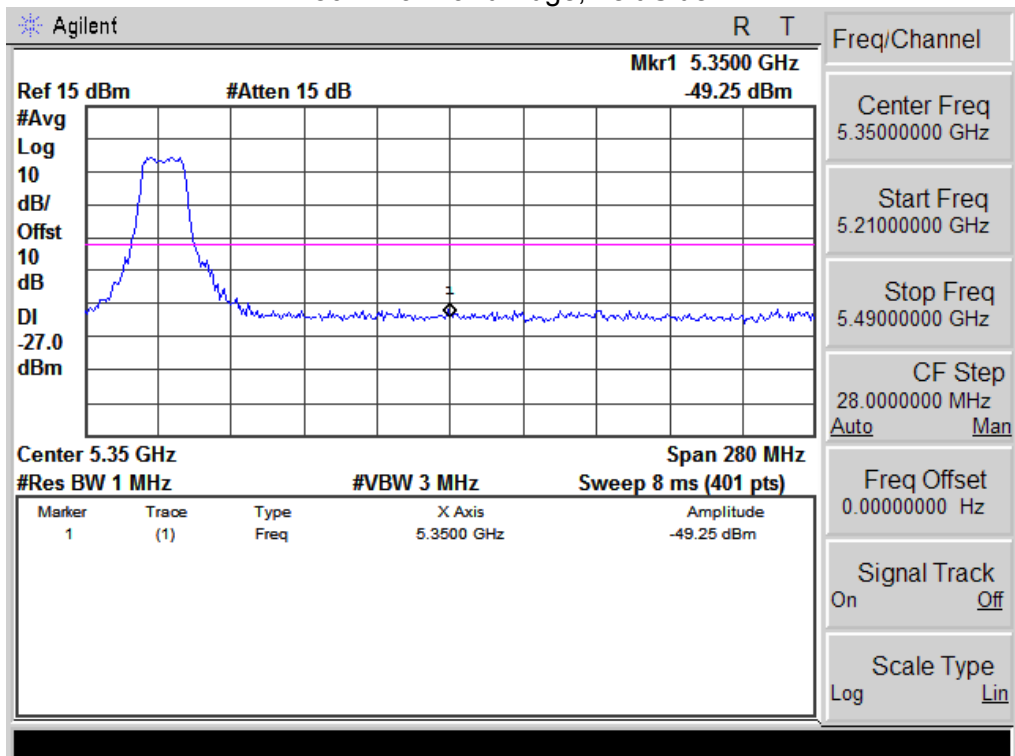

### 802.11 n20(5G): Band Edge, Right Side

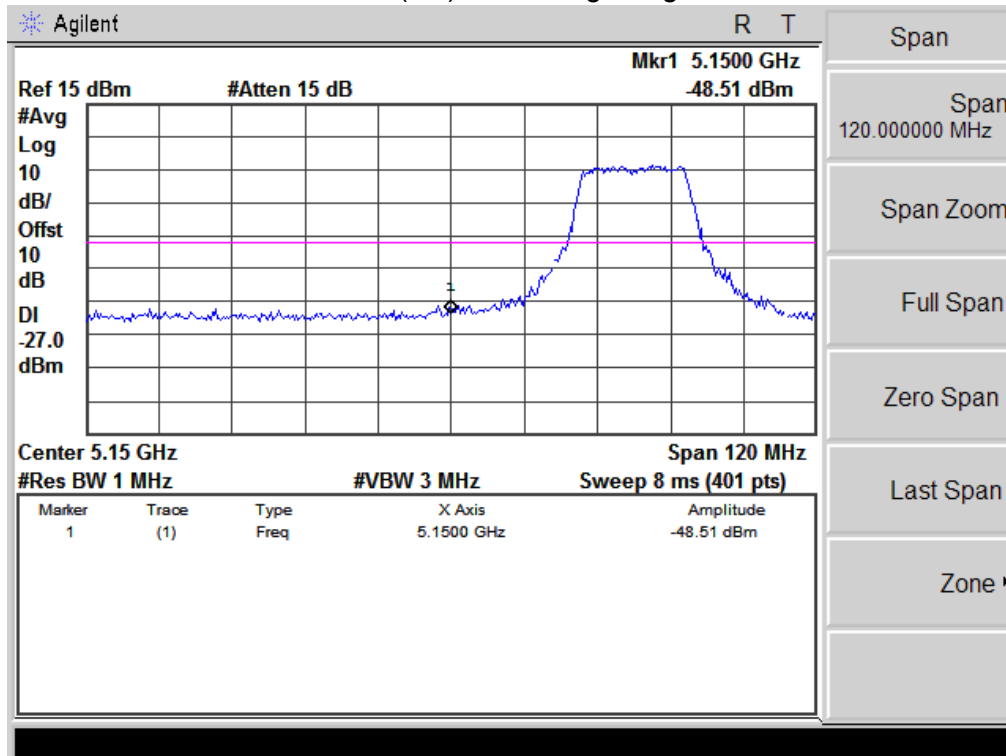

### 802.11 n20(5G): Band Edge, Left Side

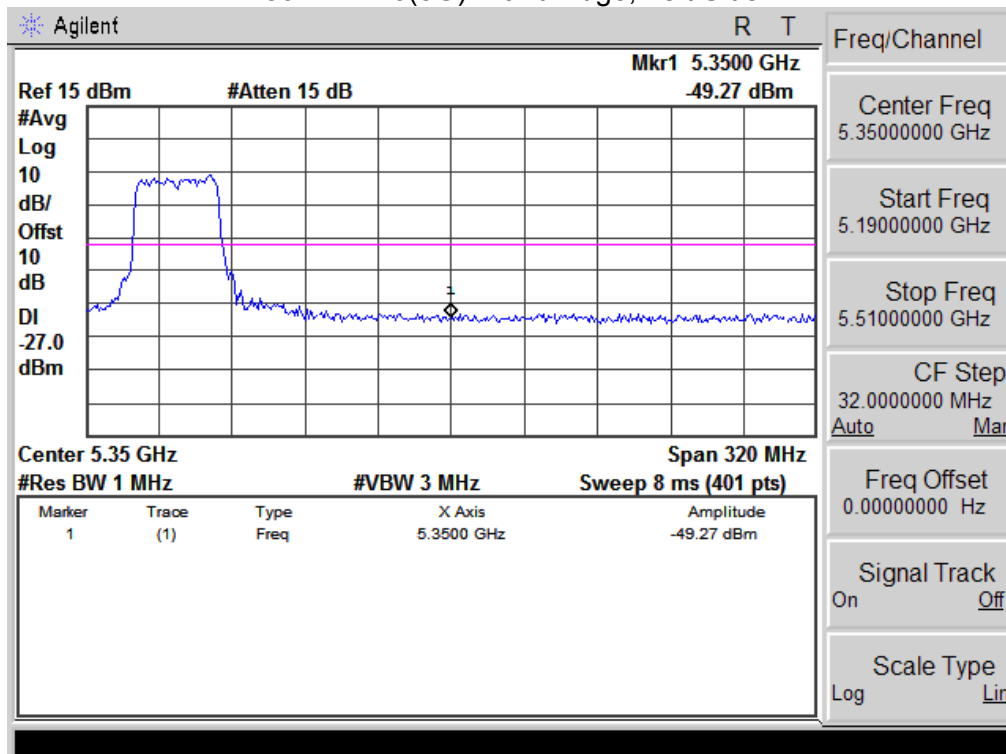

### 802.11 n40(5G): Band Edge, Right Side

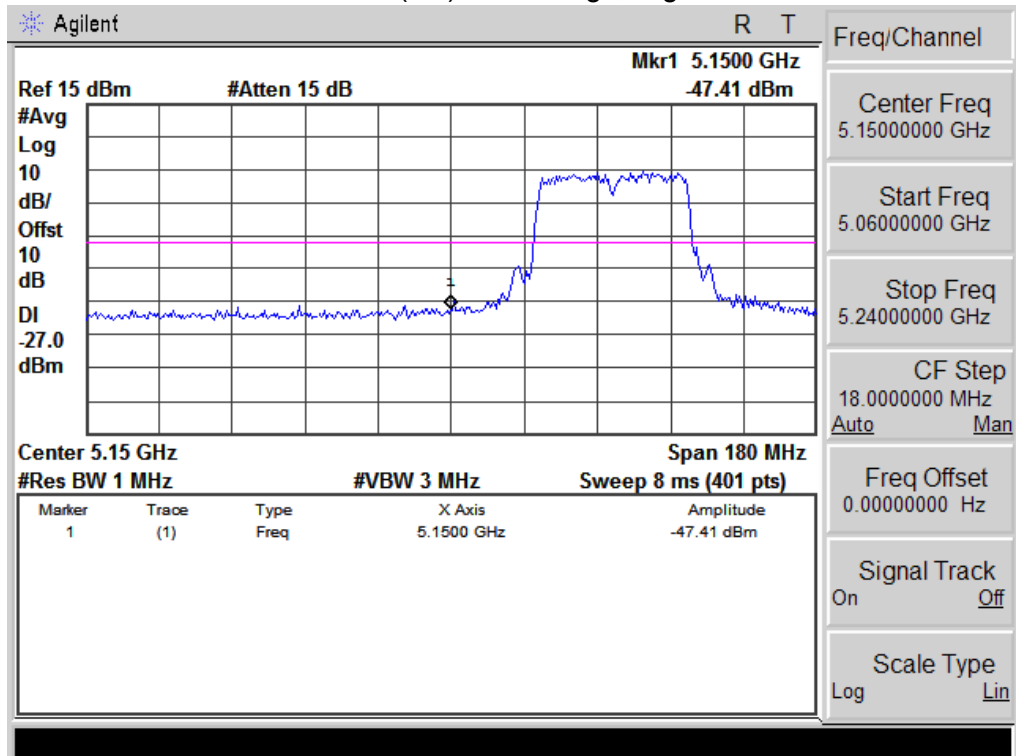

### 802.11 n40(5G): Band Edge, Left Side

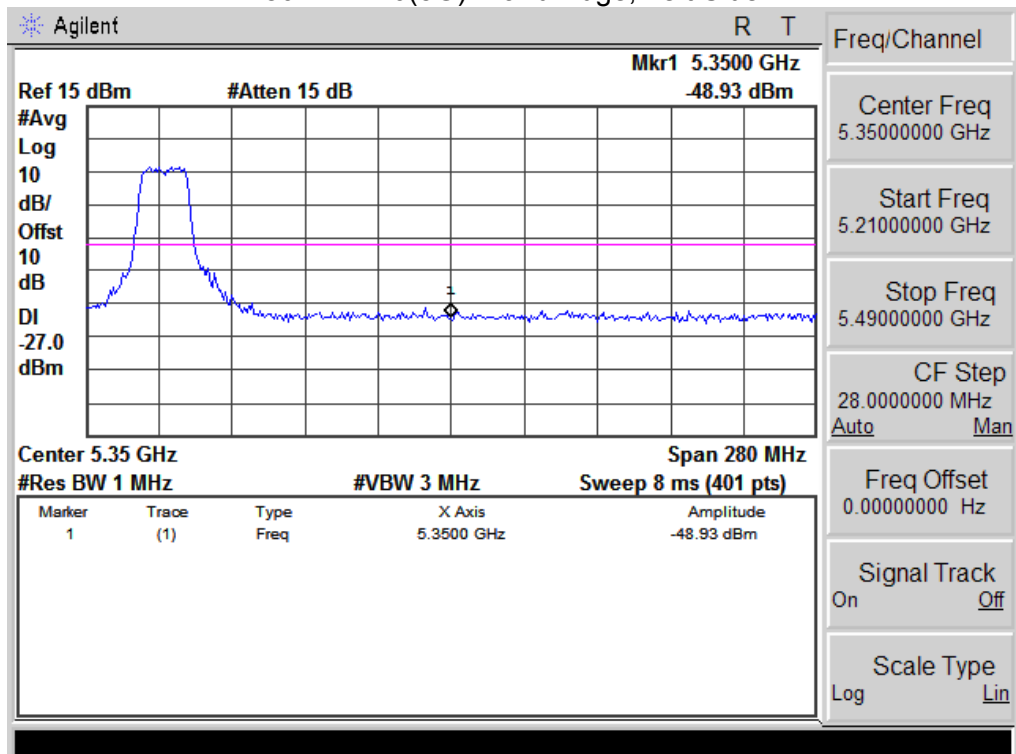

Antenna B

802.11a: Band Edge, Right Side

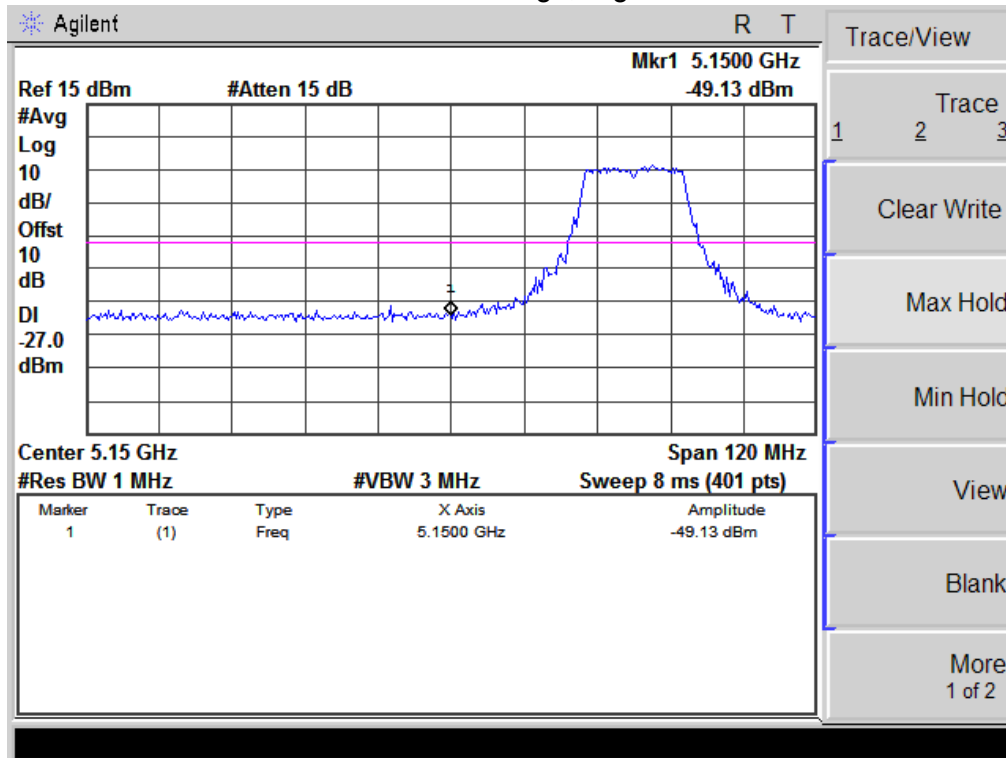

802.11a: Band Edge, Left Side

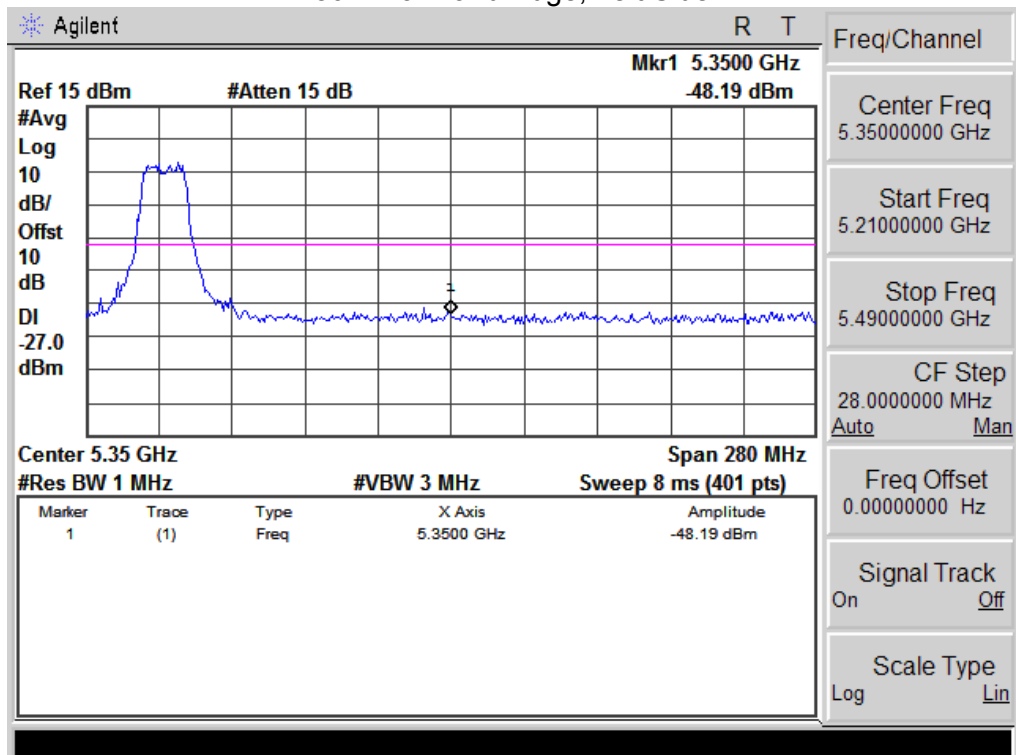

802.11n20(5G): Band Edge, Right Side

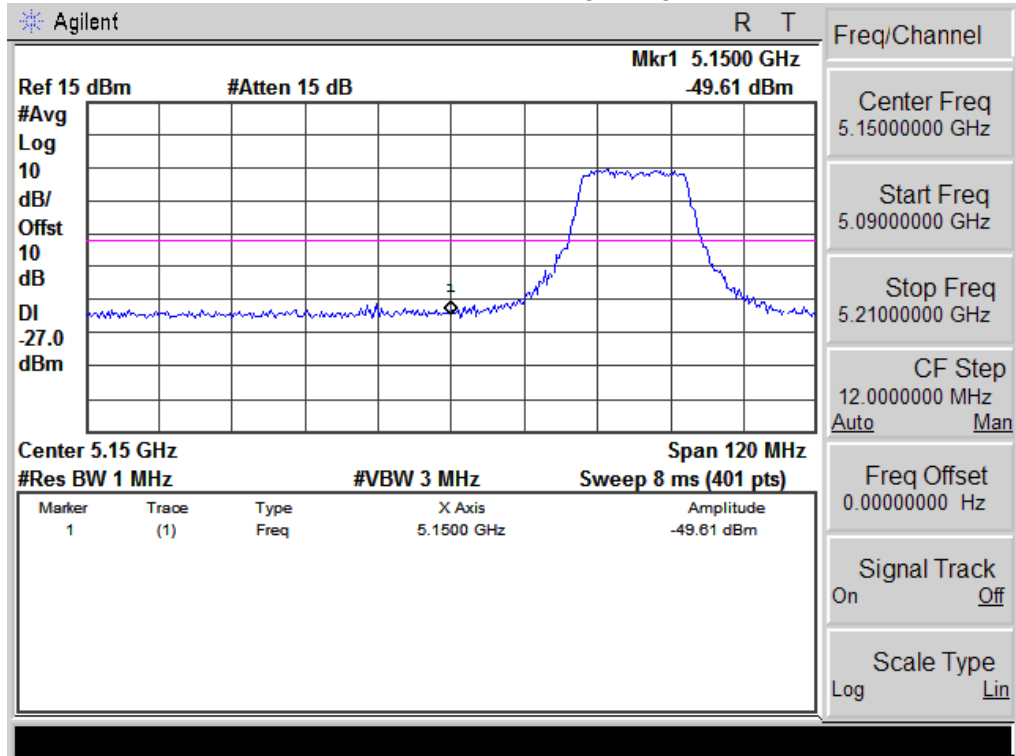

802.11n20(5G): Band Edge, Left Side

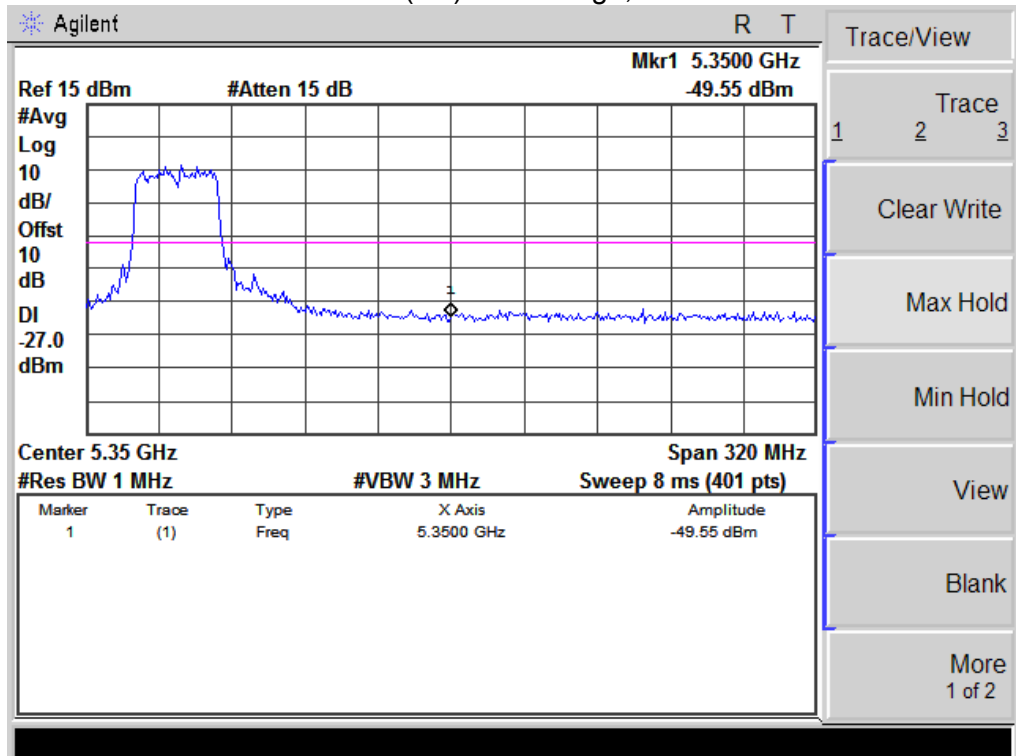

802.11n40(5G): Band Edge, Right Side

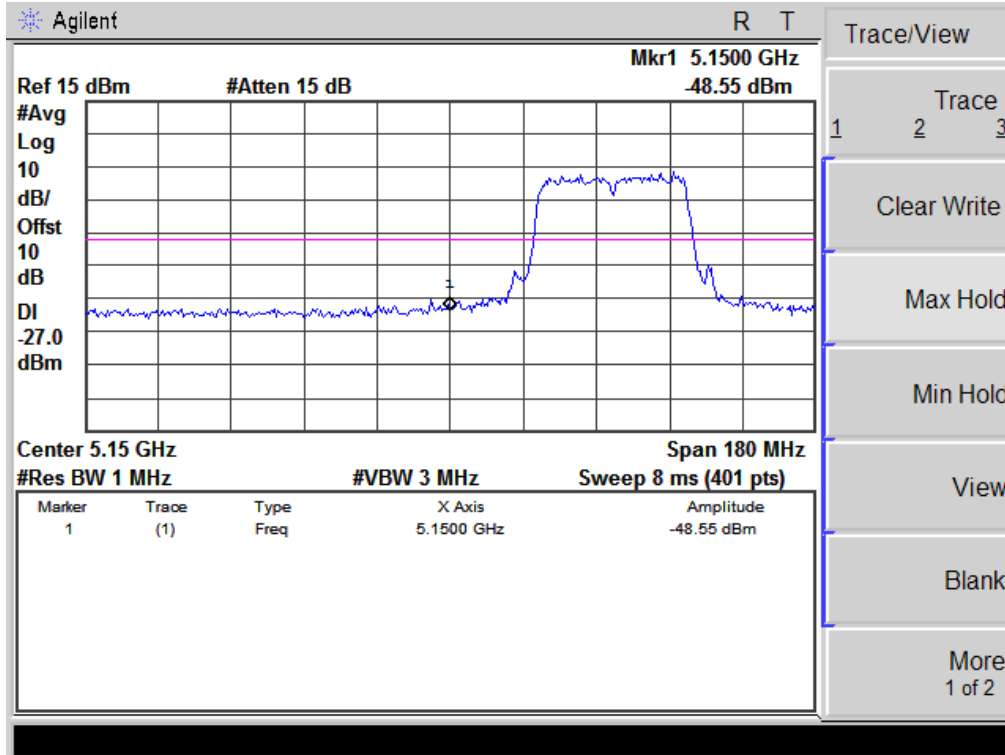

802.11n40(5G): Band Edge, Left Side

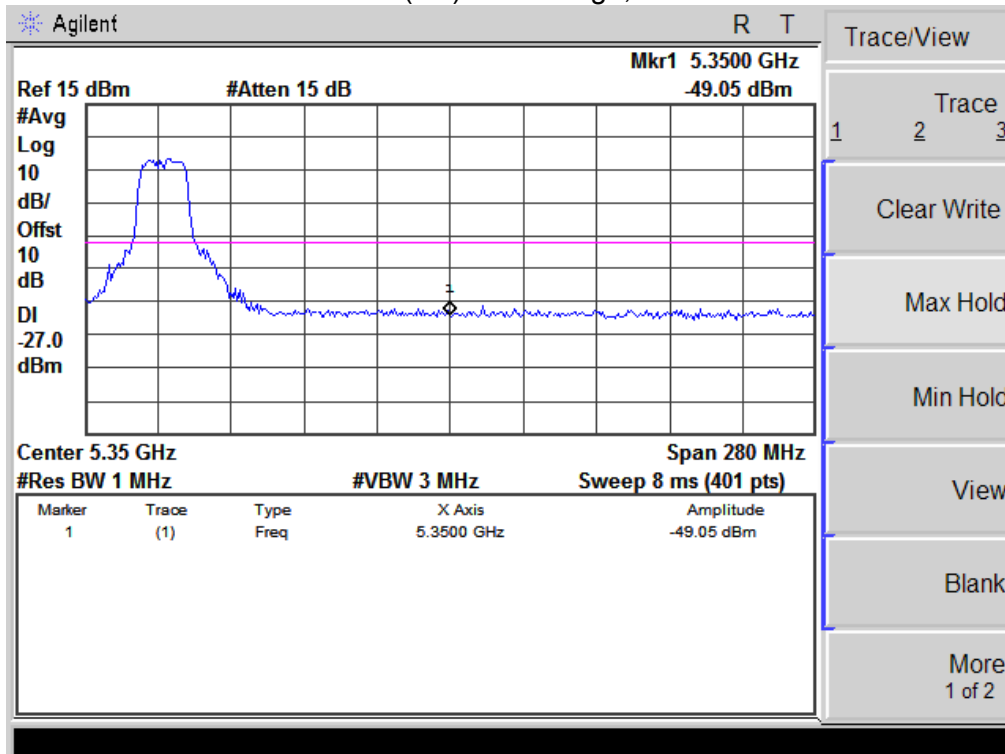

## 8. PEAK EXCURSION RATIO

### 8.1 APPLIED PROCEDURES / LIMIT

According to FCC §15.407(a) (6), the ratio of the peak excursion of the modulation envelope (measured using a peak hold function) to the maximum conducted output power (measured as specified above) shall not exceed 13 dB across any 1 MHz bandwidth or the emission bandwidth whichever is less.

#### 8.1.1 TEST PROCEDURE

The largest difference between the following two traces must be  $\leq 13$  dB for all frequencies across the emission

bandwidth. Submit a plot.

1st Trace:

- Set RBW = 1 MHz, VBW  $\geq 3$  MHz with peak detector and maxhold settings.

2nd Trace:

- create the 2nd trace using the settings described in the setion “FCC §15.407(a)(1)(2) – CONDUCTED TRANSMITTER OUTPUT POWER”.

#### 8.1.2 DEVIATION FROM STANDARD

No deviation.

#### 8.1.3 TEST SETUP

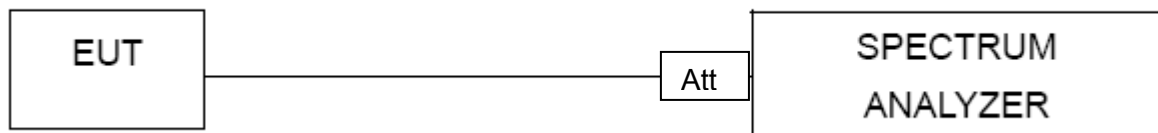

#### 8.1.4 EUT OPERATION CONDITIONS

The EUT tested system was configured as the statements of 2.1 Unless otherwise a special operating condition is specified in the follows during the testing.

**8.1.5 TEST RESULTS**

EUT :	ScreenBeam Mini2 Wireless Display Receiver	Model Name :	SBWD60A
Temperature :	25 °C	Relative Humidity :	56%
Pressure :	1012 hPa	Test Voltage :	DC 5V From adapter AC120V/60Hz

Channel	Frequency (MHz)	TX ANT A PER(dB)	TX ANT B PER(dB)	Limit (dB)
<b>802.11a mode</b>				
Low	5180	-2.561	-2.457	13
Middle	5200	-2.310	-2.608	
High	5240	-2.336	-2.361	
<b>802.11n HT20 mode</b>				
Low	5180	-2.618	-2.633	13
Middle	5200	-2.629	-2.918	
High	5240	-2.622	-2.898	
<b>802.11n HT40 mode</b>				
Low	5190	-1.160	-1.024	13
High	5230	-1.743	-1.085	



Antenna A

802.11a:CH 36

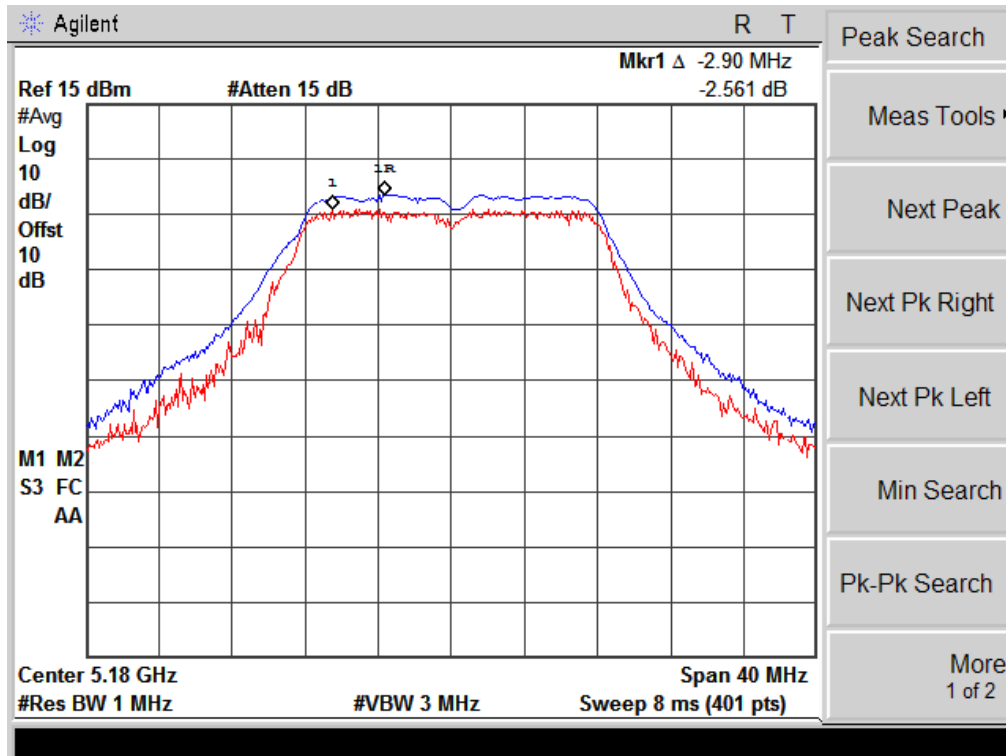

CH 40

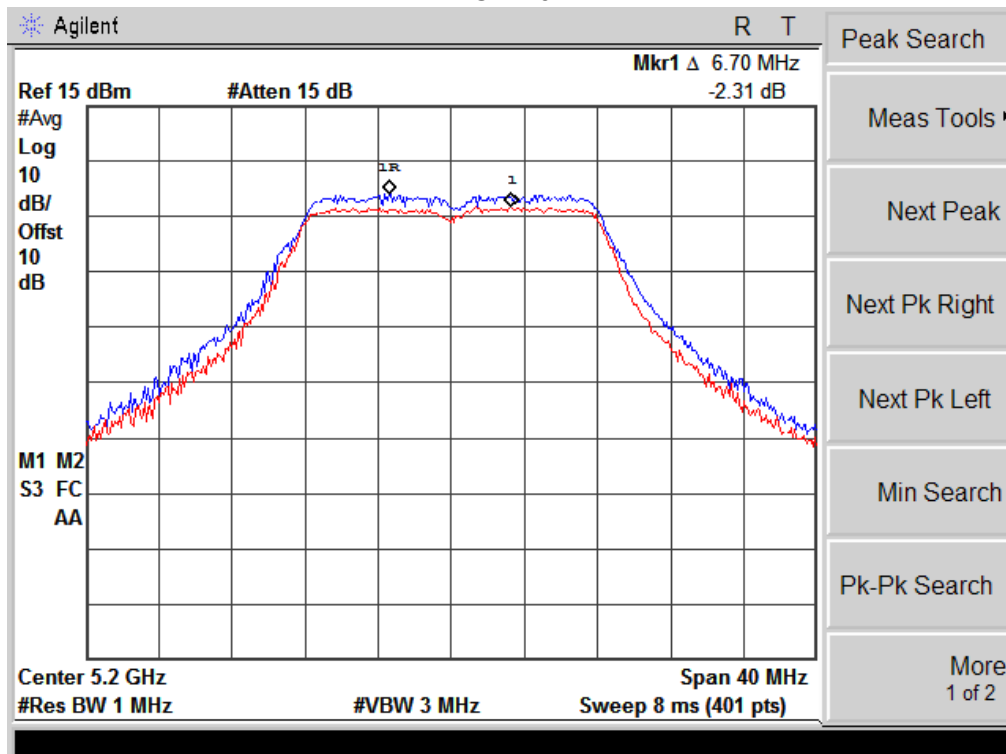

CH 48

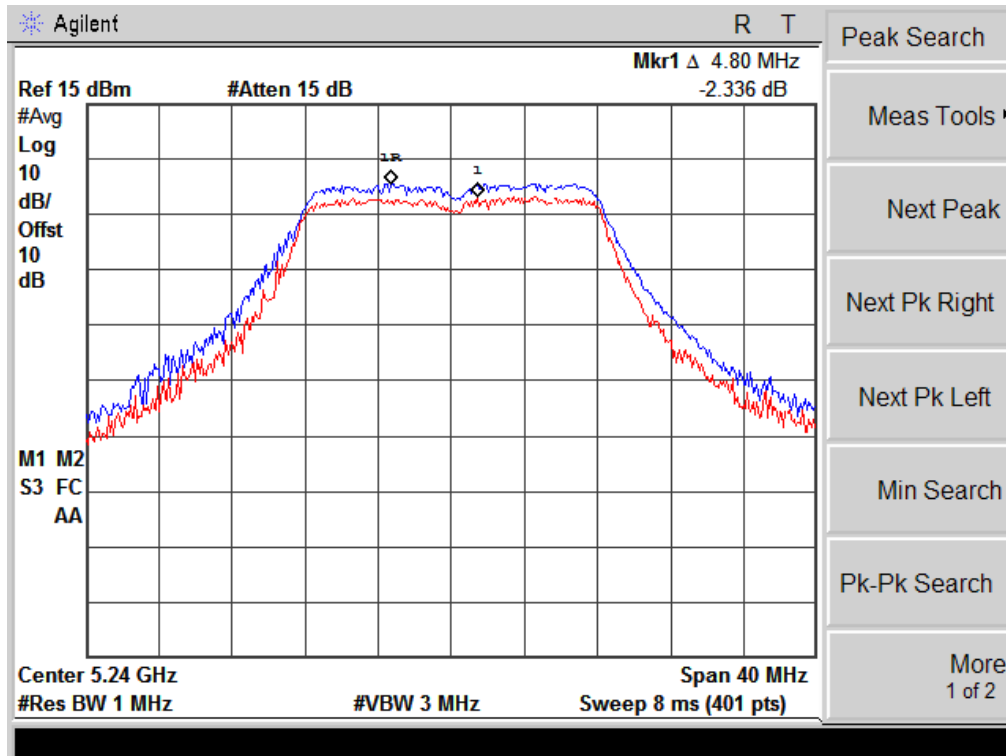

802.11 n20(5G):CH 36

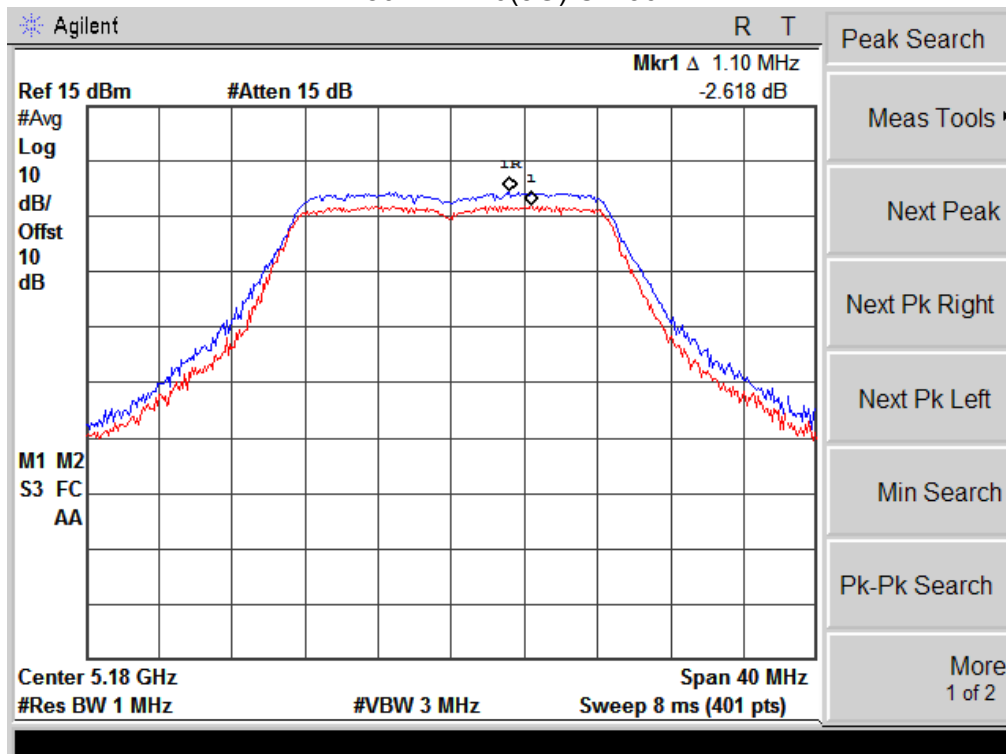

CH 40

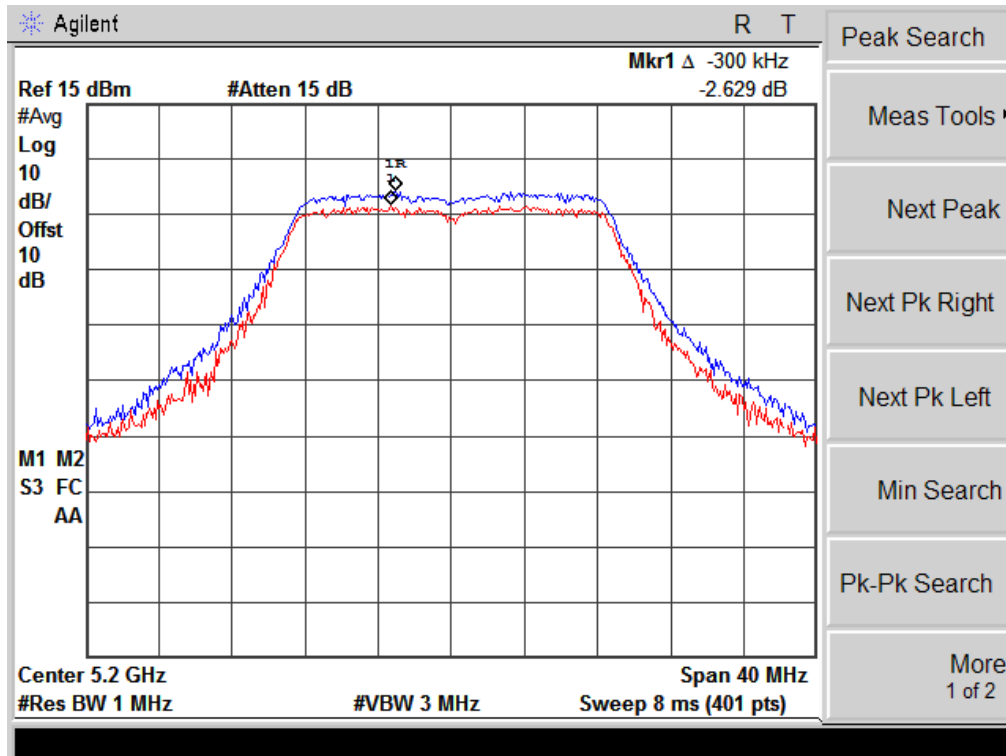

CH 48

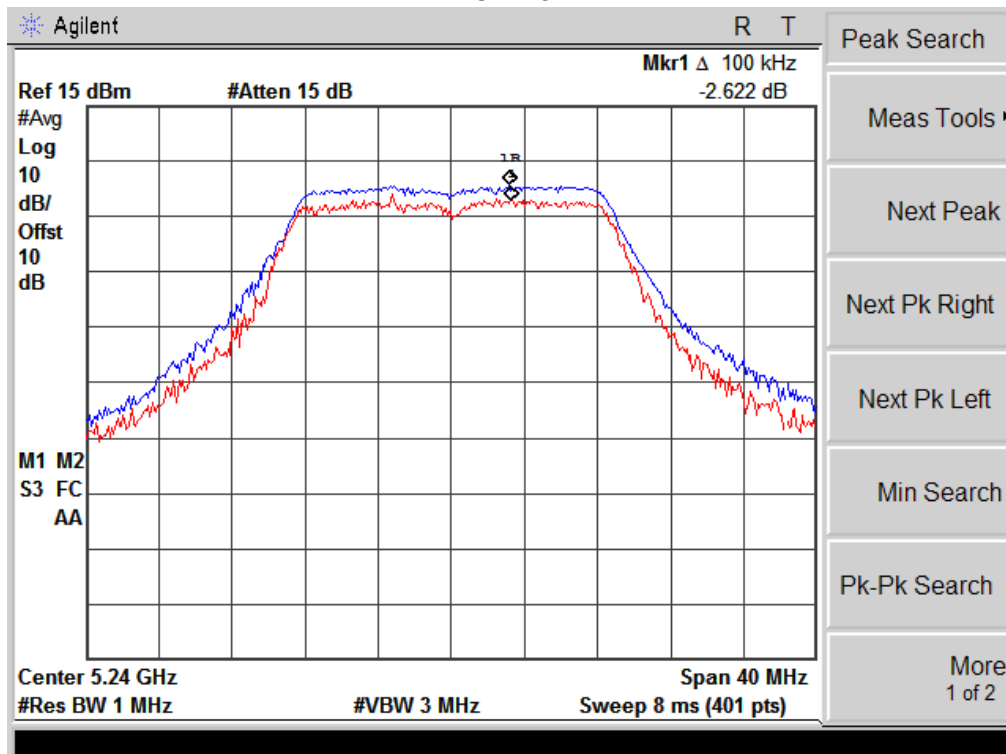

### 802.11 n40(5G):CH 38

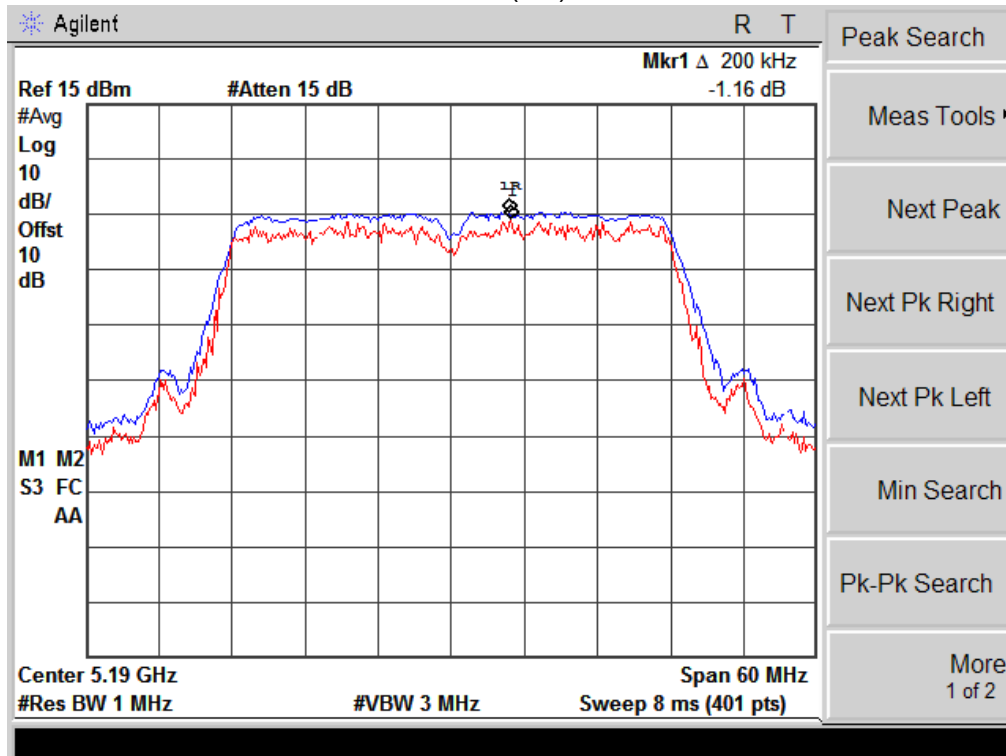

### 802.11 n20(5G):CH 46

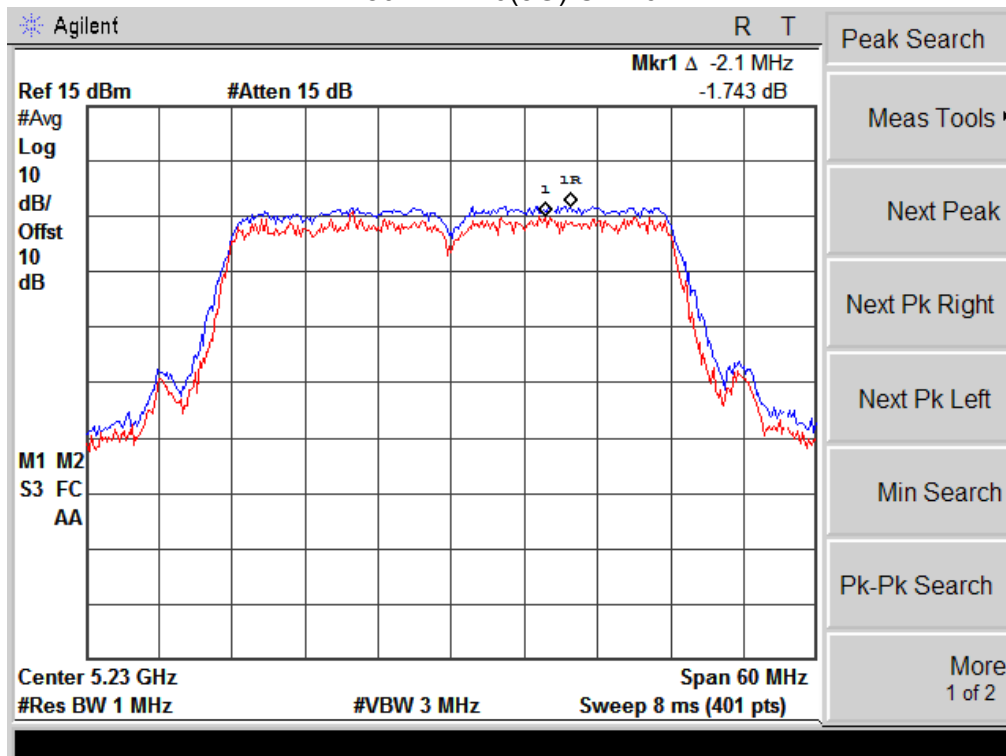

Antenna B

802.11a: CH 36

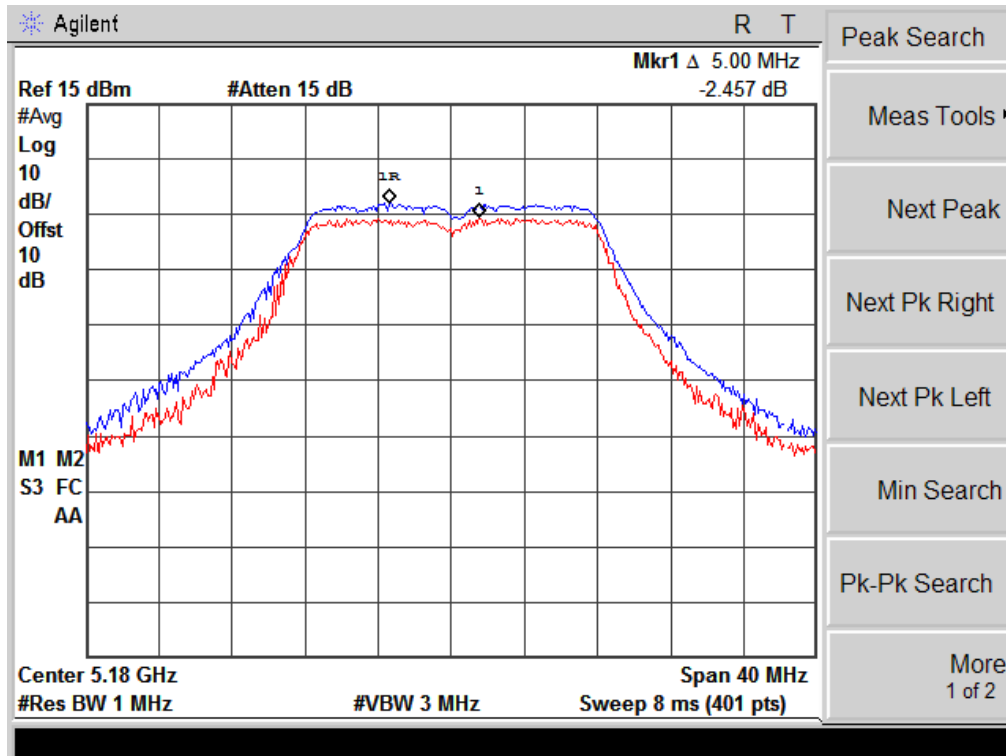

CH 40

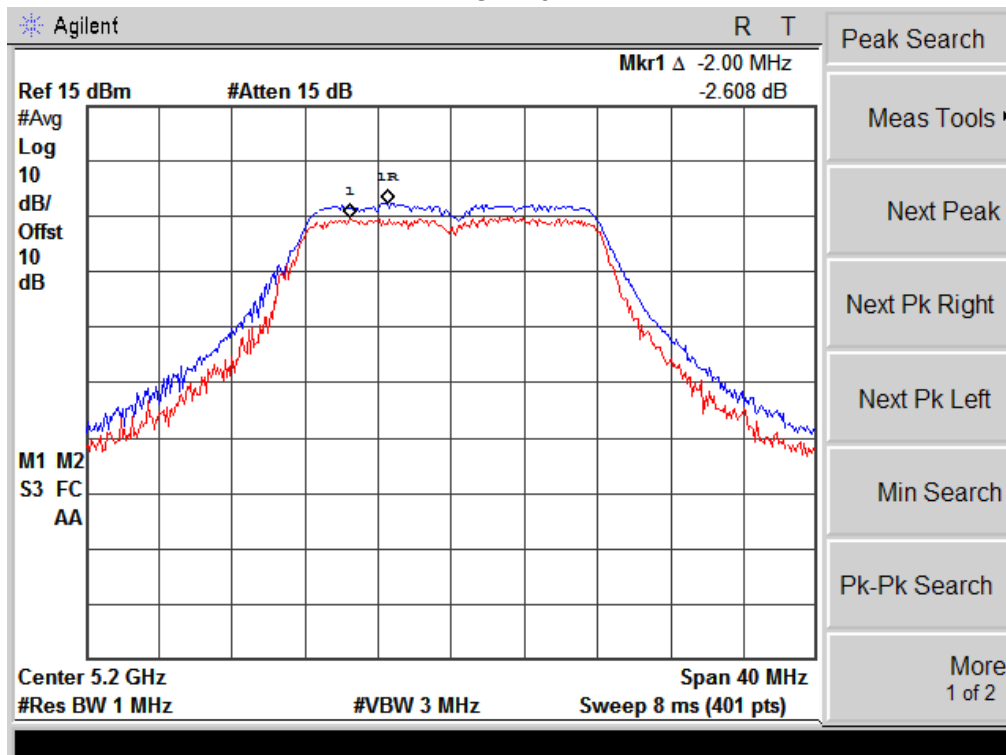

CH 48

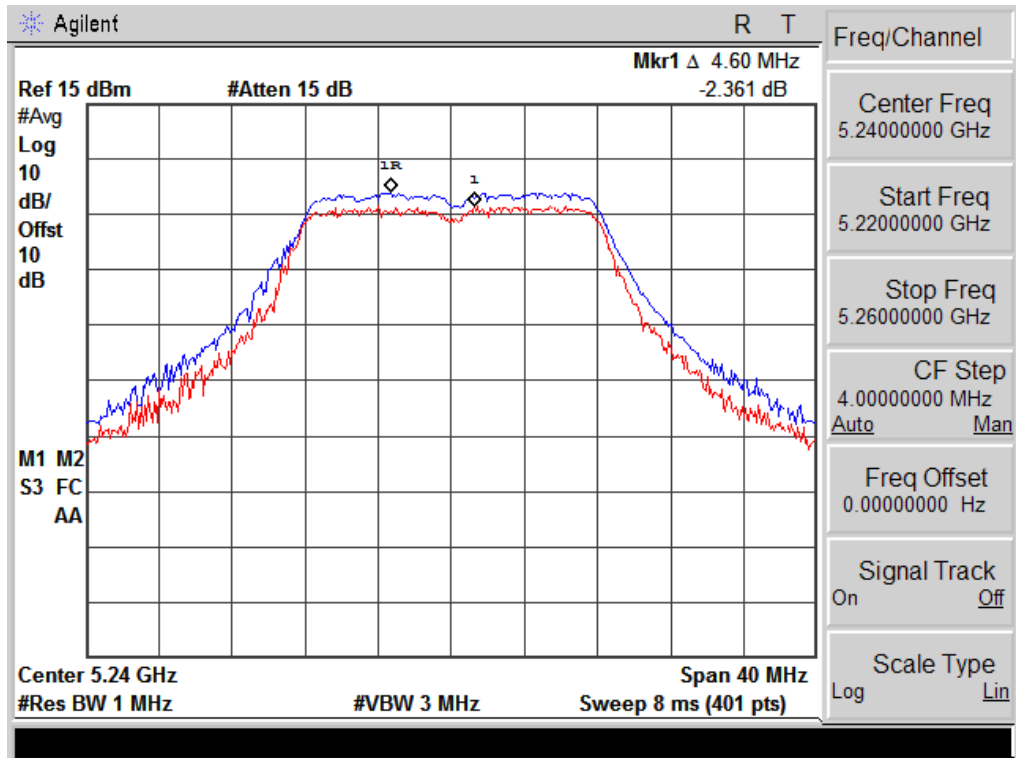

802.11n20(5G): CH 36

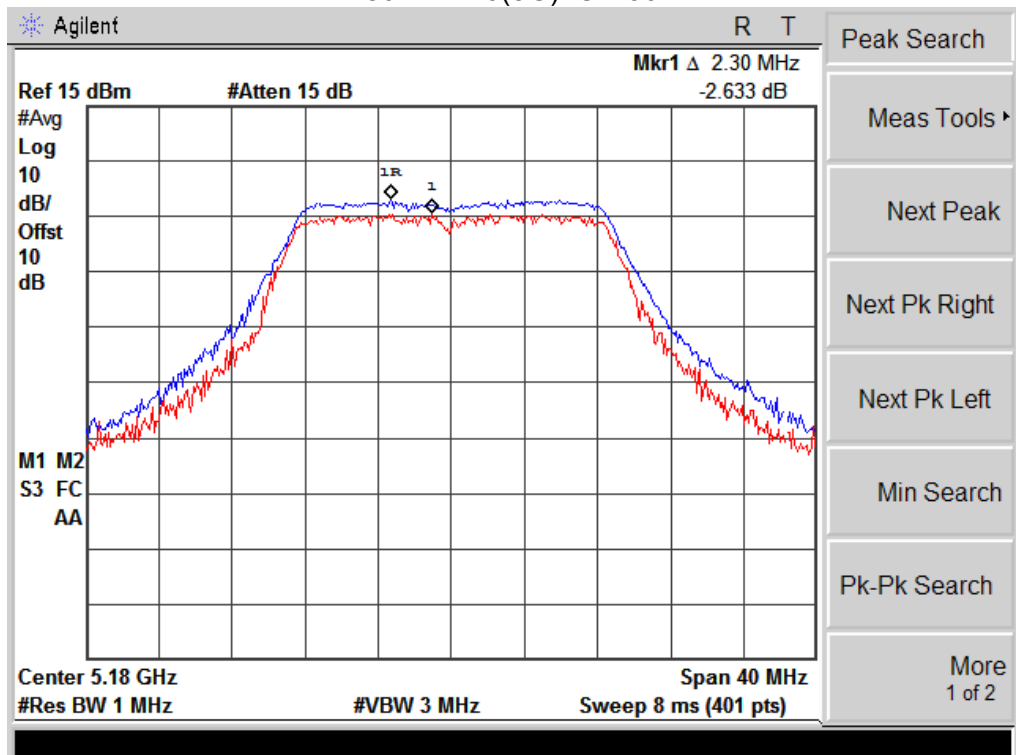

### CH 40

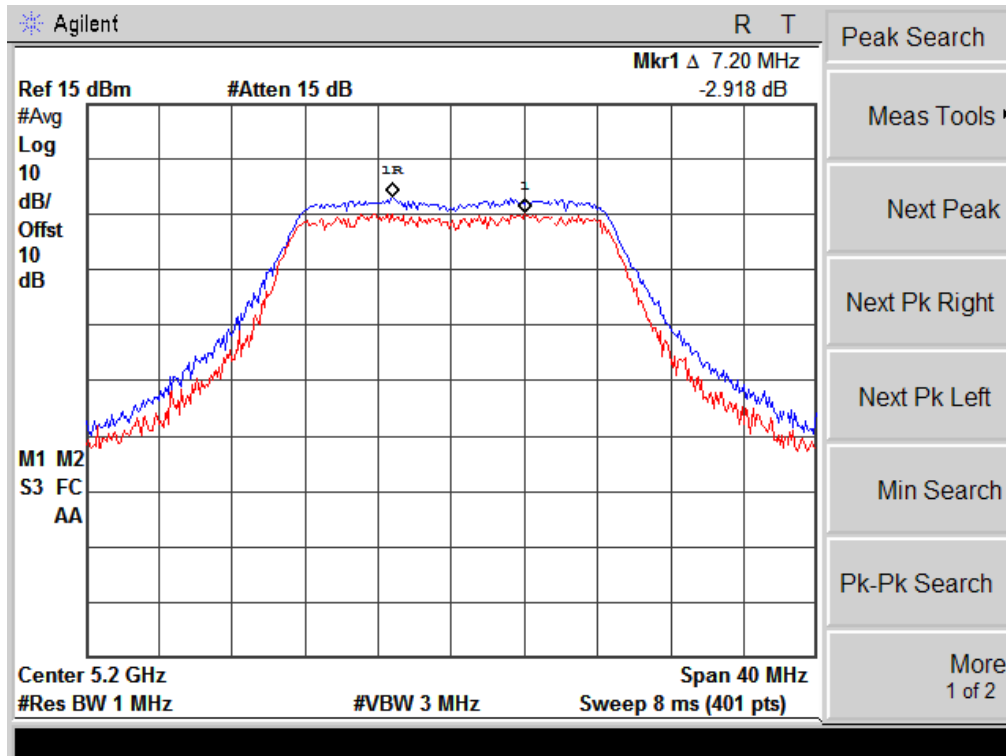

### CH 48

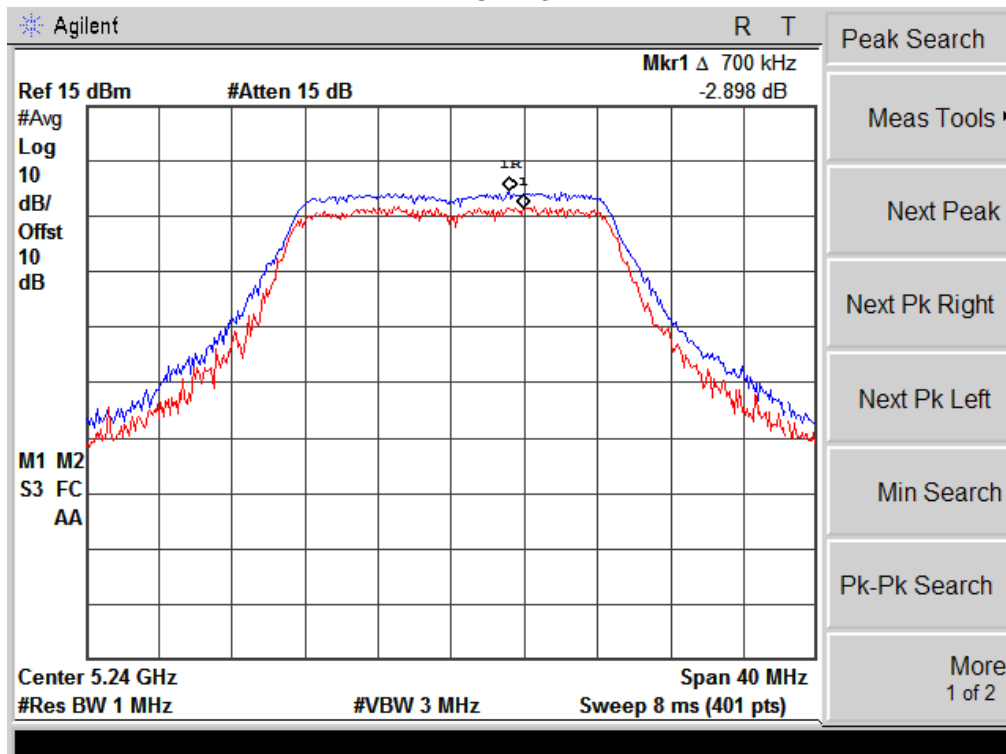

802.11n40(5G): CH 38

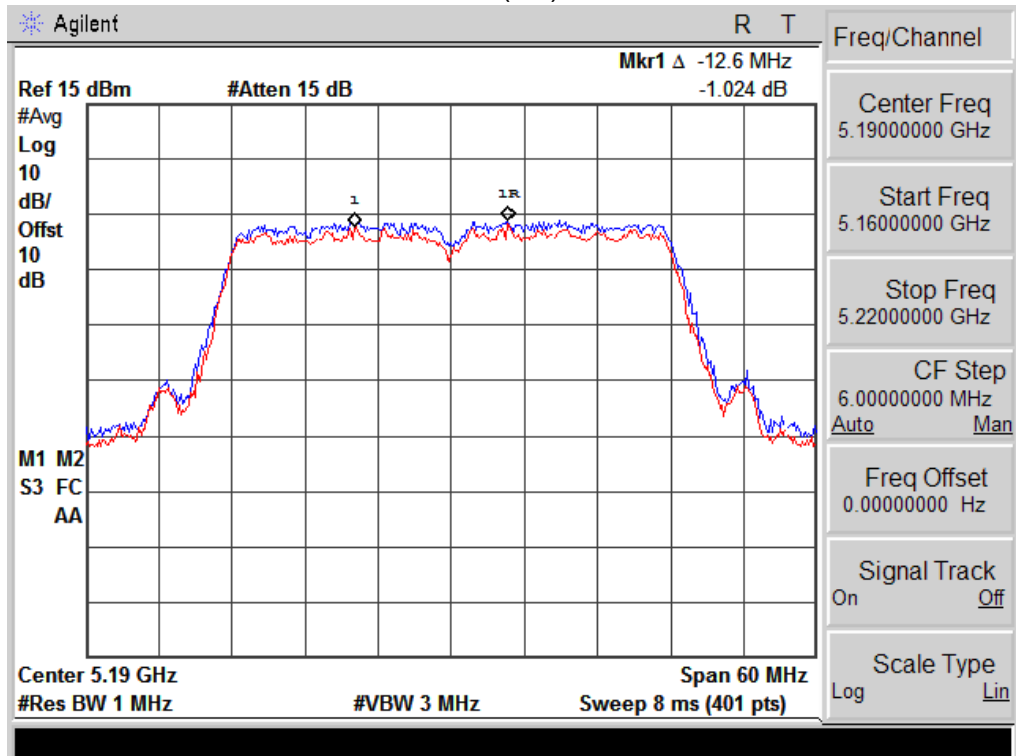

CH 46

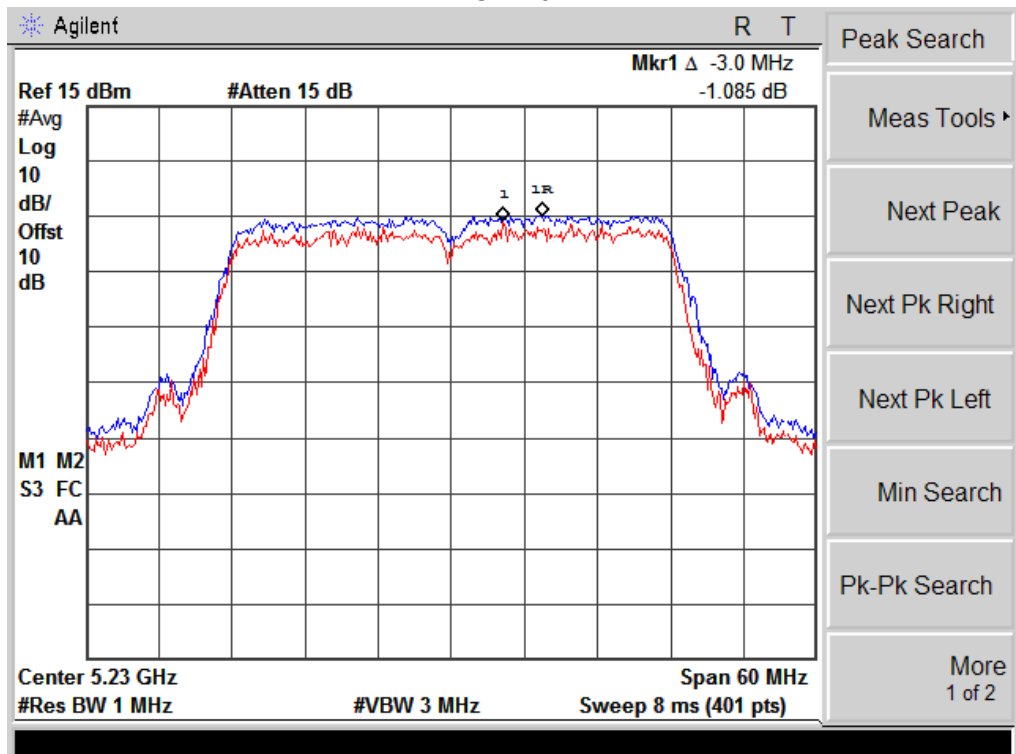



## **9. ANTENNA REQUIREMENT**

### **9.1 STANDARD REQUIREMENT**

15.203 requirement: For intentional device, according to 15.203: an intentional radiator shall be designed to ensure that no antenna other than that furnished by the responsible party shall be used with the device.

### **9.2 EUT ANTENNA**

The EUT antenna is PCB antenna. It comply with the standard requirement.

**10. EUT TEST PHOTO**

**Radiated Measurement Photos**

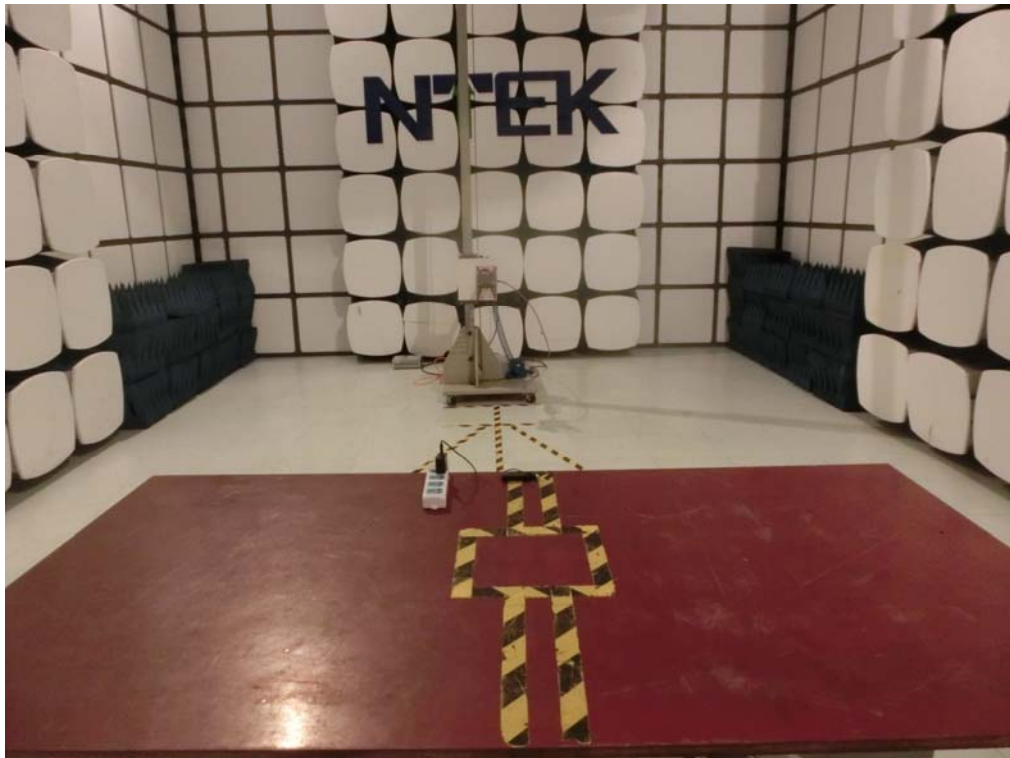
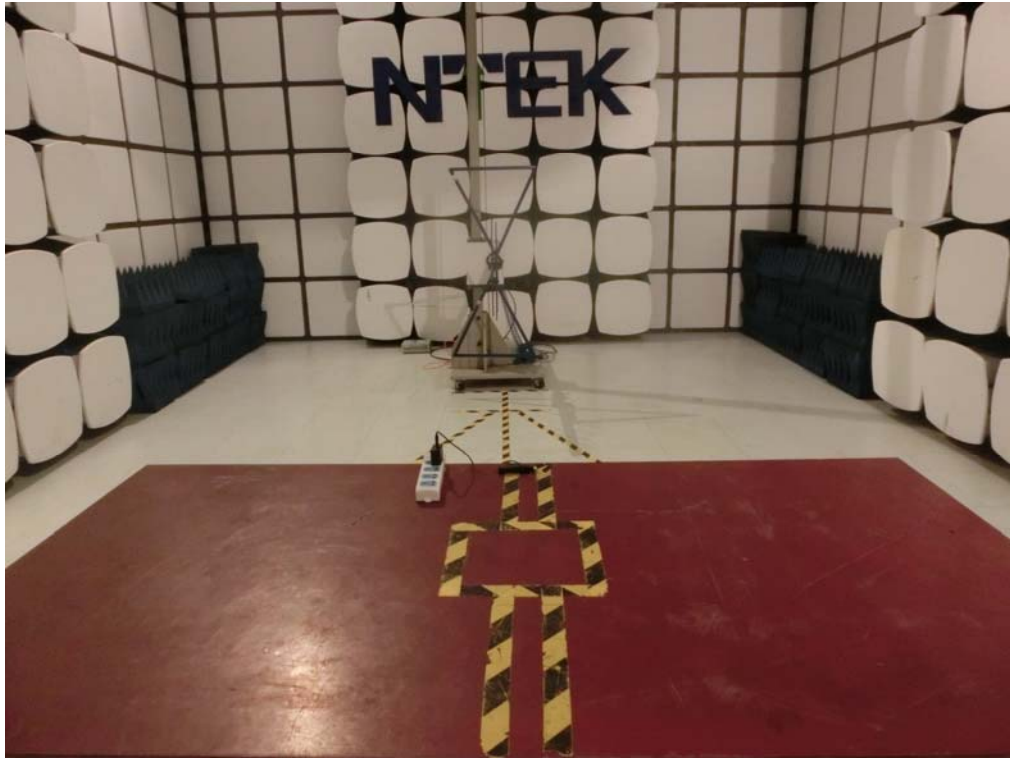

**Conducted Measurement Photos**

