

FCC Test Report

FCC ID:LNQSBWD50A

Product : ScreenBeam Mini Wireless Display Receiver

Trade Name : Actiontec

Model Name : SBWD50A

Serial Model : N/A

Report No. : NTEK-2014NT0210052F2

Prepared for

Actiontec Electronics, Inc.

760 North Mary Ave., Sunnyvale, California 94085 United States

Prepared by

Shenzhen NTEK Testing Technology Co., Ltd.

1/F, Building E, Fenda Science Park, Sanwei Community, Xixiang Street,
Bao'an District, Shenzhen P.R. China

Tel.: +86-0755-61156588 Fax.: +86-0755-61156599

Website: www.ntek.org.cn

TEST RESULT CERTIFICATION

Applicant's name : Actiontec Electronics, Inc.
Address : 760 North Mary Ave., Sunnyvale, California 94085 United States
Manufacturer's Name : Actiontec Electronics, Inc.
Address : 760 North Mary Ave., Sunnyvale, California 94085 United States

Product description

Product name : ScreenBeam Mini Wireless Display Receiver
Model and/or type reference : SBWD50A
Serial Model : N/A
FCC Part15B:2013

Standards : ANSI C63.4:2009
ICES-003 Issue 5 August 2012

This device described above has been tested by NTEK, and the test results show that the equipment under test (EUT) is in compliance with Part 15 of FCC Rules. And it is applicable only to the tested sample identified in the report.

This report shall not be reproduced except in full, without the written approval of NTEK, this document may be altered or revised by NTEK, personal only, and shall be noted in the revision of the document.

Date of Test :
Date (s) of performance of tests : 10 Feb. 2014 ~19 Feb. 2014
Date of Issue : 19 Feb. 2014
Test Result : **Pass**

Testing Engineer : 
(Polo Cha)

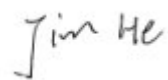
Technical Manager : 
(Jim He)

Authorized Signatory : 
(Bovey Yang)

Table of Contents	Page
1 . TEST SUMMARY	4
1.1 TEST FACILITY	5
1.2 MEASUREMENT UNCERTAINTY	5
2 . GENERAL INFORMATION	6
2.1 GENERAL DESCRIPTION OF EUT	6
2.2 DESCRIPTION OF TEST MODES	7
2.3 DESCRIPTION OF TEST SETUP	8
2.4 DESCRIPTION TEST PERIPHERAL AND EUT PERIPHERAL	9
2.5 MEASUREMENT INSTRUMENTS LIST	10
3 . EMC EMISSION TEST	11
3.1 CONDUCTED EMISSION MEASUREMENT	11
3.1.1 POWER LINE CONDUCTED EMISSION	11
3.1.2 TEST PROCEDURE	12
3.1.3 TEST SETUP	12
3.1.4 EUT OPERATING CONDITIONS	12
3.1.5 TEST RESULTS	13
3.2 RADIATED EMISSION MEASUREMENT	15
3.2.1 LIMITS OF RADIATED EMISSION MEASUREMENT	15
3.2.2 TEST PROCEDURE	15
3.2.3 TEST SETUP	16
3.2.4 EUT OPERATING CONDITIONS	16
3.2.5 TEST RESULTS	17
4 . EUT TEST PHOTO	21

1. TEST SUMMARY

Test procedures according to the technical standards:

EMC Emission				
Standard	Test Item	Limit	Judgment	Remark
FCC Part15B:2013 ANSI C63.4: 2009 ICES-003 Issue 5 August 2012	Conducted Emission	Class B	PASS	
	Radiated Emission	Class B	PASS	

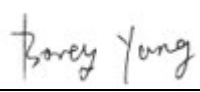
NOTE:

- (1) 'N/A' denotes test is not applicable in this Test Report
- (2) For client's request and manual description, the test will not be executed.

1.1 TEST FACILITY

NTEK Testing Technology Co., Ltd

Add. : 1/F, Building E, Fenda Science Park, Sanwei Community, Xixiang Street, Bao'an District, Shenzhen P.R. China.

FCC Registration Number:238937; IC Registration Number:9270A-1

CNAS Registration Number:L5516

1.2 MEASUREMENT UNCERTAINTY

The reported uncertainty of measurement $y \pm U$, where expanded uncertainty U is based on a standard uncertainty multiplied by a coverage factor of $k=2$, providing a level of confidence of approximately 95 %.

A. Conducted Measurement :

Test Site	Method	Measurement Frequency Range	U , (dB)	NOTE
NTEKC01	ANSI	150 KHz ~ 30MHz	3.2	

B. Radiated Measurement :

Test Site	Method	Measurement Frequency Range	U , (dB)	NOTE
NTEKA01	ANSI	30MHz ~ 1000MHz	4.7	
		1GHz ~6GHz	5.0	

2. GENERAL INFORMATION

2.1 GENERAL DESCRIPTION OF EUT

Equipment	ScreenBeam Mini Wireless Display Receiver	
Model Name	SBWD50A	
Additional Model Number(s)	N/A	
Model Difference	N/A	
Product Description	The EUT is a ScreenBeam Mini Wireless Display Receiver.	
	Operating frequency:	2.4GHz
	Connecting I/O port:	HDMI,USB
	Based on the application, features, or specification exhibited in User's Manual, the EUT is considered as an ITE/Computing Device. More details of EUT technical specification, please refer to the User's Manual.	
Adapter	Mode: SC05100-US Input: 100-240V~, 50/60Hz, 0.4A Output: 5V $\overline{\text{---}}$, 1000mA	
Rating	DC 5V, 1000mA	
Battery	N/A	

2.2 DESCRIPTION OF TEST MODES

To investigate the maximum EMI emission characteristics generates from EUT, the test system was pre-scanning tested base on the consideration of following EUT operation mode or test configuration mode which possible have effect on EMI emission level. Each of these EUT operation mode(s) or test configuration mode(s) mentioned above was evaluated respectively.

Pretest Mode	Description
Mode 1	Working

For Conducted Test	
Final Test Mode	Description
Mode 1	Working

For Radiated Test	
Final Test Mode	Description
Mode 1	Working

2.3 DESCRIPTION OF TEST SETUP

Mode 1:Working

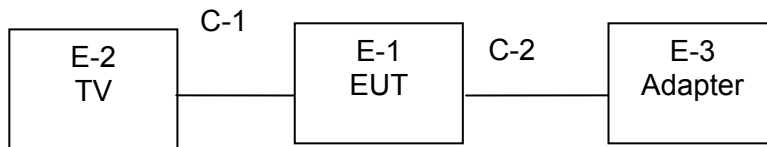

2.4 DESCRIPTION TEST PERIPHERAL AND EUT PERIPHERAL

The EUT has been tested as an independent unit together with other necessary accessories or support units. The following support units or accessories were used to form a representative test configuration during the tests.

Item	Equipment	Brand	Model/Type No.	Series No.	Note
E-1	ScreenBeam Mini Wireless Display Receiver	Actiontec	SBWD50A	N/A	EUT
E-2	TV	SONY	KDL-24EX520	N/A	
E-3	Adapter	N/A	SC05100-US	N/A	

Item	Shielded Type	Ferrite Core	Length	Note
C-1	NO	NO	100cm	
C-2	NO	NO	80cm	

Note:

- (1) The support equipment was authorized by Declaration of Confirmation.
- (2) For detachable type I/O cable should be specified the length in cm in 『Length』 column.
- (3) “YES” means “shielded” “with core”; “NO” means “unshielded” “without core”.

2.5 MEASUREMENT INSTRUMENTS LIST

2.5.1 CONDUCTED TEST SITE

Item	Kind of Equipment	Manufacturer	Type No.	Serial No.	Last calibration	Calibrated until	Calibration period
1	LISN	R&S	ENV216	101313	Jul. 06, 2013	Jul. 05, 2014	1 year
2	LISN	SCHWARZBECK	NNLK 8129	8129245	Dec. 25, 2013	Dec. 24, 2014	1 year
3	Pulse Limiter	SCHWARZBECK	VTSD 9561F	9716	Dec. 25, 2013	Dec. 24, 2014	1 year
4	50Ω Switch	ANRITSU CORP	MP59B	6200983704	Jul. 06, 2013	Jul. 05, 2014	1 year
5	Test Cable	N/A	C01	N/A	Jul. 06, 2013	Jul. 05, 2014	1 year
6	Test Cable	N/A	C02	N/A	Jul. 06, 2013	Jul. 05, 2014	1 year
7	Test Cable	N/A	C03	N/A	Jul. 06, 2013	Jul. 05, 2014	1 year
8	EMI Test Receiver	R&S	ESCI	101160	Jul. 06, 2013	Jul. 05, 2014	1 year
9	Passive Voltage Probe	ESH2-Z3	R&S	100196	Jul. 06, 2013	Jul. 05, 2014	1 year
10	Triple-Loop Antenna	EVERFINE	LIA-2	11020003	Jul. 06, 2013	Jul. 05, 2014	1 year
11	Absorbing Clamp	R&S	MDS-21	100423	Jul. 08, 2013	Jul. 07, 2014	1 year

2.5.2 RADIATED TEST SITE

Item	Kind of Equipment	Manufacturer	Type No.	Serial No.	Last calibration	Calibrated until	Calibration period
1	Bilog Antenna	TESEQ	CBL6111D	31216	Jul. 06, 2013	Jul. 05, 2014	1 year
2	Test Cable	N/A	R-01	N/A	Dec. 25, 2013	Dec. 24, 2014	1 year
3	Test Cable	N/A	R-02	N/A	Dec. 25, 2013	Dec. 24, 2014	1 year
4	EMI Test Receiver	R&S	ESCI-7	101318	Jul. 06, 2013	Jul. 05, 2014	1 year
5	Antenna Mast	EM	SC100_1	N/A	N/A	N/A	N/A
6	Turn Table	EM	SC100	060531	N/A	N/A	N/A
7	50Ω Switch	Anritsu Corp	MP59B	6200983705	Jul. 06, 2013	Jul. 05, 2014	1 year
8	Spectrum Analyzer	Aglient	E4407B	MY45108040	Jul. 06, 2013	Jul. 05, 2014	1 year
9	Horn Antenna	EM	EM-AH-10180	2011071402	Jul. 06, 2013	Jul. 05, 2014	1 year
10	Amplifier	EM	EM-30180	060538	Jul. 06, 2013	Jul. 05, 2014	1 year

3. EMC EMISSION TEST

3.1 CONDUCTED EMISSION MEASUREMENT

3.1.1 POWER LINE CONDUCTED EMISSION (Frequency Range 150KHz-30MHz)

FREQUENCY (MHz)	Class A (dBuV)		Class B (dBuV)	
	Quasi-peak	Average	Quasi-peak	Average
0.15 -0.5	79.00	66.00	66 - 56 *	56 - 46 *
0.50 -5.0	73.00	60.00	56.00	46.00
5.0 -30.0	73.00	60.00	60.00	50.00

Note:

- (1) The tighter limit applies at the band edges.
- (2) The limit of " * " marked band means the limitation decreases linearly with the logarithm of the frequency in the range.

The following table is the setting of the receiver

Receiver Parameters	Setting
Attenuation	10 dB
Start Frequency	0.15 MHz
Stop Frequency	30 MHz
IF Bandwidth	9 kHz

3.1.2 TEST PROCEDURE

- a. The EUT was placed 0.8 meters from the horizontal ground plane with EUT being connected to the power mains through a line impedance stabilization network (LISN). All other support equipments powered from additional LISN(s). The LISN provide 50 Ohm/ 50uH of coupling impedance for the measuring instrument.
- b. Interconnecting cables that hang closer than 40 cm to the ground plane shall be folded back and forth in the center forming a bundle 30 to 40 cm long.
- c. I/O cables that are not connected to a peripheral shall be bundled in the center. The end of the cable may be terminated, if required, using the correct terminating impedance. The overall length shall not exceed 1 m.
- d. LISN at least 80 cm from nearest part of EUT chassis.
- e. For the actual test configuration, please refer to the related Item –EUT Test Photos.

3.1.3 TEST SETUP

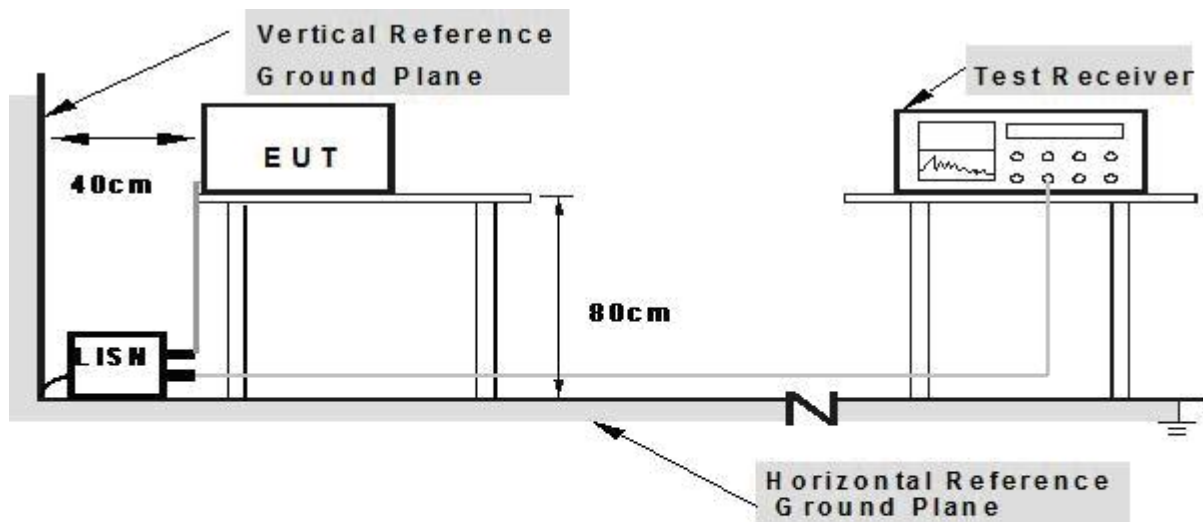

- Note: 1. Support units were connected to second LISN.**
- 2. Both of LISNs (AMN) are 80 cm from EUT and at least 80 from other units and other metal planes**

3.1.4 EUT OPERATING CONDITIONS

The EUT tested system was configured as the statements of 2.3 Unless otherwise a special operating condition is specified in the follows during the testing.

3.1.5 TEST RESULTS

EUT :	ScreenBeam Mini Wireless Display Receiver	Model Name. :	SBWD50A
Temperature :	26 °C	Relative Humidity :	54%
Pressure :	1010hPa	Test Date :	2014-02-18
Test Mode :	Working	Phase :	L
Test Voltage :	DC5V From Adapter AC120V/60Hz		

Freq. (MHz)	Reading (dBuV)	Factor (dBuV)	Measurement (dBuV)	Limit (dBuV)	Over (dB)	Detector
0.1499	42.02	9.66	51.68	66.00	-14.32	QP
0.1499	23.32	9.66	32.98	56.00	-23.02	AVG
0.418	36.10	9.52	45.62	57.49	-11.87	QP
0.418	27.50	9.52	37.02	47.49	-10.47	AVG
0.858	25.70	9.55	35.25	56.00	-20.75	QP
0.858	15.45	9.55	25.00	46.00	-21.00	AVG
1.19	25.98	9.55	35.53	56.00	-20.47	QP
1.19	17.11	9.55	26.66	46.00	-19.34	AVG
5.3459	33.26	9.61	42.87	60.00	-17.13	QP
5.3459	20.46	9.61	30.07	50.00	-19.93	AVG
19.2979	27.78	10.13	37.91	60.00	-22.09	QP
19.2979	15.56	10.13	25.69	50.00	-24.31	AVG

Remark:

Factor = Insertion Loss + Cable Loss.

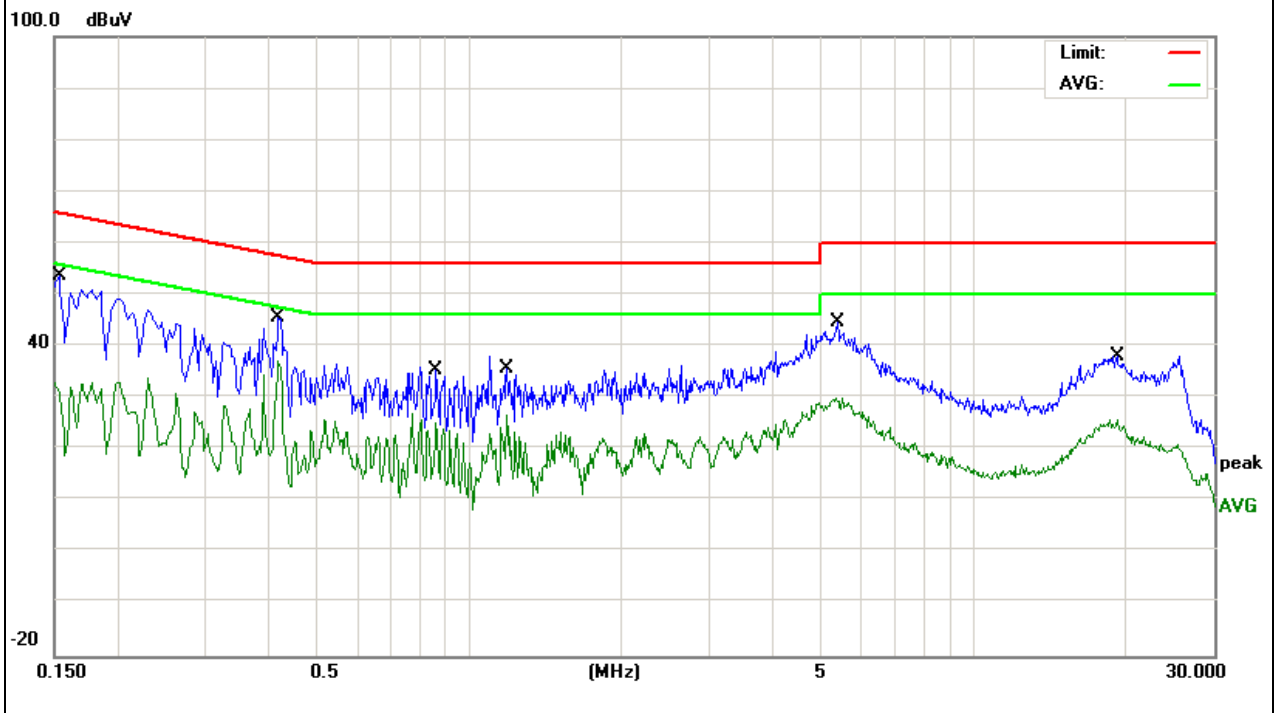

EUT :	ScreenBeam Mini Wireless Display Receiver	Model Name. :	SBWD50A
Temperature :	26 °C	Relative Humidity :	54%
Pressure :	1010hPa	Test Date :	2014-02-18
Test Mode :	Working	Phase :	N
Test Voltage :	DC5V From Adapter AC120V/60Hz		

Freq. (MHz)	Reading (dBuV)	Factor (dBuV)	Measurement (dBuV)	Limit (dBuV)	Over (dB)	Detector
0.1700	41.66	9.59	51.25	64.96	-13.71	QP
0.1700	29.16	9.59	38.75	54.96	-16.21	AVG
0.2020	39.76	9.50	49.26	63.52	-14.26	QP
0.2020	28.05	9.50	37.55	53.52	-15.97	AVG
0.4180	35.51	9.52	45.03	57.49	-12.46	QP
0.4180	26.72	9.52	36.24	47.49	-11.25	AVG
0.7940	25.20	9.54	34.74	56.00	-21.26	QP
0.7940	16.90	9.54	26.44	46.00	-19.56	AVG
1.1660	23.47	9.55	33.02	56.00	-22.98	QP
1.1660	15.89	9.55	25.44	46.00	-20.56	AVG
5.3419	33.56	9.61	43.17	60.00	-16.83	QP
5.3419	22.00	9.61	31.61	50.00	-18.39	AVG

Remark:

Factor = Insertion Loss + Cable Loss.

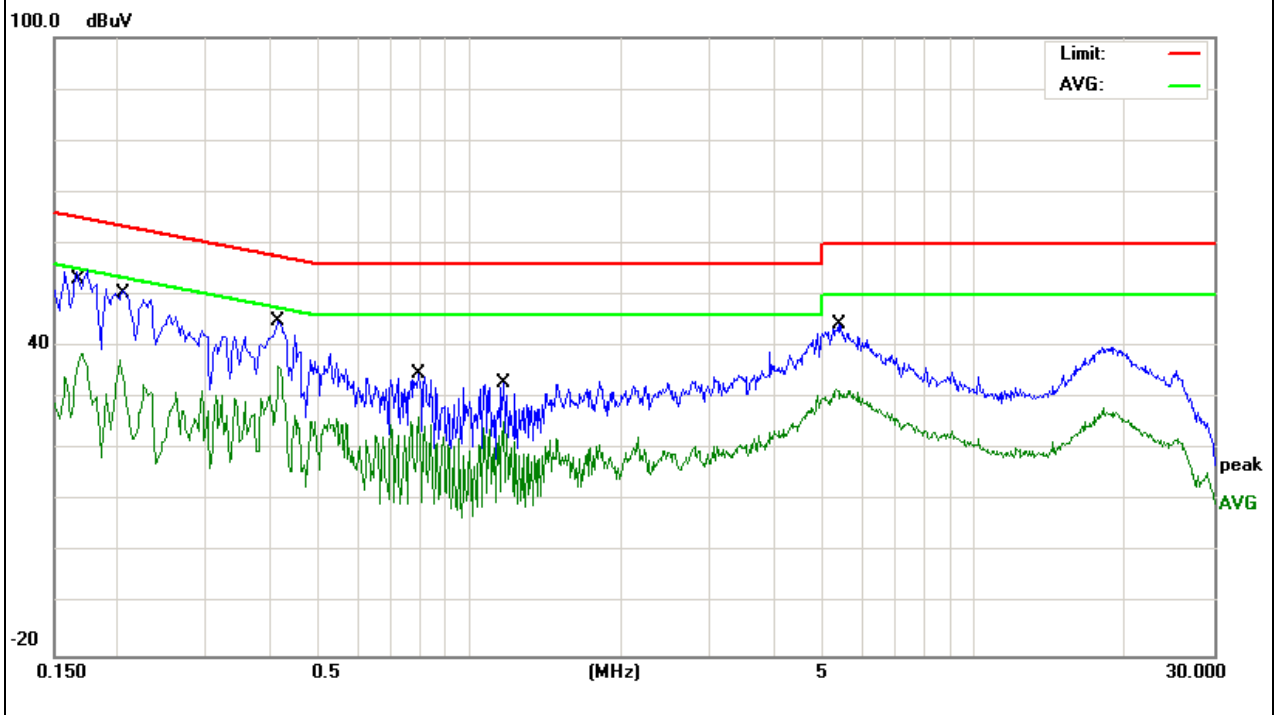

3.2 RADIATED EMISSION MEASUREMENT

3.2.1 LIMITS OF RADIATED EMISSION MEASUREMENT

FREQUENCY (MHz)	Class A (at 10m)	Class B (at 3m)
	dBuV/m	dBuV/m
30 ~ 88	39.0	40.0
88 ~ 216	43.5	43.5
216 ~ 960	46.5	46.0
Above 960	49.5	54.0

Notes:

- (1) The limit for radiated test was performed according to as following:
FCC PART 15B /ICES-003.
- (2) The tighter limit applies at the band edges.
- (3) Emission level (dBuV/m)=20log Emission level (uV/m).

3.2.2 TEST PROCEDURE

- a. The measuring distance of at 10 m shall be used for measurements at frequency up to 1GHz. For frequencies above 1GHz, any suitable measuring distance may be used.
- b. The EUT was placed on the top of a rotating table 0.8 meters above the ground at a 10 meter open area test site. The table was rotated 360 degrees to determine the position of the highest radiation.
- c. The height of the equipment or of the substitution antenna shall be 0.8 m; the height of the test antenna shall vary between 1 m to 4 m. Both horizontal and vertical polarizations of the antenna are set to make the measurement.
- d. The initial step in collecting conducted emission data is a spectrum analyzer peak detector mode pre-scanning the measurement frequency range. Significant peaks are then marked and then Quasi Peak detector mode re-measured, above 1G Average detector mode will be instead.
- e. If the Peak Mode measured value compliance with and lower than Quasi Peak Mode Limit, the EUT shall be deemed to meet QP(AV) Limits and then no additional QP Mode measurement performed.
- f. For the actual test configuration, please refer to the related Item –EUT Test Photos.

3.2.3 TEST SETUP

(A) Radiated Emission Test Set-Up Frequency Below 1 GHz

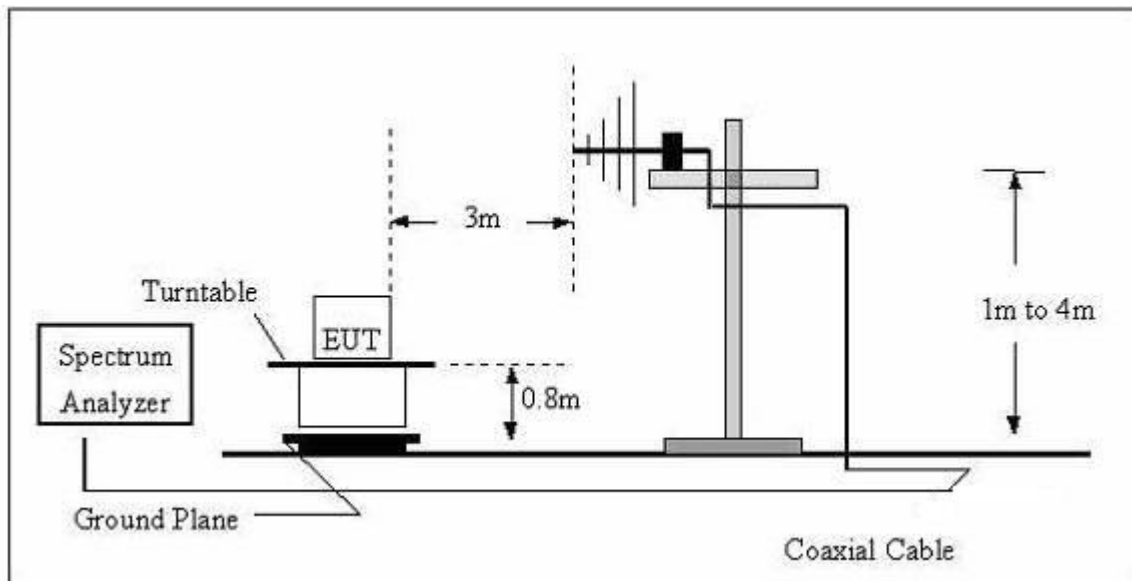

(B) Radiated Emission Test Set-Up Frequency Above 1GHz

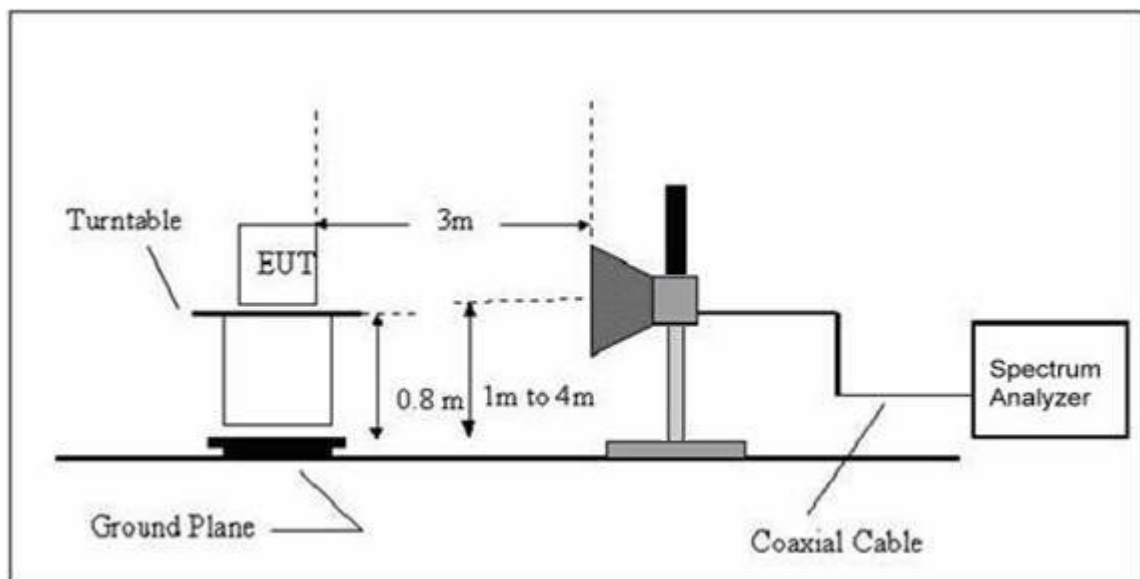

3.2.4 EUT OPERATING CONDITIONS

The EUT tested system was configured as the statements of 2.3 Unless otherwise a special operating condition is specified in the follows during the testing.

3.2.5 TEST RESULTS

EUT :	ScreenBeam Mini Wireless Display Receiver	Model Name :	SBWD50A
Temperature :	24 °C	Relative Humidity :	54%
Pressure :	1010 hPa	Test Date :	2014-02-18
Test Mode :	Working	Polarization :	Horizontal
Test Power :	DC5V From Adapter AC120V/60Hz		

Freq. (MHz)	Reading (dBuV)	Factor (dBuV)	Measurement (dBuV)	Limit (dBuV)	Over (dB)	Detector
175.0368	21.80	10.08	31.88	43.50	-11.62	QP
225.308	25.63	10.73	36.36	46.00	-9.64	QP
475.4991	21.13	19.89	41.02	46.00	-4.98	QP
625.078	16.80	23.60	40.40	46.00	-5.60	QP
776.8778	16.53	26.15	42.68	46.00	-3.32	QP
922.5157	13.00	28.80	41.80	46.00	-4.20	QP

Remark:

Factor = Antenna Factor + Cable Loss.

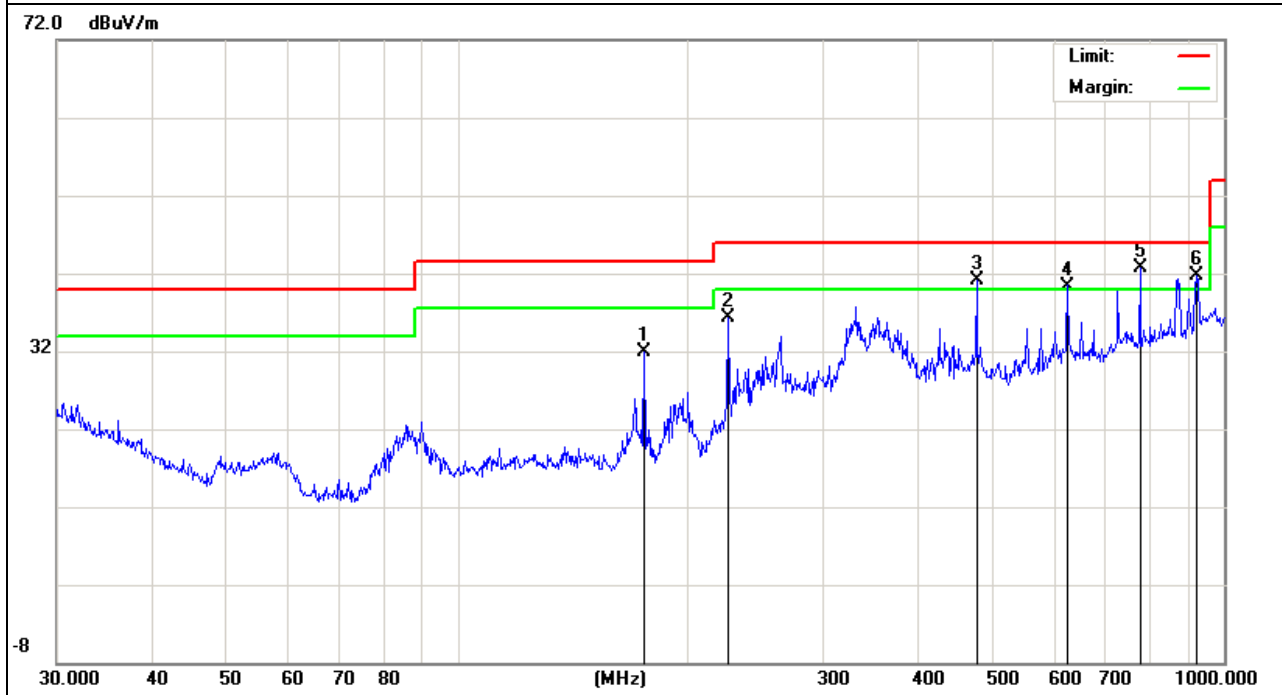

EUT :	ScreenBeam Mini Wireless Display Receiver	Model Name :	SBWD50A
Temperature :	24 °C	Relative Humidity :	54%
Pressure :	1010 hPa	Test Date :	2014-02-18
Test Mode :	Working	Polarization :	Vetical
Test Power :	DC5V From Adapter AC120V/60Hz		

Freq. (MHz)	Reading (dBuV)	Factor (dBuV)	Measurement (dBuV)	Limit (dBuV)	Over (dB)	Detector
175.0368	15.89	10.08	25.97	43.50	-17.53	QP
225.308	25.68	10.73	36.41	46.00	-9.59	QP
475.4991	21.12	19.89	41.01	46.00	-4.99	QP
625.078	13.56	23.60	37.16	46.00	-8.84	QP
776.8778	17.00	26.15	43.15	46.00	-2.85	QP
875.247	14.42	27.32	41.74	46.00	-4.26	QP

Remark:

Factor = Antenna Factor + Cable Loss.

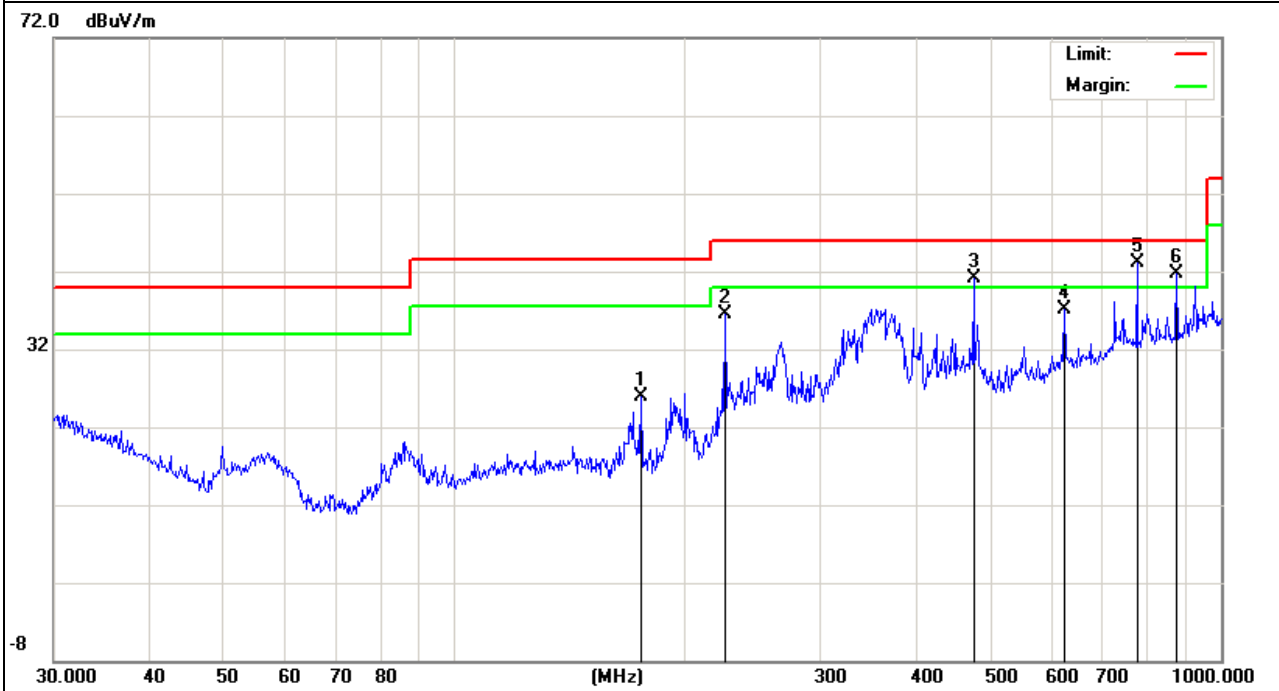

3.2.6 TEST RESULTS(Above 1GHz)

EUT :	ScreenBeam Mini Wireless Display Receiver	Model Name :	SBWD50A
Temperature :	24 °C	Relative Humidity :	54%
Pressure :	1010 hPa	Test Date :	2014-02-18
Test Mode :	Working	Polarization :	Horizontal
Test Power :	DC 5V From AC 120V/60Hz		

Freq. (MHz)	Reading (dBuV)	Factor (dBuV)	Measurement (dBuV)	Limit (dBuV)	Over (dB)	Detector
1187.688	61.75	-18.27	43.48	74.00	-30.52	peak
2095.928	58.60	-11.88	46.72	74.00	-27.28	peak
2453.883	60.84	-12.91	47.93	74.00	-26.07	peak
2791.777	59.40	-11.65	47.75	74.00	-26.25	peak
3924.004	57.60	-6.76	50.84	74.00	-23.16	peak
4821.884	56.40	-3.60	52.80	74.00	-21.20	peak

Remark:

1. When PK value is lower than the Average value limit, average not record.
2. Factor = Antenna Factor + Cable Loss - Amplifier.

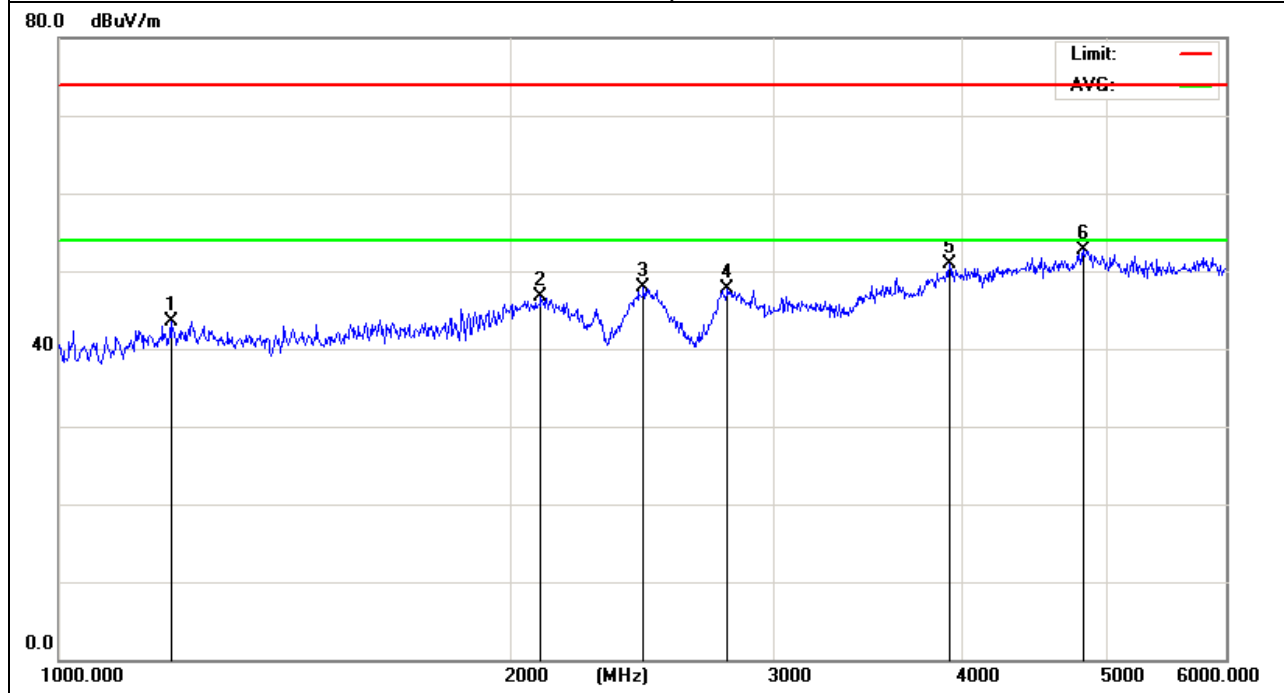

EUT :	ScreenBeam Mini Wireless Display Receiver	Model Name :	SBWD50A
Temperature :	24 °C	Relative Humidity :	54%
Pressure :	1010 hPa	Test Date :	2014-02-18
Test Mode :	Working	Polarization :	Vertical
Test Power :	DC 5V From AC 120V/60Hz		

Freq. (MHz)	Reading (dBuV)	Factor (dBuV)	Measurement (dBuV)	Limit (dBuV)	Over (dB)	Detector
1187.688	64.57	-18.27	46.30	74.00	-27.70	peak
1433.535	63.23	-17.12	46.11	74.00	-27.89	peak
1979.136	65.50	-13.69	51.81	74.00	-22.19	peak
2796.783	55.94	-11.67	44.27	74.00	-29.73	peak
3980.656	53.64	-6.52	47.12	74.00	-26.88	peak
4830.532	56.39	-3.57	52.82	74.00	-21.18	peak

Remark:

1. When PK value is lower than the Average value limit, average not record.
2. Factor = Antenna Factor + Cable Loss - Amplifier.

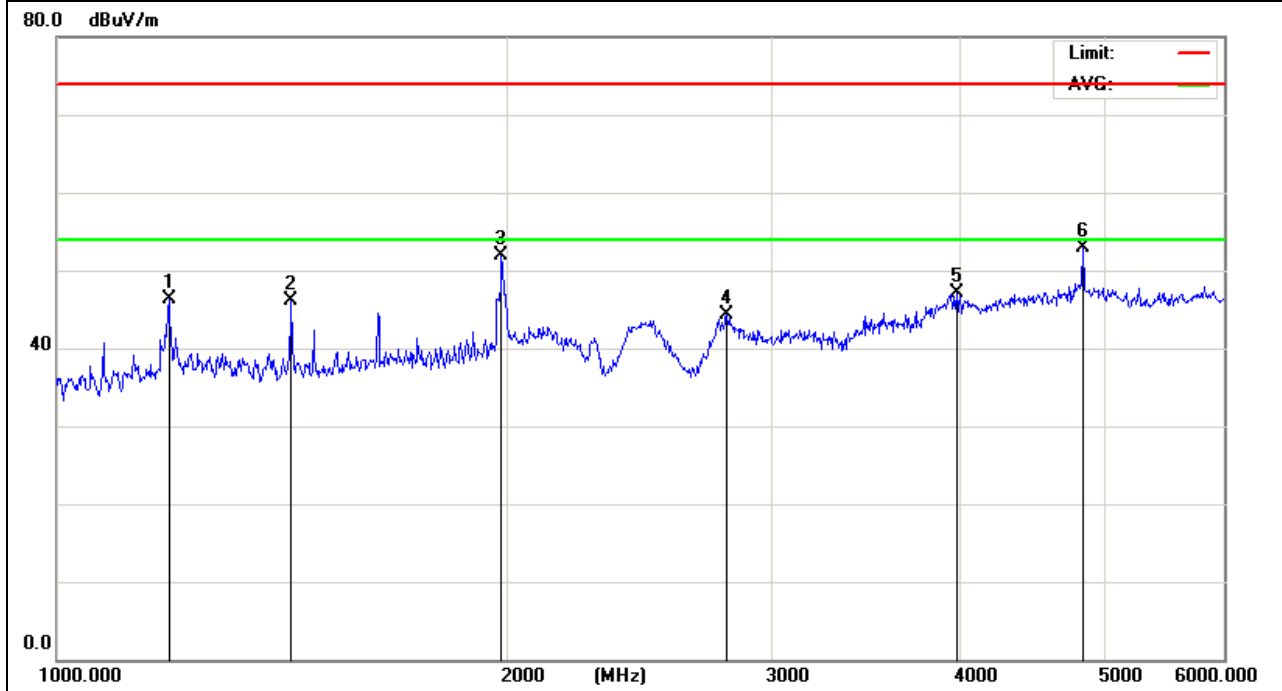

4. EUT TEST PHOTO

Radiated Measurement Photos

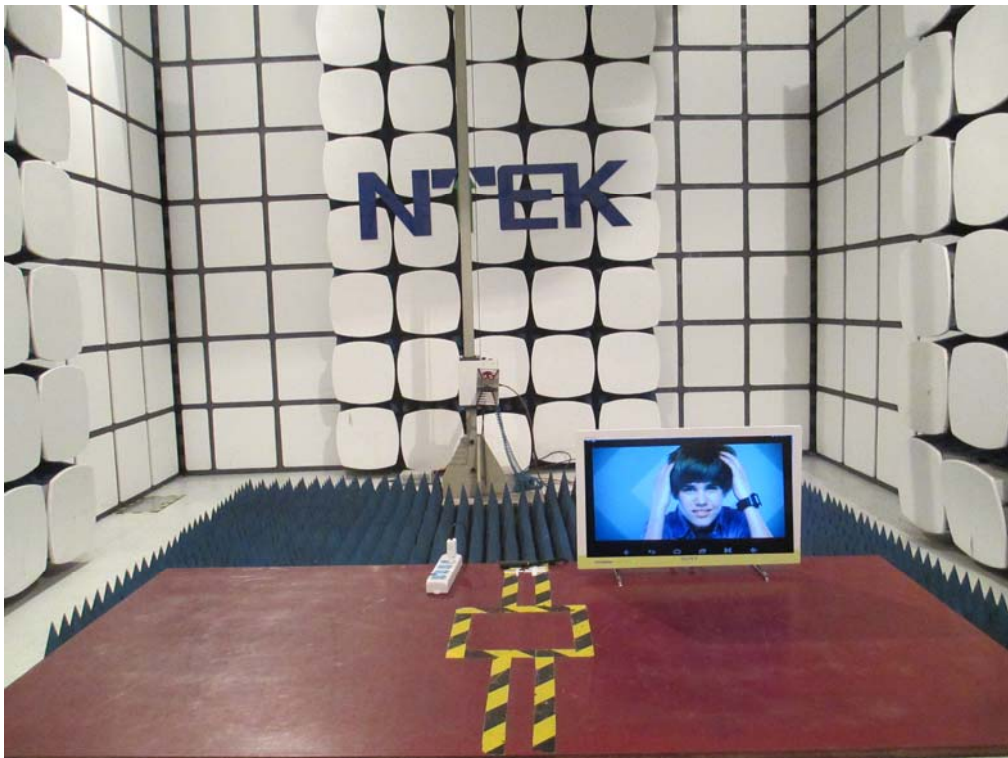
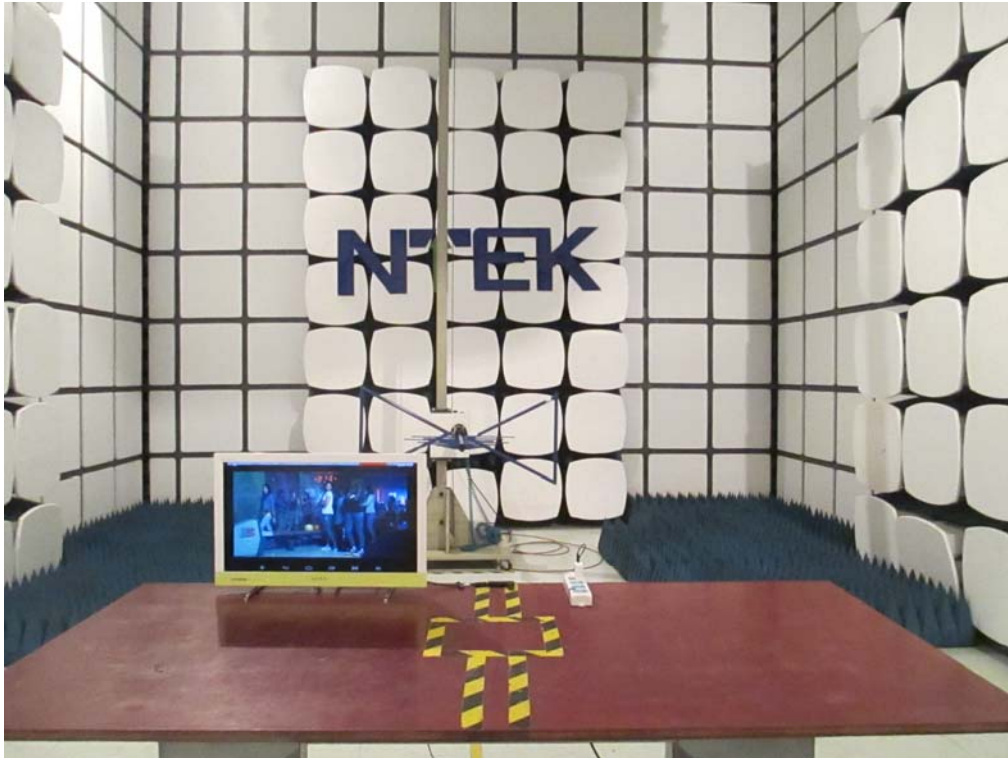

Conducted Measurement Photos

