

## Operation Theory of Actiontec GT704-WG

Here is the block diagram of GT704-WG. GT704-WG is a cost-effective full-rate ADSL Ethernet/USB Wireless Gateway. It provides four 10/100 Based Ethernet LAN port, one USB 1.1 device port, and an embedded 802.11G wireless Access Point. GT701-WG is based on TI's TNETD7300 Broadband Communication Processor , TNETW1130 802.11 MAC ,Baseband Processor and Marvell 88E6060 6-port 10/100 Ethernet switch

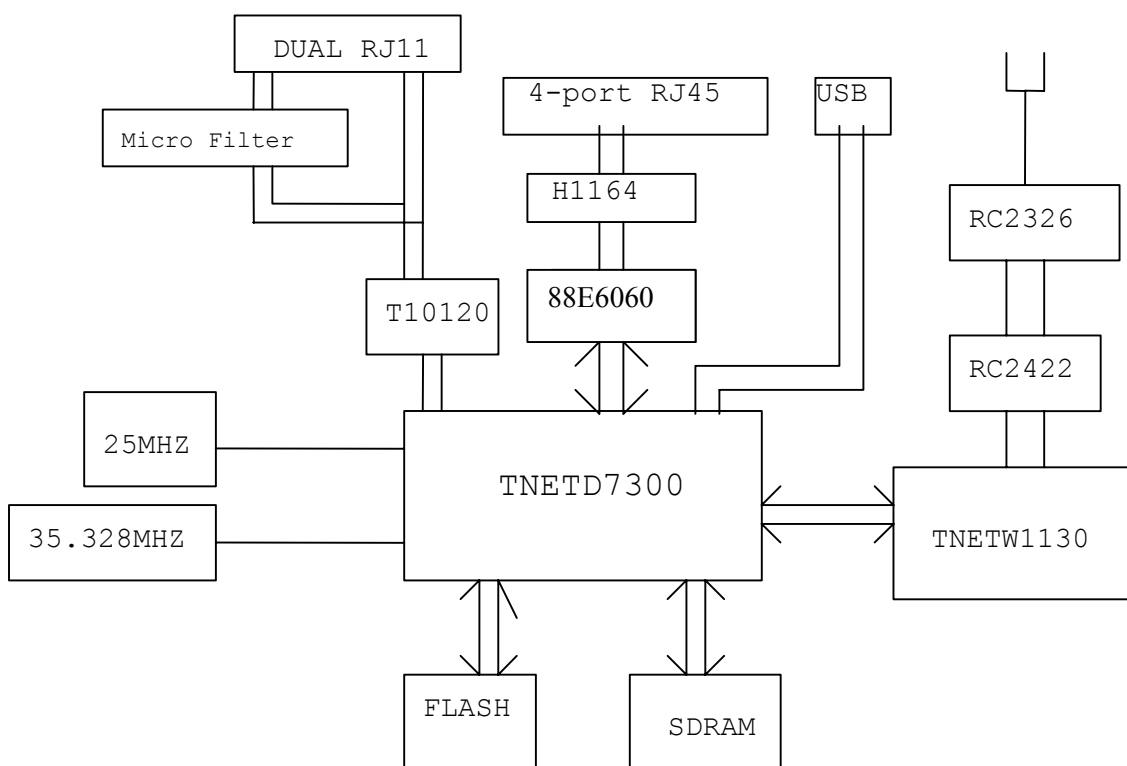

## **Broadband Communication Controller**

The Ethernet/USB Wireless Gateway uses TI's TNETD7300 as main chip. The control system is comprised of TNETD7300, Flash and SDRAM. The TNETD7300 is the most densely integrated system-on-a-chip ever offered to the ADSL CPE market by Texas Instruments. The TNETD7300 provides a total ADSL bridge/router solution. It integrates a broadband communications processor with ADSL physical layer, ADSL line driver, USB physical layer, Ethernet physical layer, and power management modules. It is an ideal ADSL CPE device for residential and small-office applications.

SDRAM: Store the program and data that run on CPU.

Flash: Store firmware and parameter used in processing.

## **Ethernet /USB and ADSL interfaces**

Ethernet interface uses Marvell 88E6060 6-port 10/100 Ethernet switch and H1164 Ethernet transformer. The transformer then connected to an 4-port RJ45 Ethernet connector.

USB interface also uses TNETD's physical layer and then connect to an USB connector. .

ADSL also uses TNETD's physical layer and T10120 ADSL transformer. The transformer is used for isolating and reducing common mode emissions. There is an on board micro filter, which allow a phone connect to the gateway directly.

## **802.11b/g Radio Path**

TNETW1130 is a 802.11 MAC and Baseband Processor. It is responsible for all 802.11b/g low layer process and interfaced with TNETD7300 and 802.11 radio chip set.

RC2422 and RC2326 is a complete 802.11b/g dual band WLAN two-chip radio. RC2422 is IQ/IF transceiver with dual VCO synthesizers and is designed to perform the IQ conversion at 374 MHZ IF as well as provide an RFLO and control logic to RC2326 RFFE (radio frequency front end). It uses a common IF frequency for both bands, which eliminates the need for an additional IF filter in dual band applications. While RC2326 is dual band RFFE and is designed to perform RF up and down conversions in the unlicensed ISM band. It includes the LNA, PA, mixer, bias circuit, RX gain control, transmit coupler and T/R switches.