

802.11ax-HE20 26dB Bandwidth

Channel 36 (5180MHz)

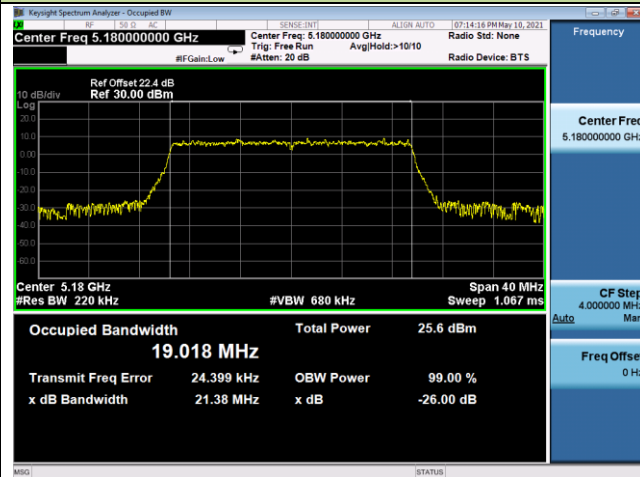

Channel 44 (5220MHz)

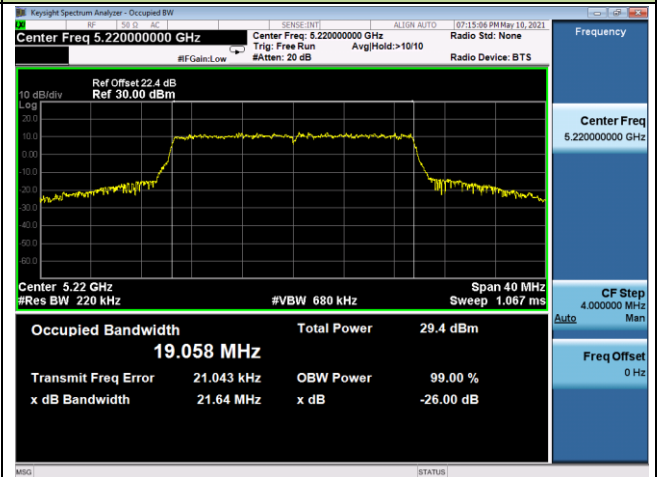

Channel 48 (5240MHz)



Channel 52 (5260MHz)

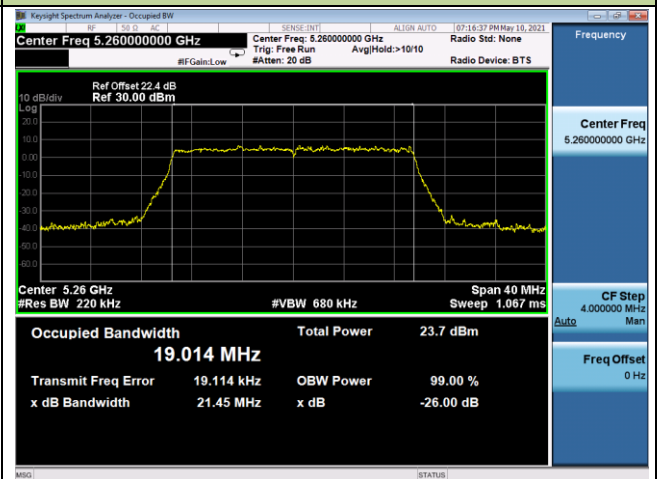

Channel 60 (5300MHz)

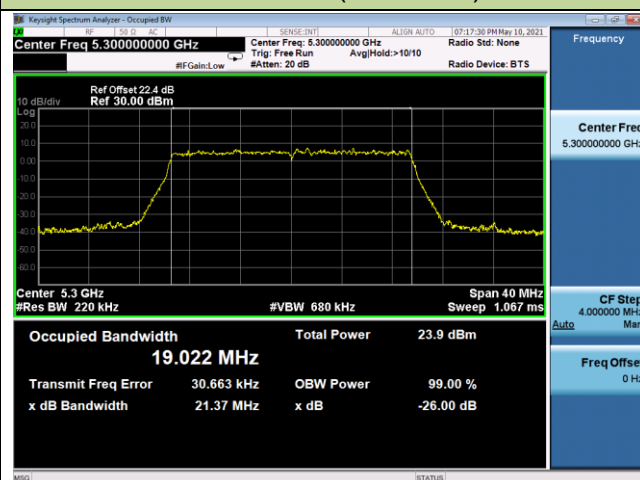

Channel 64 (5320MHz)

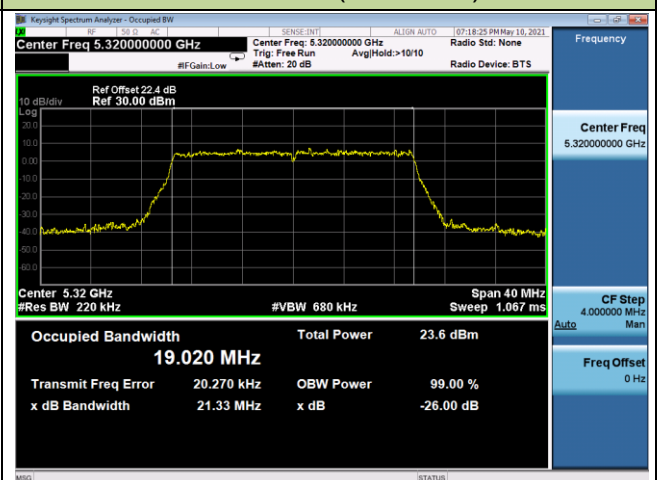

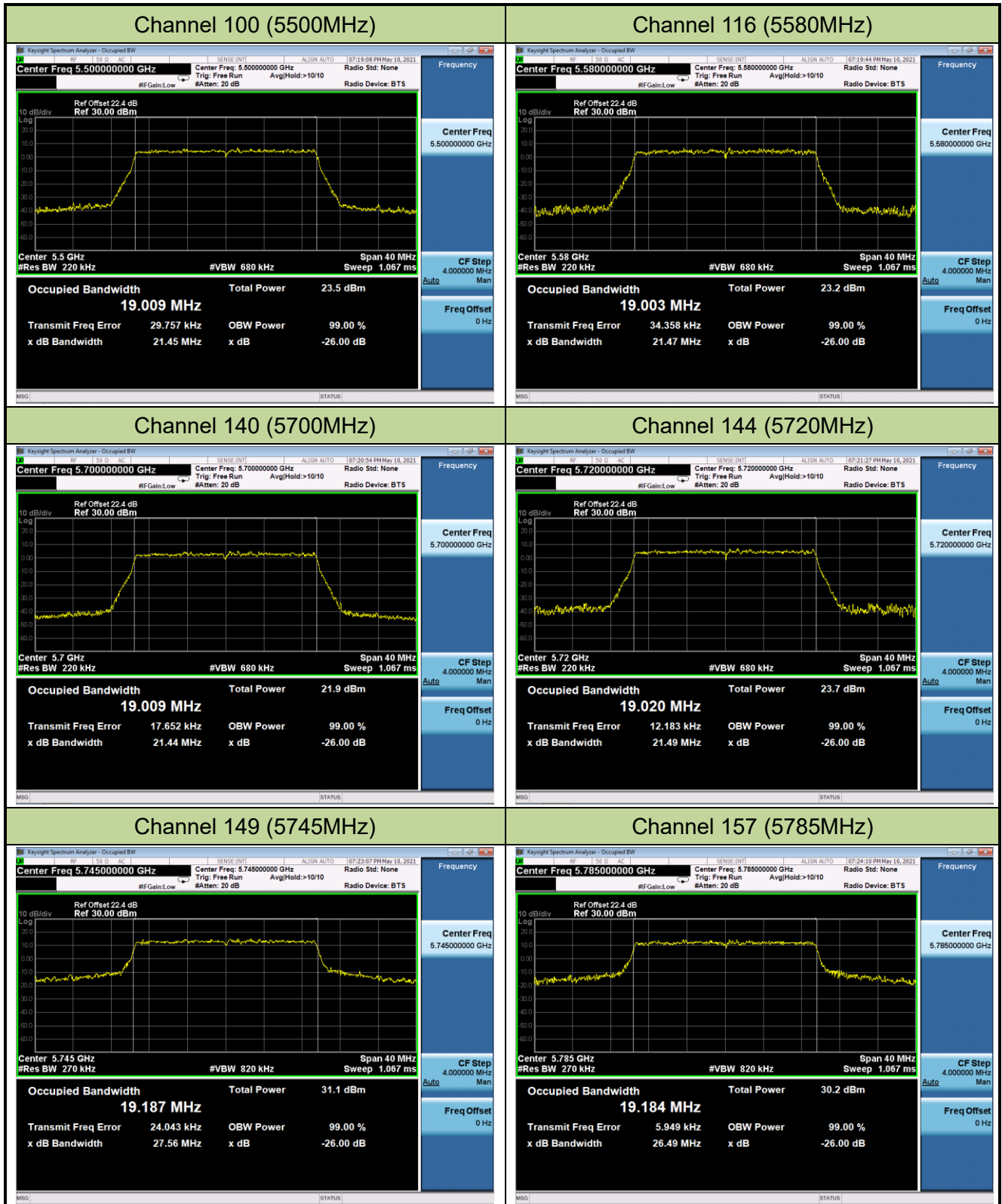

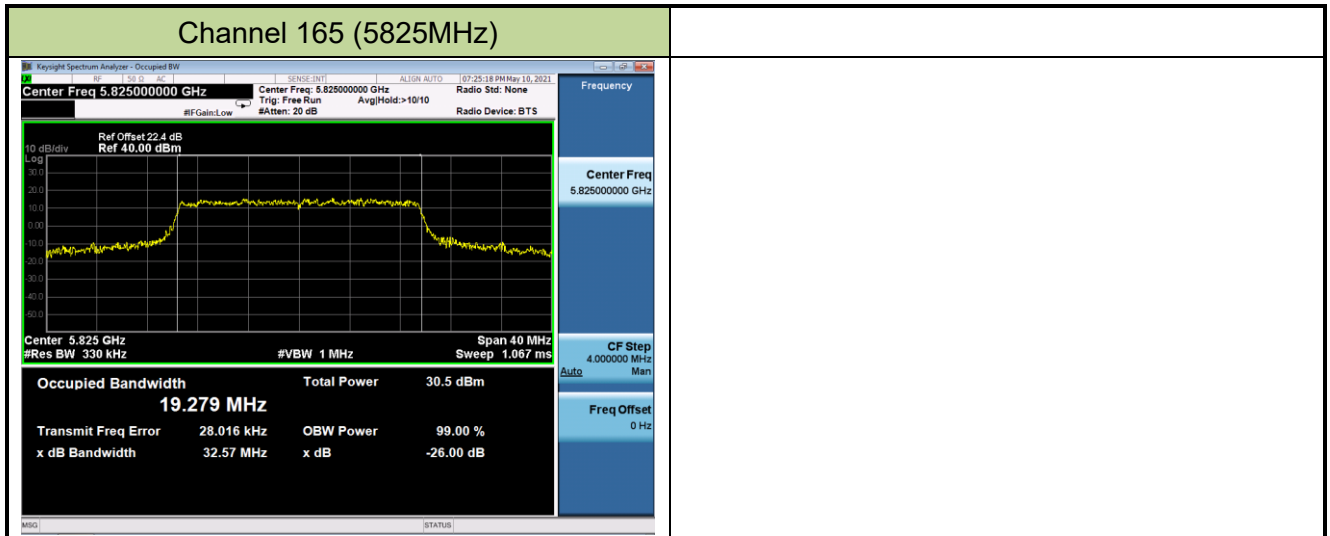

802.11ax-HE40 26dB Bandwidth

Channel 38 (5190MHz)

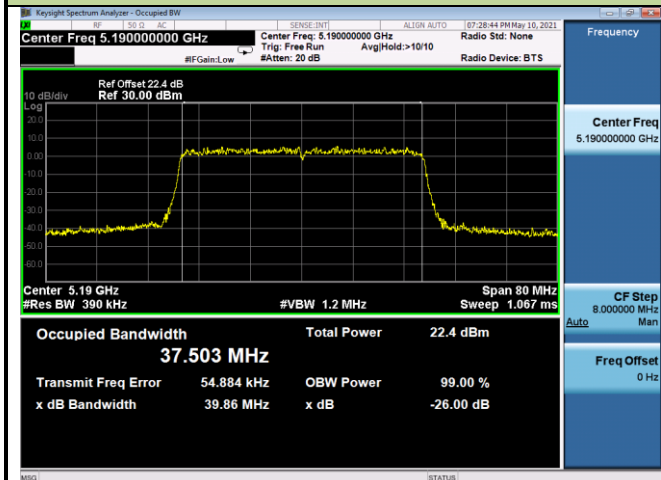

Channel 46 (5230MHz)

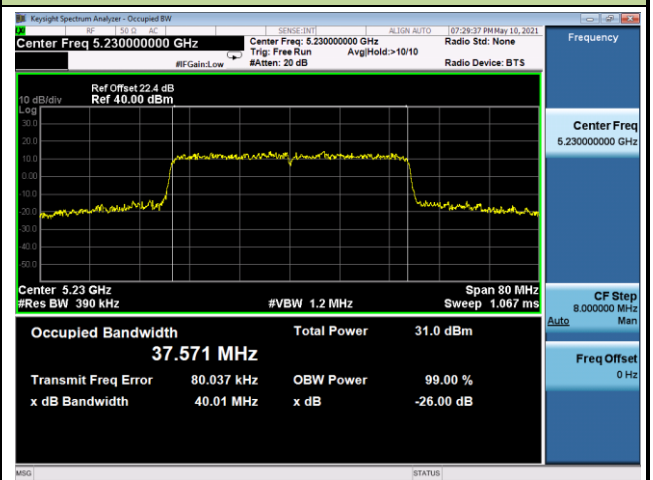

Channel 54 (5270MHz)

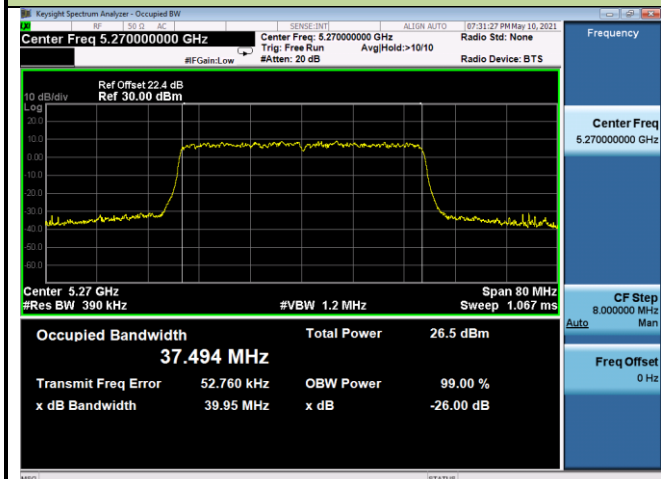

Channel 62 (5310MHz)

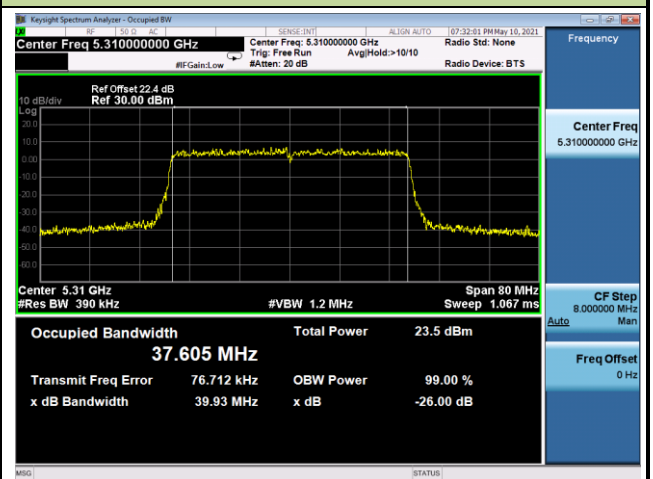

Channel 102 (5510MHz)

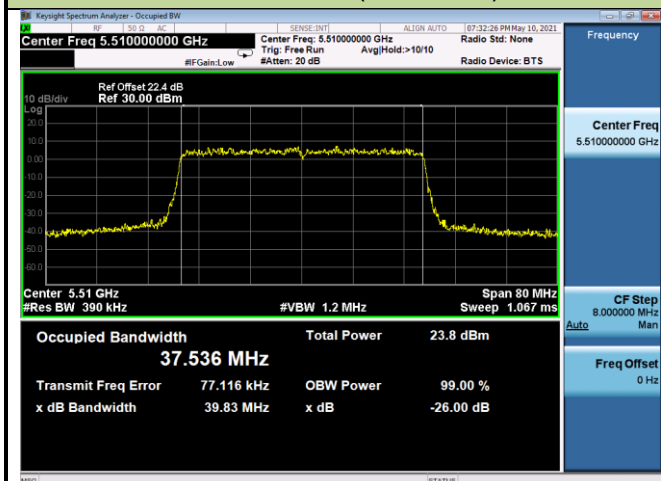

Channel 110 (5550MHz)

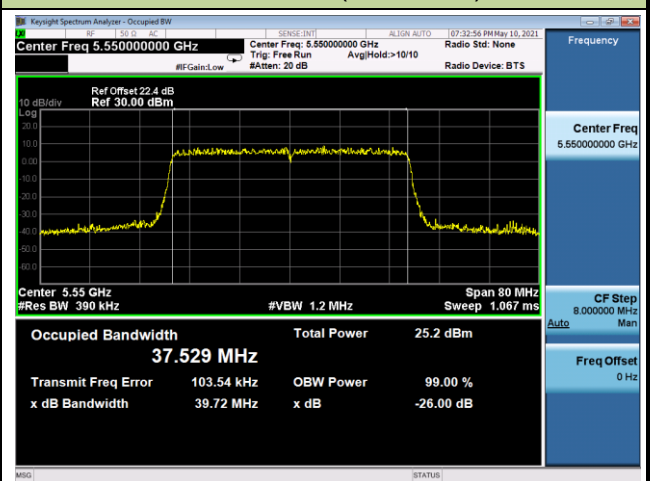

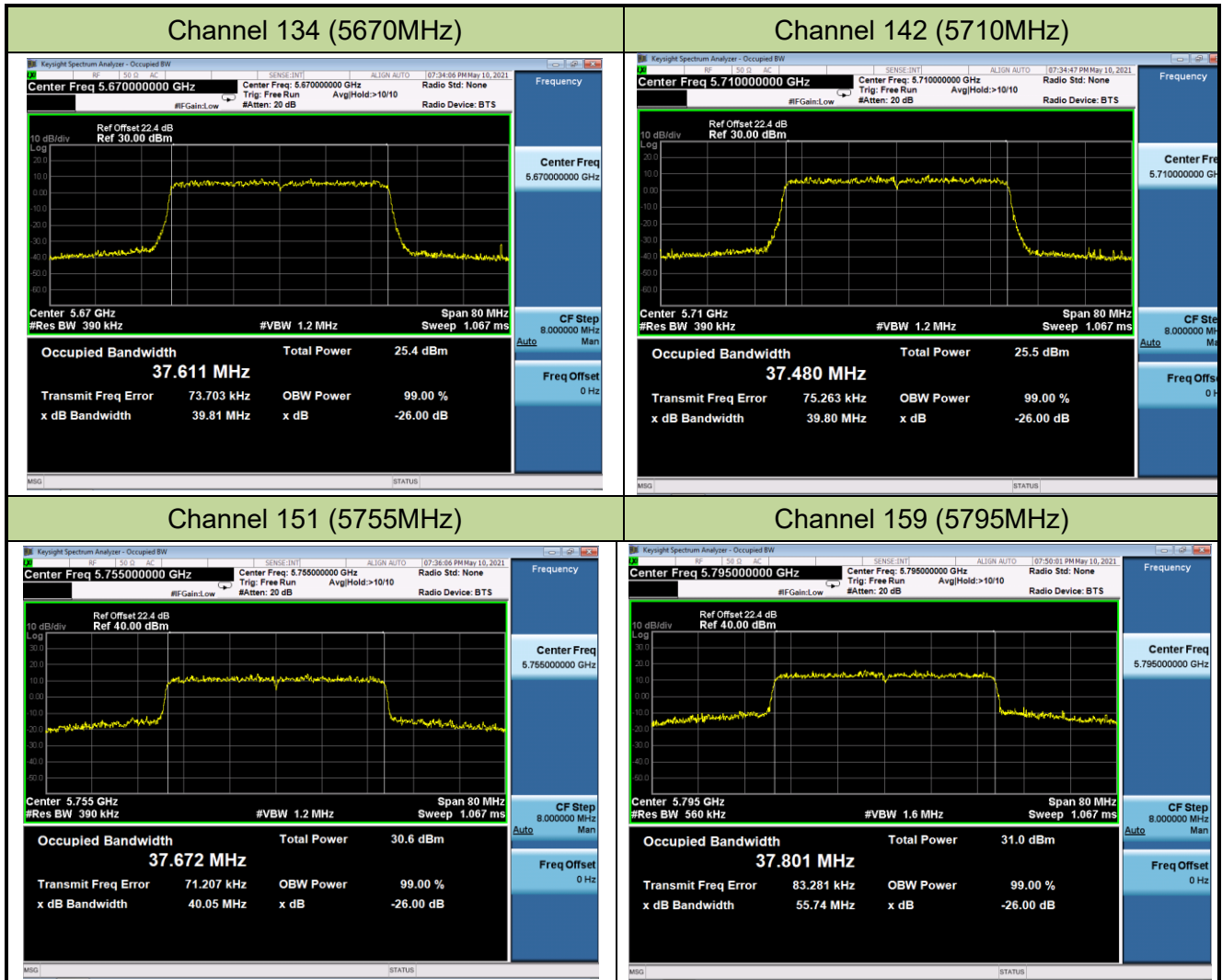

802.11ax-HE80 26dB Bandwidth

Channel 42 (5210MHz)

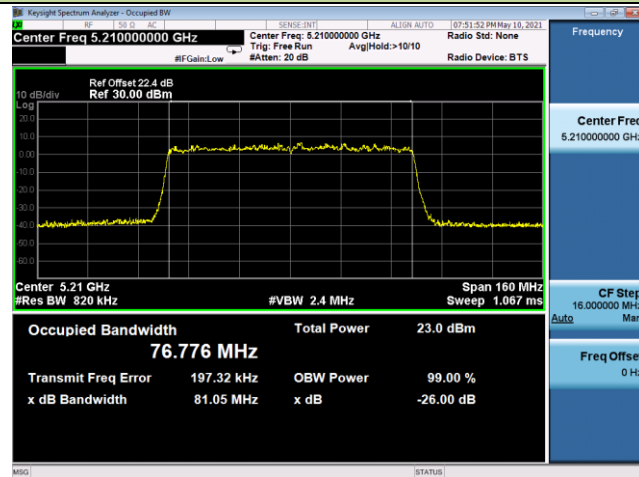

Channel 58 (5290MHz)

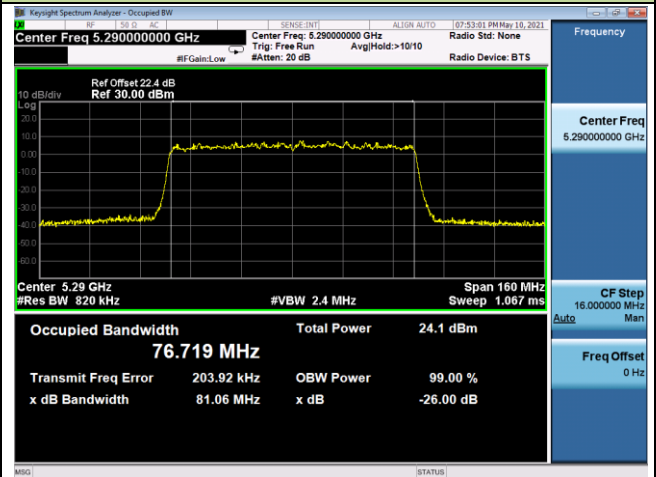

Channel 106 (5530MHz)

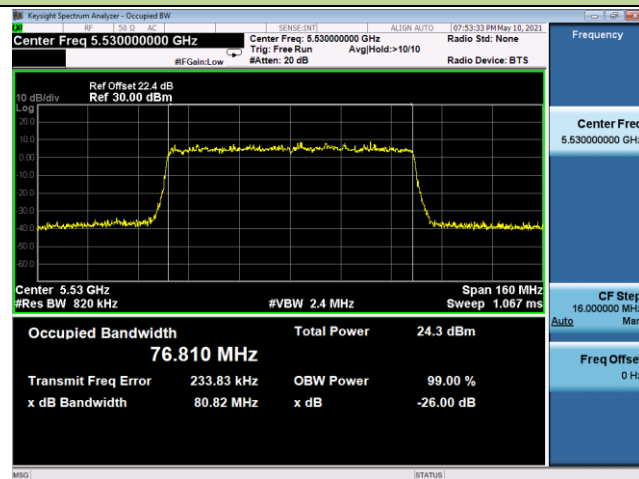

Channel 122 (5610MHz)

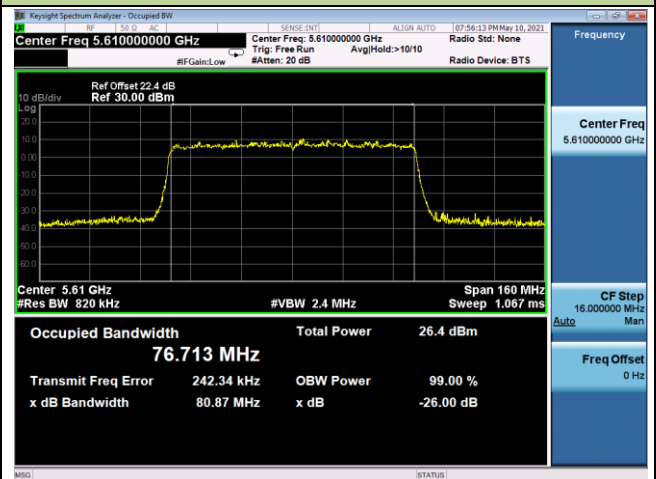

Channel 138 (5690MHz)

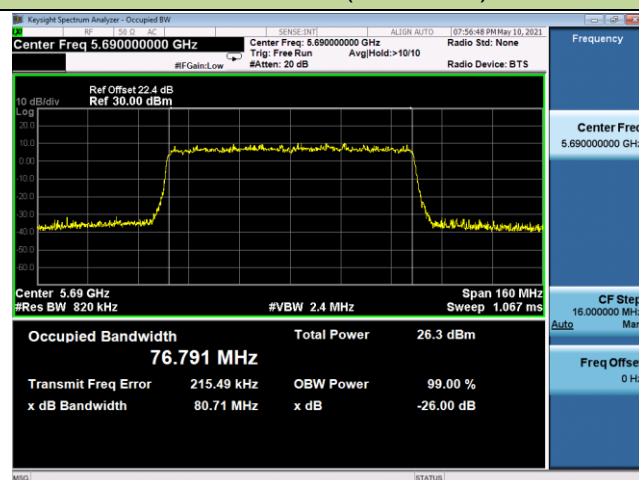

Channel 155 (5775MHz)

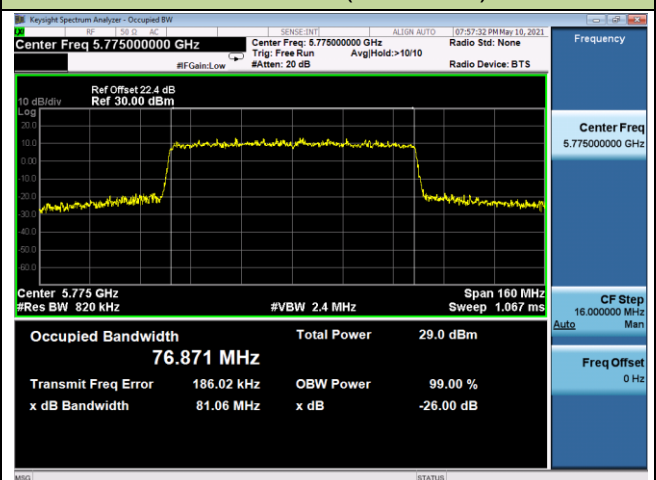

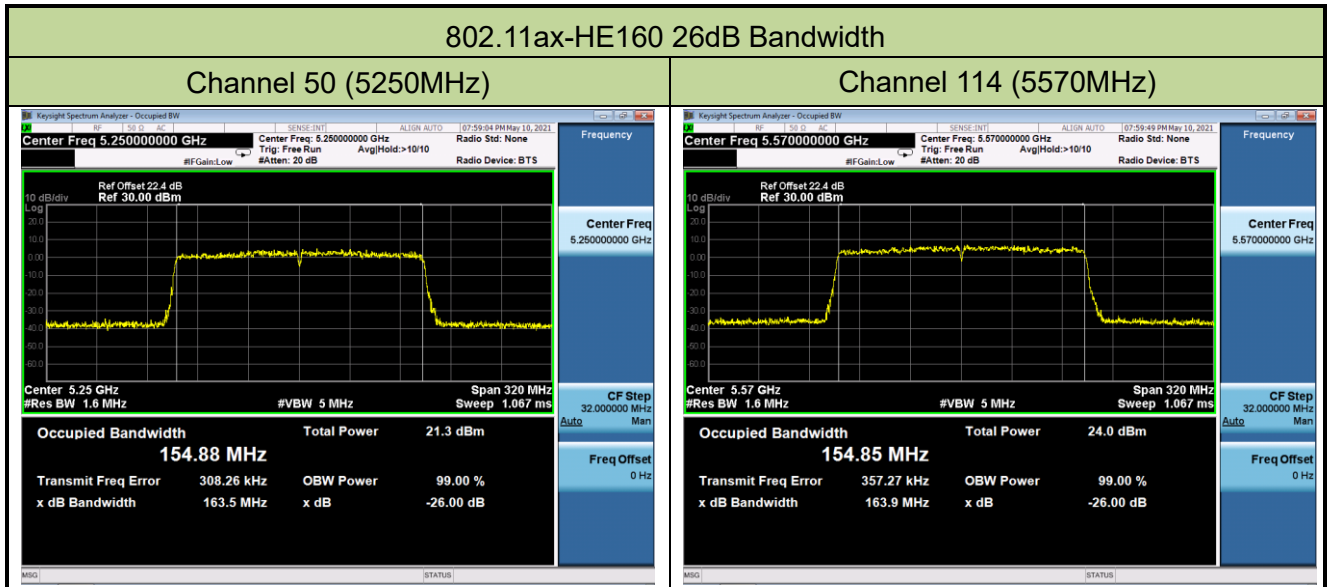

5.3. 6dB Bandwidth Measurement

5.3.1. Test Limit

The minimum 6dB bandwidth shall be at least 500 kHz.

5.3.2. Test Procedure

KDB 789033 D02v02r01 - Section C.2

5.3.3. Test Setting

1. Set center frequency to the nominal EUT channel center frequency.
2. RBW = 100 kHz.
3. VBW $\geq 3 \times$ RBW.
4. Detector = Peak.
5. Trace mode = Max hold.
6. Sweep = Auto couple.
7. Allow the trace to stabilize.
8. Measure the maximum width of the emission that is constrained by the frequencies associated with the two outermost amplitude points (upper and lower frequencies) that are attenuated by 6 dB relative to the maximum level measured in the fundamental emission.

5.3.4. Test Setup

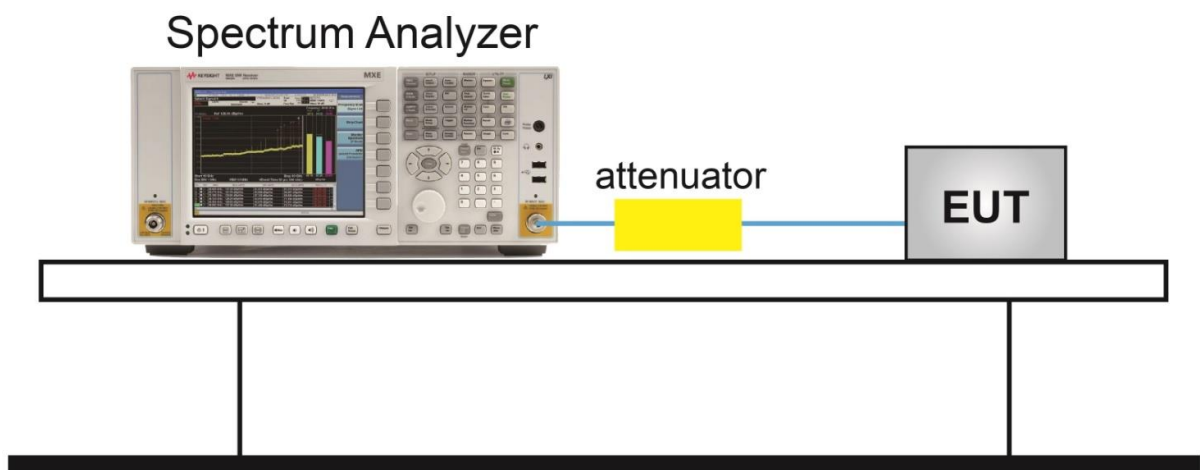

5.3.5. Test Result

Product	Kinetic VoIP Modem	Test Engineer	Yuri Li
Test Site	WZ-TR3	Test Date	2021/05/10

Test Mode	Data Rate/ MCS	Channel No.	Frequency (MHz)	6dB Bandwidth (MHz)	Limit (MHz)	Result
802.11a	6Mbps	149	5745	16.35	≥ 0.5	Pass
802.11a	6Mbps	157	5785	16.35	≥ 0.5	Pass
802.11a	6Mbps	165	5825	16.36	≥ 0.5	Pass
802.11ac-VHT20	MCS0	149	5745	17.57	≥ 0.5	Pass
802.11ac-VHT20	MCS0	157	5785	17.58	≥ 0.5	Pass
802.11ac-VHT20	MCS0	165	5825	17.59	≥ 0.5	Pass
802.11ac-VHT40	MCS0	151	5755	36.33	≥ 0.5	Pass
802.11ac-VHT40	MCS0	159	5795	35.33	≥ 0.5	Pass
802.11ac-VHT80	MCS0	155	5775	75.43	≥ 0.5	Pass
802.11ax-HE20	MCS0	149	5745	18.98	≥ 0.5	Pass
802.11ax-HE20	MCS0	157	5785	18.97	≥ 0.5	Pass
802.11ax-HE20	MCS0	165	5825	18.93	≥ 0.5	Pass
802.11ax-HE40	MCS0	151	5755	37.41	≥ 0.5	Pass
802.11ax-HE40	MCS0	159	5795	37.58	≥ 0.5	Pass
802.11ax-HE80	MCS0	155	5775	76.25	≥ 0.5	Pass

802.11a 6dB Bandwidth

Channel 149 (5745MHz)

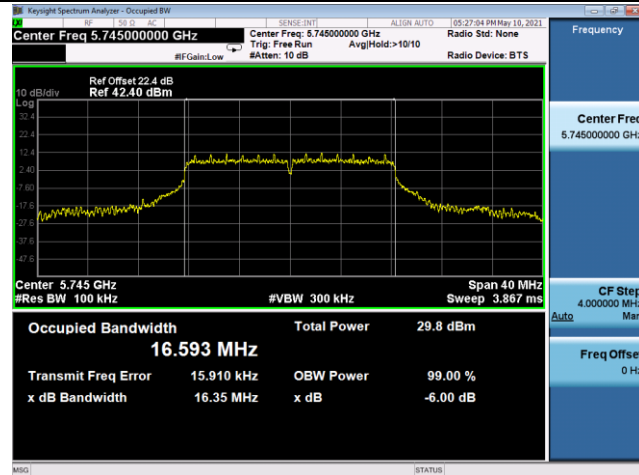

Channel 157 (5785MHz)

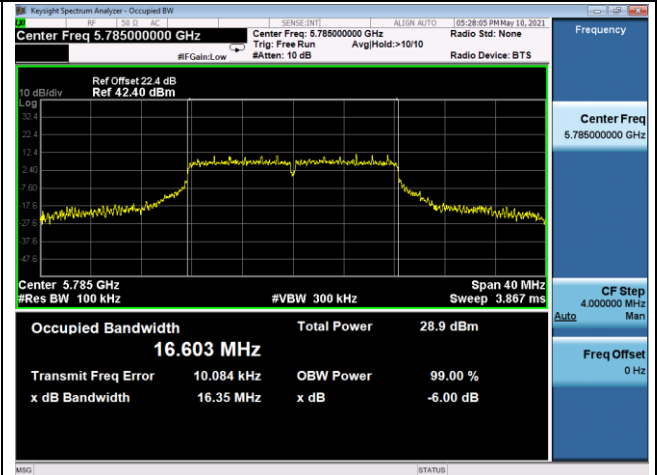

Channel 165 (5825MHz)

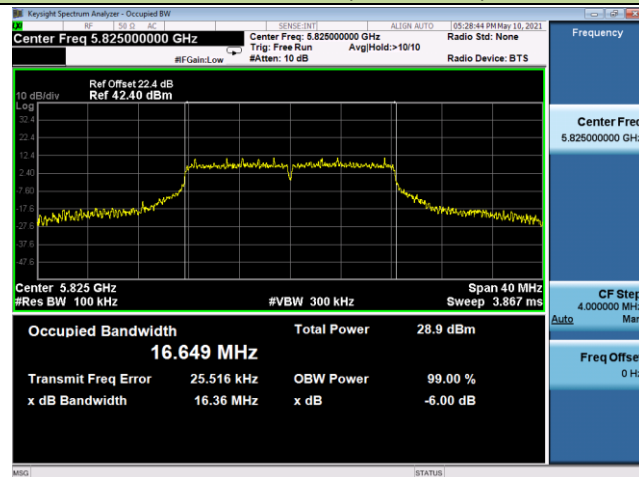

802.11ac-VHT20 6dB Bandwidth

Channel 149 (5745MHz)

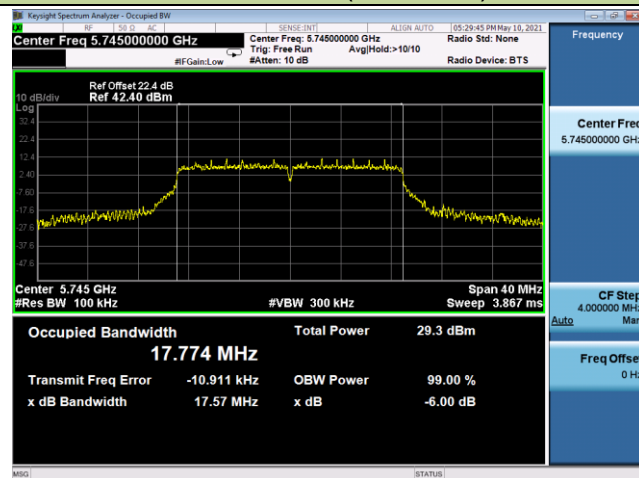

Channel 157 (5785MHz)

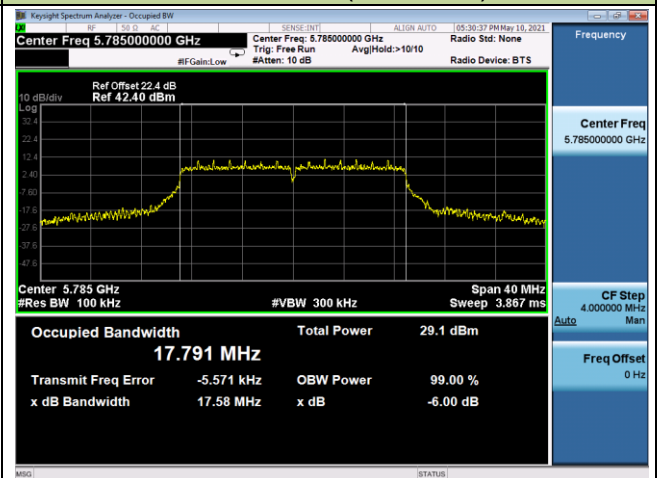

Channel 165 (5825MHz)

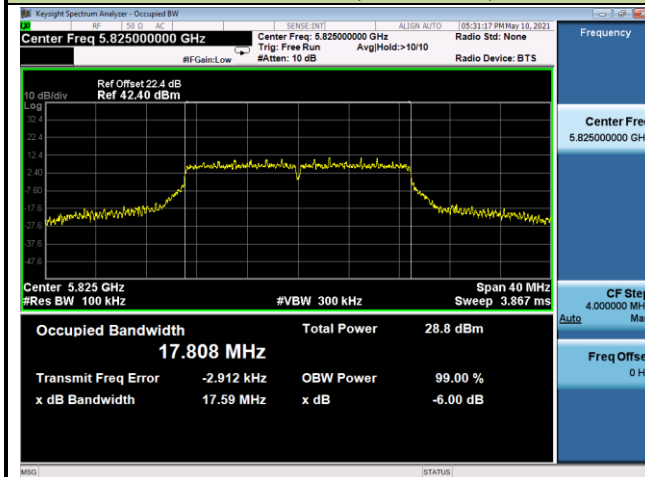

802.11ac-VHT40 6dB Bandwidth

Channel 151 (5755MHz)

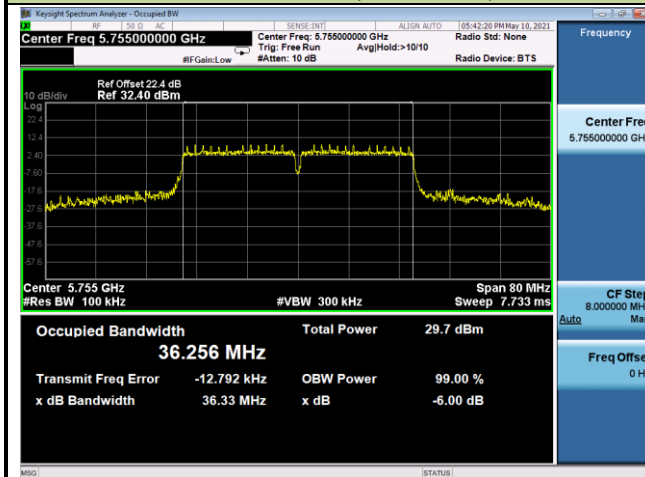

Channel 159 (5795MHz)

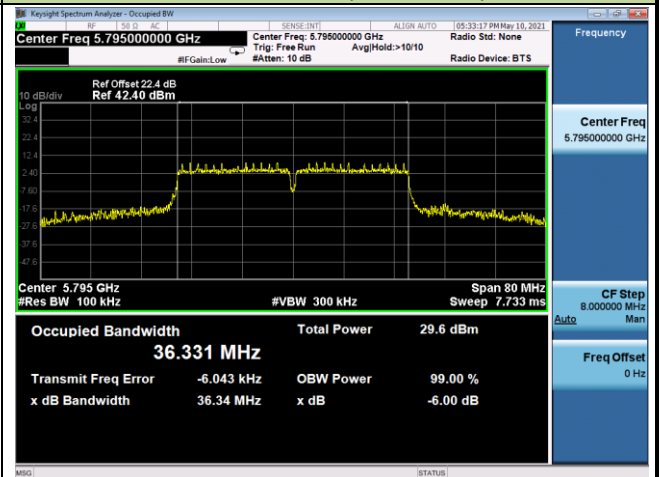

802.11ac-VHT80 6dB Bandwidth

Channel 155 (5775MHz)

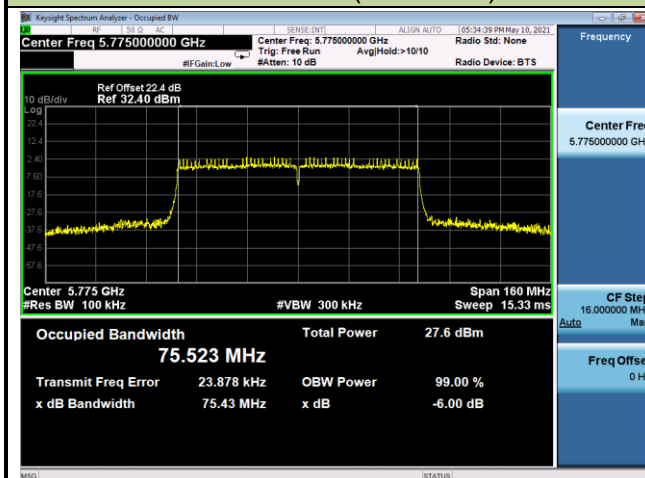

802.11ax-HE20 6dB Bandwidth

Channel 149 (5745MHz)

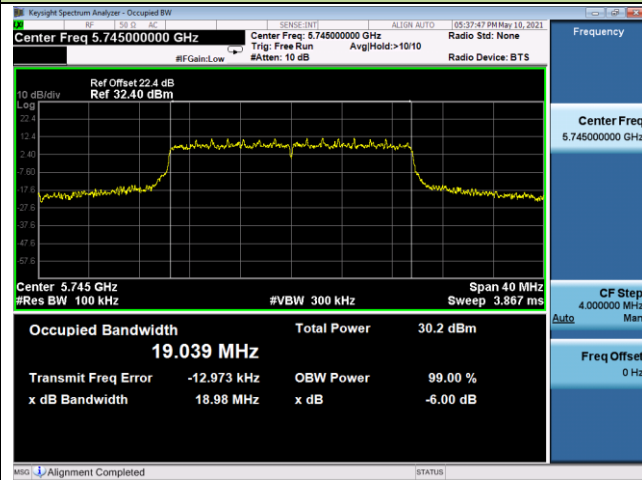

Channel 157 (5785MHz)

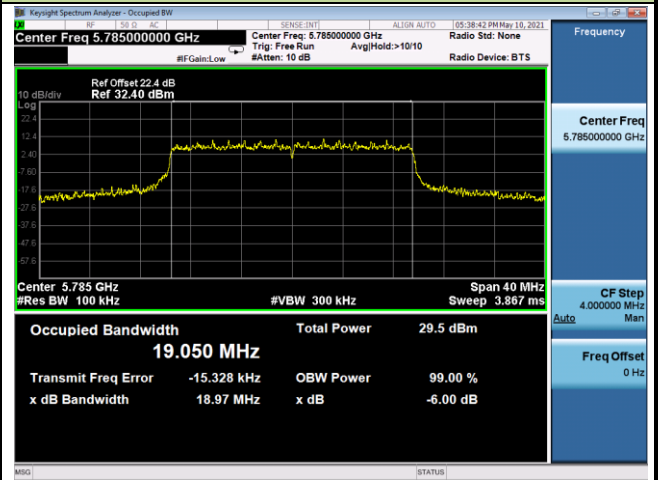

Channel 165 (5825MHz)

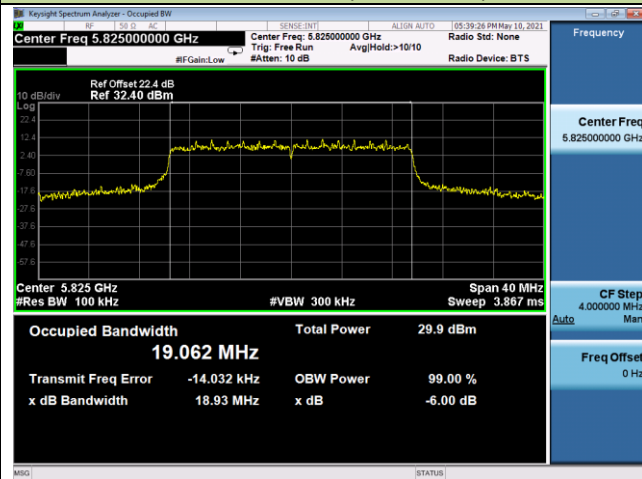

802.11ax-HE40 6dB Bandwidth

Channel 151 (5755MHz)

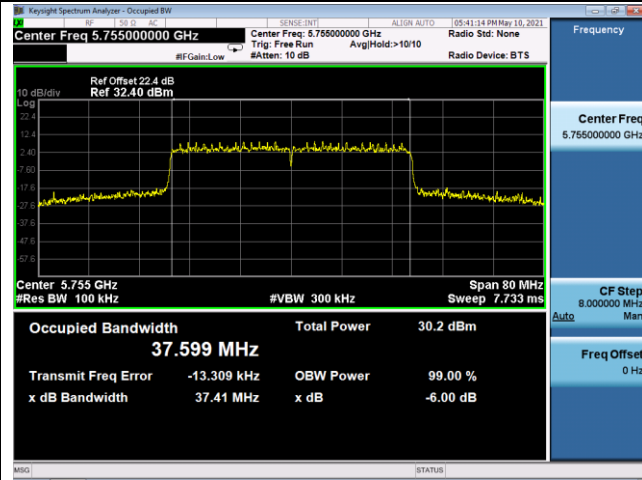

Channel 159 (5795MHz)

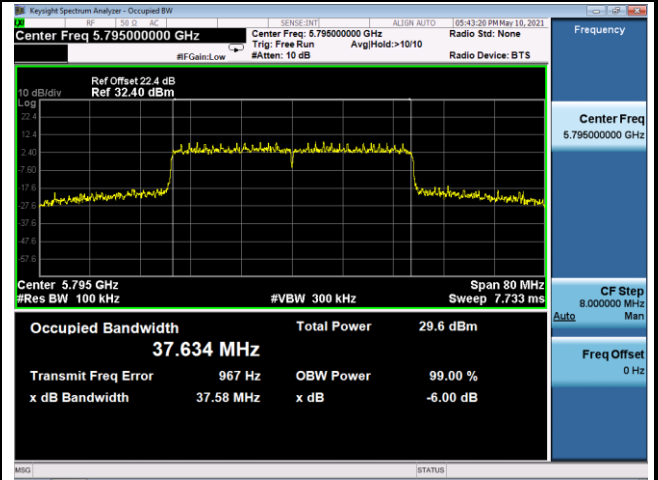

802.11ax-HE80 6dB Bandwidth

Channel 155 (5775MHz)

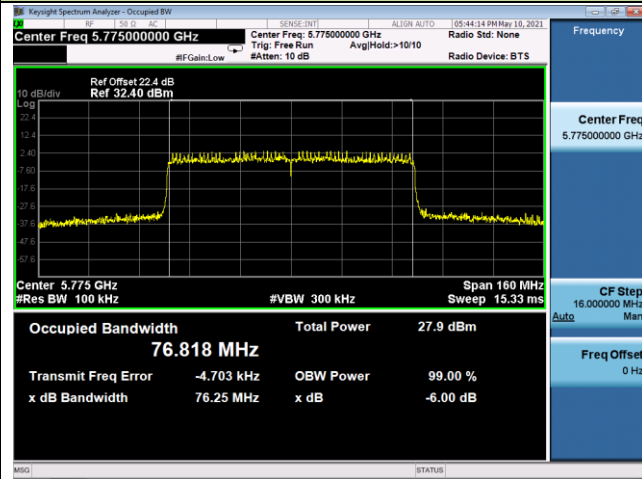

5.4. Output Power Measurement

5.4.1. Test Limit

For an indoor access point operating in the band 5.15-5.25 GHz, the maximum conducted output power over the frequency band of operation shall not exceed 1 W provided the maximum antenna gain does not exceed 6 dBi.

For an indoor access point operating in the band 5.25-5.35 GHz and 5.47-5.725 GHz bands, the maximum conducted output power over the frequency bands of operation shall not exceed the lesser of 250 mW (23.98dBm) or 11dBm +10 log (26dB BW).

For the band 5.725-5.85 GHz, the maximum conducted output power over the frequency band of operation shall not exceed 1 W (30dBm).

If transmitting antennas of directional gain greater than 6dBi are used, the maximum conducted output power shall be reduced by the amount in dB that the directional gain of the antenna exceeds 6dBi.

5.4.2. Test Procedure

KDB 789033D02v02r01- Section E)3)b) Method PM-G

5.4.3. Test Setting

Average power measurements were performed only when the EUT was transmitting at its maximum power control level using a broadband power meter with a pulse sensor. The power meter implemented triggering and gating capabilities which were set up such that power measurements were recorded only during the ON time of the transmitter.

5.4.4. Test Setup

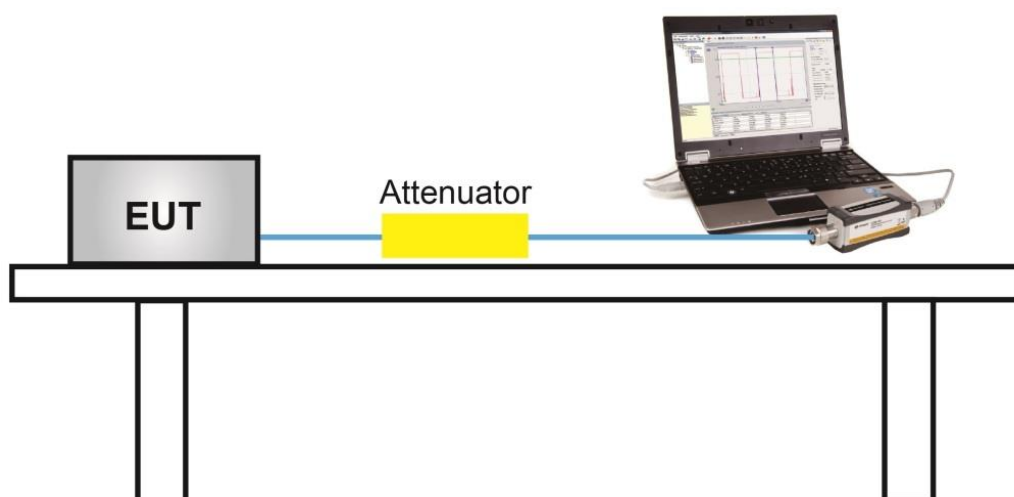

5.4.5. Test Result

Product	Kinetic VoIP Modem	Test Engineer	Yuri Li
Test Site	WZ-TR3	Test Date	2021/05/07

Test Mode	Data Rate/MCS	Ch. No.	Freq. (MHz)	Ant 0 Average Power (dBm)	Ant 1 Average Power (dBm)	Ant 2 Average Power (dBm)	Ant 3 Average Power (dBm)	Total Average Power (dBm)	Average Power Limit (dBm)	Result
11a	MCS0	36	5180	18.25	18.57	18.45	18.26	24.41	≤ 30.00	Pass
11a	MCS0	44	5220	21.40	21.86	21.35	20.64	27.35	≤ 30.00	Pass
11a	MCS0	48	5240	21.25	21.90	21.74	20.71	27.45	≤ 30.00	Pass
11a	6Mbps	52	5260	16.06	15.70	15.88	15.53	21.82	≤ 23.98	Pass
11a	6Mbps	60	5300	15.96	15.80	15.97	15.73	21.89	≤ 23.98	Pass
11a	6Mbps	64	5320	16.04	15.93	15.85	15.54	21.86	≤ 23.98	Pass
11a	6Mbps	100	5500	15.67	15.67	15.77	15.78	21.74	≤ 23.98	Pass
11a	6Mbps	116	5580	15.92	15.87	15.90	15.46	21.81	≤ 23.98	Pass
11a	6Mbps	140	5700	15.35	15.62	15.62	15.00	21.43	≤ 23.98	Pass
11a	6Mbps	144	5720	15.36	15.52	15.51	15.06	21.39	≤ 22.95	Pass
11a	6Mbps	149	5745	22.56	22.53	22.82	23.34	28.85	≤ 30.00	Pass
11a	6Mbps	157	5785	22.62	22.32	22.68	23.23	28.75	≤ 30.00	Pass
11a	6Mbps	165	5825	22.29	22.02	22.53	23.14	28.54	≤ 30.00	Pass
11ac-VHT20	MCS0	36	5180	19.80	20.20	19.89	19.15	25.80	≤ 30.00	Pass
11ac-VHT20	MCS0	44	5220	22.13	22.32	22.11	20.89	27.92	≤ 30.00	Pass
11ac-VHT20	MCS0	48	5240	21.80	22.20	22.08	21.08	27.83	≤ 30.00	Pass
11ac-VHT20	MCS0	52	5260	16.69	16.23	16.30	15.99	22.33	≤ 23.98	Pass
11ac-VHT20	MCS0	60	5300	16.21	16.09	16.24	15.84	22.12	≤ 23.98	Pass
11ac-VHT20	MCS0	64	5320	16.01	16.20	16.06	15.79	22.04	≤ 23.98	Pass
11ac-VHT20	MCS0	100	5500	16.10	16.20	16.23	16.25	22.22	≤ 23.98	Pass
11ac-VHT20	MCS0	116	5580	16.12	16.22	16.20	15.78	22.10	≤ 23.98	Pass
11ac-VHT20	MCS0	140	5700	15.78	15.98	16.31	15.54	21.93	≤ 23.98	Pass
11ac-VHT20	MCS0	144	5720	15.36	15.67	16.01	15.48	21.66	≤ 22.97	Pass
11ac-VHT20	MCS0	149	5745	22.63	22.60	22.92	23.46	28.94	≤ 30.00	Pass
11ac-VHT20	MCS0	157	5785	22.64	22.39	22.79	23.47	28.86	≤ 30.00	Pass
11ac-VHT20	MCS0	165	5825	22.49	22.27	22.75	23.38	28.76	≤ 30.00	Pass

Test Mode	Data Rate/MCS	Ch. No.	Freq. (MHz)	Ant 0 Average Power (dBm)	Ant 1 Average Power (dBm)	Ant 2 Average Power (dBm)	Ant 3 Average Power (dBm)	Total Average Power (dBm)	Average Power Limit (dBm)	Result
11ac-VHT40	MCS0	38	5190	15.24	15.12	15.37	15.14	21.24	≤ 30.00	Pass
11ac-VHT40	MCS0	46	5230	23.35	23.47	23.44	22.59	29.25	≤ 30.00	Pass
11ac-VHT40	MCS0	54	5270	17.87	17.67	17.81	17.56	23.75	≤ 23.98	Pass
11ac-VHT40	MCS0	62	5310	16.25	16.44	16.31	16.15	22.31	≤ 23.98	Pass
11ac-VHT40	MCS0	102	5510	17.16	16.95	16.90	16.92	23.00	≤ 23.98	Pass
11ac-VHT40	MCS0	110	5550	17.96	17.83	17.95	17.33	23.80	≤ 23.98	Pass
11ac-VHT40	MCS0	134	5670	17.71	18.05	17.70	17.56	23.78	≤ 23.98	Pass
11ac-VHT40	MCS0	142	5710	17.76	18.07	17.65	17.52	23.78	≤ 23.98	Pass
11ac-VHT40	MCS0	151	5755	22.84	22.74	23.41	22.58	28.92	≤ 30.00	Pass
11ac-VHT40	MCS0	159	5795	22.65	22.65	23.21	22.53	28.79	≤ 30.00	Pass
11ac-VHT80	MCS0	42	5210	14.62	14.47	14.41	14.50	20.52	≤ 30.00	Pass
11ac-VHT80	MCS0	58	5290	15.47	15.64	15.85	15.57	21.66	≤ 23.98	Pass
11ac-VHT80	MCS0	106	5530	15.63	15.43	15.78	15.61	21.63	≤ 23.98	Pass
11ac-VHT80	MCS0	122	5610	17.66	17.79	17.95	17.28	23.70	≤ 23.98	Pass
11ac-VHT80	MCS0	138	5690	17.78	17.88	18.02	17.41	23.80	≤ 23.98	Pass
11ac-VHT80	MCS0	155	5775	20.31	20.11	20.31	19.65	26.12	≤ 30.00	Pass
11ac-VHT160	MCS0	50	5250	13.61	13.88	14.00	14.02	19.90	≤ 23.98	Pass
11ac-VHT160	MCS0	114	5570	15.73	15.56	15.68	15.33	21.60	≤ 23.98	Pass
11ax-HE20	MCS0	36	5180	19.05	19.25	18.97	18.34	24.94	≤ 30.00	Pass
11ax-HE20	MCS0	44	5220	22.51	22.67	22.49	21.56	28.35	≤ 30.00	Pass
11ax-HE20	MCS0	48	5240	22.02	22.48	22.40	21.39	28.11	≤ 30.00	Pass
11ax-HE20	MCS0	52	5260	16.75	16.68	16.52	16.12	22.54	≤ 23.98	Pass
11ax-HE20	MCS0	60	5300	16.46	16.47	16.44	16.14	22.40	≤ 23.98	Pass
11ax-HE20	MCS0	64	5320	16.47	16.42	16.41	15.99	22.35	≤ 23.98	Pass
11ax-HE20	MCS0	100	5500	16.13	16.31	16.29	16.12	22.23	≤ 23.98	Pass
11ax-HE20	MCS0	116	5580	16.33	16.27	16.42	15.97	22.27	≤ 23.98	Pass
11ax-HE20	MCS0	140	5700	14.44	14.70	14.86	14.17	20.57	≤ 23.98	Pass
11ax-HE20	MCS0	144	5720	16.17	16.35	16.71	15.92	22.32	≤ 22.97	Pass
11ax-HE20	MCS0	149	5745	22.93	22.81	23.16	23.37	29.09	≤ 30.00	Pass
11ax-HE20	MCS0	157	5785	22.53	22.26	22.88	21.89	28.43	≤ 30.00	Pass
11ax-HE20	MCS0	165	5825	22.80	22.42	22.79	22.45	28.64	≤ 30.00	Pass

Test Mode	Data Rate/MCS	Ch. No.	Freq. (MHz)	Ant 0 Average Power (dBm)	Ant 1 Average Power (dBm)	Ant 2 Average Power (dBm)	Ant 3 Average Power (dBm)	Total Average Power (dBm)	Average Power Limit (dBm)	Result
11ax-HE40	MCS0	38	5190	15.02	14.71	15.04	14.88	20.94	≤ 30.00	Pass
11ax-HE40	MCS0	46	5230	23.38	23.52	23.44	22.32	29.21	≤ 30.00	Pass
11ax-HE40	MCS0	54	5270	17.92	17.89	17.94	17.48	23.83	≤ 23.98	Pass
11ax-HE40	MCS0	62	5310	15.83	16.36	16.44	16.10	22.21	≤ 23.98	Pass
11ax-HE40	MCS0	102	5510	16.22	16.23	16.08	15.86	22.12	≤ 23.98	Pass
11ax-HE40	MCS0	110	5550	17.92	17.61	17.85	17.51	23.75	≤ 23.98	Pass
11ax-HE40	MCS0	134	5670	17.34	17.93	17.56	17.03	23.50	≤ 23.98	Pass
11ax-HE40	MCS0	142	5710	17.65	17.90	17.33	17.59	23.64	≤ 23.98	Pass
11ax-HE40	MCS0	151	5755	22.76	22.72	23.18	22.47	28.81	≤ 30.00	Pass
11ax-HE40	MCS0	159	5795	22.72	22.53	22.81	22.25	28.60	≤ 30.00	Pass
11ax-HE80	MCS0	42	5210	14.36	14.43	14.31	14.49	20.42	≤ 30.00	Pass
11ax-HE80	MCS0	58	5290	14.92	15.75	15.77	15.64	21.55	≤ 23.98	Pass
11ax-HE80	MCS0	106	5530	16.36	16.21	16.43	16.17	22.31	≤ 23.98	Pass
11ax-HE80	MCS0	122	5610	17.68	17.65	18.00	17.33	23.69	≤ 23.98	Pass
11ax-HE80	MCS0	138	5690	17.77	17.80	17.97	17.31	23.74	≤ 23.98	Pass
11ax-HE80	MCS0	155	5775	20.68	20.56	20.86	19.76	26.51	≤ 30.00	Pass
11ax-HE160	MCS0	50	5250	13.36	13.38	13.48	13.61	19.48	≤ 23.98	Pass
11ax-HE160	MCS0	114	5570	15.28	15.10	15.13	15.16	21.19	≤ 23.98	Pass

Note: Total Average Power (dBm) = $10 \cdot \log \{10^{(\text{ANT 0 Average Power} / 10)} + 10^{(\text{ANT 1 Average Power} / 10)} + 10^{(\text{ANT 2 Average Power} / 10)} + 10^{(\text{ANT 3 Average Power} / 10)}\}$ (dBm).

For 5720MHz, Power Limit = $11 + 10 \cdot \log(\text{BW}_{(26\text{dBc})} / 2 + 5\text{MHz})$.

5.5. Transmit Power Control

5.5.1. Test Limit

The U-NII device is required to have the capability to operate at least 6 dB below the mean EIRP value of 30 dBm.

5.5.2. Test Procedure Used

KDB 789033 D02v01- Section E)3)b) Method PM-G

5.5.3. Test Setting

Average power measurements were performed only when the EUT was transmitting at its maximum power control level using a broadband power meter with a pulse sensor. The power meter implemented triggering and gating capabilities which were set up such that power measurements were recorded only during the ON time of the transmitter. The trace was averaged over 100 traces to obtain the final measured average power.

5.5.4. Test Setup

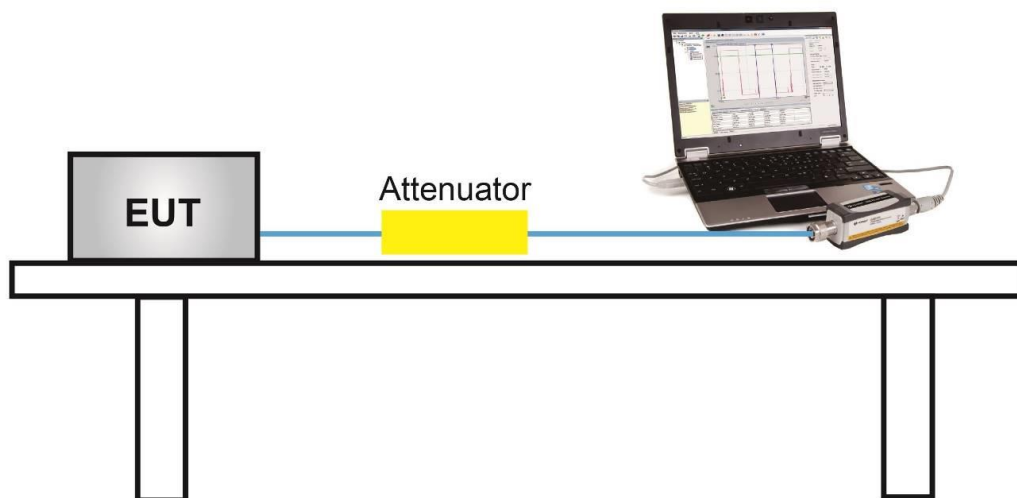

5.5.5. Test Result

Device supports TPC mechanism, details refer to the operational description.

5.6. Power Spectral Density Measurement

5.6.1. Test Limit

For an indoor access point operating in the band 5.15-5.25 GHz, the maximum power spectral density shall not exceed 17 dBm in any 1MHz band.

For the band 5.25-5.35 GHz and 5.47-5.725 GHz bands, the maximum power spectral density shall not exceed 11 dBm in any 1MHz band.

For the band 5.725-5.85 GHz, the maximum power spectral density shall not exceed 30 dBm in any 500-kHz band.

If transmitting antennas of directional gain greater than 6dBi are used, the peak power spectral density shall be reduced by the amount in dB that the directional gain of the antenna exceeds 6dBi.

5.6.2. Test Procedure

KDB 789033 D02v02r01 - Section F

5.6.3. Test Setting

1. Analyzer was set to the center frequency of the UNII channel under investigation
2. Span was set to encompass the entire 26dB EBW of the signal.
3. RBW = 1MHz, VBW \geq 3*RBW for U-NII-1, U-NII-2A, and U-NII-2C;
RBW = 510kHz; VBW \geq 3*RBW for U-NII-3;
4. Number of sweep points \geq 2 × (span / RBW)
5. Detector = power averaging (Average)
6. Sweep time = auto
7. Trigger = free run
8. Use the peak search function on the instrument to find the peak of the spectrum and record its value.
9. Add $10 \cdot \log(1/x)$, where x is the duty cycle, to the measured power in order to compute the average power during the actual transmission times (because the measurement represents an average over both the on and off times of the transmission). For example, add $10 \cdot \log(1/0.25) = 6$ dB if the duty cycle is 25 percent.

5.6.4. Test Setup

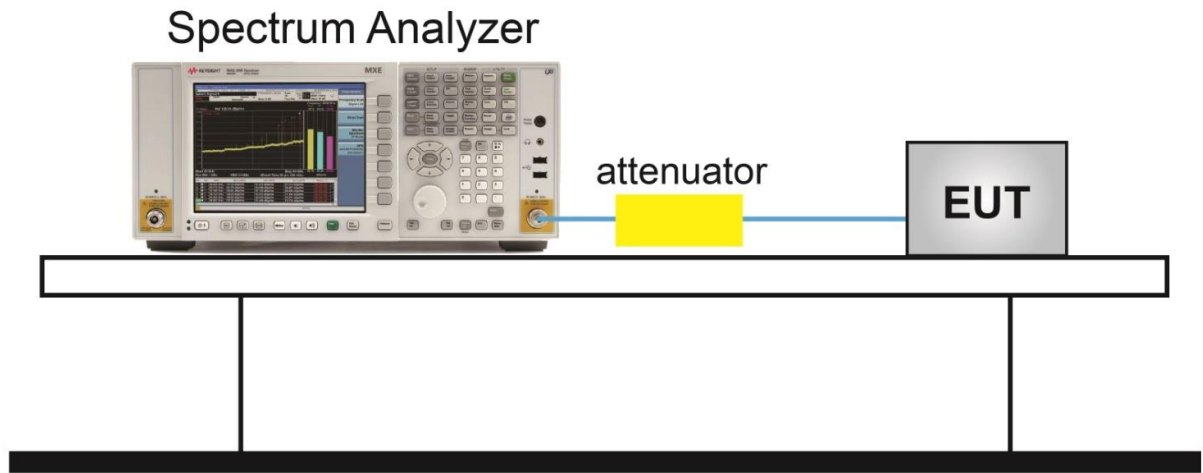

5.6.5. Test Result

Product	Kinetic VoIP Modem	Test Engineer	Luis Yang
Test Site	WZ-TR3	Test Date	2021/05/06~05/08

Test Mode	Data Rate/MCS	Ch. No.	Freq. (MHz)	Ant 0PSD (dBm/MHz)	Ant 1 PSD (dBm/MHz)	Ant 2 PSD (dBm/MHz)	Ant 3 PSD (dBm/MHz)	Duty Cycle (%)	Total PSD (dBm/MHz)	PSD Limit (dBm/MHz)	Result
For NII-1, NII-2A, NII-2C Band:											
11a	6Mbps	36	5180	7.63	7.65	7.36	6.86	94.93	13.63	≤ 16.81	Pass
11a	6Mbps	44	5220	10.39	10.53	10.27	9.62	94.93	16.46	≤ 16.81	Pass
11a	6Mbps	48	5240	10.50	10.57	10.39	9.40	94.93	16.49	≤ 16.81	Pass
11a	6Mbps	52	5260	4.59	4.46	4.21	4.29	94.93	10.64	≤ 10.81	Pass
11a	6Mbps	60	5300	4.21	4.51	4.54	4.63	94.93	10.72	≤ 10.81	Pass
11a	6Mbps	64	5320	4.42	4.27	4.65	4.51	94.93	10.71	≤ 10.81	Pass
11a	6Mbps	100	5500	4.27	4.20	4.21	4.41	94.93	10.52	≤ 10.88	Pass
11a	6Mbps	116	5580	4.45	4.37	4.51	4.40	94.93	10.68	≤ 10.88	Pass
11a	6Mbps	120	5600	4.43	4.49	4.50	4.38	94.93	10.70	≤ 10.88	Pass
11a	6Mbps	140	5700	4.39	4.51	4.46	4.31	94.93	10.66	≤ 10.88	Pass
11a	6Mbps	144	5720	4.00	4.35	4.53	4.31	94.93	10.55	≤ 10.88	Pass
11ac-VHT20	MCS0	36	5180	7.79	8.31	8.48	8.21	97.86	14.32	≤ 16.81	Pass
11ac-VHT20	MCS0	44	5220	10.46	10.37	10.28	9.54	97.86	16.29	≤ 16.81	Pass
11ac-VHT20	MCS0	48	5240	10.33	10.59	10.77	9.80	97.86	16.50	≤ 16.81	Pass
11ac-VHT20	MCS0	52	5260	4.55	4.47	4.35	4.49	97.86	10.58	≤ 10.81	Pass
11ac-VHT20	MCS0	60	5300	4.51	4.42	4.62	4.53	97.86	10.64	≤ 10.81	Pass
11ac-VHT20	MCS0	64	5320	4.57	4.31	4.52	4.60	97.86	10.62	≤ 10.81	Pass
11ac-VHT20	MCS0	100	5500	4.69	4.44	4.47	4.62	97.86	10.67	≤ 10.88	Pass
11ac-VHT20	MCS0	116	5580	4.28	4.38	4.49	4.34	97.86	10.49	≤ 10.88	Pass
11ac-VHT20	MCS0	120	5600	4.37	4.44	4.77	4.32	97.86	10.59	≤ 10.88	Pass
11ac-VHT20	MCS0	140	5700	4.34	4.54	4.71	4.25	97.86	10.58	≤ 10.88	Pass
11ac-VHT20	MCS0	144	5720	4.12	4.41	4.81	4.35	97.86	10.54	≤ 10.88	Pass

Test Mode	Data Rate/MCS	Ch. No.	Freq. (MHz)	Ant 0PSD (dBm/MHz)	Ant 1 PSD (dBm/MHz)	Ant 2 PSD (dBm/MHz)	Ant 3 PSD (dBm/MHz)	Duty Cycle (%)	Total PSD (dBm/MHz)	PSD Limit (dBm/MHz)	Result
11ac-VHT40	MCS0	38	5190	0.72	0.89	0.63	0.52	96.72	6.86	≤ 16.81	Pass
11ac-VHT40	MCS0	46	5230	8.69	8.81	9.20	7.99	96.72	14.86	≤ 16.81	Pass
11ac-VHT40	MCS0	54	5270	3.30	3.24	3.32	3.24	96.72	9.44	≤ 10.81	Pass
11ac-VHT40	MCS0	62	5310	1.90	2.20	2.17	2.01	96.72	8.24	≤ 10.81	Pass
11ac-VHT40	MCS0	102	5510	2.68	2.95	2.89	2.43	96.72	8.91	≤ 10.88	Pass
11ac-VHT40	MCS0	110	5550	3.56	3.43	3.65	3.08	96.72	9.60	≤ 10.88	Pass
11ac-VHT40	MCS0	118	5590	3.46	3.77	3.68	3.19	96.72	9.70	≤ 10.88	Pass
11ac-VHT40	MCS0	134	5670	3.35	3.81	3.42	3.10	96.72	9.59	≤ 10.88	Pass
11ac-VHT40	MCS0	142	5710	3.47	4.00	3.81	3.35	96.72	9.83	≤ 10.88	Pass
11ac-VHT80	MCS0	42	5210	-3.00	-2.91	-2.53	-3.30	93.66	3.38	≤ 16.81	Pass
11ac-VHT80	MCS0	58	5290	-1.80	-1.33	-1.60	-1.91	93.66	4.65	≤ 10.81	Pass
11ac-VHT80	MCS0	106	5530	-1.82	-1.73	-1.43	-1.06	93.66	4.81	≤ 10.88	Pass
11ac-VHT80	MCS0	122	5610	0.59	0.77	0.92	0.45	93.66	6.99	≤ 10.88	Pass
11ac-VHT80	MCS0	138	5690	0.70	0.84	0.91	0.24	93.66	6.99	≤ 10.88	Pass
11ac-VHT160	MCS0	50	5250	-6.14	-6.38	-6.24	-6.51	89.17	0.20	≤ 10.81	Pass
11ac-VHT160	MCS0	114	5570	-4.80	-4.84	-4.42	-4.96	89.17	1.77	≤ 10.88	Pass
11ax-HE20	MCS0	36	5180	6.83	7.15	7.22	6.40	97.50	13.04	≤ 16.81	Pass
11ax-HE20	MCS0	44	5220	10.28	10.55	10.57	9.58	97.50	16.39	≤ 16.81	Pass
11ax-HE20	MCS0	48	5240	10.55	10.89	10.67	9.51	97.50	16.57	≤ 16.81	Pass
11ax-HE20	MCS0	52	5260	4.25	4.38	4.37	4.24	97.50	10.44	≤ 10.81	Pass
11ax-HE20	MCS0	60	5300	4.42	4.51	4.26	4.36	97.50	10.52	≤ 10.81	Pass
11ax-HE20	MCS0	64	5320	4.49	4.58	4.65	4.51	97.50	10.69	≤ 10.81	Pass
11ax-HE20	MCS0	100	5500	4.25	4.23	4.43	4.39	97.50	10.46	≤ 10.88	Pass
11ax-HE20	MCS0	116	5580	4.46	4.38	4.47	4.26	97.50	10.52	≤ 10.88	Pass
11ax-HE20	MCS0	120	5600	4.09	4.43	4.89	4.28	97.50	10.56	≤ 10.88	Pass
11ax-HE20	MCS0	140	5700	2.51	2.89	3.18	2.98	97.50	9.03	≤ 10.88	Pass
11ax-HE20	MCS0	144	5720	4.31	4.57	4.85	4.50	97.50	10.69	≤ 10.88	Pass

Test Mode	Data Rate/MCS	Ch. No.	Freq. (MHz)	Ant 0PSD (dBm/MHz)	Ant 1 PSD (dBm/MHz)	Ant 2 PSD (dBm/MHz)	Ant 3 PSD (dBm/MHz)	Duty Cycle (%)	Total PSD (dBm/MHz)	PSD Limit (dBm/MHz)	Result
11ax-HE40	MCS0	38	5190	0.52	0.74	0.37	0.30	95.85	6.69	≤ 16.81	Pass
11ax-HE40	MCS0	46	5230	8.38	8.87	9.05	7.92	95.85	14.78	≤ 16.81	Pass
11ax-HE40	MCS0	54	5270	3.46	3.49	3.50	3.25	95.85	9.63	≤ 10.81	Pass
11ax-HE40	MCS0	62	5310	1.91	1.99	2.25	1.94	95.85	8.23	≤ 10.81	Pass
11ax-HE40	MCS0	102	5510	2.21	1.96	1.89	1.73	95.85	8.16	≤ 10.88	Pass
11ax-HE40	MCS0	110	5550	3.64	3.60	3.52	2.87	95.85	9.62	≤ 10.88	Pass
11ax-HE40	MCS0	118	5590	3.61	3.19	3.47	2.65	95.85	9.45	≤ 10.88	Pass
11ax-HE40	MCS0	134	5670	3.35	3.93	3.29	3.43	95.85	9.71	≤ 10.88	Pass
11ax-HE40	MCS0	142	5710	3.41	3.82	3.75	3.89	95.85	9.93	≤ 10.88	Pass
11ax-HE80	MCS0	42	5210	-2.74	-2.97	-3.01	-2.89	92.45	3.46	≤ 16.81	Pass
11ax-HE80	MCS0	58	5290	-1.90	-1.10	-1.33	-1.44	92.45	4.93	≤ 10.81	Pass
11ax-HE80	MCS0	106	5530	-0.67	-1.14	-0.69	-1.02	92.45	5.49	≤ 10.88	Pass
11ax-HE80	MCS0	122	5610	0.91	0.50	1.10	0.52	92.45	7.13	≤ 10.88	Pass
11ax-HE80	MCS0	138	5690	0.67	0.71	0.80	0.34	92.45	6.99	≤ 10.88	Pass
11ax-HE160	MCS0	50	5250	-6.50	-6.08	-6.21	-6.19	88.20	0.32	≤ 10.81	Pass
11ax-HE160	MCS0	114	5570	-4.77	-4.72	-4.35	-4.81	88.20	1.91	≤ 10.88	Pass

Note 1:

When EUT duty cycle < 98%, the total PSD (dBm/MHz) = $10 \cdot \log \{10^{(\text{Ant 0 AVGPSD}/10)} + 10^{(\text{Ant 1 AVGPSD}/10)} + 10^{(\text{Ant 2 AVGPSD}/10)} + 10^{(\text{Ant 3 AVGPSD}/10)}\} + 10 \cdot \log (1/\text{Duty cycle})$.

Note 2: PSD Limit Calculation as below:

For 5150-5250MHz: PSD Limit = 17 - (6.19 - 6) = 16.81dBm/MHz;

For 5250-5350MHz: PSD Limit = 11 - (6.19 - 6) = 10.81dBm/MHz;

For 5470-5725MHz: PSD Limit = 11 - (6.12 - 6) = 10.88dBm/MHz;

Test Mode	Data Rate/ MCS	Ch. No.	Freq. (MHz)	Ant 0 PSD (dBm/ 510kHz)	Ant 1 PSD (dBm/ 510kHz)	Ant 2 PSD (dBm/ 510kHz)	Ant 3 PSD (dBm/ 510kHz)	Duty Cycle (%)	Total PSD (dBm/ 510kHz)	PSD Limit (dBm/ 500kHz)	Result
For NII-3 Band:											
11a	6Mbps	149	5745	8.89	8.70	8.82	8.72	94.93	15.03	≤ 29.37	Pass
11a	6Mbps	157	5785	8.36	8.71	8.84	9.66	94.93	15.17	≤ 29.37	Pass
11a	6Mbps	165	5825	8.76	8.54	8.91	8.63	94.93	14.96	≤ 29.37	Pass
11ac-VHT20	MCS0	149	5745	8.79	8.84	8.87	9.33	97.86	15.08	≤ 29.37	Pass
11ac-VHT20	MCS0	157	5785	8.50	8.26	8.50	8.06	97.86	14.45	≤ 29.37	Pass
11ac-VHT20	MCS0	165	5825	8.39	8.84	8.82	9.66	97.86	15.07	≤ 29.37	Pass
11ac-VHT40	MCS0	151	5755	5.53	5.75	6.06	5.63	96.72	11.91	≤ 29.37	Pass
11ac-VHT40	MCS0	159	5795	5.68	5.58	6.39	5.57	96.72	11.98	≤ 29.37	Pass
11ac-VHT80	MCS0	155	5775	0.22	0.37	0.18	-0.34	93.66	6.42	≤ 29.37	Pass
11ax-HE20	MCS0	149	5745	8.55	8.53	9.15	9.68	97.50	15.13	≤ 29.37	Pass
11ax-HE20	MCS0	157	5785	8.40	8.09	8.70	7.57	97.50	14.34	≤ 29.37	Pass
11ax-HE20	MCS0	165	5825	8.50	8.43	8.82	9.71	97.50	15.03	≤ 29.37	Pass
11ax-HE40	MCS0	151	5755	5.60	5.61	6.24	5.23	95.85	11.89	≤ 29.37	Pass
11ax-HE40	MCS0	159	5795	5.38	5.83	6.01	5.63	95.85	11.92	≤ 29.37	Pass
11ax-HE80	MCS0	155	5775	0.56	0.76	0.10	0.06	92.45	6.74	≤ 29.37	Pass

Note 1:

When EUT duty cycle < 98%, the total PSD (dBm/510kHz) = $10 \cdot \log \{10^{(\text{Ant 0 AVGPSD}/10)} + 10^{(\text{Ant 1 AVGPSD}/10)} + 10^{(\text{Ant 2 AVGPSD}/10)} + 10^{(\text{Ant 3 AVGPSD}/10)}\} + 10 \cdot \log (1/\text{Duty cycle})$.

Note 2: PSD Limit Calculation as below:

For 5725-5850MHz: PSD Limit = $30 - (6.63 - 6) = 29.37\text{dBm/MHz}$;

802.11a Power Spectral Density - Ant 0

Channel 36 (5180MHz)

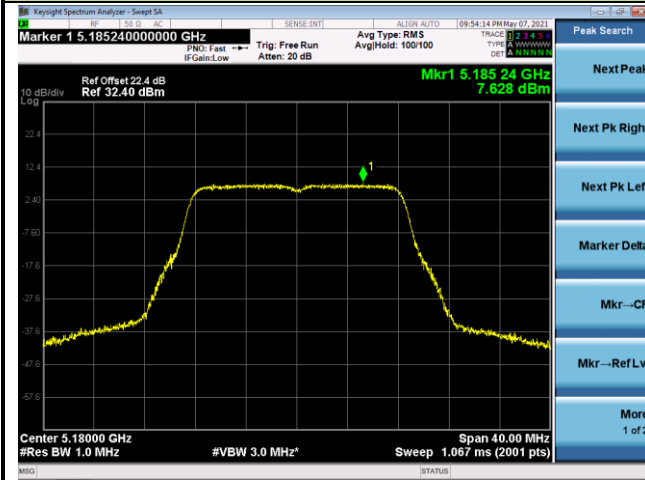

Channel 44 (5220MHz)

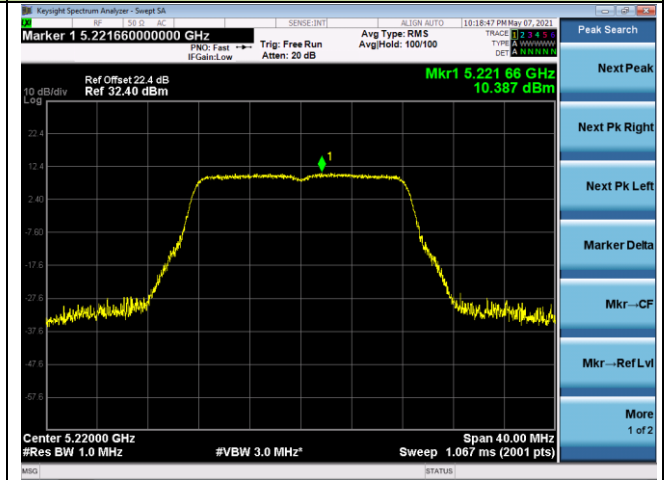

Channel 48 (5240MHz)

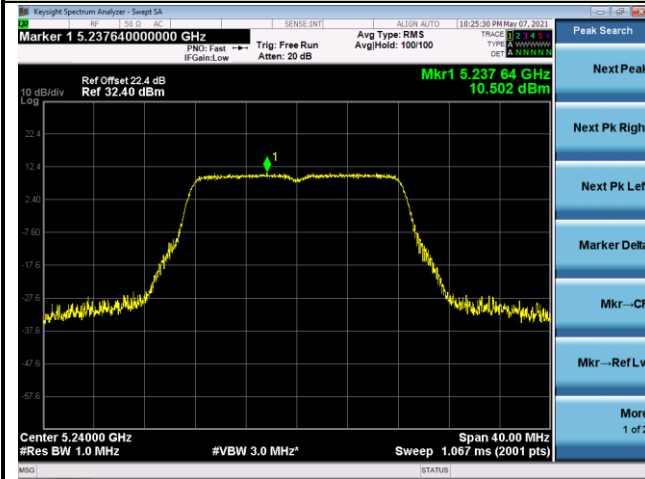

Channel 52 (5260MHz)

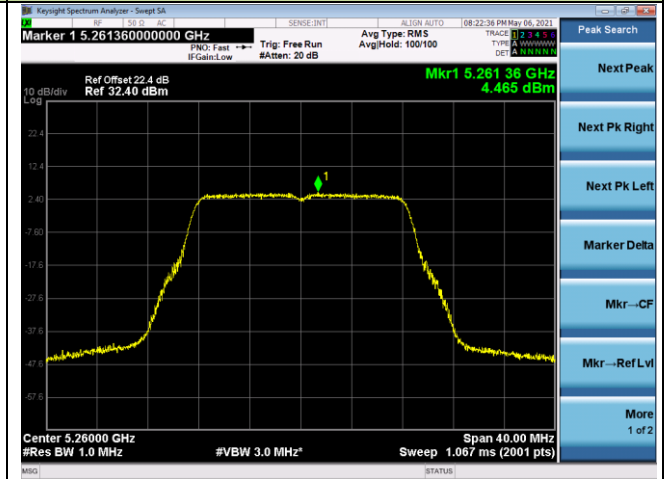

Channel 60 (5300MHz)

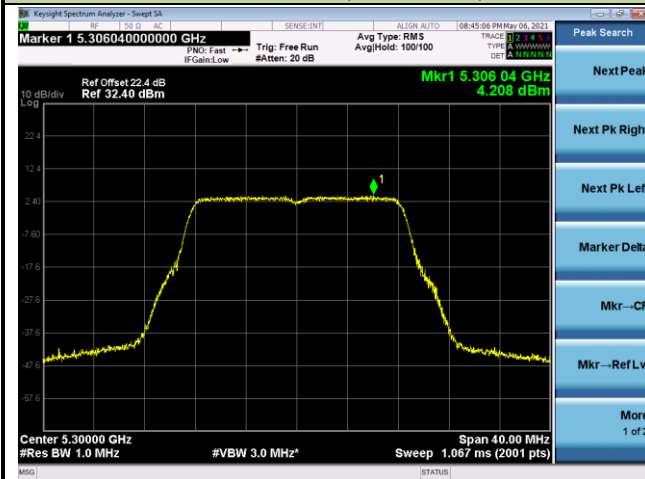

Channel 64 (5320MHz)

