

**BLUETOOTH/WI-FI WIRELESS STEREO SMART SPEAKER
WITH CHROMECAST BUILT-IN**

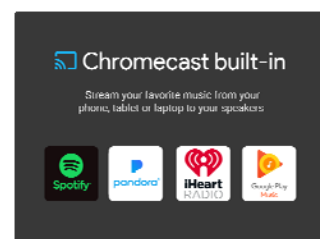

**Model: JSB-1000
USER MANUAL**



**PLEASE READ THIS USER MANUAL COMPLETELY BEFORE OPERATING THIS UNIT AND
RETAIN THIS BOOKLET FOR FUTURE REFERENCE.**

IMPORTANT SAFETY INSTRUCTIONS

When used in the directed manner, this unit has been designed and manufactured to ensure your personal safety. However, improper use can result in potential electrical shock or fire hazards. Please read all safety and operating instructions carefully before installation and use, and keep these instructions handy for future reference. Take special note of all warnings listed in these instructions and on the unit.

1. Read these instructions – All the safety and operating instructions should be read before the appliance is operated.
2. Keep these instructions – The safety and operating instructions should be kept for future reference.
3. Heed all warnings – All warnings on the appliance and in the operating instructions should be adhered to.
4. Follow all instructions – All operation and use instructions should be followed.
5. Do not use this apparatus near water – The appliance should not be used near water; for example, near a bath tub, washbowl, kitchen sink, laundry tub, in a wet basement, or near a swimming pool.
6. Clean only with dry cloth – The appliance should be cleaned only as recommended by the manufacturer.
7. Do not block any ventilation openings. Install in accordance with the manufacturer's instructions. The appliance should be situated so that its location or position does not interfere with its proper ventilation. For example, the appliance should not be situated on a bed, sofa, rug, or similar surface that may block the ventilation openings; or placed in a built-in installation, such as a bookcase or cabinet that may impede the flow of air through the ventilation openings.
8. Do not install near any heat sources such as radiators, heat registers, stoves, or other apparatus (including amplifiers) that produce heat.
9. AC adaptor is used as disconnect device and it should remain readily operable during intended use. In order to disconnect the apparatus from the mains completely, the AC adaptor should be disconnected from the mains socket outlet completely.
10. Only use attachments / accessories specified by the manufacturer.
11. Use only with a cart, stand, tripod, bracket, or table specified by the manufacturer, or sold with the apparatus. When a cart is used, use caution when moving the cart/apparatus combination to avoid injury from tip-over. 
12. Unplug this apparatus during lightning storms or when unused for long periods of time.
13. Refer all servicing to qualified service personnel. Servicing is required when the apparatus has been damaged in any way, such as power-supply cord or plug is damaged, liquid has been spilled or objects have fallen into the apparatus, the apparatus has been exposed to rain or moisture, does not operate normally, or has been dropped.
14. This appliance shall not be exposed to dripping or splashing water and that no object filled with liquids such as vases shall be placed on the apparatus.
15. Power Sources – The appliance should be connected to a power supply only of the type described in the operating instructions or as marked on the appliance. Do not overload wall outlet.

16. Battery shall not be exposed to excessive heat such as sunshine, fire or the like
17. Danger of explosion if battery is incorrectly replaced. Replace only with the same or equivalent type.
18. Do not attempt to dismantle, open or repair this product yourself. If a fault occurs, seek advice from your local qualified service technician or contact the distributor via the telephone number at the back of this instruction manual.
19. Caution marking and nameplate are located on the bottom of product.

IMPORTANT NOTE

Avoid installing the unit in locations described below:

- Places exposed to direct sunlight or close to heat radiating appliances such as electric heaters.
- Places subject to constant vibration.
- Dusty, humid or moist places.
- Sources of electrical noise such as fluorescent lamps or motors.
- In case of malfunction due to electrostatic discharge, the apparatus has to be reset by disconnecting it from mains supply, wait at least for 60 seconds before reconnect the AC power cord.

COMPLIANCE WITH FCC REGULATIONS

This device complies with Part 15 of the FCC Rules. Operation is subject to the following two conditions:

- (1) this device may not cause harmful interference, and
- (2) this device must accept any interference received, including interference that may cause undesired operation.

NOTE: This equipment complies with FCC RF radiation exposure limits set forth for an uncontrolled environment. This equipment should be installed and operated with a minimum distance of 20 centimeters between the radiator and your body.

This equipment has been tested and found to comply with the limits for a Class B digital device, pursuant to Part 15 of the FCC Rules. These limits are designed to provide reasonable protection against harmful interference in a residential installation. This equipment generates, uses and can radiate radio frequency energy and, if not installed and used in accordance with the instructions, may cause harmful interference to radio communications. However, there is no guarantee that interference will not occur in a particular installation. If this equipment does cause harmful interference to radio or television reception, which can be determined by turning the equipment off and on, the user is encouraged to try to correct the interference by one or more of the following measures:

- Reorient or relocate the receiving antenna.
- Increase the separation between the equipment and receiver.
- Connect the equipment into an outlet on a circuit different from that to which the receiver is connected.
- Consult the dealer or an experienced radio/TV technician for help.

CAUTION: Changes or modifications not expressly approved by the party responsible for compliance could void the user's authority to operate the equipment.

Protect Your Furniture

This product is equipped with non-skid rubber 'feet' to prevent the product from moving when you operate the controls. These 'feet' are made from non-migrating rubber material specially formulated to avoid leaving any marks or stains on your furniture. However certain types of oil based furniture polishes, wood preservatives, or cleaning sprays may cause the rubber 'feet' to soften, and leave marks or a rubber residue on the furniture. To prevent any damage to your furniture we strongly recommend that you purchase small self-adhesive felt pads, available at hardware stores and home improvement centers everywhere, and apply these pads to the bottom of the rubber 'feet' before you place the product on fine wooden furniture.

DEAR JENSEN® CUSTOMER

Selecting fine audio equipment such as the unit you've just purchased is only the start of your musical enjoyment. Now it's time to consider how you can maximize the fun and excitement your equipment offers. This manufacturer and the Electronic Industries Association's Consumer Electronics Group want you to get the most out of your equipment by playing it at a safe level. One that lets the sound come through loud and clear without annoying blaring or distortion and, most importantly, without affecting your sensitive hearing.

Sound can be deceiving. Over time your hearing "comfort level" adapts to higher volumes of sound. So what sounds "normal" can actually be loud and harmful to your hearing. Guard against this by setting your equipment at a safe level BEFORE your hearing adapts.

To establish a safe level:

- Start your volume control at a low setting.
- Slowly increase the sound until you can hear it comfortably and clearly, and without distortion.

Once you have established a comfortable sound level:

- Set the dial and leave it there.

Taking a minute to do this now will help to prevent hearing damage or loss in the future. After all, we want you listening for a lifetime.

We Want You Listening For a Lifetime

Used wisely, your new sound equipment will provide a lifetime of fun and enjoyment. Since hearing damage from loud noise is often undetectable until it is too late, this manufacturer and the Electronic Industries Association's Consumer Electronics Group recommend you avoid prolonged exposure to excessive noise.

Customer's Record:

The serial number of this product is found on its back cover. You should note the serial number of this unit in the space provided as a permanent record of your purchase to aid in identification in the event of theft or loss.

Model Number: JSB-1000

Serial Number: _____

ACCESSORIES

- 1 x AC Adaptor
- 1 x Stereo Audio Connection Cable with 3.5mm stereo plugs
- 1 x User Manual

LOCATION OF CONTROLS

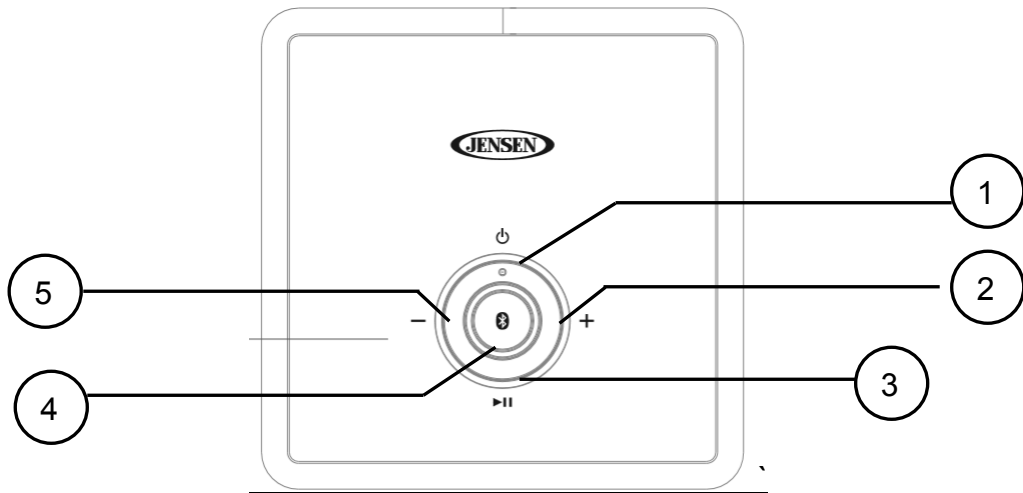

MAIN UNIT

Top View

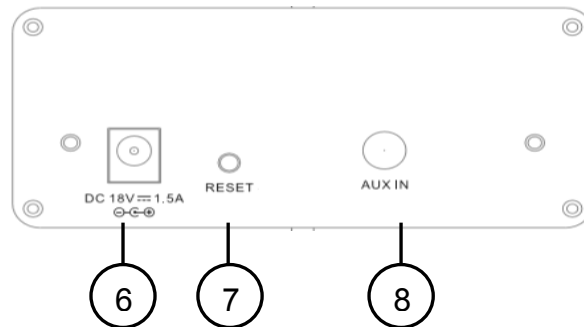

Back View



1. POWER ON/STANDBY  BUTTON, MODE INDICATOR LED
2. VOLUME + BUTTON
3. WI-FI STREAM/BLUETOOTH PLAY/PAUSE  BUTTON
4. BLUETOOTH MODE  /PAIR BUTTON
5. VOLUME - BUTTON
6. DC IN JACK
7. SPEAKER RESET/RECOVERY BUTTON
8. AUX IN JACK

GETTING STARTED

DOWNLOADING THE GOOGLE HOME APP

Go to the iTunes App Store (for iOS devices) or to Google Play (for Android devices) to download the Google Home app to the device you want to connect (smartphone, tablet, etc.).

CONNECTING THE AC POWER

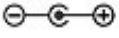
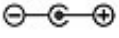
This unit operates using the included AC adaptor with 18V  1.5A (center-positive ) output, and is compatible with standard 120V~ 60Hz AC household power

1. Insert the the DC Plug of the AC Adaptor into the DC IN jack on the back of the unit. Plug the AC Adaptor into a standard 120V~ 60Hz AC wall outlet.
2. The unit will initialize when first plugged in. The initialization process could take up to 60 seconds to complete, so please wait for this process to finish before proceeding. The LED will light solid red for several seconds then changes to flashing white for several seconds while the unit is initializing. The LED may turn on and off during the initialization process, this is normal. The LED will be flashing White when the initialization is completed. The unit is now in setup Mode.

NOTE: 1.) The initialization process may take up to 60 seconds or longer when first connected. This process is normal and only occurs when first plugged in.

2.) If the unit has been setup to connect your Wi-Fi network successfully, the LED will be solid Red after booting in about 60 seconds. The unit is now in Standby mode.

INITIALIZATION

There is a multicolor LED indicator on the top panel. The operation mode is indicated by different color of the LED. The type of activity is indicated by whether the LED is on, flashing or its brightness:



Mode LED color	Solid on (Bright)	Solid on (Dim)	Pulse Effect (Bright & Dim)	Slow Flashing	Fast Flashing
Red	booting	Standby Mode/ Ready for Cast	---	---	Error
White	---	---	Connecting to Network	Network set up mode	Error
Green	Wi-Fi audio streaming Mode	Wi-Fi mode (No playback)	Buffering	---	---

Blue	Bluetooth Mode	---	No Bluetooth playback	Bluetooth Discoverable (Pairing mode)	
Yellow	AUX Mode (playing)	Aux Mode (No playback)	---	---	---
Orange	----	---	Update in process	Recovery Mode (User have to unplug & reconnect the power cable for reboot)	Error

Note:

A rapid flashing LED indicates an error. The device will automatically attempt to resolve the issue.

SETTING UP THE JSB-1000 ON A NETWORK

1. Make sure the device you want to connect (smartphone, tablet, etc.) is connected to a Wi-Fi network. The same Wi-Fi network will also be used for pairing the JSB-1000 with the Google Home app.
2. Make sure that Bluetooth is also enabled on your device (smartphone, tablet, etc.). During the set-up process the Google Home app will access your device (smartphone, tablet, etc.) using Bluetooth.
3. With the JSB-1000 in Standby Mode, open the Google Home app  and select the Devices icon  . A new screen will open showing available devices and the JSB-1000 will show as “Needs Setup.”

IMPORTANT: It may take up to a minute for the JSB-1000 to appear as an available device in the Google Home window, so do not select “Add New Device” in the app.

4. Follow the instructions in the Google Home app to complete the setup. The setup process may take several minutes. It’s normal for the LED indicator on the JSB-1000 to change colors or turn off for several seconds during the set-up process.

5. After the setup is complete, the LED Indicator will be solid Red (Standby mode), indicating the speaker is ready to stream. Refer to the “Using Chromecast built-in” section below for instructions on how to use Chromecast built-in.

Note: If you are setting up multiple speakers in the Google Home app, make sure the other speakers are turned off when setting up a new speaker.

USING CHROMECAST BUILT-IN

The JSB-1000 comes with Chromecast built-in. It lets you stream your favorite music from your phone, tablet or laptop right to your speakers. Easily control the JSB-1000 with apps you already know and love from your iPhone, iPad, Android phone or tablet, Mac or Windows laptop, or Chromebook.

1. Once you’ve completed setting up the JSB-1000 in the Google Home app, tap the Cast button  in any Chromecast-enabled app and select the JSB-1000 from the device menu.

NOTE: Consult the Google Home app for a list of apps that are Chromecast-enabled.

2. Audio will stream from the Chromecast-enabled app to JSB-1000 over your home Wi-Fi network. The LED Indicator is lit solid Green to indicate the unit is in Wi-Fi mode. When audio is streaming, the WI-FI STATUS LED INDICATOR will be solid green.
3. Use the VOLUME + BUTTON to increase the volume.
4. Use the VOLUME – BUTTON to decrease the volume.

STREAMING TO MULTIPLE SPEAKERS WITH CHROMECAST BUILT-IN

If you have multiple speakers set-up in the Google Home app, they can be grouped together so they all stream the same audio content.

1. Select the JSB-1000 from the Google Home app Devices List by clicking on the Devices icon .
2. Tap in the upper right corner of the JSB-1000 device window in the Google Home app and select “Create Group.”
3. Select at least two speakers (box will be checked once selected) from the list for the group and enter a name for the group.
4. The group will appear as an available connection when the Cast button is tapped in Chromecast-enabled apps.
5. Access the speaker group in the Google Home app to control play/pause or control the volume (if available in supported apps) of each speaker.

SPOTIFY CONNECT

How to use Connect

You'll need Spotify Premium to use Connect, see details on the included insert.

1. Add your new device to the same Wi-Fi network as your phone, tablet or PC (see product user instructions for details).
 2. Open the Spotify app on your phone, tablet or PC, and play any song.
 3. If you're using the app on a phone - tap the song image in the bottom left of the screen. For tablet and PC move to step 4.
 4. Tap the Connect icon
 5. Pick your device from the list. If you can't see it, just check it's connected to the same Wi-Fi network as your phone, tablet or PC.
- All done! Happy listening.

Licenses

The Spotify Software is subject to third party licenses found here:
www.spotify.com/connect/third-party-licenses.



BLUETOOTH OPERATION

PAIRING (LINKING) A BLUETOOTH ENABLED CELL PHONE OR OTHER BLUETOOTH ENABLED DEVICE to the JSB-1000

1. With the JSB-1000 in Stand-by Mode, tap the center Bluetooth  button to select Bluetooth mode. The Mode Indicator LED turns blue and will be flashing. The JSB-1000 is now ready to pair (link) with your Bluetooth device.
2. Turn on the Bluetooth feature of your cell phone and turn down the volume to avoid sudden loud sound bursts from the speaker. Enable the search or scan feature to find the JSB-1000 [xx.xx].
Note: [xx.xx] is the last 4 digits of speaker Mac address. If you have more than 1 JSB-1000 within range, make sure you are connecting to the appropriate speaker.
3. Select "JSBW-1000" from the device list when it appears on your device screen. If required, enter the pass code "0000" to pair (link) the JSB-1000 with your cell phone.
4. After successfully pairing (linking) your cell phone with the JSB-1000, the Mode Indicator LED stops flashing and remains lit blue. You can now play music from your cell phone or Bluetooth device wirelessly to the JSB-1000.

Note: If you want to connect the JSB-1000 to another cell phone after pairing successfully, then you need to turn off the Bluetooth on the paired cell phone first if it is in range before going through the above steps. Otherwise, the JSB-1000 will automatically reconnect to the previously linked cell

phone or device. Then press and hold the Bluetooth  button to put the JSB-1000 into Bluetooth pairing mode, the LED Indicator will be flashing Blue.

5. Press the VOLUME +/- button to adjust the volume level.
6. Press the PLAY/PAUSE  button to pause or resume playback.
7. To turn off the JSB-1000 Bluetooth, press and hold the /STANDBY button on main unit for 2 seconds to turn the unit to standby mode. Mode Indicator LED turns red. Don't forget to also turn off the Bluetooth feature on your cell phone or Bluetooth device.

Notes:

- 1.) Refer to manual of your cell phone or other Bluetooth enabled device for Bluetooth operation, since it may vary from model to model.
- 2.) If your Bluetooth enabled device does not support A2DP, it will not play the music through the speaker, even after it's paired (linked).
- 3.) If you are pairing (linking) your computer to the JSB-1000 using Bluetooth, you may need to set the JSB-1000 as your computer's default sound device.

Note: In power on mode, If no sound playback or paused by user for 15 minutes, unit will turn into standby mode automatically for power saving.

Re-linking to a cell phone or Bluetooth device

If your cell phone or Bluetooth device is already paired with the JSB-1000, but became unlinked at some point, even with both Bluetooth devices turned on. You can re-link them by:

1. Tap the /PAIR button to re-link your cell phone. The Mode Indicator LED will turn blue and flash while linking.
2. Select the JSB-1000 from the devices list on your cell phone for linking. The Mode Indicator LED stops flashing and remains lit blue if the JSB-1000 and your cell phone have been re-linked successfully.
3. You can also re-link the JSB-1000 by using Bluetooth operation of your cell phone. Please refer to operation manual of your cell phone for more information.

AUXILIARY INPUT

This unit provides an auxiliary audio signal input jack for connecting external audio devices like MP3 players, CD players and listen to them through the speakers of this unit.

1. Use an audio cable (included) with one 3.5 mm stereo plug on each end of the cable.
2. To select auxiliary audio input, plug one end into the Aux IN jack on the back of main unit, unit will turn into AUX mode automatically, Mode Indicator LED turns Yellow.

3. Plug the other end of the cable into the Line-out Jack or Headphone Jack of your external audio device.
4. Turn on the external audio device and the main unit.
5. The volume level can now be controlled through the main unit. Operate all other functions on the auxiliary device as usual.

NOTE:

- If you connect this unit to the Line-Out Jack of your external device then you only need to adjust the volume control of this unit. If you connected the Headphone Jack of your external device then you may need to adjust both the volume control of your external device and the volume control of this unit to find the most desirable volume setting.
- In power on mode, If no sound playback or paused by user for 15 minutes, unit will turn into standby mode automatically for power saving.
- Press and hold the POWER  button for 2 seconds to turning off the unit when you finish listening. Don't forget to switch off the power of your external device as well.

RESETTING THE JSB-1000

Power Cycle Reset

In case of malfunction due to electrostatic discharge, the apparatus has to be reset by disconnecting it from mains supply, wait at least for 60 seconds before reconnect the AC power cord.

If above steps cannot reset the unit, you may need to go through below process for factory reset.

Factory Reset

1. In Power ON mode, press and hold the RESET button for 5 seconds until MODE indicator LED change to Red.
2. Release the RESET button, unit will go into set up mode.
3. Waiting for about 2 minutes, MODE indicator stop changing color and flashing white.
4. Clear catches of apps in your samrtphone. Go through SETTING UP THE JSB-1000 ON A NETWORK section in the manual.

Note:

In Power ON mode, press and hold the RESET button longer than 5 seconds until MODE indicator LED change to Red then Orange may drive speaker into Recovery mode, Orange LED flashing. If this happen, go through power cycle reset procedures mentioned above and then factory reset procedures. Do not keep holding the RESET button if the LED turns Red from other color.

SOFTWARE UPDATES

The JSB-1000 internal software will automatically be updated when updates become available, and when the JSB-1000 is ON and connected to a Wi-Fi network. The LED Indicator will be flashing Orange during an update, and the JSB-1000 will auto-reboot automatically after the update is finished.

NOTE: Software updates can occur at any time, but they will normally be scheduled to occur in the middle of the night to avoid interfering with your listening.

CARE AND MAINTENANCE

1. Do not subject the unit to excessive force, shock, dust or extreme temperature.
2. Do not tamper the internal components of the unit.
3. Clean your unit with a dry cloth. Solvent or detergent should never be used.
4. Avoid leaving your unit in direct sunlight or in hot, humid or dusty places.
5. Keep your unit away from heating appliances and sources of electrical noise such as fluorescent lamps or motors.

CLEANING THE UNIT

- To prevent fire or shock hazard, disconnect your unit from the AC power source when cleaning.
- The finish on the unit may be cleaned with a dust cloth and cared for as other furniture, Use caution when cleaning and wiping the plastic parts.
- If the cabinet becomes dusty wipe it with a soft dry dust cloth. Do not use any wax or polish sprays on the cabinet.
- If the front panel becomes dirty or smudged with fingerprints it may be cleaned with a soft cloth slightly dampened with a mild soap and water solution. Never use abrasive cloths or polishes, as these will damage the finish of your unit.

CAUTION: Never allow any water or other liquids to get inside the unit while cleaning.

Note: This unit is not magnetically shielded and may cause color distortion on the screen of some TVs or video monitors. To avoid this, you may need to move the unit further away from the TV or monitor if unnatural color shifts or image distortion occurs.

TROUBLESHOOTING GUIDE

Should you experience difficulties in the use of this player please refer to the following chart or call 1-800-777-5331 for Product Service and Support.

Symptom	Possible Problem	Solution
The unit does not respond (no power)	The unit is disconnected from the AC outlet.	Reconnect to the AC outlet.
	The AC outlet has not power.	Try the unit on another outlet.
Unit is ON but there is low or no volume	The volume control has been turned all the way down.	Turn the Volume control to a higher output.
No Sound	Google Cast speaker is not in same WiFi network of your	Use the same WiFi network for speaker & your smartphone.

	smartphone.	
	Speaker is not set up for Google Cast.	Set up speaker by following the set up steps in the manual.
	You have not select casting to speaker.	Select speaker in your samrtphone screen.
	Bluetooth speaker is not linked with the cell phone.	Go through “Bluetooth Operations” process to link the speakers.
	Speaker placement out of range.	Relocate the speaker within Bluetooth operating range
Sound is distorted	Volume level is set too high.	Decrease the volume.
	Sound source is distorted.	If the external device original sound source is of poor quality, distortion and noise are easily noticed with high-power speakers. Try a different audio source such as a music CD . If you are using an external sound source like older generation of iPod, try reducing the output volume on the device itself. Also try turning bass boost OFF or change the EQ setting.
Unit gets warm after extended play at high volume	This is normal.	Turn the unit off for a period of time or lower volume.

SPECIFICATION

Power requirement:

Main Unit

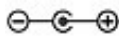
AC-DC Adaptor DC 18V, 1.5 A 



At Spectra, environmental and social responsibility is a core value of our business. We are dedicated to continuous implementation of responsible initiatives with an aim to conserve and maintain the environment through responsible recycling.

Please visit us at <http://www.spectraintl.com/green.htm> for more information on Spectra’s green initiatives or to find a recycler in your area.

The *Bluetooth*® word mark and logos are registered trademarks owned by Bluetooth SIG, Inc. and any use of such marks by Spectra Merchandising Intl, Inc. is under license. Other trademarks and trade names are those of their respective owners.

Chromecast is a trademark of Google Inc.

The Spotify software is subject to third party licenses found here: <https://developer.spotify.com/esdk-third-party-licenses/>

**90 DAY LIMITED WARRANTY AND SERVICE
VALID IN THE U.S.A. ONLY**

SPECTRA MERCHANDISING INTERNATIONAL, INC. warrants this unit to be free from defective materials or factory workmanship for a period of 90 days from the date of original customer purchase and provided the product is utilized within the U.S.A. This warranty is not assignable or transferable. Our obligation under this warranty is the repair or replacement of the defective unit or any part thereof, except batteries, when it is returned to the SPECTRA Service Department, accompanied by proof of the date of original consumer purchase, such as a duplicate copy of a sales receipt.

You must pay all shipping charges required to ship the product to SPECTRA for warranty service. If the product is repaired or replaced under warranty, the return charges will be at SPECTRA's expense. There are no other express warranties other than those stated herein.

This warranty is valid only in accordance with the conditions set forth below:

1. The warranty applies to the SPECTRA product only while:
 - a. It remains in the possession of the original purchaser and proof of purchase is demonstrated.
 - b. It has not been subjected to accident, misuse, abuse, improper service, usage outside the descriptions and warnings covered within the user manual or non-SPECTRA approved modifications.
 - c. Claims are made within the warranty period.
2. This warranty does not cover damage or equipment failure caused by electrical wiring not in compliance with electrical codes or SPECTRA user manual specifications, or failure to provide reasonable care and necessary maintenance as outlined in the user manual.
3. Warranty of all SPECTRA products applies to residential use only and is void when products are used in a nonresidential environment or installed outside the United States.

This warranty gives you specific legal rights, and you may also have other rights which vary from state to state. TO OBTAIN SERVICE please remove all batteries (if any) and pack the unit carefully and send it freight prepaid to SPECTRA at the address shown below. IF THE UNIT IS RETURNED WITHIN THE WARRANTY PERIOD shown above, please include a proof of purchase (dated cash register receipt) so that we may establish your eligibility for warranty service and repair of the unit without cost. Also include a note with a description explaining how the unit is defective. A customer service representative may need to contact you regarding the status of your repair, so please include your name, address, phone number and email address to expedite the process.

IF THE UNIT IS OUTSIDE THE WARRANTY PERIOD, please include a check for **\$40.00** to cover the cost of repair, handling and return postage. All out of warranty returns must be sent prepaid.

It is recommended that you contact SPECTRA first at 1-800-777-5331 or by email at custserv@spectraintl.com for updated information on the unit requiring service. In some cases the model you have may be discontinued, and SPECTRA reserves the right to offer alternative options for repair or replacement.

SPECTRA MERCHANDISING INTERNATIONAL, INC.
4230 North Normandy Avenue,
Chicago, IL 60634, USA.
1-800-777-5331

To register your product, visit the link on the website below to enter your information.
<http://www.spectraintl.com/wform.htm>