

- A Short Range Magnetic Inductive Technology -

MG9030 includes the following Components:

A) Wireless **Headset** Unit / with Ni-MH Rechargeable **Battery Pack** (Fig.1 & Fig.2)

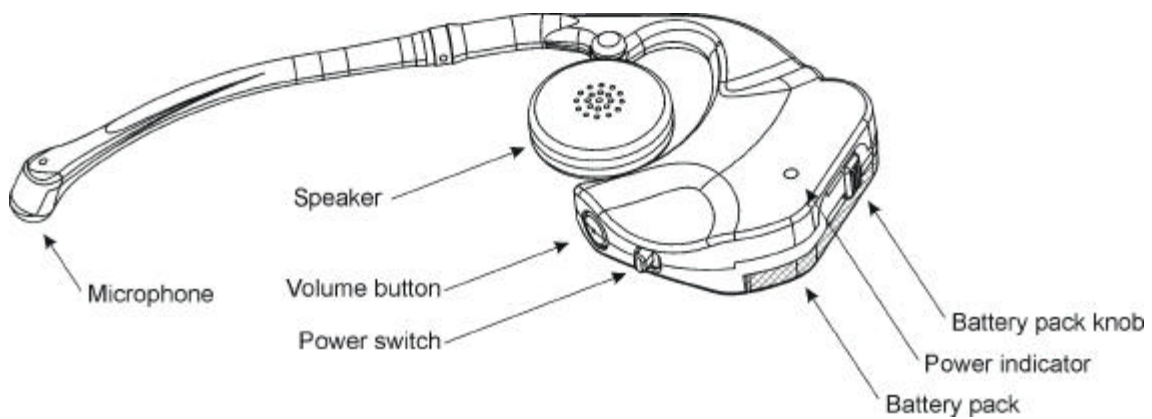

Fig.1

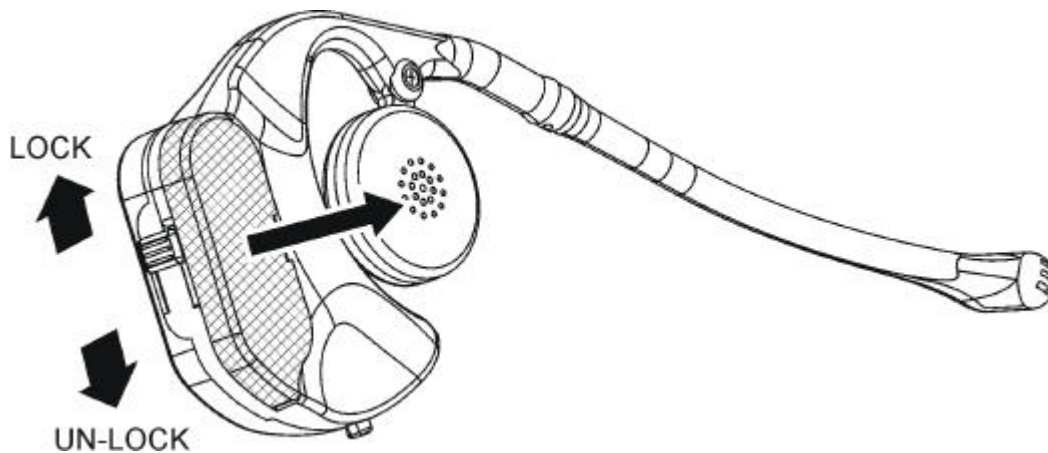

Fig.2

B) Base Unit / with Ni-MH Rechargeable Battery Pack (Fig.3 & Fig.4)

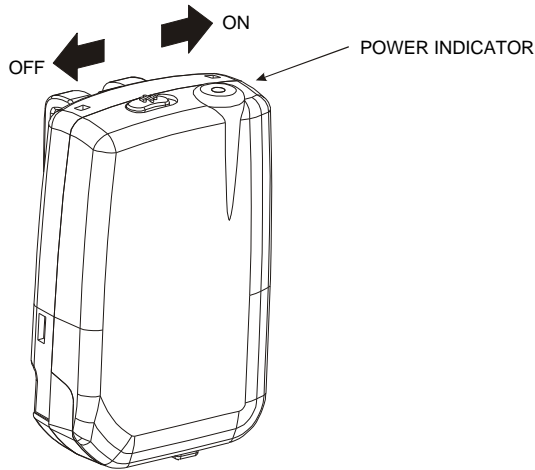

Fig.3

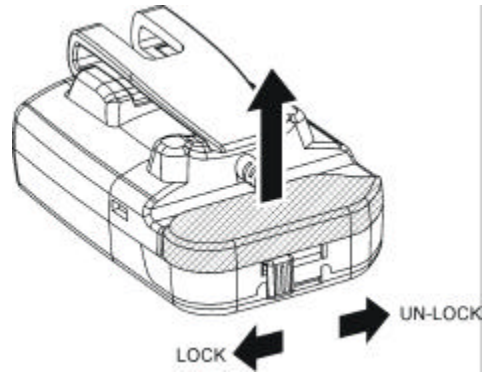

Fig.4

C) Battery charger / with a AC to DC adaptor

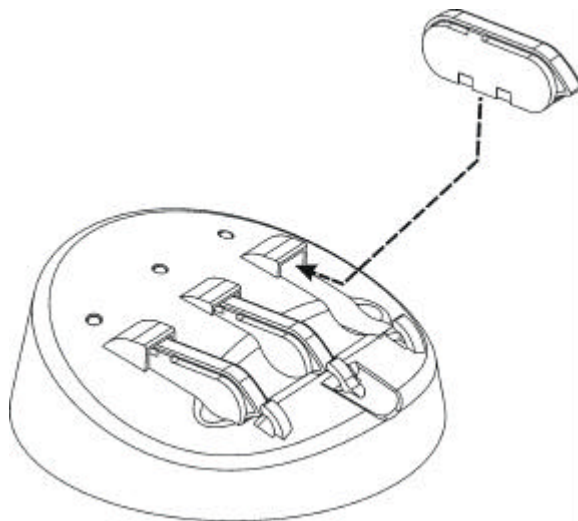

Fig. 5

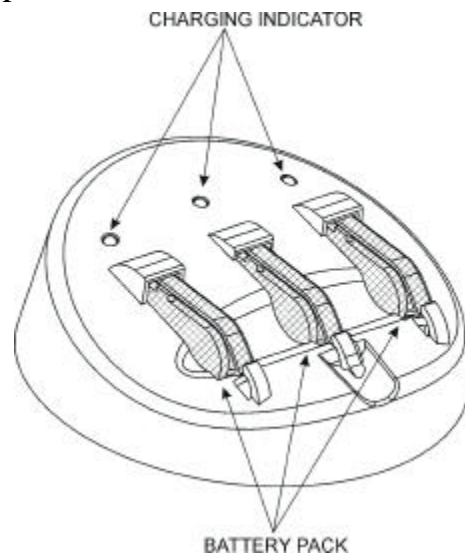

Fig. 6

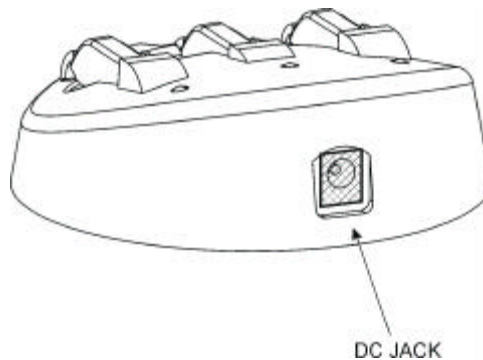
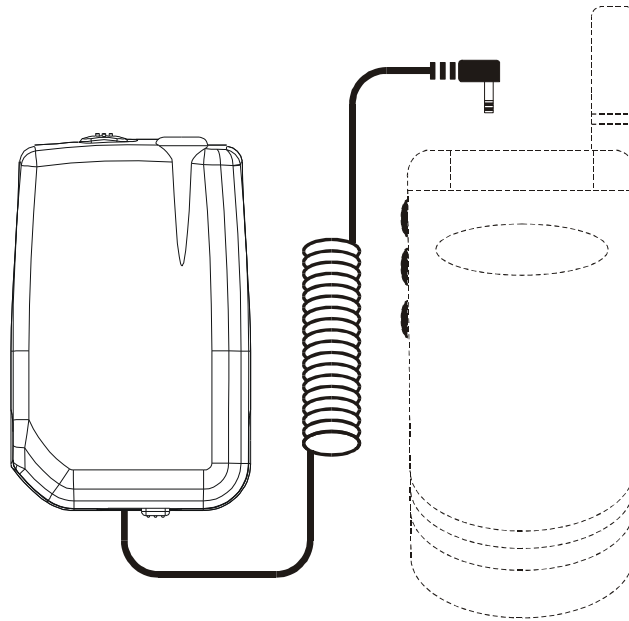

Fig. 7

How to use:

Step 1) Insert the Battery Pack into the **Base Unit** to power it up.

Step 2) Connect **Base Unit** to the audio receptacle on your cellular phone by the **cable** of the Base Unit. Adapter may be required for the connection. Consult your local distributor the suitable adapter for your phone.



Step 3) Set your cellular phone to “auto receive” mode (provided that your cellular phone has this feature) if you want to be totally hand free.

Step 4) Turn on the **headset** by the power switch as shown.

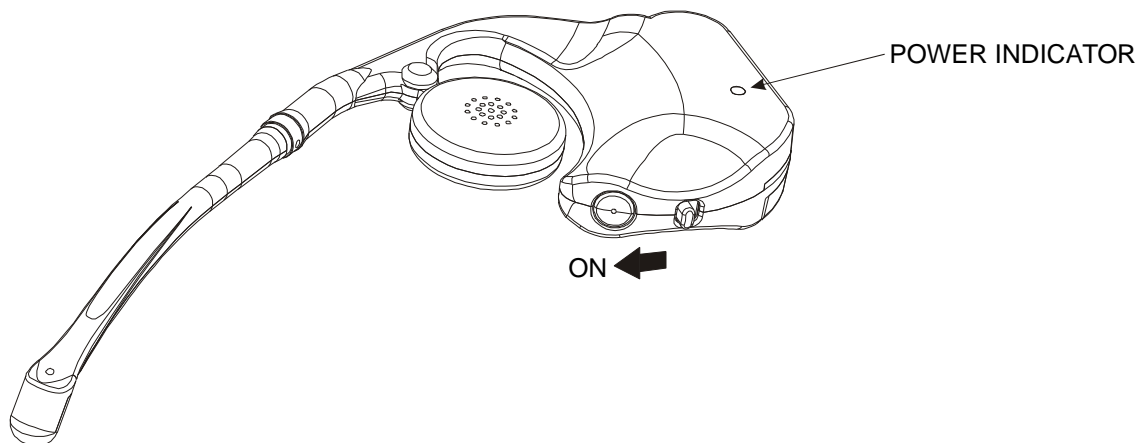

Step 5) Open the gap between the ear ride and the speaker and put the **headset** on your ear. (This headset is designed for both left and right ears)

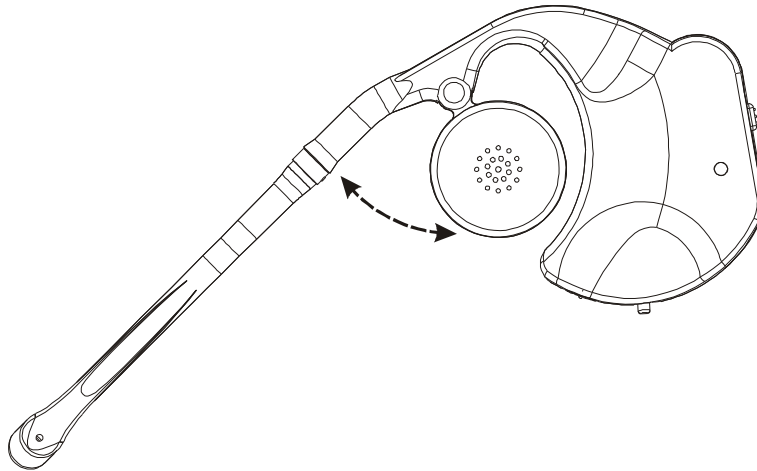

Step 6) Tighten the **headset** by moving the speaker back to the ear ride. Rotate the microphone tip to make it as closer to your month as possible.

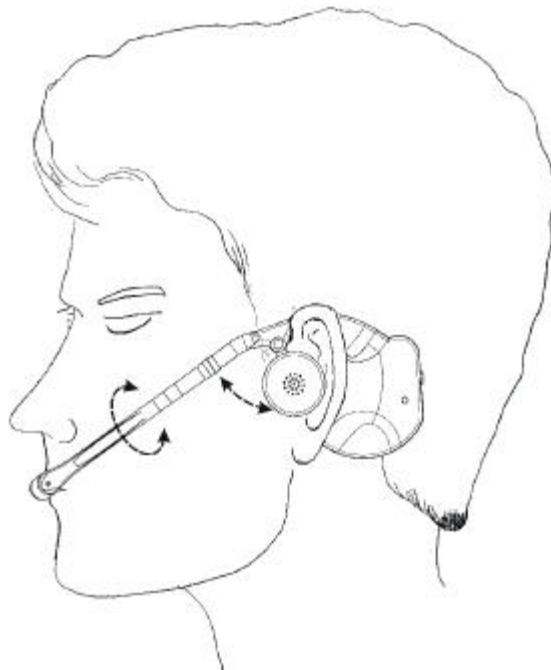

Step 7) Make a test call to a friend using your cellular phone. Dial tone should present if the key tone has been activated on your cellular phone.

Step 8) Adjust the speaker volume by pushing the four-step volume button to achieve the appropriate speaker volume. (You may need to adjust the volume again if the **Headset** has been switched off)

Troubleshooting:

If you do not hear a dial tone when you try to make a phone call.

1. Make sure your **Battery Pack** is fully charged and inserted in your **Headset** and **Base Unit**.
2. Confirm the Power Switches on both **Base Unit** and **Headset** are on the ON position.
3. Be sure that the green LEDs is ON for both **Base Unit** and **Headset** when you push the keypad.
4. Make sure that the **cable** is compatible with your cellular phones. For most of the cellular phones, "Headset" will display on the screen if the **cable** is connected correctly.
5. Confirm the volume of your cellular phone is set to the maximum level.
6. Try pushing the volume button on the **headset** to increase the audio level.

Battery Charging:

Step 1) Plug the AC to DC adaptor into the electric socket. Then connect the adaptor to the **Battery Charger** shown in Fig. 7.

Step 2) Insert the battery pack into the Charger (Fig.6). Three battery packs can be charged at the same time independently.

Step 3) The red LED on the Charger will be ON (Fig. 6) when the battery is being charged.

Step 4) After approximate 10 hours, the battery pack will be fully charged and the red LED will be OFF.

Step 5) Remove the battery pack from the Charger and insert it to the Base Unit or Headset for battery replacement. The charged battery will last for around 2.5 hours talk time or 150 hours in standby mode. It is recommended to put the discharged battery packs into the charger for overnight charging.

Important Note:

- 1) Effective Transmission Distance is about 1.5 Meters (~ 5 feet). If you exceed this distance, the **Headset** will mute the speaker output. If you stay out of range for more than 32 seconds, the headset will automatically switch to standby mode to save battery life. At that time, the LED on the headset will be blinking and the red LED on the **Base Unit** will be on, indicating the link is broken. To establish the link, simply move **Headset** closer the **Base Unit** and both green LEDs on the **Base Unit** and the **Headset** will be ON again.
- 2) When the **Base Unit** is off or in standby mode, the headset will also automatically switch to standby after 32 seconds.
- 3) Make sure no obstacle between the **Base Unit** and **Headset** to receive optimal sound quality.
- 4) Only need to turn off the **Base Unit** and **Headset** when you do not want to use your cellular phone for a long time.
- 5) Do not attempt to put on your **Headset** or change the battery while driving.
- 6) While the mobile phone network signal strength is very weak, your mobile phone radiation power will automatically increase, resulting in some “mosquito” noise at your headset. When this happens, try moving the mobile phone further away from the **Base Unit** or changing the orientation of your mobile phone to minimize the noise.
- 7) You may experience some interference from other electronic equipment (such as computer monitor). In this case, you can change the frequencies of the **Base Unit** and the **Headset** by the hidden switches as indicated below from channel 1 to 2 (or vice versa). Make sure that both switches are at the positions of same channel. If this does not help, try moving the Base Unit away from the equipment.

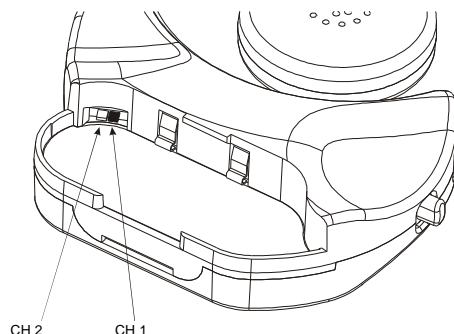
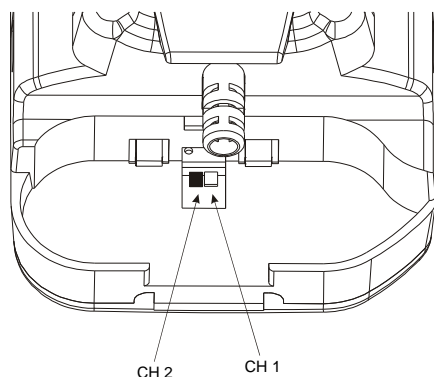

These devices comply with part 15 of the FCC rules. Operation is subjected to the following two conditions: 1) This device may not cause harmful interference and 2) This device must accept any interference received, including interference that may cause undesired operation.

Changes or modifications not expressly approved by the party responsible for compliance could void the users authority to operate the equipment.