

# Aclara®



---

## DCU Maintenance and Operation Technical Manual

Y20976 - TUM  
Revision D  
[www.Aclara.com](http://www.Aclara.com)



---

**Proprietary Notice**

This document contains information that is private to Aclara Technologies LLC, an Ohio limited liability company, and/or that is private to Aclara Meters LLC, a Delaware limited liability company (individually or collectively “Aclara”). This information may not be published, reproduced, or otherwise disseminated without the express written authorization of Aclara.

Any software or firmware described in this document is furnished under a license and may be used or copied only in accordance with the terms of such license.

**Disclaimer**

The information in this document is subject to change without notice and should not be construed as a commitment by Aclara. Aclara assumes no responsibility for any errors that may appear in this document.

No responsibility is assumed for the use or reliability of software on equipment that is not supplied by Aclara.

Metrum Cellular, STAR, Synergize, and TWACS are registered trademarks of Aclara Technologies LLC.

**Aclara Technologies LLC  
Confidential and Proprietary  
Copyright 2020-2021. All Rights Reserved.**



# Table of Contents

<b>Chapter 1: Product Specifications</b>	<b>1</b>
<b>Chapter 2: Warnings, Cautions, and Notes</b>	<b>3</b>
Supplier's Declaration of Conformity . . . . .	.3
47 CFR 2.1077 Compliance Information . . . . .	.3
FCC/IC Compliance . . . . .	.4
FCC/IC RF Exposure Guide . . . . .	.4
Field Calibration Procedure . . . . .	.5
Avertissements, mises en garde et remarques . . . . .	.5
Conformité FCC/IC . . . . .	.5
Guide d'exposition aux RF FCC/IC . . . . .	.6
Procédure de calibration sur place . . . . .	.6
Safety Guidelines . . . . .	.6
Shock Hazard Warning . . . . .	.6
Fall Hazard When Working at Elevation . . . . .	.7
Pole-Mount Installations . . . . .	.7
Required Grounding . . . . .	.7
RF Exposure Hazard . . . . .	.7
ESD Caution . . . . .	.8
Replacement Parts . . . . .	.8
Rooftop-Specific Hazards . . . . .	.8
Inspect Antenna Clearance . . . . .	.8
Support . . . . .	.9
Aclara Connect . . . . .	.9
Aclara University . . . . .	.9
Technical Support . . . . .	.9
Returning Product . . . . .	.9
<b>Chapter 3: Introduction</b>	<b>11</b>
AclaraONE™ Headend . . . . .	11
Endpoint Devices . . . . .	11
Data Collector Unit (DCU) . . . . .	12
Backhaul Options . . . . .	12
LTE . . . . .	12
Ethernet . . . . .	12
Fiber . . . . .	13
Failover Backhaul . . . . .	13
System Prerequisites . . . . .	13
Solar . . . . .	13
Transceiver Board Options . . . . .	13
Global Positioning System (GPS) . . . . .	14
Battery Protection . . . . .	14
DCU 2+ . . . . .	14
DCU 2 . . . . .	15
<b>Chapter 4: Commissioning</b>	<b>19</b>
Tools Required . . . . .	19

Connect to the Main Board . . . . .	19
Commission the DCU . . . . .	20
Installer Commands . . . . .	22
DCU Console Menu . . . . .	24
Global Commands . . . . .	25
Administrator Commands (for an LTE Backhaul) . . . . .	26
Alarm Menu . . . . .	27
Manufacturing Menu . . . . .	27
MTU Menu . . . . .	27
Transceiver Menu. . . . .	28
Records Menu . . . . .	28
Power Supply Debug Menu . . . . .	28
Transceiver Debug Menu . . . . .	29
Advanced Menu . . . . .	29
Global Navigation Satellite System (GNSS) Menu . . . . .	30
<b>Chapter 5: Maintenance</b>	<b>31</b>
Inspecting the Site . . . . .	31
Observe All Safety Precautions . . . . .	31
Survey the Site . . . . .	31
Inspect the Mounting . . . . .	31
Inspect the Lock . . . . .	32
Inspect the Battery . . . . .	32
Inspect the Earth Ground Resistance . . . . .	32
Colocation Assurance . . . . .	32
Antenna Clearance . . . . .	33
Label Inspection . . . . .	33
General Observations . . . . .	33
Servicing the DCU . . . . .	34
Tools & Equipment Required . . . . .	35
Routine Checks . . . . .	35
Repairs . . . . .	36
Repairing the DCU. . . . .	36
Replacing a Fuse . . . . .	36
Replacing the Battery . . . . .	36
Replacing the Cellular Antenna. . . . .	37
Replacing an RF Antenna. . . . .	37
Replacing a Solar Panel . . . . .	38
Replacing a Printed Circuit Board (PCB) . . . . .	39
Replacing a Main Board . . . . .	40
<b>Chapter 6: Troubleshooting</b>	<b>43</b>
AclaraONE . . . . .	43
Visual Check . . . . .	43
Troubleshooting . . . . .	44
DCU Main Processor Board . . . . .	44
Main Processor Board with Ethernet . . . . .	45
Main Processor Board without Ethernet . . . . .	46
Cellular Board . . . . .	47

---

Global Positioning System (GPS) Card . . . . .	48
Antenna . . . . .	49
Transceiver Board (T-Board) . . . . .	49
Power Supply Board . . . . .	50
Backplane . . . . .	51
<b>Appendix A: Testing the DCU</b>	<b>53</b>
DCU Antenna Pattern Test. . . . .	53
Baseline Data. . . . .	53
Field Data . . . . .	54
Interferer Test . . . . .	55
Calibrating the DCU's RSSI Measurement . . . . .	56
Testing the Coax and Antenna . . . . .	57
RF Sweeps . . . . .	57
Calibration. . . . .	57
Return Loss on the Coaxial Cable. . . . .	57
Distance to Fault (Coaxial Cable). . . . .	57
Coaxial Cable Insertion Loss . . . . .	57
Return Loss (Antenna System) . . . . .	58
Test Analysis . . . . .	58
Spectrum Analysis. . . . .	59
Measuring Earth Ground . . . . .	59
Testing the Backhaul . . . . .	59
Functional Testing. . . . .	59
Performance Testing. . . . .	60
<b>Appendix B: Local Menu "WALL" Command Information</b>	<b>61</b>
<b>Appendix C: DCU-Generated Headend Messages</b>	<b>73</b>





# PRODUCT SPECIFICATIONS

The following table summarizes the specifications of Aclara's DCU .

Input power for AC-powered units	120 VAC, single phase, 60 Hz, 1 A (maximum amperage)
Input power for DC-powered units	12-28VDC, 7 A (max)
AC powered DCU 2/2+ average power consumption	AC DCU 2 - 72 kWh/year AC DCU 2+ - 88 kWh/year
Timekeeping source	GPS
450 MHz band antenna port output power	+33 dBm (2W) (conducted)
Maximum 450 MHz band transmitter duty cycle	10% @ 25°C ambient
450 MHz band receiver sensitivity	The system shall provide a receive sensitivity (measured at antenna port) of less than -114 dBm to support a $10^{-5}$ BER
Frequency band	450 - 470 MHz
<i>Note: The DCU is configurable to operate in numerous specific 12.5 kHz channels within the 450-470 MHz band.</i>	
Transmission rate	4800 BAUD - provides 4800 bps when operated with 2GFSK modulation and 9600 bps with 4GFSK modulation
Antenna impedance	50 Ohm
Antenna gain	Long-range antenna (Laird) gain is 7.15 dBi; standard-range antenna (EM Wave) gain is 5 dBi
Altitude	Tested per MIL STD-810G to an altitude of 7000ft.
Operating temperature range	-40° to +85°C
Earthquake immunity	GR-63-CORE Seismic test - Zone 4
Power outage ride-through capability	3 days @ 25°C when batteries are fully charged
Weight of DCU chassis without battery	34 pounds
Weight of battery	38 pounds
IEEE1613 compliance	UL 60950-1; Safety Class 1 UL 61000-4-3 UL 61000-4-6, Class 1 Recovery (RF susceptibility)
Ethernet Connectivity	RJ45 connection 10/100 Mbps speed
Fiber Connectivity	Single mode 1300/1310nm wavelength SC with UPC polish connection 100 Mbps speed



**CHAPTER****2**

# WARNINGS, CAUTIONS, AND NOTES

Always consult and adhere to all local and national safety codes, regulations, and standards. WARNING, CAUTION and Note statements are used throughout this manual to emphasize important and critical information to help you ensure safety and prevent product damage. These statements are defined below.

**WARNING**

Indicates a potentially hazardous situation which, if not avoided, could result in death or serious physical injury.

**CAUTION**

Indicates a situation, which, if not avoided, could result in damage to equipment, damage to software, loss of data or invalid results.

**NOTE** Indicates important supplemental information.

## Supplier's Declaration of Conformity

### 47 CFR 2.1077 Compliance Information

Product Identifier: Aclara Data Collection Unit (DCU 2+)

Responsible Party - U.S. Contact Information

Aclara Technologies LLC

30400 Solon Road

Solon, Ohio 44139

Phone: 800-892-9008 Email: [aclarasupport@hubbell.com](mailto:aclarasupport@hubbell.com)

## FCC/IC Compliance

This equipment has been tested and found to comply with the limits for a Class B digital device, pursuant to part 15 of the FCC Rules. These limits are designed to provide reasonable protection against harmful interference in a residential installation. This equipment generates, uses, and can radiate radio frequency energy and, if not installed and used in accordance with the instructions, may cause harmful interference to radio communications. However, there is no guarantee that interference will not occur in a particular installation. If this equipment does cause harmful interference to radio or television reception, which can be determined by turning the equipment off and on, the user is encouraged to try to correct the interference by one or more of the following measures:

- Reposition or relocate the receiving antenna. (This would have to be done by an installer.)
- Increase the separation between the equipment and receiver.
- Connect the equipment into an outlet on a circuit different from that to which the receiver is connected.
- This device contains:  
Aclara RF Module, Model 101-9975T-SRFN  
FCC ID: LLB9975T IC: 4546A-9975T

The antenna must not have a gain greater than 7.15 dBi.

**CAUTION** Any changes or modification made to this device without the expressed, written approval of Aclara Technologies LLC may void the user's authority to operate this device.

## FCC/IC RF Exposure Guide

Aclara Technologies LLC low power RF devices and their antennas must be fixed-mounted on indoor or outdoor permanent structure(s) providing a separation distance of at least 1 meter from all persons during normal operation. This device is not designed to operate in conjunction with any other antennas or transmitters. No other operating instructions for satisfying RF exposure compliance are needed.

Holding the antenna in one's hands while it is transmitting, or standing near a transmitting antenna for a prolonged period of time, could result in RF exposure that exceeds FCC and Health Canada recommendations.

Once the DCU is powered up and operational, it will emit RF energy. Installers, technicians, and the public at large should keep a distance of 1 meter or more from the plane of the antenna.

This device has been tested for exposure of humans to RF energy. It satisfies OSHA, FCC, and Health Canada requirements provided it is installed in a manner described in this manual and operated in accordance with the user guide.

## Field Calibration Procedure

Aclara Technologies LLC low power RF devices have passed through extensive testing and calibration procedures while in the factory. Therefore, no additional calibration or adjustment is required in the field.

## Avertissements, mises en garde et remarques

Toujours consulter et respecter les codes, règlements et normes de sécurité locaux et nationaux. Des AVERTISSEMENTS, MISES EN GARDE et remarques sont utilisés tout au long de ce guide pour souligner l'information importante et critique qui vous aidera à assurer la sécurité et à prévenir les dommages au produit. Ces énoncés sont définis ci-dessous.

### **WARNING**

Indique une situation potentiellement dangereuse qui, si elle n'était pas évitée, pourrait entraîner la mort ou des blessures graves.

### **CAUTION**

indique une situation qui, si elle n'était pas évitée, pourrait entraîner des dommages à l'équipement, des dommages au logiciel, des pertes de données ou des résultats invalides.

**REMARQUE** indique des informations supplémentaires importantes.

## Conformité FCC/IC

Cet équipement a été testé et il est conforme aux limites pour un appareil numérique de Classe B, en vertu de l'article 15 des règlements de la FCC. Ces limites sont conçues pour offrir une protection raisonnable contre l'interférence nuisible dans une installation résidentielle. Cet équipement génère, utilise et peut émettre de l'énergie de fréquences radio et, s'il n'est pas installé ou utilisé conformément aux instructions, il peut causer une interférence nuisible aux communications radio. Il n'existe toutefois aucune garantie que de telles interférences ne se produiront pas dans une installation particulière. Si cet appareil cause des interférences nuisibles à la réception des signaux de radio ou de télévision, ce qui peut être détecté en mettant l'appareil sous et hors tension, l'utilisateur peut tenter de neutraliser l'interférence de l'une ou l'autre des façons suivantes :

- Réorienter ou repositionner l'antenne de réception.
- Augmenter la distance séparant l'équipement du récepteur.
- Brancher l'appareil dans une prise sur un circuit électrique différent de celui sur lequel le récepteur est branché.
- Consulter le fournisseur ou un technicien radio ou télévision expérimenté.

- Cet appareil contient: Module RF Aclara, Model 101-9975T-SRFN  
FCC ID: LLB9975T IC: 4546A-9975T

L'antenne ne doit pas avoir un gain supérieur à 7,15 dBi.

**MISE EN GARDE** Tout changement ou toute modification à cet appareil sans l'approbation écrite expresse d'Aclara Technologies LLC peut annuler l'autorisation de l'utilisateur d'utiliser cet appareil.

## **Guide d'exposition aux RF FCC/IC**

Les appareils RF à faible puissance Aclara Technologies LLC ainsi que leurs antennes doivent être montés de manière fixe sur des structures intérieures ou extérieures permanentes qui se trouvent à au moins 1 mètre des personnes pendant le fonctionnement normal. Cet appareil n'est pas conçu (et il n'a aucun branchement externe) pour être utilisé en association avec toute autre antenne ou tout transmetteur. Aucune autre instruction d'utilisation n'est requise pour assurer la conformité aux règles d'exposition aux RF.

## **Procédure de calibration sur place**

Les appareils RF à faible puissance Aclara Technologies LLC ont été soumis à des tests étendus et multi-tâches et à des procédures de calibration complexes en usine. Par conséquent, ils ne requièrent pas de calibration ni d'ajustement supplémentaire sur place.

## **Safety Guidelines**

Aclara makes a fine product which performs nicely and safely when installed properly. Be sure to follow all applicable recommendations contained herein.

### **Shock Hazard Warning**

Electricity can cause burns and interfere with the operation of the heart.

Working with electricity can be hazardous. Wear appropriate PPE and observe all applicable safety procedures.

The DCU may be fed by multiple sources. Beware of the stored charge on the battery and as well as power from the AC/DC source.

Repairs to a pole-mount antenna may require travel into the supply space on a pole. Only qualified personnel with appropriate PPE may work in this area.

## Fall Hazard When Working at Elevation

Working at elevation can result in the worker, parts, or tools falling to the ground below. A fall from such an elevation can result in injury or death.

Use appropriate PPE and observe all applicable safety procedures when working more than 4' off the ground. In some cases this might include a fall restraint system for the worker, hardhats for the workers on the ground below, and signage to keep the public temporarily out of the work area. Follow all instructions on the ladders and other equipment being used. Also, beware of weather conditions which may result in strong gusts of wind which may affect your safety.

## Pole-Mount Installations

The NESC describes many of the safety requirements for work on or around power poles. Only properly trained and authorized electric workers are allowed up into the supply space on the pole. Do not venture up into the supply space on the pole unless you have been properly trained in working around high voltages (12kV and higher.)

## Required Grounding

Lightning strikes could feed into AC power sources.

The equipment chassis must be grounded according to local, regional, and national codes to ensure proper protection from lightning strikes. If the DCU is ever disconnected from earth ground, while AC power is fed from building premises wiring, a lightning strike could feed into the building's power system. This could create a fire hazard within the building under some conditions.

Always ensure a proper earth ground is installed and maintained for the DCU, particularly when power is fed to it from premises wiring.

The grounding system recommended herein, and described by the grounding standards, will arrest a lightning strike and route the energy along an exterior path to ground.

## RF Exposure Hazard

Holding the antenna in one's hands while it is transmitting, or standing near a transmitting antenna for a prolonged period of time, could result in RF exposure that exceeds FCC and Health Canada recommendations.

Once the DCU is powered up and operational, it will emit RF energy. Installers, technicians, and the public at large should keep a distance of 1 meter or more from the plane of the antenna.

Most antenna mounting designs elevate the antenna well above the horizontal plane where technicians and the public might dwell. Some however do not. For these installations, it was expected that the DCU installer would have placed an RF warning sign near the antenna, or near the stairs leading to the antenna. It is still

possible however, with a ladder, a bucket truck, or by climbing the tower or pole, for a workman to find themselves near an antenna which is not labeled. These individuals are not expected to spend a long period of time near the antenna.

Some DCU designs have an optional RF-disable switch (usually mounted under the DCU chassis) that allow the technician to stop any 450 MHz radio transmissions. This lock out/tag out option should be exercised when any personnel plan to be near an operational antenna.

## **ESD Caution**

Wear suitable ESD protective gear such as grounding straps when servicing equipment.

## **Replacement Parts**

Incorrect repair parts may result in equipment damage or create an unsafe condition.

Use appropriate replacement fuses and other components when installing and repairing the equipment.

## **Rooftop-Specific Hazards**

In addition to the hazards listed above, rooftops pose a special hazard with regard to roof collapse.

Overloaded roofs can collapse. Heavy snow loads and earthquakes can add to the weight of the installation to stress roof supports and cause them to fail. Furthermore, every building is different - both in its construction and its maintenance. It is critically important that the building for which the installation is planned be studied by a civil engineer and certified for the additional load the installation will bring. It is also important that the building be inspected for structural damage prior to installation.

## **Inspect Antenna Clearance**

If another system's antenna has been installed near the Aclara antennas, it could cause interference with, or possibly even damage to, the Aclara receiver. A portable spectrum analyzer may be used to determine the power at a given location at that moment in time. If the other system is found to occasionally transmit RF energy, it may be necessary to relocate the Aclara or other system's antenna. Refer to the DCU Installation Guide for instructions on antenna mounting.



## Support

There are several ways to get help when you have a question, an issue, or would like to speak with Aclara Support.

### Aclara Connect

Aclara's customer [portal](#) enables you to access our frequently-updated knowledge database, easily access product documentation, submit and track your Support cases and RMAs, access Aclara University's Online Learning Center, track your orders, join communities and discussions with other Aclara customers and Aclara personnel, and much more. If you do not have access to Aclara Connect, email [aclarasupport@hubbell.com](mailto:aclarasupport@hubbell.com) and request access.

### Aclara University

Aclara's on-demand training makes content available to you in a convenient, cost-effective online environment. The Online Learning Center (OLC) has recordings of several webinars, streaming educational videos, software simulations, and short videos which walk you through a specific task. Access the OLC by clicking the [Aclara University](#) link on Aclara Connect.

### Technical Support

Email [aclarasupport@hubbell.com](mailto:aclarasupport@hubbell.com) or call 1-800-892-9008 to speak with an Aclara representative.

### Returning Product

To return Aclara products for repair, complete an RMA Request on [Aclara Connect](#) and provide as much detail about the problem as possible. If you have any questions regarding your return, please call 1-800-892-9008 or email [aclararma@hubbell.com](mailto:aclararma@hubbell.com).



**CHAPTER****3**

## INTRODUCTION

The Aclara RF™ or system is an automated system for taking reads from individual residential and commercial meters and sending them to a central computer where consumption can be viewed, analyzed, and integrated with a utility's other systems, such as billing.

Aclara's system consists of three main components, which work together to gather not only raw meter readings, but also generate various kinds of information that are used to monitor the performance of the system and its components. The three components are the AclaraONE headend, Endpoint Devices, the Data Collector Unit (DCU).

### AclaraONE™ Headend

The AclaraONE headend receives incoming data from the DCUs, stores the data in a repository, and displays all of the data generated by the AclaraONE network. These three functions may be divided among several servers, each performing one or more dedicated functions.

The AclaraONE headend provides information, which allows customer service personnel to look up account data while installation technicians can monitor their latest endpoint installations to confirm if they are functioning properly. AclaraONE also allows system administrators to monitor DCUs and ensure they are operating at peak efficiency or trouble-shoot issues before sending a technician into the field.

### Endpoint Devices

Aclara's RF system utilizes both endpoints and network interface cards (NICs). Examples of endpoints are Intelligent Load Control Devices (ILCs) and Demand Response Units (DRUs). Aclara's I-210, kV2, and MTU are examples of NICs. Data Collector Units (DCUs) receive data from endpoints and NICs, and this data is monitored via the AclaraONE headend..



## Data Collector Unit (DCU)

A Data Collector Unit's main purpose is to capture, store, and transmit meter readings from endpoints. DCUs are tuned to receive on the same frequency that the endpoints broadcast their readings. DCUs are installed to facilitate overlapping endpoint coverage, and endpoint readings are captured by multiple DCUs. The DCU can collect from, and transmit to, electric, gas, and water devices simultaneously.

A DCU consists of a main electronics enclosure, antennas, and either an AC or solar charging system. DCUs may be mounted on poles, buildings or towers. DCUs transmit all of the information received from the endpoints, as well as DCU operational information such as battery voltage, signal strength, and alarms to the AclaraONE headend through a variety of backhaul options.

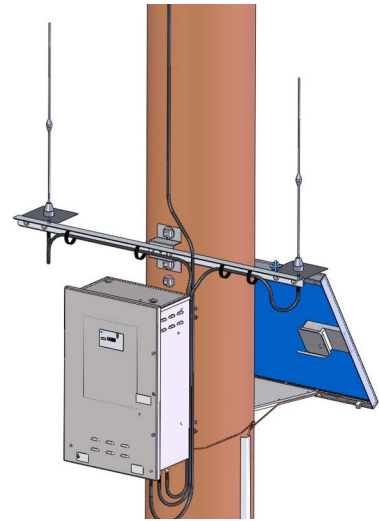

## Backhaul Options

For a DCU equipped with a single backhaul, (LTE, Ethernet, or Fiber) the DCU initiates a connection with the headend on the primary IP address. If the connection to the primary IP address fails after 6 attempts, the DCU will attempt to connect to the secondary IP address. This process will repeat until a successful connection is made. The DCU will log an error code for any failed connection attempt, including failures based on Cellular or Ethernet connection issues, and will send those messages after the first successful connection.

### LTE

An LTE cellular backhaul is available in the DCU for Verizon, AT&T, Rogers, and Bell Canada. For US carriers, customers can utilize their own private account and Access Point Name (APN), or leverage Aclara's Wireless Network (AWN) platform.

The Verizon carrier supports 4G connectivity only while AT&T supports a 3G fallback mode.

### Ethernet

The DCU can be ordered with a direct Ethernet connection through the use of an alternate main board. See additional details in the *DCU Installation Instructions, 20977-TUM* for details on wiring and connection. An Ethernet DCU supports up to a 100 Mbps data speed.

## Fiber

A direct fiber connection is also available in the DCU 2+. See additional details in the *DCU Installation Instructions, Y20977-TUM* for details on wiring and connection. A fiber connected DCU supports up to a 100 Mbps data speed.

## Failover Backhaul

Failover backhaul is a feature that Aclara's DCU 2+ now provides as a means to switch between a primary and secondary backhaul should the primary backhaul fail. This variation of the DCU 2+ allows a combination of a Cellular and Ethernet or Fiber backhaul.

Once a DCU is connected, the DCU uses periodic messages from the headend to ensure connectivity. If the DCU does not receive these commands within the specified duration, the backhaul is considered to be down. At this point, the active connection is terminated and secondary backhaul is activated.

The DCU defaults to periodically checking for the primary backhauls available through the Automatic Recovery Mode option. The user also has the option to manually control when to switch back to the primary backhaul through the AclaraOne user interface in the event of a planned outage. The DCU defaults to the Automatic Recovery Mode Option on a 6 hour duration.

It is important to note that failover backhaul functionality is enabled by default when both a Cellular and Ethernet/Fiber card are detected. In a situation where a DCU is populated with both backhauls, but one of the backhauls is not set up - either a physical line has not been run to the DCU yet, or the cell phone has purposely not been activated - the failover backhaul feature can be disabled through the local installer menu. Disabling the functionality will prevent the DCU from trying to connect to a backhaul that is not set up, which will allow a faster reconnection time with the headend in the event the connection is dropped.

## System Prerequisites

- AclaraOne 1.9
- Mainboard FW – 3.20.0012
- T-Board FW - 1.71.0054

## Solar

Fiber optic and failover DCUs consume more power than a standard cellular or Ethernet configuration. Please check with Aclara regarding solar capability for your region.

## Transceiver Board Options

The DCU II+ supports multiple transceiver cards based on the RF requirements of the network. Each transceiver board is programmed at the factory using the customer's licensed frequency information and desired security configuration.

**NOTE** Certain information is limited to factory or over-the-air (OTA) changes and cannot be changed through a local menu.

The transceiver boards can be configured to collect the following endpoints within a single DCU:

- Aclara RF Electric
- I210+, I210+C, kV2, and Distribution Automation
- Aclara RF Water/Gas
- 501, Series 33XX, 34XX, 35XX, and 4XXX MTUs

## Global Positioning System (GPS)

The DCU 2+ uses GPS to identify the location of a DCU and to provide an accurate time reference via 1 PPS signal. When the GPS service is unavailable, the system will reference the network time from the headend server.

With the DCU 2, the user enters the location information, and the system references the network time from the headend server.

## Battery Protection

### DCU 2+

The DCU 2+ can be powered from 120 VAC or solar panel(s), utilizing a sealed lead acid battery as a backup power supply in the event of a power outage or to ride through periods of inadequate sunlight.

The DCU 2+ incorporates battery protection features to maximize the overall life of the battery

The DCU 2+ battery protection process uses a solar model to properly size battery and solar panels to achieve continuous operation under most conditions. In some cases, the DCU 2+ may enter a low power mode to protect the battery. The low power mode reserves enough battery capacity to continue operation through each deployment site's probable local weather events without increasing the maximum size of the product's battery or solar panels.

During low power mode operation, the DCU 2+ will limit battery discharge, but will still allow the system to operate during daylight hours when the solar power is available. The low power mode continues to allow the DCU 2+ to send daily time syncs and provides a default wakeup mode that initiates 6 hours of meter readings beginning at approximately 10 p.m. local time every three days.

The DCU 2+ transitions between low and full power modes based on battery state-of-charge. When operating in full power mode, the DCU 2+ compares the battery state-of-charge to the seasonal state-of-charge threshold every 5 minutes.

When operating in the low power mode, the DCU 2+ compares the battery state-of-charge to the seasonal state-of-charge threshold every 60 minutes.

Initial battery protection settings are automated based on GPS-provided latitude and longitude and will only be recalculated if the GPS coordinates change by more than 1 degree in magnitude. Battery protection settings can be viewed in the “wall” or “wp” command based on firmware version can be monitored and written via the local menu or over-the-air. See *Commissioning* on page 19 for more information.

Parameter	Description	Default
Non-Winter SoC Threshold	Non-winter season state-of-charge threshold for entering low power mode	Initially set automatically based on GPS location
Winter SoC Threshold	Winter season state-of-charge threshold for entering low power mode	Initially set automatically based on GPS location
Winter Start Day	First day when winter-type weather occurs	Initially set automatically based on GPS location
Winter End Day	Last day when winter-type weather occurs	Initially set automatically based on GPS location
Wakeup Period	When system is in low power mode, this is the maximum time interval before the DCU is allowed to run from the battery to perform full power operations (daily shift)	4320 (minutes)
Wakeup Local Time	Local time of day when the system wakes up during low power mode	1320 (minute of day; this is the 1,320 <sup>th</sup> minute of the day, or 10:00 p.m.)

**NOTE** Changing default parameters may void battery warranties. Contact Aclara if needed.

## DCU 2

The DCU 2 uses a different power management mechanism than the DCU 2+, and Aclara has recently released Power Board Firmware Version 2.08 for the DCU 2. This version enhances the DCU 2’s solar charging algorithm to improve DCU battery life by reducing overcharging through PWM action on charge current during longer periods of solar charging activity. The benefits of the new charging may take some time to realize in the field, but customers may see a side-effect difference in their “Charging Current” data.

The H-board provided the headend with 4 different messages that are seen in the DCU diagnostics page which are loaded voltage, unloaded voltage, charging current, and temperature. These values are read and reported at different intervals throughout the day.? Specific to the current reading, the H-Board takes an internal fast snapshot reading every 5 minutes for one hour. The max current value read in the hour is reported to the headend. When charge current was constant, this produced a reliable reading.

Version 2.08 dynamically switches the battery current on and off, significantly increasing the possibility that the 5 minute readings occur when the battery is not being charged, even if for a few seconds. So if all the charge current reading are less than zero in an hour, the records will be zero for that hour. An example of this is shown in the 3rd frame of the figure below on May 28th when the charge current reading did not reflect the actual charge which occurred and raised the battery voltage above its natural no-charging level of 12.7V.

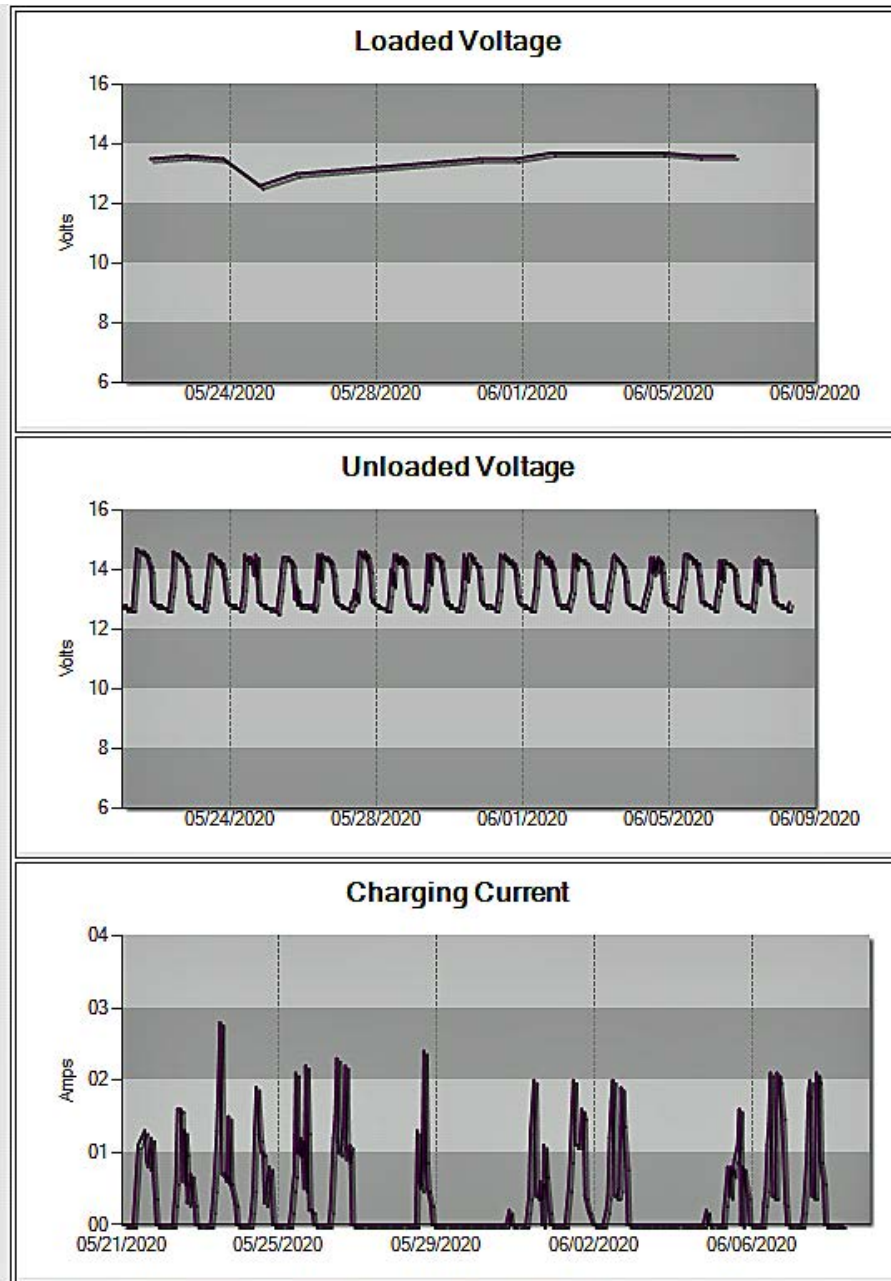



This event is more likely to be seen when the battery is at a higher charge level (to prevent life-reducing overcharge) and thus is more likely in the summer months compared to the winter months.

We understand that some customers use the charging current data to determine if a DCU's charging capability has been impacted and this may provide false positive alerts. Aclara recommends using a combination of the charging current and the unloaded voltage to minimize any false positive alerts for no charging. If charge current remains at 0A but unloaded voltage is above 13V within a 24-hour period, this indicates a working charge circuit.

## Power Management

**NOTE** This applies to DCU 2 models with firmware version 2.88 or later.

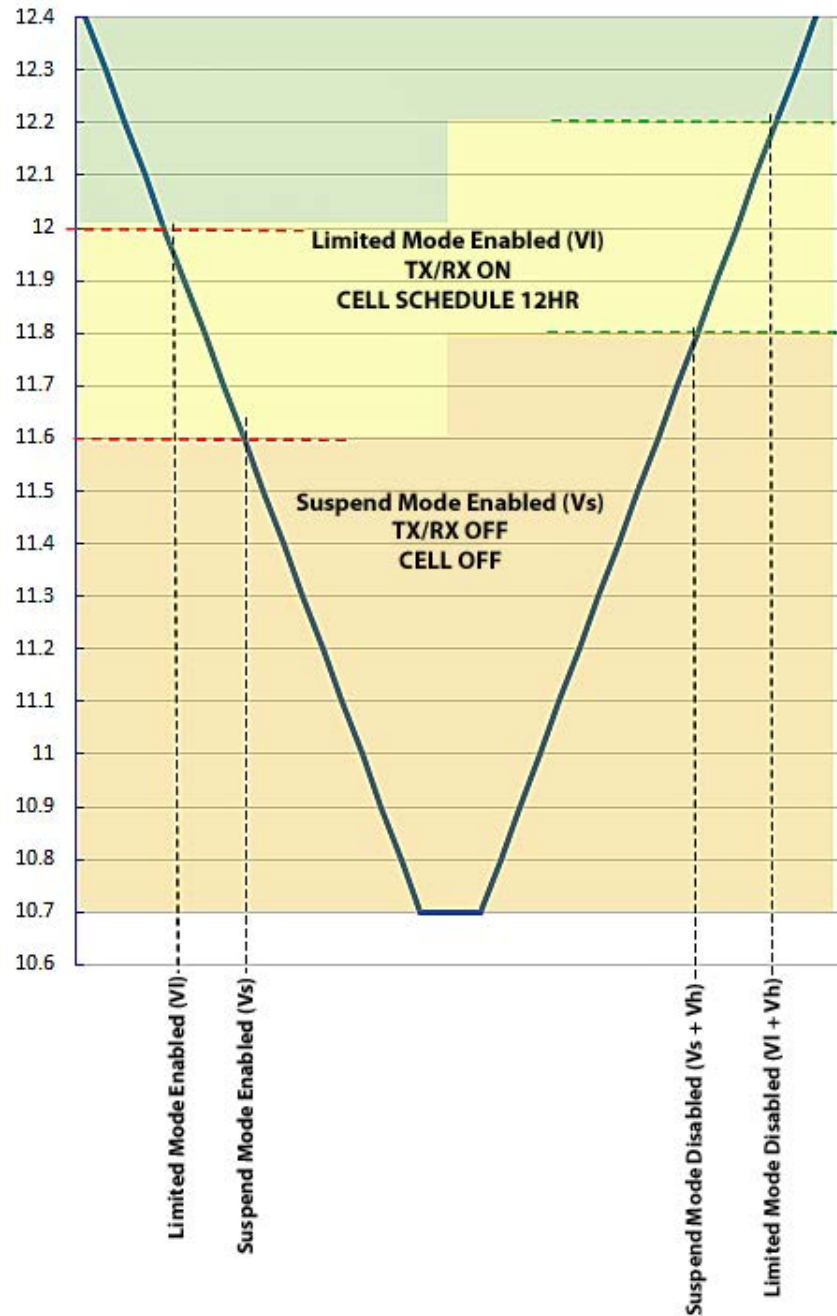

VI - Limited functionality voltage threshold (default 12.0V)

Vs - Suspend mode voltage threshold (default 11.6V)

Vh - Voltage hysteresis 0.2V

**CHAPTER****4****COMMISSIONING**

This chapter provides procedures to perform initial configuration and testing of a newly installed Data Collector Unit (DCU).

The first power-up of the DCU requires that certain configuration settings be confirmed and possibly edited. Use the following the instructions to connect your laptop to the DCU's technician port and issue commands.

The DCU design does not support public IP addresses. The installer is expected to supply a private IP address. For cellular, this requires the use of Aclara's Private Network (APN), or the utility can set up their own private network with a cellular provider. Aclara's Private Network is a part of the Aclara Wireless Network (AWN).

**NOTES** A newly installed DCU may or may not be left in a powered state by the installer. It is safer to work on the DCU with the AC power supply disconnected. If the main board is replaced in a DCU, you may need to complete this procedure once again.

**Tools Required**

- A laptop with HyperTerminal (or equivalent)
- Interface cable (Aclara #070-9975E)

**Connect to the Main Board**

1. Turn off AC power.
2. Open the DCU.
3. Verify that the serial port on the laptop is set to:
  - 115200 BAUD
  - Data Bits = 8
  - Stop Bit = 1
  - Parity = None
  - Flow control = None
4. Remove the door switch connection at the P-box.

5. Connect the black DIN connector end of the adapter cable to the technician's port in place of the door switch connection. Tighten the ring lock to ensure a complete connection.
6. Connect the D-shell connector end of the adapter cable to the serial port of the laptop.
7. Follow the menu path *Start > Accessories > Communications > Hyperterminal*.
8. Follow the menu path *File > Save As*, and enter the file name for the settings.
9. At the blinking cursor, press the **Enter** key.
10. At the `Enter Passphrase to login>` prompt, type `Sameold1`, and press **Enter**.
11. A successful login will display: `PASSPHRASE CORRECT`. This means you are logged in for console access. Upon successful login, you will have access to the Installer Menu.

**NOTE** Multiple failed login attempts will lock the programming port of the DCU for 10 minutes.

12. Upon completion of your work, disconnect the serial cable and replace the door switch connection removed in Step 4.

## Commission the DCU

1. At the technician's prompt type `w` and press the **Enter** key. The DCU will report its ID, firmware version, latitude, longitude, battery voltage, receiver frequencies, transmitter frequencies, temperature, time, date, primary call-in number, secondary call-in number, and emergency call-in number. (Depending on the backhaul type, the DCU may report an IP address).

**NOTE** Main board FW versions at 3.20 and above utilize a different "w" command structure as follows:

'w' - Backhaul, IP addresses, and Latitude/Longitude information

'wt' - Transceiver information

'wp' - Charging board information, battery diagnostics and settings

'wall' - Combination of all commands above

- 1 Ensure that all of the key parameters contain reasonable values.
  - 2 If the latitude, longitude, date, and/or time are not correct, ensure that the GPS radio is enabled. The GPS receiver may require up to 1.5 minutes after power-up to obtain a satellite fix and update these parameters. The GPS antenna is located on the top of the DCU box and needs visibility to the sky. Additional troubleshooting is available to users with administrative privileges.
  - 3 If any of the other fields do not have appropriate values, edit them using the commands found under *Installer Commands*.
  - 4 If changes must be made to the transmitter or receiver frequencies, and the changes do not take effect, it may be necessary for a user with administrative privileges to edit the available frequencies list. This list is available on the Transceiver Menu.
2. Make notes regarding the correctness of all of the settings in the log sheet and any changes that were made.

**NOTE** Be sure to save changes using **Save Configuration** in the Installer menu. This can also be done by entering an “x” at the command prompt.

3. Once you’ve confirmed that the DCU is properly identified and has correct backhaul settings, use the global command, <, or command 12 on the Installer Menu to generate test records and send them to AclaraONE. If the records transmit, it demonstrates that the backhaul is working.
4. Additional (optional) tests of the backhaul communication link can be done by someone with access to AclaraONE.
  - 1 Check the list of available DCUs in AclaraONE, and ensure the new DCU is listed and set to Active.
  - 2 The new DCU can be the target of a traceroute command. The communication latencies will be listed in the response.

With the DCU now active, data will begin to flow from any meters in the field over the backhaul into AclaraONE.

## Installer Commands

Upon login, the user will see the installer prompt (`hex\inst>`) and the installer menu. The Installer Menu provides the ability to set the essential parameters for every installation. A well trained user however may want to do more. Additional security privileges are required to navigate to other menus and perform other operations. The `CTRL+u` command will allow the user to change roles. If an administrative password is entered, the user's role will be escalated so that all menus are accessible.

There are different installer menus based on the backhaul hardware selected for the device. The following commands are provided here as a reference. Command IDs may be different based on different firmware versions.

Command	Description	Notes
1	Identity	The DCU identity must be unique.
2	Date (GMT)	
3	Time (GMT)	
4	Primary IP Address	The primary and secondary IP addresses are for the headend system.
5	Secondary IP Address	
6	Local IP Address	The Local IP address is for this DCU. It must be unique, and it must be private.
7	Call schedule	The Call schedule should be Always On when Aclara RF devices are being supported. See also command #15 below.
8	GPS coordinates	This screen allows the user to supply GPS coordinates in the event the GPS receiver is absent.
9	Show Configuration	Same as W global command.
10	Read LTC4015 Register	This is a power board charging chip troubleshooting register. Aclara Engineering Support may request data from this chip in diagnosing power board issues.
11	Create DCU Info Data	This recreates the records generated at power-up and sent to the headend. This is for informational purposes only.
12	Create Test Records	Same as global command "<<".
13	Force Call	Same as global command ">".
14	Save Configuration	
15	Enable/Disable Always On Mode	By default, the call schedule should be Always On.

---

Command	Description	Notes
16	Access Point Name	Cellular network Access Point. The APN is needed for LTE. This tells the cell phone which network to connect to. The choice of public or private networks is made by this parameter. A private network is needed to secure DCU communications.
17	GPRS User Name	By default User Name and Password are not used.
18	GPRS Password	
19	Auxiliary power	
20	Time sync schedule	Electric RF legacy setting
?	Help	

---

## DCU Console Menu

With a failover backhaul configuration, the DCU Console Menu will display the following options:

Command	Description	Notes
1	Identity	
2	Date <GMT>	
3	Time <GMT>	
4	Ethernet/Fiber Primary IP	The Ethernet/fiber and cellular options will be displayed to configure primary and secondary IPs. Ethernet/fiber will default to primary backhaul.
5	Ethernet/Fiber Secondary IP	
6	Cellular Primary IP	
7	Cellular Secondary IP	
8	Heartbeat Timeout	This option sets the total duration after which a backhaul is considered down if no commands are received from the headend; defaults to 300 seconds.
9	Switch Backhaul	This option allows the user to switch primary backhaul; can be used if fiber/Ethernet configuration is present, but a physical connection is not yet available.
10	Backhaul Recovery Mode	Automatic recovery is the default. Attempts primary backhaul after a set period of time; the default time period is 6 hours. Manual recovery requires the user to switch the backhaul via the user interface.
11	Return to main backhaul	Allows the user to immediately switch back to main/primary backhaul at the console.
12	QRC interval	This option sets the speed at which the DCU responds to the #QRC request; defaults to 75 seconds.
13	Local IP Address	
14	Disable DHCP	
15	Call Schedule	
16	GPS Coordinates	
17	Show Configuration	
18	Read LTC4015 Reg	
19	Create DCU Info Data	
20	Create Test Records	
21	Force Call	



Command	Description	Notes
22	Enable Roaming	Allows cell phone to connect if in roaming status. Intended for test purposes only. Defaulted to disabled; not recommended for field use due to increased cell phone charges.
23	Save Configuration	
24	Always On Mode	
25	Access Point Name	
26	GPRS User Name	
27	GPRS Password	
28	Auxiliary Power	
?	Help	

## Global Commands

In addition to the Installer Commands, you may also invoke any of the Global Commands described in the following table. These commands are supported on every screen.

Command	Description
E	Erase all records
F	Set/Display the receiver frequencies (Enter frequency values in Hz with a comma separating each channel. E.g. 462300000, 467300000, etc.)
V	Toggle on/off system wide verbose mode.
W	Display the current DCU configuration
X	Save the DCU configuration
Z	Toggle on/off the cell/modem power
<	Generate test DCU records for testing DCU to AclaraONE communications.
>	Force a DCU call with current settings
^	Toggle MTU message debug monitoring. This option displays records received from the MTU.
RESET	Perform a soft reset on the DCU. This reboots the DCU to the last saved configuration.
GEN1	Forces Gen1 backwards compatibility Mode
GEN2	Forces Gen2 mode
CTRL+A	Cancel active dialing sequence
CTRL+G	Displays the global DCU commands menu
CTRL+U	Prompts the user to enter the access rights pass phrase in order to change the current access rights level.
CTRL+V	Show last verbose message sent to debug window.
.	Redisplay the current menu
..	Return to the root DCU menu

## Administrator Commands (for an LTE Backhaul)

The commands available to the user will vary based on the choice of backhaul. Advanced training is required to fully understand each of the commands. The examples below show the commands available for an LTE cellular backhaul. The Ethernet model is slightly different.

Command	Description
1	Installer
2	Alarm
3	Manufacturing
4	MTU
5	Transceiver
6	Records
7	Power supply debug
8	Transceiver debug
9	Advanced
10	GNSS (Global Navigation Satellite System settings)
?	Help

When positioned at the main screen, the prompt will show `hex>`. Any numeric selection from the above will move the user down into a new command screen. The prompt will provide the command context. For example, as described above, if 1 is selected, the user will navigate to the installer screen. The prompt will once again become `hex/inst>`.

## Alarm Menu

The alarm menu allows the user to set DCU alarm settings.

Command	Description
1	Enable auto dial out
2	Interval time
3	Types/alarms masks
4	Enable readings w/alarms
?	Help

## Manufacturing Menu

The manufacturing menu provides access to information and tests.

Command	Description
1	Test memory
2	DCU PCB serial number
3	Set transceiver ch
4	Set MTU baud rate
5	Read LTC4015 Reg
?	Help

## MTU Menu

The MTU menu provides settings for configuring and troubleshooting MTUs.

Command	Description
1	Enable MTU debug
2	Target MTUs
3	Query MTUs
4	Sent time sync
5	Time sync schedule
6	Enable Series 3000 time syncs
7	Display scheduled commands
8	Display queued commands
9	Display delayed commands
10	Erase scheduled commands
11	MTU F/W upgrade status
12	Abort MTU F/W upgrade
13	Gutermann configuration
?	Help

## Transceiver Menu

The transceiver menu allows the user to view and change the transceiver settings, including transmission and reception frequencies.

Command	Description
1	Set transceiver channel
2	Front end gain
3	Available frequencies
4	DCU command
?	Help

## Records Menu

The records menu allows the user to generate, display, and erase records.

Command	Description
1	Display normal records
2	Display alarm records
3	Generate test records
4	Generate alarm records
5	Erase all records
6	Accept bad CRCs
?	Help

## Power Supply Debug Menu

The power supply debug menu provides options for troubleshooting the battery and charging circuit. These commands may be used to assert local control over the charging system.

Command	Description
1	Disable/enable verbose mode
2	Read LTC4015 Reg
3	Set battery size
?	Help

**NOTE** Historical charging data is available in AclaraONE.

## Transceiver Debug Menu

The Transceiver debug menu provides options for troubleshooting the transceiver.

Command	Description
1	Enable verbose
2	Hardware rev
3	MAC address
4	Test modulation
?	Help

## Advanced Menu

The debugging/advanced menu provides options for general troubleshooting of the main board.

Command	Description
1	Restore factory defaults
2	Enable Gen1 mode
3	Enable poll records
4	Perform software reset
5	Set modem type
6	Set bolt-on board type
7	MTU F/W upgrade status
8	Channel spacing frequency
9	Delayed 2-way time to live
10	Read physical memory
11	Disable power management
12	Enable XML RF packet decode
13	Duplicate packet filtering
?	Help

## Global Navigation Satellite System (GNSS) Menu

This menu allows the user to configure the GNSS.

Command	Description
1	Disable GPS UTC time usage
2	Disable GLONASS
3	Set C/NO threshold
4	Display position-velocity-time info
5	Display satellite info
6	Reset GPS
?	Help

If a user attempts to obtain data from the system shortly after power-up, or shortly after issuing the RESET GPS command, the system will reply with an “unable to access information” message. Information should become available once the system has fully restored.

**CHAPTER****5****MAINTENANCE**

The Data Collector Unit (DCU) is designed to minimize maintenance requirements. Performance of the DCU can be monitored via the diagnostic information sent regularly to the AclaraONE headend. DCU battery voltage, charging current, temperature, and radio frequency interference can be monitored through AclaraONE displays, which allow quick detection of problems such as faulty batteries, damaged antennas or solar panels.

When it is necessary to visit a DCU site for maintenance, a routine inspection the installation site, as well as of all components should be made. This can help to identify and avoid future maintenance needs.

**Inspecting the Site****Observe All Safety Precautions**

**CAUTION** DCUs tend to be mounted in elevated locations and are electrically powered. Observe all safety precautions when servicing the DCU. Be aware of your surroundings and of changing weather conditions which may result in lightning, rain downpours and/or gusts of wind which could impact your safety. Take appropriate countermeasures as the situation requires.

**Survey the Site**

Your visit should begin with a survey of the location. Check the area for downed lines.

Disconnect power before servicing. Observe all appropriate lockout/tagout protocols. The DCU is built to operate for many hours on battery power.

**Inspect the Mounting**

Ensure that the DCU and its antennas are mounted securely.

- Inspect bands to ensure they are not cracked, damaged, or severely rusted. Bands that have failed or near failure should be replaced.
- Inspect the mounting for any loose or missing nuts and bolts. Missing components must be replaced and secured.

The rooftop DCU which is mounted to a mast and sled must also be tethered to the building. If the tether is damaged or missing is must be replaced. A chain capable

of supporting 4,000 pounds or more will suffice. The chain may be secured with removable links. It must be attached to a structural building member (such as an I-beam) capable of supporting several thousand pounds.

## Inspect the Lock

If the DCU is within 8' of the ground, or in a public area, it must be locked according to OSHA standards. Upon arrival ensure that locks and/or tamper evident seals are in place. If they are not, make note of it, and consider escalating the matter to the DCU owner.

## Inspect the Battery

With the DCU unpowered, it will continue to operate while drawing power from the battery.

Consider the voltage charge history maintained in AclaraONE. If the head end indicates that the DCU battery has reached its end of life because it fails to hold its charge, it must be replaced.

If the battery is leaking it must be replaced.

If the battery is to be replaced, refer to the *Battery* section of the *DCU Installation Instructions, Y20977-TUM*.

If the battery is to be kept, clear any corrosion found on the battery, and ensure the bolts are properly tightened.

## Inspect the Earth Ground Resistance

It is important that sufficient earth grounding be provided in order to protect any building under the assembly from lightning.

- Verify that all bonds are secure.
- Use a ground resistance meter to verify that the resistance to ground is 10 Ohms or less.

## Colocation Assurance

New construction may result in new antennas installed near the DCU antenna. A new antenna installed near the DCU antenna may create interference. If so, a signal analyzer may be used to test the power received by the antenna from the other system.

A signal analyzer with an antenna may be positioned near the antennae and the power in the (licensed) receiving bands measured to determine the level of in-band interference.



## Antenna Clearance

New construction may cause objects to be installed near the antenna. The antenna must be mounted clear of metal objects in the horizontal plane for a distance of one antenna length. Any metal in the radiation area will result in a corresponding RF shadow on the map.

The headend may be used to issue trace route commands to endpoints which are likely to be affected. The antenna may have to be repositioned to provide a better line of sight to the affected units.

## Label Inspection

Check to see if any required labels are damaged or missing. Replace any missing labels.

- The DCU should have a label affixed to the door which identifies the (utility) owner, the utility's phone number, and possibly other information.
- An AC powered DCU has a label on the front which identifies the location of its disconnect switch.
- A rooftop DCU has a label affixed to the assembly's official grounding point at the base of the mast.
- A water tower mounted DCU, or short mast rooftop DCU should have (if appropriate) an FCC warning label near the antenna if it has been determined that workers might spend time very close to the antenna.

## General Observations

- Check cables and wires, and ensure that they are not cracked or damaged.
- Check the external connectors to ensure they remain waterproofed and free of corrosion.
- Check the internal connectors to ensure they remain properly seated and free of damage.
- Check the RF antennas, and ensure that they are not damaged or loose.
- Check the solar panel to ensure it is undamaged and free of dirt and obstructions.
- When working inside the DCU, be on the lookout for dirt and damage to electronic components, discoloration, cracking, or chipping. Components that appear to show wear may require further tests and investigation to ensure they are functioning properly.

## Servicing the DCU

The engineers at Aclara have developed a set of expectations regarding how the DCU should be maintained. The following table summarizes the types of activities a technician would be expected to perform based on the nature of the visit.

Activity	First Visit	Periodic Maintenance	Issue Investigation or Repair
Observe safety protocols	Yes	Yes	Yes
Inspect site for anomalies	Yes	Yes	Yes
Commissioning	Yes	No	No
Conduct antenna pattern test	No	Yes	As needed
Conduct cable tests	No	Yes	Yes
Recalibrate the RSSI measurement	Yes	Yes	Yes
Measure resistance to earth ground	No	Yes	As needed

## Tools & Equipment Required

The tools listed below are recommended for the maintenance and repair procedures in this chapter.

- Band strapping tool
- Phillips head screwdriver
- Inch-pound torque wrench
- Diagonal cutting pliers

## Routine Checks

When it is necessary to visit a DCU installation site for maintenance, the following checklist provides a guideline for performing a thorough **visual** inspection of DCU **internals**.



### WARNING

High voltage hazard. To avoid injury and damage to the unit, take care while working inside the protective enclosure. Do not touch or allow foreign objects to touch the AC component.

Component	Check For
Cables and wires	Cracked or damaged
	Loosened connection
Connectors	Bent or missing pin contacts; corroded or deformed socket contacts; cracked or chipped connector shell; open circuit
Protective Enclosure	Severe deformation or dents; severe rust especially around mounting holes
Cellular Antenna	Loosened or unsecured
	Damaged
RF antenna	Bent or Damaged
	Unsecured or loosened antenna
Fuses	Unsecured connection
	Bad fuses
Solar Panel	Damage, dirt, or obstructions
PCBs	Loosened or damaged electronic components; damaged circuit leads; discolored, cracked or chipped PCB
	Loosened or damaged plastic tabs
Bands	Loosened or unsecured bands; cracks or severe rust; damaged or severely bent brackets
Battery	Verify tighten to a maximum of 60 inch-pounds
	Corroded
Nuts and Bolts	Loosened nuts and bolts

## Repairs

### Repairing the DCU

Be sure to note all repairs and changes to the DCU in the maintenance log.

For safety reasons, any repairs described in this section should begin with the unit completely powered down (including disconnection from the battery) prior to commencing the repair.

When the DCU is powered down, its backhaul will also go off-line. The AclaraONE headend will be able to detect that the DCU has gone off-line and will show an off-line status on the user screen.

After the repairs are complete, the battery may be reconnected, and power must be restored to the DCU. When the backhaul is restored. The AclaraONE headend will display a status of online for the DCU.

### Replacing a Fuse

An AC powered unit is expected to have a disconnect switch, which interrupts power. The battery harness also contains a fuse which might blow.

Replace any blown fuse with a suitable, comparable fuse of the required rating. Refer to the fuse labeling or the wiring diagram for replacement fuse information.

### Replacing the Battery

Refer to the *Battery* section of the *DCU Installation Instructions, Y20977-TUM*.

## Replacing the Cellular Antenna

This procedure explains replacement of the cellular antenna.

1. Disconnect the antenna cables from the antenna package.
2. Grasp the cellular antenna on top of the DCU and turn it to the left to loosen.
3. Remove the old antenna and gasket.
4. Place a new gasket and cellular antenna onto the antenna connector.
5. Tighten antenna by turning it to the right.
6. Reconnect the antenna cables to the antenna package.

## Replacing an RF Antenna

The antenna will be located atop a mast or pole. Exercise caution in accessing the antenna. For additional information refer to the *DCU Installation Instructions, Y20977-TUM*.

**DANGER** For the pole-mounted DCU, bear in mind that only service personnel trained to work with high voltage may enter the supply space atop a power pole. It may be necessary to defer this repair to another technician who has the equipment and training required to perform a safe repair.

Use the following procedure to remove and replace the RF antenna.

1. Unlock and remove barrel lock.
2. Loosen the two thumb screws and open door.
3. Pull main power connector down to remove.
4. Remove bolts, lock washers, and nuts from the boom.
5. Replace the damaged antenna with a new antenna of the same kind.
6. Tighten the antenna to the torque cited in the *DCU Installation Instructions, Y20977-TUM*.
7. Connect the coax to the antenna, tighten, and apply waterproofing.

## Replacing a Solar Panel

Complete the following procedure to remove and replace solar panel. Refer to the *DCU Installation Instructions, Y20977-TUM* for additional information.

1. Unlock and remove barrel lock.
2. Loosen two thumb screws and open the door.
3. Disconnect the power connector.
4. Cut any tie wraps on the power cord between the DCU and the solar panel. The power cord should now dangle freely.
5. Remove the connection to ground from the old panel.
6. Remove the bolts, lock washers, and nut securing the solar panel to the mounting brackets.
7. Remove the old solar panel.
8. If the new solar panel lacks a ground clamp, and the old ground clamp is in good condition, it may be possible to scavenge the ground clamp from the old panel and install it on the new one.
9. Install the new solar panel in place of the old.
10. Secure the new panel to its mounting bracket with the bolts, lock washers, and nuts. Tighten to the torque cited in the *DCU Installation Instructions, Y20977-TUM*.
11. Attach the ground wire to the solar panel.
12. Route new power cord to the DCU and secure the cord with tie wraps.
13. Some adjustment to the length of the power cord may be necessary.
14. Some adjustment to the mount heading and angle may be necessary if it was bumped in the process of removing or installing the panels. Refer to the *DCU Installation Instructions, Y20977-TUM* for specific details.
15. Test the panel output to ensure it is supplying a suitable voltage.
16. Connect the power connection and confirm that power is being supplied to charge the battery.

## Replacing a Printed Circuit Board (PCB)

Use the following procedure to replace PCBs. Contact the Aclara RMA department for an RMA number by calling 800-892-9008 or by emailing [rma@aclara.com](mailto:rma@aclara.com).

### CAUTION

Handle circuit boards in accordance with static control procedures. The PCBs contain Electrostatic Sensitive Devices (ESDs) and may be damaged by improper handling.

Observe ESD handling instructions below to help minimize or eliminate possible damage.

- Wear static control wrist straps in contact with skin.
  - Use ESD safe tools and equipment to prevent short circuits. Use plastic, instead of metal tools, where possible to prevent short circuits.
  - Discharge static on yourself by touching a metal object before unpacking or touching PCBs or other DCU components.
  - Handle PCBs only by the edge of the board; do not touch conductive patterns or components.
1. Loosen four screws on clear PCB box cover and remove cover.
  2. Carefully disconnect any wires connected to PCB you are replacing.
  3. Remove black retaining clips on card guides using diagonal cutters.

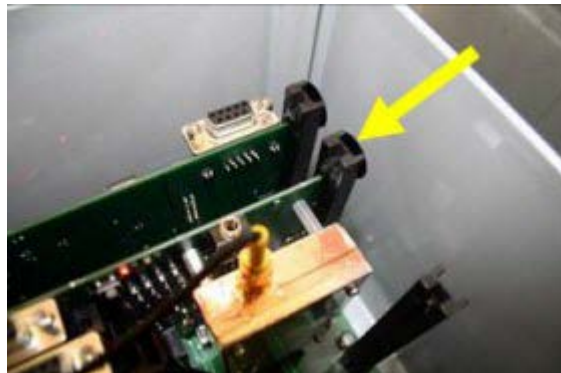

4. Remove board from locking connectors by grasping it with two hands and pulling it out.



5. After confirming your ESD ground connection, carefully unwrap new PCB and slide it into clasps. The board is fully seated when there is a slight snap.
6. If you are replacing the board, return old PCB to Aclara. Be sure to contact Aclara for an RMA number prior to returning the equipment.
7. If you are recording the FCC ID information, locate the FCC and IC information on the labels affixed to the board, and record the data.

**NOTES** FCC and IC information is located on labels affixed directly to the communication PCBs.

The use of a different radio may require a corresponding change to the nameplate label on the outside of the DCU.

## Replacing a Main Board

Use the following procedure to replace a main board in a DCU 2+.

1. Remove AC power at the switch or breaker.
2. Inside the DCU, disconnect the DC power harness from the plastic box by locating the DC power harness.



3. Pull down on the white tab.



4. Push and hold the release tab while pulling down on the connector.



5. Remove the four screws from the cover of the plastic box.

6. Ensure you are properly grounded with an ESD strap.
7. Loosen screws and remove the DB9 connectors from the main board. Note the location for each connector. You will need to reattach the connectors in the same place on the new board.
8. Loosen screws and disconnect the ribbon cable from the main board.
9. Remove the cellular coaxial cable, if it is interfering with the main board.
10. Remove the push bars installed through the card guide.

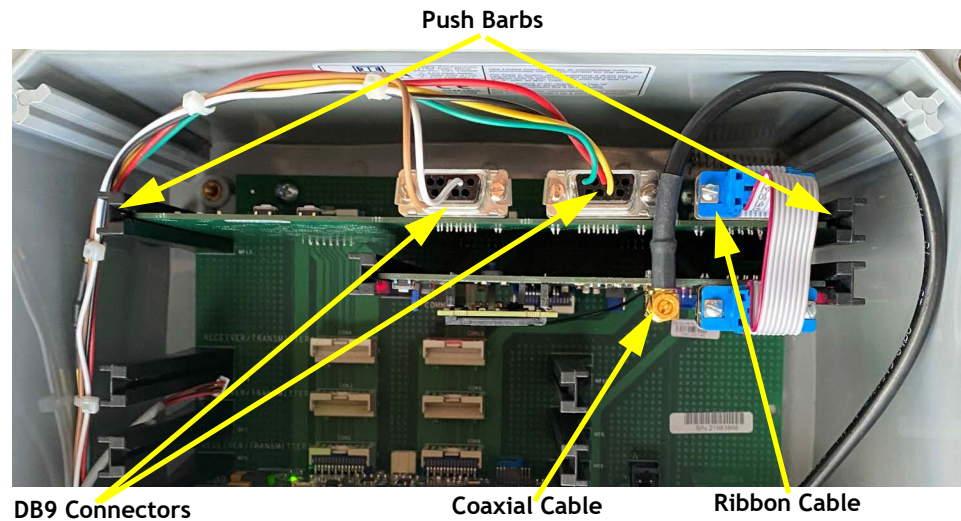

11. Pull the card out.
12. Insert the new card.
13. Reattach the cables as originally connected.
14. Replace the cover.
15. Reattach the DC power harness.
16. Reconnect AC power.

**CHAPTER****6****TROUBLESHOOTING**

This chapter contains information on troubleshooting the Data Collector Unit (DCU). For information on issues not discussed in this chapter, please contact Aclara Support at 800-892-9008.

**AclaraONE**

The first step when investigating DCU issues is to check AclaraONE. Follow the menu path *AclaraONE > Synergize RF > Equipment > DCUs > Details* or *AclaraONE > STAR > Equipment > DCUs > Details* to view the DCU Details window.

This window provides

- DCU Information
- Transceiver Information
- Cellular Information
- Call Settings Information
- TCP/IP Information
- DCU Notifications for the Past 7 Days
- DCU State Messages
- DCU RSSI Information
- DCU Diagnostics Information
- DCU Records Transferred

**Visual Check**

If you take a trip to the field to check the DCU site, check the following items:

- Condition of DCU cabinet
- RF sources interfering with the DCU
- Loose or missing cable ties

- Damaged solar panels
- Antennas
- Noticeable lightning marks - Check the antenna lightning arrestor, as well as the connections at the antenna base.
- Appropriately illuminated Printed Circuit Board (PCB) LEDs
- Cable connections
- Battery - Are the terminals clean and secure? Is the battery's state of charge above the threshold setting? Is the proper voltage present?



**WARNING**

High voltage hazard. To avoid injury and damage to unit, take care while working inside the protective enclosure. Do not touch or allow foreign objects to touch the AC component.

## Troubleshooting

### DCU Main Processor Board

- Perform a visual check of the main processor board. The following image provides an overview of what to check.

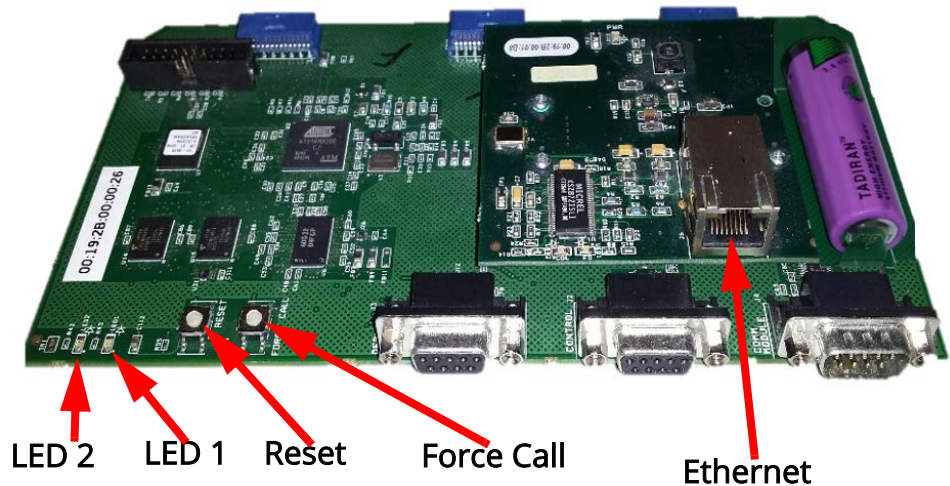

LED 1 State	LED 2 State	Status
Off	On	DCU powered down
On	On	DCU booting up
Blinking 1x/sec	Blinking 1x/sec	DCU up and running (normal)

LED 1 State	LED 2 State	Status
Off	Blinking 4x/sec	DCU processing main board firmware upgrade
Blinking 4x/sec	Blinking 4x /sec	DCU processing peripheral board upgrade
On	Off	Error processing firmware upgrade (requires reset to exit this state)

## Main Processor Board with Ethernet

- Check the Yellow / Green LEDs as indicated in the following image. These LEDs should be on continuously if the Aclara RF DCU is in “always on” mode.



Ethernet  
Yellow / Green  
activity LEDs

- Check the ethernet cabling where the ethernet cable enters the enclosure and where it connects to the motherboard. Refer to the following image for clarification.

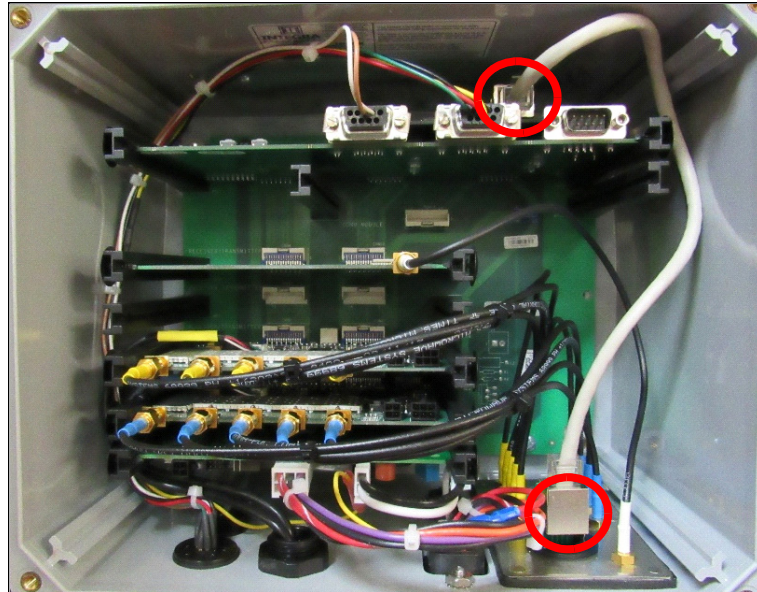

- Verify that DHCP is turned off, and verify subnet, gateway, and IP addresses.

### Main Processor Board without Ethernet

- Check the LEDs on the board. Use the following image and table for clarification.

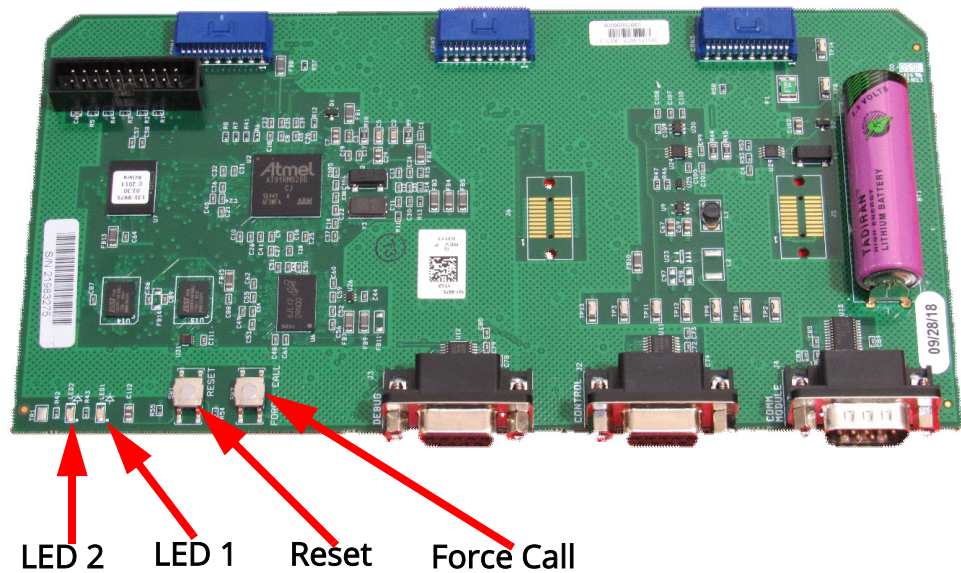

LED 1 State	LED 2 State	Status
Off	On	DCU powered down
On	On	DCU booting up
Blinking 1x/sec	Blinking 1x/sec	DCU up and running (normal)

LED 1 State	LED 2 State	Status
Off	Blinking 4x/sec	DCU processing main board firmware upgrade
Blinking 4x/sec	Blinking 4x /sec	DCU processing peripheral board upgrade
On	Off	Error processing firmware upgrade (requires reset to exit this state)

## Cellular Board

Perform these checks using the following image for reference.

- Verify the attachment of the RF antennas.
- Verify there is a secure cellular connection.

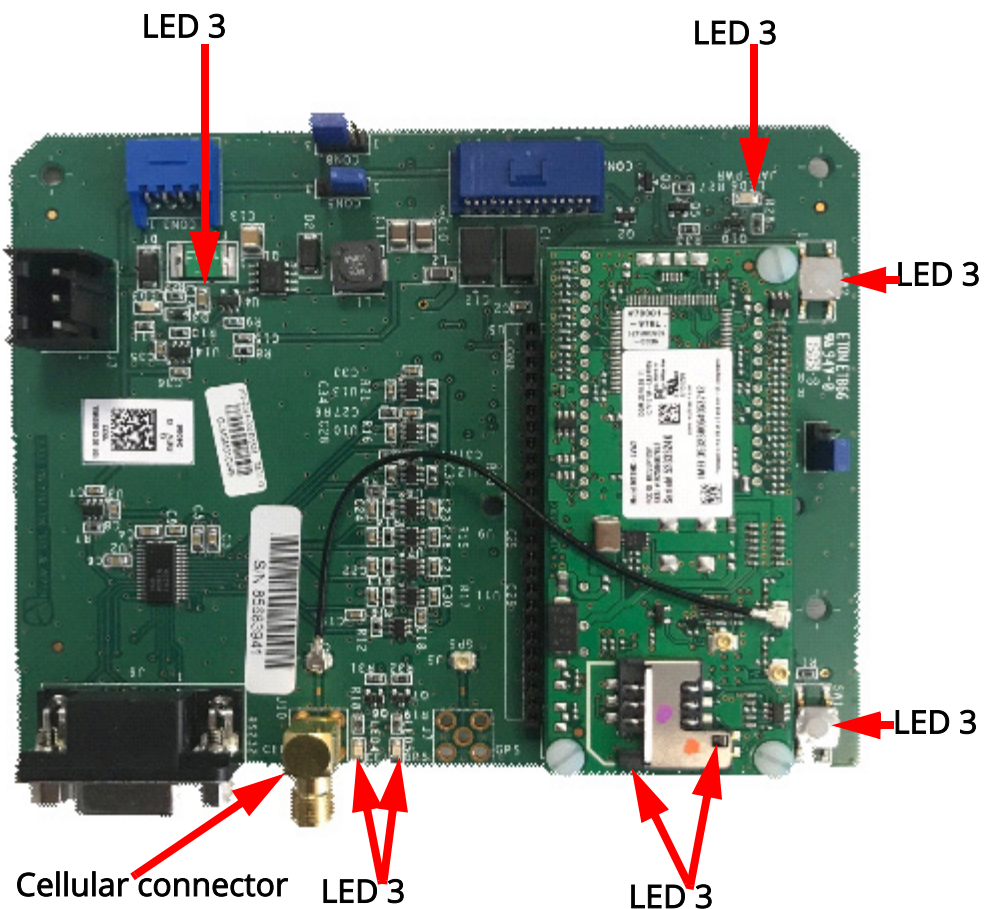

- Verify LED conditions match the information indicated in the following table.

Component	Function	State / Condition
SW1	Switch	Resets logic to cellular card (similar to power failure)
SW2	Switch	Internal/Engineering use only
LED 1	Red TX LED	Flashing (normal) - Indicates DCU transmit line to M2M module
LED 2	Red RX LED	Flashing (normal) - Indicates activity on DCU receive line from M2M module
LED 3	Red LED	ON (normal) - 5 FDC supply is running
LED 4	Red LED	Cellular activity status
LED 5	Red LED	GPS activity status
LED 6	Red LED	VAUX - Janus cellular card only

## Global Positioning System (GPS) Card

- Verify the GPS board is securely inserted into the backplane.
- Verify the gold cellular cable connector is hand tight.

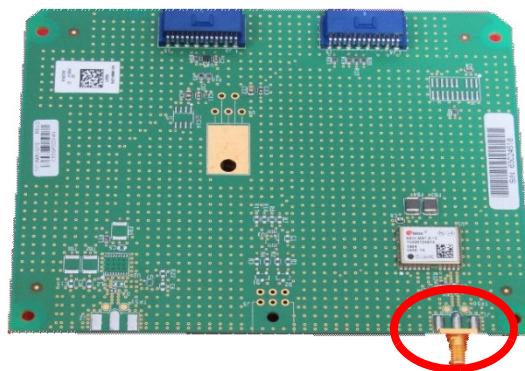

- Perform more in-depth troubleshooting using the Global Navigation Satellite System (GNSS) menu. Refer to *Global Navigation Satellite System (GNSS) Menu*.

**NOTE** Commands 1 and 2 disable GPS functionality. Command 4 allows you to adjust the sensitivity threshold for using satellite data. Commands 4 and 5 provide information regarding how many satellites you are connected to.



## Antenna

- Check the exterior condition/connection of the 4G LTE cellular/GPS antenna.



## Transceiver Board (T-Board)

- Verify the cabling at the gold connectors is hand tight.
- Check the LED activity lights, and use the following image and table for reference.

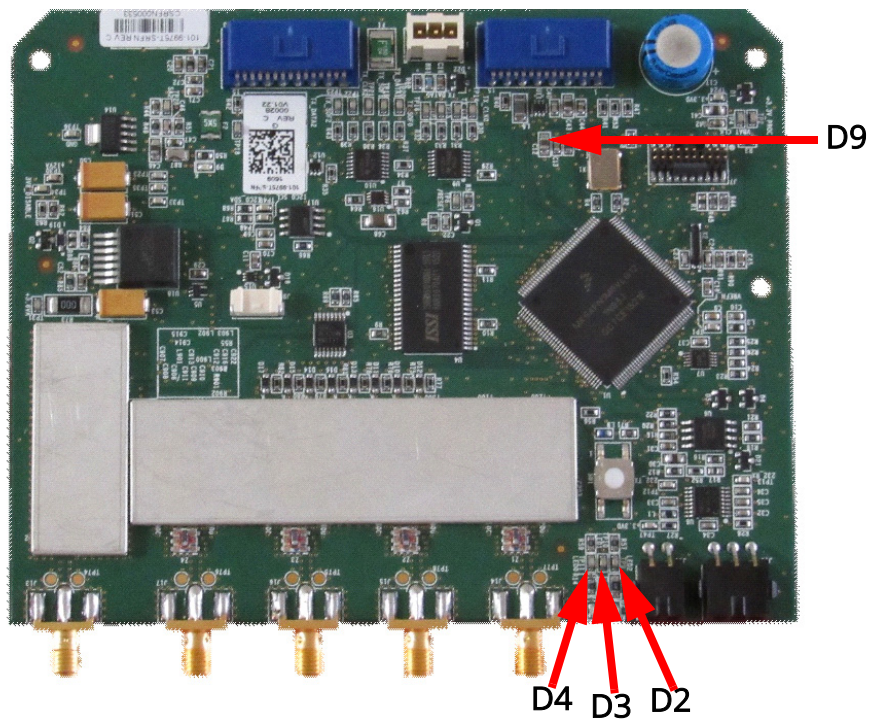

LED D2 (Blue)	LED D3 (Red)	LED D4 (Green)	LED D9 (Green)
<b>Solid on</b> - initial boot-up	<b>Off</b> - not used (normal)	<b>Flashing</b> - transmitting (normal)	<b>On</b> - 3.3 VDC power present to board (normal)
<b>Flashing</b> - boot-up completed (normal)		<b>Off</b> - not transmitting	<b>Off</b> - no power to board

## Power Supply Board

- Verify the power cables harness from the battery is attached.
- Verify the board is securely seated.
- Check LED activity lights as indicated in the following image and table.

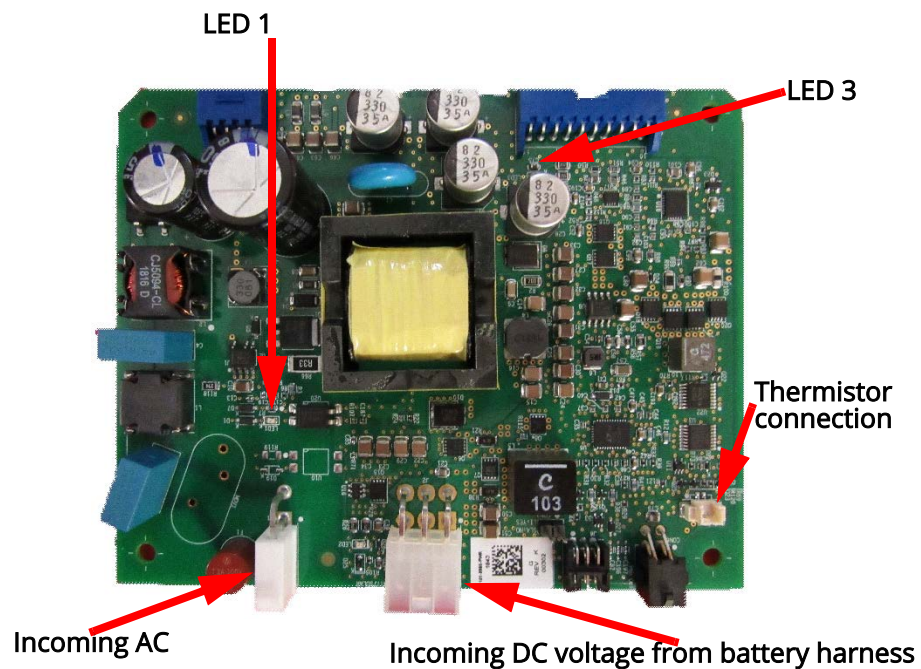

LED	State	Description
1	Off	No power to PCB
	On	Power supply board is booting
	Flashing 1x/sec	Power supply board is running
	Flashing 4x/sec	Firmware upgrade is in progress
3	Off	Solar panel or AC charger is switched off or not connected to the DCU
	On	Solar panel or AC charger is connected to the DCU

## Backplane

- Verify incoming power. If there are no LED lights or LED activity is erratic on any boards the backplane may be bad.
- Remove all circuit boards and check for damaged backplane connector pins. Refer to the following image for the connectors to check.

### Check connectors for bent pins

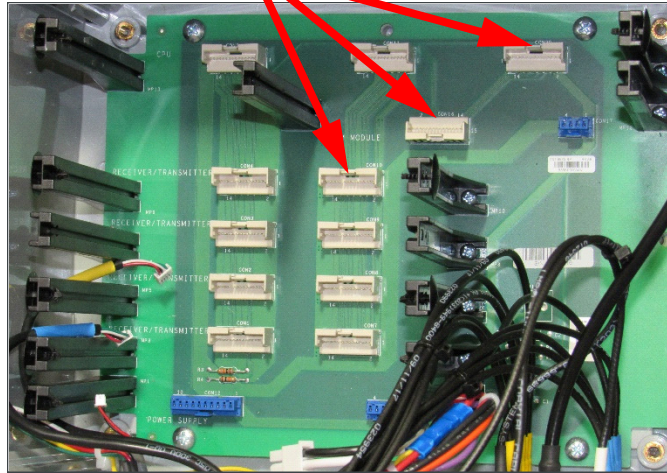

- Re-seat all circuit boards to see if the symptoms go away.
- If the symptoms do not go away, you will have to remove the backplane.
  - Remove all circuit boards using proper ESD procedures.
  - Remove four backplane screws as indicated in the following image.

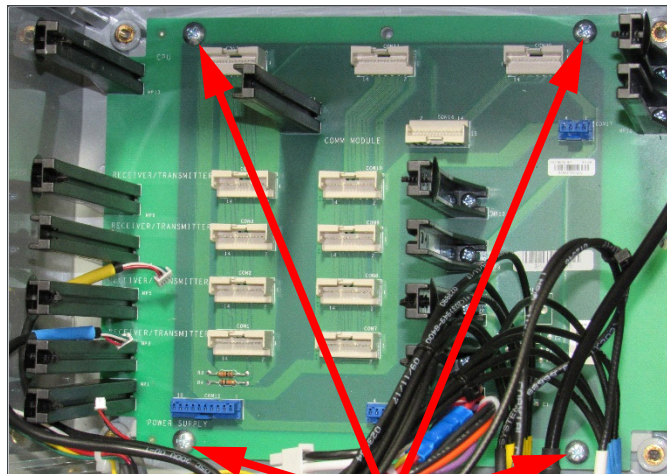

4 Phillips screws

- Replace the backplane by reversing the removal procedure above. Be sure to apply Loctite 290 to the screw threads before reattaching the backplane.
- Replace remaining circuit boards, power up DCU, and verify all circuit board LED activity.

## **APPENDIX**

# A

## **TESTING THE DCU**

This section lists a variety of different tests. Select the test(s) appropriate for your situation. Every visit does not require that every test be conducted.

### **DCU Antenna Pattern Test**

If the DCU has been found to be able to reach some locations, but not reach others, additional testing of the DCU antenna pattern may be necessary.

This test is used to measure the effect that metal near the antenna may have on the omnidirectional pattern expected from the installation. (Or alternatively, the DCU's ability to reach meters at the base of the water tower, around the corner of a building, or behind a mountain range could be tested.)

Tools Required (in addition to safety equipment):

- A laptop (or tablet) computer equipped with a cell card
- A signal analyzer which has a power meter capability
- A signal generator which can produce a carrier wave at 460 MHz with 2W continuous output
- A vehicle to travel to distant locations (optional)

### **Baseline Data**

1. The RF sweep tests should be conducted first to ensure any nearby metal is not causing undue signal reflection.
2. Disconnect the RF coaxial cables which run up to the antennae.
3. Configure a calibrated, handheld spectrum analyzer to operate in power meter mode and connect it to the Port 1 antenna output.
4. Transmit a command at the DCU and confirm that it provides 2.00 W of output power into the antenna coax. Record your results, including the time, date, and location.
5. Disconnect the RF power meter from the DCU.

## Field Data

1. Connect an RF power meter (input) to a calibrated signal generator (output).
2. Transmit 460 MHz energy from your signal generator into your power meter and confirm that the power received agrees with the power transmitted.
3. Remove your calibrated signal generator from the power meter and connect it instead to the coax and antenna (in place of the DCU).
4. Configure your handheld spectrum analyzer to capture signal strength measurements and record time, date, latitude, and longitude. Ensure that the spectrum analyzer has a GPS lock.
5. Turn on the signal generator and have it transmit a 2.00 W CW signal just as in Step 2.
6. Perform a small circular walkabout around the antenna. Collect periodic data points that start and end at the same location, and maintain a consistent distance from the antenna under test.
  - 1 A rope may be used to measure a consistent distance from the antenna. 3m and/or 10m lengths are useful.
  - 2 Collect extra samples (perhaps in 1 foot increments) in areas of interest where the power level appears to change.
  - 3 Be aware of your surroundings when conducting this test.
7. If a particular area of terrain has been reported as being problematic, the test may be continued to investigate that area. While the signal generator continues to transmit a carrier wave, travel to the test area. AclaraONE should be used to take other nearby DCUs temporarily offline. Use the handheld spectrum analyzer to take numerous data points (including time and location.) Samples should be taken in areas that are known to perform well in addition to the area under study. You could collect samples while approaching the test site, samples upon arrival, and samples when leaving.

**NOTE** If the DCU transmit frequency is occupied for a long period of time, it could cause queued commands to be rejected by the DCU(s). Depending on the nature of the issue being investigated, it may be preferable to use another licensed frequency (other than the DCU Tx frequency) so that the entire system is not tied up for the duration of the test.

- 1 Certain battery operated MTU devices may also expend more battery life as they determine if a transmission pertains to them or not.
- 2 Before leaving the affected area, the spectrum analyzer should be temporarily placed in waterfall mode to test for interferers from nearby channels.
8. Upon completion of the test, return to the DCU. Cease CW transmission. Remove the signal generator. Reconnect the coaxial cable(s) to the DCU.

Plot the results, and examine for omnidirectionality, as well as expected signal strength.

Measurements taken at 3m or 10m can be compared to the table below for anomalies.

Conducted Power (W)	Antenna Gain (dBi)	ERP (W)	EIRP (W)	dB $\mu$ V/m @ 3m	dB $\mu$ V/m @ 10m
1.0	7	3	5.0	132.2	121.7
1.5	7	4.6	7.5	134.0	123.6
2.0	7	6.1	10.0	135.2	124.8

Measurements taken at some distance must be compared to a propagation study.

Measurements should be plotted (superimposed) on a satellite image and/or street map.

Measurements taken at the same location but at different points in time should have the same signal strength. If they don't agree, there may be weather related path losses, multiple transmitters operating at the same frequency, or some malfunction of the signal generator.

## Interferer Test

If it has been observed, either through physical inspection, or because of unexpected performance problems, that a new 3rd party transmitter may be causing interference with the transmitter's or receiver's performance of the DCU, an interferer test is warranted.

Tools Required:

- A portable spectrum analyzer with real-time signal capture

User the following procedure to perform an interferer test.

1. Identify the frequencies in use by the DCU. The DCU Maintenance and Operation Manual describes a number of commands that can be used to obtain this data from the DCU directly.
2. Based on the underlying scenario, choose to either use the DCU antenna and cable or use the Signal Analyzer's own antenna. Connect the antenna to the Signal Analyzer's antenna port.
3. Place the Signal Analyzer in waterfall mode and collect data for at least 15 minutes. The SA should be tuned to capture data around the DCU transmit (and/or receive) frequencies.
4. Save the findings.
5. Use the results to quantify the severity of the interference.
6. Reconnect the DCU antenna cable (if it has been removed) and reapply the waterproofing.

## Calibrating the DCU's RSSI Measurement

This test should be run initially upon installation, and periodically (every 5 years). It should be run on a day when the outdoor temperature is reasonable.

Tools required:

- A laptop (or tablet) computer equipped with a cell card
  - A calibrated spectrum analyzer (SA) with real-time signal capture
  - A signal splitter
  - Two identical lengths of coaxial cable which are short
1. Use a browser on a laptop or tablet computer to login to the utility's corporate network, and login to a session of AclaraONE.
  2. Check the status of the DCU to determine if it is considered on-line. Set it to on-line if it is offline.
  3. From the field data identify a target meter that appears to have a good signal strength and perform reliably well.
  4. Disconnect the antenna from the DCU port and install a 1:2 signal splitter. Use one length of cable to connect the signal splitter to the DCU port. Use the other identical cable to connect the other port of the signal splitter to the spectrum analyzer.
  5. Use AclaraONE's Service And Diagnostic Tool to issue a trace route command to a nearby DCU.
  6. Note the response time, response channel, and signal strength as reported by the DCU to the headend in the trace route response. Subsequent pings of the same target should provide similar results. Start SA recording. Repeat the trace route test to ensure the command results in a response that is captured by both the DCU and the spectrum analyzer. End SA Recording.
  7. Examine the results of the trace route and compare the RSSI value reported by the DCU under test to the signal strength reported by the signal analyzer. Adjust the DCU RSSI calibration and repeat the Steps 5-6 as needed until the DCU's signal strength value agrees with the spectrum analyzer.
  8. Swap the two feeds from the signal splitter and rerun steps 5-6 to ensure the signal splitter has not introduced a bias. If the measurement is now different, make adjustments based on the average of the two.
  9. Note the changes to the RSSI calibration in the electronic and paper maintenance logs.
  10. Remove the signal splitter and restore the coaxial connection.



## Testing the Coax and Antenna

The coax and antenna will have been tested by the installer. If, over time, the performance of the DCU has degraded, testing of the coax and antenna may be warranted. It is quite possible over time that moisture or corrosion has affected the coax and the system's RF performance. The coax and antenna should be periodically tested to ensure the system is performing within recommended limits.

Tools Required (in addition to common safety equipment):

- Cable tester capable of measuring Return Loss (a.k.a. VSWR) to 1.0 within +/- 5% on a 50 Ohm coax
- A 50 Ohm precision coax load
- A zero Ohm coax load

Perform the following procedures to test the coax and antenna.

### RF Sweeps

It is important to ensure the cable provides a viable RF path to the antenna. Imperfect or damaged coax and connectors can be detected electronically. Furthermore, long cable runs, or runs with questionable turns must be examined and baselined for RF loss to ensure they will not pose a performance problem for the equipment.

### Calibration

Calibrate the cable tester to ensure it is operating properly for the 250-900 MHz band.

### Return Loss on the Coaxial Cable

Install a precision load at one end of the cable, and at the other end perform a measurement of return loss (RL) of the entire cable assembly (including all connectors, jumpers, and mainline.) Set markers at the peak and valley. Measure and record the values in dB.

### Distance to Fault (Coaxial Cable)

Install a calibrated short at one end of the cable and measure the distance to this fault from the other end. Record the distance.

### Coaxial Cable Insertion Loss

With the calibrated short at one end of the cable, determine the actual measured coax loss from the other end of the cable. (This test will measure the RF energy that is lost as heat as the signal travels through the coax.) Record the insertion loss.

## Return Loss (Antenna System)

After confirming that the coax meets specifications, remove the calibrated short and attach the antenna to the coax. With the instrument connected to the lower end of the cable, sweep the assembly which now includes the mainline, jumpers, and antenna. Set markers to frequency range boundaries in use on that line (450-470 MHz).

## Test Analysis

Save the results of these tests and name the file.

Pass criteria:

1. The instrument must not have any internal errors or fail calibration.
2. The return loss (coax) test, in which the coax was terminated with a precision load, must meet the coax manufacturer's specifications within the frequency range intended for use on the coax. A cable loss of 2 dB or more is unacceptable.
3. The Distance To Fault (DTF) test must agree with the estimated length of the coax +/- 10%.
4. Compute the expected Return Loss for the antenna system. It would be the antenna manufacturer's specified RL, plus the return loss measured on the coax in step 2) above. Add one to provide some margin. Consider this the measured "antenna system return loss".
5. A measured antenna system return loss less than 14 is unacceptable. Stated alternatively, a VSWR of 1.5 or higher is unacceptable.

The following table provides Typical VSWR and Return Loss Conversions.

Typical VSWR & Return Loss Conversions		
VSWR	% Reflected Power	Return Loss (dB)
1	0	$\infty$
1.1	0.23	26.4
1.2	0.83	20.8
1.3	1.7	17.7
1.4	2.78	15.6
1.5	4	14
1.6	5.33	12.7
1.7	6.72	11.7
1.8	8.16	10.9
1.9	9.63	10.2
2.0	11.1	9.5

6. Confirm that cable tests pass.
7. Record the results on the DCU maintenance sheet.

## Spectrum Analysis

It is occasionally useful to capture a baseline measurement of the newly installed antenna before the DCU becomes operational. This is particularly true if the antenna is suspected of potentially having issues due to a nearby transmitter.

A spectrum analyzer should be connected to the lower end of the coax and tuned to listen in the 450-470 MHz band. If the planned frequencies are known, particular scrutiny should be given to those channels to see if any strong transmissions are within the immediate vicinity of those frequencies.

Measurements should be made with the spectrum analyzer and a baseline noise level recorded around the frequencies of interest.

## Measuring Earth Ground

It is important to maintain a solid Earth ground for lightning protection. Failure to maintain proper ground can put the AC source, people, and nearby equipment at risk of lightning damage. After inspection of the bonding clamps, the resistance to ground at the DCU grounding point should periodically be tested. A solid connection to ground can be lost over time. It is easily checked.

Required Equipment:

- Earth ground resistance meter capable of measuring 10 Ohms +/- 1.5%

Procedure:

1. Follow the procedure provided with the tool.
2. Ensure the following are true:
  - All bonding clamps are in place.
  - The resistance to ground from the DCU ground point to Earth ground is 10 Ohms or less.

## Testing the Backhaul

If the DCU has been known to have difficulty staying on line, or moving data reliably, a deeper investigation of its backhaul may be necessary. The tester may wish to determine if the backhaul is working at all, or if the backhaul is performing as expected under heavy load conditions.

## Functional Testing

Tools Required:

- A laptop (or tablet) computer equipped with a cell card.

1. Use a browser on a laptop or tablet computer (equipped with cell card) to login to the utility's corporate network, and login to a session of AclaraONE.
2. Check the status of the DCU to determine if it is considered on-line. Set it to on-line if it is off-line.
3. Issue a trace route command to the DCU (with the DCU as the target).
4. Examine the results of the trace route to ensure the backhaul is operational.

## Performance Testing

The backhaul performance is also tested by the procedure described above in Functional Testing. Examine the timestamps of the transactions to ensure that data is moving reasonably well.

Additional testing of the backhaul may be possible using a performance tool supplied by your backhaul provider.

## **APPENDIX**

# B

## **LOCAL MENU "WALL" COMMAND INFORMATION**

<b>Field Example</b>	<b>Description</b>
FW Stamp: 03.20.0012	Mainboard CPU firmware version.
UserMode: Full Access	Current access permissions.
DCU Unit Number: 021499	DCU ID; this will be either a 5 or 6 digit value.
DCU PCB Number: 021499	The DCU PCB is typically just set to the above DCU ID value; however, recommend setting to the Fusion base Y-Number (i.e. DCU2+ Y63156 would be 63156).
31.035195 Lat, -85.523459 Lon	<p>This parameter represents the physical location of the DCU (East and North are positive values).</p> <p>In the DCU 2+, this value may be entered at the local menu, but will be overwritten by the internal GPS immediately if the GPS has an adequate satellite fix.</p> <p>After power-up, the value may take up to 2 minutes to populate (fix on 4 or more satellites).</p>
Telit LE910 (101-2013-002M4)	Cell phone, model number, and Aclara part number.
Phone#: 13342580649	Cell phone number; this information is obtained after the first call. After each power-up, this will display NO DATA until the next call.
IMEI: 351999098277575	Displays the serial number of the cellular socket modem.
ICCID: 89148000004649367813	Displays the SIM card identification number. After each power-up, this will display NO DATA until the next call.
F/W: 17.01.571	Firmware version of the socket modem FW.
Carrier: Verizon	Cell carrier.
H/W: 0.00	Hardware version of the cell phone, if applicable.
10T/100TX Ethernet (101-9975C)	Denotes that the DCU is equipped with an Ethernet-capable mainboard. The text would read "Fiber" for direct fiber-capable connections.

Field Example	Description
LTE Mode	
APN: xxxxxxxxxx	Displays the APN configured the for the DCU. Check to ensure the appropriate APN is used to avoid connectivity errors.
User/Pswd:	Displays the Username and Password associated with the APN; it is standard that these are blank.
Main Backhaul: Cellular	Displayed in Failover Backhaul configurations. Defines the Main/Primary Backhaul the DCU will use to connect. This can be changed in the menu.
Ethernet/Fiber Backhaul IP1: 10.XX.X.XX, 23XXX	Defines the IP address and port for the Ethernet or Fiber connection. Ensure this information matches the customer server requirements.
Ethernet/Fiber Backhaul IP2: 10.XX.X.XX, 23XXX	The second IP address can be used for a data recovery server in the event the primary server is down. If a customer is only using a single server IP, the settings in the IP1 are to be mirrored.
Cellular Backhaul IP1: 10.27.X.XX, 23XXX *	The IP addresses for the cellular connection typically route through a client VPN and are different than the Ethernet/Fiber IP addresses. The secondary IP address should be the same as the primary unless a data recovery server is in use. An * indicates the IP and Port the DCU is actively connected to.
Cellular Backhaul IP2: 10.27.X.XX, 23XXX	
DHCP ON	The cellular IP address may be dynamically generated by a network DHCP server or statically set. To use a static IP address set DHCP=OFF, and set the IP address below. To use dynamic IP address, set DHCP=ON and let DHCP server select your IP address below.
MyIP Address: 10.120.9.8	Defined by the network: 32-bit number assigned to each device consisting of network address (10.120.9) and host address (8). This number is auto-generated with DHCP on. When DCHP is off, this IP address will be entered based on customer networking requirements.
MySubnet Mask: 255.255.255.0	Defined by the network, this is used to determine the bits used for the network address and therefore allows you to separate the network address bits from the host bits.
MyGateway: 192.168.1.1	Defined by the network, this 32-bit number is assigned to a router (Default Gateway) that is used to communicate with other networks. This number is auto-generated with DHCP on. When DCHP is off, this IP address will be entered based on customer networking requirements.
MyDNS Server1: 192.168.1.1	Defined by the network; this is the IP Address of a primary AclaraOne server. This number is auto-generated with DHCP on. When DCHP is off, this IP address will be entered based on customer networking requirements.

Field Example	Description
MyDNS Server2: 192.168.1.1	Defined by the network; this is the IP Address of a secondary AclaraOne server. This number is auto-generated with DHCP on. When DCHP is off, this IP address will be entered based on customer networking requirements.
MyMAC Address: 00:19:2b:00:5e:54	MAC ID address of the Ethernet/fiber daughter board.
MyMTU Size: 1514	MTU Size is the maximum size of the Ethernet packets the DCU can transmit. Defaults to 1514 for Ethernet. Minimum size allowed is 512.
Auto Negotiate ON	This allows the system to automatically set the Ethernet network speed (i.e. 10 Mbps or 100 Mbps) based on connection. Problems can arise if either side hard sets its rate to 100Mbps. Manual setting of the speed should not be needed unless auto-negotiating is failing (perhaps due to very old switch).
MyIP Address (cellular): 10.80.1.8	This is the IP Address of the Cellular device after the SIM card has been activated.
AC/DC Power Supply (9985H)	Version of the power supply/charging board. 9975H is the legacy board and would provide slightly different parameters
S/N: 00000000	Serial number of the power supply. All 9985H boards will be 00000000. 9975H units will have a unique ID.
H/W: A	This is the hardware version of the power supply board, if applicable.
Battery Hardware settings	This is only applicable for the 9985H board.
Battery Size = 41(Ah)	Size of the installed battery. Factors into the State of Charge (SoC) calculation. The default size is 41Ah if battery count equals 1, but will default to 30Ah if battery count equals 0. Value can be changed to 30Ah if appropriate.
Battery Count = 1	Defaults to "1". Check to ensure this is correct. At this time, the DCU only supports a single battery, but menu allows battery count to be set to 0, 1, or 2.
Cell count = 6	Lead Acid battery detection results in "6". Value is based on the detection of a supported battery. This allows for future support for combinations of different battery sizes.
AC powered = YES	Indicates whether the DCU is detecting AC power. AC Power requires at least 2 cycles to detect. AC power will detect 50/60Hz 120VAC +/- 20%.
Solar powered = NO	Indicates whether the DCU is detecting DC power. DC power detection requires an input voltage between 10.9VDC-23VDC (maximum 5.9amp ratings).
Battery type = Lead-Acid	Reports the Battery chemistry type the charging board is set for. Default is Lead-Acid.
Freeze protection settings:	This only applies to the 9985H board.

Field Example	Description
Non-winter SoC Threshold = 20%	Defaults to 20% and never should be less than 20%. This is the threshold at which the DCU will enter low power mode outside the winter start and stop days. This value is automatically calculated based on GPS-obtained coordinates.
Winter SoC Threshold = 25%	Defaults to 25% and never should be less than 20%. This is the threshold at which the DCU will enter low power mode within the winter start and stop days. This value will normally be greater than the non-winter SoC threshold. This is value is automatically calculated based on GPS-obtained coordinates.
Winter Start Day = 1(day of year)	Start day in which the Winter SoC threshold will become active. This value is automatically calculated based on GPS-obtained coordinates
Winter End Day = 26(day of year)	End day in which the SoC threshold will revert to the Non-Winter threshold settings. This value is automatically calculated based on GPS-obtained coordinates.
Full Power Consumption = 4000(mW)	Defaults to 4000mW. Value can be changed if standard DCU 2+ hardware or traffic changed. This is the average power consumption of the DCU electronics in normal operating mode.
Low Power Consumption = 450(mW)	Defaults to 450mW. Value can be changed if standard DCU 2+ hardware or traffic changed, but this value should not need to be changed for the DCU 2+. This is the average power consumption of the DCU electronics in low power operating mode, alias "sleep mode".
Measurements	Note that only some of these are available with the 9985H board
Battery SOC = 90%	State of Charge of the battery. Valid range is 0 to 100%. This value is what is compared to the Freeze Protection settings to determine low vs, normal operation mode. For AC systems, the SoC should be steady and above 89%. For solar DCU 2+, the SoC will increase when sunlight is available and will discharge when sunshine is not available.
Power Management Mode: Normal Operation	Denotes the current state of the DCU. Will be Normal or Low/Suspend Mode. (Battery State of Charge above threshold)
Battery BSR = 0.060Ohm	Battery Series Resistance. The higher the value, the lower available capacity of the battery. This value can be viewed over time to determine a failing battery.
Battery Voltage = 13.10V	The OC battery voltage. In a DCU 2, this value needs to be over 12V for normal operation. In the DCU 2+, the SoC value is a better indication of battery charge.
Input Voltage = 19.13V	Power Board input DC voltage (Vin). The capable of handling voltages up to 25VDC for a typical solar panel. AC circuits provide ~19VDC to this input.
Module Voltage = 19.10V	Voltage provided to load (Vsys) should be near battery voltage during discharge and near input voltage when charging.
Battery Current = 01.27A	Battery Current (Ibat) is positive when the battery is charging and negative when the battery is discharging.



Field Example	Description
Input Current = 01.24A	Power Board input current (lin) is the current provided to the power board.
Power Supply Module Temp = 71.27C	Die Temperature of the LTC4015 Power Supply Chip. This value should never exceed 125C and is actively controlled. During full solar charging of a depleted battery, the temperature will likely approach 115C.
Battery Temp = 30.09C	Temperature taken at the thermistor on the battery lug. This temperature should be close to the outside ambient temperature. Valid range is -60C to 80C. -99C value (or future alarm) indicates a bad or missing thermistor that must be replaced for optimal battery charging.
DCU battery charging = YES	Indicates the battery charging state at the time of reading the configuration.
Wakeup settings:	Applicable only for the 9985H board, this specifies the operation when the DCU is in low power mode. These default values should never be adjusted without Aclara Engineering direction.
Wakeup Period = 4320(Minutes)	Sets the amount of minutes between each service time. The default is 4320 minutes (72 hours). Every 72 hours, the DCU will wake up and operate in normal operating mode for the duration of the service time. This default value should never be adjusted without Aclara Engineering direction.
Wakeup Local Time = 1320(Minute of Day)	Sets the local time of day that the DCU will wake up during the wakeup service period. Default is 1320 (10pm Local time). The DCU estimates local time from longitude so the local wakeup time may be off by an hour. This default value should never be adjusted without Aclara Engineering direction.
Wakeup Service Time = 360(Minutes)	Sets the duration the DCU will remain in normal operating mode. The default is 360 minutes (6 hours). This default value should never be adjusted without Aclara Engineering direction.
Power report settings:	<p>Power Data Logging Only Applicable for the 9985H Board</p> <ul style="list-style-type: none"> <li>• Battery Power Modes</li> <li>• Bulk: High voltage and current phase when state of charge is between 0 and ~80% when battery can accept charge without overheating.</li> <li>• Absorb: Constant voltage with decreasing current phase when state of charge is between ~80% and 95% to prevent battery overheating</li> <li>• Float/Trickle: Charging current reduced to less than 1% of battery Ahr capacity.</li> <li>• Discharge: Battery state-of-charge declines; each charge/discharge cycle reduces battery life</li> </ul>
Absorb charge state report interval = 2(minutes)	Frequency of firmware reporting of power statistics when battery in Bulk or Absorb Mode Expected Values: 0=Inactive, 1 to 144 (10 to 1440 minutes) Default Value = 2 (20 minutes).

Field Example	Description
Non-absorb charge state report interval = 6(minutes)	Frequency of firmware reporting of power statistics when battery is Float Mode (steady voltage) Expected Values: 0=Inactive, 1 to 144 (10 to 1440 minutes) Default Value = 6 (60 minutes).
No charge state report interval = 0(minutes)	Frequency of firmware reporting of power statistics when battery is discharging Expected Values: 0=Inactive, 1 to 144 (10 to 1440 minutes) Default Value = 6 (60 minutes).
Absorb charge state readings = 0x7E	Identifies the battery parameters to return in absorb and bulk modes based on bit mask: 0x01 = Power Supply Temperature 0x02 = State of Charge 0x04 = Input Current 0x08 = Input Voltage 0x10 = Battery Temperature 0x20 = Charge Current 0x40 = Battery Voltage 0x80 = System Voltage Default value = 0x7E (which brings back everything except System Voltage and Power Supply Temperature)
Non-absorb charge state readings = 0x7E	Identifies the battery parameters to return in float modes based on bit mask: 0x01 = Power Supply Temperature 0x02 = State of Charge 0x04 = Input Current 0x08 = Input Voltage 0x10 = Battery Temperature 0x20 = Charge Current 0x40 = Battery Voltage 0x80 = System Voltage Default value = 0x7E (which brings back everything except System Voltage and Power Supply Temperature)
No charge state readings = 0x7E	Identifies the battery parameters to return in discharge modes based on bit mask: 0x01 = Power Supply Temperature 0x02 = State of Charge 0x04 = Input Current 0x08 = Input Voltage 0x10 = Battery Temperature 0x20 = Charge Current 0x40 = Battery Voltage 0x80 = System Voltage Default value = 0x7E (which brings back everything except System Voltage and Power Supply Temperature)

Field Example	Description
Receiver02: 9975T	Transceiver information for the card in slot 2.
MAC address: 00:1d:24:00:01:04:9a:6b	Assigned T-Board media access control address (MAC ID).
F/W Rev: 01.73.0003	Firmware revision of the board.
H/W Rev: B	Hardware revision of the board.
Radio Temperature = 47.0C	Die temperature of radio chip assigned to transmit.
Processor Temperature = 47.6C	Die temperature of T-Board MK64FN1M0VLQ12 processor.
Power Supply Temperature = 46.8C	Power Supply Board chip temperature.
Power Amp Temperature = 44.2C	Radio Board Power Amplifier Temperature.
+12V monitor = 12.027V	Power Supply Board output voltage provided to electronics.
Date/Time = 06/10/2020 15:12:20	Date and time on the transceiver boards. This should be the same the time on the Mainboard located at the bottom of the 'w' or 'wall' command output.
456387500:RSSI=-122.0dB:-121.9dB, 456437500:RSSI=-123.0dB:-123.0dB, 456637500:RSSI=55.0dB:55.0dB, 457087500:RSSI=55.0dB:55.0dB, 457412500:RSSI=55.0dB:55.0dB, 457862500:RSSI=55.0dB:55.0dB, 457887500:RSSI=55.0dB:55.0dB, 467362500:RSSI=55.0dB:55.0dB	Provides the instantaneous background noise measurements for each programmed channel.
Available Frequencies 456387500,456437500, 456637500,457087500, 457412500,457862500, 457887500,467362500,,,,,,,,,,,,, ,,,,,,,,,,,,	Available Frequencies is a list of all licensed frequencies for a deployment. These frequencies are programmed at manufacturing and are the superset of frequencies that can be used for the Transmit and Receive frequencies.
Front End Gain= -10.0dB	Front End Gain is currently programmed during manufacturing value and is used in Aclara RF devices to adjust the transceiver board's reported RSSI values to compensate for the gain of the front end modules.

Field Example	Description
Gateway Config = NONE	<p>The Gateway type (STAR/SRFN/NONE) indicates what type of network data the headend should route to this T-board.</p> <ul style="list-style-type: none"> <li>The NONE state is typically only used on 1 T-Board in an electric-only DCU 2+ containing two T-Boards.</li> <li>T-Boards with a gateway=NONE send registration, hourly T-Board statistics, and hourly RSSI statistics.</li> <li>T-Boards with a gateway=NONE will not be used by Headend to send data to endpoints.</li> </ul>
SRFN mac channel sets = 467362500,467362500, 456000000,458000000,,,,,,,,,,,,, ,,,,,,,,,,,,,	These channels identify the frequencies that a SRFN message will select when transmitting. The first two values in the set define the range.
STAR mac channel sets = 466600000,468000000, 456000000,458000000	These channels identify the frequencies that a SRFN message will select when transmitting. The first two values in the set define the range.
Transceiver 2 Channel Configuration	The following Transceiver 2 rows provides the frequencies assigned to the slot 2 T-Board radios.
Rx Channel 1 00000000 INACTIVE	Slot 2 Radio 1 Frequency. '000000000' or 'INACTIVE" used if radio is off
Rx Channel 2 00000000 INACTIVE	Slot 2 Radio 2 Frequency. '000000000' or 'INACTIVE" used if radio is off
Rx Channel 3 00000000 INACTIVE	Slot 2 Radio 3 Frequency. '000000000' or 'INACTIVE" used if radio is off
Rx Channel 4 00000000 INACTIVE	Slot 2 Radio 4 Frequency. '000000000' or 'INACTIVE" used if radio is off
Rx Channel 5 00000000 INACTIVE	Slot 2 Radio 5 Frequency. '000000000' or 'INACTIVE" used if radio is off
Rx Channel 6 00000000 INACTIVE	Slot 2 Radio 6 Frequency. '000000000' or 'INACTIVE" used if radio is off
Rx Channel 7 00000000 INACTIVE	Slot 2 Radio 7 Frequency. '000000000' or 'INACTIVE" used if radio is off
Rx Channel 8 00000000 INACTIVE	Slot 2 Radio 8 Frequency. '000000000' or 'INACTIVE" used if radio is off
Tx Channel SRFN 467362500 SRFN	Frequency used for SRFN transmit messages and time syncs (Slot 2 Radio 9)

Field Example	Description
Tx Channel STAR 467362500 STAR	Frequency used for STAR transmit messages and time syncs (Slot 2 Radio 9)
Receiver02: 9975T	Transceiver information for the card in slot 3.
MAC address: 00:1d:24:00:01:03:bf:e8	Assigned T-Board media access control address (MAC ID).
F/W Rev: 01.73.0003	Firmware revision of the board.
H/W Rev: B	Hardware revision of the board.
Radio Temperature = 45.0C	Die temperature of radio chip assigned to transmit.
Processor Temperature = 44.8C	Die temperature of T-Board MK64FN1M0VLQ12 processor.
Power Supply Temperature = 46.0C	Power Supply Board LTC4015 chip temperature.
Power Amp Temperature = 44.9C	Radio Board SKY 65160 Power Amplifier Temperature.
+12V monitor = 12.068V	Power Supply Board output voltage provided to electronics.
Date/Time = 06/10/2020 15:12:2	Date and time on the transceiver boards. This should be the same the time on the Mainboard located at the bottom of the 'w' or 'wall' command output.
456387500:RSSI=-129.0dB:-128.9dB, 456437500:RSSI=-129.0dB:-128.9dB, 456637500:RSSI=-129.0dB:-128.9dB, 457087500:RSSI=-129.0dB:-128.9dB, 457412500:RSSI=-129.0dB:-128.9dB, 457862500:RSSI=-129.0dB:-128.9dB, 457887500:RSSI=-129.0dB:-128.9dB, 467362500:RSSI=-129.0dB:-128.9dB	Provides the instantaneous background noise measurements for each programmed channel.
Available Frequencies 456387500,456437500, 456637500,457087500, 457412500,457862500, 457887500,467362500,,,,,,,,,,,,, ,,,,,,,,,,,,	Available Frequencies is a list of all licensed frequencies for a deployment. The DCU must not receive or transmit on frequencies not contained in this list.  For some test purposes, the list may be populated with itinerate frequencies: Tx 1: 461.363 MHz Rx 1: 466.038 MHz Rx 2: 466.063 MHz Rx 3: 466.088 MHz Rx 4: 466.113 MHz Rx 5: 466.138 MHz Rx 6: 466.163 MHz Rx 7: 466.188 MHz

Field Example	Description
Front End Gain= -10.0dBm	<p>Front End Gain is currently programmed during manufacturing value and is used in SRFN devices to adjust the SiLabs reported RSSI values.</p> <ul style="list-style-type: none"> <li>The phyFrontEndGain represents the calculated front end gain (in decibels) from the lightning arrestor (through FEM) to the T-Board SiLabs radio.</li> <li>For DCU 2+, the front end gain is set to 10dB (2*phyFrontEndGain).</li> <li>The DCU 2+ front end gain does not include any compensation for antenna gain or antenna cable loss.</li> <li>The phyFrontEndGain value is used to calculate RSSI values.</li> <li>RSSI values reported by a DCU 2+ with a Laird antenna (5dBi) will be higher than RSSI values reported by an EMWave antenna (3dBi).</li> </ul>
Gateway Config = SRFN	<p>The Gateway type (STAR/SRFN/NONE) indicates what type of network data the headend should route to this T-board.</p> <p>The NONE state is typically only used on 1 T-Board in an electric-only DCU 2+ containing two T-Boards.</p> <ul style="list-style-type: none"> <li>T-Boards with a gateway=NONE send registration, hourly T-Board statistics, and hourly RSSI statistics.</li> <li>T-Boards with a gateway=NONE will not be used by Headend to send data to endpoints.</li> </ul>
SRFN mac channel sets = 467362500,467362500, 456000000,458000000,,,,,,,,,,,,, ,,,,,,,,,,,,,	<p>The MAC is the control abstraction for the Radio physical layer.</p> <ul style="list-style-type: none"> <li>These channels identify the frequencies available for assignment to the SRFN network</li> <li>May be referenced by alias of macChannelSets.</li> <li>SRFN MAC Process: <ul style="list-style-type: none"> <li>MAC receives a request to transmit a SRFN frame.</li> <li>MAC looks in macChannelsSets and SRFN phyTxFrequencies to create list of valid transmit channels.</li> <li>MAC randomly (if more than one) selects a transmit frequency from list for frame so recommended that each board should only provide one SRFN transmit frequency.</li> </ul> </li> </ul>
STAR mac channel sets = 466600000,468000000, 456000000,458000000	<p>The MAC is the control abstraction for the Radio physical layer. These channels identify the frequencies available for assignment to the STAR network Alias macChannelSetsSTAR. STAR MAC Process:</p> <ol style="list-style-type: none"> <li>MAC receive a request to transmit a STAR frame.</li> <li>MAC looks in macChannelsSetsSTAR and STAR phyTxFrequencies to create list of valid transmit channels</li> <li>MAC randomly (if more than one) selects a transmit frequency from list for frame so recommended that each board only provide one STAR transmit frequency.</li> </ol>

Field Example	Description
Transceiver 3 Channel Configuration	The following Transceiver 3 rows provides the frequencies assigned to the slot 3 T-Board radios.
Rx Channel 1 SRFN 467362500	Slot 3 Radio 1 Frequency. '000000000' or 'INACTIVE" used if radio is off
Rx Channel 2 SRFN 456387500	Slot 3 Radio 2 Frequency. '000000000' or 'INACTIVE" used if radio is off
Rx Channel 3 SRFN 456437500	Slot 3 Radio 3 Frequency. '000000000' or 'INACTIVE" used if radio is off
Rx Channel 4 SRFN 456637500	Slot 3 Radio 4 Frequency. '000000000' or 'INACTIVE" used if radio is off
Rx Channel 5 SRFN 457087500	Slot 3 Radio 5 Frequency. '000000000' or 'INACTIVE" used if radio is off
Rx Channel 6 SRFN 457412500	Slot 3 Radio 6 Frequency. '000000000' or 'INACTIVE" used if radio is off
Rx Channel 7 SRFN 457862500	Slot 3 Radio 7 Frequency. '000000000' or 'INACTIVE" used if radio is off
Rx Channel 8 SRFN 457887500	Slot 3 Radio 8 Frequency. '000000000' or 'INACTIVE" used if radio is off
Tx Channel SRFN 467362500	Frequency used for SRFN transmit messages and time syncs (Slot 3 Radio 9)
Tx Channel STAR 467362500	Frequency used for STAR transmit messages and time syncs (Slot 3 Radio 9)
Temp: 30.1C (86.2F)	Temperature inside the outer DCU enclosure when data was collected (calculated by Mainboard from battery thermistor).
Time: 15:12:19	Mainboard UTC (not local) when data collected.
Date: 06/10/20	Mainboard Date (Month/day/Year) when data collected.
Call In Time: 15:10:45	UTC Time (hours/minutes/seconds) when collected data was passed to the headend.
Call In Interval: 00:05 (Always ON w/fast alarms)	Time between call-ins in minutes for older STAR DCU 2s. Newer DCU 2+ should be always on.
Call In Attempt: 00	Count of recent call-in for this data. '00' may imply always on.

---

Field Example	Description
Normal Records: 00000000	End-point records count associated with collected data.
Alarm Records: 00000000	End-point alarm count associated with collected data.

---



**APPENDIX**

**C**

**DCU-GENERATED HEADEND MESSAGES**

Source	Message	Frequency	DCU 2	DCU 2+	Mainboard Firmware	Description
Cell Module	BER=7	Each call attempt	X	X		Bit error rate (in percent) after AT+CGREG command sent out. Value take after registration with the cell tower Index of RSRQ (dbM) for LTE: 0: (-4) to (-3) 1: (-6) to (-5) 2: (-8) to (-7) 3: (-10) to (-9) 4: (-13) to (-11) 5: (-15) to (-14) 6: (-17) to (-16) 7: (-19) to (-18) 99 - not known or not detectable
Cell Module	CADC=3.76V	Each call attempt	X			Bit error rate (in percentage) (for CDMA and HSPA) 0 - less than 0.2% 1 - 0.2% to 0.4 % 2 - 0.4% to 0.8% 3 - 0.8% to 1.6% 4 - 1.6% to 3.2% 5 - 3.2% to 6.4% 6 - 6.4% to 12.8% 7 - more than 12.8% 99 - not known or not detectable
Cell Module	CCAD=1	Each call attempt	X			Battery voltage being supplied to the module; used with CDMA phones.  Result of AT+CAD command used for CDMA phones. It returns one of the following codes: 0: If no service is available 1: If CDMA digital service is available 2: If TDMA digital service is available 3: If analog service is available (values 4 to 255 reserved)

Source	Message	Frequency	DCU 2	DCU 2+	Mainboard Firmware	Description
Cell Module	CCID1=8914800000	Each call attempt	X	X		First 10 characters of Circuit Card Interface Devices (CCID). Message value indicates the cell network that the CDMA cell phone is connected to at the time of the call.
Cell Module	CCID2=2805604979	Each call attempt	X	X		Last 11 characters of Circuit Card Interface Devices (CCID). Message value indicates the cell network that the CDMA cell phone is connected to at the time of the call.
Cell Module	CCSQ=28	Each call attempt	X	X		Message value indicates cell phone signal strength. This number ranges from 0 (weakest) to 31 (strongest) or 99 (no service).
Cell Module	CESN=FFFFFFFF	Each call attempt	X			Electronic serial number (ESN) of the cell module for a CDMA phone.
Cell Module	CHWV=0.00	Each call attempt	X	X		Message value indicates hardware version of cell phone.
Cell Module	CNET1=Verizon	Each call attempt	X	X		Cell phone carrier name.
Cell Module	CNET2=	Each call attempt	X	X		Remaining characters if cell phone carrier name is greater than 11 characters.
Cell Module	CNET3=	Each call attempt	X	X		Remaining characters if cell phone carrier name is greater than 22 characters.
Cell Module	CnktErr 1	Logged after failed call attempt	X	X		Ethernet UART Error: The UART IC (U119) failed, the cable to the modem is disconnected, or the modem is locked up.
Cell Module	CnktErr 2	Logged after failed call attempt	X	X		Modem Error - Could not communicate with the modem or could not connect to the Headend. Usually an indicator of a Headend IP network issue. May also occur when Headend is not ready to receive data or all phone lines are busy.
Cell Module	CnktErr 3	Logged after failed call attempt	X	X		Data Transfer Error - Modem connected to the NCC, but there was a problem transferring the data. This could be due to network latencies due to excessive traffic or multiple CRC communications errors.
Cell Module	CnktErr 4	Logged after failed call attempt	X	X		Command Error - Haven't received an NCC Command within the established Timeout period (usually 5 minutes).
Cell Module	CnktErr 5	Logged after failed call attempt	X	X		Socket Error (Connection Lost) - Connection to TCP/IP DCU Server has been lost.
Cell Module	CnktErr 6	Logged after failed call attempt	X	X		Socket Error (Cannot Create Socket) - Cannot create a socket. Usually, an invalid or nonexistent IP address or some other internal RTOS error.

Source	Message	Frequency	DCU 2	DCU 2+	Mainboard Firmware	Description
Cell Module	CnktErr 7	Logged after failed call attempt	X	X		Socket Error (Cannot Connect to Server) - Cannot connect to TCP/IP DCU Server (a socket connection to the machine had been accepted).
Cell Module	CnktErr 8	Logged after failed call attempt	X	X		Socket Error (Cannot Connect to Server) - Cannot connect to TCP/IP DCU Server (a socket connection to the machine had been accepted).
Cell Module	CnktErr 9	Logged after failed call attempt	X	X		Low Battery Error - Battery voltage has dropped dangerously low during the data transfer and DCU has entered a lower power standby mode.
Cell Module	CnktErr 10	Logged after failed call attempt	X	X		Cell Phone Reprogramming Failure - CDMA device Auto Activate process failed.
Cell Module	CnktErr 11	Logged after failed call attempt	X	X		Cell Phone Reprogramming Success - CDMA device Auto Activate process completed successfully.
Cell Module	CnktErr 12	Logged after failed call attempt	X	X		Cellular Device Socket Connection Lost.
Cell Module	CnktErr 13	Logged after failed call attempt	X	X		Cellular AT Command Sequence Failure.
Cell Module	CnktErr 14	Logged after failed call attempt	X	X		No Data Carrier (Typical Modem Equivalent).
Cell Module	CnktErr 15	Logged after failed call attempt	X	X		Busy (Typical Phone Equivalent).
Cell Module	CnktErr 16	Logged after failed call attempt	X	X		No Answer (Typical Phone Equivalent).
Cell Module	CnktErr 17	Logged after failed call attempt	X	X		Cellular device cannot establish socket connection.
Cell Module	CnktErr 18	Logged after failed call attempt	X	X		DNS Look-up Error: Failed to convert the connect machine name into a valid IP Address. Connecting to AcaraONE headend requires IP address format (rather than Domain Name Server format).
Cell Module	CnktErr 19	Logged after failed call attempt	X	X		Unknown Error - Contact Aclara.
Cell Module	CnktErr 20	Logged after failed call attempt	X	X		User Abort Error: Call was manually aborted by user pressing CTRL+A.

Source	Message	Frequency	DCU 2	DCU 2+	Mainboard Firmware	Description
Cell Module	CnktErr 21	Logged after failed call attempt	X	X		TCP/IP Stack Error - TCP/IP connection could not be made since the InterNiche TCP/IP stack is not running yet. Can occur when call attempted immediately after reset with DHCP enabled. Also could indicate connectivity issue.
Cell Module	CnktErr 22	Logged after failed call attempt	X	X		Ethernet Link Error: Physical hardware connection is broken or missing.
Cell Module	CnktErr 23	Logged after failed call attempt	X	X		Cellular Coverage Error.
Cell Module	CnktErr 24	Logged after failed call attempt	X	X		Point-To-Point Protocol Connection Error.
Cell Module	CnktErr 25	Logged after failed call attempt	X	X		Optional RF SHUTOFF Switch preventing any cellular or 450-470MHz transmissions.
Cell Module	CnktErr 26	Logged after failed call attempt	X	X		Cell module failed to register with cell network. Can be from no/not activated SIM card.
Cell Module	CnktErr 27	Logged after failed call attempt	X	X		Cell module denied registration on cell network. Can be from no/not activated SIM card.
Cell Module	CnktErr 28	Logged after failed call attempt	X	X		Cell Module Registration Unknown Issue. Can occur if SIM card not installed.
Cell Module	CnktErr 29	Logged after failed call attempt	X	X		Cell Module Registration Roaming Issue.
Cell Module	CnktErr 30	Logged after failed call attempt	X	X		Data Carrier Detect Signal Lost and Cellular module restarts.
Cell Module	CnktErr 31	Logged after failed call attempt	X	X		Send Records Error: Records not transferred to headend.
Cell Module	CnktErr 32	Logged after failed call attempt	X	X		Data Error: Socket Connection not active for 5 minutes. Cellular module restarts to recover. Error declared when DCU times out because no headend messages received for last 5 minutes.
Cell Module	CnktErr 33	Logged after failed call attempt	X	X		Data Carrier Detect Signal Lost and Cellular module restarts.

Source	Message	Frequency	DCU 2	DCU 2+	Mainboard Firmware	Description
Cell Module	CnktErr 34	Logged after failed call attempt	X		2.84	Cellular Always On Mode Interruption: Active call aborted because Always on mode configuration changes.
Cell Module	CnktErr 35				2.86	Cellular Module Busy Booting Linux OS: Module unable to execute commands while booting.
Cell Module	CnktErr 36				2.86	Generated when +CME ERROR: <err> is received in response to an AT command. Last three characters "xxx" denote the error code <err>. Available only when cell verbose mode is enabled. Lookup codes in Telit User Manual.
Cell Module	CNUM=13143419089	Each call attempt	X	X		Message value indicates phone number of the cell phone module.
Cell Module	ConnectFail!		X	X		Error generated after the 18th DCU call attempt fails.
Cell Module	COPS= 310410	Each call attempt	X			Roam settings for Wavecom Q2426BQM phone Message value indicates the cell network that cell phone is connected to at the time of the call. [The Messages are sent with each call attempt]
Cell Module	CPRL=1024	Each call attempt	X			PRL (Preferred Roaming List) version information for currently selected NAM (Number Assignment Module). Message value indicates PRL (Preferred Roaming List) version in a CDMA phone module.
Cell Module	CSID=21	Each call attempt	X			System Identification Number for CDMA phones. 0-32767: The mobile station is registered with the system indicated; 99999: not registered
Cell Module	CSWV=17.01.571	Each call attempt	X	X		Message value indicates firmware revision of cell phone module. [These messages are sent following a reset and with the transmission of test records from the DCU].
Cell Module	IMEI1=35323806	Each call attempt	X	X		First 8 characters of 15 character IMEI device identifier.
Cell Module	IMEI2=4053332	Each call attempt	X	X		Last 7 characters of 15 character IMEI device identifier.
Cell Module	MEID1=35323806	Each call attempt	X			First 8 characters of 14 characters of Mobile Equipment Identifier (MEID) for GSM devices. MEID replaced CDMA ESNs
Cell Module	MEID2=405333	Each call attempt	X			Last 6 characters of 14 characters of Mobile Equipment Identifier (MEID)
Cell Module	RSRP	Reconnection	X	X	2.84	Reference Signal Received Power; only available when cell verbose mode is enabled.
Cell Module	RSRQ	Reconnection	X	X	2.84	Reference Signal Received Quality; only available when cell verbose mode is enabled.

Source	Message	Frequency	DCU 2	DCU 2+	Mainboard Firmware	Description
Cell Module	TAQ	Reconnection	X	X	2.84	Tracking Area Code; only available when cell verbose mode is enabled.
Cell Module	ID	Reconnection	X	X	2.84	Cell Identifier; only available when cell verbose mode is enabled.
Cell Module	EARFCN	Reconnection	X	X	2.84	E-UTRA Assigned Radio Channel; only available when cell verbose mode is enabled.
Cell Module	PWR	Reconnection	X	X	2.84	Received signal strength in dBm; for serving cell in UMTS network this is not available during a call, and is displayed as 0; only available when cell verbose mode is enabled.
Cell Module	DRX	Reconnection	X	X	2.84	Discontinuous reception cycle length; only available when cell verbose mode is enabled.
Cell Module	PRE_BER=7	On Reset	X	X	2.84	Bit error rate before registration is confirmed. Data is brought back on next successful call even if registration fails which can be used in troubleshooting connection failures. See BER for details.
Cell Module	PRE_CCSQ=-51	On Reset	X	X	2.84	Reported RSSI value before AT+CGREG command is sent out. Value may not be from the carrier you want to register on. (data is brought back even if registration failed) 0 - (-113) dBm or less 1 - (-111) dBm 2...30 - (-109) dBm..(-53)dBm / 2 dBm per step 31 - (-51)dBm or greater 99 - not known or not detectable
Cell Module	RFSTS[i]=311 480	On Reset	X	X		Only available when cell verbose mode is enabled RFSTS reads current network status [1] <PLMN> - Country code and operator code(MCC, MNC) [2] <EARFCN> - E-UTRA Assigned Radio Channel [3] <RSRP> - Reference Signal Received Power [4] <RSSI> - Received Signal Strength Indication [5] <RSRQ> - Reference Signal Received Quality [6] <TAC> - Tracking Area Code [7] <RAC> - Routing Area Code [8] <TXPWR> - Tx Power (In traffic only) [9] <DRX> - Discontinuous reception cycle Length (cycle length in ms) [10] <MM> - Mobility Management state (for debug purpose only) [11] <RRC> - Radio Resource state (for debug purpose only) [12] <CID> - Cell ID [13] <IMSI> - International Mobile Station ID [14] <SD> - Service Domain [15] <ABND> - Active Band 1..63 [16] <SINR> - Signal-to-Interference plus Noise Ratio (range 0-250)

Source	Message	Frequency	DCU 2	DCU 2+	Mainboard Firmware	Description
H-Board	HBOARD_NO_REPLY	Event	X	X	2.8	H-board response timeout, only available in DCU 2 when using the 9985 power board.
Main Board	BackhaulSwitchTo=Next Backhaul, Reason	Event		X	03.20.0012	Next Backhaul: 0: Eth/Fib 1: Cellular Reason: 0: Manual return to main backhaul 1: Automatic return to main backhaul 2: main backhaul changed 3: Heartbeat timeout 4: Maximum attempts on a backhaul are over
Main Board	Bad Alarm!		X	X		Indicates that the alarm settings have been corrupted. Usually caused by low or dead Lithium battery (BT101) on motherboard or a firmware bug. DCU will reset in an attempt to recover.
Main Board	BATTERY_CHARGE_OK	Event		X	03.10.0012	Occurs when DCU is running and the battery is charged over the threshold value.
Main Board	BkBattFail	On Reset	X	X		Lithium battery on DCU motherboard failed to keep records intact in the buffer memory.
Main Board	CONSOLE_ACCEPTED	Event	X	X		Correct console passphrase entered.
Main Board	CONSOLE_DENIED	Event	X	X		Incorrect console passphrase entered.
Main Board	CONSOLE_LOGOUT	Event	X	X		User logs out of console by entering "ctrl + L" using DCU control port.
Main Board	CONSOLE_RELEASED	Event	X	X		Console Menu Lockout Expiration: Console released after 10 minute lockout period expires. Control port locked when max login attempts exceeded.
Main Board	CONSOLE_TIMEOUT	Event	X	X		Console Menu Timeout: Timeout occurs after a specified time without any user input.
Main Board	DCU_RF_TX_OFF	Event	X	X		Sent when transitioning to RF disabled state.
Main Board	DCU_RF_TX_ON	Event	X	X		Sent after transitioning to RF enabled state.
Main Board	DCUDOOR_CLOSED	Event	X	X		Indicates door is properly closed.
Main Board	DCUDOOR_NOTWIRED	Event	X	X		Alarm record to headend if DCU door is not installed.
Main Board	DCUDOOR_OPENED	Event	X	X		Indicates the door is opened.
Main Board	DCUDOOR_STILLOPEN	Event	X	X		Indicates door has been open for 12 hours.
Main Board	DCUDOOR_WIRED	Event	X	X		Alarm record to headend if DCU door is installed.
Main Board	GNSSCount=11	Hourly		X		Number of Global Navigation Satellite System (GNSS) Satellites Acquired. Minimum of 1 satellite required for time and minimum of 3 satellites required for reasonable device location information.

Source	Message	Frequency	DCU 2	DCU 2+	Mainboard Firmware	Description
Main Board	HEIGHTMSL=187	On Reset		X		GNSS height above mean sea level of DCU installation site in meters.
Main Board	LAT=43.049600	On Reset	X	X		For DCU2: Latitude (degrees) entered by installer via menu For DCU2+: Latitude (degrees) of GNSS Device Antenna reported by GNSS device
Main Board	LON=-76.150300	On Reset	X	X		For DCU2: Longitude (degrees) entered by installer via menu For DCU2+: Longitude (degrees) of GNSS Device Antenna reported by GNSS device
Main Board	LOW_PWR_SUSPEND	Event	X	X	03.10.0012	Power Management System places system in low power mode when 12VDC Lead Acid Battery State of Charge (SoC) drops below specified threshold for location and time of year. While in low power mode, system will: <ul style="list-style-type: none"> <li>• check SoC threshold every hour</li> <li>• sends STAR time syncs every day</li> <li>• wakeup once every 72 hours to provide 6 hours of normal operation</li> </ul>
Main Board	MAC0=00:19:2B	On Reset	X	X		First three octets of MAC address (Organizationally Unique Identifier) Only present for Ethernet boards.
Main Board	MAC1=00:13:9F	On Reset	X	X		Last three octets of MAC address (Network Interface Controller specific) Only present for Ethernet boards.
Main Board	MBFW=03.00.0002	On Reset	X	X		Motherboard Firmware Version identifier. Format is VV.RR.bbbb where VV is firmware Version number, RR is firmware revision number, and bbbb is build number.
Main Board	MTU_FOTA_END=	Event	X	X		MTU Firmware-Over-The-Air (FOTA) Ended.
Main Board	NoData!		X	X		This message occurs when the DCU connects with an empty data buffer. This normally indicates that the communication with the NCC was dropped after receiving the clear command but before any records have been transferred.
Main Board	PCount=35272	On Change		X		Number of DCU records purged to remove outdated records or make room for new/higher priority records The DCU will purges electric records first. Gas/water (STAR) records will then be purged once memory is full.
Main Board	REBOOT_BATT_CHRG	Event		X	03.10.0012	Power Management System transitions DCU from low power mode to normal operation because adequate Solar or AC power is available to operate system while charging 12VDC Lead Acid battery even while battery below SoC threshold.
Main Board	REBOOT_BATT_OK	Event		X	03.10.0012	Power Management System transitions DCU from low power mode to normal operation because 12VDC Lead Acid battery SoC above SoC threshold.



Source	Message	Frequency	DCU 2	DCU 2+	Mainboard Firmware	Description
Main Board	REBOOT_WAKEUP	Event		X	03.10.0012	Power Management System Low Power Wakeup Service. While in low power mode, system will: <ul style="list-style-type: none"> <li>sends 11 STAR time syncs every day starting at 9:38.25 and ending at 9:38:35</li> <li>wakeup once every 72 hours to provide 6 hours of normal operation (transfer endpoint records to headend and relay headend commands to endpoints)</li> </ul>
Main Board	ResetCode=M4	On Reset		X		Reset code indicates the reason for the last mainboard reset: M0 = Mainboard HW Reset M1 = Backhaul WFR (used after FW downloads) M2 = DCU-to-DCU reset command M3 = Watchdog timeout M4 = Recovery from power management FW shutdown M5 = Power Supply forced shutdown (HW) M6 = Reset button on mainboard M7 = Reset command via Control Port interface M8 = SPI port timeout M9 = Restore config defaults via Control Port interface M10 = FW integrity check failure (e.g., bad values of arrays, etc.) X1 = Transceiver not clearing interrupt line to MB X2 = Transceiver reset event X3 = Transceiver disconnect watchdog
Main Board	StackOFLO=11	Event	X	X		Indicates task that caused the stack to overflow.
Main Board	SystemRes!!	On Reset	X	X		Indicates that the DCU was reset (rebooted). This happens following firmware upgrades and other maintenance procedures and can also be caused by an internal software watchdog.
Main Board	TstRec		X	X		Enumerated test record that have been generated and sent from the corresponding DCU during the installation confirmation process. Test records must be generated by the installer via the local menu.
Main Board	UTCaccuracy=12	Hourly		X		UTC Time Accuracy in nanoseconds.
Power Supply	BATTChem=Lead Acid,6	On Reset		X		Battery Chemistry and Cells: For standard Aclara lead acid battery the response should be "Lead Acid".
Power Supply	BATTCount=1	Daily		X	03.10.0012	Battery Count: The number of 12VDC batteries connected in parallel. For current Aclara DCU 2+ the count should be 1. Incorrect setting of this value will cause incorrect State-of-Charge values.
Power Supply	BATTLV=11.25	Daily	X			Battery Size in Amp-Hours: The standard Aclara DCU2 battery is 31AHrs and the standard DCU2+ battery is 41AHrs. Incorrect setting of this value will cause incorrect State-of-Charge values.

Source	Message	Frequency	DCU 2	DCU 2+	Mainboard Firmware	Description
Power Supply	BATTSize=41	Daily		X	03.10.0012	Battery Size in Amp-Hours: The standard Acala DCU2 battery is 31AHrs and the standard DCU 2+ battery is 41AHrs. Incorrect setting of this value will cause incorrect State-of-Charge values.
Power Supply	BATTSR=0.004	Daily		X		Battery Series Resistance. A measurement to evaluate battery health. This value is currently in beta and may be dropped/modified in the future. Accurate BSR requires a high discharge current that is currently not activated in the relatively low power DCUs. At this time the Power Management System provides a much better estimate of battery health.
Power Supply	BATTTemp=-011.25C	Hourly		X		Battery Temperature of the 12VDC battery inside the outer cabinet. The battery temperature should be approximately the equal to the ambient outside temperature plus some additional temperature rise associated with solar loading and inner electronics enclosure. This value is available in the DCU 2+ or in DCUs where a thermistor is installed.
Power Supply	BATTUV=12.36	Hourly	X			Battery voltage reported at the top of the hour when load is removed. The reading indicates a instantaneous charge of the battery
Power Supply	CHARGEConfig=JEITA	Daily, on charge			Deprecated	Current charge algorithm for determining charge configuration (from battey chemistry and LTC4015 Register 0x29) which controls the charge voltage target: JEITA = indicates LTC4015 JEITA temperature qualified algorithm with C/x charge termination disabled (lithium chemistry & LTC4015 Register 0x29 bit 0: en_jeita = 1 & LTC4015 Register 0x29 bit 2: en_c_over_x_term = 0) JEITA_C/x = indicates LTC4015 JEITA temperature qualified algorithm with C/x charge termination enabled (lithium chemistry & LTC4015 Register 0x29 bit 0: en_jeita = 1 & LTC4015 Register 0x29 bit 2: en_c_over_x_term = 1)
Power Supply	CHARGEConfig=TempComp	Daily, charge		X	Deprecate d	Current charge algorithm for determining charge configuration (from LTC4015 Register 0x29) which controls the charge voltage target: TempComp = indicates LTC4015 temperature compensated charge voltage that is used when battery temperature < 45C (lead-acid battery chemistry & LTC4015 Register 0x29 bit 1: en_lead_acid_temp_comp = 1) Fixed = indicates a fixed voltage setting that is used when battery temperature >= 45C (lead-acid battery chemistry & LTC4015 Register 0x29 bit 1: en_lead_acid_temp_comp = 0)

Source	Message	Frequency	DCU 2	DCU 2+	Mainboard Firmware	Description
Power Supply	CHARGEError=BattShort	Daily (if condition present)		X		<p>DCU2+ Battery Charger Error: errors include:</p> <ul style="list-style-type: none"> <li>BattMissing: No battery detected. Check cables</li> <li>BattShort: Battery shorted. Check cables and circuits</li> <li>CellCount: Unexpected battery cell count value</li> <li>Thermal: Power Board LTC4015 microprocessor in thermal shutdown protection mode due to an excessively high die temperature.</li> <li>HighVoltageInput: Power Board LTC4015 microprocessor in thermal shutdown protection mode due to an input voltage above its protection shutdown threshold of approximately 38.6V (typical).</li> <li>LowVoltageInput: Power Board input voltage not high enough to allow battery charging</li> <li>HighNTCRatio = Thermistor may be absent, damaged, or cable pinched.</li> <li>LowNTCRatio = Thermistor may be faulty or wire shorted.</li> </ul>
Power Supply	CHARGEmppt=Enabled	Daily (if condition present)				Main board throttling of input current (0x15 or 0x1A) due to temp. Otherwise maximum power point tracking is turned on (needed for solar). Status is read (from LTC4015 Register 0x39 bit 11: mppt_en_pin).
Power Supply	CHARGEState=On,Absorb/CC	Daily, On Change		X		<p>DCU2+ Charging State:</p> <ul style="list-style-type: none"> <li>On,Equalize - Lead-acid equalization charge state</li> <li>On,Absorb = Absorb charge state. Expected until battery about 80% charged</li> <li>On,CC_CV = Constant-current constant-voltage state. Expected when battery 80% to 95% charged</li> <li>Off,Suspended = Battery charging suspended. Might occur due to extreme air temperatures</li> <li>Off,Error = Battery missing or shorted</li> </ul>
Power Supply	FullPwrCompsumption=4000	Daily		X	03.10.0012	Normal Operation Average Power Consumption in milliWatts. A standard DCU 2+ configuration typically consumes about 4000mW.
Power Supply	HOcm=AC/DC	On Change	X	X		<p>Charging Mode:</p> <p>AC/DC - AC source detected/selected          SOLAR - Solar source detected/selected          LUNAR - Lunar source selected (DCU2 only)          NOPWR - no source detected (DCU2+ only)          ERROR - unsupported configuration (DCU2+ only)</p> <p>Note that DCU2 is manually set in the console while DCU 2+ is autodetected.</p>

Source	Message	Frequency	DCU 2	DCU 2+	Mainboard Firmware	Description
Power Supply	HOHW=F	On Reset	X	X		Provides the DCU 2 power board firmware revision. Always reads 0 for DCU 2+.
Power Supply	HOSN=	On Reset	X	X		Power Supply Serial Number. Only valid for DCU2s. For DCU2+, 0 value returned.
Power Supply	INPUTCur=1.36	Hourly		X		Current in amps (IIN) provided to DCU 2+ power board.
Power Supply	INPUTV=12.36	Hourly		X		Battery Voltage (Vbat) for DCU 2+.
Power Supply	LowPwrCompsumption=0450	Daily		X	03.10.0012	Low Power Mode Average Power Consumption in milliWatts. A standard DCU 2+ configuration typically consumes about 450mW in low power mode.
Power Supply	nonWinterThresholdFloor=20%	Daily		X	03.10.0012	Minimum SoC Threshold Setting for Non-Winter Season. This value sets a battery minimum State-of-Charge level that the system can operate normally. This value can override the Power Management System. For this reason, recommend this value be set to less than 20% SoC.
Power Supply	nonWinterThresholdSoc=25%	Daily		X	03.10.0012	Current SoC Threshold for Non-Winter Season: Threshold at which the DCU 2+ will enter low power mode. This value will vary based on DCU 2+ configuration. This is value is automatically calculated based on GPS-obtained coordinates.
Power Supply	SoC=72.1%,8.207,6.521	Hourly			X	Battery State-of-Charge Estimate: Battery state of charge calculated by the Power Management System. The value is reported hourly. Valid range of 0 to 100%. For AC systems, the SoC should be steady and above 89%. For solar DCU 2+, the SoC will increase when sunlight available and will discharge when sunshine not available.
Power Supply	SPSCCur=1.36	Hourly	X			This message normally occurs hourly (except at midnight GMT). The message value indicates the battery charging current sampled the previous hour.
Power Supply	SYSTEMV=12.00	Hourly		X		Regulated System Voltage (Vsys) provided to DCU 2+ electronics.
Power Supply	Temp=-011.25C	Hourly	X			This message occurs hourly providing the internal DCU 2 temperature in degrees Celsius sampled the previous hour.
Power Supply	Temp=-011.25C	Hourly		X		DCU 2+ power board charging chip die temperature in Celsius. Maximum rated operating junction temperature for power board charging chip die temperature is 125C. Example observations show: no battery connected -15-20C rise over ambient, solar input current of 0.5A or AC float charge -20-25C rise over ambient, AC full charge current -35-40C rise over ambient.

Source	Message	Frequency	DCU 2	DCU 2+	Mainboard Firmware	Description
Power Supply	WakeupDuration=0240	Daily		X	03.10.0012	Wakeup Service Duration: The duration that the DCU 2+ will stay in normal operating mode. The default is 360 minutes (6 hours). For example, in low power mode the DCU 2+ will wakeup for 6 hours every 72 hours. These default values should never be adjusted without Aclara Engineering direction.
Power Supply	WakeupPeriod=4320	Daily		X	03.10.0012	Wakeup Period: The maximum amount of time between service when operating in low power mode. The default is 4320 minutes (72 hours). Every 72 hours, the DCU will wake up and operation in normal operation mode for the duration of the service time. This default value should never be adjusted without Aclara Engineering direction.
Power Supply	WakeupStart=0360	Daily		X	03.10.0012	Time of Day to Begin Wakeup Service: Local time of day that the DCU will wake up during the wakeup service period. Default is 1320 (10pm Local time). The DCU estimates local time from longitude so the local wakeup time may be off by an hour. This default value should never be adjusted without Aclara Engineering direction.
Power Supply	WinterEndDay= 42	Daily		X	03.10.0012	Winter End Day: Desdonsl date when the SoC threshold will revert to the Non-Winter threshold settings. This is value is automatically calculated based on GPS-obtained coordinates.
Power Supply	WinterStartDay=325	Daily		X	03.10.0012	Winter Start Day: Day of the year in which the Winter State-of-Charge (SoC) threshold will become active. This is value is automatically calculated based on GPS-obtained coordinates.
Power Supply	WinterThresholdFloor=20%	Daily		X	03.10.0012	Minimum SoC Threshold Setting for Winter Season. This value sets a battery minimum State-of-Charge level that the system can operate normally. This value can override the Power Management System. For this reason, recommend this value be set to less than 20% SoC.
Power Supply	WinterThresholdSoc=42%	Daily		X	03.10.0012	Current SoC Threshold for Winter: Threshold at which the DCU 2+ will enter low power mode. This value will vary based on DCU 2+ configuration. This is value is automatically calculated based on GPS-obtained coordinates.
Transceiver	AvRSSI=-127.6,1920	Hourly	X	X		Method for reporting Average Background RSSI. A value of 55 is used as an error code not a real measurement. The first value provides the measurement, the second value is used to denote the channel when coming from a T-Board.
Transceiver	GxHW		X			Message value indicates hardware revision of transceiver board type G. X will be a value 1-4 to indicate slot number. These messages are sent following a reset and with the transmission of test records from the DCU.

Source	Message	Frequency	DCU 2	DCU 2+	Mainboard Firmware	Description
Transceiver	GxSN		X			Message value indicates serial number of transceiver board type G. X will be a value 1-4 to indicate slot number. These messages are sent following a reset and with the transmission of test records from the DCU.
Transceiver	JxBR		X			Message value indicates baud rate of transceiver board type J. X will be a value 1-4 to indicate slot number. These messages are sent following a reset and with the transmission of test records from the DCU.
Transceiver	JxDM		X			Message value indicates demodulator mode (linear or correlated) of transceiver board type J. X will be a value 1-4 to indicate slot number. These messages are sent following a reset and with the transmission of test records from the DCU.
Transceiver	JxFW		X			Message value indicates firmware revision of transceiver board type J. X will be a value 1-4 to indicate slot number. These messages are sent following a reset and with the transmission of test records from the DCU.
Transceiver	JxHW		X			Message value indicates hardware revision of transceiver board type J. X will be a value 1-4 to indicate slot number. These messages are sent following a reset and with the transmission of test records from the DCU.
Transceiver	JxSN		X			Message value indicates serial number of transceiver board type J. X will be a value 1-4 to indicate slot number. These messages are sent following a reset and with the transmission of test records from the DCU.
Transceiver	LOLx					Loss of Lock indicates that the receiver has temporarily been off the programmed frequency. This can be caused by a faulty receiver, a lightning strike, or interference on the programmed or adjacent channels. The message value indicates the transceiver slot (1-4) that had the error.
Transceiver	PkRSSI=-127.0,1920	Hourly	X	X		A value of 55 is used as an error code, not a real measurement. The first value provides the measurement. The second value is used to denote the channel when coming from a T-Board.
Transceiver	SSC_CH0 Overrun	Event	X	X		SSC channel 0 overrun. Internal error code for engineering diagnosis.
Transceiver	SSC_CH1 Overrun	Event	X	X		SSC channel 1 overrun. Internal error code for engineering diagnosis.
Transceiver	SSC_CH2 Overrun	Event	X	X		SSC channel 2 overrun. Internal error code for engineering diagnosis.
Transceiver	T1DISCONNECTED	Event	X			Synchronous serial channel 0 timeout; T-board 1 disconnected.
Transceiver	T1FW=01.02.0014	On Reset				Firmware Version loaded on T-Board 1.

Source	Message	Frequency	DCU 2	DCU 2+	Mainboard Firmware	Description
Transceiver	T1HW=B	On Reset				Hardware Type of T-Board 1.
Transceiver	T1SN=0001000aa6	On Reset				Serial Number of T-Board 1.
Transceiver	T2DISCONNECTED	Event	X			Synchronous serial channel 0 timeout; T-board 2 disconnected.
Transceiver	T2FW=01.02.0014	On Reset	X	X		Firmware version loaded on T-Board 2. Format is VV.RR.bbbb where VV is firmware version number. RR is firmware revision number, and bbbb is build number.
Transceiver	T2HW=B	On Reset	X	X		Hardware Type of T-Board 2.
Transceiver	T2SN=0001000aa6	On Reset	X	X		Serial Number of T-Board 2.
Transceiver	T3DISCONNECTED	Event	X			Synchronous serial channel 0 timeout; T-Board 3 disconnected.
Transceiver	T3FW=99.50.0020	On Reset		X		Slot 3 T-Board Firmware Version identifier. Format is VV.RR.bbbb where VV is firmware Version number. RR is firmware revision number, and bbbb is build number.
Transceiver	T3HW=B	On Reset		X		Hardware type of T-Board 3.
Transceiver	T3SN=00010156fb	On Reset		X		Serial number of T-Board 3.
Transceiver	TB_UNDETECTED	Event	X			T-Board undetected. DCU is reset after this.
WiFi Board	WFSW=6.6.0.0	On Reset				WiFi version string.





# Index

## A

- Aclara Connect 9
- Aclara University 9
- AclaraONE 43
- AclaraONE Headend 11
- Administrator Commands 26
- Advanced Menu 29
- Alarm Menu 27
- Antenna 49
- Antenna Clearance 33
- Antenna Pattern Test 53
- APN 19
- AWN 19

## B

- Backplane 51
- Baseline Data 53
- Battery Protection 14

## C

- Calibration 57
- Cellular Board 47
- Coaxial Cable Insertion Loss 57
- Colocation Assurance 32
- Commission the DCU 20
- Connect to the Main Board 19

## D

- Data Collector Unit 11
- Data Collector Unit (DCU) 12
- DCU 2 15
- DCU 2+ 14
- DCU Console Menu 24
- DCU II 12
- DCU Main Processor Board 44
- Distance to Fault (Coaxial Cable) 57

## E

- Earth Ground 59
- Earth Ground Resistance 32
- Endpoint 11
- ESD Caution 8
- Ethernet 12

## F

- Failover Backhaul 12, 13
- Fall Hazard When Working at Elevation 7
- FCC/IC Compliance 4
- FCC/IC RF Exposure Guide 4

- Fiber 13
- Field Calibration Procedure 5
- Field Data 54
- Functional Testing 59

## G

- General Observations 33
- Global Commands 25
- Global Positioning System 48
- Global Positioning System (GPS) 14
- GNSS 30

## I

- Inspect Antenna Clearance 8
- Inspect the Battery 32
- Inspect the Lock 32
- Inspect the Mounting 31
- Inspecting the Site 31
- Interferer Test 55

## L

- Label Inspection 33
- LTE 12

## M

- Main Processor Board with Ethernet 45
- Main Processor Board without Ethernet 46
- Maintenance 31
- Manufacturing Menu 27
- Meter Transmission Unit 11
- MTU Menu 27

## N

- Network Control Computer 11

## P

- Performance Testing 60
- Pole-Mount Installations 7
- Power Management 18
- Power Supply Board 50
- Power Supply Debug Menu 28
- Product Specifications 1

## R

- Records Menu 28
- Repairing the DCU 36
- Replacement Parts 8
- Replacing a Fuse 36
- Replacing a Main Board 40
- Replacing the Battery 36

Replacing the Cellular Antenna 37  
Required Grounding 7  
Return Loss (Antenna System) 58  
Return Loss on the Coaxial Cable 57  
Returning Product 9  
RF Exposure Hazard 7  
RF Sweeps 57  
Rooftop-Specific Hazards 8  
Routine Checks 35  
RSSI Measurement 56

## **S**

Safety Guidelines 6  
Servicing the DCU 34  
Shock Hazard Warning 6  
Solar 13  
Spectrum Analysis 59  
Support 9  
Survey the Site 31  
System Prerequisites 13

## **T**

Technical Support 9  
Test Analysis 58  
Testing the Backhaul 59  
Testing the Coax and Antenna 57  
Testing the DCU 53  
Tools & Equipment 35  
Tools Required 19  
Transceiver Board Options 13  
Transceiver Debug Menu 29  
Transceiver Menu 28  
Troubleshooting 43, 44

## **V**

Visual Check 43