



Electromagnetic Compatibility Test Report

Tests Performed on an Aclara Technologies
 Pole Sensor Transceiver, Model PSC7231PSA
 Radiometrics Document RP-9571C



Product Detail:

FCC ID: LLB20200005
 IC: 4546A-20200005
 Equipment type: Low power 2.4 GHz transceiver

Test Standards:

US CFR Title 47, Chapter I, FCC Part 15 Subpart C
 FCC Part 15 CFR Title 47: 2020
 Canada ISED; RSS-210, Issue 10: 2019 as required for Category I Equipment
 IC RSS-GEN Issue 5: 2018

This report concerns: Original Grant for Certification
 FCC Part 15.249

Tests Performed For:

Aclara Technologies
 77 West port Plaza
 Saint Louis, MO 63146-3126

Test Facility:

Radiometrics Midwest Corporation
 12 Devonwood Avenue
 Romeoville, IL 60446-1349
 (815) 293-0772

Test Date(s):

January 19 to February 4, 2022

Document RP-9571C Revisions:

Rev.	Issue Date	Revised By
0	March 17, 2022	



Table of Contents

1.0 ADMINISTRATIVE DATA.....	3
2.0 TEST SUMMARY AND RESULTS	3
2.1 RF Exposure Compliance Requirements	4
3.0 EQUIPMENT UNDER TEST (EUT) DETAILS	4
3.1 EUT Description.....	4
3.1.1 FCC Section 15.203 & RSS-GEN Antenna Requirements.....	4
4.0 TESTED SYSTEM DETAILS.....	4
4.1 Tested System Configuration.....	4
4.2 EUT Operating Modes	4
4.3 Special Accessories.....	5
4.4 Equipment Modifications	5
5.0 TEST SPECIFICATIONS	5
6.0 TEST PROCEDURE DOCUMENTS.....	5
7.0 RADIOMETRICS' TEST FACILITIES	5
8.0 DEVIATIONS AND EXCLUSIONS FROM THE TEST SPECIFICATIONS.....	6
9.0 CERTIFICATION.....	6
10.0 TEST EQUIPMENT TABLE.....	6
11.0 TEST SECTIONS.....	7
11.1 Radiated RF Emissions.....	7
11.1.1 Field Strength Calculation.....	7
11.1.2 Duty Cycle.....	8
11.1.3 Radiated Emissions Test Results	8
11.2 Occupied Bandwidth Data.....	13
11.3 Unintentional Emissions (Receive Mode).....	16
11.3.1 Measurement Instrumentation Uncertainty	18
12.0 REVISION HISTORY	18

Notice: This report must not be reproduced (except in full) without the written approval of Radiometrics Midwest Corporation.

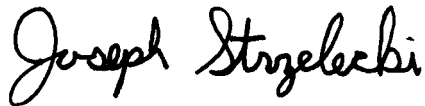

1.0 ADMINISTRATIVE DATA

<i>Equipment Under Test:</i> An Aclara Technologies, Pole Sensor Model: PSC7231PSA Serial Number: RMC6 This will be referred to as the EUT in this Report	
<i>Date EUT Received at Radiometrics:</i> January 3, 2022	<i>Test Date(s):</i> January 19 to February 4, 2022
<i>Test Report Written and Authorized By:</i> Joseph Strzelecki Senior EMC Engineer	<i>Test Witnessed By:</i> The tests were not witnessed by personnel from Aclara Technologies.
<i>Radiometrics' Personnel Responsible for Test:</i>  03/17/2022 Date Joseph Strzelecki Senior EMC Engineer NARTE EMC-000877-NE Chris D'Alessio EMC Technician	<i>EUT Checked By:</i> Joseph Strzelecki Radiometrics

2.0 TEST SUMMARY AND RESULTS

The EUT (Equipment Under Test) is a Pole Sensor, Model PSC7231PSA, manufactured by Aclara Technologies. The detailed test results are presented in a separate section. The following is a summary of the test results.

Emissions Tests Results

Environmental Phenomena	Frequency Range	Basic Standard	Test Result
RF Radiated Emissions	30-25,000 MHz	RSS-210 & FCC Part 15	Pass
Occupied Bandwidth Test	Fundamental Freq.	RSS-210 & FCC Part 15	Pass

IEC 17025 Decision Rule:

The declaration of pass or fail is based on the specifications listed above. The declaration of pass or fail did not consider measurement uncertainty.



2.1 RF Exposure Compliance Requirements

Since the power output is less than 10 mW, the EUT meets the FCC requirement for RF exposure and it is exempt from RSS-102 SAR and RF exposure evaluations. There are no power level adjustments available to the end user. The antenna is permanently attached. The detailed calculations for RF Exposure are presented in a separate document.

3.0 EQUIPMENT UNDER TEST (EUT) DETAILS

3.1 EUT Description

The EUT is a Pole Sensor, Model PSC7231PSA with a 2.4 GHz radio, manufactured by Aclara Technologies. The EUT was in good working condition during the tests, with no known defects.

3.1.1 FCC Section 15.203 & RSS-GEN Antenna Requirements

The antenna is permanently attached to the printed circuit board. The antenna is internal to the EUT and it is not readily available to be modified by the end user. Therefore, it meets the 15.203 Requirements.

4.0 TESTED SYSTEM DETAILS

4.1 Tested System Configuration

The system was configured for testing in a typical fashion. The EUT was placed on an 80-cm or 150 cm high, nonconductive test stand. The testing was performed in conditions as close as possible to installed conditions. Wiring was consistent with manufacturer's recommendations. The EUT was tested as a stand-alone device. Power was supplied with a new battery.

Tested System Configuration List

Item	Description	Type*	Manufacturer	Model Number	Serial Number
1	Pole Sensor	E	Aclara Technologies	PSC7231PSA	RMC7
2	Pole Sensor	E	Aclara Technologies	PSC7231PSA	RMC8

* Type: E = EUT

Type of modulation including the bit rate and symbol rate	2Mbit/s GFSK
Name and version of the test software used to exercise the device	Silicon Labs NCP Commander
Power settings used for the purpose of exercising the device	6.0dBm
Firmware number of the transmitter	Ver1.0.17

4.2 EUT Operating Modes

The transmit mode for all tests was continuous.

The EUT was in its normal GFSK modulation during the tests. It was tested as a stand-alone battery powered device, since that is the configuration in the final installation.



4.3 Special Accessories

No special accessories were used during the tests in order to achieve compliance.

4.4 Equipment Modifications

No modifications were made to the EUT at Radiometrics' test facility in order to comply with the standards listed in this report.

5.0 TEST SPECIFICATIONS

Document	Date	Title
FCC CFR Title 47	2022	Code of Federal Regulations Title 47, Chapter 1, Federal Communications Commission, Part 15 - Radio Frequency Devices
IC RSS-210 Issue 10	2019	Low Power Licence-Exempt Radiocommunication Devices (All Frequency Bands) Category I Equipment
IC RSS-Gen Issue 5	2019	General Requirements and Information for the Certification of Radiocommunication Equipment (RSS-Gen)

6.0 TEST PROCEDURE DOCUMENTS

The tests were performed using the procedures from the following specifications:

Document	Date	Title
ANSI C63.4-2014	2014	Methods of Measurement of Radio Noise Emissions from Low-Voltage Electrical and Electronic Equipment in the Range of 9 kHz to 40 GHz
ANSI C63.10-2013	2013	American National Standard for Testing Unlicensed Wireless Devices

7.0 RADIOMETRICS' TEST FACILITIES

The results of these tests were obtained at Radiometrics Midwest Corp. in Romeoville, Illinois, USA. Radiometrics is accredited by A2LA (American Association for Laboratory Accreditation) to conform to ISO/IEC 17025: 2017 "General Requirements for the Competence of Calibration and Testing Laboratories". Radiometrics' Lab Code is 121191 and Certification Number is 1495.01. Radiometrics' scope of accreditation includes all of the test methods listed herein. A copy of the accreditation can be accessed on our web site (www.radiomet.com). Radiometrics accreditation status can be verified at A2LA's web site (www.a2la2.org).

The following is a list of shielded enclosures located in Romeoville, Illinois used during the tests:

Chamber E: Is a custom-made anechoic chamber that measures 52' L X 30' W X 18' H. The walls and ceiling are fully lined with RF absorber. Pro-shield of Collinsville, Oklahoma manufactured the chamber. The floor has a 9' x 9' section of microwave absorber for testing above 1 GHz.

Test Station F: Is an area that measures 10' D X 12' W X 10' H. The floor and back wall are metal shielded. This area is used for conducted emissions measurements.

A separate ten-foot long, brass plated, steel ground rod attached via a 6-inch copper braid grounds each of the above chambers. Each enclosure is also equipped with low-pass power line filters.



The FCC has accepted these sites as test site number US1065. The FCC test site Registration Number is 732175. Details of the site characteristics are on file with the Industry Canada as site number IC 3124A with a CAB ID of US0224.

A complete list of the test equipment is provided herein. The calibration due dates are indicated on the equipment list. The equipment is calibrated in accordance to ANSI/NCSL Z540-1 with traceability to the National Institute of Standards and Technology (NIST).

8.0 DEVIATIONS AND EXCLUSIONS FROM THE TEST SPECIFICATIONS

There were no deviations or exclusions from the test specifications.

9.0 CERTIFICATION

Radiometrics Midwest Corporation certifies that the data contained herein was taken under conditions that meet or exceed the requirements of the test specification and the data contained herein was taken with calibrated test equipment. The results relate only to the EUT listed herein.

10.0 TEST EQUIPMENT TABLE

RMC ID	Manufacturer	Description	Model No.	Serial No.	Frequency Range	Cal Period	Cal Date
AMP-05	RMC/Celeritek	Pre-amplifier	MW110G	1001	1.0-12GHz	12 Mo.	01/04/22
AMP-20	Avantek	Pre-amplifier	SF8-0652	15221	8-18GHz	12 Mo	04/19/21
AMP-59	Amplitech	Pre-amplifier	APTMP44	AMP-59	18-26 GHz	12 Mo.	01/06/22
ANT-06	EMCO	Log-Periodic Ant.	3146	1248	200-1000MHz	24 Mo.	01/18/22
ANT-48	RMC	Std Gain Horn	HW2020	1001	18-26 GHz	36 Mo.	08/09/19
ANT-66	ETS-Lindgren	Horn Antenna	3115	62580	1.0-18GHz	24 Mo.	03/11/21
ANT-80	AH Systems	Bicon Antenna	SAS-540	294	20-330MHz	24 Mo.	01/05/21
HPF-06	Mini-Circuits	High Pass Filter	VHF-3800+	31035	3-11 GHz	24 Mo.	05/07/20
REC-11	HP / Agilent	Spectrum Analyzer	E7405A	US39110103	9Hz-26.5GHz	24 Mo	04/16/20
REC-20	HP / Agilent	Spectrum Analyzer	85460A/84562A	33330A00135 3410A00178	30Hz-6GHz	24 Mo.	08/18/21
REC-44	Agilent	Spectrum Analyzer	E4440A	US40420673	3Hz-26.5GHz	24 Mo.	02/25/20
THM-02	Fluke	Temp/Humid Meter	971	93490471	N/A	24 Mo.	11/13/20

Note: All calibrated equipment is subject to periodic checks.

Software Company	Test Software Name	Version	Applicable Tests
Radiometrics	RRECE11D	07.16.19	RF Radiated Emissions (FCC Part 15 & EN 55032)
Agilent	PSA/ESA-E/L/EMC	2.4.0.42	Bandwidth and screen shots



11.0 TEST SECTIONS

Radiated Emissions Field Strength Limits

Frequency Range (MHz)	Test Distance (meters)	Class B Limits	
		uV/m	dB(uV/m)
30 - 88	3	100	40.0
88 - 216	3	150	43.5
216 - 960	3	200	46.0
Above 960	3	500	54.0

The emission limits shown in the above table are based on measurements using a CISPR quasi-peak below 1000 MHz. Radiated emission limits above 1 GHz are based on measurements employing a peak and average detector.

11.1 Radiated RF Emissions

Radiated emission measurements were performed with linearly polarized broadband antennas. The results obtained with these antennas can be correlated with results obtained with a tuned dipole antenna. The radiated emission measurements were performed with a spectrum analyzer. The bandwidth used from 150 kHz to 30 MHz is 9 kHz and the bandwidth from 30 MHz to 1000 MHz is 120 kHz. Above 1 GHz, a 1 MHz bandwidth is used. A 10 dB linearity check is performed prior to start of testing in order to determine if an overload condition exists. Figure 4 herein lists the details of the test equipment used during radiated emissions tests.

In addition, a high pass filter was used to reduce the fundamental emission. High pass filters were not needed above 10 GHz, since the preamplifiers attenuated the fundamental emission. The EUT was rotated through three orthogonal axis as per 5.10.1 of ANSI C63.10 during the radiated tests.

Final radiated emissions measurements were performed inside of an anechoic chamber at a test distance of 3 meters. The anechoic chamber is designated as Chamber E. This Chamber meets the Site Attenuation requirements of ANSI C63.4 and CISPR 16-1. Chamber E is located at 12 Devonwood Ave. Romeoville, Illinois EMI test lab.

The entire frequency range from 30 to 25,000 MHz was slowly scanned. Measurements were performed using two antenna polarizations, (vertical and horizontal). The worst case emissions were recorded. All measurements may be performed using either the peak, average or quasi-peak detector functions. If the peak detector data exceeds or is marginally close to the limits, the measurements are repeated using a quasi-peak detector or average function as required by the specification for final determination of compliance. The QP and average detectors have a linear response.

The detected emission levels were maximized by rotating the EUT, adjusting the positions of all cables, and by scanning the measurement antenna from 1 to 4 meters above the ground.

11.1.1 Field Strength Calculation

The field strength is calculated by adding the Antenna Factor and Cable Loss, and by subtracting the Amplifier Gain from the measured reading. The basic equation is as follows:

$$FS = RA + AF + CF - AG + HPF + PKA$$

Where: FS = Field Strength

RA = Receiver Amplitude

AF = Antenna Factor

CF = Cable Attenuation Factor



AG = Amplifier Gain

HPF = High pass Filter Loss

PKA = Peak to Average Factor (This is only used for average measurements above 1 GHz)

The Peak to average factor is used when average measurements are required. It is calculated by the highest duty cycle in percent over any 100mS transmission. The factor in dB is 20*Log(1/100 mS) = -40 dB.

11.1.2 Duty Cycle

The Peak to average factor is calculated by the highest duty cycle in percent over any 100mS transmission. The factor in dB is 20 * Log(Duty cycle/100). The transmitter operates for a maximum duration of 1 ms in any 100 ms interval for a 10% maximum duty cycle. 20 Log*(1 mSec/100mSec) = -40 dB Peak to average Correction factor.

Since the difference between the peak and the average limits are 20 dB, there is no need to use a correction factor of more than 20 dB. Therefore, a 20 dB factor was used.

11.1.3 Radiated Emissions Test Results

Test Date	January 19 to 21, 2022
Test Distance	3 Meters
Specification	FCC Part 15 Subpart C & RSS-210 Section B.10
Notes	Serial # RMC8
Abbreviations	Pol = Antenna Polarization; V = Vertical; H = Horizontal; P = peak; Q = QP
Configuration	The EUT is in the transmit mode with the receiver on

This table includes all emissions except Fundamental, Band edge and harmonics emissions.

Freq. MHz	Meter Reading dBuV	Dec.	Ant. Pol.	Ant Factor dB/m	Cbl/amp Factors	Dist Fact dB	EUT dBuV/m	Limit dBuV/m	Margin Under Limit dB	Note
34.4	9.5	P	H	12.6	0.6	0.0	22.7	40.0	17.3	
44.9	8.8	P	H	10.3	0.7	0.0	19.8	40.0	20.2	
52.7	7.9	P	H	9.5	0.8	0.0	18.2	40.0	21.8	
59.8	11.5	P	H	9.2	0.8	0.0	21.5	40.0	18.5	
69.8	7.4	P	H	9.3	0.9	0.0	17.6	40.0	22.4	
79.2	11.9	P	H	9.4	0.9	0.0	22.2	40.0	17.8	
95.2	16.8	P	H	10.0	1.0	0.0	27.8	43.5	15.7	
111.2	14.0	P	H	11.0	1.1	0.0	26.1	43.5	17.4	
121.2	11.6	P	H	11.7	1.2	0.0	24.5	43.5	19.0	
131.7	9.1	P	H	12.2	1.2	0.0	22.5	43.5	21.0	
149.9	10.3	P	H	12.8	1.3	0.0	24.4	43.5	19.1	
163.2	9.1	P	H	13.1	1.4	0.0	23.6	43.5	19.9	
174.8	13.0	P	H	13.4	1.4	0.0	27.8	43.5	15.7	
181.4	11.5	P	H	13.6	1.5	0.0	26.6	43.5	16.9	
200.7	11.3	P	H	14.4	1.5	0.0	27.2	43.5	16.3	
226.7	9.3	P	H	14.9	1.6	0.0	25.8	46.0	20.2	
264.0	13.5	P	H	12.2	1.8	0.0	27.5	46.0	18.5	
288.6	9.6	P	H	13.5	1.8	0.0	24.9	46.0	21.1	
316.9	14.1	P	H	14.5	1.9	0.0	30.5	46.0	15.5	
349.0	8.9	P	H	14.3	2.0	0.0	25.2	46.0	20.8	
398.8	9.1	P	H	15.4	2.2	0.0	26.7	46.0	19.3	
452.4	9.7	P	H	16.6	2.3	0.0	28.6	46.0	17.4	
476.3	9.5	P	H	17.1	2.4	0.0	29.0	46.0	17.0	



Freq. MHz	Meter Reading dBuV	Decet.	Ant. Pol.	Ant Factor dB/m	Cbl/amp Factors	Dist Fact dB	EUT dBuV/m	Limit dBuV/m	Margin Under Limit dB	Note
573.8	9.2	P	H	18.4	2.7	0.0	30.3	46.0	15.7	
656.3	9.0	P	H	20.1	2.8	0.0	31.9	46.0	14.1	
747.5	8.7	P	H	20.9	3.0	0.0	32.6	46.0	13.4	
815.0	9.0	P	H	21.5	3.2	0.0	33.7	46.0	12.3	
897.5	9.1	P	H	22.7	3.3	0.0	35.1	46.0	10.9	
957.5	8.6	P	H	23.4	3.5	0.0	35.5	46.0	10.5	
1137.5	42.2	P	H	24.6	-34.1	0.0	32.7	74.0	41.3	1
1317.5	43.0	P	H	25.1	-34.1	0.0	34.0	74.0	40.0	1
1510.0	43.0	P	H	25.0	-34.1	0.0	33.9	74.0	40.1	1
1770.0	44.0	P	H	26.6	-34.0	0.0	36.6	74.0	37.4	1
1947.5	43.5	P	H	27.6	-33.9	0.0	37.2	74.0	36.8	1
2132.5	42.3	P	H	27.6	-33.7	0.0	36.2	74.0	37.8	1
2297.5	41.5	P	H	27.7	-33.7	0.0	35.5	74.0	38.5	1
2522.5	42.0	P	H	28.5	-33.3	0.0	37.2	74.0	36.8	1
2780.0	42.6	P	H	28.8	-33.2	0.0	38.2	74.0	35.8	1
2932.5	43.2	P	H	29.6	-32.9	0.0	39.9	74.0	34.1	1
3077.5	41.9	P	H	30.6	-32.8	0.0	39.7	74.0	34.3	1
3265.0	41.0	P	H	31.1	-32.4	0.0	39.7	74.0	34.3	1
3812.5	40.8	P	H	32.8	-32.2	0.0	41.4	74.0	32.6	1
4082.5	41.8	P	H	32.4	-31.8	0.0	42.4	74.0	31.6	1
4260.0	41.3	P	H	32.4	-31.6	0.0	42.1	74.0	31.9	1
4510.0	40.6	P	H	32.9	-31.4	0.0	42.1	74.0	31.9	1
4747.5	41.6	P	H	33.2	-31.0	0.0	43.8	74.0	30.2	1
4940.0	41.6	P	H	33.3	-30.6	0.0	44.3	74.0	29.7	1
5295.0	40.3	P	H	33.7	-30.0	0.0	44.0	74.0	30.0	1
5702.5	41.3	P	H	33.9	-29.9	0.0	45.3	74.0	28.7	1
5905.0	41.1	P	H	34.0	-29.6	0.0	45.5	74.0	28.5	1
6527.5	40.3	P	H	34.4	-29.2	0.0	45.5	74.0	28.5	1
6897.5	42.2	P	H	35.3	-29.0	0.0	48.5	74.0	25.5	1
7330.0	42.5	P	H	36.4	-29.0	0.0	49.9	74.0	24.1	1
7500.0	42.3	P	H	36.5	-28.9	0.0	49.9	74.0	24.1	1
7747.5	41.4	P	H	36.3	-28.5	0.0	49.2	74.0	24.8	1
7922.5	41.3	P	H	36.7	-28.8	0.0	49.2	74.0	24.8	1
8150.0	40.9	P	H	37.0	-28.2	0.0	49.7	74.0	24.3	1
8702.5	41.2	P	H	37.6	-28.6	0.0	50.2	74.0	23.8	1
8920.0	42.3	P	H	37.9	-28.8	0.0	51.4	74.0	22.6	1
9172.5	40.9	P	H	37.8	-28.6	0.0	50.1	74.0	23.9	1
9375.0	40.7	P	H	37.9	-28.6	0.0	50.0	74.0	24.0	1
9902.5	40.2	P	H	38.1	-29.2	0.0	49.1	74.0	24.9	1
33.3	12.1	P	V	12.9	0.6	0.0	25.6	40.0	14.4	
39.9	11.5	P	V	11.2	0.7	0.0	23.4	40.0	16.6	
44.4	8.1	P	V	10.4	0.7	0.0	19.2	40.0	20.8	
53.8	10.4	P	V	9.5	0.8	0.0	20.7	40.0	19.3	
59.8	10.0	P	V	9.2	0.8	0.0	20.0	40.0	20.0	
65.4	9.7	P	V	9.3	0.8	0.0	19.8	40.0	20.2	
78.1	19.0	P	V	9.3	0.9	0.0	29.2	40.0	10.8	
92.4	16.9	P	V	9.9	1.0	0.0	27.8	43.5	15.7	
102.4	17.1	P	V	10.5	1.1	0.0	28.7	43.5	14.8	
111.8	13.3	P	V	11.1	1.1	0.0	25.5	43.5	18.0	
122.3	11.4	P	V	11.8	1.2	0.0	24.4	43.5	19.1	
141.6	9.2	P	V	12.6	1.3	0.0	23.1	43.5	20.4	
165.4	8.9	P	V	13.1	1.4	0.0	23.4	43.5	20.1	
185.3	14.6	P	V	13.8	1.5	0.0	29.9	43.5	13.6	
197.4	8.5	P	V	14.3	1.5	0.0	24.3	43.5	19.2	



Freq. MHz	Meter Reading dBuV	Dect.	Ant. Pol.	Ant Factor dB/m	Cbl/amp Factors	Dist Fact dB	EUT dBuV/m	Limit dBuV/m	Margin Under Limit dB	Note
214.5	9.5	P	V	14.8	1.6	0.0	25.9	43.5	17.6	
228.3	15.4	P	V	15.0	1.6	0.0	32.0	46.0	14.0	
242.2	12.2	P	V	15.2	1.7	0.0	29.1	46.0	16.9	
289.2	9.3	P	V	13.5	1.8	0.0	24.6	46.0	21.4	
322.0	11.6	P	V	14.1	2.0	0.0	27.7	46.0	18.3	
372.4	8.8	P	V	14.5	2.1	0.0	25.4	46.0	20.6	
408.3	9.4	P	V	15.5	2.2	0.0	27.1	46.0	18.9	
460.5	10.1	P	V	16.8	2.4	0.0	29.3	46.0	16.7	
572.5	8.4	P	V	18.4	2.6	0.0	29.4	46.0	16.6	
646.3	9.1	P	V	19.6	2.8	0.0	31.5	46.0	14.5	
751.3	8.3	P	V	20.9	3.0	0.0	32.2	46.0	13.8	
843.8	8.3	P	V	22.1	3.2	0.0	33.6	46.0	12.4	
932.5	8.4	P	V	23.0	3.4	0.0	34.8	46.0	11.2	
1110.0	43.3	P	V	24.6	-34.0	0.0	33.9	74.0	40.1	1
1300.0	43.7	P	V	25.1	-34.1	0.0	34.7	74.0	39.3	1
1520.0	44.2	P	V	25.0	-34.1	0.0	35.1	74.0	38.9	1
1715.0	44.9	P	V	26.3	-34.1	0.0	37.1	74.0	36.9	1
1920.0	45.2	P	V	27.6	-33.8	0.0	39.0	74.0	35.0	1
2142.5	42.5	P	V	27.7	-33.7	0.0	36.5	74.0	37.5	1
2317.5	42.1	P	V	27.9	-33.6	0.0	36.4	74.0	37.6	1
2522.5	42.7	P	V	28.5	-33.3	0.0	37.9	74.0	36.1	1
2770.0	42.7	P	V	28.8	-33.3	0.0	38.2	74.0	35.8	1
2955.0	43.5	P	V	29.8	-32.9	0.0	40.4	74.0	33.6	1
3435.0	41.3	P	V	31.1	-32.3	0.0	40.1	74.0	33.9	1
3527.5	40.8	P	V	31.2	-32.4	0.0	39.6	74.0	34.4	1
3770.0	41.0	P	V	32.6	-32.2	0.0	41.4	74.0	32.6	1
3945.0	40.7	P	V	32.8	-31.8	0.0	41.7	74.0	32.3	1
4250.0	40.6	P	V	32.4	-31.7	0.0	41.3	74.0	32.7	1
5155.0	40.6	P	V	33.8	-30.1	0.0	44.3	74.0	29.7	1
5520.0	39.8	P	V	34.0	-29.6	0.0	44.2	74.0	29.8	1
5955.0	40.6	P	V	34.2	-29.5	0.0	45.3	74.0	28.7	1
6735.0	41.5	P	V	35.2	-29.0	0.0	47.7	74.0	26.3	1
7140.0	42.0	P	V	35.6	-29.1	0.0	48.5	74.0	25.5	1
8190.0	41.2	P	V	37.0	-28.1	0.0	50.1	74.0	23.9	1
8740.0	41.7	P	V	37.7	-28.5	0.0	50.9	74.0	23.1	1
8952.5	42.3	P	V	37.9	-28.9	0.0	51.3	74.0	22.7	1
9575.0	40.6	P	V	37.9	-28.9	0.0	49.6	74.0	24.4	1
9880.0	39.8	P	V	38.1	-29.2	0.0	48.7	74.0	25.3	1

Note 1: All Peak readings above 1 GHz were under the Average limits, so average readings are not required.

Judgment: Passed by at least 10 dB



Fundamental and Harmonic Emissions FCC 15.249; Three axis

	Tx	Spectrum Analyzer Readings dBuV									EUT	Peak	Ave	Peak	Ave	Margin
hrm	Freq	Peak			Ave	Peak			Ave	Corr.	Emission	Tot. FS	Limit		Under	
#	MHz	Vertical Polarization				Horizontal Polarization				Fact dB/m	Freq MHz	dBuV/m		dBuV/m		Limit dB
		X	Y	Z	Max	X	Y	Z	Max							
1	2402	59.1	65.1	67.3	47.3	67.8	63.9	58.4	47.8	34.1	2402.0	101.9	81.9	114	94	12.1
BE	2402	13.8	19.8	22.0	2.0	22.5	18.6	13.1	2.5	34.1	2390.0	56.6	36.6	74	54	17.4
2	2402	43.6	36.8	36.4	23.6	37.6	38.1	41.5	21.5	11.9	4804.0	55.5	35.5	74	54	18.5
3	2402	41.9	36.8	40.0	21.9	36.8	41.0	40.7	21.0	15.2	7206.0	57.1	37.1	74	54	16.9
4	2402	35.1	38.6	34.9	18.6	33.9	35.8	39.5	19.5	15.8	9608.0	55.3	35.3	74	54	18.7
1	2440	63.8	65.9	66.0	46.0	68.2	63.7	60.4	48.2	34.0	2440.0	102.2	82.2	114	94	11.8
2	2440	41.6	35.5	35.5	21.6	34.0	34.5	42.0	22.0	11.9	4880.0	53.9	33.9	74	54	20.1
3	2440	37.7	37.6	39.8	19.8	37.5	38.7	42.0	22.0	15.4	7320.0	57.4	37.4	74	54	16.6
4	2440	37.8	38.9	39.0	19.0	37.5	39.4	40.0	20.0	15.8	9760.0	55.8	35.8	74	54	18.2
1	2480	57.6	66.0	62.6	46.0	68.2	59.6	60.2	48.2	34.2	2480.0	102.4	82.4	114	94	11.6
BE	2480	10.3	18.7	15.3	-1.3	20.9	12.3	12.9	0.9	34.2	2483.5	55.1	35.1	74	54	18.9
2	2480	43.6	36.8	36.8	23.6	34.6	35.9	42.6	22.6	12.0	4960.0	55.6	35.6	74	54	18.4
3	2480	37.9	37.6	40.2	20.2	37.7	37.4	41.5	21.5	16.1	7440.0	57.6	37.6	74	54	16.4
4	2480	35.4	35.6	40.0	20.0	33.9	35.5	40.7	20.7	16.2	9920.0	56.9	36.9	74	54	17.1
Column numbers (see below for explanations)																
1	2	3	4	5	6	7	8	9	10	11	12	13	14	15	16	17

- Column #1. hrm = Harmonic; BE = Band Edge emissions
- Column #2. Frequency of Transmitter.
- Column #3. Uncorrected readings from the spectrum analyzer with First Axis Rotation.
- Column #4. Uncorrected readings from the spectrum analyzer with Second Axis Rotation.
- Column #5. Uncorrected readings from the spectrum analyzer with Third Axis Rotation.
- Column #6. Average Reading based on peak reading reduced by the Duty cycle correction
- Column #7. Uncorrected readings from the spectrum analyzer with First Axis Rotation.
- Column #8. Uncorrected readings from the spectrum analyzer with Second Axis Rotation.
- Column #9. Uncorrected readings from the spectrum analyzer with Third Axis Rotation.
- Column #10. Average Reading based on peak reading reduced by the Duty cycle correction
- Column #11. Corr. Factors = Cable Loss – Preamp Gain + Antenna Factor
- Column #12. Frequency of Tested Emission
- Column #13. Highest peak field strength at listed frequency.
- Column #14. Highest Average field strength at listed frequency.
- Column #15. Peak Limit.
- Column #16. Average Limit.
- Column #17. The margin (last column) is the worst-case margin under the peak or average limits for that row.

Overall Judgment: Passed by at least 11.6 dB

No other Emissions were detected from 30 to 25,000 MHz within 10 dB of the limits.



Figure 1. Drawings of Radiated Emissions Setup

Chamber E, anechoic

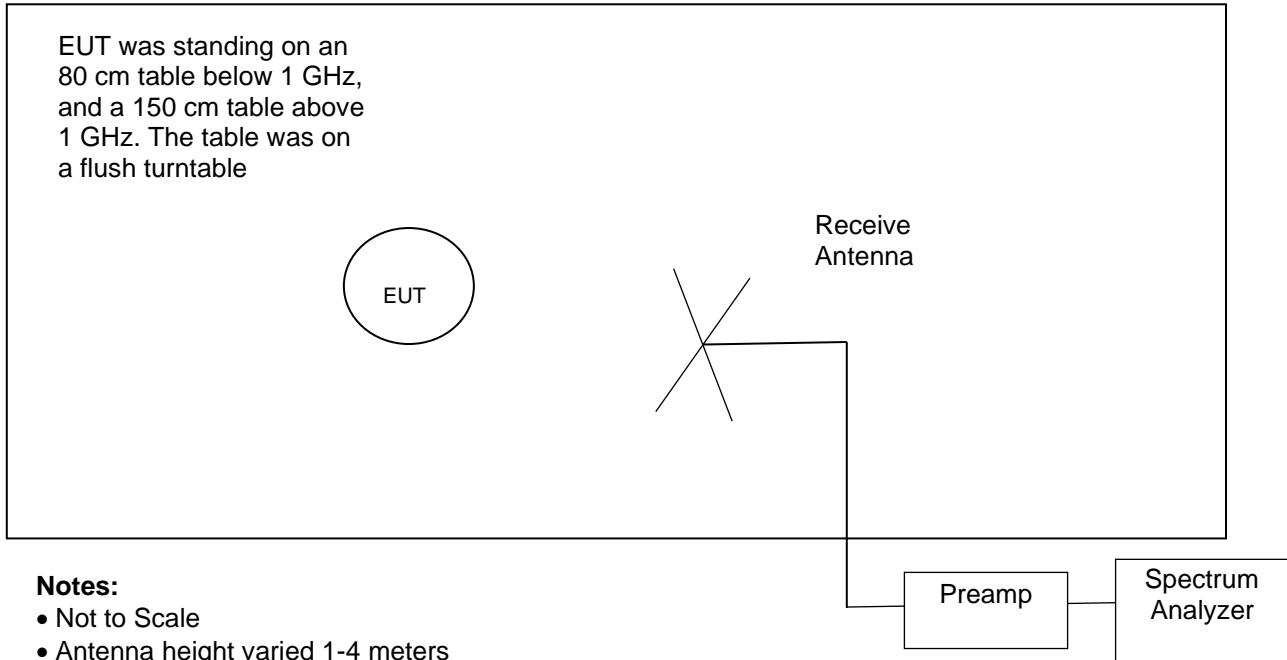

Notes:

- Not to Scale
- Antenna height varied 1-4 meters
- Distance from antenna to tested system is 3 meters
- AC cords not shown. They are connected to AC outlet with low-pass filter on turntable

Frequency Range	Receive Antenna	Pre-Amplifier	Spectrum Analyzer	High Pass Filter
30 to 200 MHz	ANT-80	Internal	REC-44	None*
200 to 1000 MHz	ANT-06	Internal	REC-44	None*
1 to 10 GHz	ANT-66	AMP-05	REC-44	HPF-06
10 to 18 GHz	ANT-66	AMP-20	REC-44	None*
18 to 25 GHz	ANT-48	AMP-59	REC-44	None*

* A high pass filter was not needed, since the fundamental frequency was outside of the amplifiers' pass band.



Radiated Emissions Test Setup for Frequencies from 30MHz to 1000MHz (Side View)

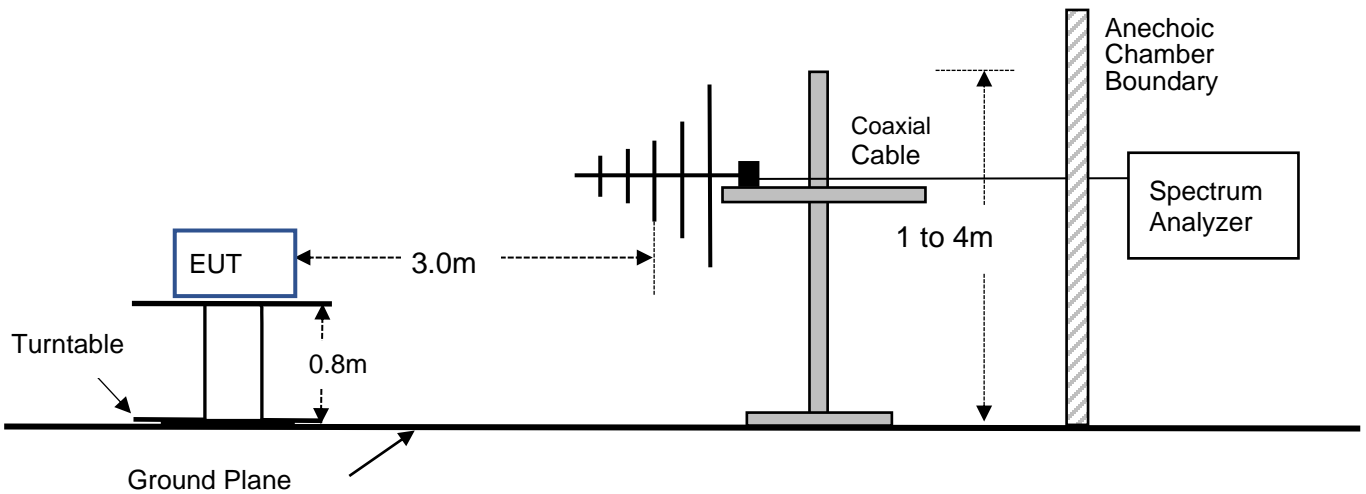

Radiated Emissions Test Setup for Frequencies over 1000MHz (Side View)

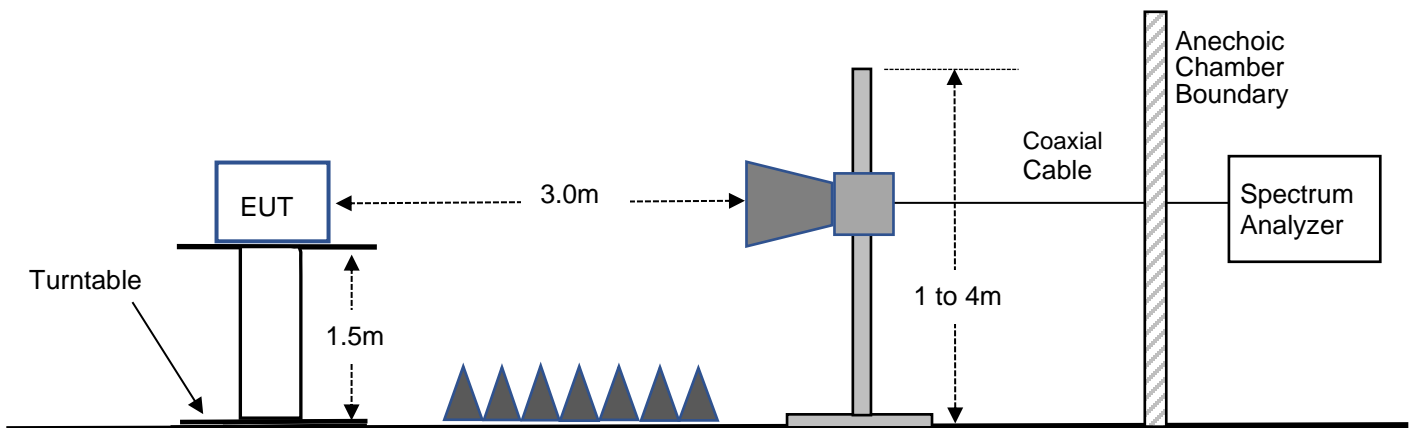

11.2 Occupied Bandwidth Data

The occupied bandwidth of the RF output was measured using a spectrum analyzer. The bandwidth was measured using the peak detector function. The spectrum analyzer was set to the MAX HOLD mode to record the worst case of the modulation. The marker-to-peak function was set to the peak of the emission. Then the marker-delta function was used to measure 20 dB down one side of the emission. The marker-delta function was reset and then moved to the other side of the emission, until it is (as close as possible to) even with the reference marker level. The marker-delta reading at this point is the bandwidth of the emission. The plots of the occupied bandwidth for the EUT are supplied on the following pages.

The 20 dB OBW is within the allowed 2400 to 2483.5 MHz authorized band.



Channel	99% EBW kHz	20 dB OBW kHz
2402	1023	1137
2440	1019	1117
2480	1022	1129

Serial # RMC8

Figure 2. Occupied Bandwidth Plots

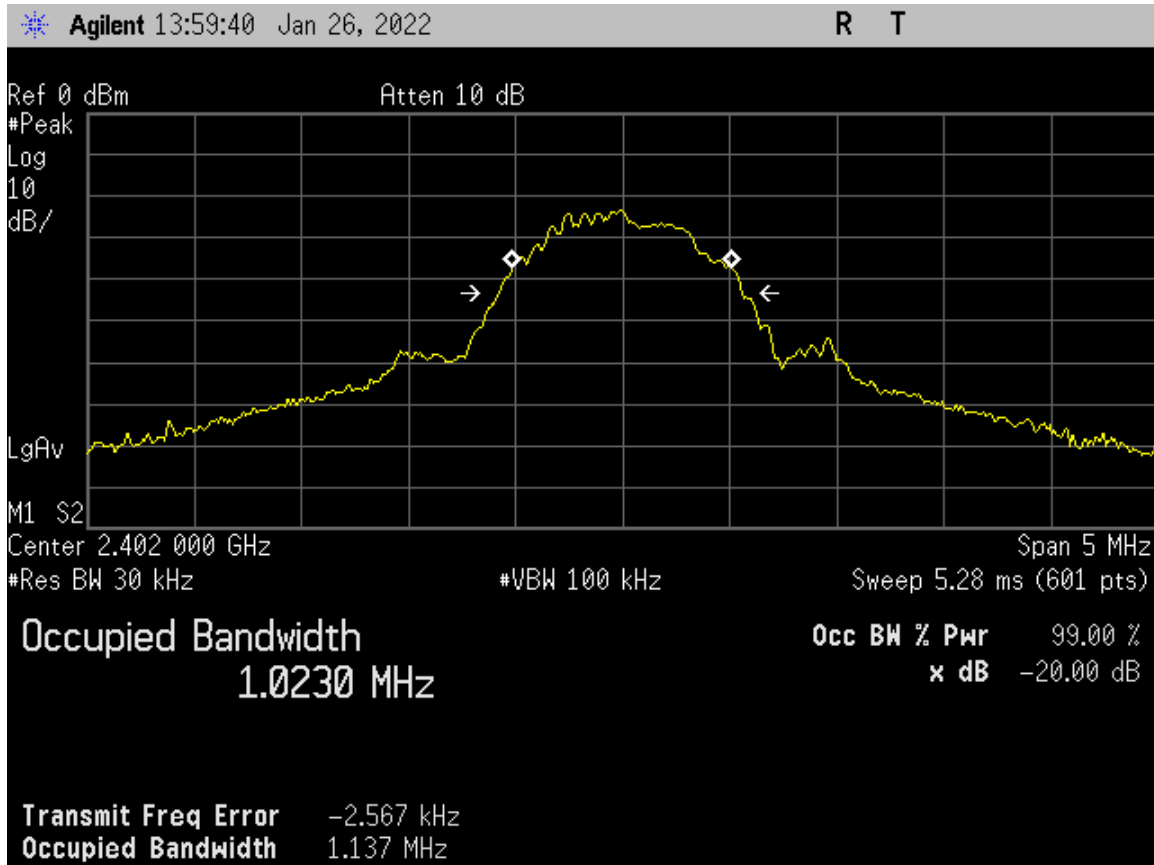

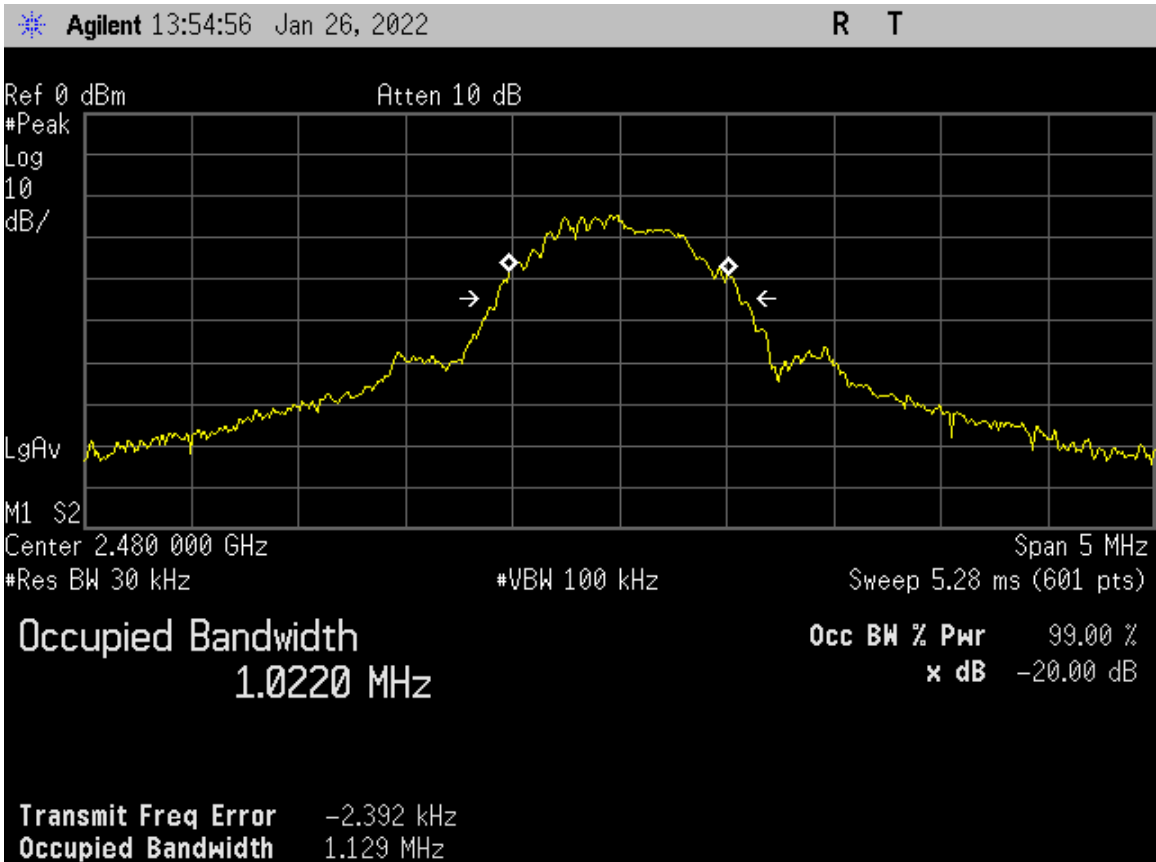
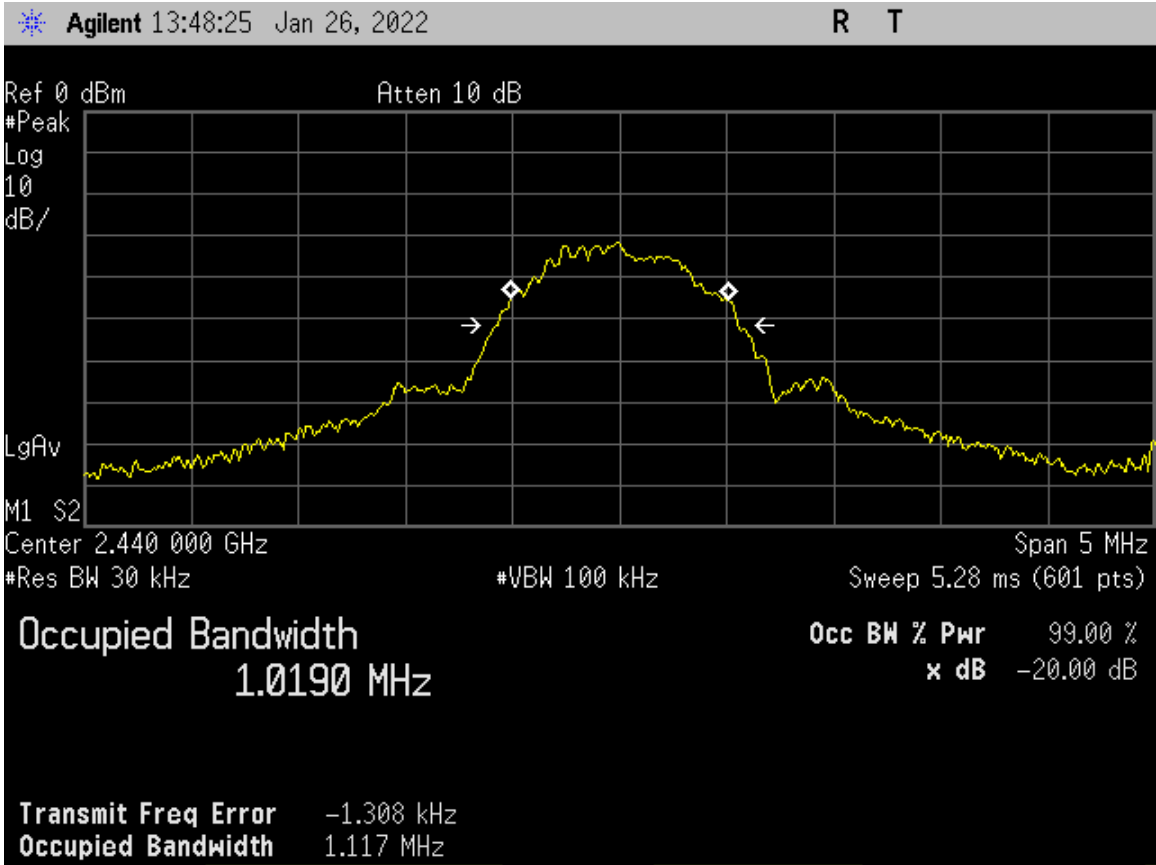



11.3 Unintentional Emissions (Receive Mode)

This section is only needed for 900 MHz receivers

Manufacturer	Aclara Technologies	Specification	FCC Part 15.209 & RSS-GEN
Model	PSC7231PSA	Test Date	02/04/2022
Serial Number	RMC7	Test Distance	3 Meters
Abbreviations	Pol = Antenna Polarization; V = Vertical; H = Horizontal; P = peak; Q = QP		
Notes	Corr. Factors = Cable Loss – Preamp Gain		
Configuration	Receive mode		

Freq. MHz	Meter Reading dBuV	Decet.	Ant. Pol.	Ant Factor dB/m	Cbl/amp Factors dB	Dist Fact dB	EUT dBuV/m	Limit dBuV/m	Margin Under Limit dB	Note
40.5	9.5	P	H	11.1	0.7	0.0	21.3	40.0	18.7	
50.4	7.0	P	H	9.7	0.7	0.0	17.4	40.0	22.6	
59.3	10.9	P	H	9.3	0.8	0.0	21.0	40.0	19.0	
78.6	12.2	P	H	9.4	0.9	0.0	22.5	40.0	17.5	
90.2	12.2	P	H	9.8	1.0	0.0	23.0	43.5	20.5	
95.2	16.2	P	H	10.0	1.0	0.0	27.2	43.5	16.3	
110.1	11.2	P	H	11.0	1.1	0.0	23.3	43.5	20.2	
121.7	12.2	P	H	11.7	1.2	0.0	25.1	43.5	18.4	
137.7	8.4	P	H	12.4	1.3	0.0	22.1	43.5	21.4	
152.1	8.8	P	H	12.8	1.3	0.0	22.9	43.5	20.6	
164.3	8.5	P	H	13.1	1.4	0.0	23.0	43.5	20.5	
175.9	19.4	P	H	13.5	1.4	0.0	34.3	43.5	9.2	
198.0	8.7	P	H	14.3	1.5	0.0	24.5	43.5	19.0	
220.1	9.4	P	H	14.9	1.6	0.0	25.9	46.0	20.1	
242.2	15.2	P	H	15.2	1.7	0.0	32.1	46.0	13.9	
289.2	8.3	P	H	13.5	1.8	0.0	23.6	46.0	22.4	
334.5	17.2	P	H	14.2	2.0	0.0	33.4	46.0	12.6	
376.1	8.8	P	H	14.6	2.1	0.0	25.5	46.0	20.5	
420.9	9.4	P	H	15.6	2.2	0.0	27.2	46.0	18.8	
464.3	9.5	P	H	17.0	2.4	0.0	28.9	46.0	17.1	
571.3	7.4	P	H	18.3	2.6	0.0	28.3	46.0	17.7	
657.5	8.5	P	H	20.2	2.9	0.0	31.6	46.0	14.4	
743.8	7.8	P	H	20.9	3.0	0.0	31.7	46.0	14.3	
840.0	8.1	P	H	22.0	3.2	0.0	33.3	46.0	12.7	
917.5	8.3	P	H	22.9	3.4	0.0	34.6	46.0	11.4	
1253.3	38.1	P	H	25.2	-31.4	0.0	31.9	74.0	42.1	1
1876.7	35.7	P	H	27.4	-30.7	0.0	32.4	74.0	41.6	1
2116.7	36.4	P	H	27.6	-30.0	0.0	34.0	74.0	40.0	1
2573.3	37.3	P	H	28.7	-29.4	0.0	36.6	74.0	37.4	1
3186.7	37.8	P	H	31.0	-28.2	0.0	40.6	74.0	33.4	1
3475.0	35.8	P	H	31.1	-28.0	0.0	38.9	74.0	35.1	1
3895.0	35.6	P	H	32.9	-27.4	0.0	41.1	74.0	32.9	1
4131.7	34.4	P	H	32.4	-27.0	0.0	39.8	74.0	34.2	1
4985.0	33.9	P	H	33.4	-25.1	0.0	42.2	74.0	31.8	1
37.2	10.8	P	V	11.8	0.6	0.0	23.2	40.0	16.8	
48.8	8.5	P	V	9.8	0.7	0.0	19.0	40.0	21.0	
60.9	9.8	P	V	9.2	0.8	0.0	19.8	40.0	20.2	
67.0	9.4	P	V	9.3	0.8	0.0	19.5	40.0	20.5	
72.5	7.7	P	V	9.3	0.9	0.0	17.9	40.0	22.1	
78.1	12.7	P	V	9.3	0.9	0.0	22.9	40.0	17.1	
86.4	8.1	P	V	9.6	1.0	0.0	18.7	40.0	21.3	
92.4	17.4	P	V	9.9	1.0	0.0	28.3	43.5	15.2	



Freq. MHz	Meter Reading dBuV	Dect.	Ant. Pol.	Ant Factor dB/m	Cbl/amp Factors dB	Dist Fact dB	EUT dBuV/m	Limit dBuV/m	Margin Under Limit dB	Note
102.9	14.1	P	V	10.5	1.1	0.0	25.7	43.5	17.8	
107.3	13.7	P	V	10.8	1.1	0.0	25.6	43.5	17.9	
121.7	12.9	P	V	11.7	1.2	0.0	25.8	43.5	17.7	
144.4	11.5	P	V	12.6	1.3	0.0	25.4	43.5	18.1	
148.2	12.1	P	V	12.7	1.3	0.0	26.1	43.5	17.4	
162.6	7.9	P	V	13.0	1.4	0.0	22.3	43.5	21.2	
179.7	9.1	P	V	13.6	1.4	0.0	24.1	43.5	19.4	
195.8	10.2	P	V	14.2	1.5	0.0	25.9	43.5	17.6	
217.3	9.1	P	V	14.8	1.6	0.0	25.5	46.0	20.5	
243.3	13.1	P	V	15.3	1.7	0.0	30.1	46.0	15.9	
279.1	7.5	P	V	13.0	1.8	0.0	22.3	46.0	23.7	
314.4	7.9	P	V	14.7	1.9	0.0	24.5	46.0	21.5	
345.3	8.3	P	V	14.3	2.0	0.0	24.6	46.0	21.4	
378.6	12.1	P	V	14.7	2.1	0.0	28.9	46.0	17.1	
415.8	9.7	P	V	15.6	2.2	0.0	27.5	46.0	18.5	
471.9	10.4	P	V	17.0	2.4	0.0	29.8	46.0	16.2	
580.0	7.5	P	V	18.5	2.7	0.0	28.7	46.0	17.3	
645.0	8.9	P	V	19.6	2.8	0.0	31.3	46.0	14.7	
746.3	8.1	P	V	20.9	3.0	0.0	32.0	46.0	14.0	
830.0	9.6	P	V	21.7	3.2	0.0	34.5	46.0	11.5	
925.0	9.8	P	V	22.9	3.4	0.0	36.1	46.0	9.9	
1120.0	37.8	P	V	24.6	-31.3	0.0	31.1	74.0	42.9	1
1785.0	38.0	P	V	26.7	-30.7	0.0	34.0	74.0	40.0	1
2088.3	37.0	P	V	27.6	-30.4	0.0	34.2	74.0	39.8	1
2651.7	36.6	P	V	28.8	-29.4	0.0	36.0	74.0	38.0	1
2945.0	37.0	P	V	29.7	-28.7	0.0	38.0	74.0	36.0	1
3091.7	37.6	P	V	30.7	-28.5	0.0	39.8	74.0	34.2	1
3746.7	36.1	P	V	32.5	-27.5	0.0	41.1	74.0	32.9	1
4420.0	35.4	P	V	32.9	-26.3	0.0	42.0	74.0	32.0	1
4943.3	34.1	P	V	33.4	-25.1	0.0	42.4	74.0	31.6	1

Note: All Peak readings above 1 GHz were under the Average limits, so average readings are not required.

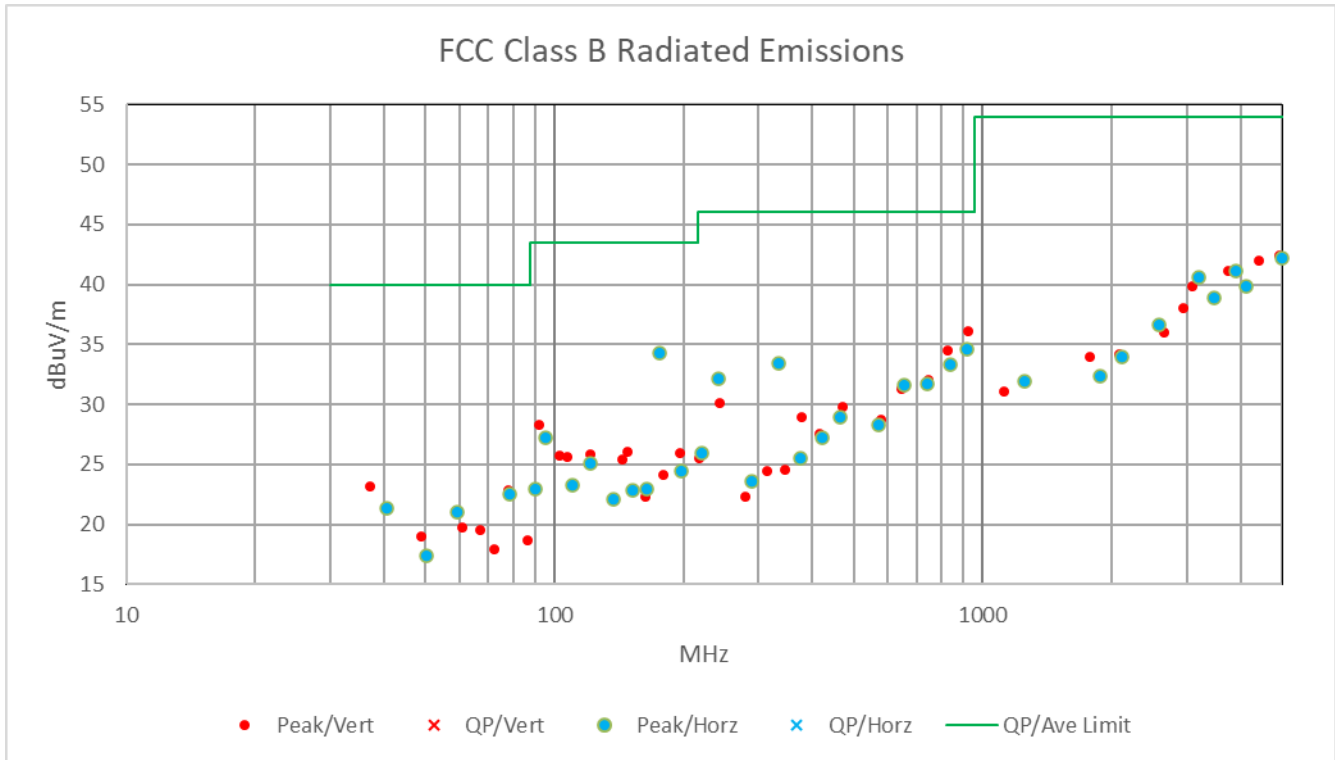

Radiated emissions in a graphical format. The above chart is the same data as the previous table. The peak limit is not shown, since the peak readings meet the lower average limit.

11.3.1 Measurement Instrumentation Uncertainty

Measurement	Uncertainty
Radiated Emissions, E-field, 3 meters, 30 to 200 MHz	4.7 dB
Radiated Emissions, E-field, 3 meters, 200 to 1000 MHz	6.2 dB
Radiated Emissions, E-field, 3 meters, 1 to 6 GHz	5.0 dB
Radiated Emissions, E-field, 3 meters, 6 to 18 GHz	5.5 dB
Radiated Emissions, E-field, 3 meters, 18 to 26 GHz	5.9 dB
Bandwidth using marker delta method at a span of 10 MHz	4 kHz
99% Occupied Bandwidth	1% of frequency span
Temperature THM-02	0.6 Deg C

The uncertainties represent expanded uncertainties expressed at approximately the 95% confidence level using a coverage factor of k=2 in accordance with CISPR 16-4-2.

12.0 REVISION HISTORY

Document RP-9571C Revisions:			
Rev.	Affected Sections	Description	Rationale