

Test Report No.8212307157

For Alvarion (formerly Flower & BreezeCom)

***Equipment Under Test:
BreezeAccess SU-M unit***

***From The Standards Institution
Of Israel
Industry Division
Telematics Laboratory
EMC Section***



Certificate No.1487-01

Test Report No.: 8212307157

Page 1 of 15 Pages

Title: Test on BreezeAccess SU-M unit

Order placed by:	Alvarion (formerly Flower & BreezeCom)
Address:	P.O.Box 13139. Tel Aviv 61131, Israel
Sample for test selected by:	The order
The date of test:	28/04/2002

Description of Equipment

Under Test (EUT):	BreezeAccess SU-M unit
Manufactured by:	Alvarion (formerly Flower & BreezeCom)

Reference Standard:

- ❖ CFR 47 FCC: "Rules and Regulations";
Part 15. "Radio frequency devices";
Subpart B: "Unintentional radiators" (1999).

Test Results: The EUT conforms to the requirements of CFR 47 FCC Part 15 Subpart B Sec.15.109 class B

This Test Report contains 15 pages and may be used only in full.	This Test Report applies only to the specimen tested and may not be applied to other specimens of the same product.
--	---

Table of Contents

1. Scope	3
2. EUT Description and operation	3
2.1 General description:	3
3. Test specification, Methods and Procedures	5
4. Measurements, examinations and derived results	5
4.1 Location of the Test Site:	5
4.2 Initial visual check and functional test:	5
4.3 Radiated emission test:	6
5. Compliance with specification	8
6. Appendix 1: Test equipment used	9
7. Appendix 2: Antenna Factor and Cable Loss	10
8. Appendix 3: Test configuration illustrations	12

1 Scope

This test report contains the results of the conducted and radiated emissions tests which were caused by the changes made in the EUT by the manufacturer.

2 EUT Description and operation

2.1 General description *:

Description of Equipment Under Test (EUT): BreezeAccess SU-M unit

Manufactured by: Alvarion (formerly Flower & BreezeCom)

The BreezeAccess SU-M-2.4 unit is a mechanical modification of the BreezeAccess 2.4GHz SU-R (LKT-SUR-24) unit. The modification is placing the SU-R card in a bigger mechanical enclosure enabling a DC-to-DC converter from 12V to 5V to be applied in the same box with the SU-R card. No electrical changes were done on the SU-R. The SU-M can be installed by a professional installer only.

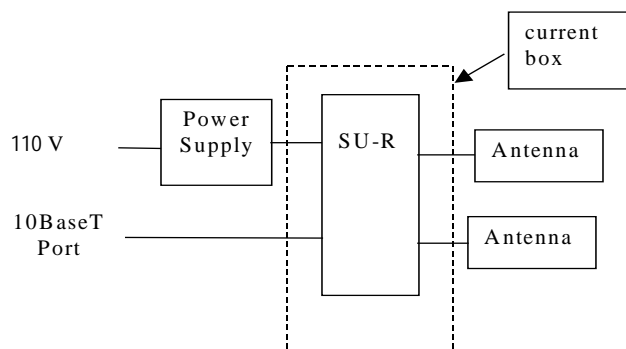

Figure 1: BreezeAccess 2.4GHz SU-R current grant configuration

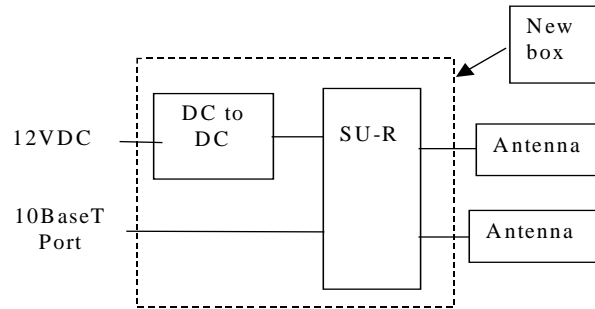

Figure 2: New setting of the BreezeAccess 2.4GHz for the SU-M unit

* All information is provided by the manufacturer.

3 Test specification, Methods and Procedures

Test Specification:

- ❖ CFR 47 FCC: "Rules and Regulations";
Part 15. "Radio frequency devices";
Subpart B: "Unintentional radiators" (1999).

Methods and Procedures:

- ❖ ANSI C63/4/1992: "American National Standard for Methods of Measurement of Radio-Noise Emissions from Low-Voltage Electrical and Electronic Equipment in the range of 9 kHz to 40 GHz".

4 Measurements, examinations and derived results

4.1 Location of the Test Site:

Radiated emission test was conducted in an Open Area Test Site located at Kibbutz Native Halamed Hai in Emek HaEla, Israel.

4.2 Initial visual check and functional test:

Initial visual check of the EUT was performed before testing. No external damages were found.

4.3 Radiated emission test:

The measurements were performed at the Open Area Test Site.

The EUT was arranged on a non-metallic table 0.8 m placed on the turn-table.

The photos of the test layout are presented in Appendix 3.

All measurements at the Open Area Test Site were performed at a 10 m measurement distance.

The Bilog 30 MHz-2 GHz antenna was used.

The Frequency range from 30 to 2000 MHz was investigated.

The measurements were performed at each frequency at which the signal was 10 dB below the limit or less.

The level were maximized by initially rotating turntable through 360°, varying the antenna height between 1 m and 4 m, rerouting EUT cables and changing antenna polarization from vertical to horizontal. The measuring equipment settings were:

Initial scan:

Detector type	Peak
Mode	Max hold
Bandwidth	120 kHz
Step size	Continuous sweep
Sweep time	>1 seconds/MHz

Measurements:

Detector type	Quasi-peak (CISPR 16)
Bandwidth	120 kHz
Measurement time	20 seconds/MHz
Observation	>15 seconds

4.3.1 Radiated emission test results:

Test results are presented in Table 1. All emissions are found below Class B limit.

**Table 1. Radiated emission test results
Specified std.: FCC Part 15 Class B**

Frequency (MHz)	Turn- table Angle (°)	Antenna Polariz.	Antenna Height (m)	Emission Level (dB μ V/m)	Limit @ 3m (dB μ V/m)	Margin (dB)	Results
60	89	V	2.63	33.6	40	6.4	Complies
69.5	359	V	2.78	28.3	40	11.7	Complies
111.5	227	V	1.61	31.8	43.5	11.7	Complies
185.8	296	V	1.25	27.9	43.5	15.6	Complies
275	0	H	2.67	33	46	13	Complies
279	269	H	3.23	41.7	46	4.3	Complies
284	276	H	3.04	38.6	46	7.4	Complies
290	258	H	3.05	33.9	46	12.1	Complies
295.7	249	H	3	36.1	46	9.9	Complies
300	244	H	3.27	33.9	46	12.1	Complies
303.4	242	H	2.76	29.8	46	16.2	Complies
310	244	H	2.74	31.9	46	14.1	Complies

Note 2: Emission level = E Reading (dB μ V) + Cable loss (dB) + Antenna Factor (dB/m) + Distance factor (10 dB).

For Cable Loss and Antenna Factor refer to Appendix 2.

Distance factor was added to extrapolate the measurements performed at 10 m distance to the specified limit at 3 m distance.

Test Report No.: 8212307157

Page 8 of 15 Pages

Title: Test on BreezeAccess SU-M unit

5 Compliance with specification

Test	Standard	Class	Test result
Radiated emission Frequencies range: 30-1000 MHz	FCC Part 15	Class B	Complies



Telematics Laboratory
06 May 2002



Name: Eng. Yuri Rozenberg
Position: Head of EMC Branch

Name: Albert Hertzenshtein
Position: Testing Engineer

6 Appendix 1: Test equipment used

All measurements equipment is on SII calibration schedule with a recalibration interval not exceeding once a year.

Instrument	Manufacturer	Model	Serial No.	Last calibration date	Next calibration date
EMI Receiver	HP	8546A+85460A	SII 4068	11/01	11/02
Antenna Bilog 30 – 2000 MHz	Schaffner- Chase	CBL6112B	S/N 2714 SII 5119	12/01	12/02
Antenna Mast	R&S	HCM	100002	N/A	N/A
Metallic turntable	R&S	HCT12	100001	N/A	N/A
Positioning controller	R&S	HCC	100002	N/A	N/A

7 Appendix 2: Antenna Factor and Cable Loss

Cable Loss (10m cable + Mast)

Point	Frequency (MHz)	Cable Loss (dB)	Point	Frequency (MHz)	Cable Loss (dB)
1	30	0.53	21	1000	3.68
2	50	0.75	22	1100	3.82
3	100	1.08	23	1200	4.07
4	150	1.39	24	1300	4.24
5	200	1.61	25	1400	4.43
6	250	1.752	26	1500	4.6
7	300	2.00	27	1600	4.7
8	350	2.15	28	1700	4.85
9	400	2.26	29	1800	4.98
10	450	2.383	30	1900	5.19
11	500	2.52	31	2000	5.34
12	550	2.606	32	2100	5.51
13	600	2.75	33	2200	5.69
14	650	2.856	34	2300	5.89
15	700	3.06	35	2400	6.07
16	750	3.201	36	2500	6.22
17	800	3.27	37	2600	6.28
18	850	3.38	38	2700	6.41
19	900	3.46	39	2800	6.53
20	950	3.55	40	2900	6.84

Antenna Factor
Antenna Bilog mfr Schaffner Chase EMC Ltd.
Model CBL6112B S/N 2714

Frequency (MHz)	Antenna Factor (dB/m)	Frequency (MHz)	Antenna Factor (dB/m)	Frequency (MHz)	Antenna Factor (dB/m)	Frequency (MHz)	Antenna Factor (dB/m)	Frequency (MHz)	Antenna Factor (dB/m)
30	18.00	125	11.35	350	14.30	750	20.00	1300	23.10
32	16.90	130	11.00	360	14.50	760	20.00	1320	23.10
34	15.80	135	10.65	370	14.70	770	20.00	1340	23.30
36	14.80	140	10.40	380	14.80	780	20.00	1360	23.40
38	13.70	145	10.15	390	15.15	790	19.90	1380	23.80
40	12.60	150	9.70	400	15.70	800	19.90	1400	24.10
42	11.60	155	9.35	410	16.40	810	19.95	1420	24.40
44	10.60	160	9.10	420	16.70	820	20.20	1440	24.50
46	9.60	165	8.90	430	16.40	830	20.35	1460	24.70
48	8.80	170	8.80	440	16.30	840	20.40	1480	24.70
50	7.90	175	8.75	450	16.35	850	20.40	1500	25.00
52	7.20	180	8.60	460	16.70	860	20.30	1520	25.10
54	6.60	185	8.50	470	17.00	870	20.30	1540	25.10
56	6.00	190	8.40	480	17.20	880	20.30	1560	25.20
58	5.60	185	8.50	490	17.35	890	20.30	1580	25.20
60	5.20	200	8.70	500	17.40	900	20.30	1600	25.20
62	5.00	205	8.95	510	17.45	910	20.35	1620	25.30
64	4.80	210	8.80	520	17.50	920	20.40	1640	25.50
66	4.80	215	8.55	530	17.95	930	20.40	1660	25.70
68	4.90	220	8.90	540	18.80	940	20.60	1680	25.90
70	5.00	225	9.30	550	19.05	950	20.60	1700	25.90
72	5.30	230	9.80	560	18.80	960	20.60	1720	26.00
74	5.60	235	10.40	570	18.70	970	20.60	1740	25.90
76	6.10	240	10.90	580	18.60	980	20.70	1760	25.90
78	6.40	245	11.25	590	18.60	990	20.80	1780	25.70
80	6.90	250	11.70	600	18.80	1000	20.90	1800	25.80
82	7.30	255	12.20	610	19.10	1020	21.30	1820	25.90
84	7.60	260	12.80	620	19.20	1040	21.50	1840	26.10
86	8.00	265	12.80	630	19.20	1060	21.70	1860	26.30
88	8.40	270	12.40	640	19.20	1080	21.90	1880	26.50
90	8.80	275	12.30	650	19.10	1100	21.90	1900	26.80
92	9.20	280	12.30	660	19.10	1120	22.00	1920	27.00
94	9.60	285	12.35	670	19.00	1140	22.20	1940	27.00
96	9.90	290	12.40	680	18.90	1160	22.30	1960	27.10
98	10.40	295	12.60	690	18.95	1180	22.40	1980	27.20
100	10.70	300	12.70	700	19.10	1200	22.50	2000	27.30
105	11.15	310	13.15	710	19.35	1220	22.70		
110	11.40	320	13.50	720	19.60	1240	22.90		
115	11.50	330	13.60	730	19.90	1260	23.00		
120	11.50	340	13.80	740	20.00	1280	12.80		

8 Appendix 3: Test configuration illustrations

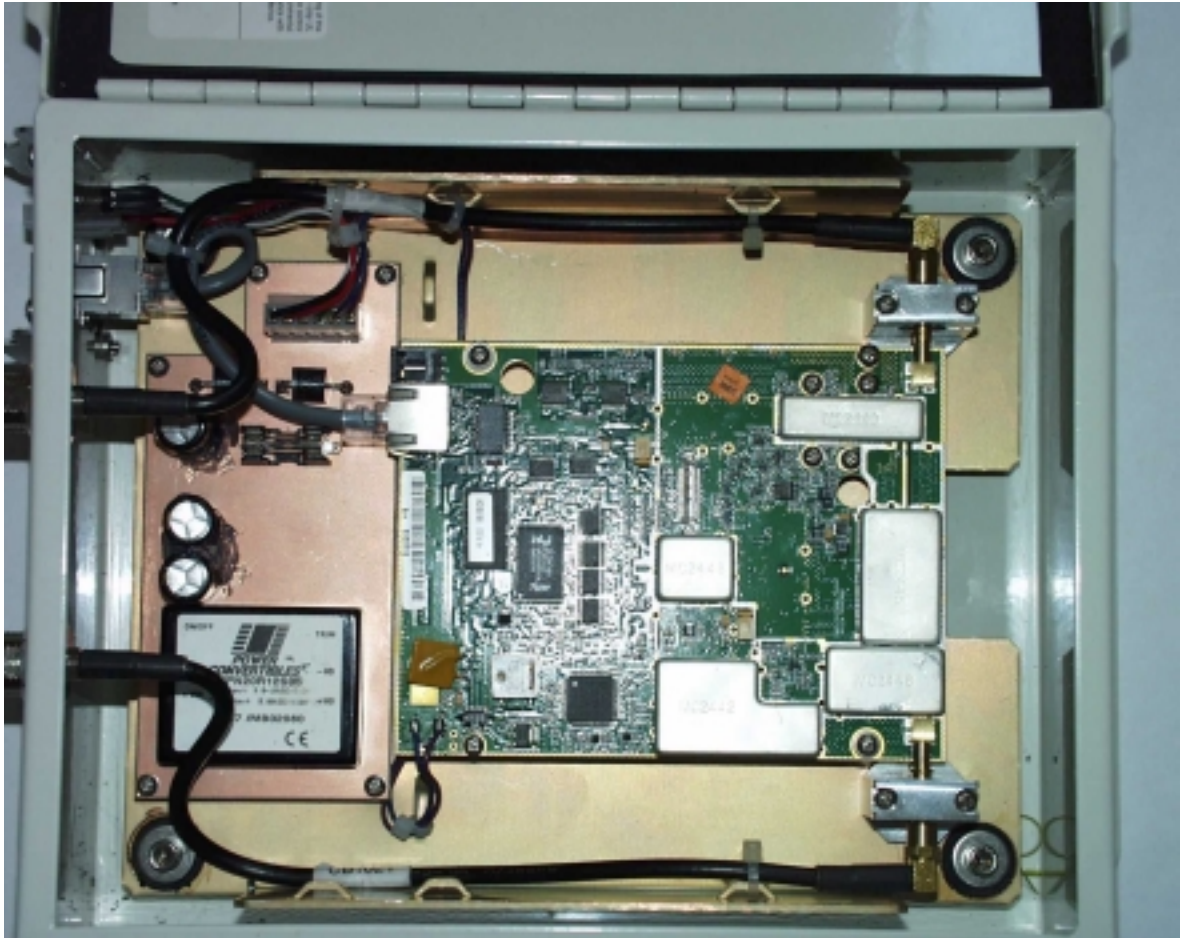

Photo 1.
BreezeAccess SU-M unit
Internal view



Photo 2.
BreezeAccess SU-M unit
Radiated emission test setup



Photo3.
BreezeAccess SU-M unit
Radiated emission test setup

Test Report No.: 8212307157

Page 15 of 15 Pages

Title: Test on BreezeAccess SU-M unit

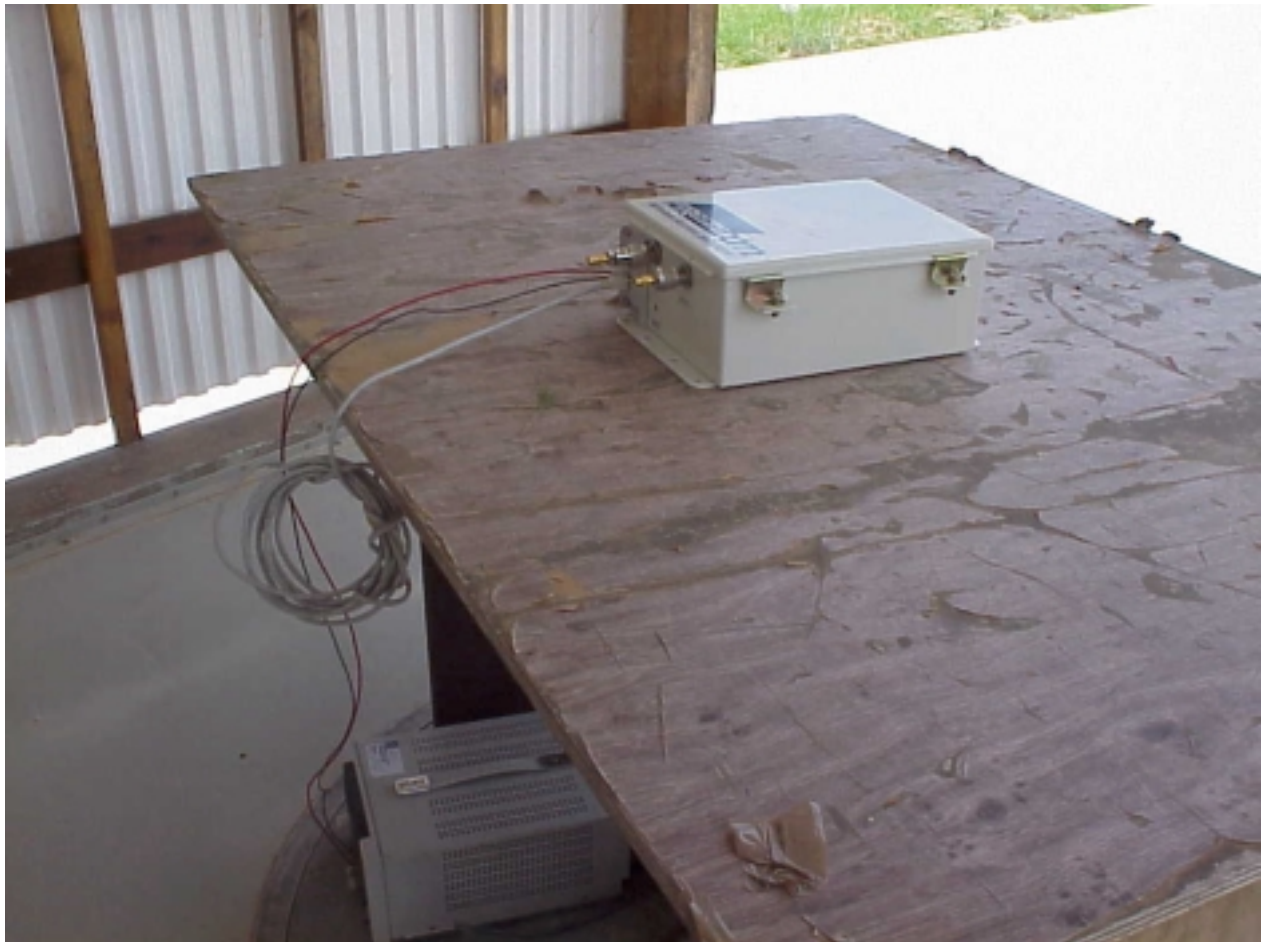

Photo 4.
BreezeAccess SU-M unit
Radiated emission test setup