



Test Report No. 9012332799/1

Applicant: Alvarion Ltd

Equipment Under Test (EUT):
BreezeMAX Broadband Wireless Access
BreezeMax Extreme CPE System 5.x

Model: XTRM-SU-OD-1D-4.9-2-A

**From The Standards Institution
Of Israel
Industry Division
Telematics Laboratory
EMC Section**



ACCLASS Accreditation Services

Certificate Number: AT-1359



Test report N: 9012332799/1

Page 1 of 49

Title: BreezeMax Extreme CPE System 5.x

Model: XTRM-SU-OD-1D-4.9-2-A

FCC ID: LKT-EXTR-CPE-50

Table of contents

1.	Applicant information	2
2.	Test performance	2
3.	Summary of test	3
4.	Equipment under test description.	4
4.1	General description	4
5.	Environmental evaluation and exposure limit according to FCC part 1, §1.1307, §1.1310	5
6.	EUT test configuration	5
7.	Test results	6
7.1	Transmitter characteristics	6
7.1.1	Peak transmit power test according to §90.1215(a).	6
7.1.2	Peak power spectral density test according to §90.1215(a).	11
7.1.3	Power spectral density mask according to §90.210(m).	12
7.1.4	Undesired conducted emissions test according to § 90.210 m	15
7.1.5	Undesired radiated emissions test according to § 90.210 (m).	23
7.1.6	Ratio of the peak excursion per part 90.1215(e)	37
7.1.7	Frequency stability according to § 90.213	41
8.	APPENDIX A	42
9.	APPENDIX B	44
10.	APPENDIX C	49



Test report N: 9012332799/1
Title: BreezeMax Extreme CPE System 5.x
Model: XTRM-SU-OD-1D-4.9-2-A

Page 2 of 49

FCC ID: LKT-EXTR-CPE-50

1. Applicant information

Applicant:	Alvarion Ltd
Address:	21A Habarzel str, Tel-Aviv, 69710, Israel
Sample for test selected by:	The customer
The date of tests:	9, 11 May, 15, 20-21 June 2010.

Equipment under test information

Description of Equipment Under Test (EUT):	BreezeMax Extreme CPE System 5.x
Model:	XTRM-SU-OD-1D-4.9-2-A
Serial Number:	NA
Manufactured by:	Alvarion Ltd

2. Test performance

Location:	SII EMC Section
Purpose of test:	Apparatus compliance verification in accordance with emission requirements
Test specifications:	47 CFR parts 90. 210 – 90. 215 part 1 §1.1310

Reference Documents:

CFR 47 FCC: Rules and Regulations; Part 15. "Radio frequency devices"; Part. 90. Private land mobile radio services.

Note: Test Report # 9012332799 has been superseded by the presented Test Report # 9012332799/1.

This Test Report contains 49 pages and may be used only in full.	This Test Report applies only to the specimen tested and may not be applied to other specimens of the same product.
--	---



Test report N: 9012332799/1
Title: BreezeMax Extreme CPE System 5.x
Model: XTRM-SU-OD-1D-4.9-2-A

Page 3 of 49

FCC ID: LKT-EXTR-CPE-50

3. Summary of test

The EUT was found to be in compliance with requirements of: 47CFR Part 90, §§ 90.210, 90.213 and 90.1215.

Transmitter characteristics	Subclasses
Peak transmitter power	90.1215(a)
Peak power spectral density	90.1215(a)
Power spectral density mask	90.210(m)
Undesired conducted emissions test	90.210 m
Undesired radiated emissions test	90.210 m
Ratio of the peak excursion test	90.1215(e)
Frequency stability test	90.213

**Electronics and
Telematics Laboratory**
16 July 2011

Test performed by:

Mr. Michael Feldman
Test technician

Test report approved by:

Mr. Yuri Rozenberg.
Head of EMC Branch

**Test report N:** 9012332799/1

Page 4 of 49

Title: BreezeMax Extreme CPE System 5.x**Model:** XTRM-SU-OD-1D-4.9-2-A**FCC ID:** LKT-EXTR-CPE-50

4. Equipment under test description.

*The customer provided description.

4.1 General description

BreezeMAX Extreme 5x is a high capacity, IP services oriented Broadband Wireless Access system. BreezeMAX Extreme 5x is digital modulated TDD system operating in the 4900MHz up to 5950MHz band. The system contains a Base station unit and a Subscriber unit.

Subscriber unit configuration:

The basic system configuration is a two-box configuration that contains

Indoor unit that contains a power supply and an Ethernet 10/100BaseT (RJ 45) interface.

Outdoor unit containing the entire radio and digital section . Radio Input/Output is connected to two N type connectors , TX/RX and RX allowing connection to dual port antenna .

A single CAT5 cable connecting the indoor and outdoor unit serves for carrying the data as well as for transferring power, management and control signals.

The subscriber indoor unit is a single power supply (55VDC) and Ethernet 10/100BaseT (RJ 45) interface.

EUT technical characteristics

Transmitter technical characteristics.		Note	
Stand-alone/fixed use			
Assigned frequency range	4940 MHz – 4990 MHz		
Operating frequency range	4942.5 MHz – 4987.5 MHz	5 MHz EBW	
	4945 MHz – 4985 MHz	10 MHz EBW	
RF channel spacing	5/10 MHz		
Antenna connection	Internal SMA connector.		
Type of modulation	QPSK, 4QAM, 16QAM, 64QAM		
Type of multiplexing	OFDM		
Modulating test signal (baseband)	PRBS		
Antenna information			
Type	Manufacturer	Model	Gain, dBi
Internal antenna, dual slant	Laird Technologies	AN1417-02	17

Test report N: 9012332799/1

Page 5 of 49

Title: BreezeMax Extreme CPE System 5.x

Model: XTRM-SU-OD-1D-4.9-2-A

FCC ID: LKT-EXTR-CPE-50

5. Environmental evaluation and exposure limit according to FCC part 1, §1.1307, §1.1310

Limit for power density for general population/uncontrolled exposure is 1(mW/cm²) or 10 (W/m²).

The power density calculation is $S = (Pt / 4\pi r^2)$.

Where:

Pt - The transmitted power (EIRP) (mW)

r - The distance from the unit. (cm)

The limit 1(mW/cm²) can be calculated from the above based on the following data:

Pt- the transmitted power which is equal to the peak output power 23.5 dBm plus external antenna gain 17 dBi. The maximum peak EIRP = 40.5 dBm = 11220 mW

Maximum allowed distance “r”, where RF exposure limits may not be exceeded,

$r = \text{SQRT} (11220/4\pi)$ and is more than 30 cm from the antenna main lobe.

6. EUT test configuration

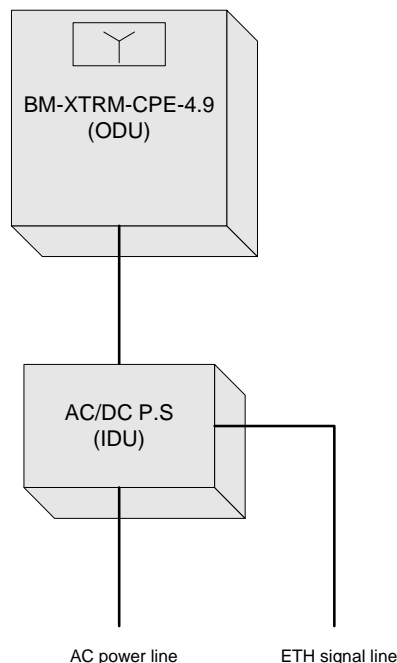

Fig. 1. EUT block diagram.



Test report N: 9012332799/1
Title: BreezeMax Extreme CPE System 5.x
Model: XTRM-SU-OD-1D-4.9-2-A

Page 6 of 49

FCC ID: LKT-EXTR-CPE-50

7. Test results

7.1 Transmitter characteristics

7.1.1 Peak transmit power test according to §90.1215(a).

Method of measurement FCC part 90.1215 (c).
 Operating Frequency Range 4942.5 – 4987.5 MHz
 Ambient Temperature 22° C Relative Humidity 50% Air Pressure 1010 hPa

EBW, MHz	Carrier frequency, MHz	99% emission bandwidth MHz	Measured peak power, dBm	Specified limit, dBm	Reference to plots #
5.0	4942.5	4.44	22.49	27.0	1, 4
	4962.5	4.45	23.39	27.0	2, 5
	4987.5	4.44	23.55	27.0	3, 6
10	4945	9.09	22.45	30.0	7, 10
	4962.5	9.09	23.32	30.0	8, 11
	4985	9.09	23.44	30.0	9, 12

LIMIT

The maximum conducted output power should not exceed:

Channel bandwidth, MHz	High power transmitter limit, dBm
5	27
10	30

TEST PROCEDURE

The measurements were performed in normal (transmitting) mode of operation for carrier (channel) frequency at bottom, middle and the top of the 4940 - 4990 MHz frequency band under maximum data transfer bit rate. The EUT RF output was connected to the Spectrum Analyzer through appropriate attenuator and accounted with cable loss in SA settings. The 99% EBW measurements were performed with RBW = at least 1% of EBW and VBW>RBW

TEST EQUIPMENT USED:

3	4	5	11			
---	---	---	----	--	--	--



Test report N: 9012332799/1
Title: BreezeMax Extreme CPE System 5.x
Model: XTRM-SU-OD-1D-4.9-2-A

FCC ID: LKT-EXTR-CPE-50

5 MHz EBW option, 99% bandwidth

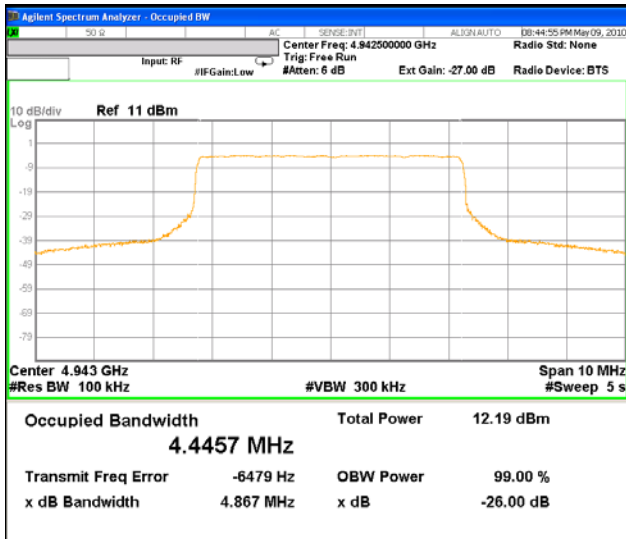

Plot # 1

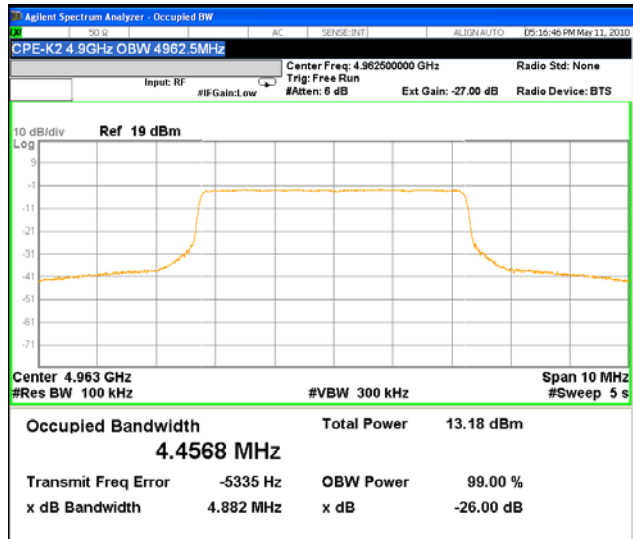

Plot # 2

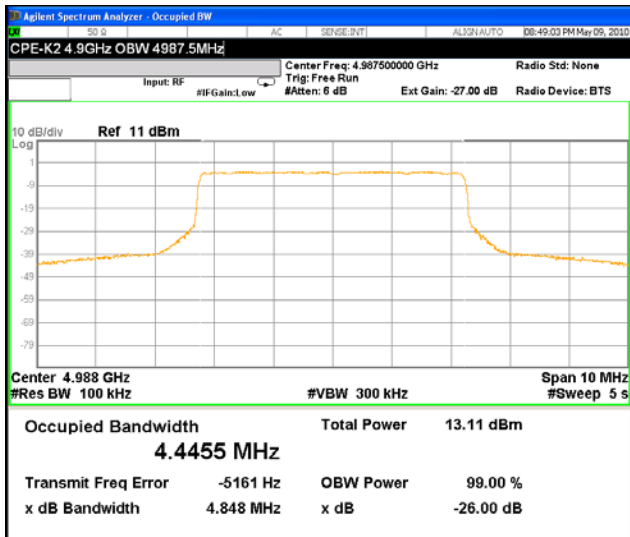

Plot # 3



Test report N: 9012332799/1
Title: BreezeMax Extreme CPE System 5.x
Model: XTRM-SU-OD-1D-4.9-2-A

Page 8 of 49

FCC ID: LKT-EXTR-CPE-50

5 MHz EBW option. Peak output power results

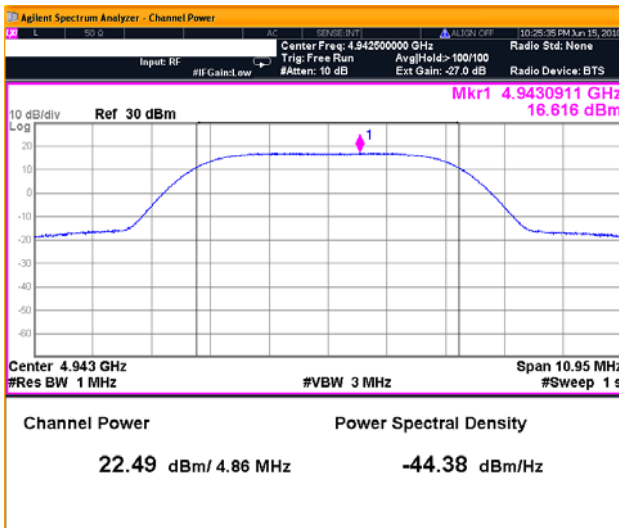

Plot # 4

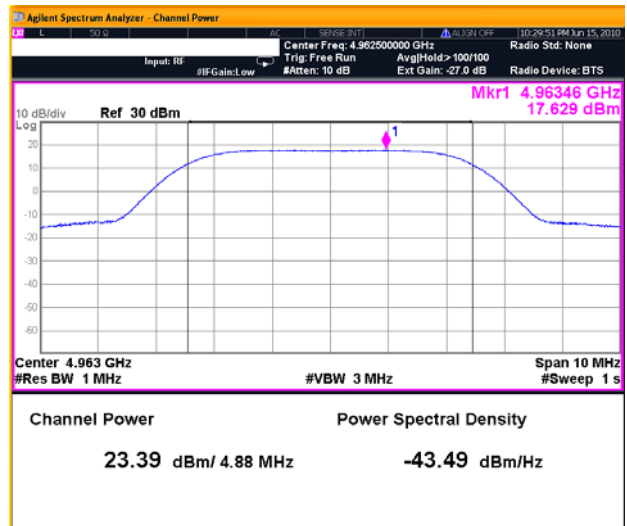

Plot # 5

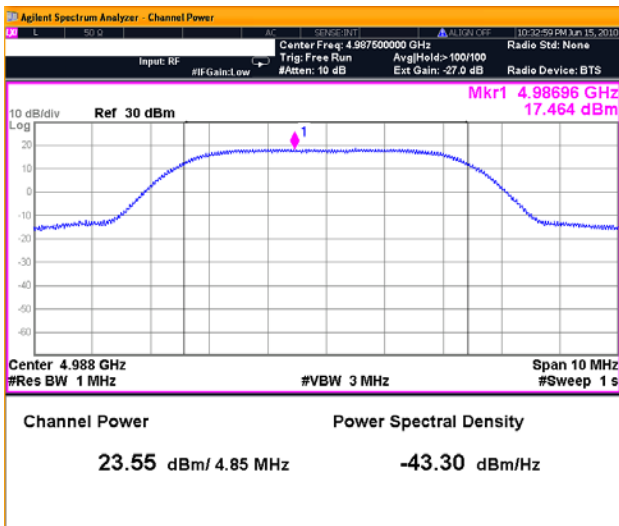

Plot # 6

Insertion loss of external attenuator, power splitter and cable = 27 dB.



Test report N: 9012332799/1
Title: BreezeMax Extreme CPE System 5.x
Model: XTRM-SU-OD-1D-4.9-2-A

FCC ID: LKT-EXTR-CPE-50

10 MHz EBW option, 99% bandwidth

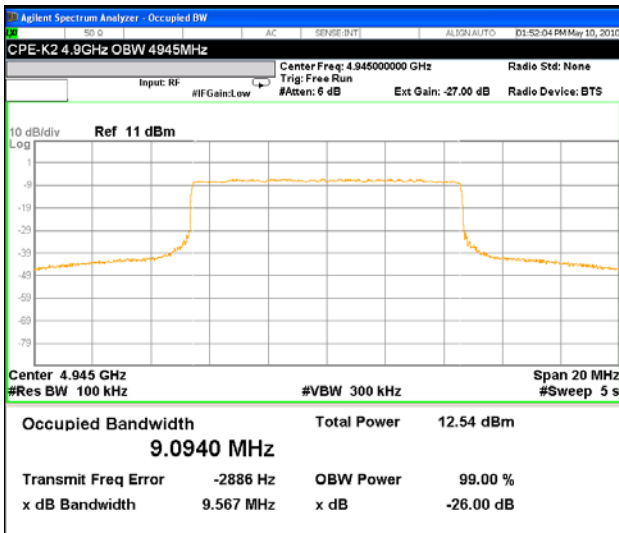

Plot # 7

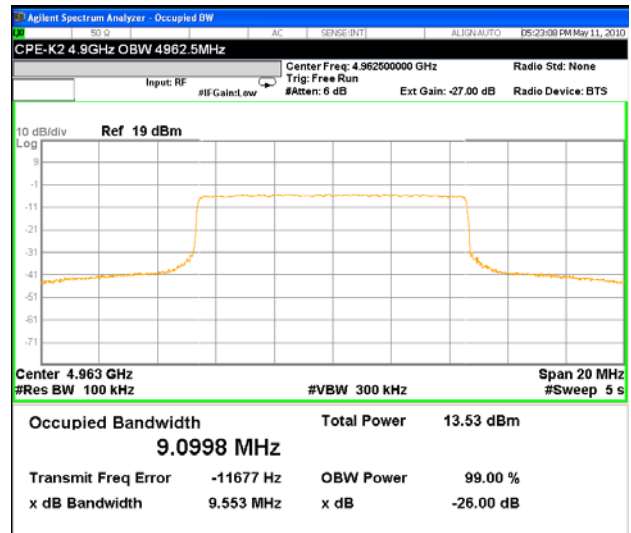

Plot # 8

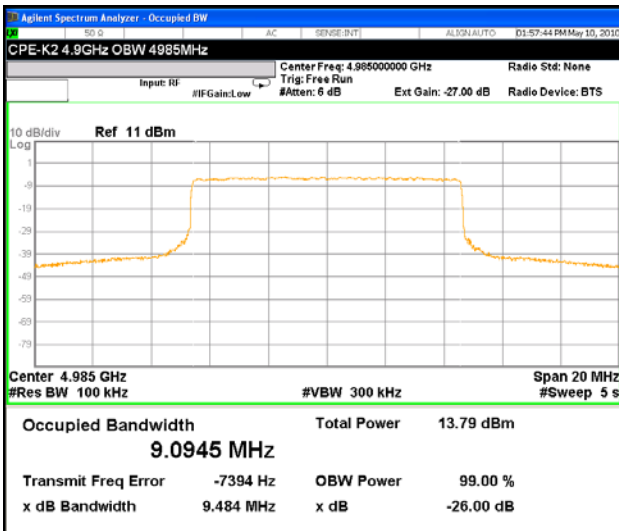

Plot # 9



Test report N: 9012332799/1
Title: BreezeMax Extreme CPE System 5.x
Model: XTRM-SU-OD-1D-4.9-2-A

Page 10 of 49

FCC ID: LKT-EXTR-CPE-50

10 MHz EBW option. Peak output power results

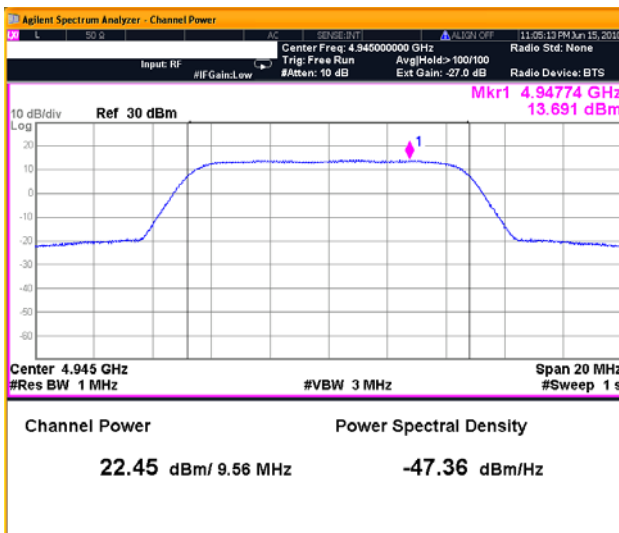

Plot # 10

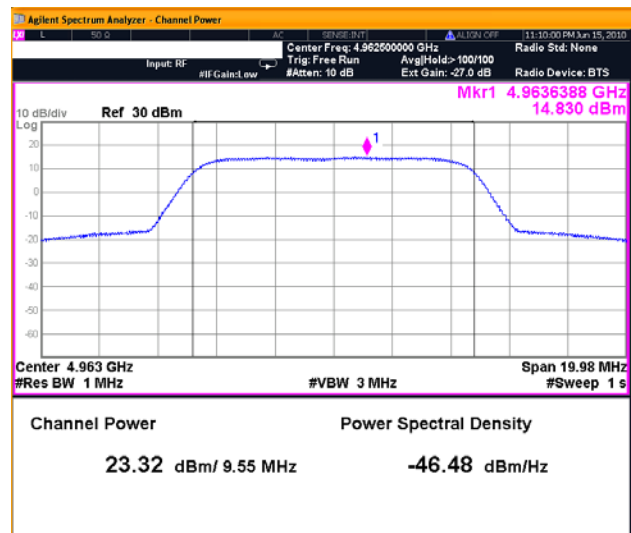

Plot # 11

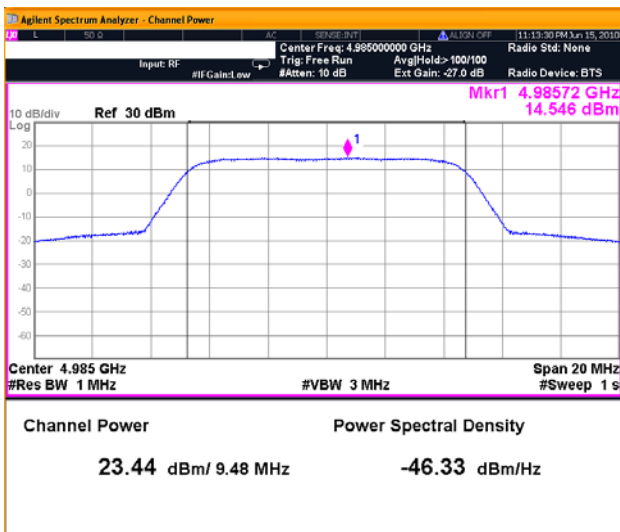

Plot # 12

Insertion loss of external attenuator, power splitter and cable = 27 dB



Test report N: 9012332799/1
Title: BreezeMax Extreme CPE System 5.x
Model: XTRM-SU-OD-1D-4.9-2-A

Page 11 of 49

FCC ID: LKT-EXTR-CPE-50**7.1.2 Peak power spectral density test according to §90.1215(a).**

Method of measurement FCC p.90.1215 (d)
 Operating Frequency Range 4942.5 – 4987.5 MHz
 Ambient Temperature 22⁰ C Relative Humidity 50% Air Pressure 1010 hPa

EBW, MHz	Carrier frequency, MHz	Measured PSD, dBm/MHz	Power spectral density limit dBm/MHz	Margin, dB	Reference to plots #
5.0	4942.5	16.6	21.0	4.4	4
	4962.5	17.6	21.0	3.4	5
	4987.5	17.4	21.0	3.6	6
10.0	4945.0	13.7	21.0	7.3	10
	4962.5	14.8	21.0	6.2	11
	4985.0	14.5	21.0	6.5	12

LIMIT

The high power devices are limited to a peak power spectral density of 21 dBm/MHz.

TEST PROCEDURE

The measurements were performed in normal (transmitting) mode of operation for carrier (channel) frequency at bottom, middle and the top of the 4940 - 4990 MHz frequency band under maximum data transfer bit rate. The EUT RF output was connected to the Spectrum Analyzer through appropriate attenuator and accounted with cable loss in SA settings.

TEST EQUIPMENT USED:

2	3	4	5	11		
---	---	---	---	----	--	--



Test report N: 9012332799/1
Title: BreezeMax Extreme CPE System 5.x
Model: XTRM-SU-OD-1D-4.9-2-A

FCC ID: LKT-EXTR-CPE-50

7.1.3 Power spectral density mask according to §90.210(m).

Method of measurement	FCC part 90.210 (m)(7)		
Operating Frequency Range	4942.5 – 4987.5 MHz		
Ambient Temperature	22 ⁰ C	Relative Humidity	50%
		Air Pressure	1010 hPa

LIMIT

Test was performed according to limitation of part 90.210 emission mask M.
The power spectral density of any emissions must be attenuated below the output power of the transmitter as follows:

- On any frequency removed from assigned frequency between 0 – 45% - 0 dB
- On any frequency removed from assigned frequency between 45 – 50% - 26dB
- On any frequency removed from assigned frequency between 50 – 55% - 32 dB
- On any frequency removed from assigned frequency between 55 – 100% - 40 dB
- On any frequency removed from assigned frequency between 100 – 150% -50 dB

TEST PROCEDURE

The measurements were performed in normal (transmitting) mode of operation for carrier (channel) frequencies at bottom, middle and the top of the 4940 - 4990 MHz frequency band under maximum data transfer bit rate. The EUT RF output was connected to the Spectrum Analyzer through appropriate attenuator and accounted with cable loss in SA settings. The emission mask measurements were performed with RBW = at least 1% of EBW and VBW = 30 kHz.

TEST SUMMARY

Transmitter complies with standard requirements.

TEST EQUIPMENT USED:

3	4	5	11			
---	---	---	----	--	--	--



Test report N: 9012332799/1
Title: BreezeMax Extreme CPE System 5.x
Model: XTRM-SU-OD-1D-4.9-2-A

FCC ID: LKT-EXTR-CPE-50

5 MHz emission bandwidth

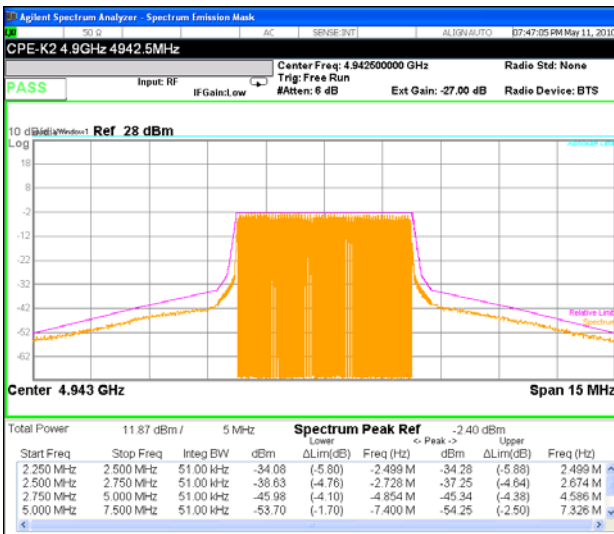

Plot # 13

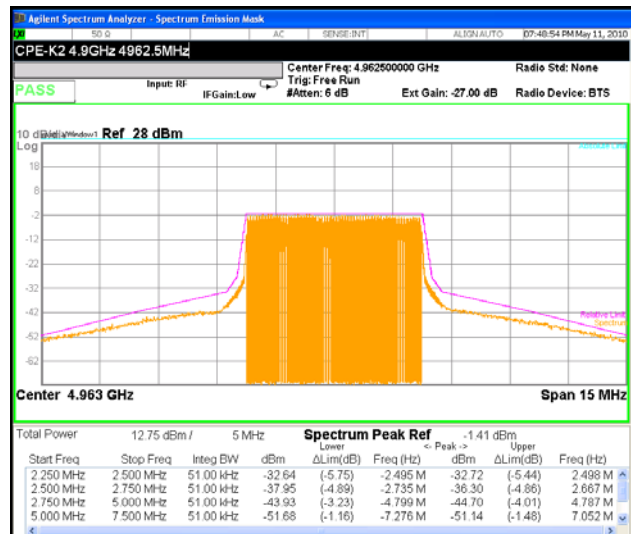

Plot # 14

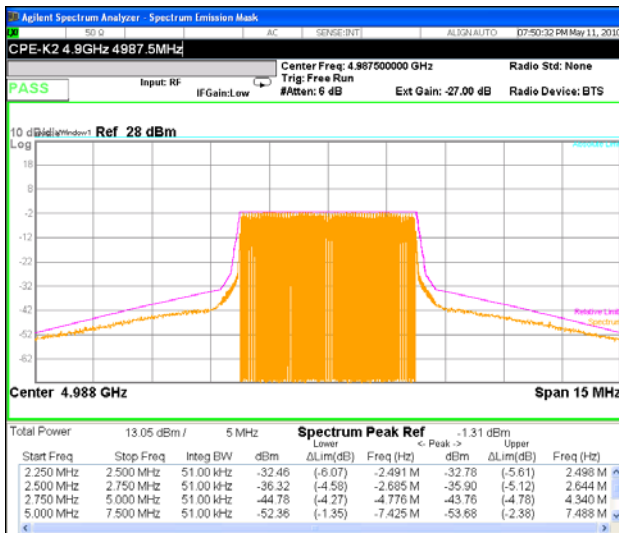

Plot # 15



Test report N: 9012332799/1
Title: BreezeMax Extreme CPE System 5.x
Model: XTRM-SU-OD-1D-4.9-2-A

FCC ID: LKT-EXTR-CPE-50

10 MHz emission bandwidth

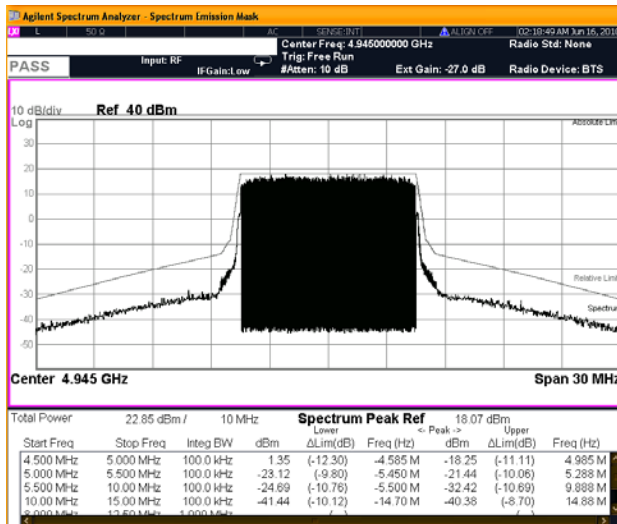

Plot # 16

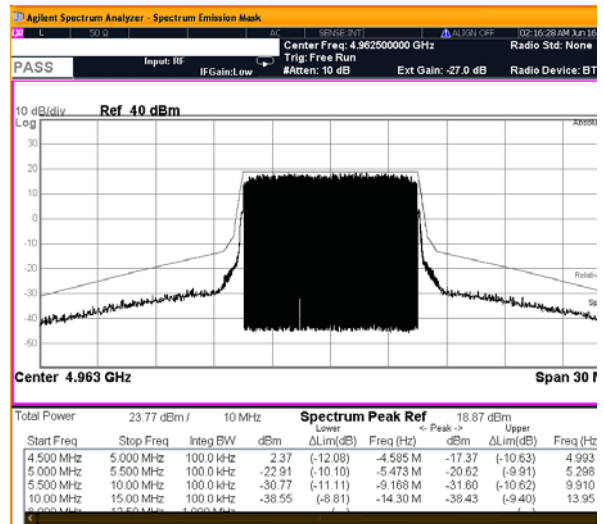

Plot # 17

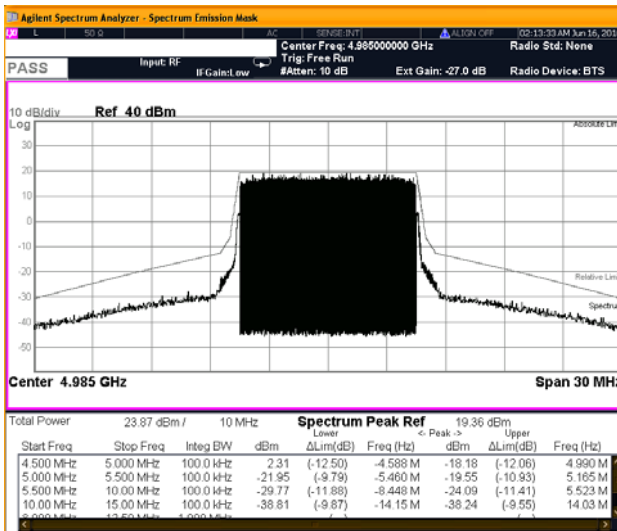

Plot # 18

**Test report N: 9012332799/1****Page 15 of 49****Title: BreezeMax Extreme CPE System 5.x****Model: XTRM-SU-OD-1D-4.9-2-A****FCC ID: LKT-EXTR-CPE-50****7.1.4 Undesired conducted emissions test according to § 90.210 m**

Method of measurement	FCC part 90.210 (m)(7)
Operating Frequency Range	4942.5 – 4987.5 MHz
Ambient Temperature	22 ^o C
Relative Humidity	50%
Air Pressure	1010 hPa

The frequency spectrum was investigated from the lowest radio frequency signal generated in the equipment, without going below 9 kHz and up to 40 GHz. No emissions were found except band-edge points. The emission levels of the EUT in peak mode more than 20 dB lower than the specified limit were not recorded in the table. For the test results refer to plots ## 19-48 in this section.

The worse case results were found:

EBW, MHz	Carrier frequency, MHz	Measured frequency, MHz	Measured level, dBm	Relative 48 dBc limit, dBm	Margin, dB	Reference to plot #
5.0	4942.5	4934.9	-36.1	-34.3	1.8	21
		4950	-36.8	-34.3	2.5	22
	4962.5	4954.8	-35.1	-33.2	1.9	26
		4970.2	-34.5	-33.2	1.3	27
	4987.5	4979.7	-36.0	-34.0	2.0	31
		4995.2	-36.0	-34.0	2.0	32
10.0	4945	4929.6	-41.1	-37.0	4.1	36
		4960.1	-41.3	-37.0	4.3	37
	4962.5	4947.1	-37.8	-36.0	1.8	41
		4977.8	-39.5	-36.0	3.5	42
	4985	4969.8	-38.1	-36.3	1.8	46
		5000.3	-40.5	-36.3	4.2	47

LIMIT

The power spectral density of any emissions must be attenuated below the output power of the transmitter as follow: On any frequency removed from assigned frequency above 150% - $55+10 \text{ Log (P)} = 55+10 \text{ Log (23 dBm)} = 48 \text{ dB}$. Calculation was performed as follow: $U_{\text{carrier peak}} - 48 \text{ dB}$.



Test report N: 9012332799/1
Title: BreezeMax Extreme CPE System 5.x
Model: XTRM-SU-OD-1D-4.9-2-A

Page 16 of 49

FCC ID: LKT-EXTR-CPE-50

TEST PROCEDURE

The measurements were performed in normal (transmitting) mode of operation for carrier (channel) frequency at bottom, middle and the top of the 4940 - 4990 MHz frequency band under maximum data transfer bit rate. The EUT RF output was connected to the Spectrum Analyzer through appropriate attenuator and accounted with cable loss in SA settings. The measurements were performed with RBW = at least 1% of EBW and VBW = 30 kHz.

TEST EQUIPMENT USED:

1	3	5				
---	---	---	--	--	--	--



Test report N: 9012332799/1
Title: BreezeMax Extreme CPE System 5.x
Model: XTRM-SU-OD-1D-4.9-2-A

FCC ID: LKT-EXTR-CPE-50

5 MHz emission bandwidth. Carrier frequency 4942.5 MHz.

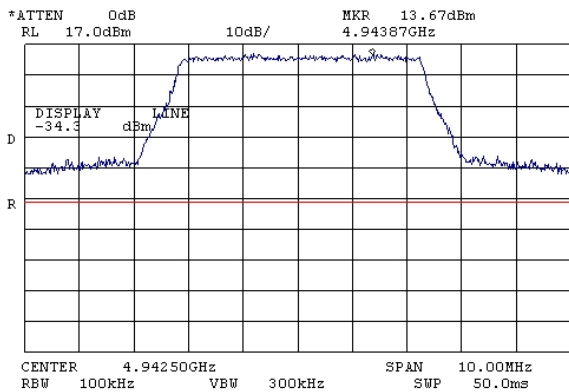

Plot # 19.

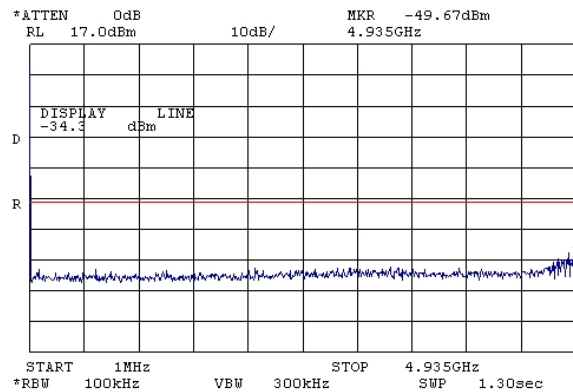

Plot # 20

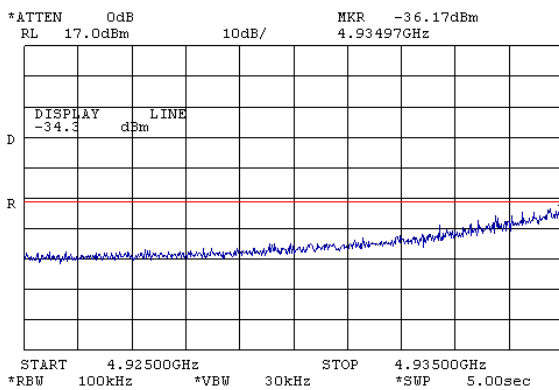

Plot # 21.

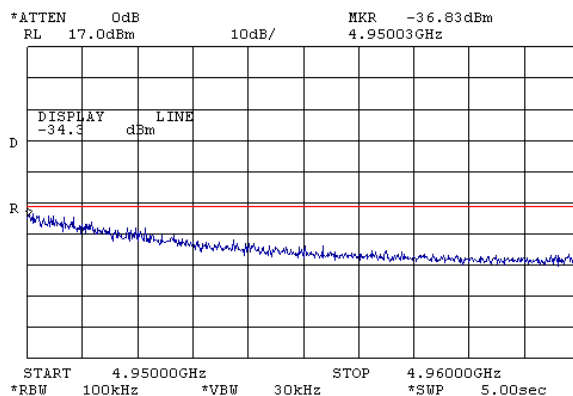

Plot # 22.

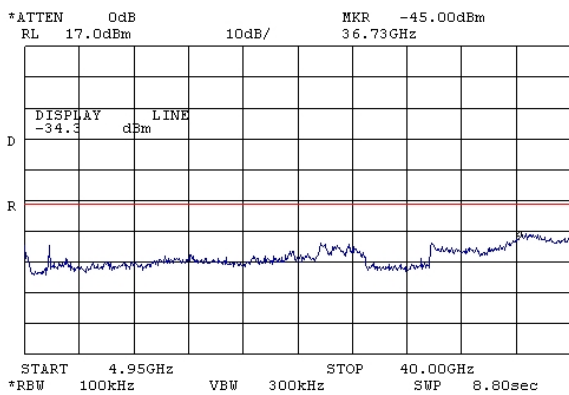

Plot # 23.



Test report N: 9012332799/1
Title: BreezeMax Extreme CPE System 5.x
Model: XTRM-SU-OD-1D-4.9-2-A

FCC ID: LKT-EXTR-CPE-50

5 MHz emission bandwidth. Carrier frequency 4962.5 MHz.

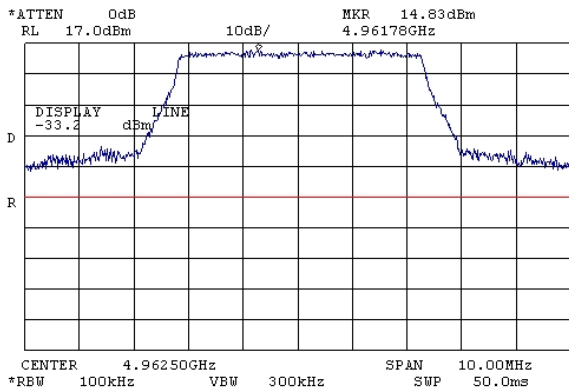

Plot # 24.

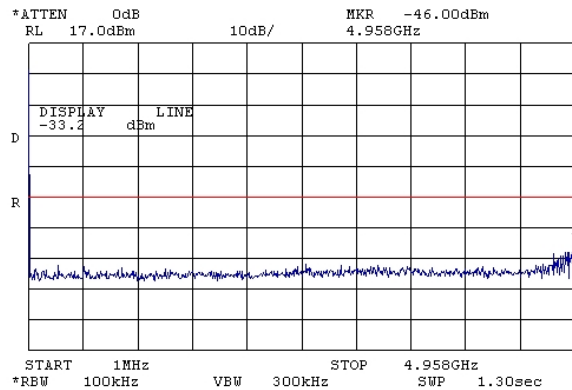

Plot # 25

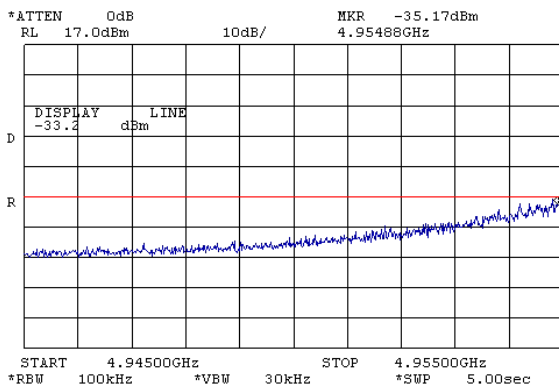

Plot # 26.

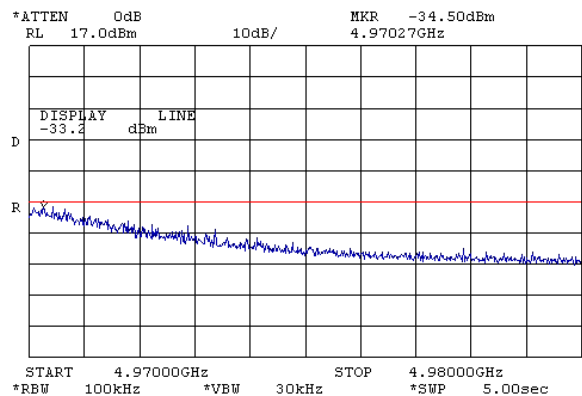

Plot # 27.

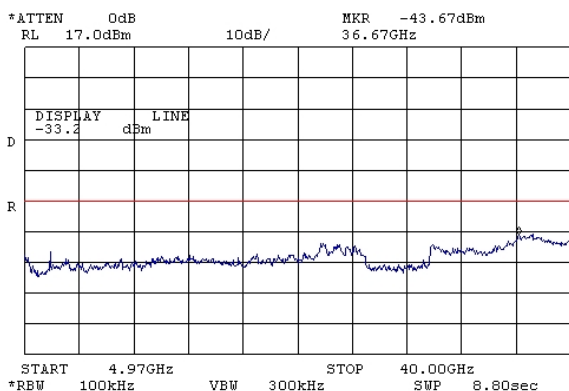

Plot # 28.



Test report N: 9012332799/1
Title: BreezeMax Extreme CPE System 5.x
Model: XTRM-SU-OD-1D-4.9-2-A

FCC ID: LKT-EXTR-CPE-50

5 MHz emission bandwidth. Carrier frequency 4987.5 MHz

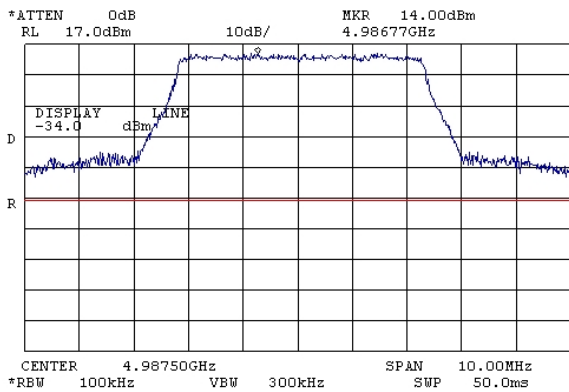

Plot # 29.

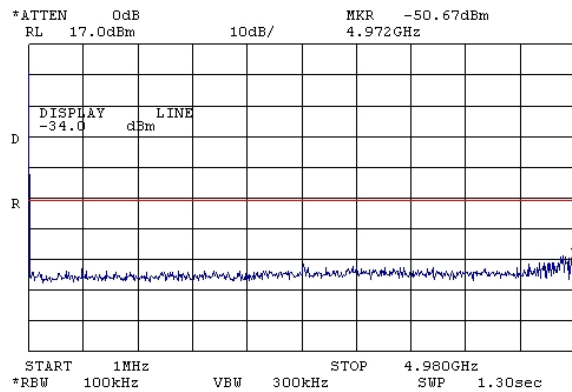

Plot # 30

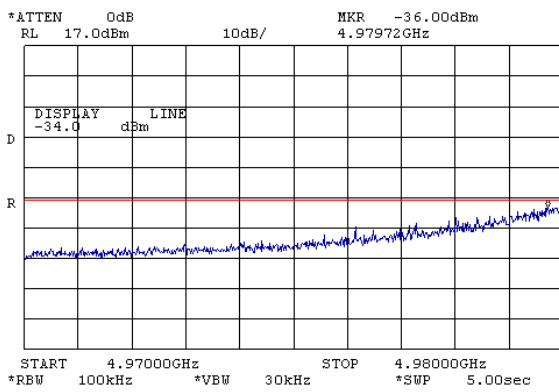

Plot # 31.

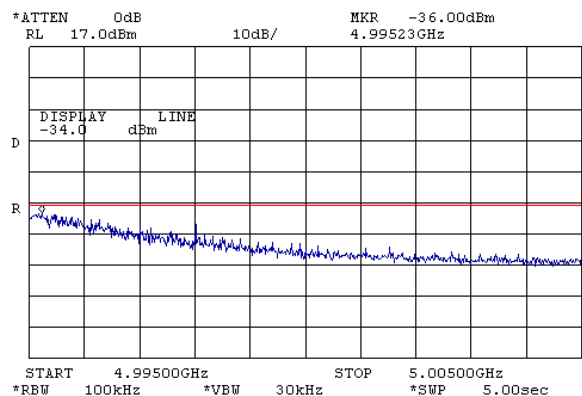

Plot # 32.

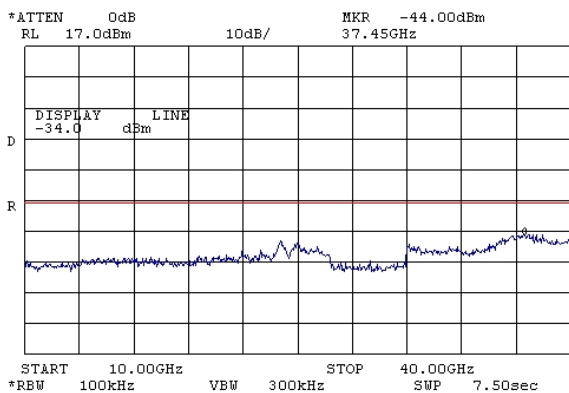

Plot # 33.



Test report N: 9012332799/1
Title: BreezeMax Extreme CPE System 5.x
Model: XTRM-SU-OD-1D-4.9-2-A

FCC ID: LKT-EXTR-CPE-50

10 MHz emission bandwidth. Carrier frequency 4945 MHz

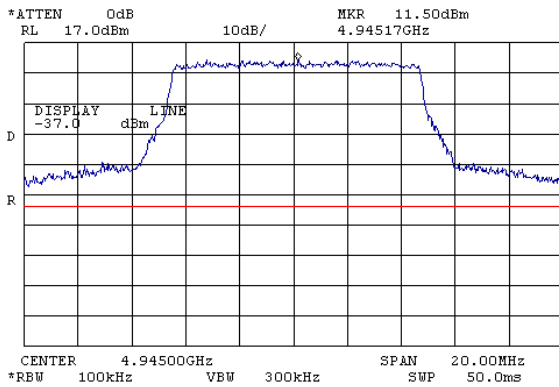

Plot # 34.

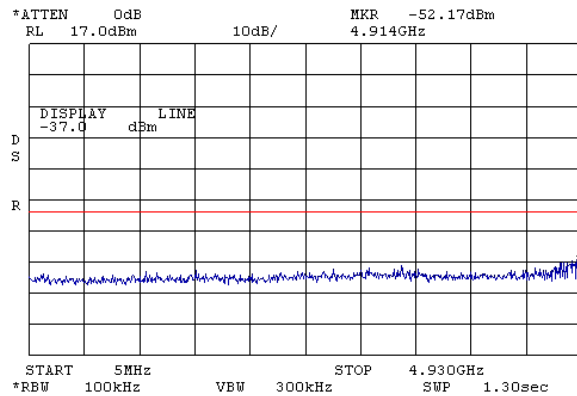

Plot # 35

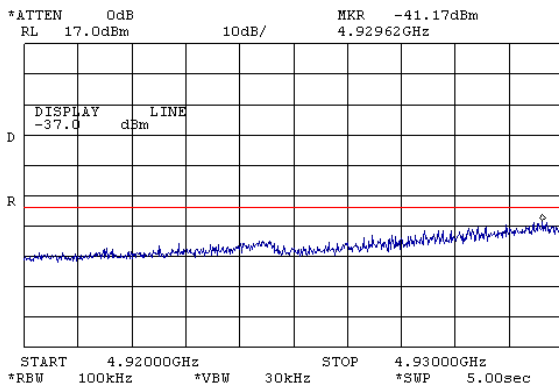

Plot # 36.

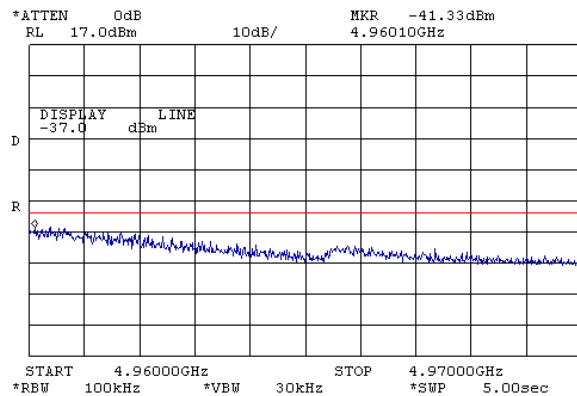

Plot # 37.

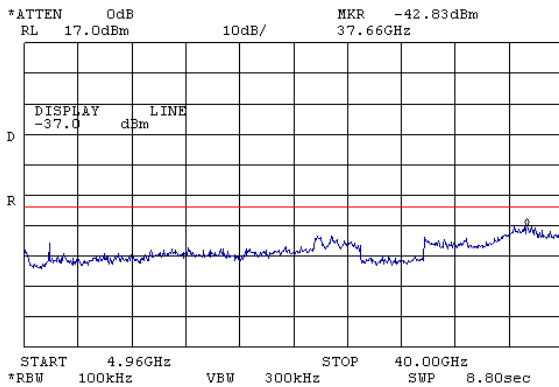

Plot # 38.



Test report N: 9012332799/1
Title: BreezeMax Extreme CPE System 5.x
Model: XTRM-SU-OD-1D-4.9-2-A

FCC ID: LKT-EXTR-CPE-50

10 MHz emission bandwidth. Carrier frequency 4962.5 MHz

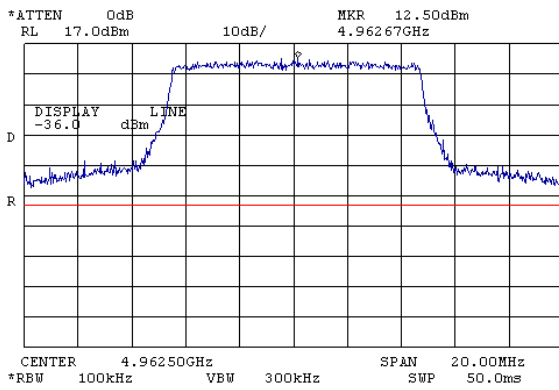

Plot # 39.

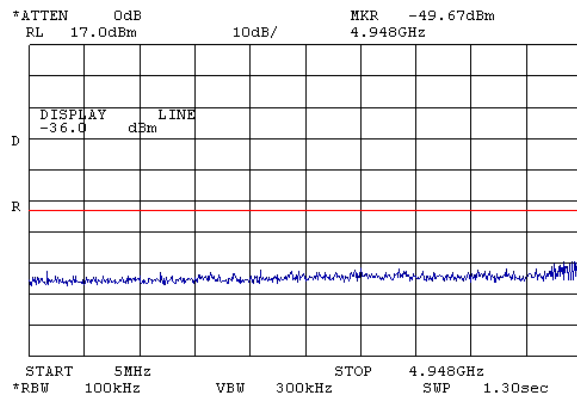

Plot # 40

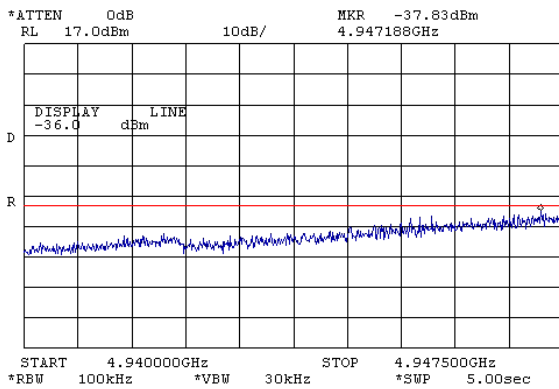

Plot # 41.

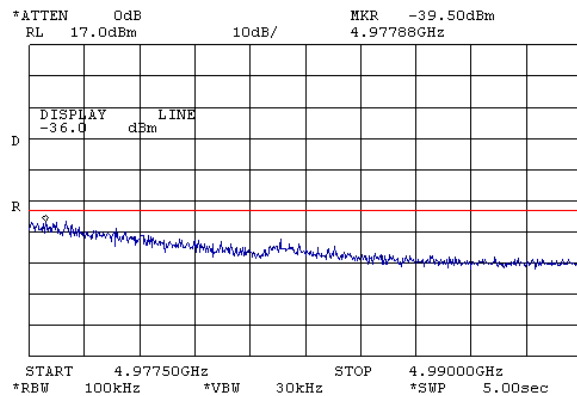

Plot # 42.

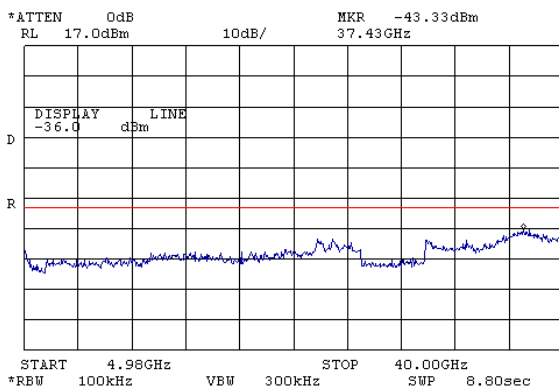

Plot # 43.



Test report N: 9012332799/1
Title: BreezeMax Extreme CPE System 5.x
Model: XTRM-SU-OD-1D-4.9-2-A

FCC ID: LKT-EXTR-CPE-50

10 MHz emission bandwidth. Carrier frequency 4985 MHz

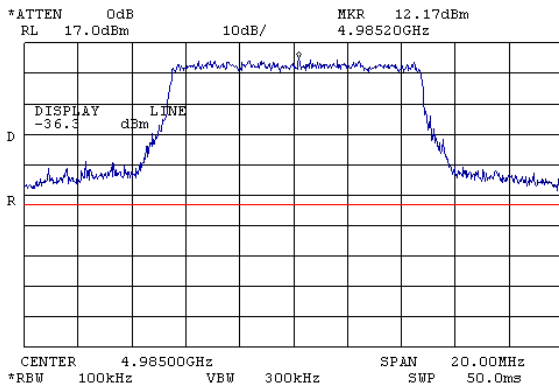

Plot # 44.

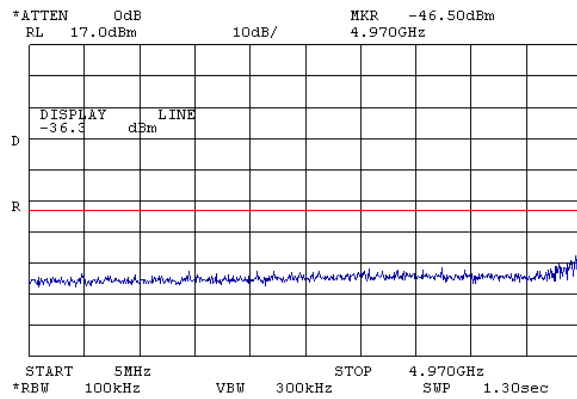

Plot # 45.

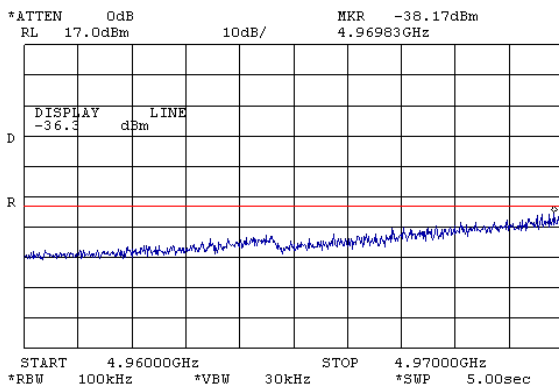

Plot # 46.

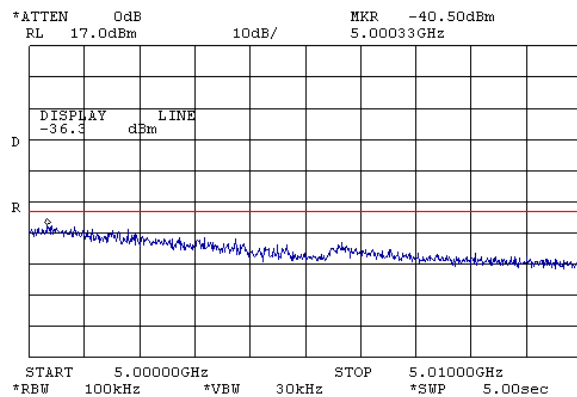

Plot # 47.

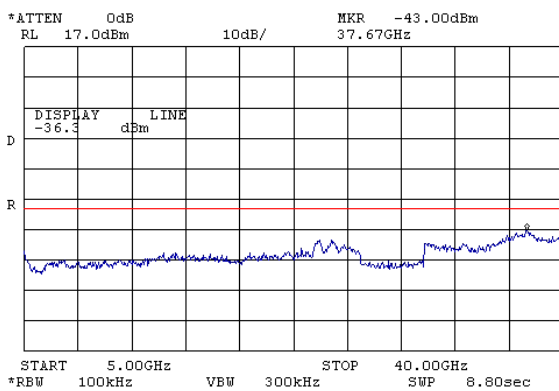

Plot # 48.

Test report N: 9012332799/1

Page 23 of 49

Title: BreezeMax Extreme CPE System 5.x

Model: XTRM-SU-OD-1D-4.9-2-A

FCC ID: LKT-EXTR-CPE-50

7.1.5 Undesired radiated emissions test according to § 90.210 (m).

Method of measurement FCC part 90.210 (m)(7)
 Operating Frequency Range 4942.5 – 4987.5 MHz
 Ambient Temperature 22° C Relative Humidity 50% Air Pressure 1010 hPa

The frequency spectrum was investigated from the lowest radio frequency signal generated in the equipment, without going below 9 kHz and up to 40 GHz. The emission levels of the EUT more than 20 dB lower than the specified limit were not recorded in the test summary. For the worse case results refer to the tables and plots in this section.

EBW, MHz	Carrier frequency, MHz	Measured frequency, MHz	Measured level, dBm	Relative 48.5 dBc limit, dBm	Margin, dB	Reference to plot #
5.0	4942.5	4934.9	-27.4	-25.2	2.2	52
		4950.1	-27.4	-25.2	2.2	53
	4962.5	4954.7	-28.9	-27.8	1.1	60
		4970.4	-28.7	-27.8	0.9	61
	4987.5	4979.6	-30.1	-27.6	2.5	68
		4995.1	-29.4	-27.6	1.8	69
10.0	4945	4929.3	-32.2	-30.2	2.0	76
		4960.0	-32.3	-30.2	2.1	77
	4962.5	4947.3	-30.4	-29.0	1.4	84
		4977.5	-30.9	-29.0	1.9	85
	4985	4969.6	-30.6	-29.4	1.2	92
		5000.7	-32.0	-29.4	2.6	93

LIMIT

The power spectral density of any emissions must be attenuated below the output power of the transmitter as follow: On any frequency removed from assigned frequency above 150% - $55+10 \text{ Log (P)} = 55+10 \text{ Log (23.5 dBm)} = 48.5 \text{ dB}$. Calculation was performed as follow: $U_{\text{carrier peak}} - 48.5 \text{ dB}$. Relative limit for every carrier frequency was calculated from maximum measured power result 23.5 dBm as a worse case attenuated limit.



Test report N: 9012332799/1
Title: BreezeMax Extreme CPE System 5.x
Model: XTRM-SU-OD-1D-4.9-2-A

Page 24 of 49

FCC ID: LKT-EXTR-CPE-50

TEST PROCEDURE

The test was performed for two emission bandwidths. The measurements were performed at three transmitted carrier (channel) frequencies at bottom, middle and top of the 4940 - 4990 MHz frequency band under maximum data transfer bit rate. To find maximum radiation the turntable was rotated 360°, measuring antenna height was changed from 1 to 4 m, and the antenna polarization was changed from vertical to horizontal. The measurements were performed according to FCC part 90.210 m (7) with RBW = at least 1% of EBW and VBW = 30 kHz. The result was previously verified according to ANSI/TIA-603-C-2004 section 2.2.12 substitution test method. Investigation of transmitter spurious emissions was performed. EUT was replaced by generator and substitution antenna. The level calculated from generator output level, substitution antenna gain and connected cable loss was compared with the limit.

TEST SUMMARY

EUT comply with FCC part 90.210 (m) requirements.

TEST EQUIPMENT USED:

1	5	6	7	9	10	14	15	16
---	---	---	---	---	----	----	----	----



Test report N: 9012332799/1
Title: BreezeMax Extreme CPE System 5.x
Model: XTRM-SU-OD-1D-4.9-2-A

FCC ID: LKT-EXTR-CPE-50

5 MHz EBW

Carrier frequency – 4942.5 MHz

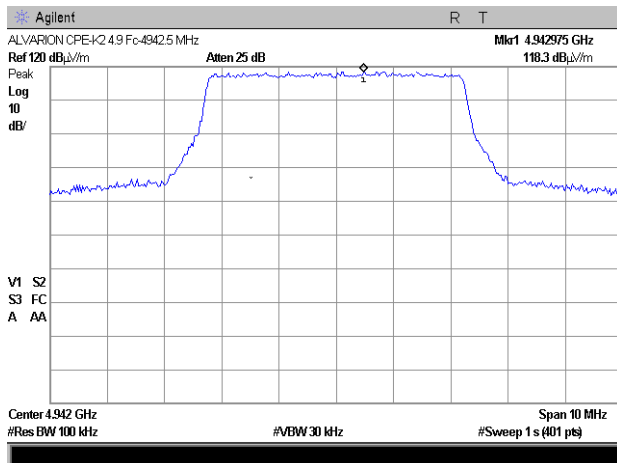

Plot # 49

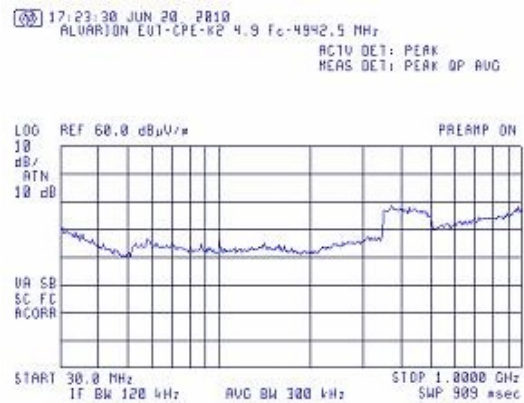

Plot # 50

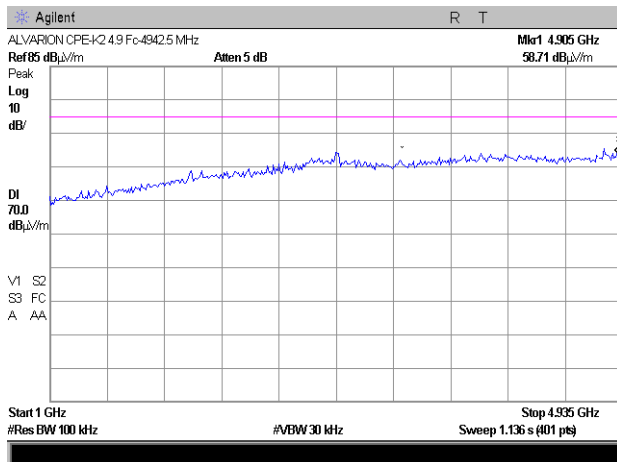

Plot # 51

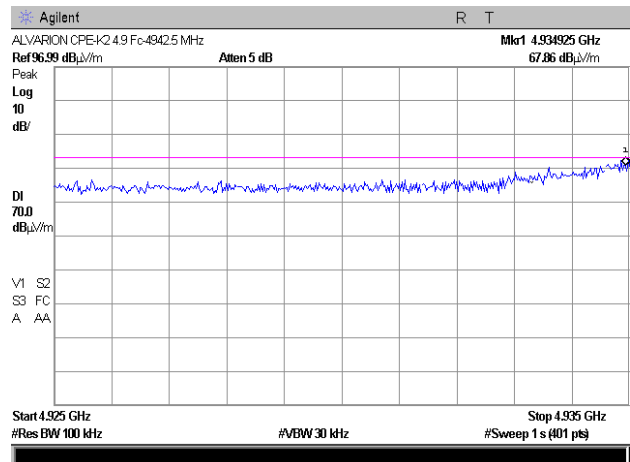

Plot # 52



Test report N: 9012332799/1
Title: BreezeMax Extreme CPE System 5.x
Model: XTRM-SU-OD-1D-4.9-2-A

FCC ID: LKT-EXTR-CPE-50

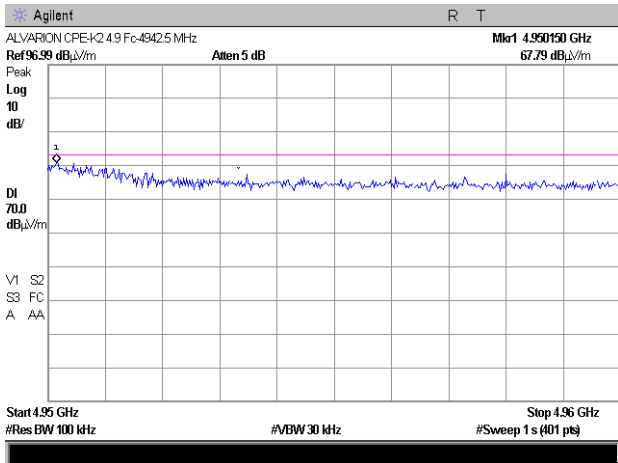

Plot # 53

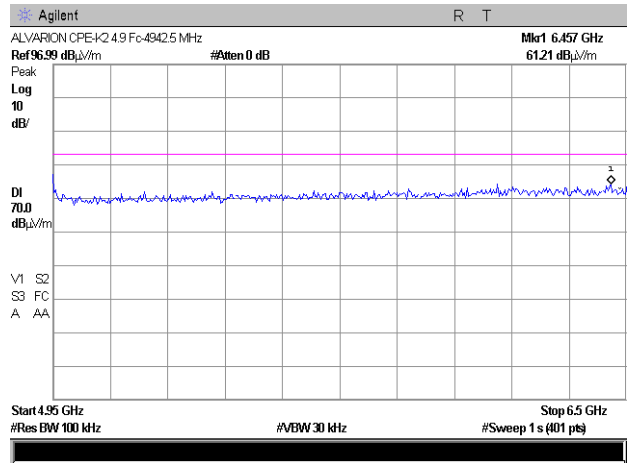

Plot # 54

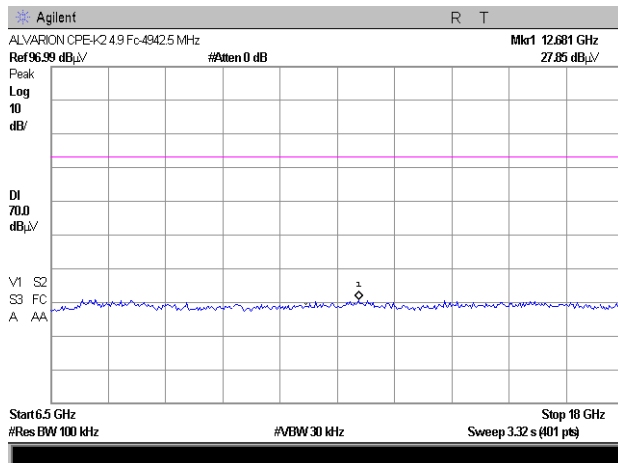

Plot # 55

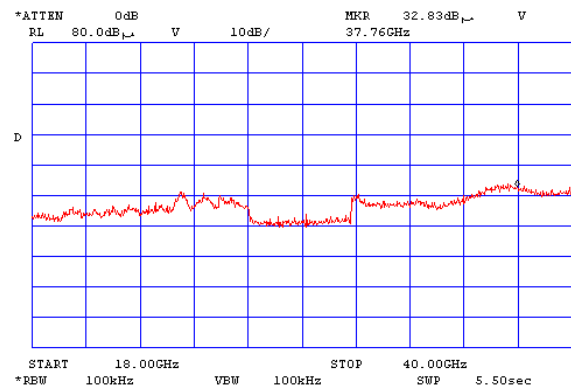

Plot # 56



Test report N: 9012332799/1
Title: BreezeMax Extreme CPE System 5.x
Model: XTRM-SU-OD-1D-4.9-2-A

FCC ID: LKT-EXTR-CPE-50

Carrier frequency – 4962.5 MHz

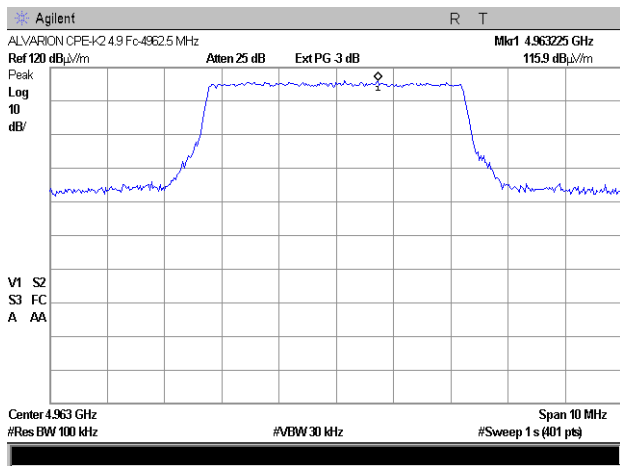

Plot # 57

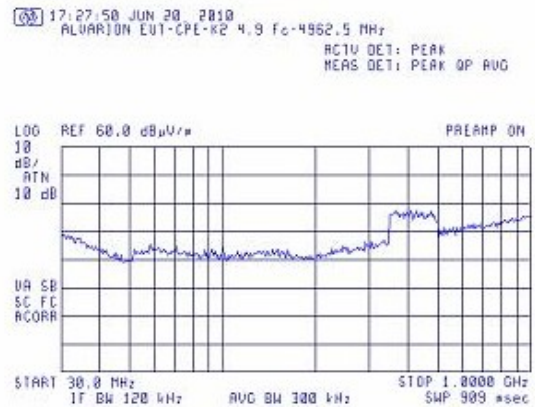

Plot # 58

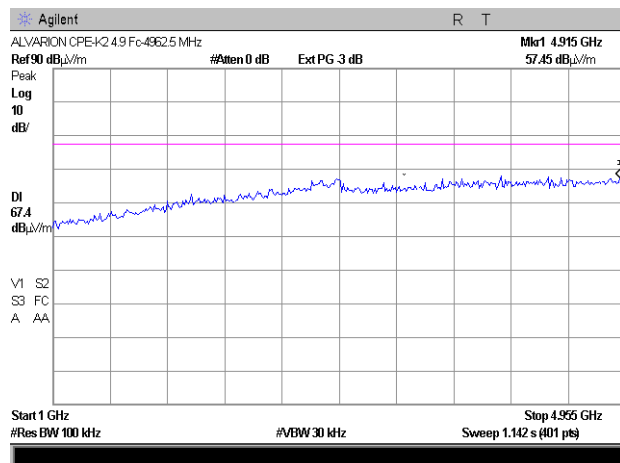

Plot # 59

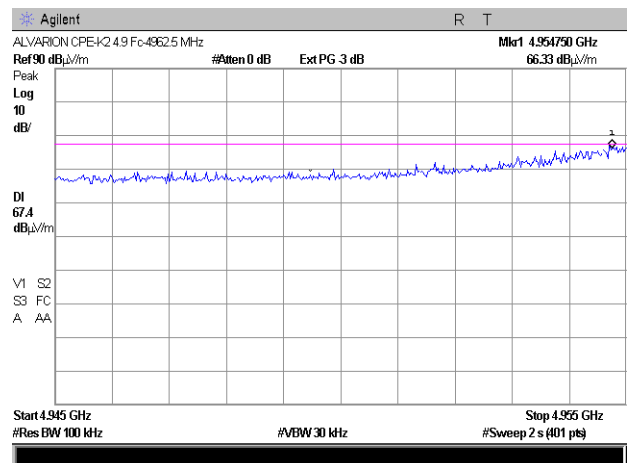

Plot # 60



Test report N: 9012332799/1
Title: BreezeMax Extreme CPE System 5.x
Model: XTRM-SU-OD-1D-4.9-2-A

FCC ID: LKT-EXTR-CPE-50

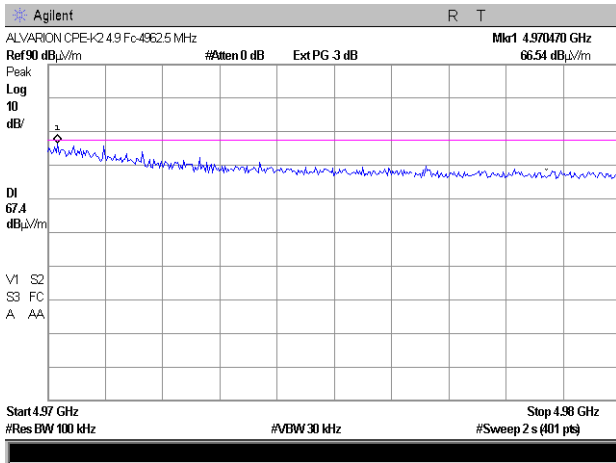

Plot # 61

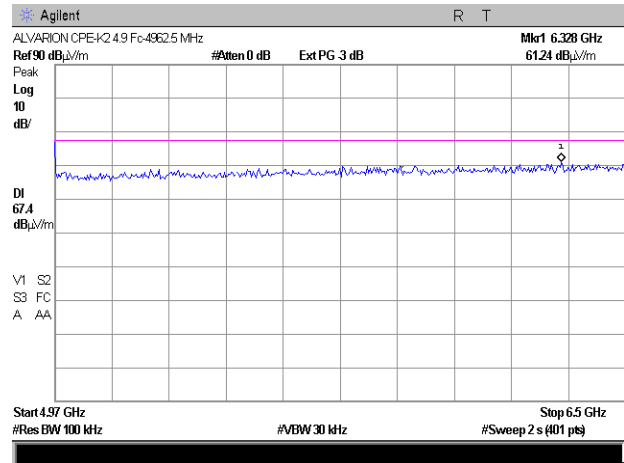

Plot # 62

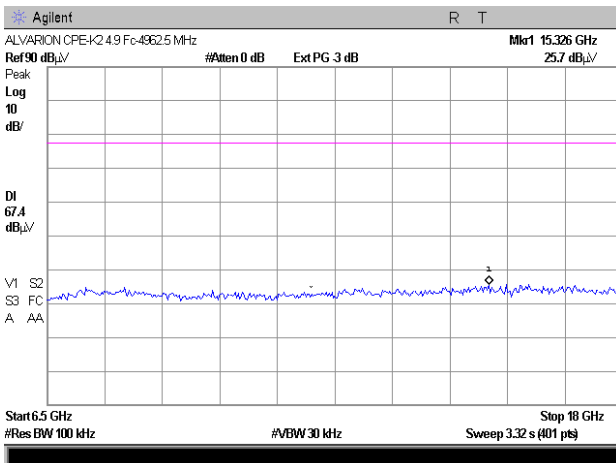

Plot # 63

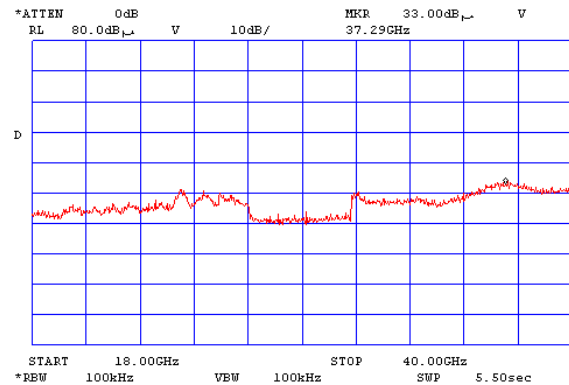

Plot # 64



Test report N: 9012332799/1
Title: BreezeMax Extreme CPE System 5.x
Model: XTRM-SU-OD-1D-4.9-2-A

FCC ID: LKT-EXTR-CPE-50

Carrier frequency – 4987.5 MHz

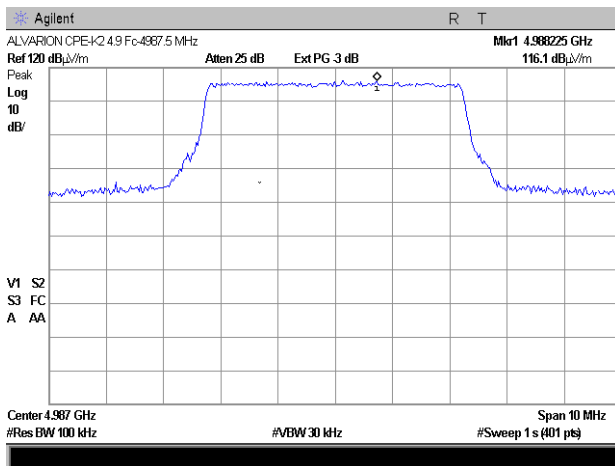

Plot # 65

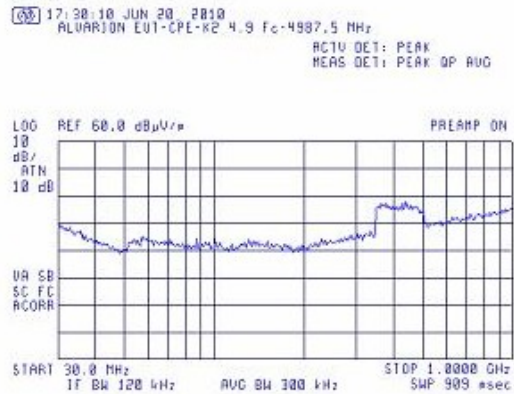

Plot # 66

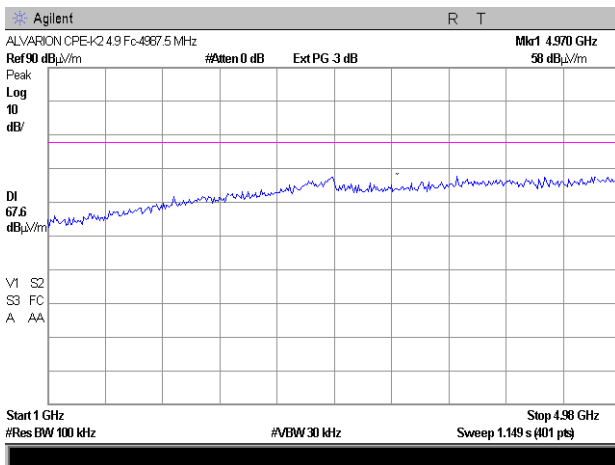

Plot # 67

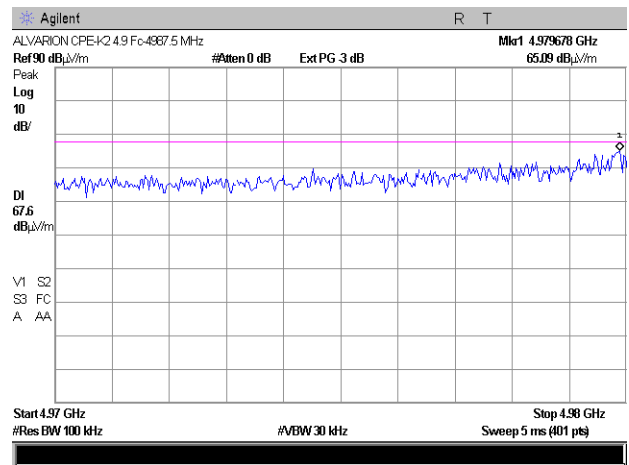

Plot # 68



Test report N: 9012332799/1
Title: BreezeMax Extreme CPE System 5.x
Model: XTRM-SU-OD-1D-4.9-2-A

FCC ID: LKT-EXTR-CPE-50

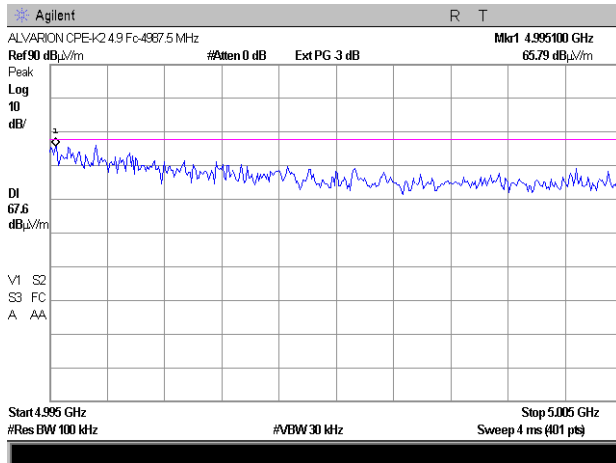

Plot # 69

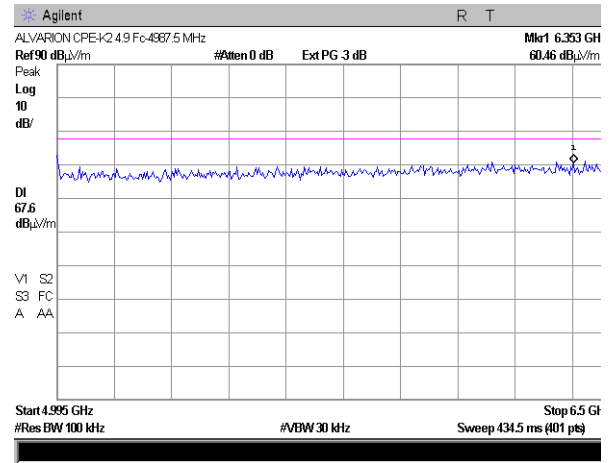

Plot # 70

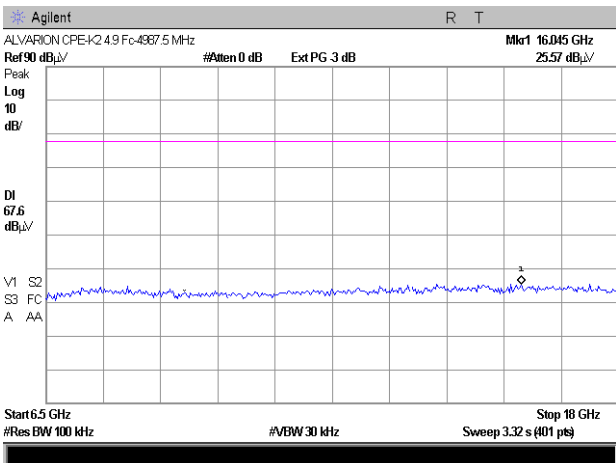

Plot # 71

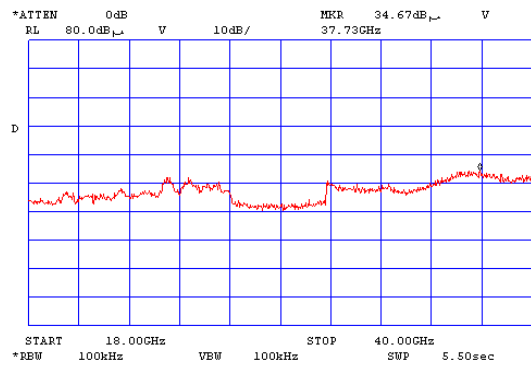

Plot # 72



Test report N: 9012332799/1
Title: BreezeMax Extreme CPE System 5.x
Model: XTRM-SU-OD-1D-4.9-2-A

FCC ID: LKT-EXTR-CPE-50

10 MHz EBW.

Carrier frequency – 4945 MHz

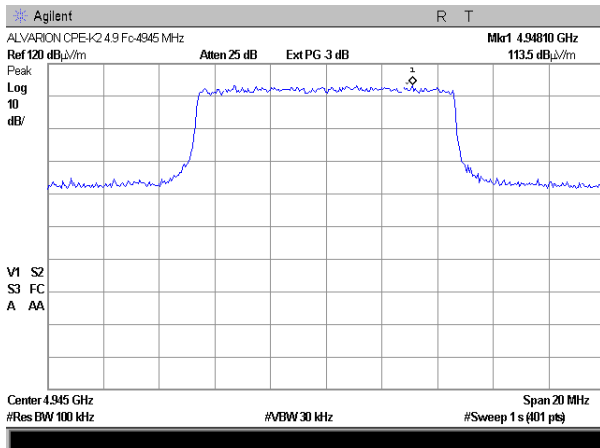

Plot # 73

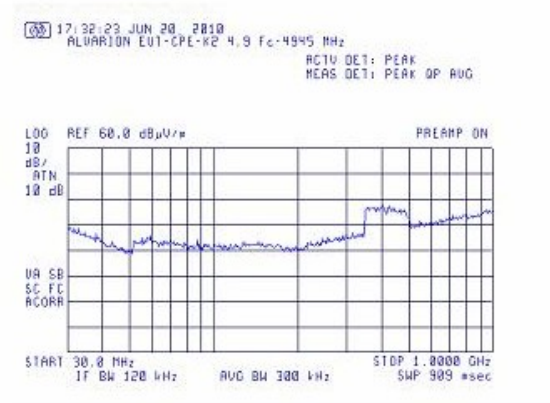

Plot # 74

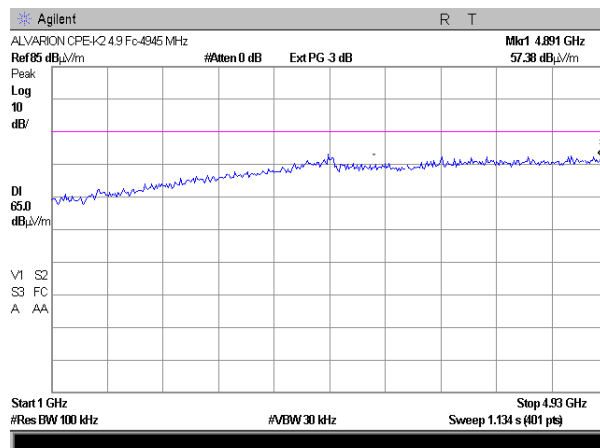

Plot # 75

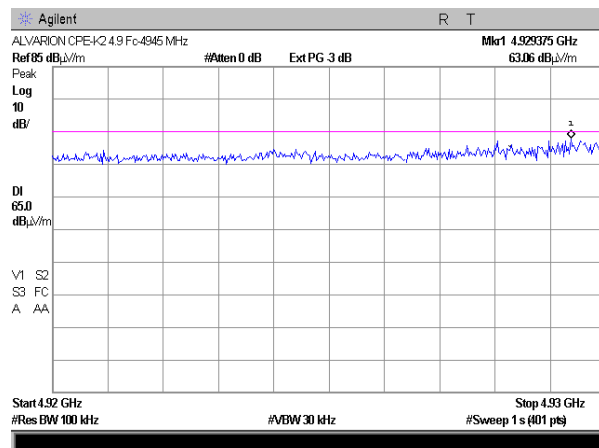

Plot # 76



Test report N: 9012332799/1
Title: BreezeMax Extreme CPE System 5.x
Model: XTRM-SU-OD-1D-4.9-2-A

FCC ID: LKT-EXTR-CPE-50

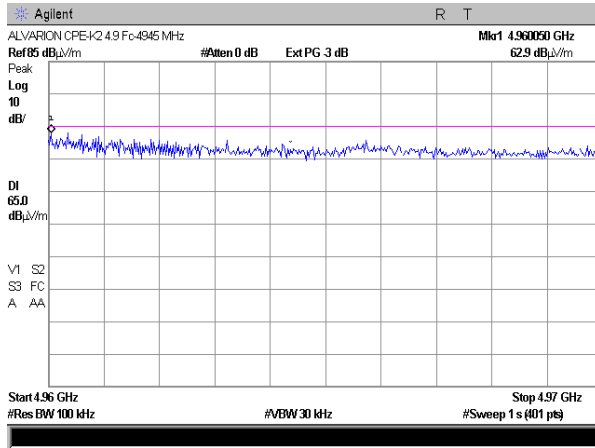

Plot # 77

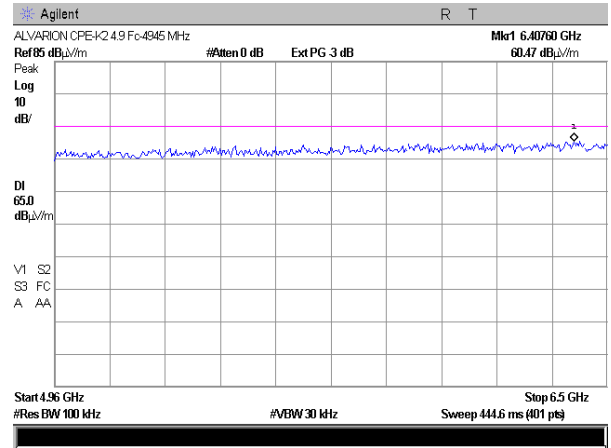

Plot # 78

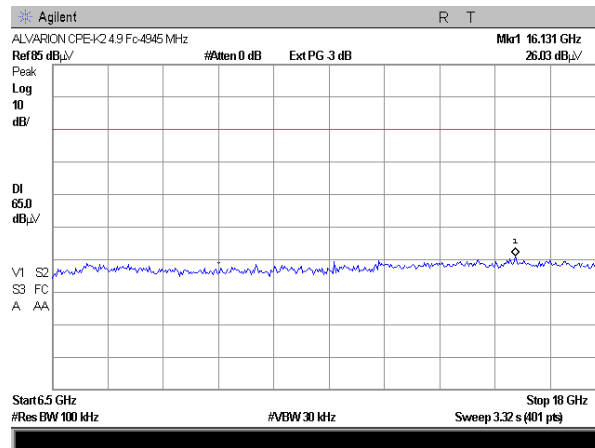

Plot # 79

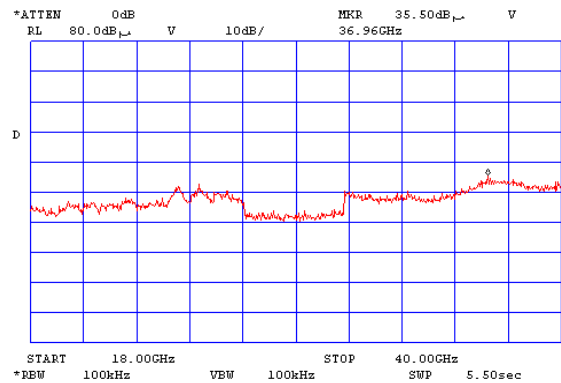

Plot # 80



Test report N: 9012332799/1
Title: BreezeMax Extreme CPE System 5.x
Model: XTRM-SU-OD-1D-4.9-2-A

FCC ID: LKT-EXTR-CPE-50

Carrier frequency – 4962.5 MHz

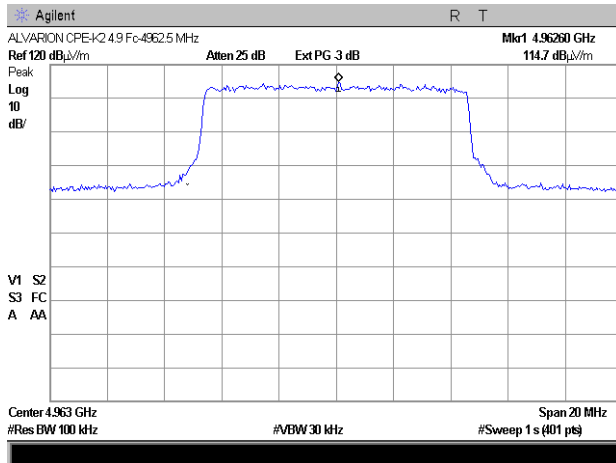

Plot # 81

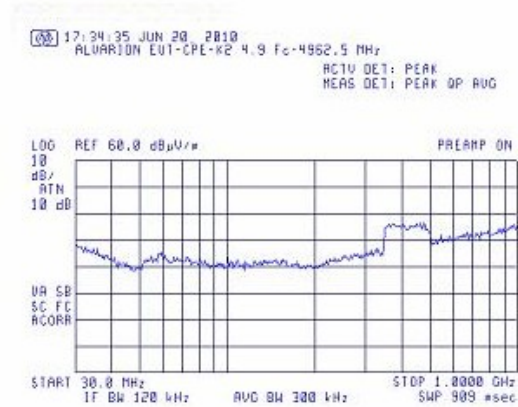

Plot # 82

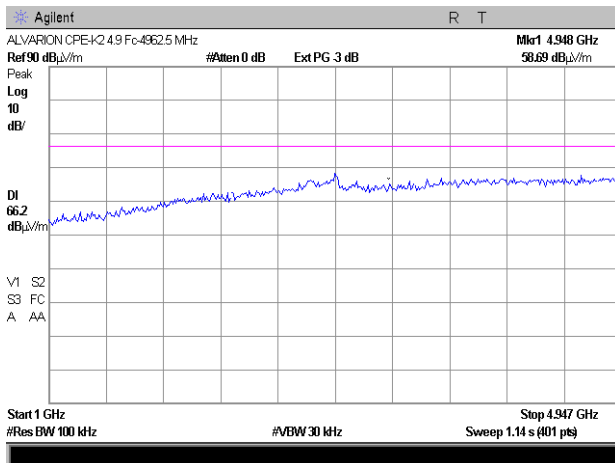

Plot # 83

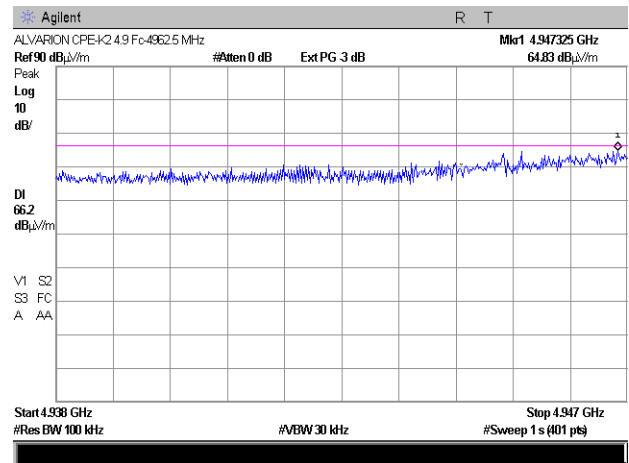

Plot # 84



Test report N: 9012332799/1
Title: BreezeMax Extreme CPE System 5.x
Model: XTRM-SU-OD-1D-4.9-2-A

FCC ID: LKT-EXTR-CPE-50

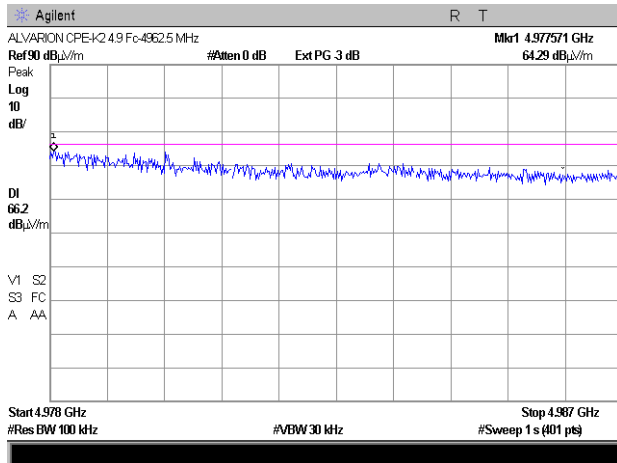

Plot # 85

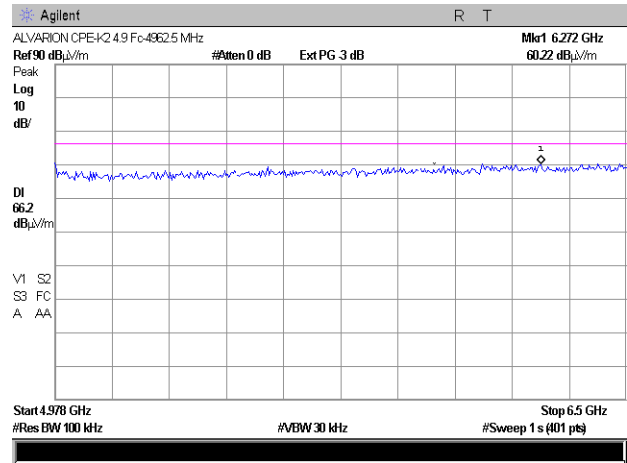

Plot # 86

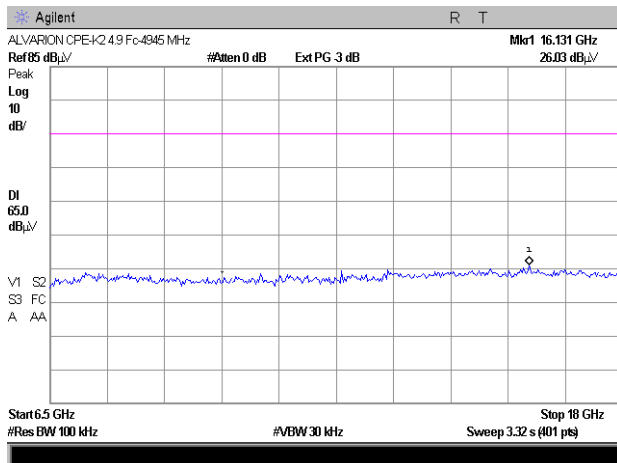

Plot # 87

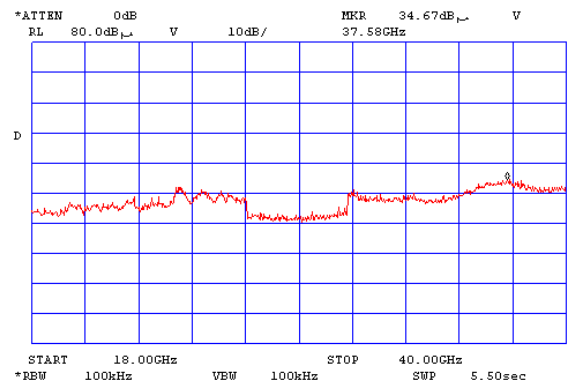

Plot # 88



Test report N: 9012332799/1
Title: BreezeMax Extreme CPE System 5.x
Model: XTRM-SU-OD-1D-4.9-2-A

FCC ID: LKT-EXTR-CPE-50

Carrier frequency 4985 MHz

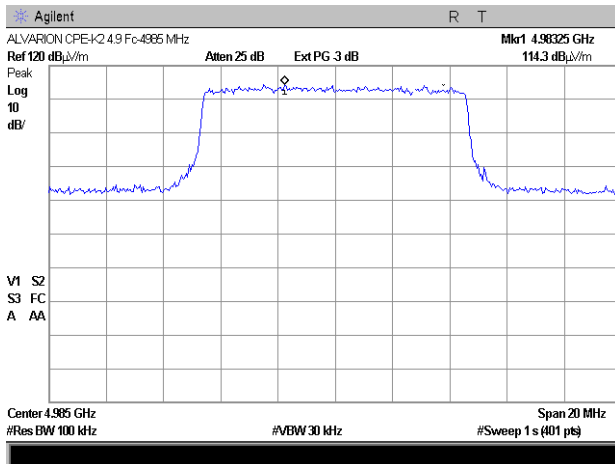

Plot # 89

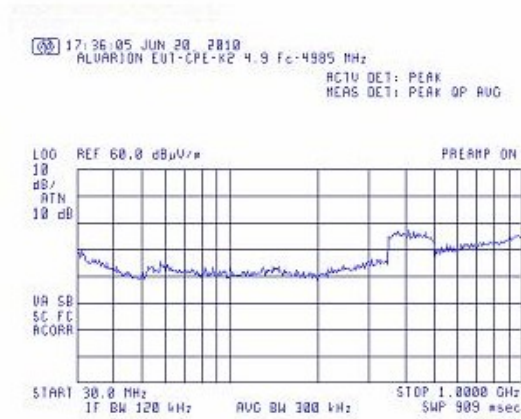

Plot # 90

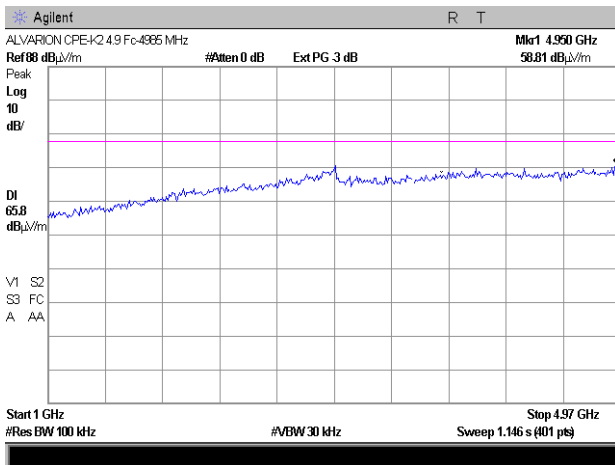

Plot # 91

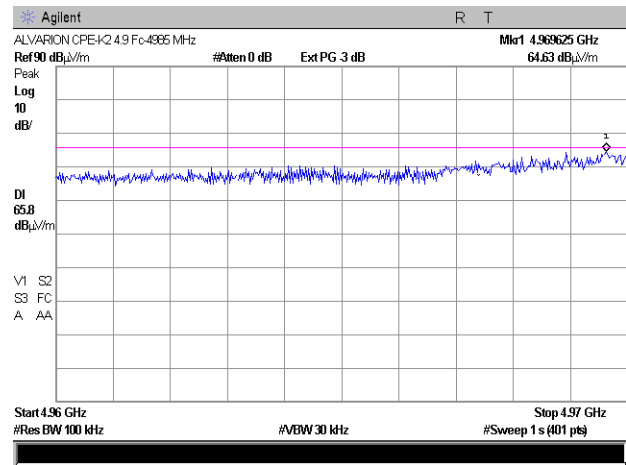

Plot # 92



Test report N: 9012332799/1
Title: BreezeMax Extreme CPE System 5.x
Model: XTRM-SU-OD-1D-4.9-2-A

FCC ID: LKT-EXTR-CPE-50

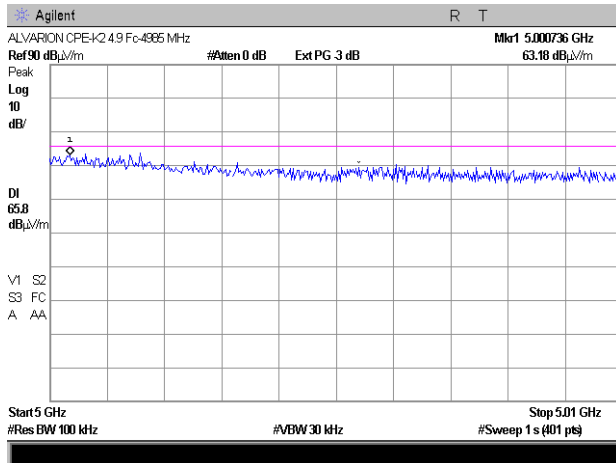

Plot # 93

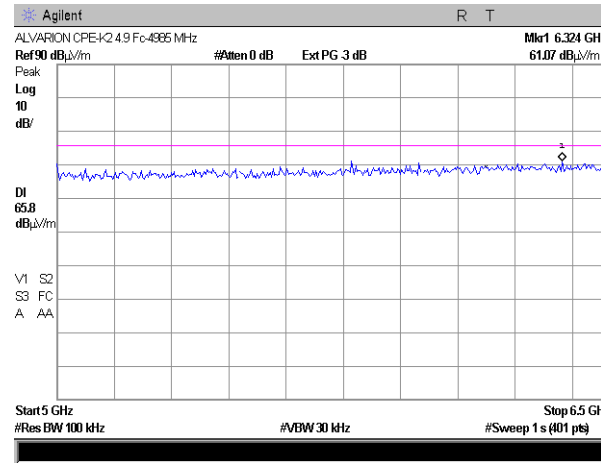

Plot # 94

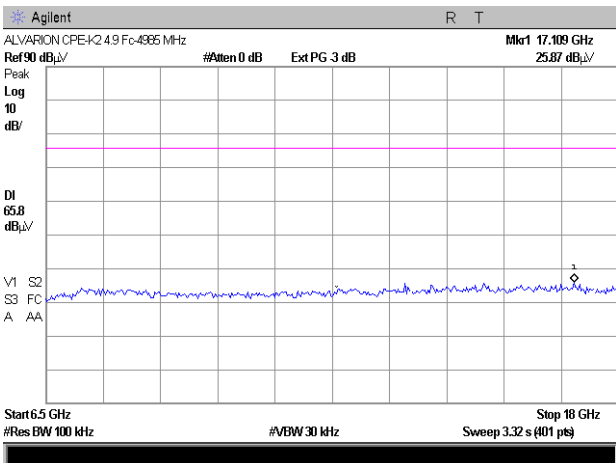

Plot # 95

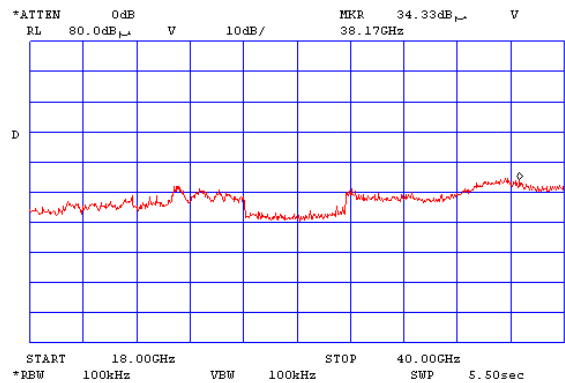

Plot # 96



Test report N: 9012332799/1
Title: BreezeMax Extreme CPE System 5.x
Model: XTRM-SU-OD-1D-4.9-2-A

FCC ID: LKT-EXTR-CPE-50

7.1.6 Ratio of the peak excursion per part 90.1215(e)

Method of measurement DA 02-2138
Operating Frequency Range 4942.5 – 4987.5 MHz
Ambient Temperature 22° C Relative Humidity 50% Air Pressure 1010 hPa

The measurements were performed for all emission bandwidth options at maximum allowed output power under maximum data transfer bit rate. The trace #1 was performed with RBW= 1 MHz and VBW = 3 MHz. The trace #2 was performed with RBW= 1 MHz and VBW = 1 kHz. $VBW \geq 1/T = 1/1.64 \text{ ms} = 0.6 \text{ kHz}$ where T is transmission pulse duration from plot # 103.

5 MHz emission bandwidth

Carrier frequency MHz	Measured ratio dB	The limit of the ratio dB	Reference to plot #
4942.5	11.2	13.0	97
4962.5	11.1	13.0	98
4987.5	11.6	13.0	99

10 MHz emission bandwidth

Carrier frequency MHz	Measured ratio dB	The limit of the ratio dB	Reference to plot #
4945	12.3	13.0	100
4962.5	11.2	13.0	101
4985	12.4	13.0	102

REQUIREMENT

The ratio of the peak excursion of the modulation envelope to the peak transmit power shall not exceed 13 dB across any 1 MHz bandwidth or the emission bandwidth whichever is less as required in section 90.1215(e).

TEST SUMMARY

Transmitter meets standard requirement.
Test result present in plots ## 97 - 99 for 5 MHz emission bandwidth.
Test result present in plots ## 100 - 102 for 10 MHz emission bandwidth.

TEST EQUIPMENT USED:

2	3	4	5			
---	---	---	---	--	--	--



Test report N: 9012332799/1
Title: BreezeMax Extreme CPE System 5.x
Model: XTRM-SU-OD-1D-4.9-2-A

Page 38 of 49

FCC ID: LKT-EXTR-CPE-50

5 MHz emission bandwidth

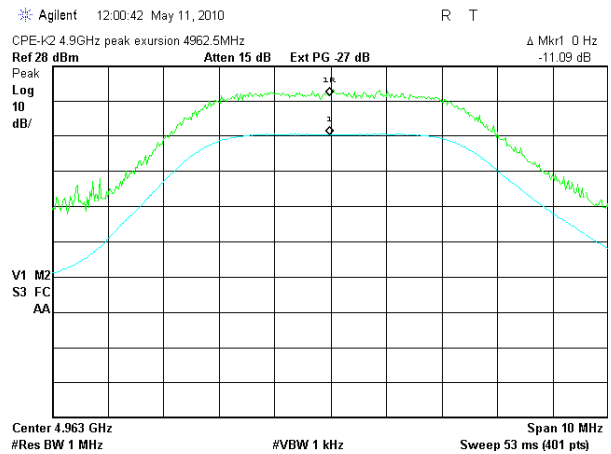
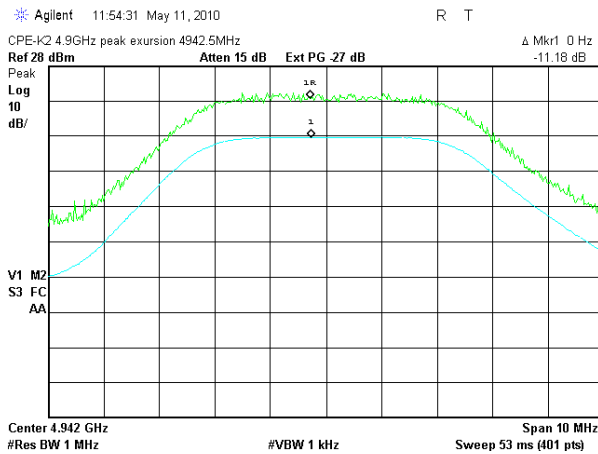

Plot # 97. Carrier frequency 4942.5 MHz

Plot # 98. Carrier frequency 4962.5 MHz

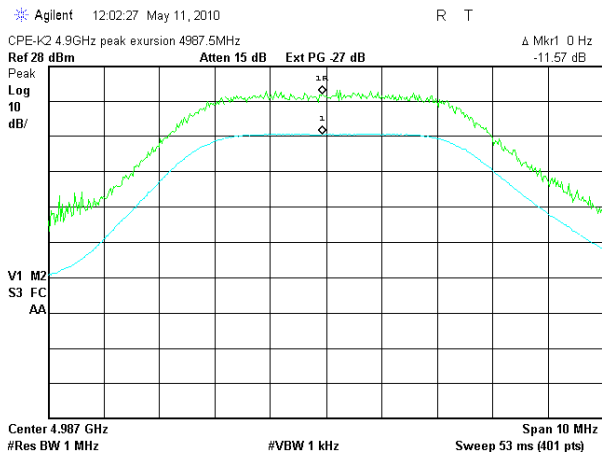

Plot # 99. Carrier frequency 4987.5 MHz



Test report N: 9012332799/1
Title: BreezeMax Extreme CPE System 5.x
Model: XTRM-SU-OD-1D-4.9-2-A

FCC ID: LKT-EXTR-CPE-50

10 MHz emission bandwidth

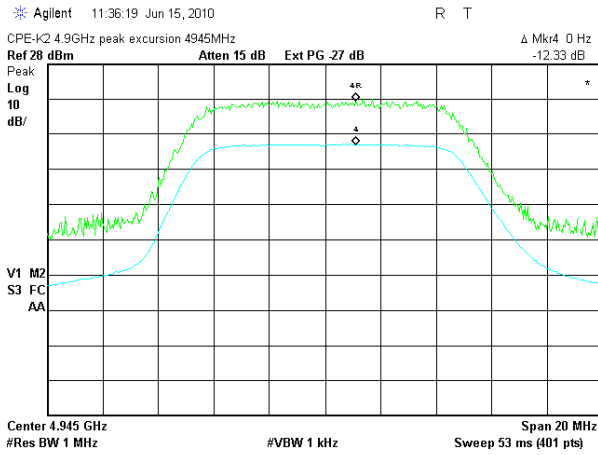

Plot # 100. Carrier frequency 4945 MHz

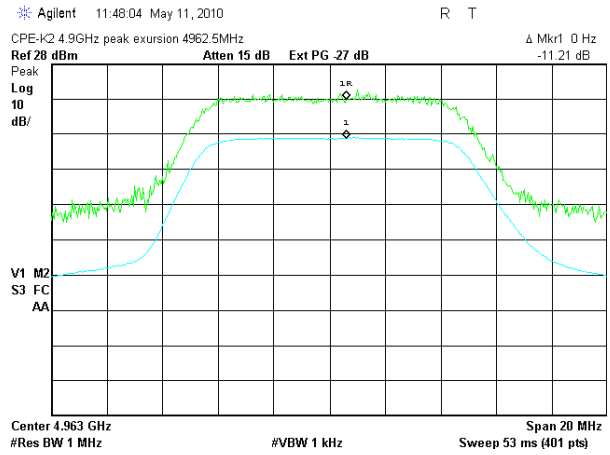

Plot # 101. Carrier frequency 4962.5 MHz

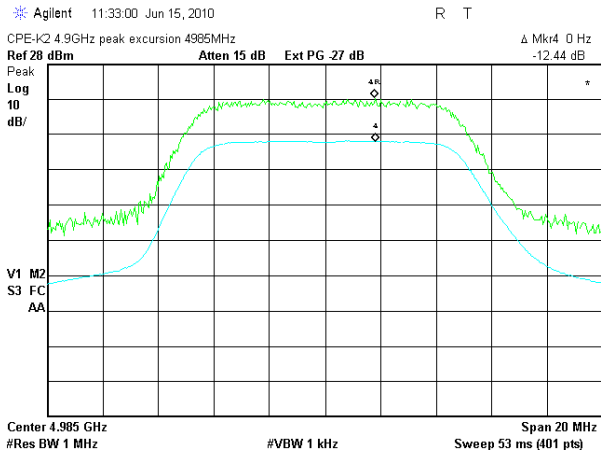

Plot # 102. Carrier frequency 4985 MHz



Test report N: 9012332799/1
Title: BreezeMax Extreme CPE System 5.x
Model: XTRM-SU-OD-1D-4.9-2-A

FCC ID: LKT-EXTR-CPE-50

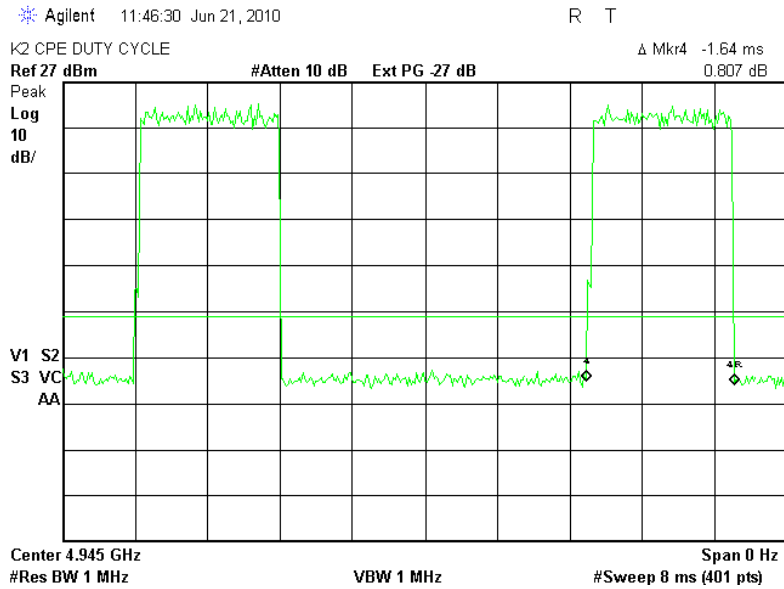

Plot # 103

Calculation of the used in trace two VBW performed as follow $1/T_{on} = 1/1.64 \text{ ms} = 0.6 \text{ kHz}$



Test report N: 9012332799/1

Page 41 of 49

Title: BreezeMax Extreme CPE System 5.x

Model: XTRM-SU-OD-1D-4.9-2-A

FCC ID: LKT-EXTR-CPE-50

7.1.7 Frequency stability according to § 90.213

Method of measurement FCC part 2.1055
 Operating Frequency Range 4942.5 – 4987.5 MHz
 Ambient Temperature 20° C Relative Humidity 54% Air Pressure 1007 hPa

TEST CONDITIONS		Transmitted frequency, 4945 MHz	Frequency deviation (ppm)	Transmitted frequency, 4985 MHz	Frequency deviation (ppm)
Test temperature	Test voltage(AC)				
20°C	Vmin (102)	4945.000680	0.14	4985.000700	0.14
	Vmax (138)	4945.000670	0.13	4985.000750	0.15
-30°C	Vnom (120)	4944.999450	-0.11	4984.999520	-0.10
-20°C	Vnom (120)	4944.999220	-0.16	4984.999180	-0.16
-10°C	Vnom (120)	4944.999620	-0.08	4984.999620	-0.08
+0°C	Vnom (120)	4945.000120	0.02	4985.000070	0.01
+10°C	Vnom (120)	4945.001850	0.37	4985.001910	0.38
+30°C	Vnom (120)	4945.002120	0.43	4985.002320	0.46
+40°C	Vnom (120)	4944.999020	-0.20	4984.000010	-0.20
+50°C	Vnom (120)	4944.999320	-0.14	4984.999290	-0.14

TEST PROCEDURE

The EUT was placed in a climatic chamber and allowed to stabilize at 20°C temperature and nominal voltage for at least 15 min. The reference carrier frequency result was taken. The input voltage was changed from 85% of nominal to 115%. Frequency changes were noted. The temperature in climatic chamber was varied from -30°C to +50°C. Measured frequencies were noted in the table above.

LIMIT

The frequency stability shall be sufficient to ensure that the fundamental emissions stay within the authorized frequency band of operation.

TEST SUMMARY

Transmitter carrier frequency stays within the authorized frequency band 4940 – 4990 MHz.

TEST EQUIPMENT USED:

2	3	14				
---	---	----	--	--	--	--

Test report N: 9012332799/1

Page 42 of 49

Title: BreezeMax Extreme CPE System 5.x

Model: XTRM-SU-OD-1D-4.9-2-A

FCC ID: LKT-EXTR-CPE-50

8. APPENDIX A



Photo #1. RF conducted emissions test setup.

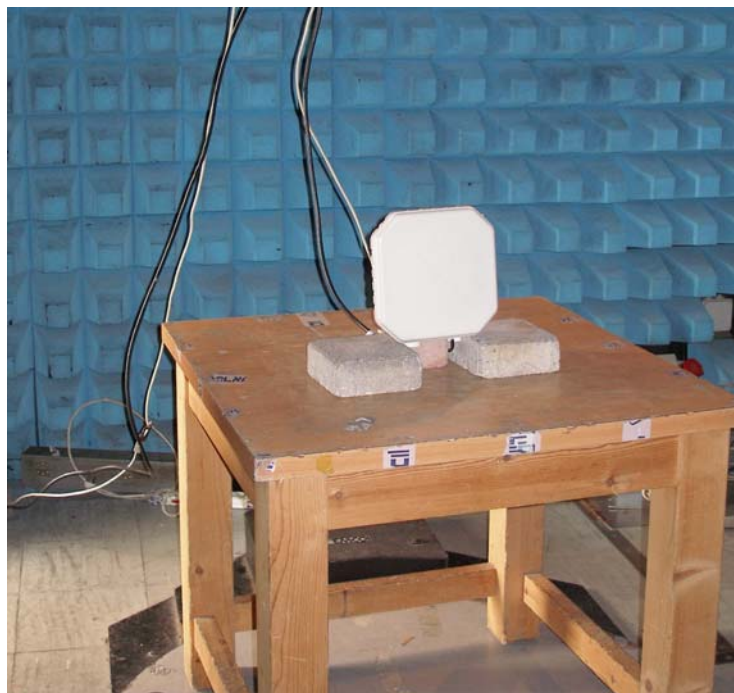

Photo #2. Test setup in anechoic chamber

Test report N: 9012332799/1

Page 43 of 49

Title: BreezeMax Extreme CPE System 5.x

Model: XTRM-SU-OD-1D-4.9-2-A

FCC ID: LKT-EXTR-CPE-50



Photo #3. Test setup in anechoic chamber.

Test report N: 9012332799/1
Title: BreezeMax Extreme CPE System 5.x
Model: XTRM-SU-OD-1D-4.9-2-A

Page 44 of 49

FCC ID: LKT-EXTR-CPE-50

9. APPENDIX B

Test equipment used

No	Description	Manufacturer information			Due Calibration date
		Name	Model No	Serial No	
1	Spectrum Analyzer 9 kHz - 40 GHz	HP	8565E	3835A01359	June 2011
2	Spectrum Analyzer 9 kHz - 26.5 GHz	Agilent	4407B	US40241729	June 2011
3	Attenuators set (2,3,10,20 dB) DC - 18 GHz	M/A-COM	2082	1650	Aug 2010
4	Power splitter DC – 18 GHz	Mini-Circuits	ZFRSC-183-S	SQ037601003	June 2011
5	Cable RF 1m	Huber-Suhner	Sucoflex 104	21324/4PE	October 2010
6	Double Ridged Guide Antenna 1 – 18 GHz	EMCO	3115	5802	Aug 2010
7	Broadband Horn antenna 15 – 40 GHz	Schwarzbeck Mess-Electronik	BBHA 9170	9170-341	Aug 2010
8	Antenna Biconilog 30 – 2000 MHz	Schaffner-Chase	CBL6112B	S/N 23181	Aug 2010
9	Spectrum analyzer 10 KHz-26.5 GHz	HP	E7405A	SII 4944	April 2011
10	EMI Receiver 9 kHz-6.5 GHz	HP	8546A+85460A	SII 4068	April 2011
11	Spectrum analyzer 20 Hz - 13.6 GHz	Agilent	MXA 9020A	MY48010682	June 2011
12	LISN 9 kHz – 30 MHz	FCC	LISN 250-32-4-16	SII5023	October 2010
13	Transient limiter 0.009-200 MHz	HP	11947A	3107105	October 2010
14	Cable RF 4m	Huber-Suhner	Sucoflex 104PE	21329/4PE	October 2010
15	Cable RF 0.5m	Huber-Suhner	Multiflex 141	520201	October 2010
16	Active Loop antenna 10 kHz – 30 MHz	EMCO	6502	SII 4874	October 2010

Test report N: 9012332799/1

Page 45 of 49

Title: BreezeMax Extreme CPE System 5.x

Model: XTRM-SU-OD-1D-4.9-2-A

FCC ID: LKT-EXTR-CPE-50

Cable Loss (10m cable + Mast)

Point	Frequency (MHz)	Cable Loss (dB)	Point	Frequency (MHz)	Cable Loss (dB)
1	30	0.53	21	1000	3.68
2	50	0.75	22	1100	3.82
3	100	1.08	23	1200	4.07
4	150	1.39	24	1300	4.24
5	200	1.61	25	1400	4.43
6	250	1.752	26	1500	4.6
7	300	2.00	27	1600	4.7
8	350	2.15	28	1700	4.85
9	400	2.26	29	1800	4.98
10	450	2.383	30	1900	5.19
11	500	2.52	31	2000	5.34
12	550	2.606	32	2100	5.51
13	600	2.75	33	2200	5.69
14	650	2.856	34	2300	5.89
15	700	3.06	35	2400	6.07
16	750	3.201	36	2500	6.22
17	800	3.27	37	2600	6.28
18	850	3.38	38	2700	6.41
19	900	3.46	39	2800	6.53
20	950	3.55	40	2900	6.84



Test report N: 9012332799/1

Page 46 of 49

Title: BreezeMax Extreme CPE System 5.x

Model: XTRM-SU-OD-1D-4.9-2-A

FCC ID: LKT-EXTR-CPE-50

Biconilog Antenna, Model Number: CBL-6112D, S/N: 23181.

No.	f / MHz)	AF / dB/m	f / MHz)	AF / dB/m	f / MHz)	AF / dB/m	f / MHz)	AF / dB/m
1	30	17.90	170	9.40	530	17.70	1040	22.20
2	32	16.70	175	9.00	540	18.25	1060	22.50
3	34	15.55	180	8.50	550	18.60	1080	22.50
4	36	14.35	185	8.45	560	14.45	1100	22.40
5	38	13.30	190	8.60	570	18.40	1120	22.60
6	40	12.20	195	8.85	580	18.50	1140	22.45
7	42	11.05	200	8.95	590	18.60	1160	22.50
8	44	9.95	205	8.80	600	18.60	1180	22.40
9	46	8.90	210	8.50	610	18.80	1200	22.80
10	48	8.05	215	8.20	620	18.99	1220	22.95
11	50	7.30	220	8.50	630	19.05	1240	23.10
12	52	6.80	225	9.00	640	19.23	1260	23.40
13	54	6.45	230	9.65	650	19.10	1280	23.35
14	56	6.00	235	10.30	660	19.13	1300	23.62
15	58	5.70	240	11.00	670	19.04	1320	23.64
16	60	5.45	245	11.60	680	19.00	1340	23.86
17	62	5.30	250	12.00	690	19.17	1360	23.95
18	64	5.20	255	12.45	700	19.28	1380	23.90
19	66	5.30	260	12.85	710	19.25	1400	24.45
20	68	5.30	265	12.50	720	19.45	1420	24.74
21	70	5.35	270	12.45	730	19.75	1440	24.93
22	72	5.50	275	12.40	740	19.95	1460	25.03
23	74	5.80	280	12.55	750	20.07	1480	25.45
24	76	6.00	285	12.65	760	19.85	1500	25.30
25	78	6.60	290	12.75	770	19.80	1520	25.25
26	80	6.70	295	12.95	780	19.85	1540	25.36
27	82	7.15	300	13.00	790	19.95	1560	25.58
28	84	7.60	310	13.35	800	20.05	1580	25.50
29	86	8.10	320	13.75	810	20.10	1600	25.65
30	88	8.50	330	13.85	820	20.35	1620	25.60
31	90	8.90	340	14.10	830	20.40	1640	25.70
32	92	9.20	350	14.50	840	20.35	1660	25.83
33	94	9.75	360	14.70	850	20.46	1680	25.97
34	96	9.95	370	14.90	860	20.39	1700	26.10
35	98	10.20	380	15.10	870	20.29	1720	26.25
36	100	10.50	390	15.45	880	20.24	1740	26.04
37	105	11.25	400	16.00	890	20.35	1760	26.14
38	110	11.70	410	16.40	900	20.55	1780	26.20
39	115	11.70	420	16.70	910	20.45	1800	26.40
40	120	11.80	430	16.35	920	20.60	1820	26.64
41	125	11.80	440	16.30	930	20.60	1840	26.86
42	130	11.70	450	16.30	940	20.66	1860	27.12
43	135	11.35	460	16.70	950	20.88	1880	27.00
44	140	10.95	470	17.05	960	21.11	1900	27.25
45	145	10.35	480	17.20	970	20.93	1920	27.36
46	150	10.05	490	17.30	980	21.03	1940	27.68
47	155	9.70	500	17.40	990	21.05	1960	27.10
48	160	9.70	510	17.50	1000	21.10	1980	27.06
49	165	9.45	520	17.60	1020	21.40	2000	27.25



Test report N: 9012332799/1

Page 47 of 49

Title: BreezeMax Extreme CPE System 5.x

Model: XTRM-SU-OD-1D-4.9-2-A

FCC ID: LKT-EXTR-CPE-50

Antenna Factor**Double Ridged Guide Antenna mfr EMCO model 3115 1m calibration**

Point	Frequency (MHz)	Antenna Factor (dB/m)
1	1000	23.9
2	2000	28.3
3	3000	31.0
4	4000	33.1
5	4500	32.5
6	5000	32.4
7	6000	53.7
8	6500	35.6
9	7000	36.4
10	7500	36.9
11	8000	37.0
12	8500	38.0
13	9000	38.6
14	9500	38.4
15	10000	38.4
16	10500	38.4
17	11000	38.9
18	11500	39.6
19	12000	39.4
20	12500	39.2
21	13000	40.3
22	13500	41.0
23	14000	41.2
24	14500	41.3
25	15000	40.0
26	15500	38.0
27	16000	38.1
28	16500	40.3
29	17000	42.2
30	17500	44.6
31	18000	46.2

Cable Loss**Type: Sucoflex 104PE; Ser.No.21329/4PE; 4 m length**

Point	Frequency (GHz)	Cable Loss (dB)
1	0.0-1.0	1.7
2	1.0- 3.5	3.2
3	3.5- 5.5	4.0
4	5.5 - 7.5	4.7
5	7.5 - 9.5	5.3
6	9.5 - 10.5	5.6
7	10.5 - 12.5	6.2
8	12.5 - 14.5	6.8
9	14.5 - 16.5	7.5
10	16.5 - 18.0	8.1



Test report N: 9012332799/1

Page 48 of 49

Title: BreezeMax Extreme CPE System 5.x

Model: XTRM-SU-OD-1D-4.9-2-A

FCC ID: LKT-EXTR-CPE-50

Antenna Factor
Broadband Horn Antenna model BBHA 9170 1m calibration

Point	Frequency (GHz)	Antenna Factor (dB/m)
1	15.0	38.5
2	16.0	37.7
3	17.0	38.1
4	18.0	37.9
5	19.0	38.0
6	20.0	38.0
7	21.0	37.9
8	22.0	38.2
9	23.0	39.6
10	24.0	39.6
11	25.0	39.3
12	26.0	39.5
13	27.0	39.6
14	28.0	39.6
15	30.0	40.1
16	32.0	41.2
17	34.0	41.5
18	35.0	41.9
19	36.0	42.2
20	38.0	43.8
21	40.0	43.2



Test report N: 9012332799/1

Page 49 of 49

Title: BreezeMax Extreme CPE System 5.x

Model: XTRM-SU-OD-1D-4.9-2-A

FCC ID: LKT-EXTR-CPE-50

10. APPENDIX C

Abbreviations and acronyms

The following abbreviations and acronyms are applicable to this test report:

AC	alternating current
cm	centimeter
dB	decibel
dBm	decibel referred to one milliwatt
dB(μ V)	decibel referred to one microvolt
dB(μ V/m)	decibel referred to one microvolt per meter
EMC	electromagnetic compatibility
EUT	equipment under test
GHz	gigahertz
H	height
Hz	hertz
kHz	kilohertz
L	length
LNA	low noise amplifier
m	meter
Mbps	megabit per second
MHz	megahertz
NA	not applicable
OFDM	Orthogonal Frequency Division Multiple Access
PRBS	pseudo random binary sequence
QP	quasi-peak
RF	radio frequency
RE	radiated emission
SA	spectrum analyzer
rms	root mean square
W	width

Specification references

47 CFR part 90: 2009	Private land mobile radio services.
ANSI C63.2: 1996	American National Standard for Instrumentation Electromagnetic Noise and Field Strength, 10 kHz to 40 GHz Specifications.
ANSI C63.4: 2003	American National Standard for Method of Measurements of Radio-Noise Emissions from Low-Voltage Electrical and Electronic Equipment in the Range of 9 kHz to 40 GHz