

EMISSIONS TEST REPORT FOR A LOW POWER TRANSMITTER

I. GENERAL INFORMATION

Requirement: Federal Communications Commissions

Test Requirements: 15.205, 15.207, 15.209, 15.247

Applicant: Alvarion Ltd.

Product ID: **FCC ID: LKT-ASU-900**

II. DESCRIPTION OF EQUIPMENT UNDER TEST (EUT)

The EUT is a DTS transmitter operating under section 15.247 of FCC Rules. The EUT is a hybrid system, using a frequency hopping function along with digital modulation of the RF carrier.

RF Specifications

RF Frequency Band	904 – 926 MHz
RF Channels	Programmable in 1 MHz steps
Modulation Type	GFSK DTS/FHSS hybrid
Transmitter Output Power	24 dBm typical, variable in approx. 1 dB steps
Antennas	11 dBi flat panel antenna 14.6 dBi sector antenna 6 dBi and 9 dBi omni antennas

Product configurations:

CX-2.4-900 base station

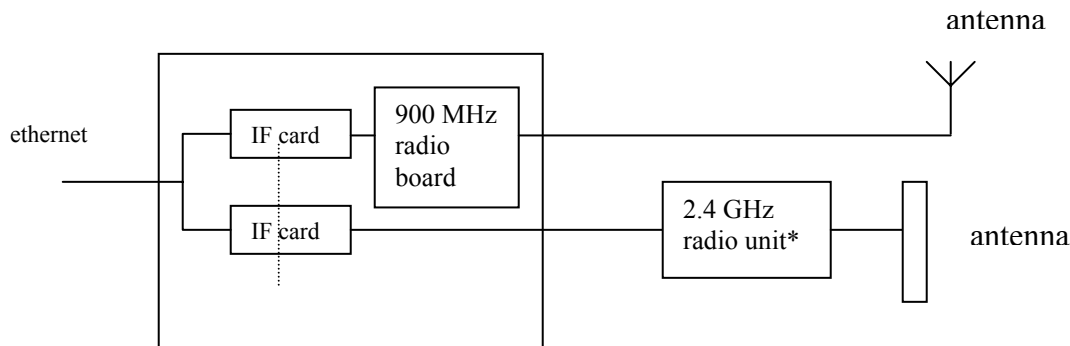

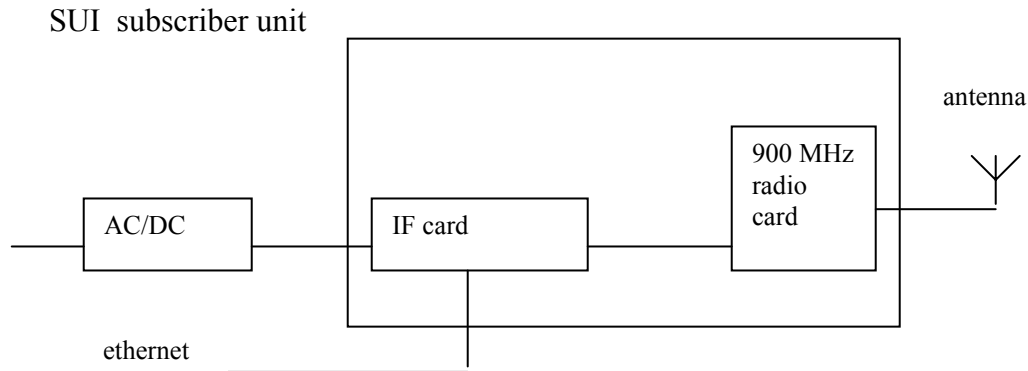
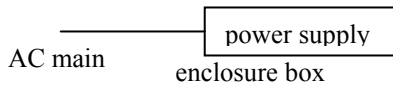

The base station can be mounted indoors or outdoors. Antenna cable lengths are usually longer for indoor mounted units.

The 2.4 GHz external radio is a previously certified Alvarion product, FCC ID: LKT-IF-24.

The IF card delivers a 440 MHz modulated signal and DC power to the radio units. The IF card is identical to the ones used in other Alvarion 2.4 GHz and 5.7 GHz products.

The interface between the Outdoor and Indoor Units is identical to all of BreezeACCESS systems. The subscriber IF circuitry is the same as the base station IF circuitry.

Antennas are outdoor fixed mounted.

III. TEST LOCATION

Frequency hopping timing characteristics were measured at Alvarion's laboratory in Carlsbad, CA. All other FCC tests were performed at

Compliance Certification Services
571F Monterey Road
Morgan Hill, CA 95037

Alvarion Ltd.
FCC ID: LKT-ASU-900

902-928 MHz DTS Systems

T.N. Cokenias
EMC Consultant/Agent for Alvarion Ltd.

31 May 2003

TEST PROCEDURES

The EUT can be configured for use with various antennas and antenna cable lengths. FCC Rules limit power spectral density to 8 dBm in a 3 kHz bandwidth. RF output power is adjusted to meet psd limits while maximizing RF output power. Maximum allowed output power settings are as follow:

MaxPower at Antenna connector dBm	Power at Cable end, dBm	Cable
24.56	23.6	10ft LMR400
24.56	20.8	100ft LMR 400

Radiated Emissions

Test Requirement: 15.109, 15.205, 15.209, 15.247

Measurement equipment used:

Agilent 4440A Spectrum Analyzer, 9 kHz-26.5 GHz
Chase Biconolog antenna
EMCO 3115 Horn antenna, 1-18 GHZ
ARA Horn antenna, 12 – 26.5 GHz
Miteq pre-amplifier, 1 – 26.5 GHz
IFI High pass filter, fp = 1800 MHz

Test Procedures, 1- 26 GHz:

1. The EUT was placed on a wooden table resting on a turntable on the open air test site. The search antenna was placed 3m from the EUT. The EUT antenna was mounted vertically as per normal installation.
2. The turntable was slowly rotated to locate the direction of maximum emission at each emission falling in the restricted bands of 15.205.
3. Radiated emissions were investigated for a LOW channel, a MID channel, and HIGH channel. Emissions were investigated to the 10th harmonic.
4. Once maximum direction was determined, the search antenna was raised and lowered in both vertical and horizontal polarizations. The maximum readings so obtained are recorded in the data listed below.

Radiated Test Set-up, 1-40 GHz

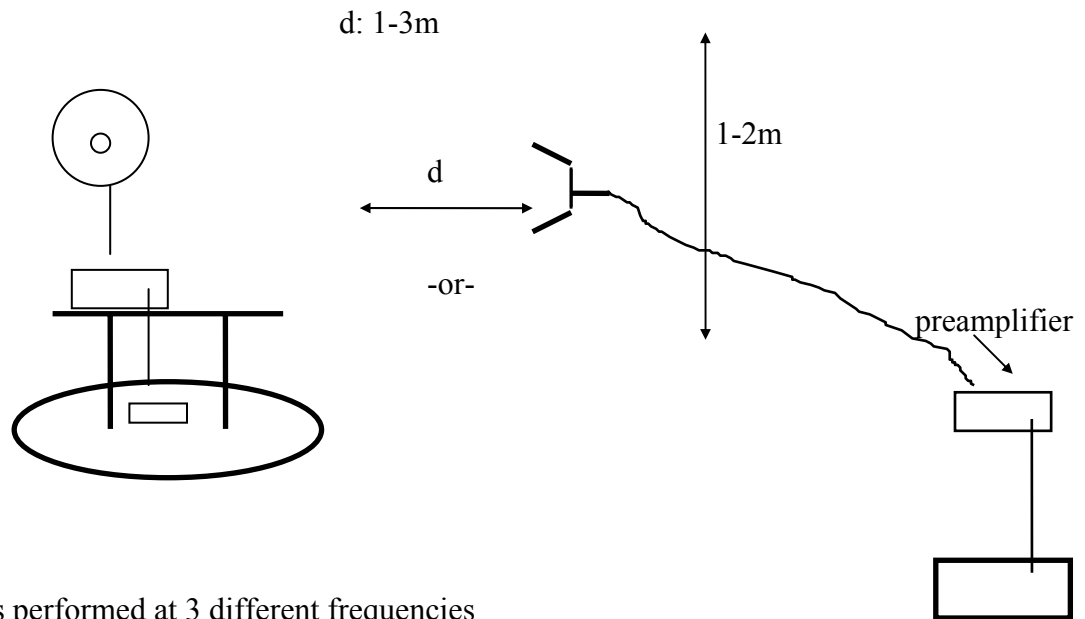

Figure 2

Testing was performed at 3 different frequencies

Channel	Frequency, MHz
Low	904
Mid	915
High	926

Radiated emissions were performed at each frequency for 3 different transmitter antennas.

Antennas tested:

Antenna Type	Gain	Antenna Manufacturer	Model Number
omni	9 dBi	Mobilemark	MFB91579-2400
sector	14.6 dBi	Pacific Wireless	PAWDC24

Test Results: Worst case results are presented. Refer to separate Excel spread sheet files.

Radiated Test Set-up, 30 - 1000 MHz

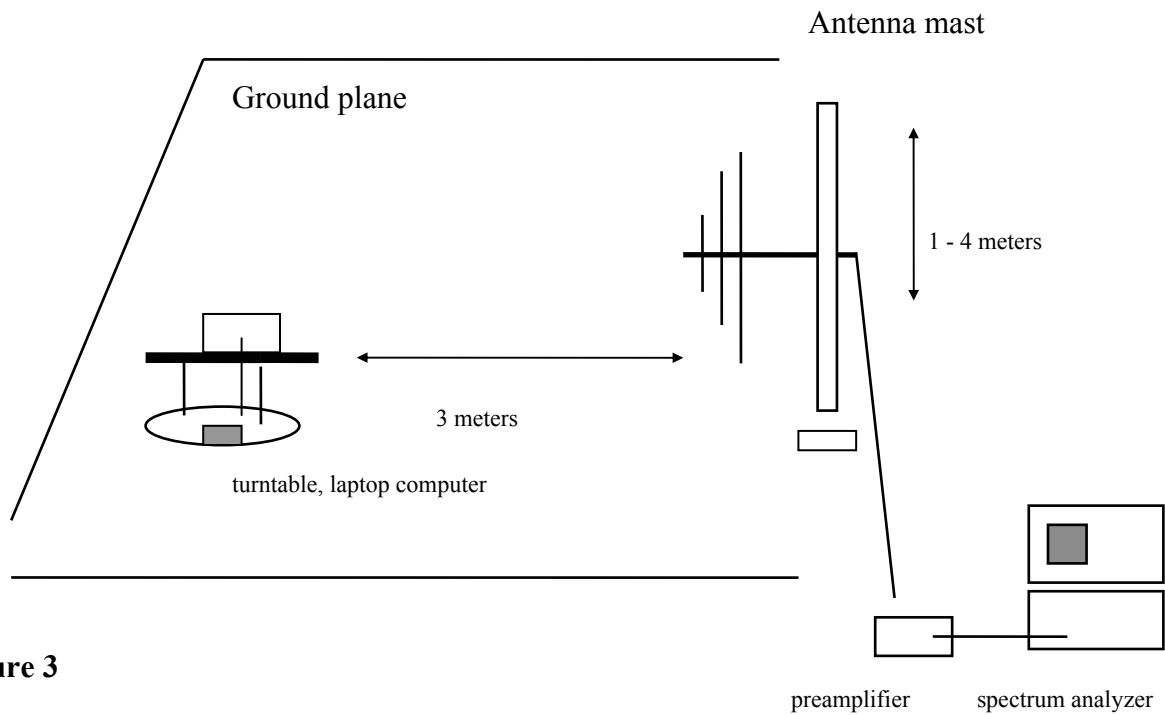

Figure 3

Test Procedures, 30 -1000 MHz

The EUT was set to RECEIVE/TRANSMIT mode. Radiation emissions from the digital portion of the EUT were measured according to the dictates of ANSI C63.4.

Alvarion Ltd.
FCC ID: LKT-ASU-900

902-928 MHz DTS Systems

Test Results

Refer to separate attachment.

AC Line Conducted Emissions
Test Requirement: 15.107, 15.207

Measurement Equipment Used:

Rohde & Schwarz EMI Receiver ESHS-20
Fischer Custom Communication LISN, FCC-LISN-50/250-25-2

Test Procedure

1. The EUT was placed on a wooden table 40 cm from a vertical ground plane and approximately 80 cm above the horizontal ground plane on the floor. The EUT was set to transmit in normally.
2. Line conducted data was recorded for both NEUTRAL and HOT lines.

Test Results

PASS. Refer to data sheets in separate attachment.

Minimum 6 dB Bandwidth

Test Requirement: 15.247(a)2

Measurement Equipment Used:

Agilent 4440A Spectrum Analyzer
20 dB attenuator

Test Procedures

The EUT was configured on a test bench. The EUT was set for continuous operation . Frequency was set to LOW channel. While the transmitter broadcast a steady stream of digital data, the analyzer MAX HOLD function was used to capture the envelope of the transmission occupied bandwidth.

The test was repeated at MID channel and at HIGH channel.

Test Results: Refer to attached spectrum analyzer charts. Data is presented for both product packaging configurations. Data taken with RES BW of 100 kHz shows minimum 6 dB BW of 1.25 MHz. Minimum requirement: 500 kHz

Channel	Frequency, MHz
Low	904
Mid	915
High	926

15.247(a)2: Minimum 6 dB Bandwidth:

LOW Channel

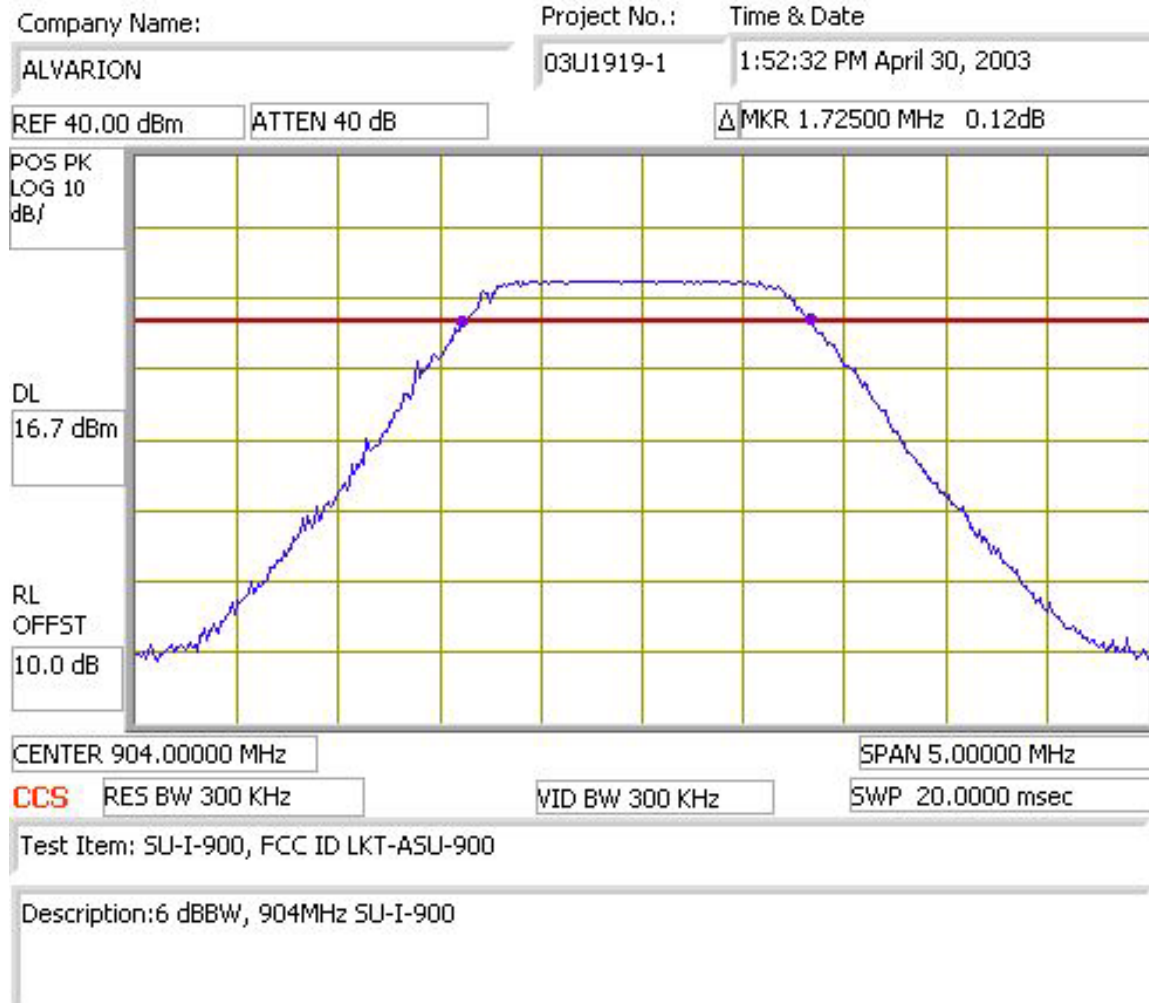

Minimum 6 dB BW

MID Channel

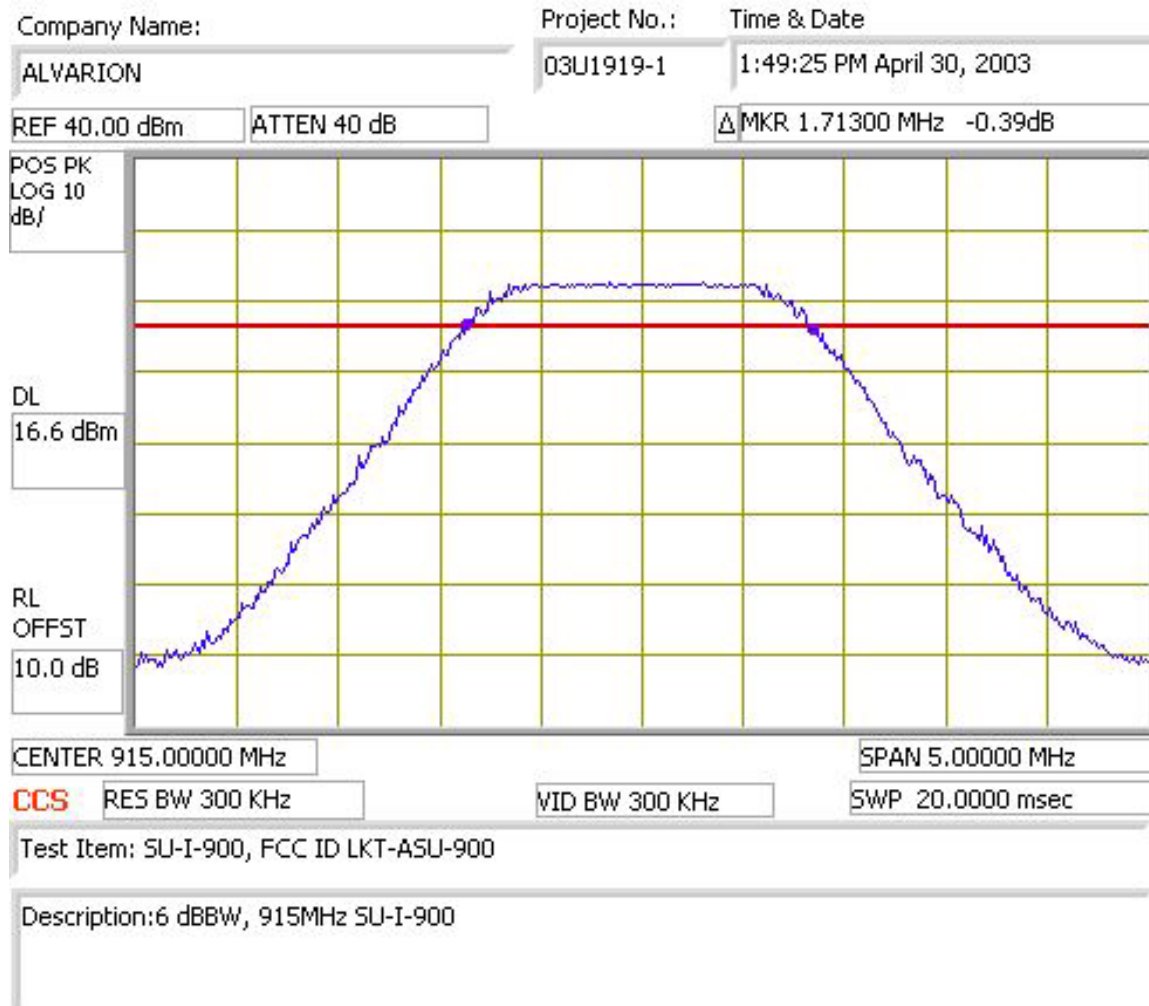

Minimum 6 dB BW

HIGH Channel

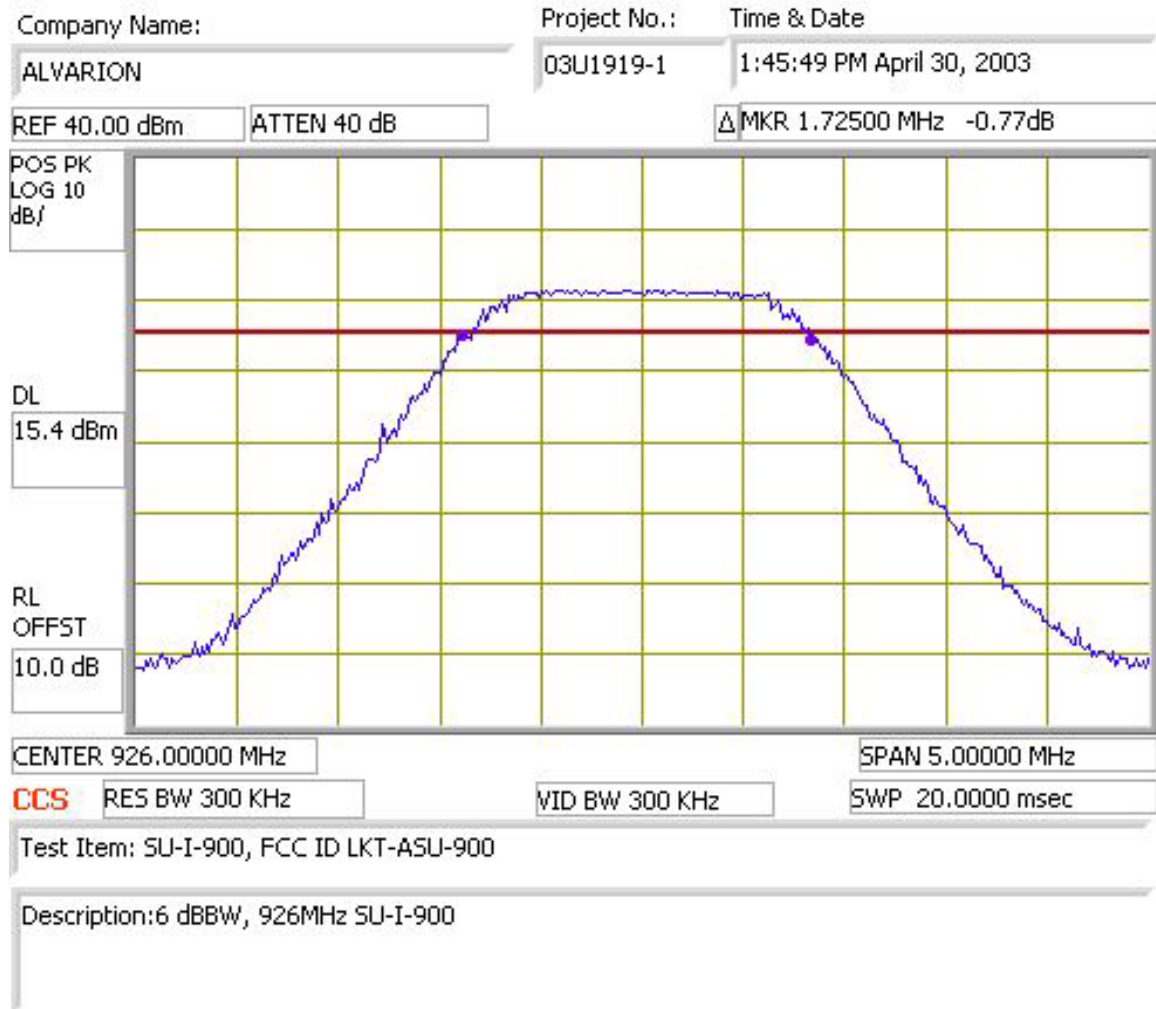

RF Power Output

Test Requirement: 15.247(b)

Measurement Equipment Used:

Agilent E4416A power meter
Agilent E9327A peak RF power sensor
20 dB attenuator

Test Procedures

1. The EUT was configured on a test bench. The power meter was zeroed and calibrated.
The control software was activated and power was set to produce highest output level.
2. The 20 dB attenuator was connected to the antenna port of the EUT. The power meter head was connected to the other end of the attenuator. Peak power was read directly off the meter, accounting for the 20 dB attenuator.
3. The process in (1) and (2) was repeated for MID channel and HIGH channel.

Test Results

Power level readings converted to dBm are shown below. Refer also to spectrum analyzer graphs. Reference level offset corrects for external attenuation and cable loss.

MaxPower at Antenna connector dBm	Power at Cable end, dBm	Cable
24.56	23.6	10ft LMR400
24.56	20.7	100ft LMR 400

F(MHz)	Pout, antenna port	P out, 10ft cable
904	24.24	23.6
915	24.56	23.6
926	23.9	22.97

Maximum output power output variation within 0.5 dBm of target 24 dBm output.

Spurious Emissions, Conducted
Test Requirement: 15.247(c)

Measurement Equipment Used:

HP 8563 Spectrum Analyzer (Pointred Technologies)
20 dB attenuator
3ft length coaxial cable (2 dB loss)

Test Procedure

1. The EUT was configured on a test bench. The cable was connected between the EUT antenna port and the spectrum analyzer input port.

Spectrum analyzer RES BW was set to 100 kHz. While the transmitter broadcast a steady stream of digital data, the analyzer MAX HOLD function was used to capture the envelope of the transmission.

Readings were taken out to 10fo.

2. The process in (1) was repeated for MID channel and HIGH channel.

Test Results

Refer to attached data sheets. Data shows out of band emissions are suppressed well below the -20 dBc minimum required by the Rules.

Channel	Frequency, MHz
LOW	904
MID	915
HIGH	926

15.247(c): Spurious Emissions, Conducted, -20 dBc

LOW Channel

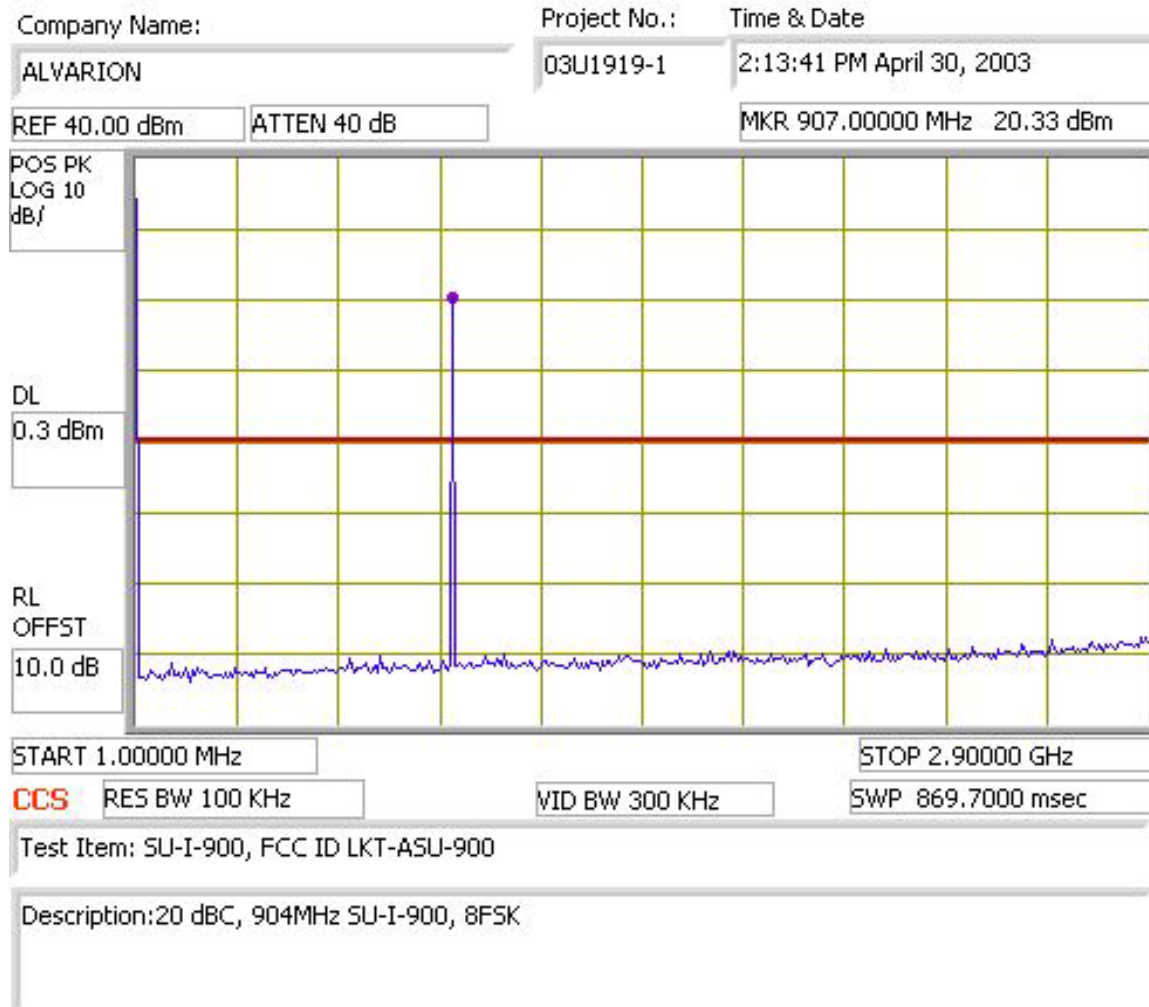

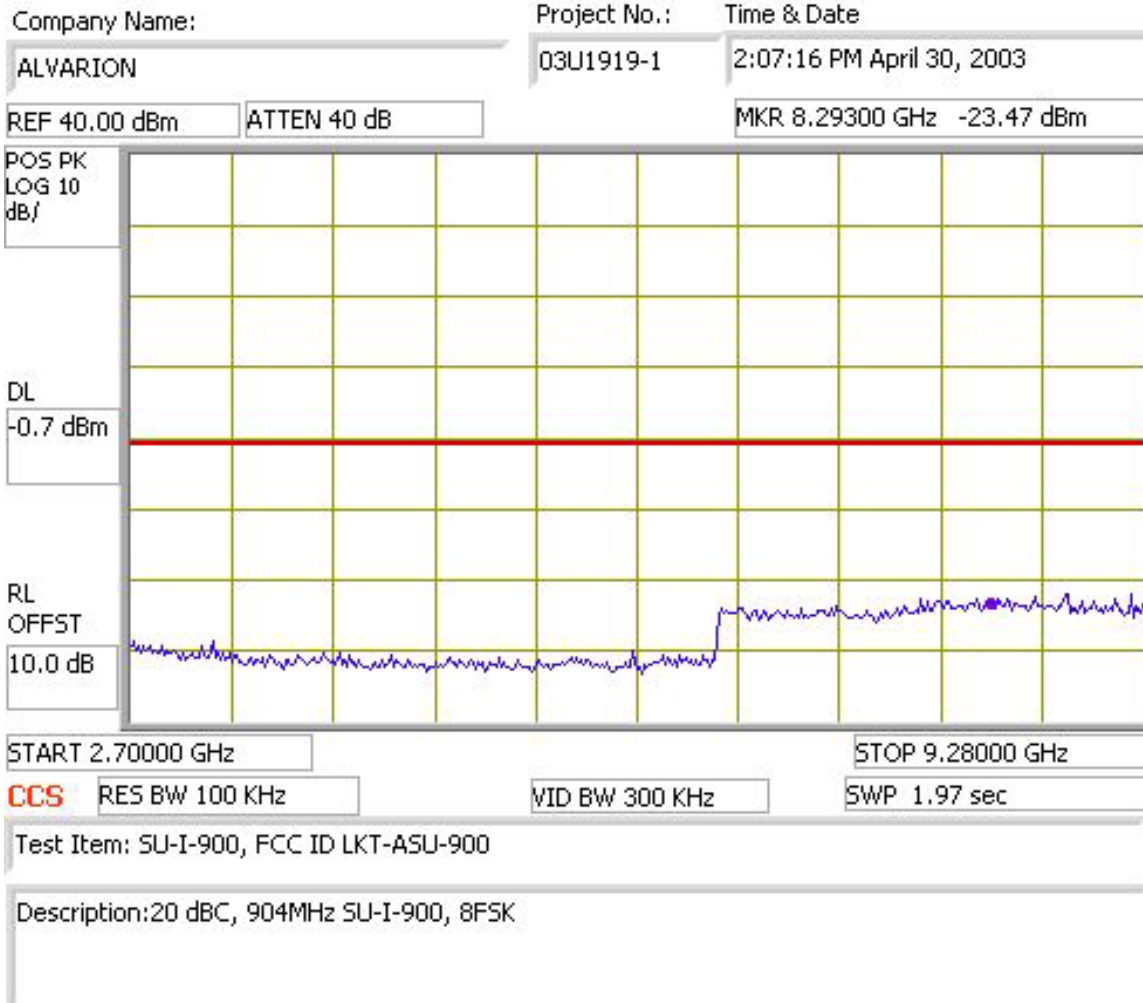

15.247(c): Spurious Emissions, Conducted, -20 dBc

MID Channel

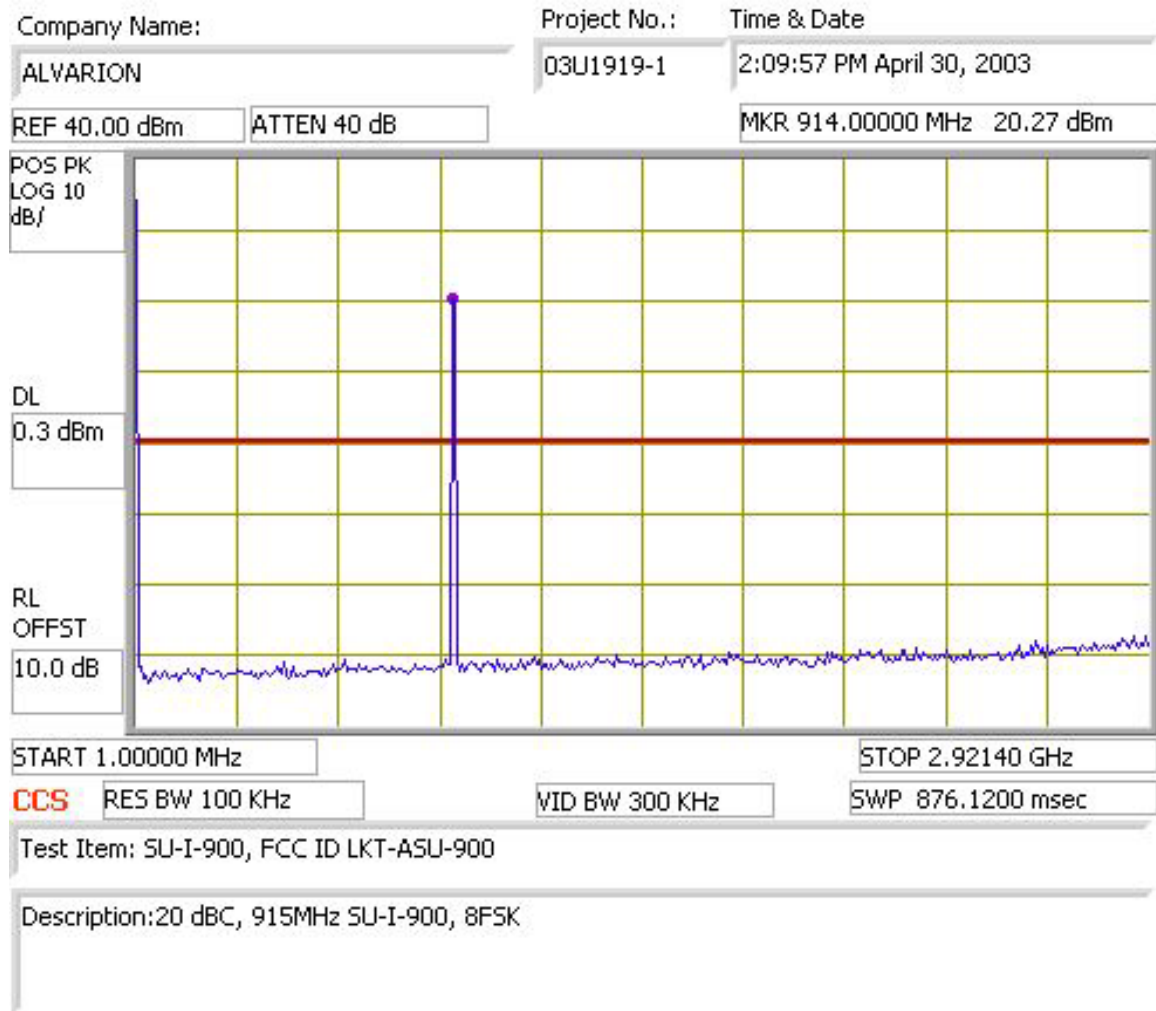

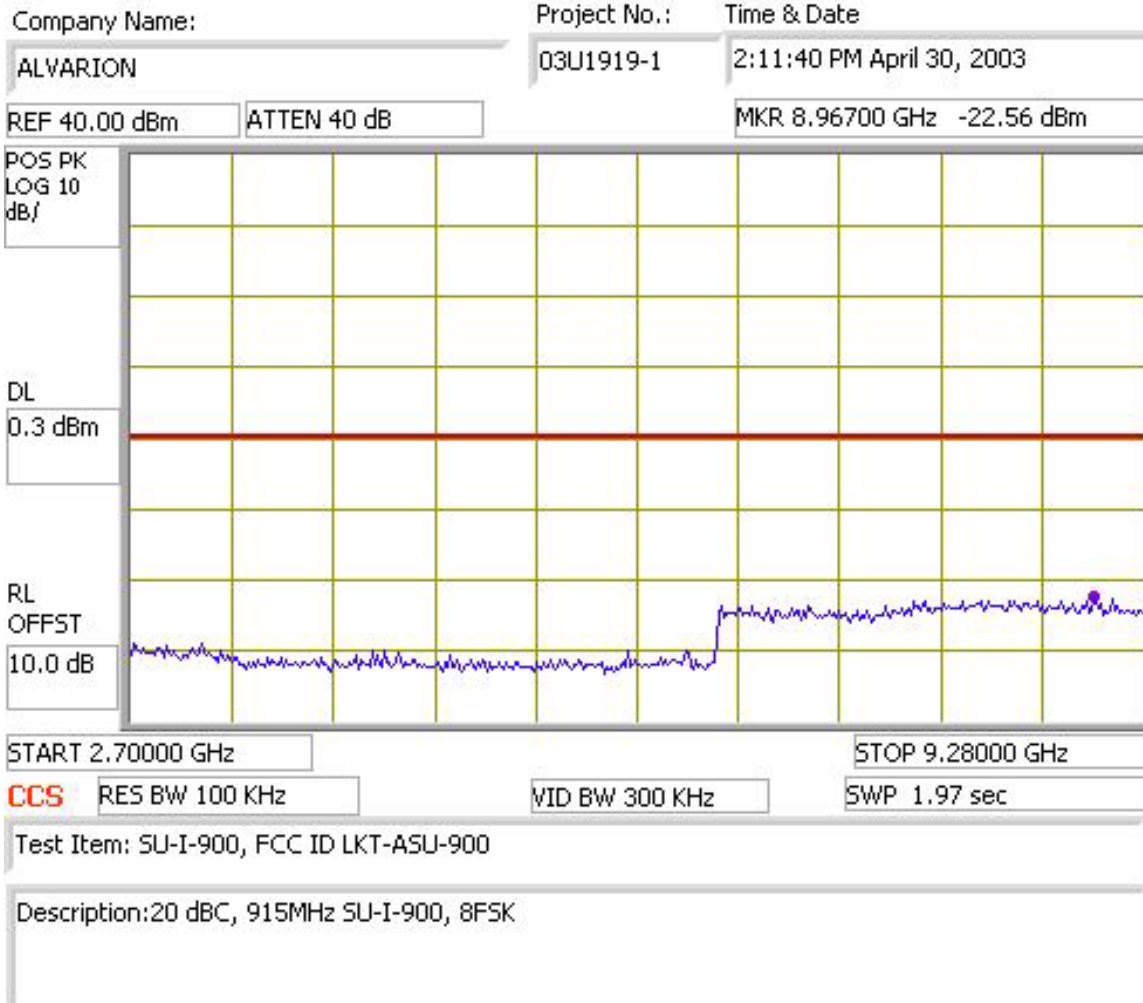

**15.247(c): Spurious Emissions, Conducted, -20 dBc
High Channel**

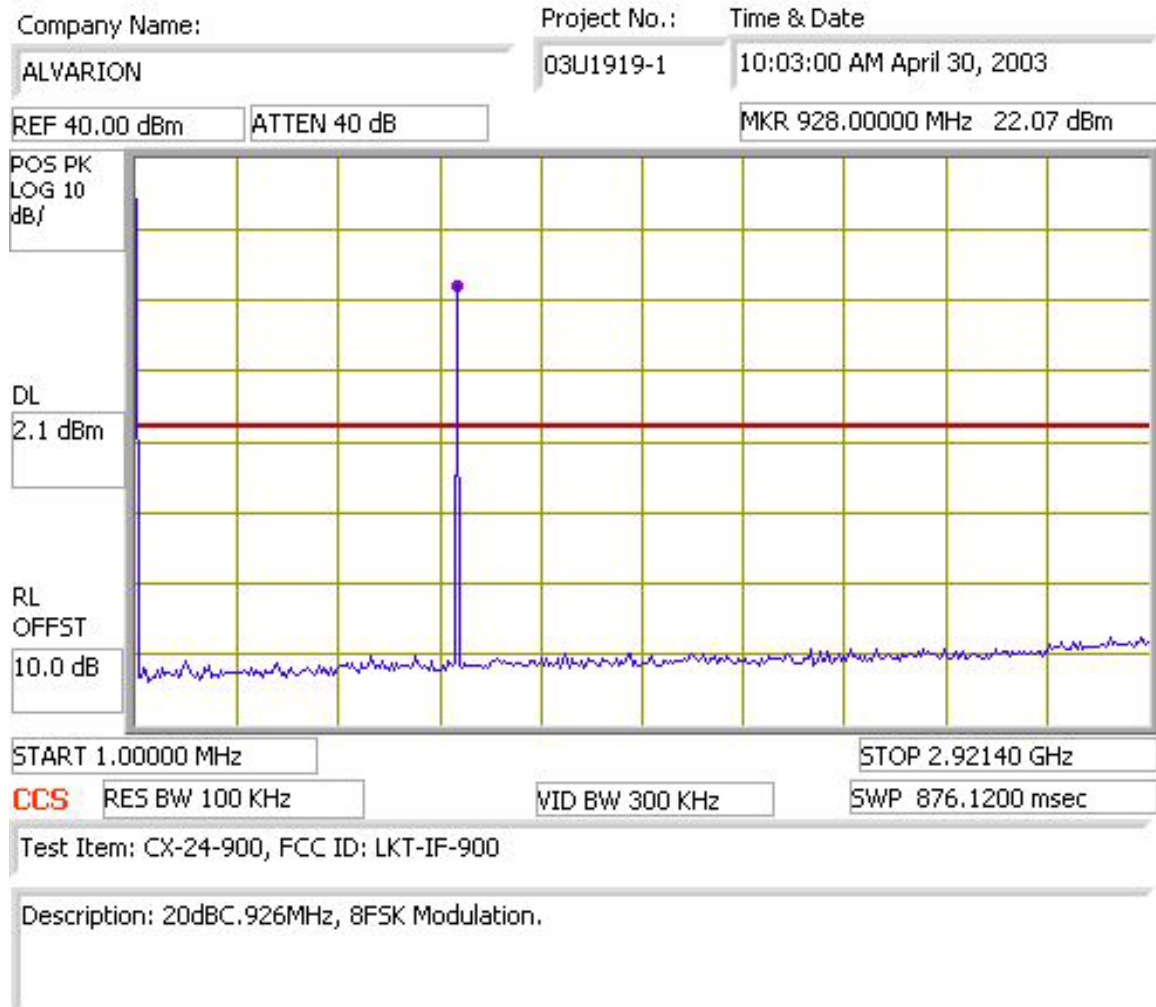

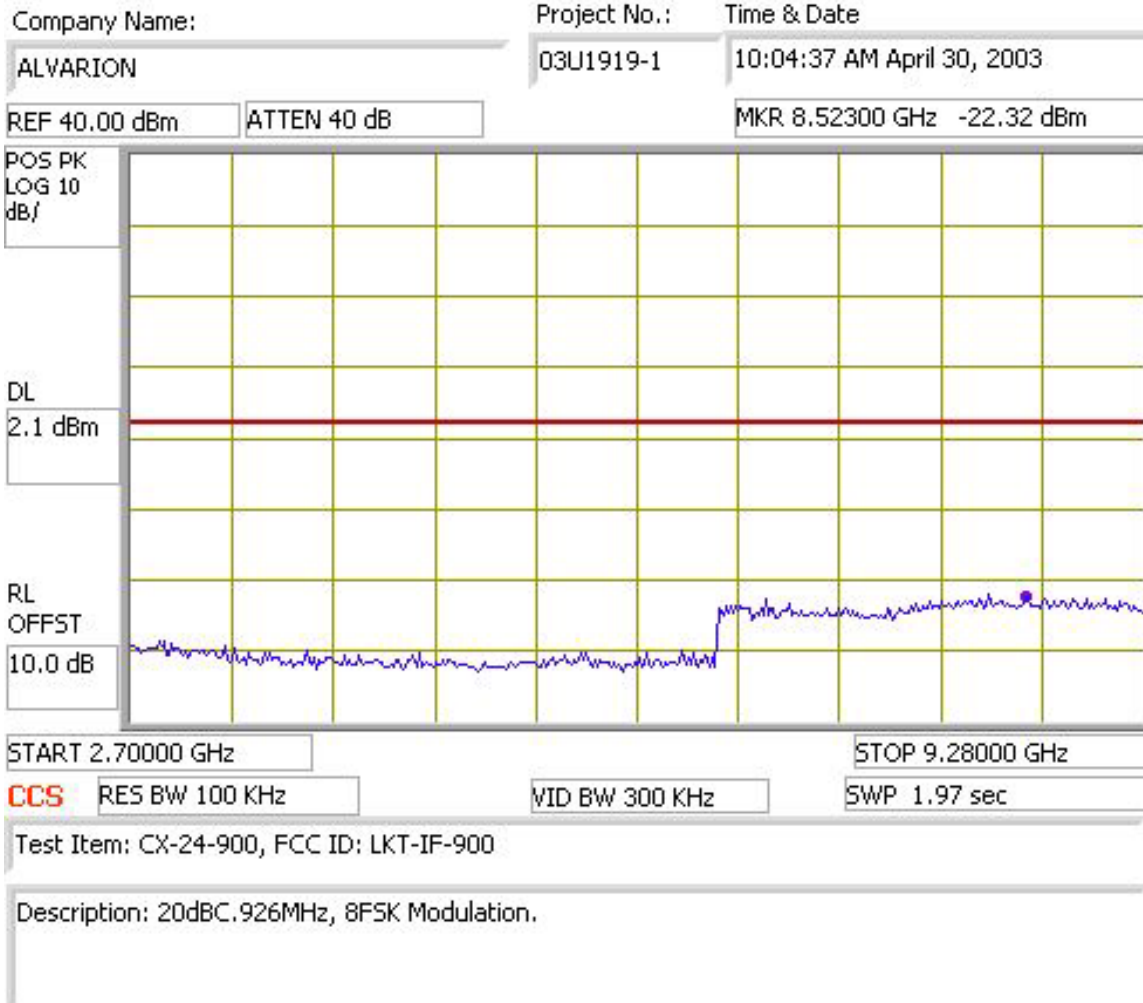

Power Spectral Density

Test Requirement: 15.247(d)

Measurement Equipment Used:

Agilent 4440A Spectrum Analyzer
Antenna cable specified for EUT

Test Procedure

For the LOW channel, the emission peak was set to the center of the display. The SPAN was set to 300 kHz, the RES BW and VID BW were set to 3 kHz, and SWEEP TIME was set to 100 seconds. The maximum trace was recorded and compared to the 8 dBm limit.

The test was repeated for MID and HIGH channel.

PSD readings were taken with the specified antenna cable connected between the EUT and the spectrum analyzer. Tests were performed minimum cable length specified for this radio.

Test Results

Maximum measured PSD was approximately 7.9 dBm. Refer to attached spectrum analyzer charts.

Channel	Frequency, MHz
LOW	904
MID	915
HIGH	926

15.247(d): Power Spectral Density: 24.56 dBm into 10 ft LMR400

LOW Channel

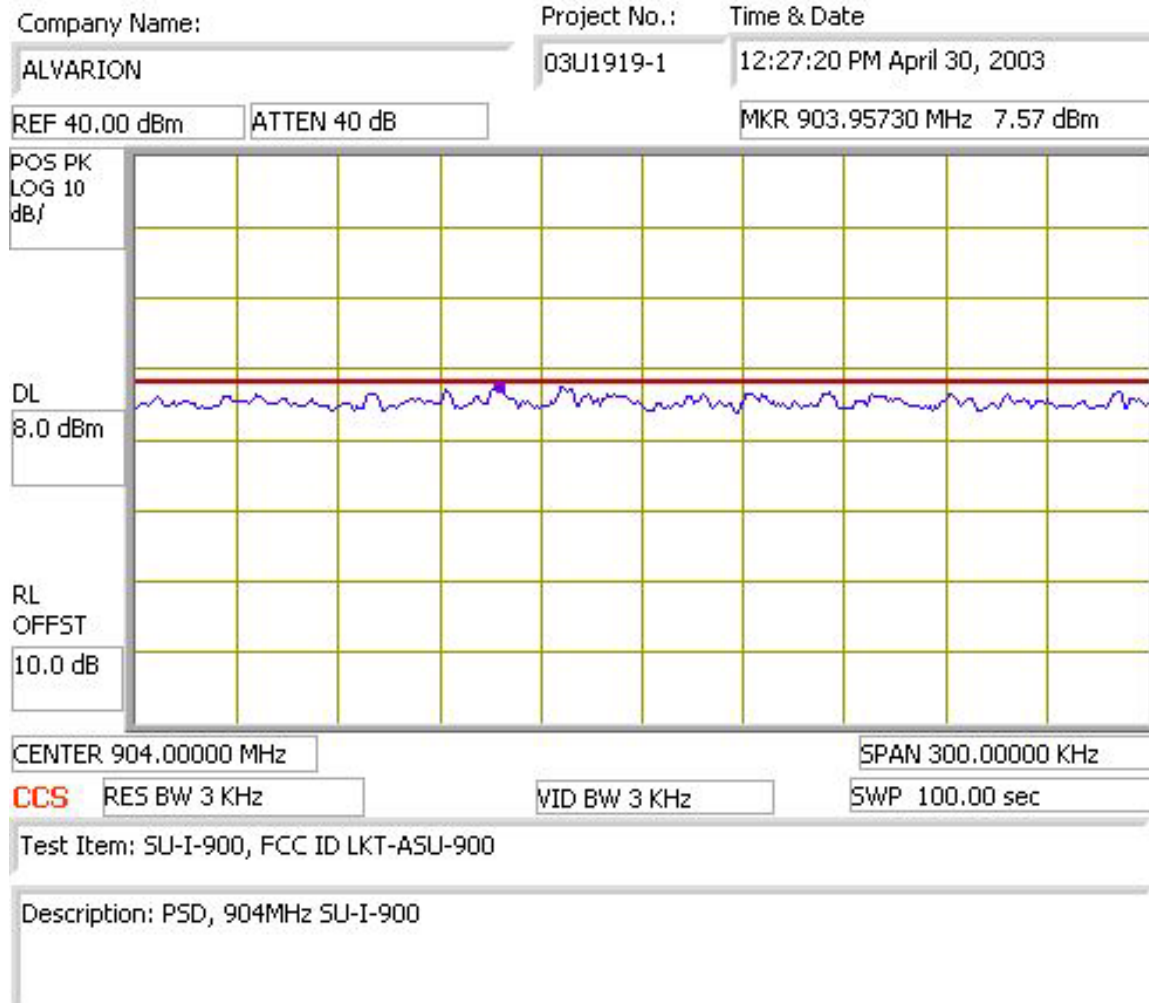

15.247(d): Power Spectral Density: 24.56 dBm into 10 ft LMR400

MID Channel

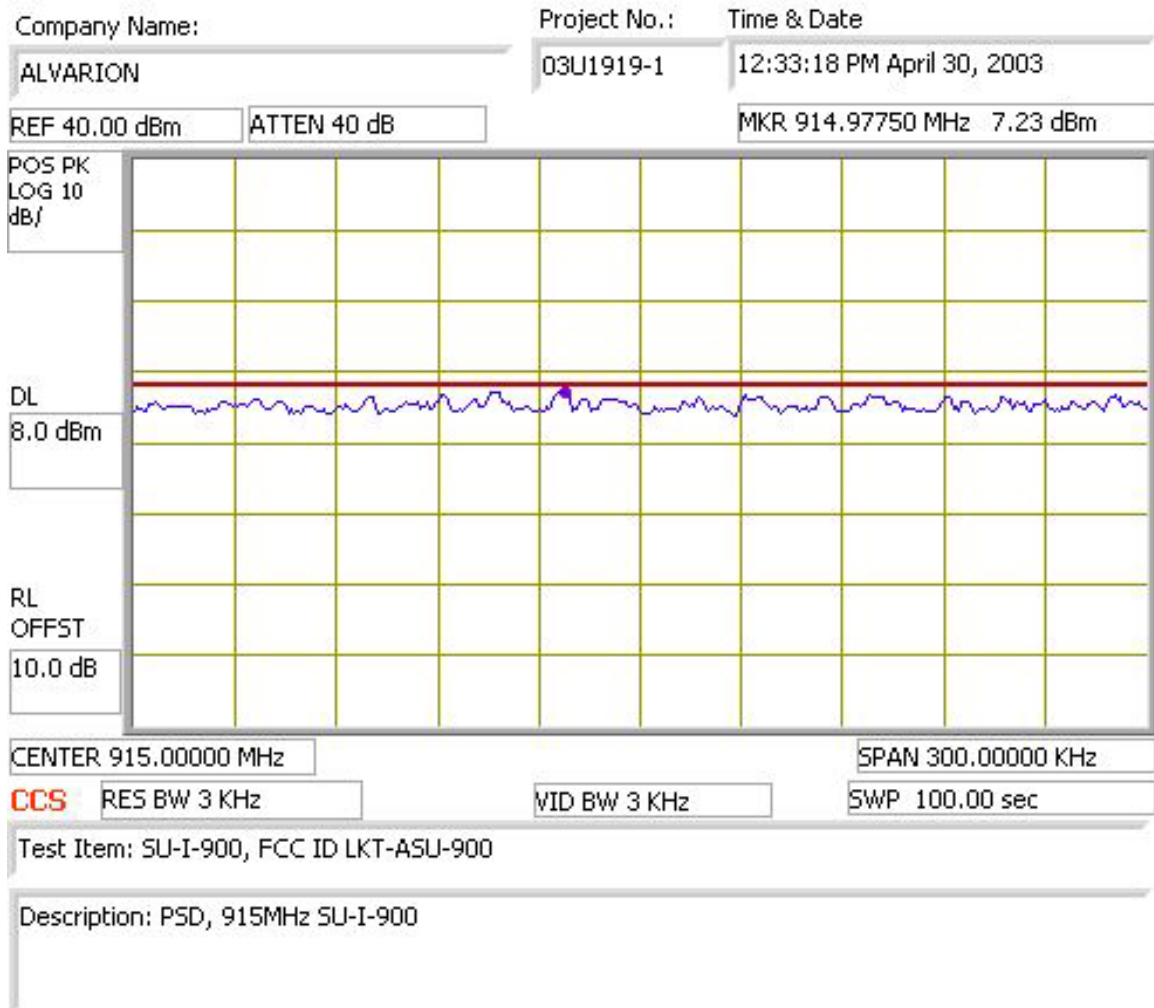

15.247(d): Power Spectral Density: 24.56 dBm into 10 ft LMR400

HIGH Channel

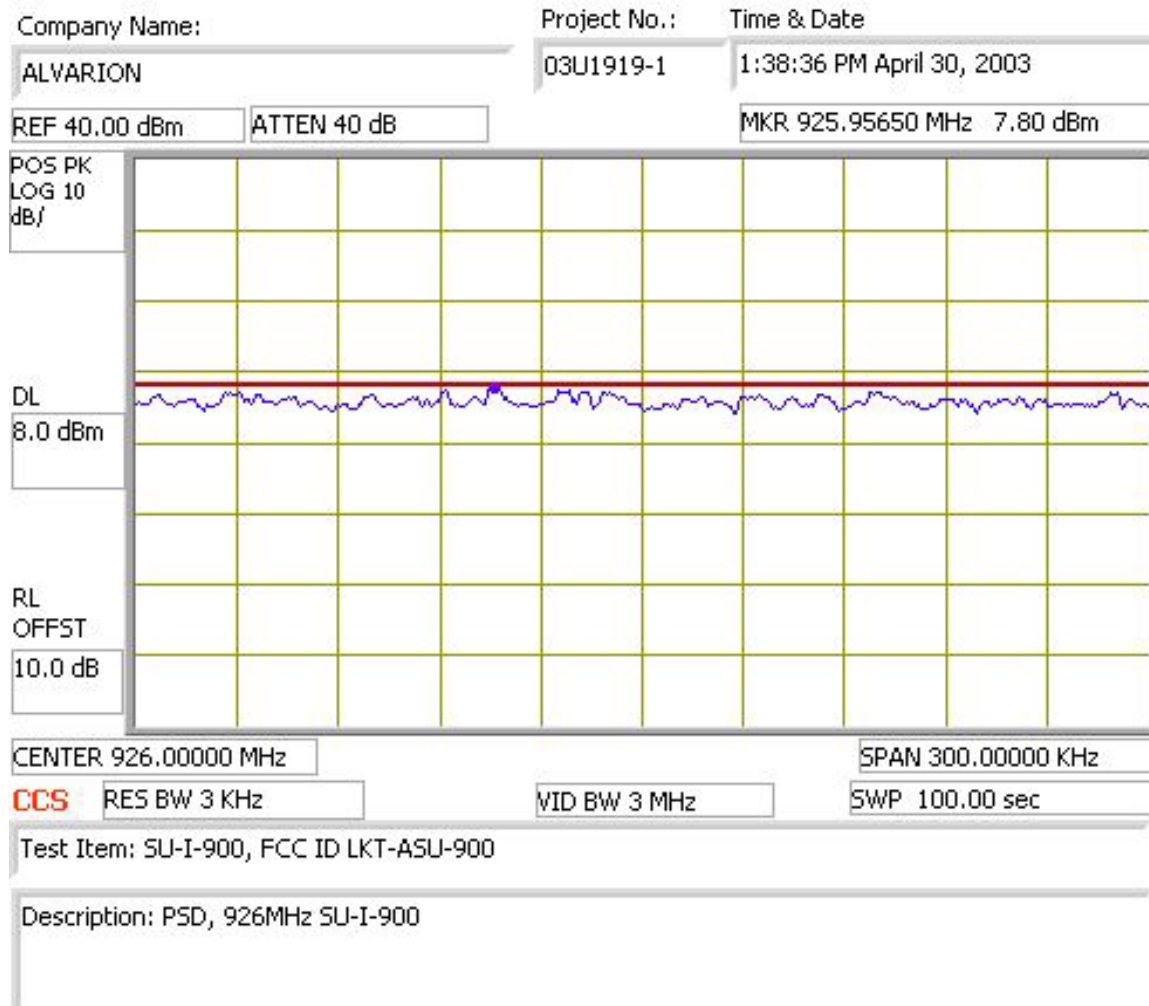

Average Time of Channel Occupancy
Test Requirement: 15.247

Measurement Equipment Used:

IFR Model 2398 Spectrum Analyzer
6' length cable with loop pickup

Test Procedure

1. The EUT was configured on a test bench. The EUT's hopping function was activated.
2. Spectrum analyzer center frequency was set to 915 MHz, one of the EUT hopping frequency. SWEEP TIME was adjusted until an accurate hop duration time could be displayed. VIDEO TRIGGER was used to capture the signal. The loop was placed over the EUT antenna.
3. Spectrum analyzer center frequency was set to 915 MHz, span 0 Hz, sweep time 20 sec, the loop was placed around the antenna of the EUT.
4. While the transmitter broadcast a steady stream of digital data, spectrum analyzer captured the ON time of the 905 MHz transmission during 20 seconds.
5. Step 3 was repeated 5 times. The channel occupancy time was determined as being the average of the 5 data runs.

Test Results

Plot 1 is the plot of hopping from 904 - 926 (inclusive) step 2 MHz, total 12 channels.

Plot 2 shows the 4.8s sweep on 926MHz, 0 span. ($12 \text{ hops} * 0.4 = 4.8\text{s}$)

Plot 3 is the same as above but on 904 MHz.

Plot 4 is the same as above but on 916 MHz. (2 - 4 shows the same number of hops and duration of hop per 4.8s period for 3 representative hop channels)

Plot 5 shows the duration of the transmission on the hop as 126mS each. As shown in 2 - 4, the average time occupied is 126mS per hop 4.8s period.

Plot 6 shows hopping on 6 channels, 904 - 914 MHz.

Plot 7 shows the same average time occupied for the 2.4s period ($6 \text{ hops} * 0.4\text{s} = 2.4\text{s}$) is the same as for 12 hop

Plot1

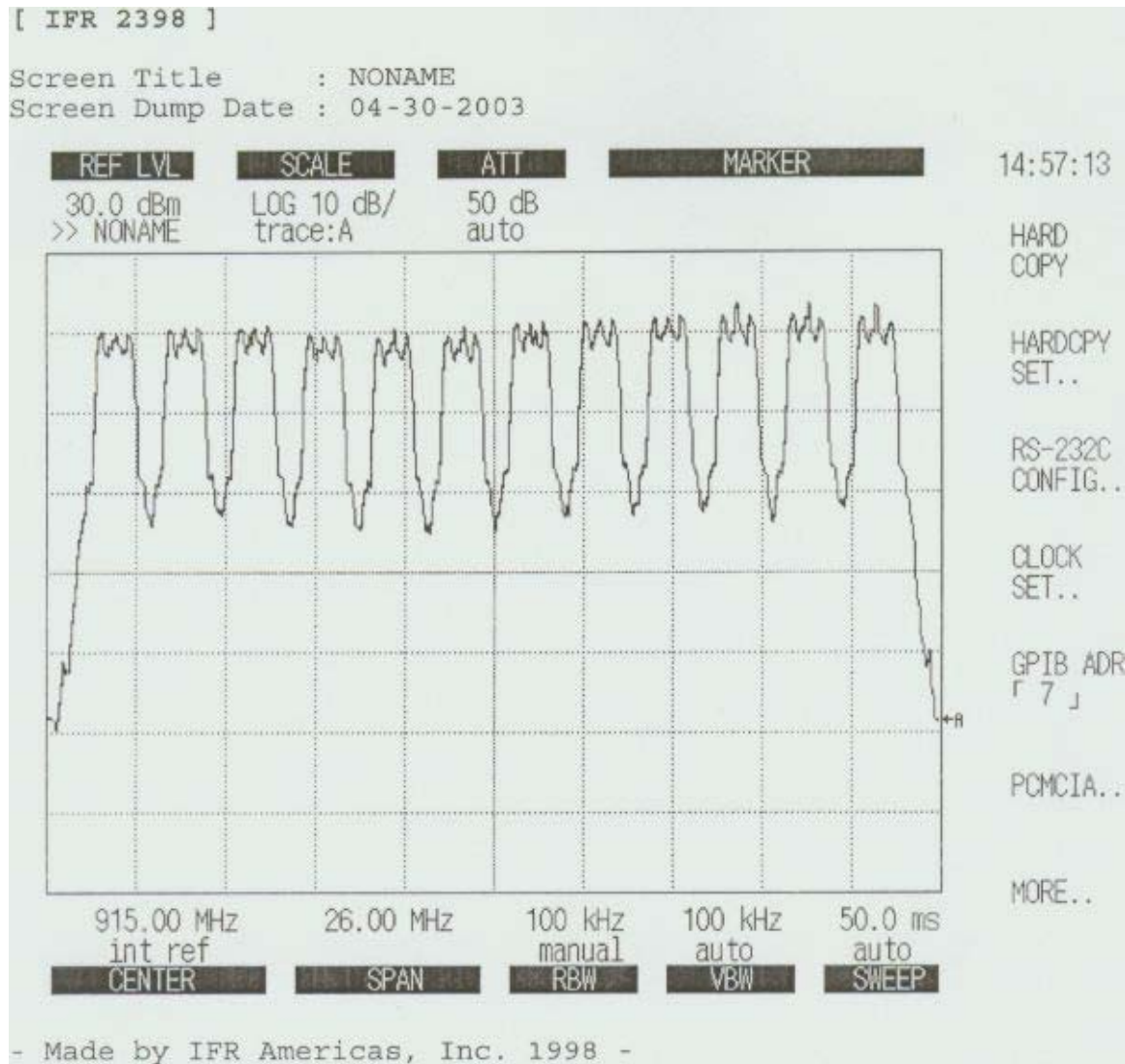

Plot 2

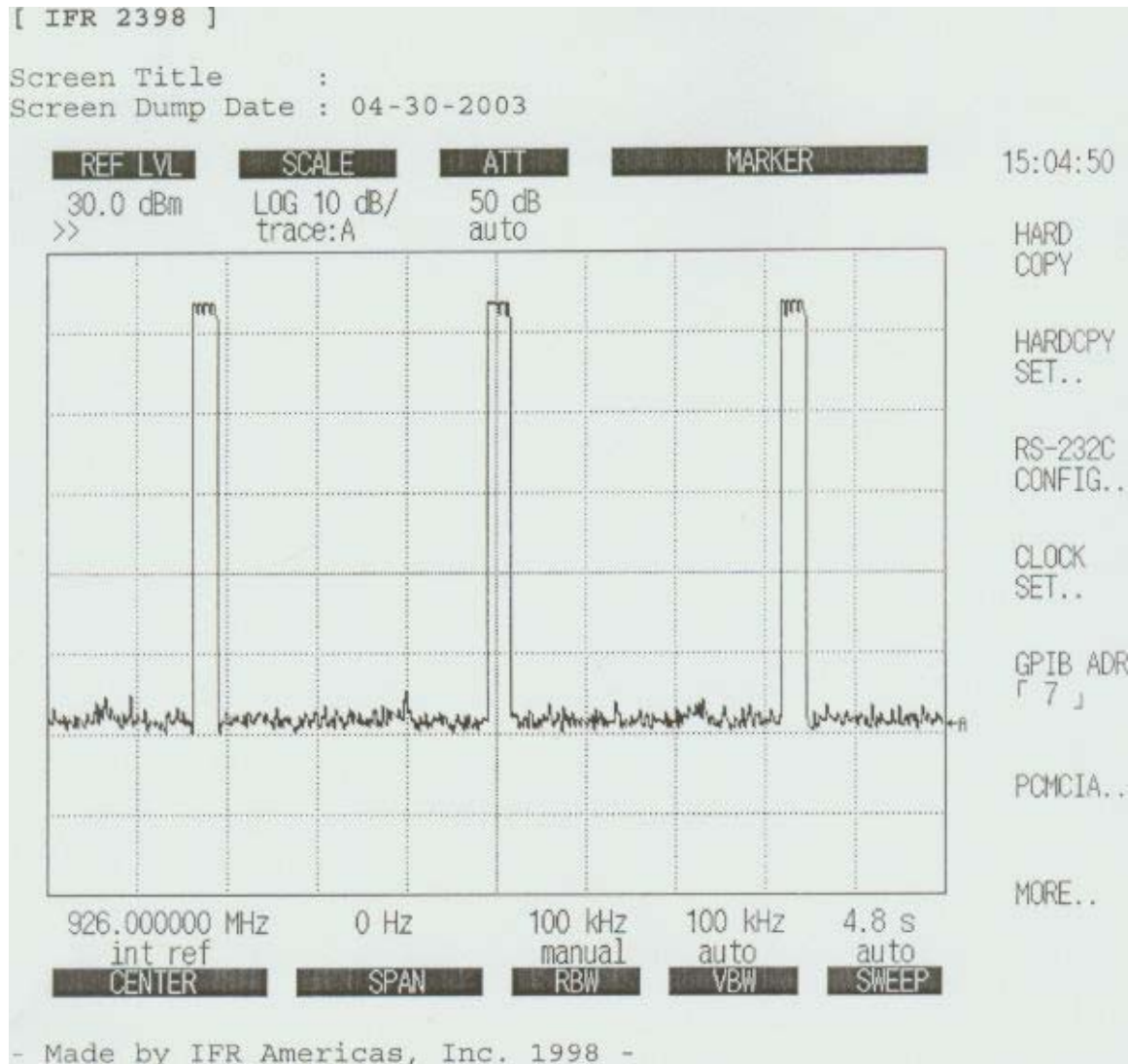

Plot 3

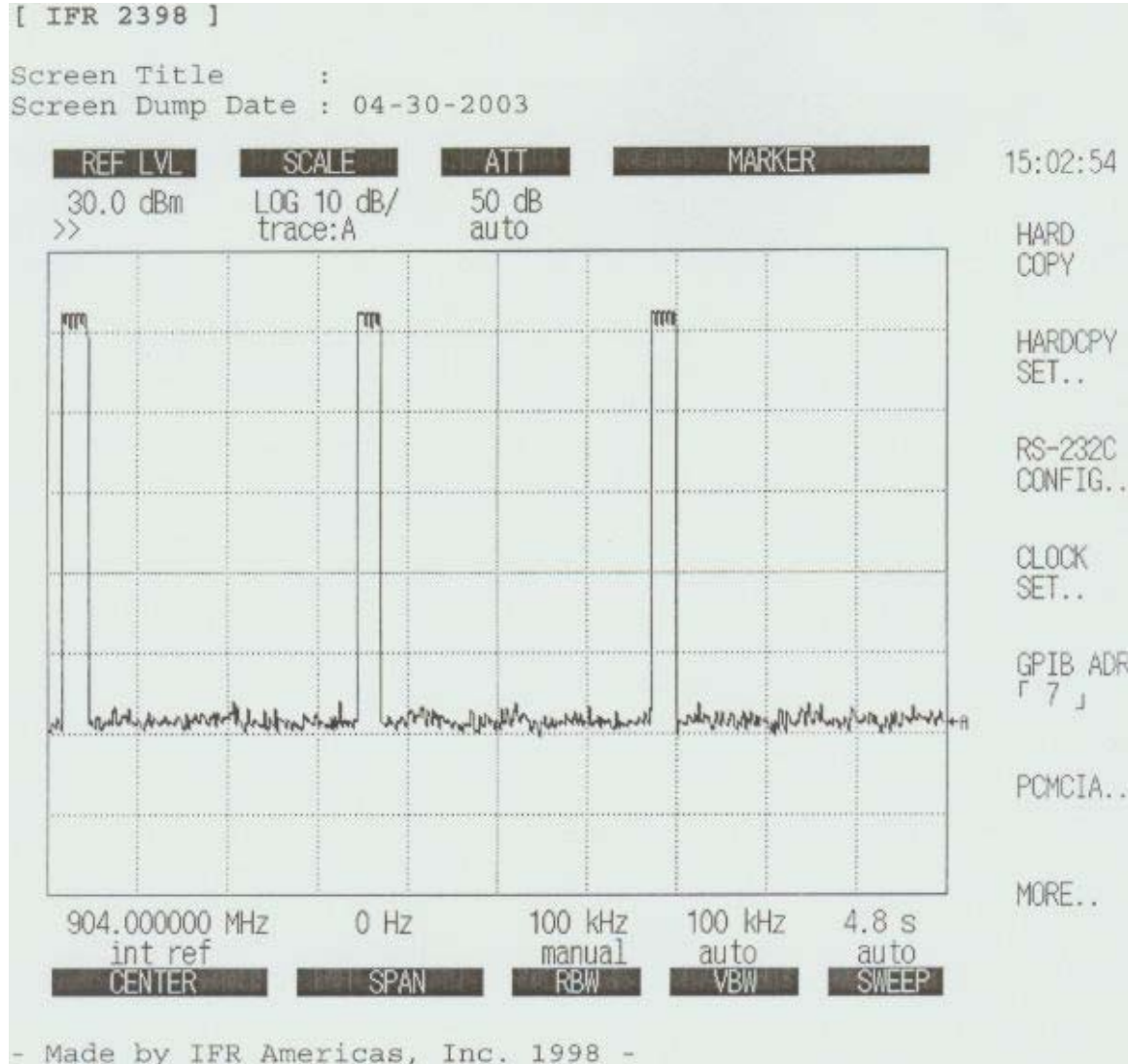

Plot 4

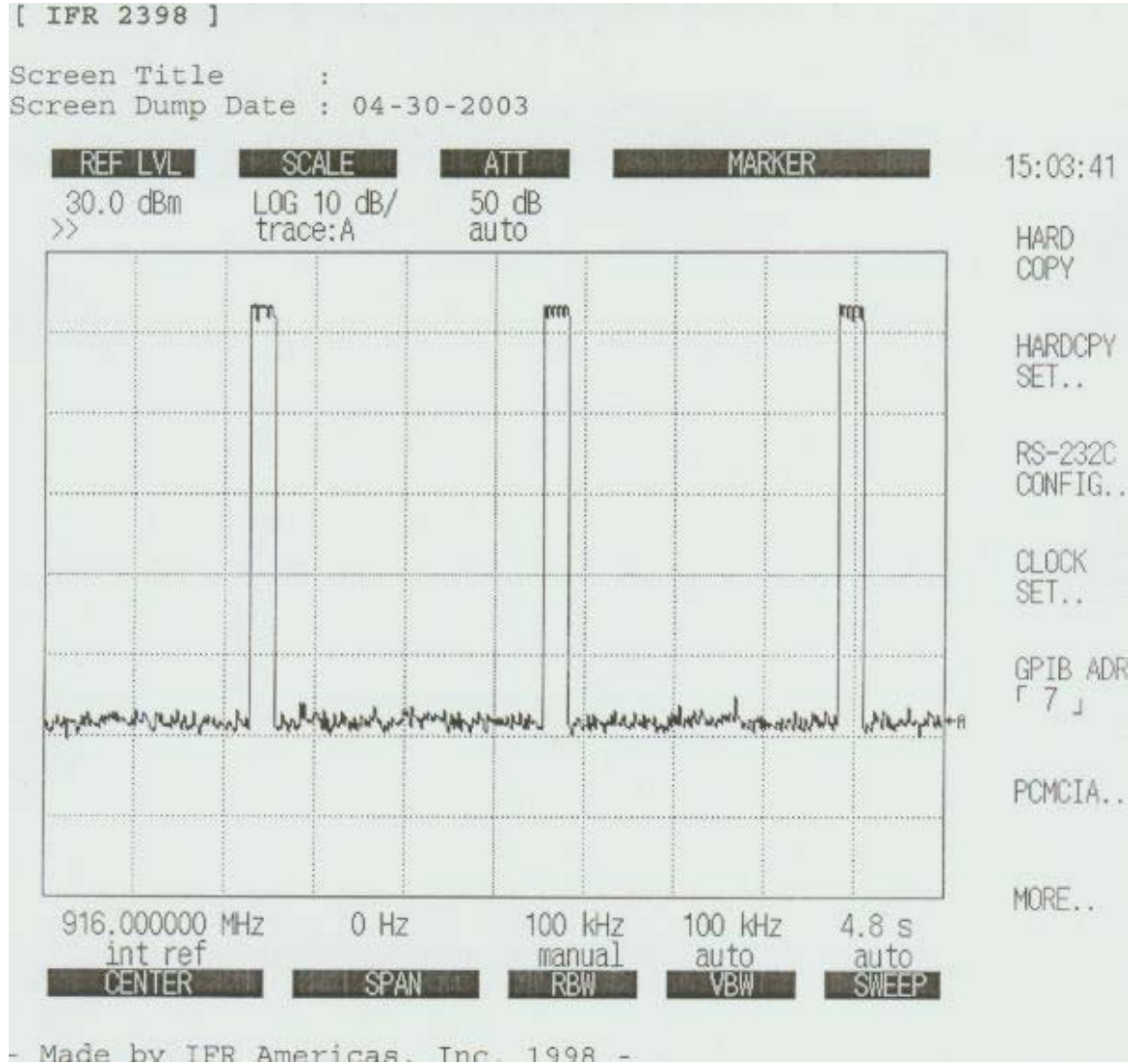

Plot 5

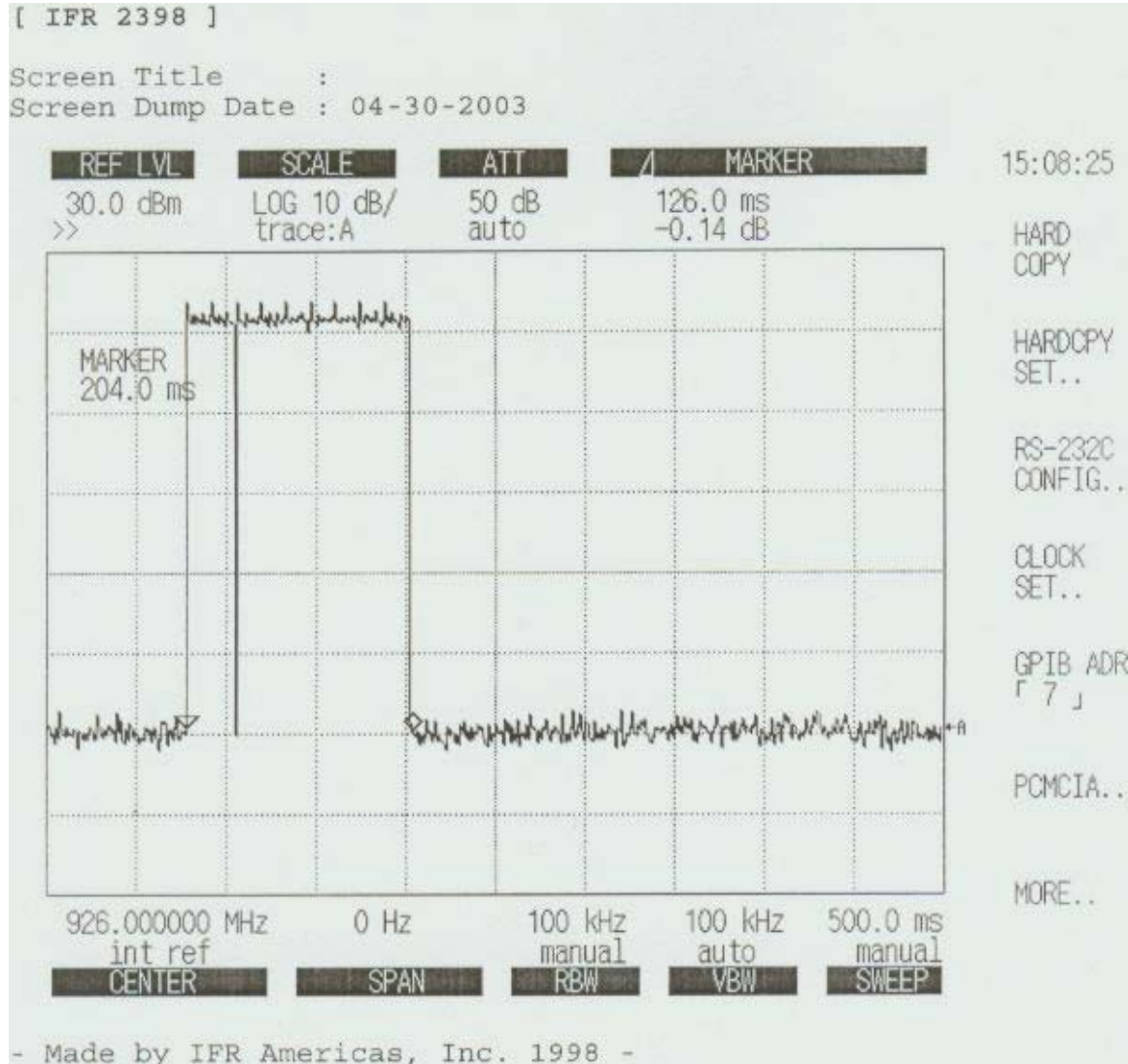

Plot 6

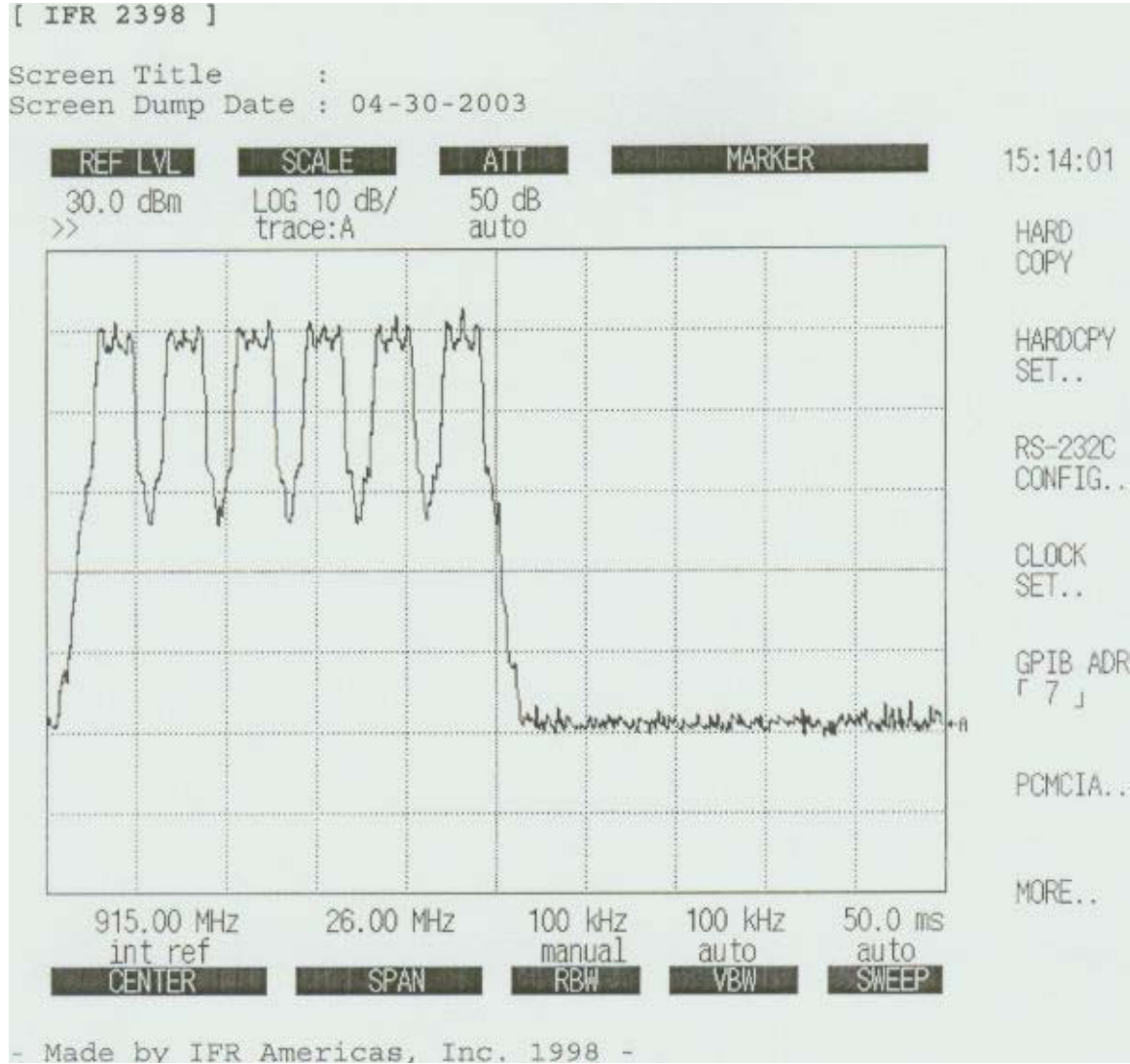

Plot 7

