



Willow Run Test Labs, LLC  
8501 Beck Road, Building 2227  
Belleville, Michigan 48111 USA  
Tel: (734) 252-9785  
Fax: (734) 926-9785  
e-mail: info@wrtest.com

Testing of  
**Electromagnetic Emissions**

per



**USA: CFR Title 47, Part 15.249 (Emissions)**  
**USA: CFR Title 47, Part 2.1091;2.1093 (Exposure)**  
**Canada: ISED RSS-210/GENe (Emissions)**  
**Canada: ISED RSS-102 (Exposure)**

are herein reported for

**Lionel, LLC**  
**LIONCHIEF**

Test Report No.: 20160826-RPTLION10001Ar1  
Copyright © 2016

Applicant/Provider:  
Lionel, LLC  
6301 Performance Drive, Concord NC 28027 United States  
Phone: (586) 421-9022, Fax: (704) 455-8940  
Contact Person: Jim Rohde; jrohde@lionel.com

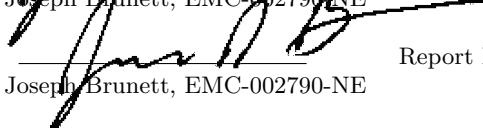
Measured by:  Report Approved by:   
Dr. Joseph Brunett, EMC-002790-NE Dr. Joseph Brunett, EMC-002790-NE  
Report by:  Report Date of Issue: August 26, 2016  
Dr. Joseph Brunett, EMC-002790-NE

**Results of testing completed on (or before) August 15, 2016 are as follows.**

**Emissions:** The transmitter intentional emissions **COMPLY** with the regulatory limit(s) by no less than 15.5 dB. Transmit chain spurious or harmonic emissions **COMPLY** by no less than 9.3 dB. Unintentional spurious emissions from digital circuitry **COMPLY** with radiated emission limit(s) by at least 20 dB.

## Revision History

Rev. No.	Date	Details	Revised By
r0	August 26, 2016	Initial Release.	J. Brunett
r1	August 26, 2016	Typographical Corrections.	J. Brunett

## Contents

<b>Revision History</b>	<b>2</b>
<b>Table of Contents</b>	<b>2</b>
<b>1 Test Specifications, Procedures, Location, and Equipment List</b>	<b>4</b>
1.1 Test Specification and General Procedures . . . . .	4
1.2 Test Location . . . . .	5
1.3 Equipment Used . . . . .	5
<b>2 Configuration and Identification of the Equipment Under Test</b>	<b>6</b>
2.1 Description and Declarations . . . . .	6
2.1.1 EUT Configuration . . . . .	6
2.1.2 Modes of Operation . . . . .	7
2.1.3 Variants . . . . .	7
2.1.4 Test Samples . . . . .	7
2.1.5 Functional Exerciser . . . . .	7
2.1.6 Modifications Made . . . . .	7
2.1.7 Production Intent . . . . .	7
2.1.8 Declared Exemptions and Additional Product Notes . . . . .	7
<b>3 Emissions</b>	<b>8</b>
3.1 General Test Procedures . . . . .	8
3.1.1 Radiated Test Setup and Procedures . . . . .	8
3.1.2 Conducted Emissions Test Setup and Procedures . . . . .	10
3.1.3 Power Supply Variation . . . . .	10
3.1.4 Thermal Variation . . . . .	10
3.2 Intentional Emissions . . . . .	11
3.2.1 Fundamental Emission Pulsed Operation . . . . .	11
3.2.2 Fundamental Emission Bandwidth . . . . .	13
3.2.3 Fundamental Emission Field Strength . . . . .	15
3.2.4 Exposure and Potential Health Hazard . . . . .	16
3.3 Unintentional Emissions . . . . .	17
3.3.1 Transmit Chain Spurious Emissions . . . . .	17
3.3.2 Radiated Digital Spurious . . . . .	18
<b>4 Measurement Uncertainty</b>	<b>19</b>
<b>List of Tables</b>	
1 Test Site List. . . . .	5
2 Equipment List. . . . .	5
3 EUT Declarations. . . . .	6
4 Fundamental Emission Pulsed Operation. . . . .	11
5 Fundamental Emission Bandwidth. . . . .	13

6 Fundamental Emission Field Strength. . . . . 15  
7 Electromagnetic Field Exposure. . . . . 16  
8 Transmit Chain Spurious Emissions. . . . . 17  
9 Measurement Uncertainty. . . . . 19

**List of Figures**

1 Photos of EUT. . . . . 6  
2 EUT Test Configuration Diagram. . . . . 6  
3 Radiated Emissions Diagram of the EUT. . . . . 8  
4 Radiated Emissions Test Setup Photograph(s). . . . . 9  
5 Fundamental Emission Pulsed Operation. . . . . 12  
6 Fundamental Emission Bandwidth. . . . . 14

# 1 Test Specifications, Procedures, Location, and Equipment List

## 1.1 Test Specification and General Procedures

The ultimate goal of Lionel, LLC is to demonstrate that the Equipment Under Test (EUT) complies with the Rules and/or Directives below. Detailed in this report are the results of testing the Lionel, LLC LIONCHIEF for compliance to:

Country/Region	Rules or Directive	Referenced Section(s)
United States	Code of Federal Regulations	CFR Title 47, Part 15.249
Canada	ISED Canada	ISED RSS-210/GENe

Lionel, LLC has determined that the equipment under test is subject to the rules and directives above at the date of this testing. In conjunction with these rules and directives, the following specifications and procedures are followed herein to demonstrate compliance (in whole or in part) with these regulations.

ANSI C63.4:2014	"Methods of Measurement of Radio-Noise Emissions from Low-Voltage Electrical and Electronic Equipment in the Range of 9 kHz to 40 GHz"
ANSI C63.10:2013 (USA)	"American National Standard of Procedures for Compliance Testing of Unlicensed Wireless Devices"
CFR 47 2.1091/1093	"447498 D01 General RF Exposure Guidance v06: RF Exposure Procedures and Equipment Authorization Policies for Mobile and Portable Devices"
ISED Canada	"The Measurement of Occupied Bandwidth"
ICES-003; Issue 6 (2016)	"Information Technology Equipment (ITE) Limits and methods of measurement"
ISED Canada RSS-102	"Radio Frequency (RF) Exposure Compliance of Radiocommunication Apparatus (All Frequency Bands)"

## 1.2 Test Location

The EUT was fully tested by **Willow Run Test Labs, LLC**, 8501 Beck Road, Building 2227, Belleville, Michigan 48111 USA. Test Facility description and attenuation characteristics are on file with the FCC Laboratory, Columbia, Maryland (FCC Reg. No: 688478) and with ISED Canada, Ottawa, ON (File Ref. No: IC 8719A-1). Table 1 lists all site(s) employed herein. Specific test sites utilized are also listed in the test results sections of this report.

Table 1: Test Site List.

Description	Location	Quality Num.
OATS (3 meter)	8501 Beck Rd. Bldg 2227, Belleville MI 48111	OATSA

## 1.3 Equipment Used

Pertinent test equipment used for measurements at this facility is listed in Table 2. The quality system employed at Willow Run Test Labs, LLC has been established to ensure all equipment has a clearly identifiable classification, calibration expiry date, and that all calibrations are traceable to the SI through NIST, other recognized national laboratories, accepted fundamental or natural physical constants, ratio type of calibration, or by comparison to consensus standards.

Table 2: Equipment List.

Description	Manufacturer/Model	SN	Quality Num.	Last Cal By / Date Due
Spectrum Analyzer	Rhode-Schwarz / FSV30	101660	RSFSV30001	RS / May-2018
Spectrum Analyzer	Rhode-Schwarz / FSV4	101222	RSFSV4001	RS / Mar-2018
LS-Band Horn	JEF / NRL Std.	001	HRN15001	WRTL / Jul-2017
Quad Ridge Horn	ETS Lind. / 3164-04	00066988	HRNQR316401	Lib. Labs / April-2017
Quad Ridge Horn	Singer / A6100	C35200	HQR2TO18S01	Lib. Labs / April-2017
K-Band Horn	JEF / NRL Std.	001	HRNK01	WRTL / Jul-2017

## 2 Configuration and Identification of the Equipment Under Test

### 2.1 Description and Declarations

The equipment under test is an remote control transmitter for controlling model trains. The EUT is approximately 18 x 9 x 3 cm (approx.) in dimension, and is depicted in Figure 1. It is powered by a 4.5 VDC three AA Alkaline batteries. In use, this device is hand held. Table 3 outlines provider declared EUT specifications.



Figure 1: Photos of EUT.

Table 3: EUT Declarations.

General Declarations			
<b>Equipment Type:</b>	Train Remote Control	<b>Country of Origin:</b>	Not Declared
<b>Nominal Supply:</b>	4.5 VDC	<b>Oper. Temp Range:</b>	Not Declared
<b>Frequency Range:</b>	2404 – 2476 MHz	<b>Antenna Dimension:</b>	Not Declared
<b>Antenna Type:</b>	integral	<b>Antenna Gain:</b>	Integral
<b>Number of Channels:</b>	18	<b>Channel Spacing:</b>	Not Declared
<b>Alignment Range:</b>	Not Declared	<b>Type of Modulation:</b>	GFSK
United States			
<b>FCC ID Number:</b>	LIV-LCUNIVREM	<b>Classification:</b>	DXT
Canada			
<b>IC Number:</b>	7032A-LCUNIVREM	<b>Classification:</b>	Remote Control Device

#### 2.1.1 EUT Configuration

The EUT is configured for testing as depicted in Figure 2.

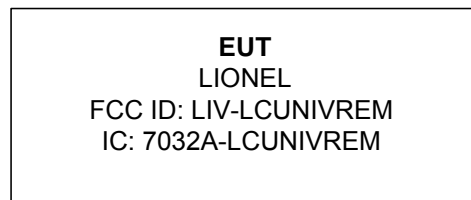

Figure 2: EUT Test Configuration Diagram.

### **2.1.2 Modes of Operation**

When manually activated by button press the EUT transmits control signals to a paired Lionel train or train controller.

### **2.1.3 Variants**

There is only a single electrical variant of the EUT.

### **2.1.4 Test Samples**

One sample was provided with custom software to enable continuous modulated transmission of both the radio under test and the BLE modular radio included in the EUT.

### **2.1.5 Functional Exerciser**

Normal operating EUT functionality was verified by observation of transmitted signal.

### **2.1.6 Modifications Made**

There were no modifications made to the EUT by this laboratory.

### **2.1.7 Production Intent**

The EUT appears to be a fully functional pre-production (SLA/printed chassis) sample.

### **2.1.8 Declared Exemptions and Additional Product Notes**

In addition to the 2404-2476 MHz radio tested herein, the EUT employs a BLE modular radio to interface with other train control systems. That BLE radio is a pre-approved module (FCC ID:2AH7AKW2541A, IC: 21416-KW2541A) and has been tested along with the radio in this report for intermodulation products and RF exposure to confirm co-location requirements are met.

### 3 Emissions

#### 3.1 General Test Procedures

##### 3.1.1 Radiated Test Setup and Procedures

Radiated electromagnetic emissions from the EUT are first pre-scanned in our shielded anechoic chamber or GTEM test cell. Spectrum and modulation characteristics of all emissions are recorded. Instrumentation, including spectrum analyzers and other test equipment as detailed in Section 1.2 are employed. After pre-scan, emission measurements are made on the test site of record. If the EUT connects to auxiliary equipment and is table or floor standing, the configurations prescribed in relevant test standards are followed. Alternatively, a layout closest to normal use (as declared by the provider) is employed if the resulting emissions appear to be worst-case in such a configuration. See Figure 3. All intentionally radiating elements that are not fixed-mounted in use are placed on the test table lying flat, on their side, and on their end (3-axes) and the resulting worst case emissions are recorded. If the EUT is fixed-mounted in use, measurements are made with the device oriented in the manner consistent with installation and then emissions are recorded.

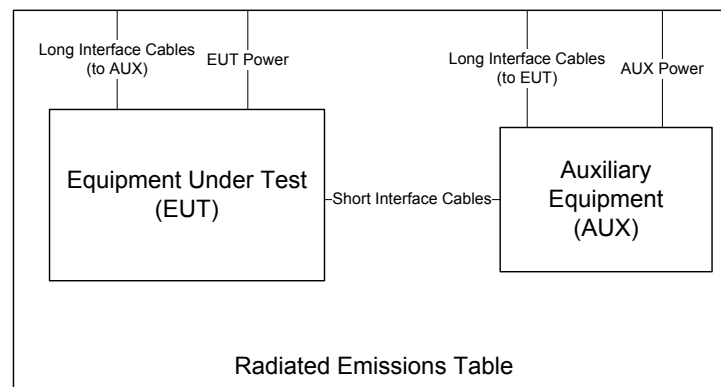

Figure 3: Radiated Emissions Diagram of the EUT.

If the EUT exhibits spurious emissions due to internal receiver circuitry, such emissions are measured with an appropriate carrier signal applied. For devices with intentional emissions below 30 MHz, a shielded loop antenna is used. It is placed at a 1 meter receive height. Emissions between 30 MHz and 1 GHz are measured using tuned dipoles and/or calibrated broadband antennas. For both horizontal and vertical polarizations, the test antenna is raised and lowered from 1 to 4 m in height until a maximum emission level is detected. The EUT is then rotated through 360° in azimuth until the highest emission is detected. The test antenna is then raised and lowered one last time from 1 to 4 m and the worst case value is recorded. Emissions above 1 GHz are characterized using standard gain horn or broadband ridge-horn antennas on our OATS with a 4 × 5 m rectangle of H-4 absorber placed over the ground screen covering the OATS ground screen. Care is taken to ensure that test receiver resolution and video bandwidths meet the regulatory requirements, and that the emission bandwidth of the EUT is not reduced. Photographs of the test setup employed are depicted in Figure 4.

Where regulations allow for direct measurement of field strength, power values (dBm) measured on the test receiver / analyzer are converted to dBμV/m at the regulatory distance, using

$$E_{dist} = 107 + P_R + K_A - K_G + K_E - C_F$$

where  $P_R$  is the power recorded on spectrum analyzer, in dBm,  $K_A$  is the test antenna factor in dB/m,  $K_G$  is the combined pre-amplifier gain and cable loss in dB,  $K_E$  is duty correction factor (when applicable) in dB, and  $C_F$  is a distance conversion (employed only if limits are specified at alternate distance) in dB. This field strength value is then compared with the regulatory limit. If effective isotropic radiated power (EIRP) is computed, it is computed as

$$EIRP(dBm) = E_{3m}(dB\mu V/m) - 95.2.$$

When presenting data at each frequency, the highest measured emission under all possible EUT orientations (3-axes) is reported.





Figure 4: Radiated Emissions Test Setup Photograph(s).

### 3.1.2 Conducted Emissions Test Setup and Procedures

**Battery Power Conducted Spurious** The EUT is not subject to measurement of power line conducted emissions as it is powered solely by its internal battery.

### 3.1.3 Power Supply Variation

Tests at extreme supply voltages are made if required by the the procedures specified in the test standard, and results of this testing are detailed in this report.

In the case the EUT is designed for operation from a battery power source, the extreme test voltages are evaluated over the range specified in the test standard; no less than  $\pm 10\%$  of the nominal battery voltage declared by the manufacturer. For all battery operated equipment, worst case intentional and spurious emissions are re-checked employing a new (fully charged) battery.

### 3.1.4 Thermal Variation

Tests at extreme temperatures are made if required by the procedures specified in the test standard, and results of this testing are detailed in this report. The provider has declared that the EUT is designed for operation over the temperature range Not Declared. Before any temperature measurements are made, the equipment is allowed to reach a thermal balance in the test chamber, temperature and humidity are recorded, and thermal balance is verified via a thermocouple-based probe.

### 3.2 Intentional Emissions

#### 3.2.1 Fundamental Emission Pulsed Operation

**Test Setup & Procedure** The test equipment and facilities were setup in accordance with the standards and procedures listed in Section 1.1. Environmental conditions were set at the appropriate temperature and thermal balance was checked with a thermocouple based probe. Duty cycle is reported for all relevant modes of operation. The test equipment employed includes RSFSV30001, HRN15001.

**Measurement Results** The details and results of testing the EUT are summarized in Table 4. Plots showing the measurements made to obtain these values are provided in Figure 5.

Table 4: Fundamental Emission Pulsed Operation.

<b>Frequency Range</b>	<b>Det</b>	<b>IFBW</b>	<b>VBW</b>	<b>Test Date:</b>	8-Aug-16
f > 1 000 MHz	Pk	5 MHz	5 MHz	<b>Test Engineer:</b>	Joseph Brunett
				<b>EUT</b>	LIONCHIEF
				<b>Meas. Distance:</b>	10cm

Pulsed Operation / Duty Cycle									
Transmit Mode	Symbol Rate (Msym/s)	Data Rate* (Mbps)	Voltage (V)	Oper. Freq (MHz)	Cycle Time* (ms)	On-Time* (ms)	Duty Cycle (%)	Field Strength Duty Correction** (dB)	Exposure Duty Correction*** (dB)
GFSK	-	-	3.0	2440.0	12.50	0.17	1.368	37.3	18.6

\* Measurement of cycle time and on-time were verified to be independent of IFBW for IFBW >= 1 MHz for all modulations and channels.

\*\* E-field duty cycle correction (due to burst-modulated carrier) computed as 20\*Log(On-Time/Cycle-Time)

\*\*\* Exposure duty cycle correction (due to burst-modulated carrier) computed as 10\*Log(On-Time/Cycle-Time)

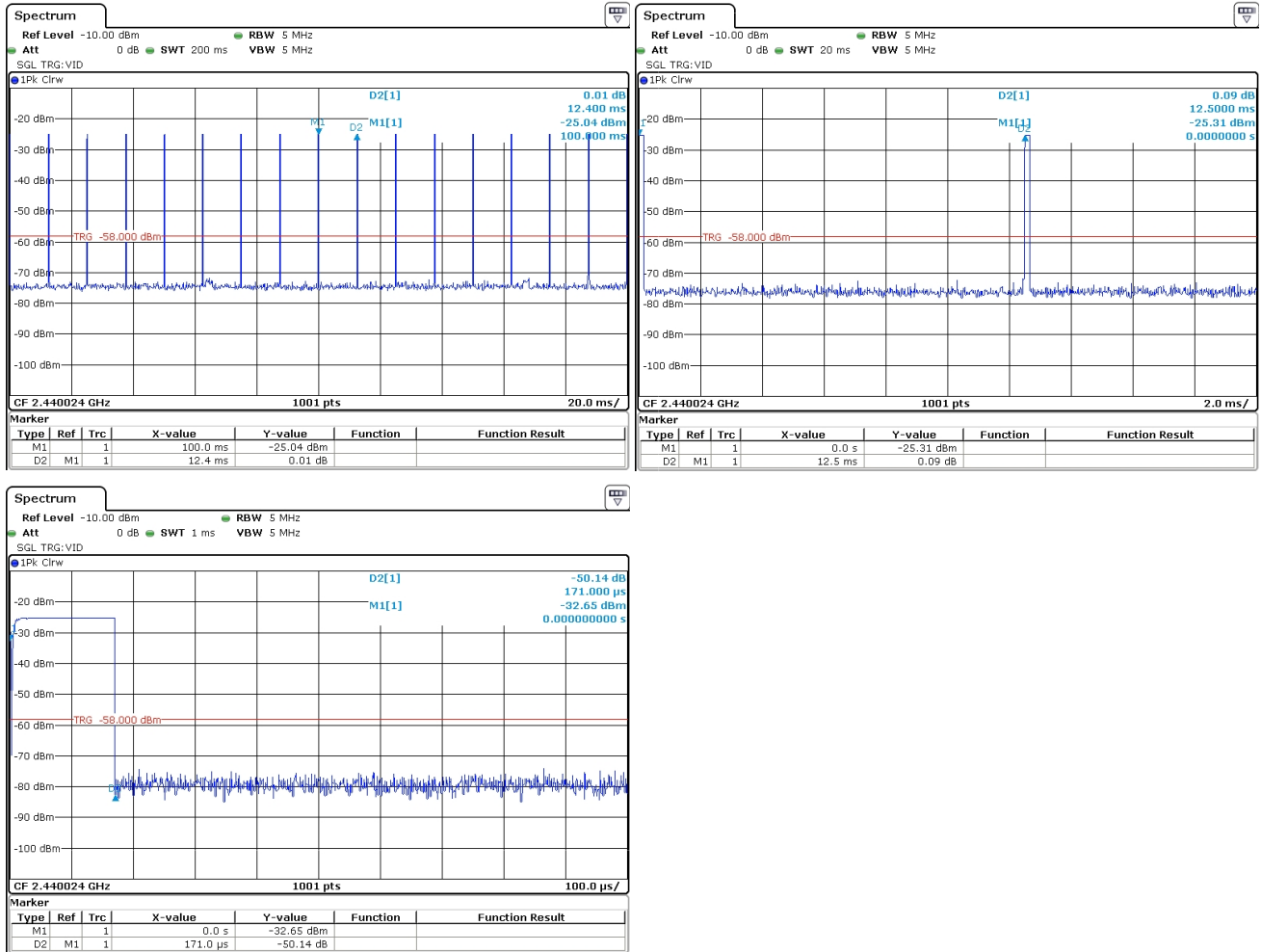

Figure 5: Fundamental Emission Pulsed Operation.

### 3.2.2 Fundamental Emission Bandwidth

**Test Setup & Procedure** The test equipment and facilities were setup in accordance with the standards and procedures listed in Section 1.1. Environmental conditions were set at the appropriate temperature and thermal balance was checked with a thermocouple based probe. Emission bandwidth (EBW) of the EUT is measured with the device placed in the test mode(s) with the shortest available frame length and minimum frame spacing. The 20 dB EBW is measured as the max-held peak-detected signal when the IF bandwidth is greater than or equal to 1% of the receiver span. For complex modulations other than ASK and FSK, the 99% emission bandwidth per IC test procedures has a different result, and is also reported. The test equipment employed includes RSFSV30001, HRN15001.

**Measurement Results** The details and results of testing the EUT are summarized in Table 5. Plots showing the measurements made to obtain these values are provided in Figure 6.

Table 5: Fundamental Emission Bandwidth.

<b>Frequency Range</b>	<b>Det</b>	<b>IFBW</b>	<b>VBW</b>	<b>Span</b>	<b>Test Date:</b>	7-Aug-16
f > 1 000 MHz	Pk	100 kHz	100 kHz	10 MHz	<b>Test Engineer:</b>	Joseph Brunett
					<b>EUT</b>	LIONCHIEF
					<b>Meas. Distance:</b>	10 cm

Occupied Bandwidth									
Transmit Mode	Symbol Rate (Msym/s)	Data Rate (Mbps)	Voltage (V)	Oper. Freq (MHz)	99% OBW (MHz)	20 dB EBW (MHz)			Pass/Fail
GFSK	-	-	3.0	2404.0	5.644	5.495			Pass
				2440.0	4.785	4.655			
				2476.0	3.836	3.596			

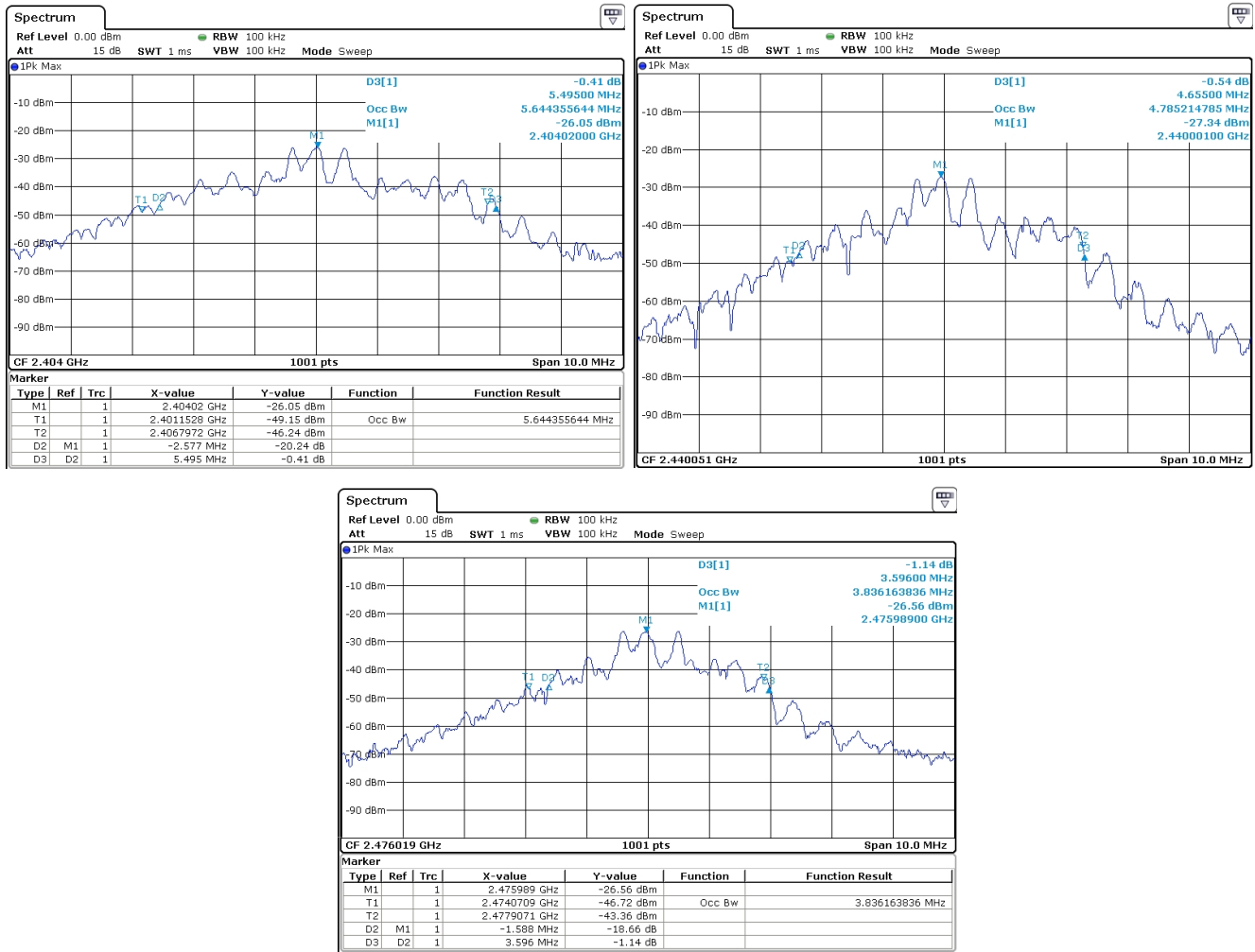

Figure 6: Fundamental Emission Bandwidth.

### 3.2.3 Fundamental Emission Field Strength

**Test Setup & Procedure** The test equipment and facilities were setup in accordance with the standards and procedures listed in Section 1.1. Environmental conditions were set at the appropriate temperature and thermal balance was checked with a thermocouple based probe. Fundamental emissions are measured at the regulatory distance on our OATS. The test equipment employed includes RSFSV30001, HRN15001.

**Measurement Results** The details and results of testing the EUT are summarized in Table 6.

Table 6: Fundamental Emission Field Strength.

<b>Frequency Range</b>	<b>Det</b>	<b>IF Bandwidth</b>	<b>Video Bandwidth</b>	<b>Test Date:</b>	7-Aug-16
25 MHz f 1 000 MHz	Pk/QPk	120 kHz	300 kHz	<b>Test Engineer:</b>	Joseph Brunett
f > 1 000 MHz	Pk/Avg	1 MHz	3 MHz	<b>EUT:</b>	LIONCHIEF
				<b>Mode:</b>	Cont. Mod. Tx.
				<b>Meas. Distance:</b>	3m

														FCC/IC
#	Freq. Start MHz	Freq. Stop MHz	Ant. Used	Ant. Pol.	Pr (Pk) dBm	Pr (Avg)* dBm	Ka dB/m	Kg dB	E3(Pk) dBµV/m	E3 Pk Lim dBµV/m	E3(Avg) dBµV/m	E3 Avg Lim dBµV/m	Pass dB	Comments
1	2404.0	2404.0	HRNQR316401	H/V	-30.8	-68.1	21.4	-0.4	98.0	114.0	60.7	94.0	16.0	
2	2440.0	2440.0	HRNQR316401	H/V	-31.1	-68.4	21.5	-0.4	97.8	114.0	60.6	94.0	16.1	
3	2476.0	2476.0	HRNQR316401	H/V	-30.6	-67.9	21.7	-0.4	98.5	114.0	61.2	94.0	15.5	
4														
5														

\*Avg computed from Pk measurement by applying duty cycle.

### 3.2.4 Exposure and Potential Health Hazard

To demonstrate compliance with with regulations that place limitations on human electromagnetic field exposure for both the general public and for workers, we compute EIRP from measured emission data. These levels are compared with limits placed by the directives and recommendations detailed in Section 1.1. Table 7 details the results of these computations.

Table 7: Electromagnetic Field Exposure.

USA REF: 2.1091/1093, 447498 D01 General RF Exposure Guidance v06  
 IC REF: RSS-102 Issue 5  
 Min. Sep. Distance: <5mm

Test Date: 7-Aug-16  
 Test Engineer: Joseph Brunett  
 EUT: LIONCHIEF  
 EUT Mode: Cont. Mod. Tx.  
 Meas. Distance: 3 meters

Radio	Freq. MHz	E3m* Pk dBuV/m	EIRP*** Pk dBm	Exposure Duty dB	Worst Case EIRP(Avg)**		Canada			USA		
					dBm	mW	Calculated SAR Threshold (Avg)*** mW	1-g SAR Body Power Threshold Exclusion Limit (Avg) mW	10-g SAR Extremity Power Threshold Exclusion Limit (Avg) mW	Calculated SAR Threshold (Avg)	1-g SAR Body Power Threshold Exclusion Limit (Avg)	10-g SAR Extremity Power Threshold Exclusion Limit (Avg)
BLE Module	2402.0	92.3	-2.9	-	-11.9	0.06						
	2440.0	90.7	-4.5	-	-13.0	0.05						
	2480.0	90.7	-4.5	-	-13.0	0.05						
DXT Radio	2404.0	98.0	2.8	18.6	-15.9	0.03	0.09	4.0	10.0	0.03	3.0	7.5
	2440.0	97.8	2.6	18.6	-16.0	0.03	0.08	4.0	10.0	0.02	3.0	7.5
	2476.0	98.5	3.3	18.6	-15.3	0.03	0.08	4.0	10.0	0.03	3.0	7.5

\*As Measured / Computed from highest fundamental emission, see fundamental emission section of this report.  
 \*\*Only RMS level is required, RMS/6min << Pk, Peak emission employed to demonstrate compliance.  
 \*\*\*Sum of Worst Case EIRP from both radios at low, middle, and high channels assuming both transmit at the same channel at a given time.



### 3.3 Unintentional Emissions

#### 3.3.1 Transmit Chain Spurious Emissions

**Test Setup & Procedure** The test equipment and facilities were setup in accordance with the standards and procedures listed in Section 1.1. Environmental conditions were set at the appropriate temperature and thermal balance was checked with a thermocouple based probe. Spurious radiated emissions measurements are performed to 10 times the highest fundamental operating frequency. The test equipment employed includes RSFSV30001, HRN15001, HQR2TO18S01,HRNK01.

**Measurement Results** The details and results of testing the EUT are summarized in Table 8.

Table 8: Transmit Chain Spurious Emissions.

<b>Frequency Range</b>	<b>Det</b>	<b>IF Bandwidth</b>	<b>Video Bandwidth</b>	<b>Test Date:</b>	7-Aug-16
25 MHz f 1 000 MHz	Pk/QPk	120 kHz	300 kHz	<b>Test Engineer:</b>	Joseph Brunett
f > 1 000 MHz	Pk/Avg	1 MHz	3 MHz	<b>EUT:</b>	LIONCHIEF
				<b>Mode:</b>	Cont. Mod. Tx.
				<b>Meas. Distance:</b>	3m

														FCC/IC
#	Freq. Start MHz	Freq. Stop MHz	Ant. Used	Ant. Pol.	Pr (Pk) dBm	Pr (Avg)* dBm	Ka dB/m	Kg dB	E3(Pk) dBµV/m	E3 Pk Lim dBµV/m	E3(Avg) dBµV/m	E3 Avg Lim dBµV/m	Pass dB	Comments
1	Fundamental Restricted Band Edge (Low Side)													
2	2400.0	2400.0	15CMLSHRN	H/V	-74.5	-111.8	21.3	-0.4	54.2	74.0	17.0	54.0	19.8	** MKR-Delta Method
3	Fundamental Restricted Band Edge (High Side)													
4	2483.5	2483.5	15CMLSHRN	H/V	-64.5	-101.8	21.8	-0.4	64.7	74.0	27.4	54.0	9.3	
5	Inter-modulation Products (Test Radio L+H channels with BLE module cont. Tx L+H channels)													
6	2328.0	2328.0	15CMLSHRN	H/V	-71.9	-109.2	21.1	-0.4	56.6	74.0	19.3	54.0	17.4	
	2556.0	2556.0	15CMLSHRN	H/V	-75.2	-112.5	22.2	-0.4	54.4	74.0	17.1	54.0	19.6	
7	2328.0	2328.0	15CMLSHRN	H/V	-72.3	-109.6	21.1	-0.4	56.2	74.0	18.9	54.0	17.8	
8	2550.0	2550.0	15CMLSHRN	H/V	-76.7	-114.0	22.1	-0.4	52.8	74.0	15.6	54.0	21.2	
9	Harmonic / Spurious Emissions													
10	4808.0	4804.0	HQR2TO18S01	H/V	-92.1	-129.4	35.5	-0.8	51.2	74.0	14.0	54.0	22.7	
11	4880.0	4805.0	HQR2TO18S01	H/V	-93.4	-130.7	35.5	-0.8	49.9	74.0	12.6	54.0	24.1	
12	4950.0	4806.0	HQR2TO18S01	H/V	-90.0	-127.3	35.5	-0.8	53.3	74.0	16.0	54.0	20.7	
13	4000.0	6000.0	HQR2TO18S01	H/V	-90.0	-127.3	32.8	-0.8	50.6	74.0	13.3	54.0	23.4	
14	7212.0	7212.0	HQR2TO18S01	H/V	-78.9	-116.2	33.3	-1.2	62.6	74.0	25.3	54.0	11.4	
15	7320.0	7320.0	HQR2TO18S01	H/V	-79.6	-116.9	33.4	-1.2	62.0	74.0	24.7	54.0	12.0	
16	7425.0	7425.0	HQR2TO18S01	H/V	-83.2	-120.5	33.4	-1.2	58.4	74.0	21.2	54.0	15.6	
17	6000.0	8400.0	HQR2TO18S01	H/V	-78.9	-116.2	34.3	-1.2	63.6	74.0	26.3	54.0	10.4	
18	8400.0	12500.0	HQR2TO18S01	H/V	-97.8	-135.1	35.6	-2.0	46.8	74.0	9.6	54.0	27.2	
19	12500.0	18000.0	HQR2TO18S01	H/V	-99.6	-136.9	34.3	-3.1	44.8	74.0	7.6	54.0	29.2	
20	18000.0	26500.0	HRNK001	H/V	-97.8	-135.1	33.7	-3.9	46.8	74.0	9.5	54.0	27.2	
21														
22														
23														

\*Avg computed from Pk by applying duty cycle.

\*Pk Measured using Mkr-Delta Method. 2404MHz Pk = -30.8 dBm, Delta to 2400MHz in 10 kHz RBW = 44.0 dB.

### **3.3.2 Radiated Digital Spurious**

The results for the measurement of digital spurious emissions are not reported herein as all digital emissions were greater than 20 dB below the regulatory limit. Radiation from digital components was measured to 4 GHz, or to five times the maximum digital component operating frequency, whichever is greater.

## 4 Measurement Uncertainty

The maximum values of measurement uncertainty for the laboratory test equipment and facilities associated with each test are given in the table below. This uncertainty is computed for a 95.45% confidence level based on a coverage factor of  $k = 2$ .

Table 9: Measurement Uncertainty.

Measured Parameter	Measurement Uncertainty <sup>†</sup>
Radio Frequency	$\pm(f_{Mkr}/10^7 + RBW/10 + (SPN/(PTS - 1))/2 + 1 \text{ Hz})$
Conducted Emm. Amplitude	$\pm 1.8 \text{ dB}$
Radiated Emm. Amplitude (30 – 200 MHz)	$\pm 2.7 \text{ dB}$
Radiated Emm. Amplitude (200 – 1000 MHz)	$\pm 2.5 \text{ dB}$
Radiated Emm. Amplitude ( $f > 1000 \text{ MHz}$ )	$\pm 3.7 \text{ dB}$
DC and Low Frequency Voltages	$\pm 2\%$
Temperature	$\pm 0.5^\circ\text{C}$
Humidity	$\pm 5\%$

<sup>†</sup>Ref: CISPR 16-4-2:2011+A1:2014