



**TEST REPORT**

**Report Number: 3134607LEX-003**  
**Project Number: 3134607**

**Evaluation of the G80050AUAL**  
**Model Number: G80050AUAL**  
**FCC ID: LHJGEN80CNT**  
**Industry Canada ID: 2807E-GEN80CNT**

**FCC Part 22 Subpart H**  
**FCC Part 24 Subpart E**  
**FCC Part 15 Subpart B**  
**RSS-129**  
**RSS-133**

**For**

**Continental Automotive Systems**

Test Performed by:  
Intertek  
731 Enterprise Drive  
Lexington, KY 40510

Test Authorized by:  
Continental Automotive Systems  
21440 West Lake Cook Road  
Deer Park, IL 60010

Prepared By: *Bryan C. Taylor* Date: 1/3/2008

Bryan C. Taylor, EMC Team Leader

Approved By: *Jason Centers* Date: 1/3/2008

Jason Centers, Senior Project Engineer

This report is for the exclusive use of Intertek's Client and is provided pursuant to the agreement between Intertek and its Client. Intertek's responsibility and liability are limited to the terms and conditions of the agreement. Intertek assumes no liability to any party, other than to the Client in accordance with the agreement, for any loss, expense or damage occasioned by the use of this report. Only the Client is authorized to copy or distribute this report and then only in its entirety. Any use of the Intertek name or one of its marks for the sale or advertisement of the tested material, product or service must first be approved in writing by Intertek. The observations and test results in this report are relevant only to the sample tested. This report by itself does not imply that the material, product, or service is or has ever been under an Intertek certification program.

**Intertek**

731 Enterprise Drive, Lexington, KY 40510

Telephone: 859-226-1000 Fax: 859-226-1040 Web: www.etlsemko.com



**TABLE OF CONTENTS**

**1 JOB DESCRIPTION ..... 4**

1.1 COMPANY INFORMATION ..... 4

1.2 TEST SAMPLE INFORMATION ..... 4

1.3 SYSTEM SUPPORT EQUIPMENT ..... 5

1.4 CABLES USED DURING TESTING ..... 5

1.5 SYSTEM BLOCK DIAGRAM(S) ..... 6

1.6 MODE(S) OF OPERATION / ENGINEERING JUDGMENTS ..... 6

**2 EXECUTIVE SUMMARY..... 7**

2.1 MODIFICATIONS REQUIRED FOR COMPLIANCE ..... 8

**3 TEST FACILITY..... 9**

3.1 TEST EQUIPMENT..... 9

**4 CONDUCTED RF POWER ..... 10**

4.1 TEST PROCEDURE ..... 10

4.2 TEST RESULTS ..... 10

**5 RADIATED RF POWER..... 11**

5.1 TEST PROCEDURE ..... 11

5.2 TEST RESULTS ..... 11

**6 MAXIMUM PERMISSIBLE EXPOSURE (MPE) CALCULATIONS ..... 12**

6.1 CALCULATIONS..... 12

6.2 TEST RESULTS ..... 12

**7 EMISSION LIMITATIONS, OCCUPIED BANDWIDTH ..... 13**

7.1 TEST PROCEDURE ..... 13

7.2 TEST RESULTS ..... 13

**8 OUT OF BAND EMISSION AT ANTENNA TERMINALS..... 17**

8.1 TEST PROCEDURE ..... 17

8.2 TEST RESULTS ..... 18

**9 RADIATED SPURIOUS EMISSIONS..... 33**

9.1 TEST PROCEDURE ..... 33

9.2 TEST RESULTS ..... 33

**10 MODULATION LIMITING, TX AUDIO FREQUENCY RESPONSE, SIDEBAND  
 POWER ATTENUATION..... 39**

Evaluation For: Continental Automotive Systems  
Model No: G80050AUAL

FCC ID: LHJGEN80CNT  
ICID:2807E-GEN80CNT

---

10.1	TEST PROCEDURE .....	39
10.2	TEST RESULTS .....	40
<b>11</b>	<b>RECEIVER SPURIOUS EMISSIONS .....</b>	<b>45</b>
11.1	TEST LIMITS.....	45
11.2	TEST PROCEDURE .....	45
11.3	TEST RESULTS .....	46
<b>12</b>	<b>FREQUENCY STABILITY VS TEMPERATURE .....</b>	<b>47</b>
12.1	TEST PROCEDURE .....	47
12.2	TEST RESULTS .....	47
<b>13</b>	<b>FREQUENCY STABILITY VS VOLTAGE .....</b>	<b>48</b>
13.1	TEST PROCEDURE .....	48
13.2	TEST RESULTS .....	48

Evaluation For: Continental Automotive Systems  
 Model No: G80050AUAL

FCC ID: LHJGEN80CNT  
 ICID: 2807E-GEN80CNT

## 1 JOB DESCRIPTION

### 1.1 Company Information

Company Information	
<b>Manufacturer:</b>	Continental Automotive Systems
<b>Address:</b>	21440 West Lake Cook Road Deer Park IL 60010
<b>Contact Name:</b>	James Zhang
<b>Telephone Number:</b>	(847) 862-1264

### 1.2 Test Sample Information

The G80050AUAL is an in-vehicle OnStar system.

Test sample			
<b>Model Number:</b>	G80050AUAL		
<b>Serial Number:</b>	Test Sample 1		
<b>FCC ID:</b>	LHJGEN80CNT		
<b>ICID:</b>	2807E-GEN80CNT		
<b>Device Category:</b>	Mobile		
<b>RF Exposure Category:</b>	General Population/Uncontrolled Environment		
<b>Transmission Modes:</b>	<b>AMPS</b>	<b>CDMA Cell</b>	<b>CDMA PCS</b>
<b>Frequency Range, MHz:</b>	824MHz - 849MHz	824MHz - 849MHz	1850MHz – 1910MHz
<b>Maximum Conducted RF Output Power:</b>	27.6dBm	24.91dBm	25.67dBm
<b>Antenna Type:</b>	Not Supplied	Not Supplied	Not Supplied
<b>Antenna Location:</b>	Externally Mounted	Externally Mounted	Externally Mounted

**1.3 System Support Equipment**

Table 1-1 contains the details of the support equipment associated with the Equipment Under Test during the testing.

Table 1-1: System Support Equipment

Description	Manufacturer	Model Number	Serial Number
Laptop	Compaq	EVO N410c	3902A783
Power Supply	Hewlett Packard	6226B	6M0366

**1.4 Cables Used During Testing**

Table 1-2 contains the details of the cables used during the testing.

Table 1-2: Interconnecting Cables Used During Testing

Cables					
Description	Length	Shielding	Ferrites	Connection	
				From	To
Multi-Conductor Wiring Harness (Data/Audio)	2 ft	None	None	EUT	Test Interface Box
DC Power	3 ft	None	None	Test Interface Box	DC Power Supply
RS232 Signal	4 ft	Yes	None	Test Interface Box	Laptop
CDMA Antenna Cable	6 ft	Yes	None	CDMA Antenna Port	CDMA Antenna

**1.5 System Block Diagram(s)**

The diagrams below detail the interconnection of the EUT and its accessories during the testing.

Figure 1-1: Radiated Test Configuration

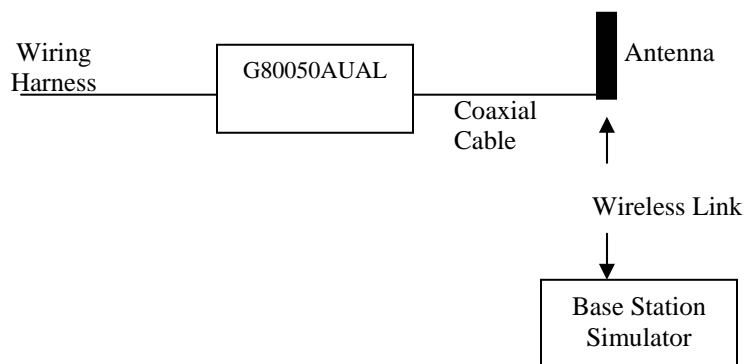
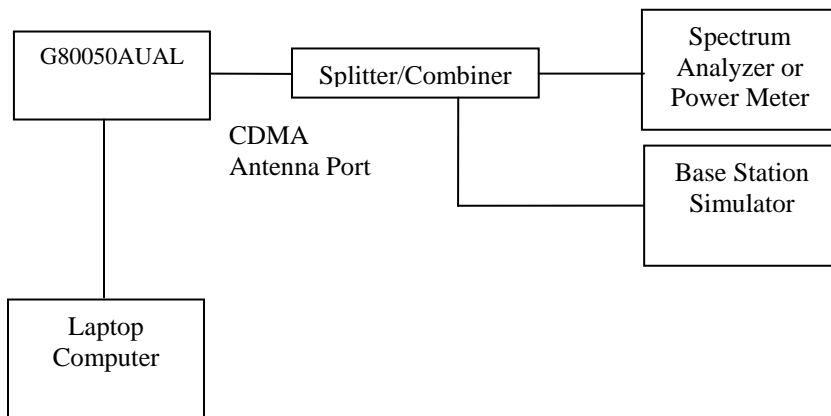

Figure 1-2: Conducted Test Configuration



**1.6 Mode(s) of operation / Engineering Judgments**

The G80050AUAL was powered by a 13VDC laboratory power supply.

For radiated testing, the CDMA antenna was connected to the G80050AUAL. For conducted measurements the antenna was removed and a calibrated coaxial cable inserted between the CDMA port and the measuring equipment (spectrum analyzer or power meter). A base station simulator was used to force the G80050AUAL to transmit at maximum output power.

Evaluation For: Continental Automotive Systems  
 Model No: G80050AUAL

 FCC ID: LHJGEN80CNT  
 ICID:2807E-GEN80CNT

## 2 EXECUTIVE SUMMARY

Testing performed for: Continental Automotive Systems

Equipment Under Test: G80050AUAL

Receipt of Test Sample: 9/4/2007

Test Start Date: 9/5/2007

Test End Date: 9/18/2007

The G80050AUAL was compliant with the requirements of FCC Part §22, Part §24, RSS-129, and RSS-133.

FCC RULE	IC RULE	DESCRIPTION OF TEST	RESULT	PAGE
§2.1046	RSS-129 (9.2.2)	RF Power Output	<b>Compliant</b>	10
§22.913, §24.232	RSS-129 (9.1) RSS-133 (6.4)	ERP, EIRP	<b>Compliant</b>	11
§ 1.1310	NA	Maximum Permissible Exposure (MPE) Calculations	<b>Compliant</b>	11
§2.1049 §22.917(b)(d) §24.238(a)	NA	Occupied Bandwidth, Emissions Limitations	<b>Compliant</b>	13
§2.1051 §22.917(a) §24.238(a)	RSS-129 (8.1.1) RSS-129 (6.3.2) RSS-129 (6.3.3) RSS-133 (6.5.1) RSS-129 (9.3, 9.4) RSS-129 (10)	Out of Band Emissions at Antenna Terminals	<b>Compliant</b>	18
§2.1053 §22.917(a) §24.238(a)	RSS-129 (8.1.1) RSS-133 (6.5.1)	Radiated Spurious Emissions	<b>Compliant</b>	33
§2.1047	RSS-129 (6.1) RSS-129 (6.2) RSS-129 (6.3)	Modulation Limiting, Tx Audio Frequency Response, Sideband Power Attenuation	<b>Compliant</b>	39
§15.107	RSS-Gen [7.2.2]	Power Line Conducted Emissions	<b>NA<sup>1</sup></b>	-
§15.109	RSS-129 (10) RSS-133 (6.7)	Receiver Spurious Emission	<b>Compliant</b>	45
§2.1055, §22.355, §24.235	RSS-129 (9.2.1) RSS-133 (6.3)	Frequency Stability vs. Temperature	<b>Compliant</b>	47
§2.1055, §22.355, §24.235	RSS-129 (9.2.1) RSS-133 (6.3)	Frequency Stability vs. Voltage	<b>Compliant</b>	48

<sup>1</sup> The G80050AUAL is DC powered. This test is only applicable to AC powered devices.

---

Evaluation For: Continental Automotive Systems  
Model No: G80050AUAL

FCC ID: LHJGEN80CNT  
ICID: 2807E-GEN80CNT

## **2.1 Modifications required for compliance**

No modifications were implemented by Intertek. All results in this report pertain to the un-modified sample provided to Intertek.



**3 TEST FACILITY**

All testing was completed at the INTERTEK-Lexington location at 731 Enterprise Drive, Lexington Kentucky, 40510. The radiated emission test site is a 10-meter semi-anechoic chamber. The chamber meets the characteristics of CISPR 16-1 and ANSI C63.4. For measurements, a remotely controlled flush-mount metal-top turntable is used to rotate the EUT a full 360 degrees. A remote controlled non-conductive antenna mast is used to scan the antenna height from one to four meters.



For radiated immunity testing, removable ferrite tiles are positioned between the transmitting antenna and the area occupied by the equipment under test. The remaining tests typically are performed outside the chamber on the conducting ground reference plane.

The Industry Canada filing number for this site is 2055A-1. The FCC registration number is 485103.

**3.1 Test Equipment**

Description	Manufacturer	Model Number	Serial Number	Calibration due date
Environmental Chamber	Thermotron	SM-8C	32692	1/24/2008
Signal Generator	HP	83620B	3614A00199	8/20/2008
Horn Antenna	EMCO	3115	6556	8/2/2008
Horn Antenna	Antenna Research	DRG-118/A	1086	7/20/2008
EMI Receiver	Rohde & Schwarz	ESI 40	1088.7490	5/9/2008
Bilog Antenna	EMCO	3142C	00051864	11/14/2007
Preamplifier	Miteq	AFS44-00102000-30-10P-44	987410	6/19/2008
Digital Multimeter	Fluke	87	1280	3/18/2008
Base Station Simulator	Rhode & Schwarz	CMU200	1100.0008.02	3/29/2008
Base Station Simulator	HP	8920B	US37423763	3/13/2008
Function Generator	HP	3325B	2801A0216	2/21/2008
Modulator Analyzer	HP	8901B	2142A01663	3/22/2008

**4 CONDUCTED RF POWER**

FCC Rule: §2.1046

IC Rule: RSS-129 §7.1, §9.1 and RSS-133 §6.2

**4.1 Test Procedure**

The transmitter output was connected to a calibrated coaxial cable, the other end of which was connected to a Base Station Simulator. The Base Station Simulator was set to force the EUT to its maximum power setting. The EUT was placed into a call and the transmitter output was read off the base station simulator in dBm. The power output at the transmitter antenna port was determined by adding the value of the cable insertion loss to the base station simulator power reading.

Tests were performed at three frequencies (low, middle, and high channels) and on the highest power levels, which can be setup on the transmitters.

**4.2 Test Results**

The G80050AUAL met the RF power output requirements of FCC Part 22 Subpart H and FCC Part FCC Part 24 Subpart E. The test results are shown Table 4-1.

Table 4-1 RF Power Variation with Temperature

Temp	CDMA Cell Band			CDMA PCS Band			AMPS		
	Channel 1013	Channel 384	Channel 777	Channel 25	Channel 600	Channel 1175	Channel 991	Channel 384	Channel 799
-30	25.35	<b>25.67</b>	24.97	<b>24.91</b>	24.66	24.68	27	27.4	27.5
-20	24.73	24.99	24.87	24.79	24.5	24.49	26.9	27.3	27.5
-10	24.65	25.05	24.75	24.73	24.74	24.47	26.9	27.4	27.5
0	24.55	24.78	24.8	24.7	24.72	24.48	27	27.3	27.5
10	24.46	24.85	24.82	24.76	24.67	24.47	27.1	27.4	27.5
20	24.68	24.74	24.8	24.82	24.72	24.61	27	27.4	27.5
30	24.57	25.05	24.93	24.77	24.75	24.54	27.1	27.4	<b>27.6</b>
40	24.46	24.84	24.8	24.78	24.72	24.54	26.9	27.4	27.5
50	24.43	24.78	24.86	24.39	24.32	24.29	27	27.4	27.5
60	24.33	24.53	24.53	24.2	23.98	23.86	26.9	27.4	27.5

## 5 RADIATED RF POWER

FCC Rule §22.913; The Effective Radiated Power (ERP) of mobile transmitters and auxiliary test transmitters must not exceed 7 Watts.

FCC Rule §24.232; RSS-133 §6.2; The equivalent Isotropic Radiated Power (EIRP) must not exceed 2 Watts.

RSS-129 §7.1, §9.1

### 5.1 Test Procedure

Since the device is not supplied with an antenna, the maximum allowed antenna gain is calculated using the maximum measured conducted output power.

#### Cell / AMPS Band:

$$\text{Gain (dBd)} = \text{ERP} - \text{Conducted Output Power (dBm)}$$

$$\text{Gain (dBd)} = 31.76\text{dBm} - 27.6\text{dBm} = 4.16\text{dBd}$$

#### PCS Band:

$$\text{Gain (dBi)} = \text{EIRP} - \text{Conducted Output Power (dBm)}$$

$$\text{Gain (dBi)} = 33\text{dBm} - 24.91\text{dBm} = 8.09\text{dBi}$$

### 5.2 Test Results

The G80050AUAL meets the radiated power requirements of FCC §22.913 and §24.232 when an antenna of no more than 4.4dBd of gain in the cell band and no more than 8.09dBi of gain in the PCS band is used.

**6 MAXIMUM PERMISSIBLE EXPOSURE (MPE) CALCULATIONS**

The § 1.1310 Radiofrequency radiation exposure limits are listed in the table below.

	<b>Frequency Range (MHz)</b>	<b>Power Density Limit (mW/cm<sup>2</sup>)</b>
<b>Limits for Occupational/Controlled Exposures</b>	0.3-3.0	100
	3.0-30	900/ Frequency <sup>2</sup>
	30-300	1.0
	300-1500	Frequency/300
	1500-100,000	5.0
<b>Limits for General Population/Uncontrolled Exposure</b>	0.3-1.34	100
	1.34-30	180/Frequency <sup>2</sup>
	30-300	0.2
	300-1500	Frequency/1500
	1500-100,000	1.0

For AMPS and CDMA Cell bands the limit for general population / uncontrolled exposure is calculated to be 0.56mW/cm<sup>2</sup>

For PCS band, the limit for general population / uncontrolled exposure is 1.0mW/cm<sup>2</sup>

**6.1 Calculations**

Since the G80050AUAL is not sold with an antenna the EIRP is calculated from the conducted power in the previous section of this report. That radiated power is then used to calculate the MPE at a 20 cm distance using the following formula:

$$\text{Maximum RF Exposure at 20cm} = (\text{EIRP in mW}) / (4\text{Pi}(20\text{cm})^2)$$

**Cell / AMPS Band:**

The maximum ERP for the cell band was 31.76dBm. To convert this value to EIRP 2.15 is added to get an EIRP value of 33.91dBm or 2460mW

Substituting this into the equation above, we get a Maximum RF Exposure (MPE) at 20cm of:

$$\begin{aligned} \text{MPE at 20cm} &= 2460\text{mW} / (4\text{Pi}(20\text{cm})^2) \\ \text{MPE at 20cm} &= 0.49\text{mW/cm}^2 \end{aligned}$$

**PCS Band:**

The maximum EIRP for the PCS band was 33dBm.

Substituting this into the equation above, we get a Maximum RF Exposure (MPE) at 20cm of:

$$\begin{aligned} \text{MPE at 20cm} &= 2000\text{mW} / (4\text{Pi}(20\text{cm})^2) \\ \text{MPE at 20cm} &= 0.397\text{mW/cm}^2 \end{aligned}$$

**6.2 Test Results**

The worst case MPE at 20cm of 0.51mW/cm<sup>2</sup> is less than the 0.5mW/cm<sup>2</sup> limit for general population/uncontrolled exposure shown in the table above for the cell band. For the PCS band, the worst case MPE at 20cm of 0.397mW/cm<sup>2</sup> is less than the 1 mW/cm<sup>2</sup> limit.

**7 EMISSION LIMITATIONS, OCCUPIED BANDWIDTH**

CFR 47 §2.1049: The occupied bandwidth is the frequency bandwidth such that, below its lower and above its upper frequency limits, the mean powers radiated are each equal to 0.5 percent of the total mean power radiated by a given emission.

RSS-129 (6.3.2)

**7.1 Test Procedure**

In both CDMA 800 and 1900 modes the antenna port of the EUT was connected to a spectrum analyzer using a calibrated coaxial cable and power divider. The EUT was placed into a call using base station simulator. The base station simulator was set to force the EUT to its maximum power setting. The occupied bandwidth function of the analyzer was used to automatically generate the occupied bandwidth plots below.

**7.2 Test Results**

The following is the occupied bandwidth data for the G80050AUAL .

Table 7-1: Occupied bandwidth measurements for CDMA modes

Mode	Channel	Resolution Bandwidth	Video Bandwidth	Sweep time	Measured Bandwidth (MHz)
CDMA800	1013	30 kHz	300 kHz	1.15s	1.28
CDMA800	384	30 kHz	300 kHz	1.15s	1.28
CDMA800	777	30 kHz	300 kHz	1.15s	1.28
CDMA1900	25	30 kHz	300 kHz	1.15s	1.28
CDMA1900	600	30 kHz	300 kHz	1.15s	1.28
CDMA1900	1175	30 kHz	300 kHz	1.15s	1.28

Figure 7-1: Occupied Bandwidth – Cell Channel 1013

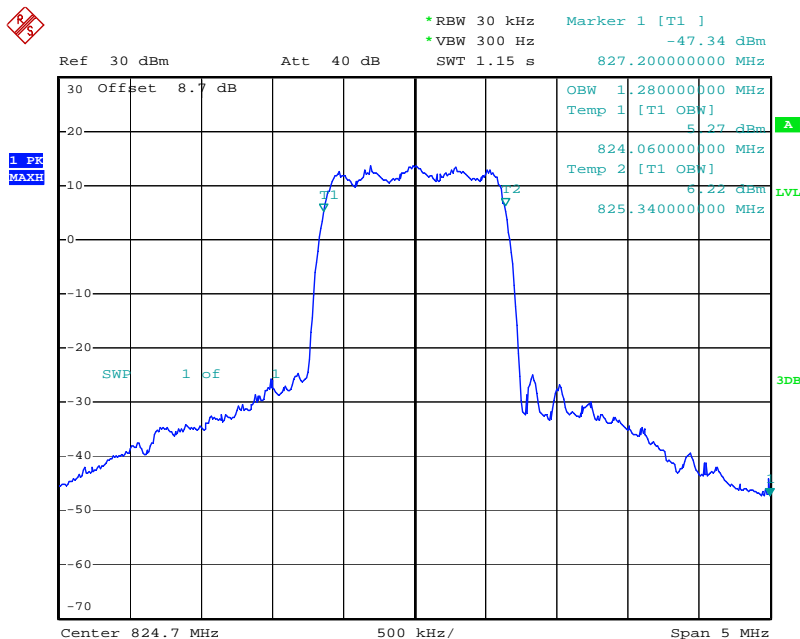

Date: 16.SEP.2007 19:21:57

Figure 7-2: Occupied Bandwidth – Cell Channel 384

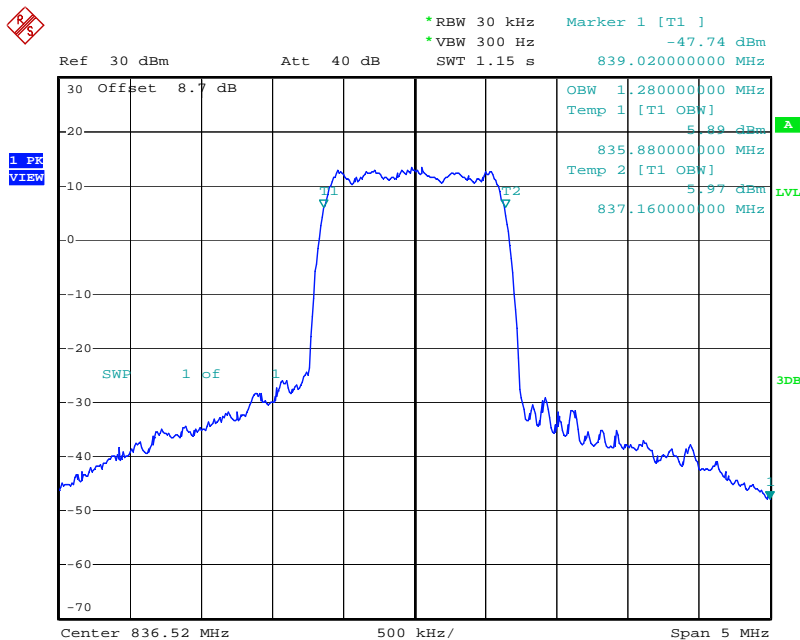

Date: 16.SEP.2007 19:21:19

Figure 7-3: Occupied Bandwidth – Cell Channel 777

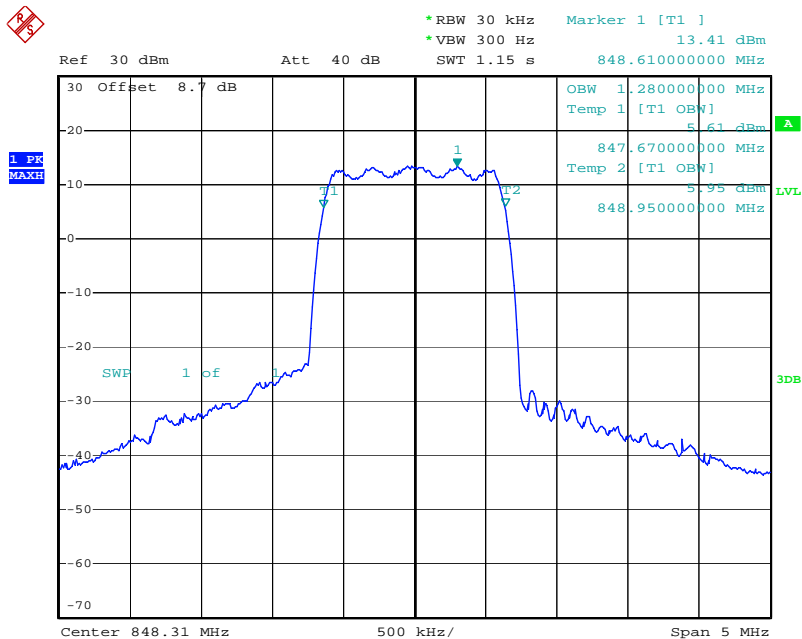

Date: 16.SEP.2007 19:19:45

Figure 7-4: Occupied Bandwidth – PCS Channel 25

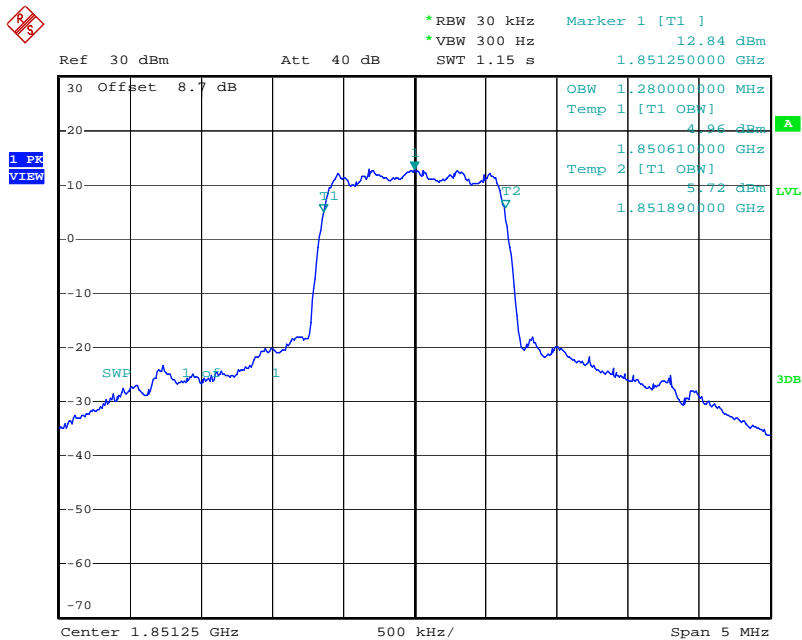

Date: 16.SEP.2007 19:24:31

Figure 7-5: Occupied Bandwidth – PCS Channel 600

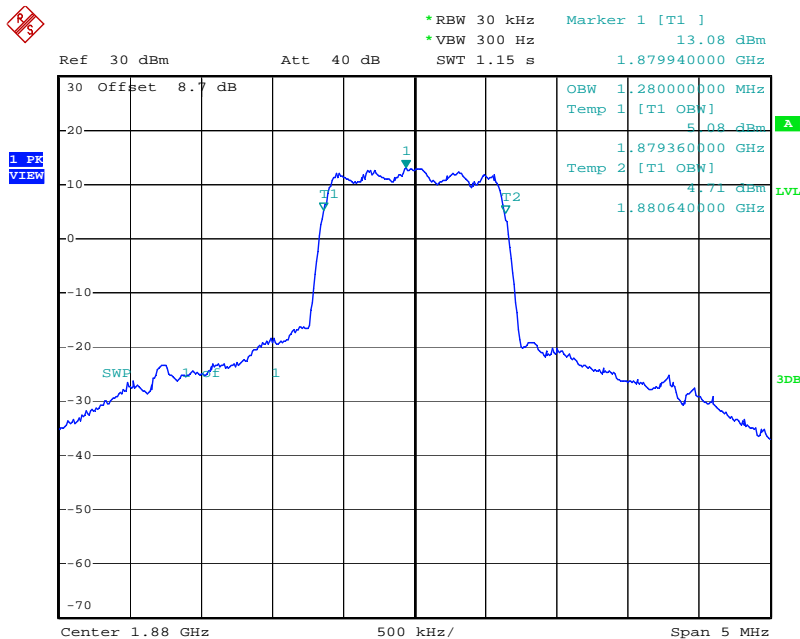

Date: 16.SEP.2007 19:25:43

Figure 7-6: Occupied Bandwidth – PCS Channel 1175

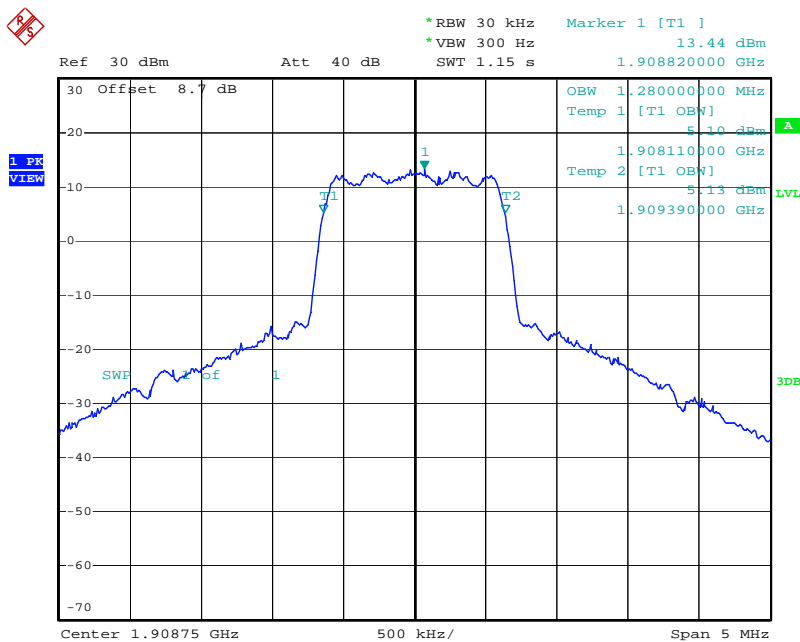

Date: 16.SEP.2007 19:27:06



## **8 OUT OF BAND EMISSION AT ANTENNA TERMINALS**

FCC §2.1049, FCC §2.1051, §22.917(a), FCC §24.238(a)

RSS-129 §6.3, §7.2.2, §8.1.1, §9.3, §9.4 §10

RSS-133 §6.3

Out of Band Emissions: The power of any emission outside of the authorized operating frequency ranges must be attenuated below the transmitting power (P) by a factor of at least  $43 + 10 \log(P)$  dB.

### **8.1 Test Procedure**

Compliance with these rules is based on the use of measurement instrumentation employing a resolution bandwidth of 100 kHz or greater for the Cellular band and 1 MHz or greater in the PCS band. In the 1 MHz bands immediately outside and adjacent to the frequency block a resolution bandwidth of at least one percent of the emission bandwidth of the fundamental emission of the transmitter may be employed. A narrower resolution bandwidth is permitted in all cases to improve measurement accuracy provided the measured power is integrated over the full required measurement bandwidth (i.e. 100 kHz or 1 percent of emission bandwidth, as specified). The emission bandwidth is defined as the width of the signal between two points, one below the carrier center frequency and one above the carrier center frequency, outside of which all emissions are attenuated at least 26 dB below the transmitter power.

The RF output of the transceiver was connected to a spectrum analyzer through appropriate attenuation. The Base Station Simulator was set to force the EUT to its maximum power setting. The resolution bandwidth of the spectrum analyzer was set at 1 MHz. Sufficient scans were taken to show the out of band Emissions if any up to 10th harmonic.

**8.2 Test Results**

The G80050AUAL met the out of band emission at antenna terminal requirements.

Table 8-1: Summary of test result locations

Location	Mode (Band)	Channel	Description
Figure 8-1	AMPS	381, 799, 991	Conducted spurious emissions, 30MHz to 20 GHz
Figure 8-2	AMPS	381, 799, 991	Zoom Graph of the Carrier Frequencies
Figure 8-3	CDMA Cell	384, 777, 1013	Conducted spurious emissions, 30MHz to 20 GHz
Figure 8-4	CDMA Cell	384, 777, 1013	Zoom Graph of the Carrier Frequencies
Figure 8-5	CDMA PCS	25, 600, 1175	Conducted spurious emissions, 30MHz to 20 GHz
Figure 8-6	CDMA PCS	25, 600, 1175	Zoom Graph of the Carrier Frequencies
	CDMA Cell	1013	Emissions within 1 MHz of band edge
Figure 8-8	CDMA Cell	777	Emissions within 1 MHz of band edge
Figure 8-9	CDMA PCS	25	Emissions within 1 MHz of band edge
Figure 8-10	CDMA PCS	1175	Emissions within 1 MHz of band edge
Figure 8-11	AMPS	384	Mean Power of Emissions in Base Station Frequency Band –Voice Mode
Figure 8-12	AMPS	799	Mean Power of Emissions in Base Station Frequency Band –Voice Mode
Figure 8-13	AMPS	991	Mean Power of Emissions in Base Station Frequency Band –Voice Mode
Figure 8-14	AMPS	384	Mean Power of Emissions in Base Station Frequency Band – Wide Band Data Mode
Figure 8-15	AMPS	799	Mean Power of Emissions in Base Station Frequency Band – Wide Band Data Mode
Figure 8-16	AMPS	991	Mean Power of Emissions in Base Station Frequency Band – Wide Band Data Mode
Figure 8-17	CDMA	1013	Mean Power of Emissions in Base Station Frequency Band
Figure 8-18	CDMA	384	Mean Power of Emissions in Base Station Frequency Band
Figure 8-19	CDMA	1175	Mean Power of Emissions in Base Station Frequency Band
Figure 8-20	CDMA	1013	Mobile Station Spurious Emissions When Transmitting
Figure 8-21	CDMA	384	Mobile Station Spurious Emissions When Transmitting
Figure 8-22	CDMA	1175	Mobile Station Spurious Emissions When Transmitting
Figure 8-23	CDMA	1013	Minimum Controlled Output Power
Figure 8-24	CDMA	384	Minimum Controlled Output Power
Figure 8-25	CDMA	1175	Minimum Controlled Output Power
Figure 8-26	CDMA	-	Standby Output Power Measurement

Table 8-2: Spurious Emissions at Antenna Terminals

EUT Mode	TX Channel	Spurious Emission Frequency (GHz)	Device Reading (dBm)	Cable Loss (dB)	Conducted Power (dBm)	Limit (dBm)	Margin (dB)
AMPS	799	1.697	-25.52	8.7	-16.82	-13	-3.82
AMPS	384	1.673	-32.97	8.7	-24.27	-13	-11.27
AMPS	991	1.648	-33.27	8.7	-24.57	-13	-11.57
CELL	1013	1.649	-39.30	8.7	-30.6	-13	-17.6
CELL	384	1.673	-40.40	8.7	-31.7	-13	-18.7
CELL	777	1.696	-32.70	8.7	-24	-13	-11
PCS	25	3.701	-47.20	9	-38.2	-13	-25.2
PCS	600	3.761	-47.50	9	-38.5	-13	-25.5
PCS	1175	3.815	-30.90	9	-21.9	-13	-8.9

Figure 8-1: Out of band emissions at antenna terminals – AMPS Channel 384, 799, and 991

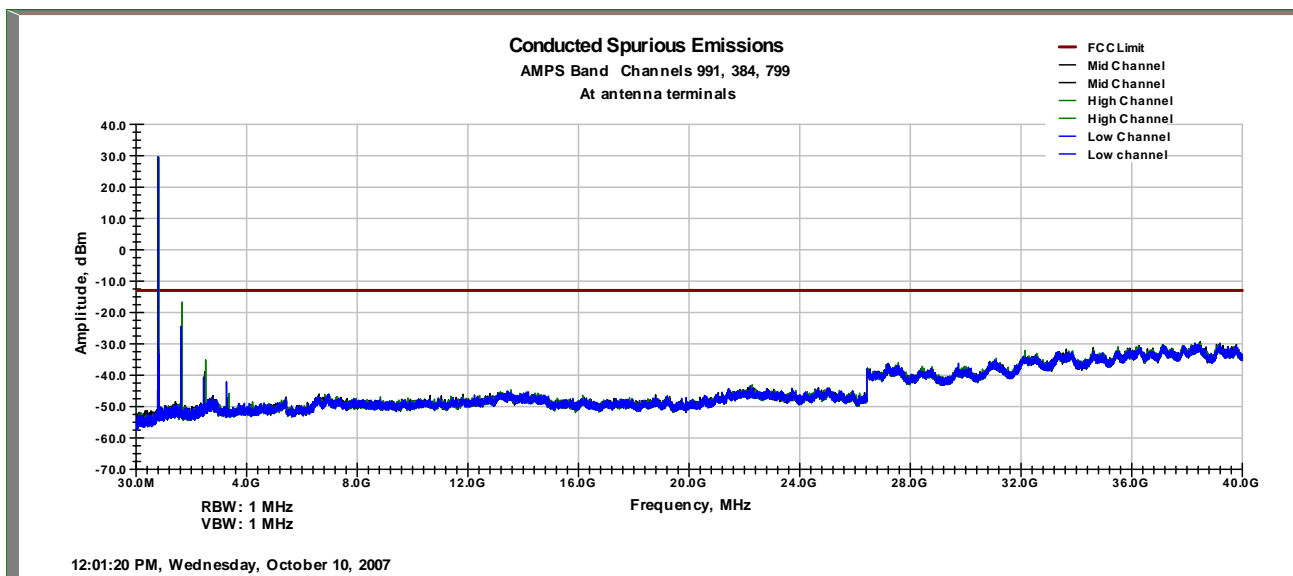

Figure 8-2: Out of band emissions at antenna terminals – AMPS Channel 384, 799, and 991 (Zoomed Around Carrier Frequencies)

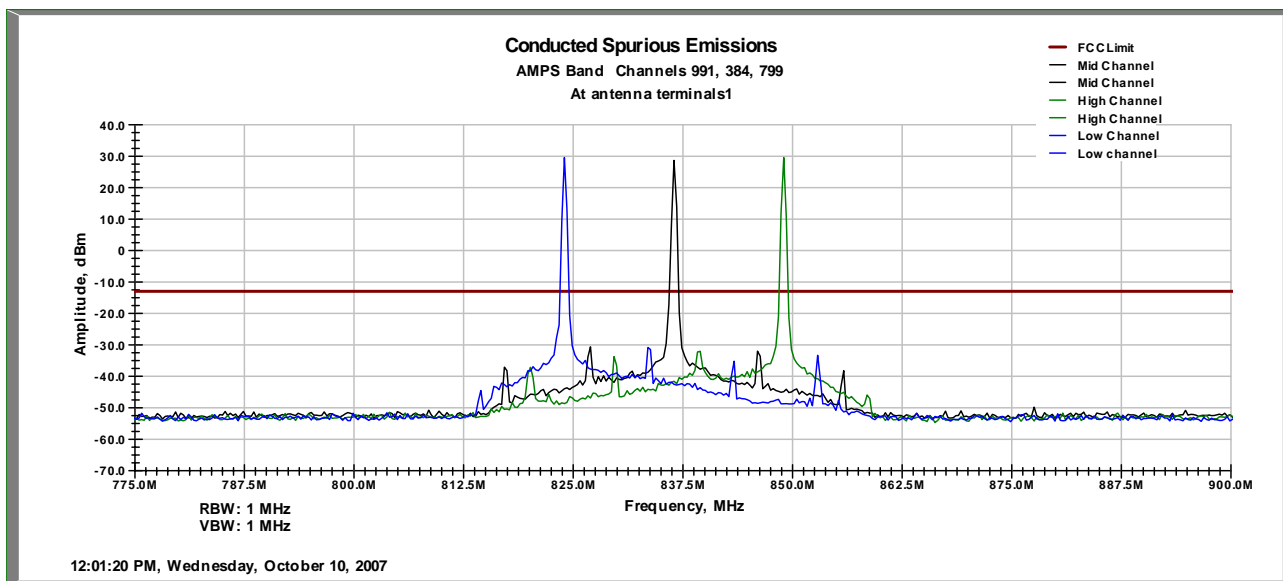

Figure 8-3: Out of band emissions at antenna terminals – CDMA 800 Channel 384, 777, and 1013

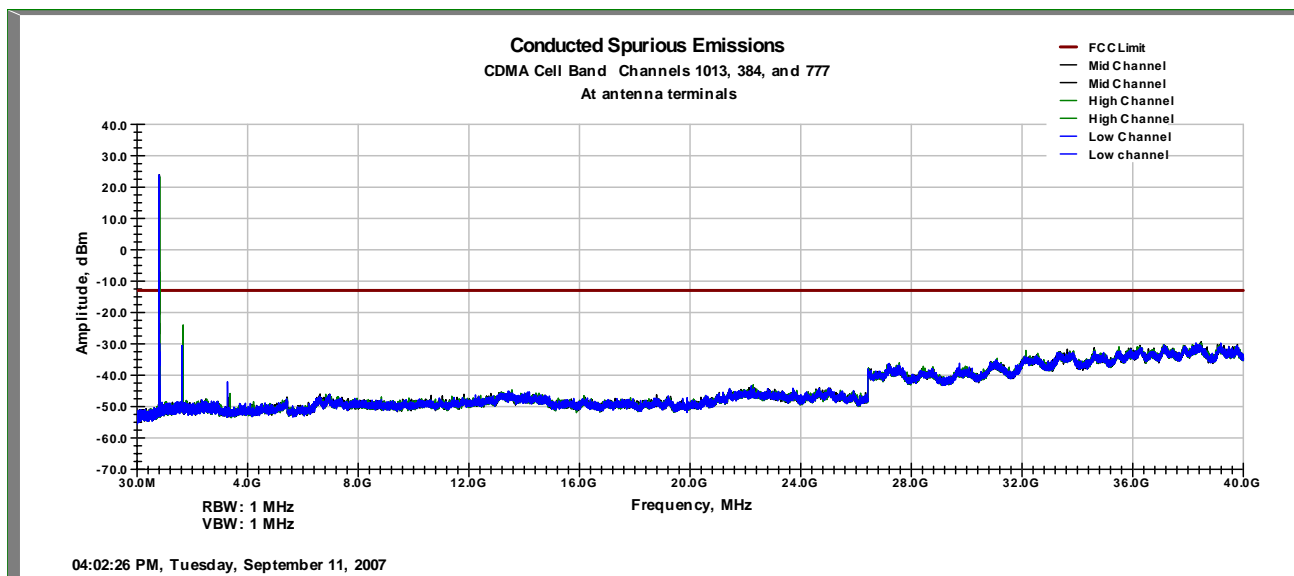

Figure 8-4: Out of band emissions at antenna terminals – CDMA 800 Channel 384, 777, and 1013 (Zoomed Around Carrier Frequencies)

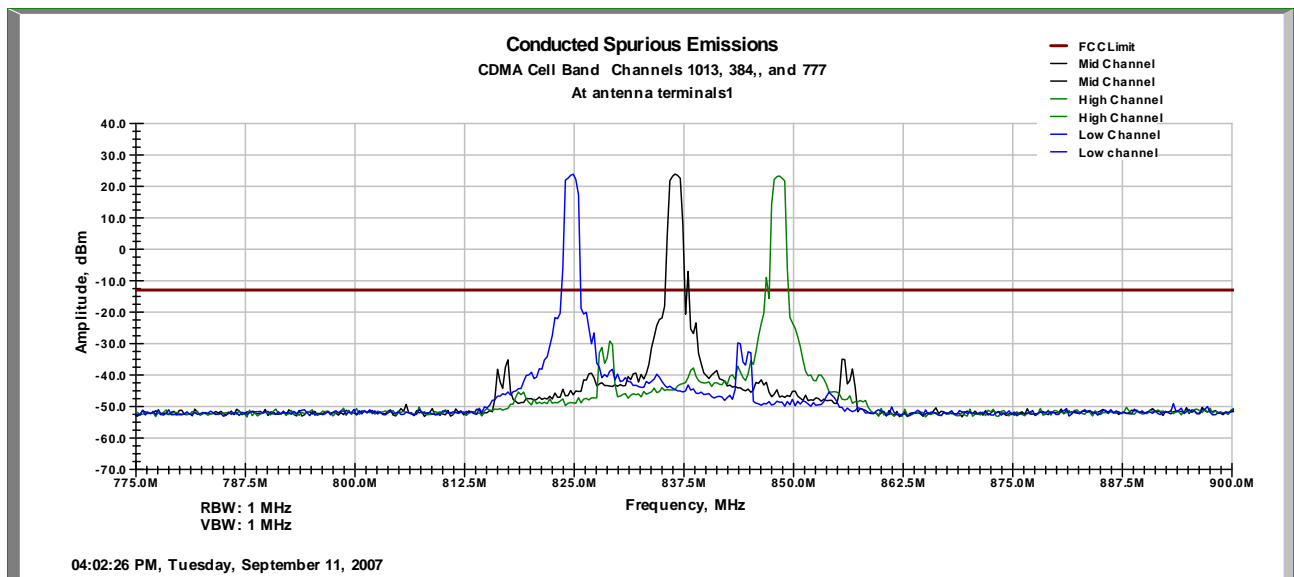

Figure 8-5: Out of band emissions at antenna terminals – CDMA1900 Channel 25, 600, 1175

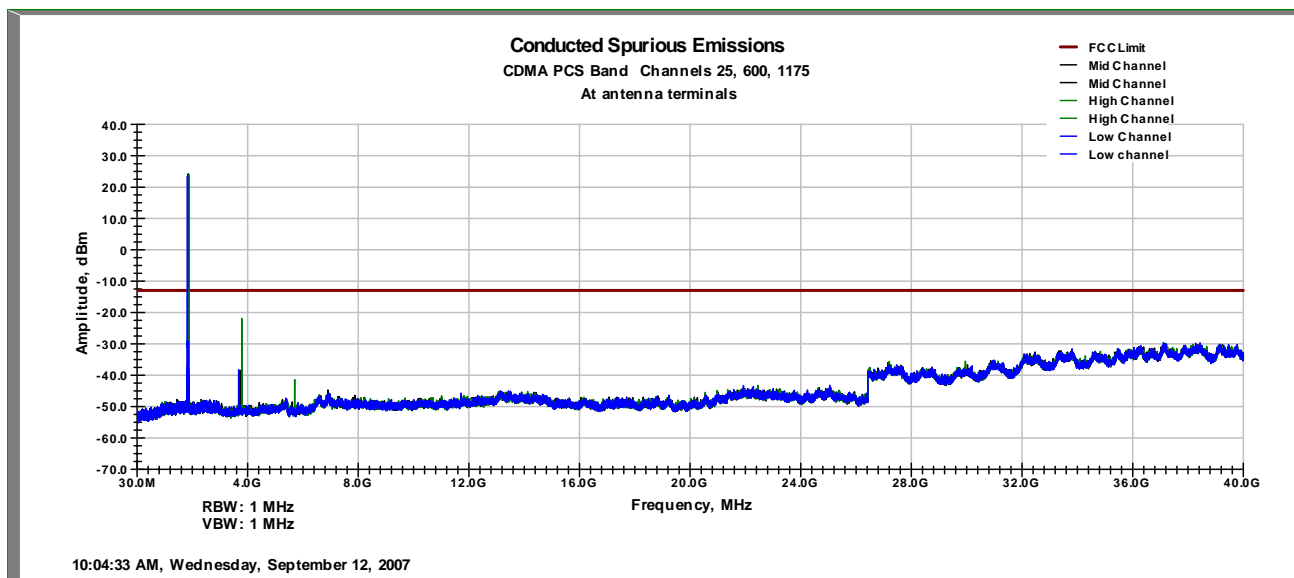
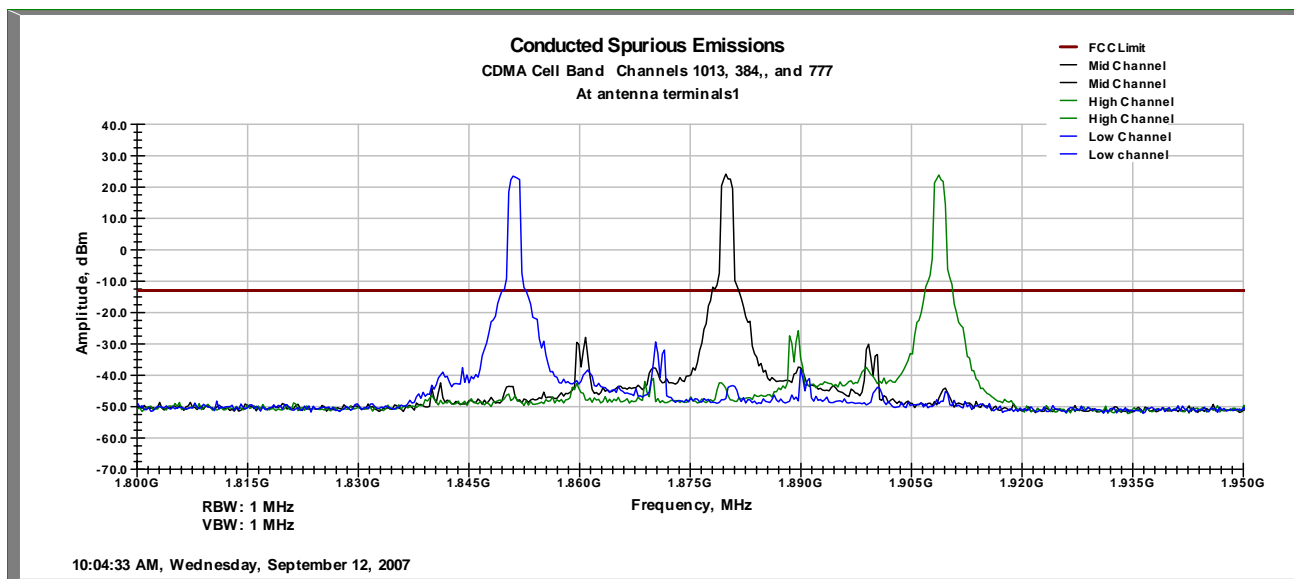

Figure 8-6: Out of band emissions at antenna terminals – CDMA1900 Channel 25, 600, 1175 (Zoomed In on Carrier Frequencies)



Evaluation For: Continental Automotive Systems  
 Model No: G80050AUAL

FCC ID: LHJGEN80CNT  
 ICID:2807E-GEN80CNT

Figure 8-7: Emissions within 1 MHz of band edge, CDMA 800 Channel 1013

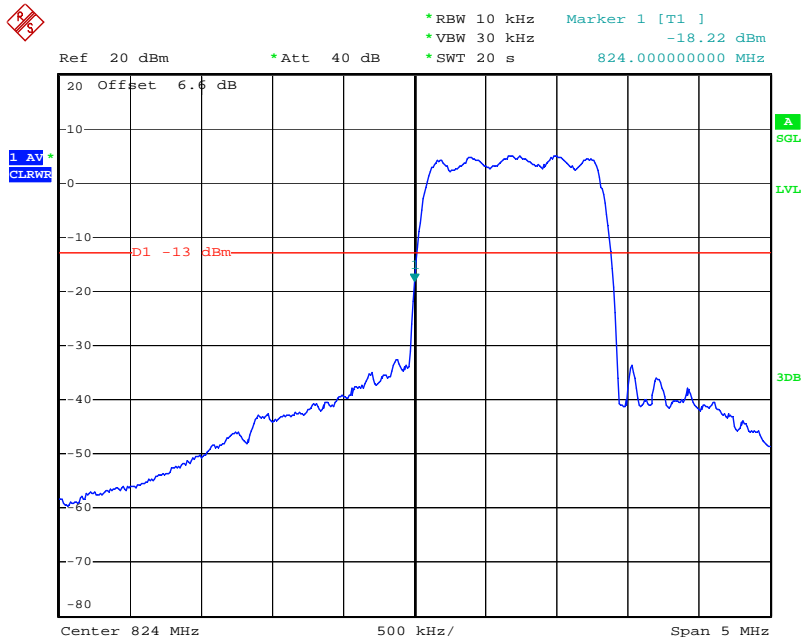

Date: 17.SEP.2007 16:47:19

Figure 8-8: Emissions within 1 MHz of band edge, CDMA 800 Channel 777

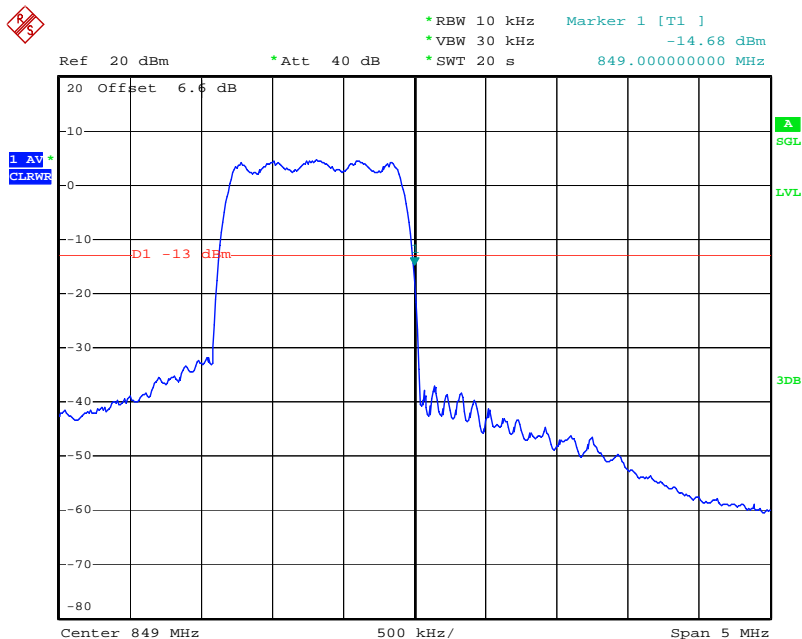

Date: 17.SEP.2007 16:48:31

Figure 8-9: Emissions within 1 MHz of band edge, CDMA 1900 Channel 25

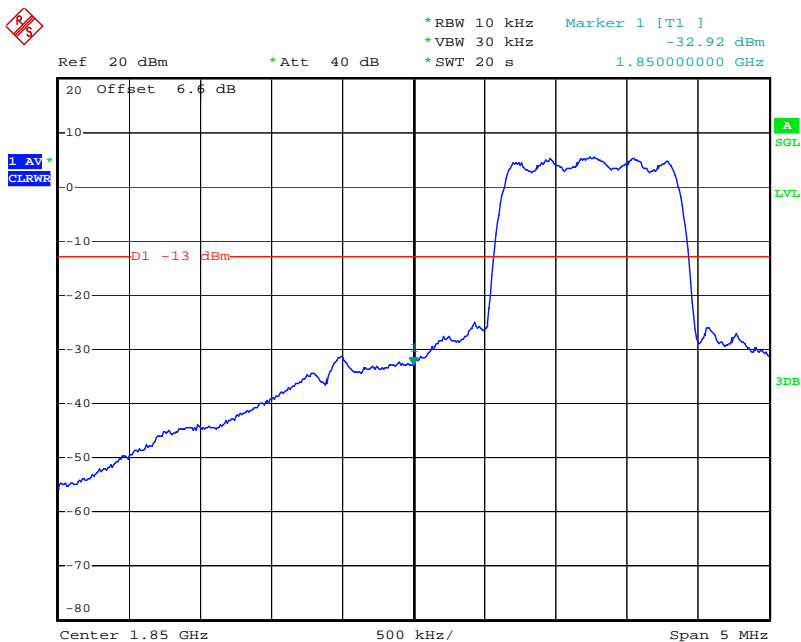

Date: 17.SEP.2007 16:50:42

Figure 8-10: Emissions within 1 MHz of band edge, CDMA 1900 Channel 1175

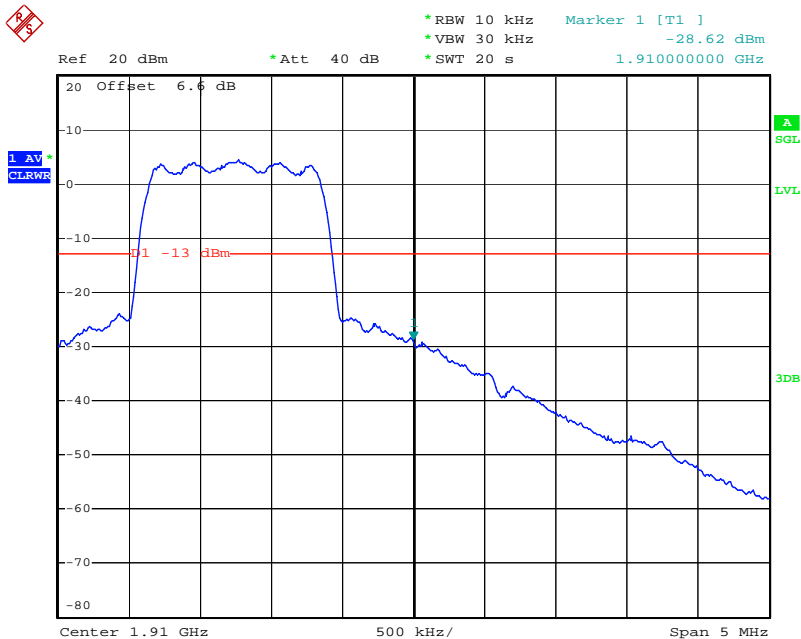

Date: 17.SEP.2007 16:51:42



Evaluation For: Continental Automotive Systems  
 Model No: G80050AUAL

FCC ID: LHJGEN80CNT  
 ICID:2807E-GEN80CNT

Figure 8-11: Mean Power of Emissions in Base Station Band (AMPS, Voice Mode) – Low Channel

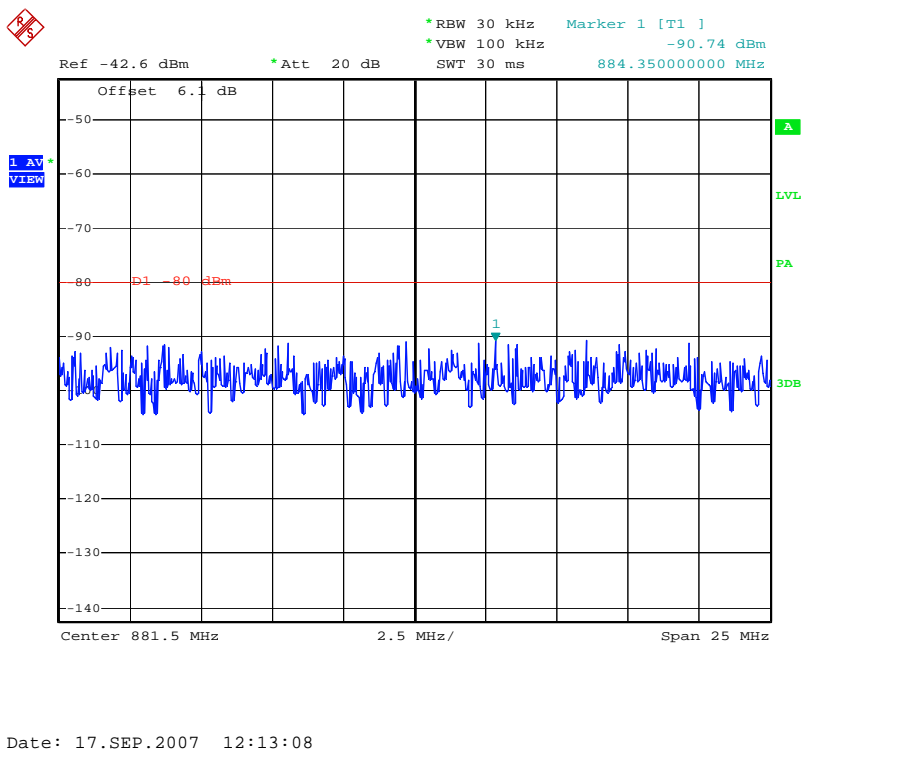

Figure 8-12: Mean Power of Emissions in Base Station Band (AMPS, Voice Mode) – Mid Channel

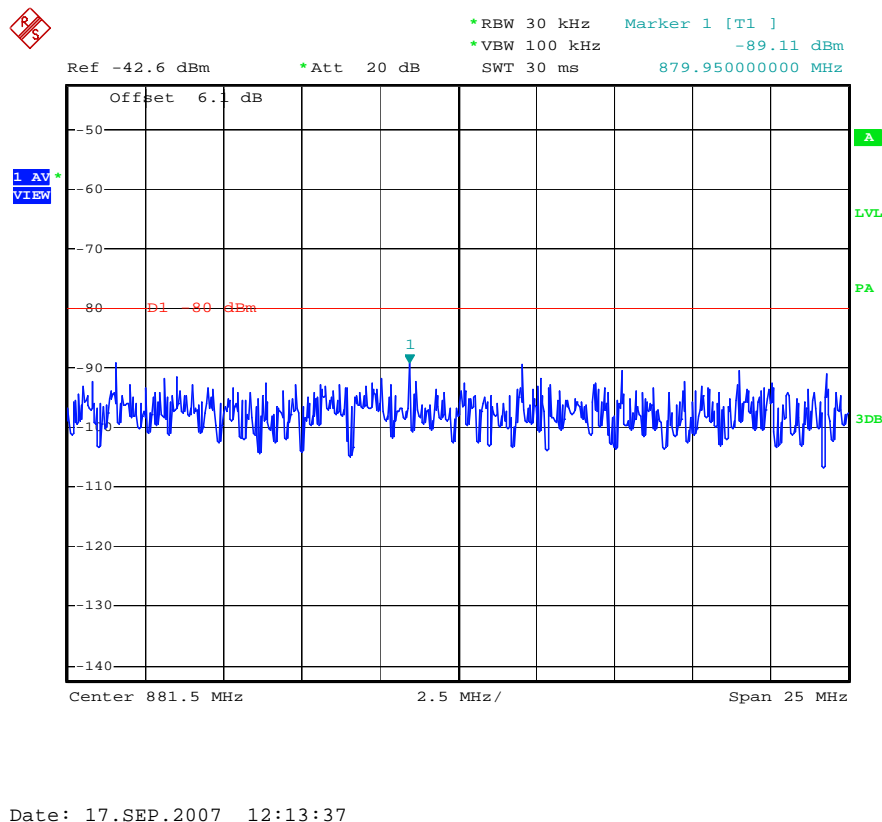
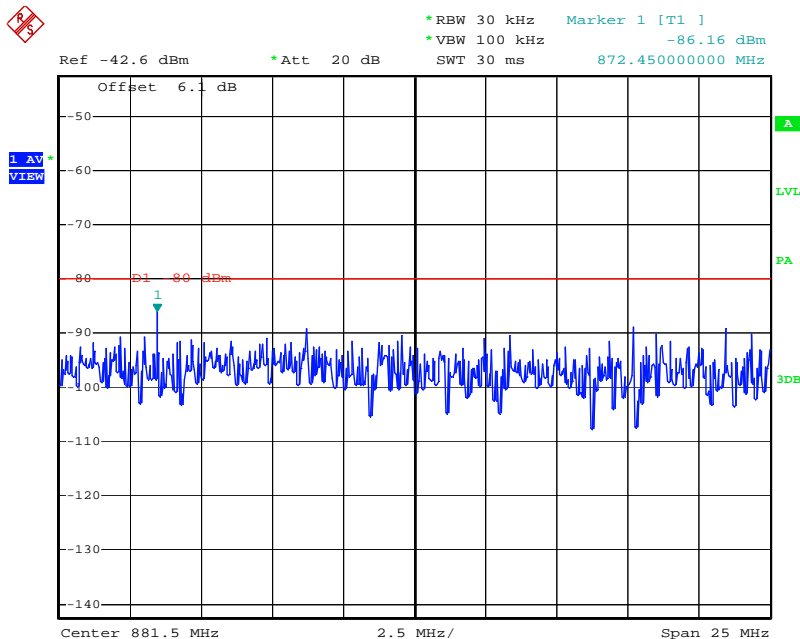
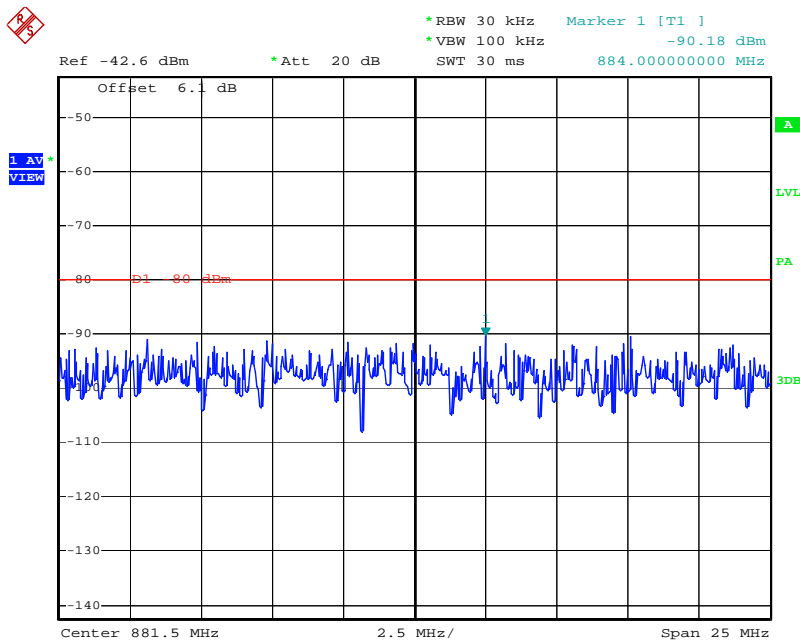

Figure 8-13: Mean Power of Emissions in Base Station Band (AMPS, Voice Mode) – High Channel



Date: 17.SEP.2007 12:14:13

Figure 8-14: Mean Power of Emissions in Base Station Band (AMPS, Wide Band Data Mode) – Low Channel



Date: 17.SEP.2007 12:15:34

Figure 8-15: Mean Power of Emissions in Base Station Band (AMPS, Wide Band Data Mode) – Mid Channel

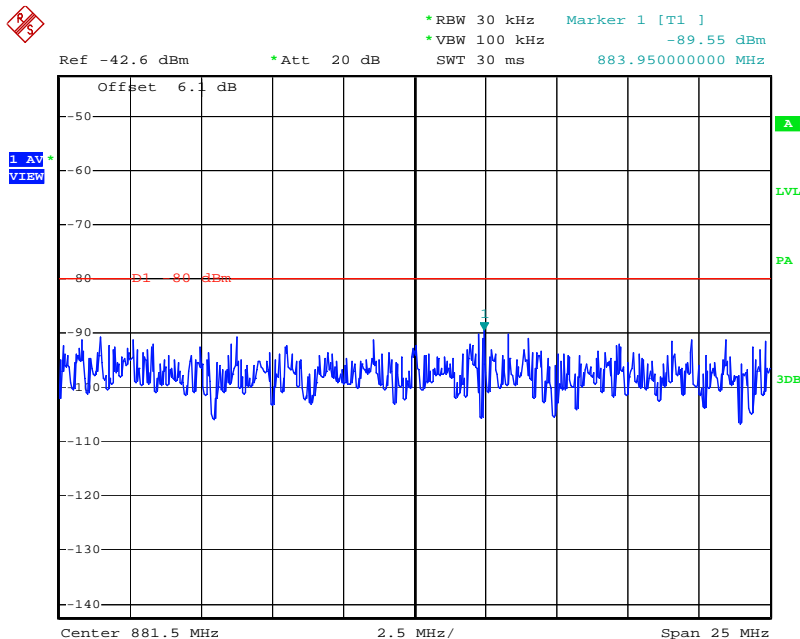

Date: 17.SEP.2007 12:17:28

Figure 8-16: Mean Power of Emissions in Base Station Band (AMPS, Wide Band Data Mode) – High Channel

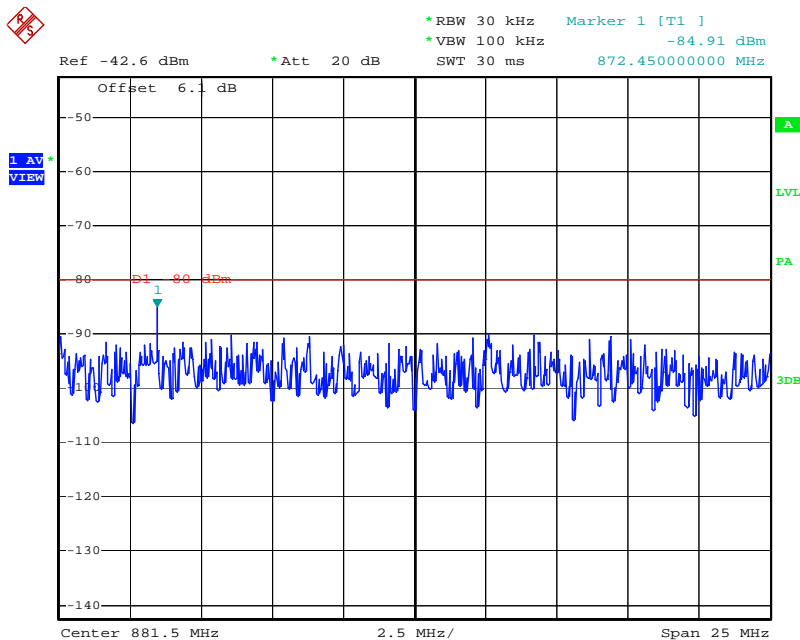

Date: 17.SEP.2007 12:17:56

Figure 8-17: Mean Power of Emissions in Base Station Band (CDMA Mode) – Low Channel

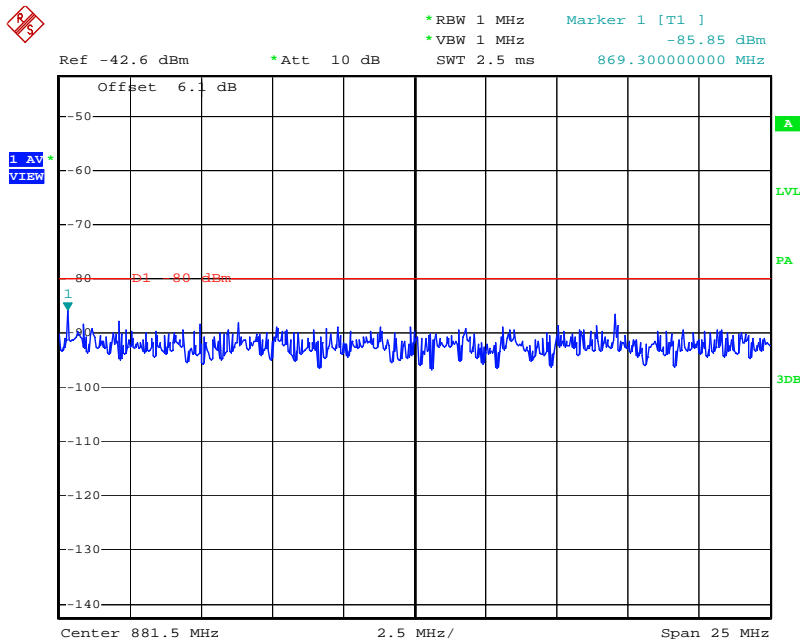

Date: 17.SEP.2007 14:07:57

Figure 8-18: Mean Power of Emissions in Base Station Band (CDMA Mode) – Mid Channel

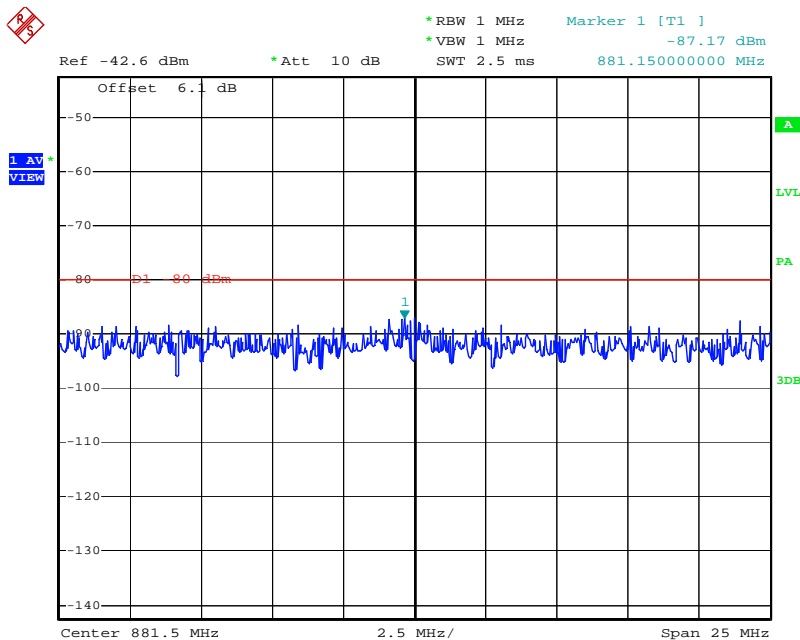

Date: 17.SEP.2007 14:08:30

Figure 8-19: Mean Power of Emissions in Base Station Band (CDMA Mode) – High Channel

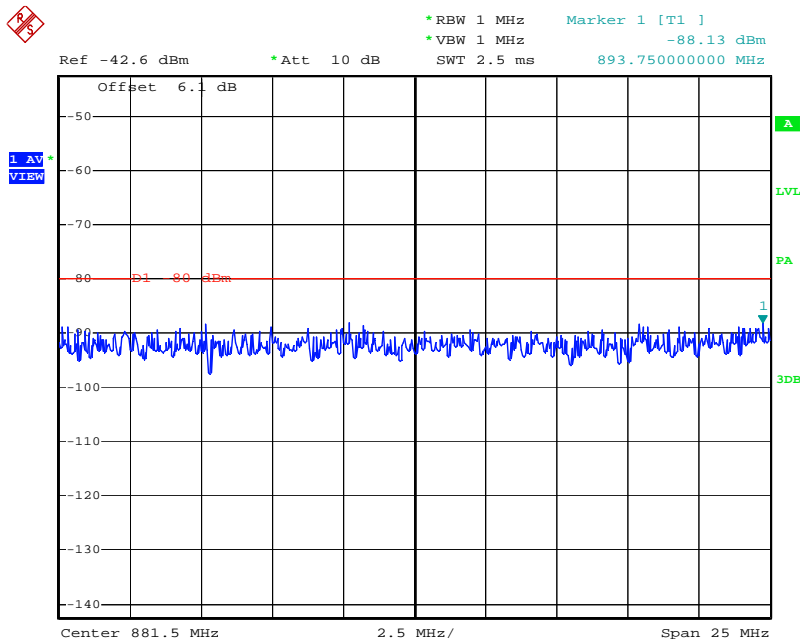

Date: 17.SEP.2007 14:09:14

Figure 8-20: Mobile Station Spurious Emissions When Transmitting (CDMA Mode) – Low Channel

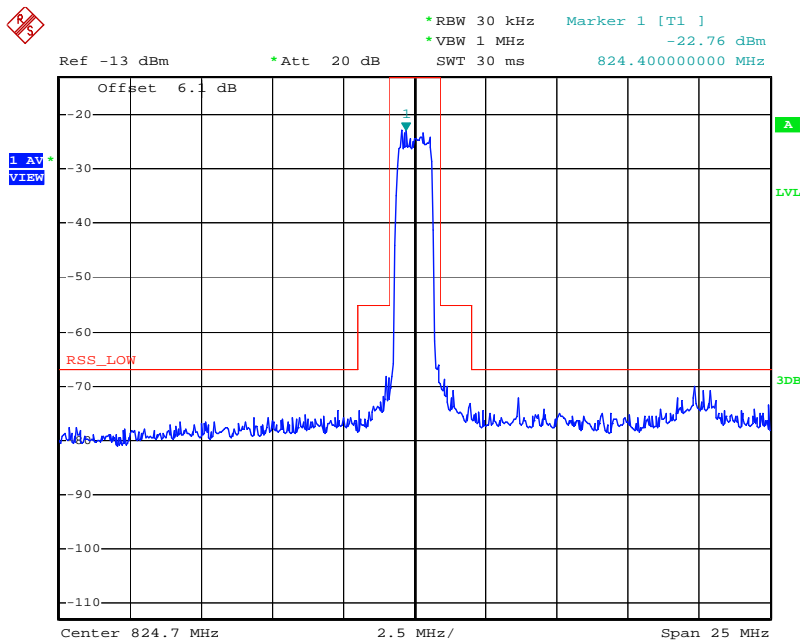

Date: 17.SEP.2007 14:38:55

Figure 8-21: Mobile Station Spurious Emissions When Transmitting (CDMA Mode) – Mid Channel

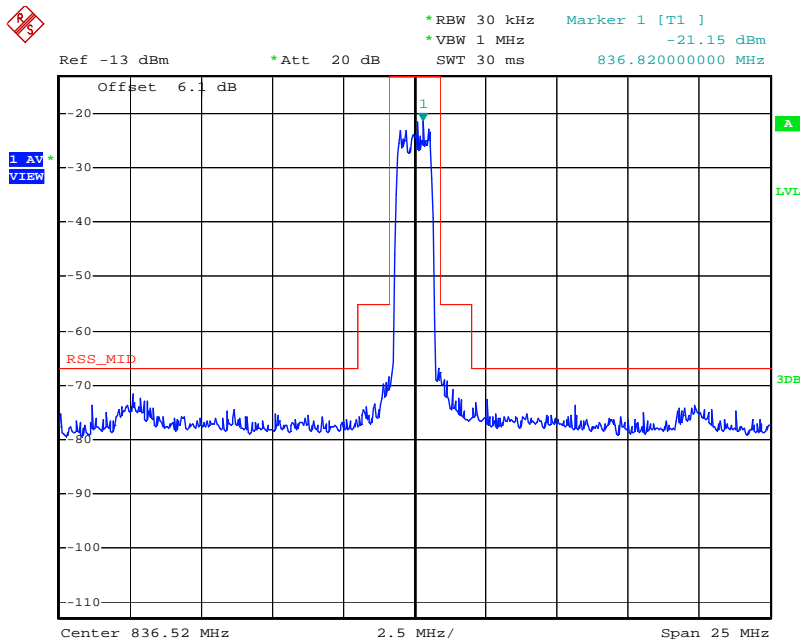

Date: 17.SEP.2007 14:40:08

Figure 8-22: Mobile Station Spurious Emissions When Transmitting (CDMA Mode) – High Channel

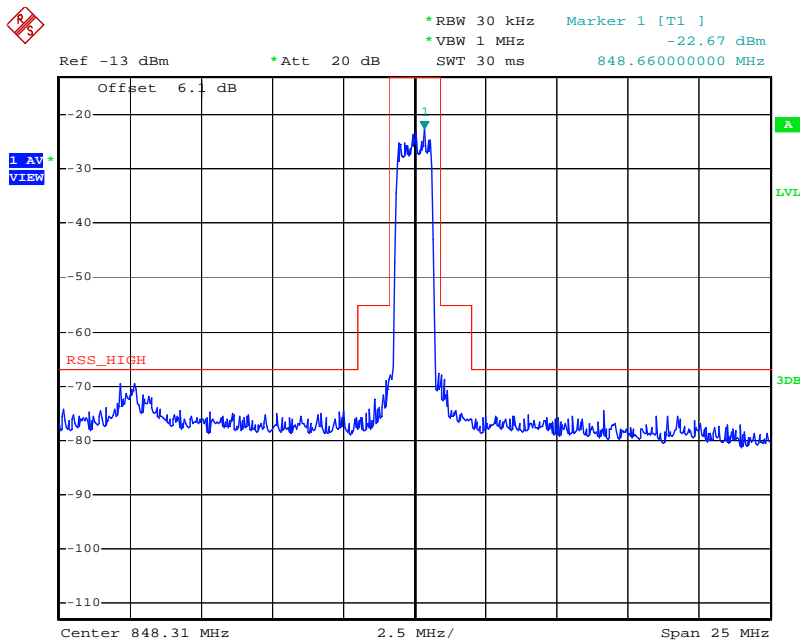

Date: 17.SEP.2007 14:42:16

Figure 8-23: Mobile Station Minimum Controlled Output Power (CDMA Mode) – Low Channel

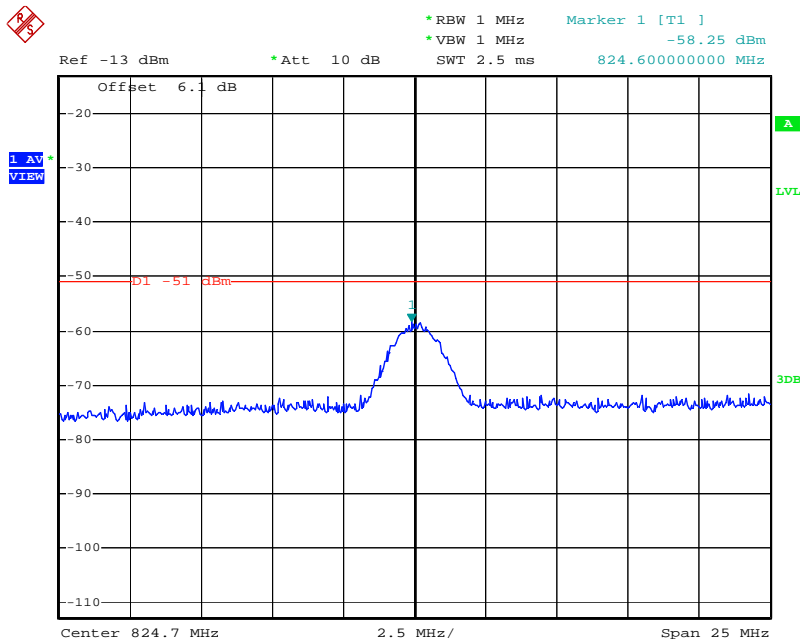

Date: 17.SEP.2007 14:58:02

Figure 8-24: Mobile Station Minimum Controlled Output Power (CDMA Mode) – Mid Channel

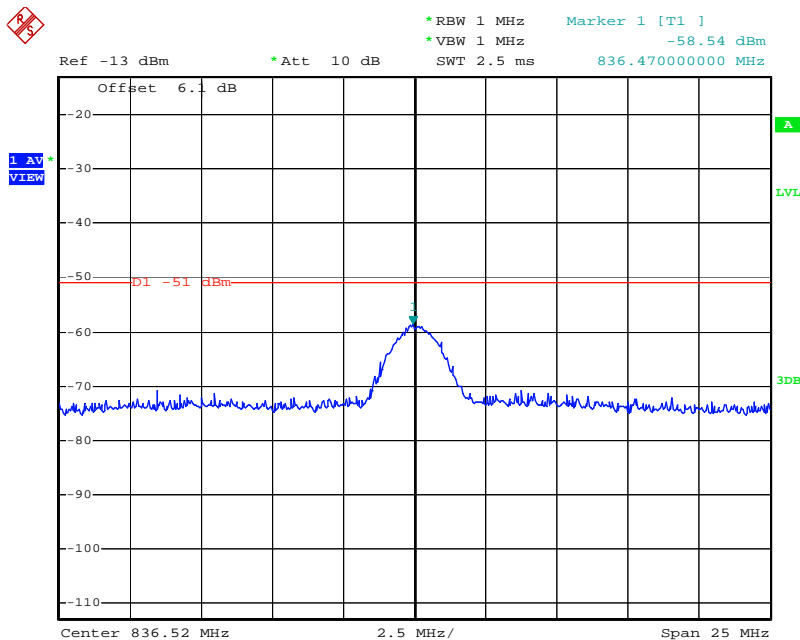

Date: 17.SEP.2007 14:59:13

Figure 8-25: Mobile Station Minimum Controlled Output Power (CDMA Mode) – High Channel

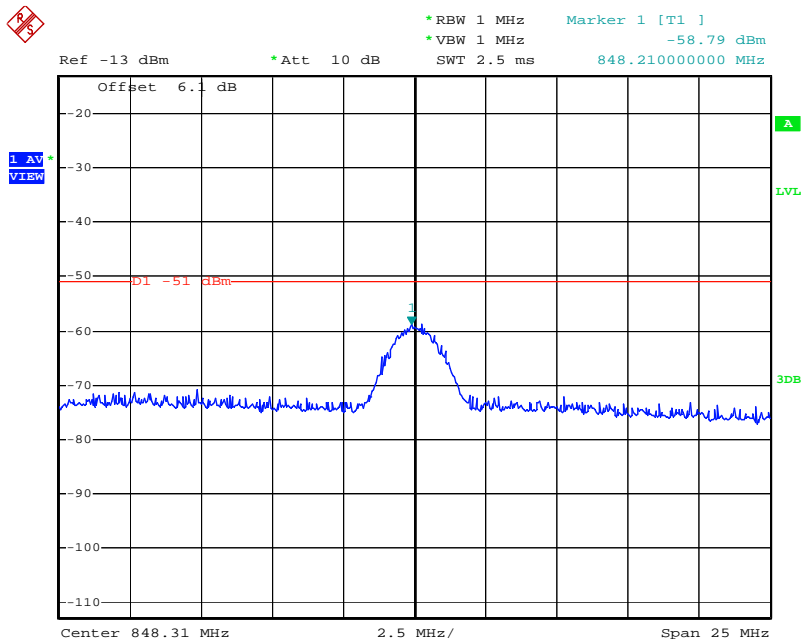

Date: 17.SEP.2007 14:59:51

Figure 8-26: Mobile Station Standby Output Power (CDMA Mode)

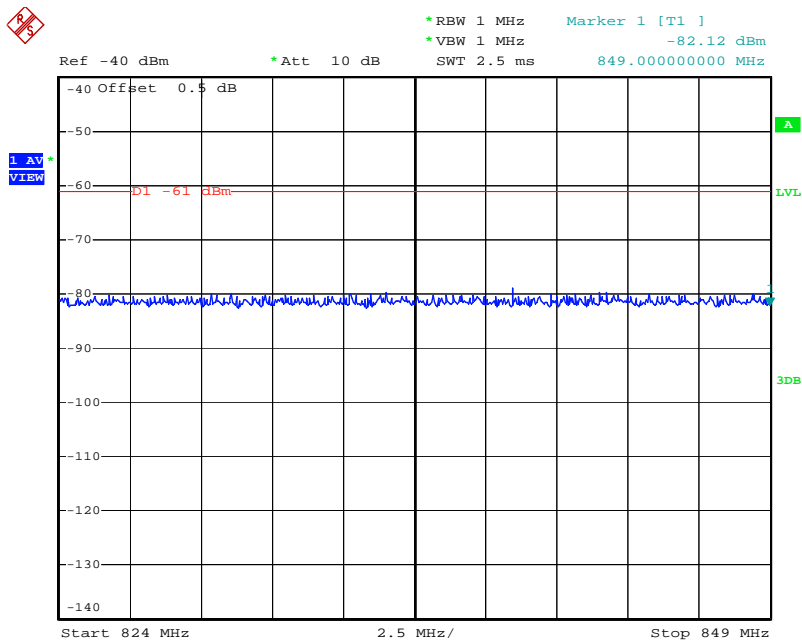

Date: 17.SEP.2007 15:04:36



**9 RADIATED SPURIOUS EMISSIONS**

FCC §2.1053

RSS-129 §8.1

**9.1 Test Procedure**

The EUT was placed on a non-conductive turntable. The measurement antenna was placed at a distance of 3 meters from the EUT. The Base Station Simulator was set to force the EUT to its maximum power setting. During the tests, the antenna height and EUT azimuth were varied in order to identify the maximum level of emissions from the EUT.

The frequency range up to tenth harmonic was investigated for each of three fundamental frequencies (low, middle, and high channels) in each operating band. Once spurious emissions were identified, the power of the emission was determined using the substitution method described in TIA-603-B section 2.2.12 (Radiated Spurious Emissions).

The spurious emissions attenuation was calculated as the difference between radiated power at the fundamental frequency and at the spurious emissions frequency.

**9.2 Test Results**

The G80050AUAL met the field strength of spurious radiation requirements of FCC §2.1053. See Figure 9-1 through Figure 9-9 for the graphical test data.

Table 9-1: Radiated Spurious Emissions

EUT Mode	TX Channel	Polarity	Spurious Emission Frequency	Device Reading (dBuV)	Signal Generator Output (dBm)	Cable Loss (dB)	Tx Antenna Gain (dBi)	Tx Antenna Gain (dBd)	Radiated Power (dBm)	Limit (dBm)	Margin (dB)
AMPS	799	V	3.3959	49.8	-52.2	5.4	9.2	7.06	-50.54	-13	-37.54
AMPS	799	V	1.6979	36.9	-33.4	3.8	8.4	6.26	-30.94	-13	-17.94
AMPS	384	V	3.346	47.5	-54.7	5.3	5.4	3.26	-56.74	-13	-43.74
AMPS	384	V	1.672	32.8	-35.6	3.8	8.4	6.26	-33.14	-13	-20.14
AMPS	991	V	3.296	49.1	-52.5	5.2	5.4	3.26	-54.44	-13	-41.44
AMPS	991	V	1.648	30.1	-39.5	3.8	8.4	6.26	-37.04	-13	-24.04
CDMA Cell	777	V	1.696	29.4	-40.7	3.8	8.4	6.26	-38.24	-13	-25.24
CDMA Cell	384	V	1.672	26.7	-41.4	3.8	8.4	6.26	-38.94	-13	-25.94
CDMA Cell	1013	V	1.649	23.8	-44.5	3.8	8.4	6.26	-42.04	-13	-29.04
CDMA PCS	25	V	3.7025	51.3	-47.1	5.6	10.1	7.96	-44.74	-13	-31.74
CDMA PCS	600	V	3.76	49.2	-49.4	5.7	10.2	8.06	-47.04	-13	-34.04
CDMA PCS	1175	V	3.816	56.8	-42.3	6	10.3	8.16	-40.14	-13	-27.14

Figure 9-1: Field Strength of Spurious Radiation (30 MHz – 20 GHz), AMPS Channel 991

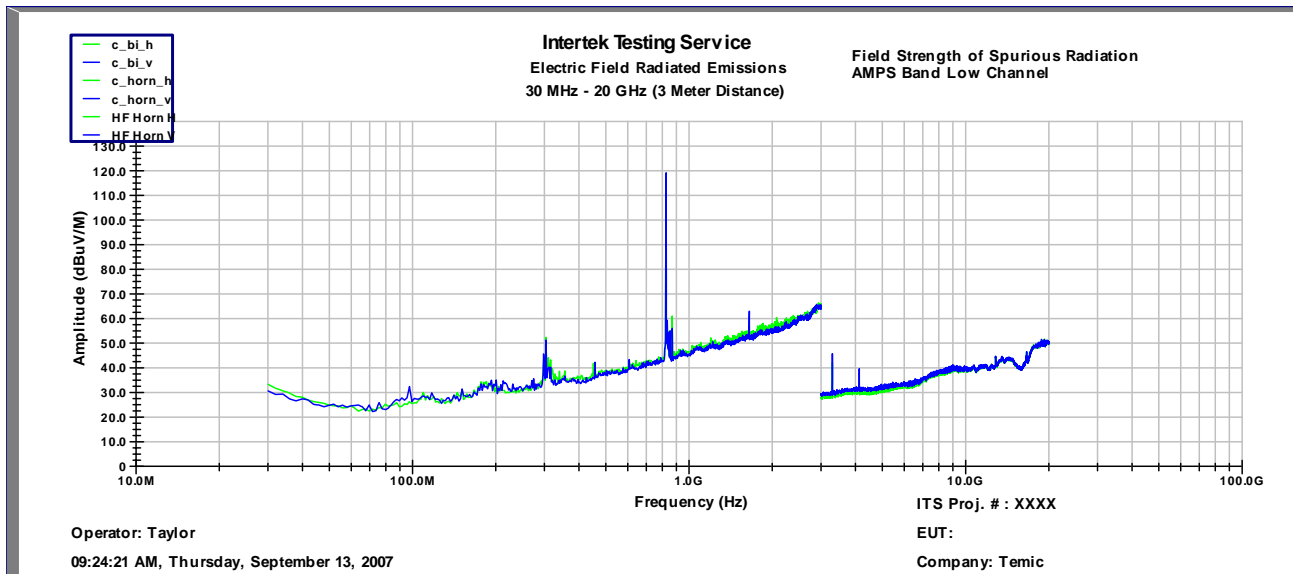

Figure 9-2: Field Strength of Spurious Radiation (30 MHz – 20 GHz), AMPS Channel 384

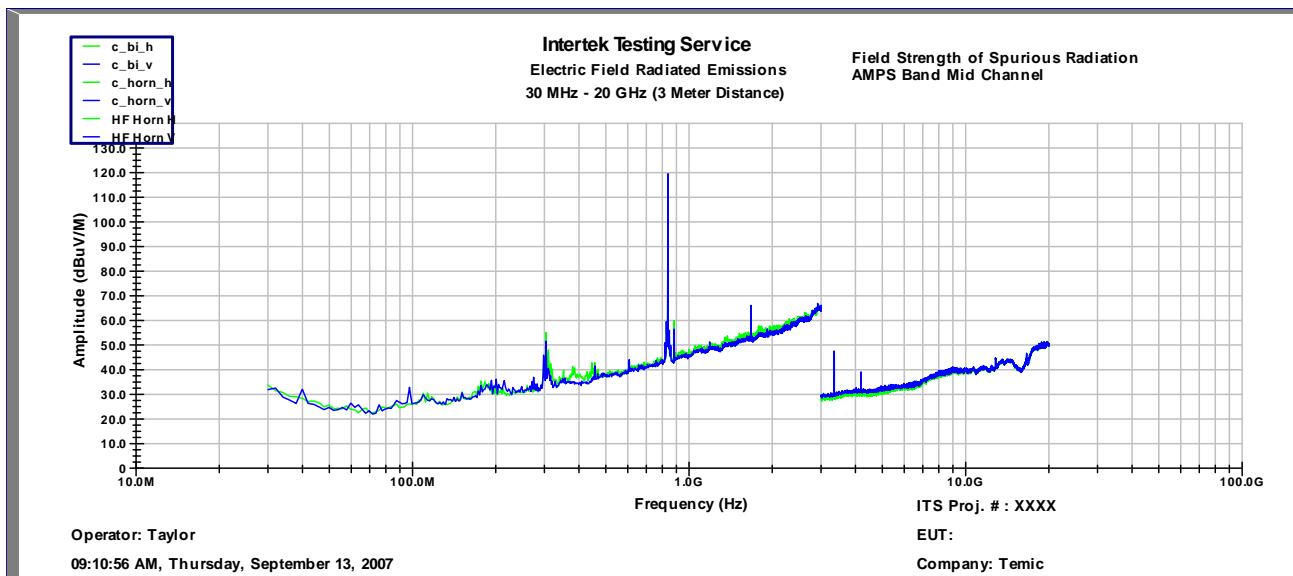

Figure 9-3: Field Strength of Spurious Radiation (30 MHz – 20 GHz), AMPS Channel 799

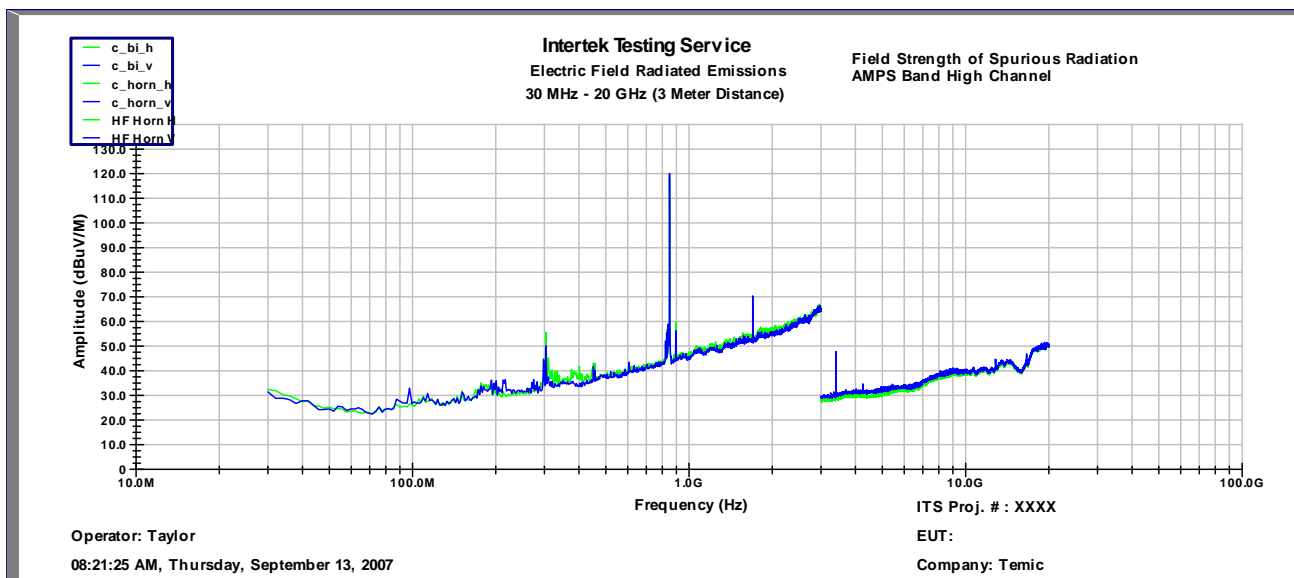

Figure 9-4: Field Strength of Spurious Radiation (30 MHz – 20 GHz), CDMA Cell Channel 1013

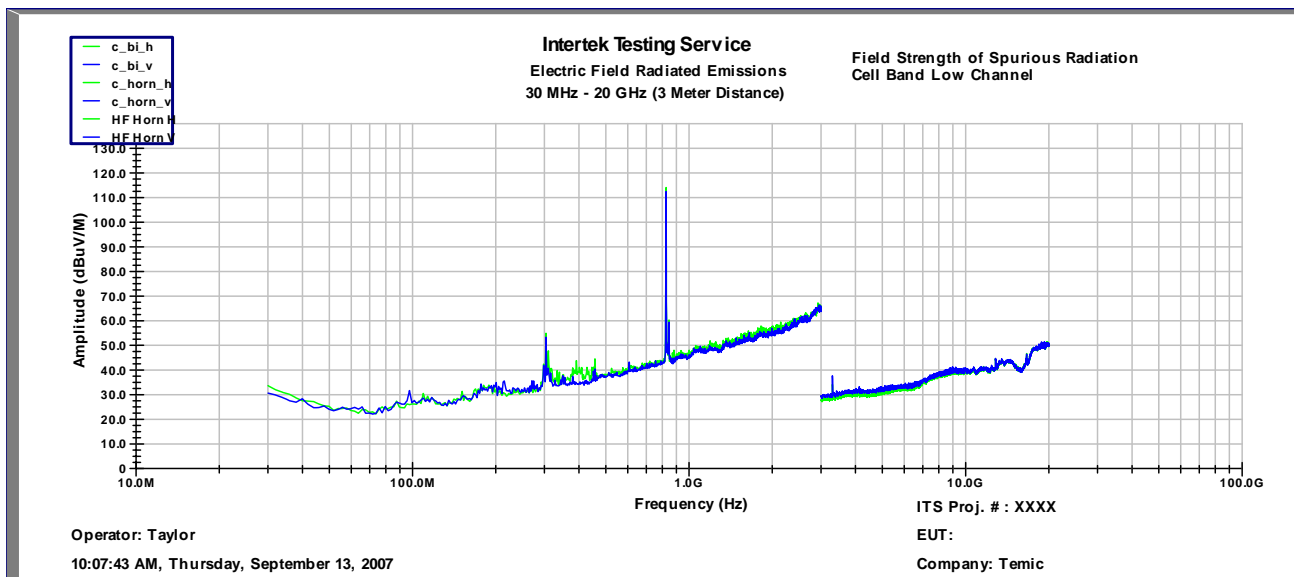

Figure 9-5: Field Strength of Spurious Radiation (30 MHz – 20 GHz), CDMA Cell Channel 384

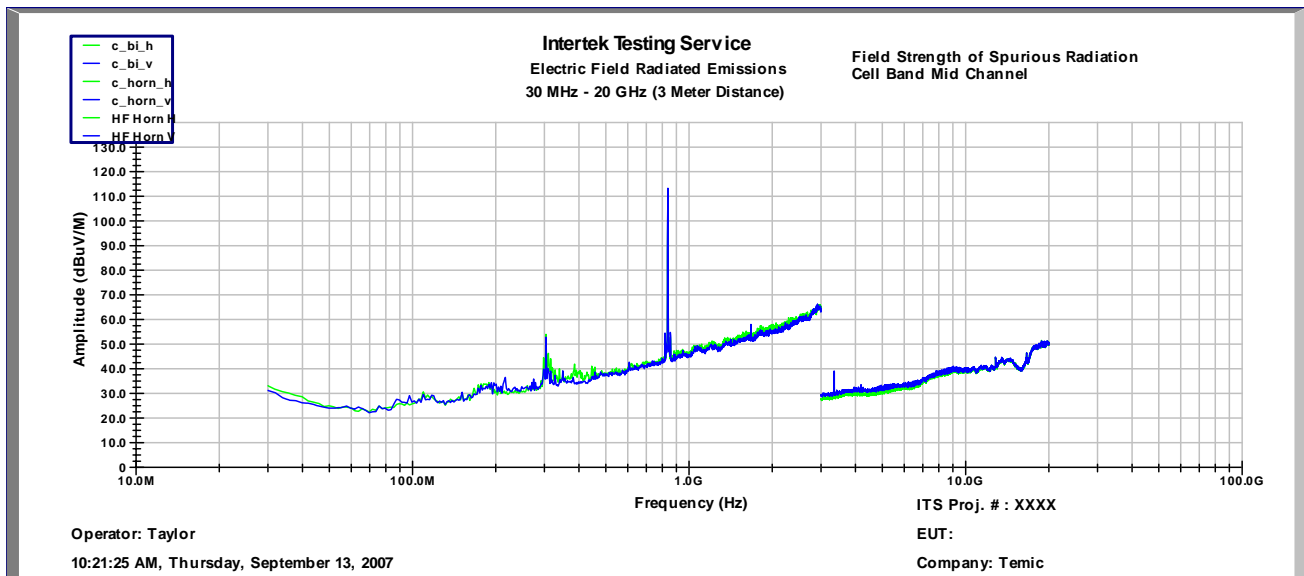

Figure 9-6: Field Strength of Spurious Radiation (30 MHz – 20 GHz), CDMA Cell Channel 777

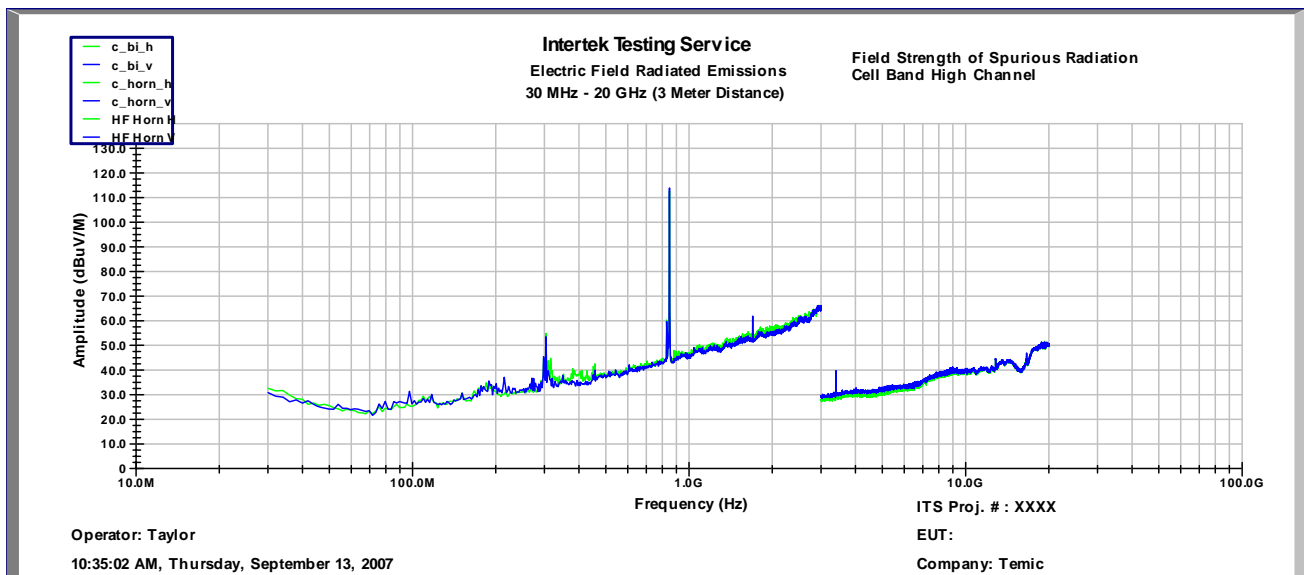

Figure 9-7: Field Strength of Spurious Radiation (30 MHz – 20 GHz), CDMA PCS Channel 25

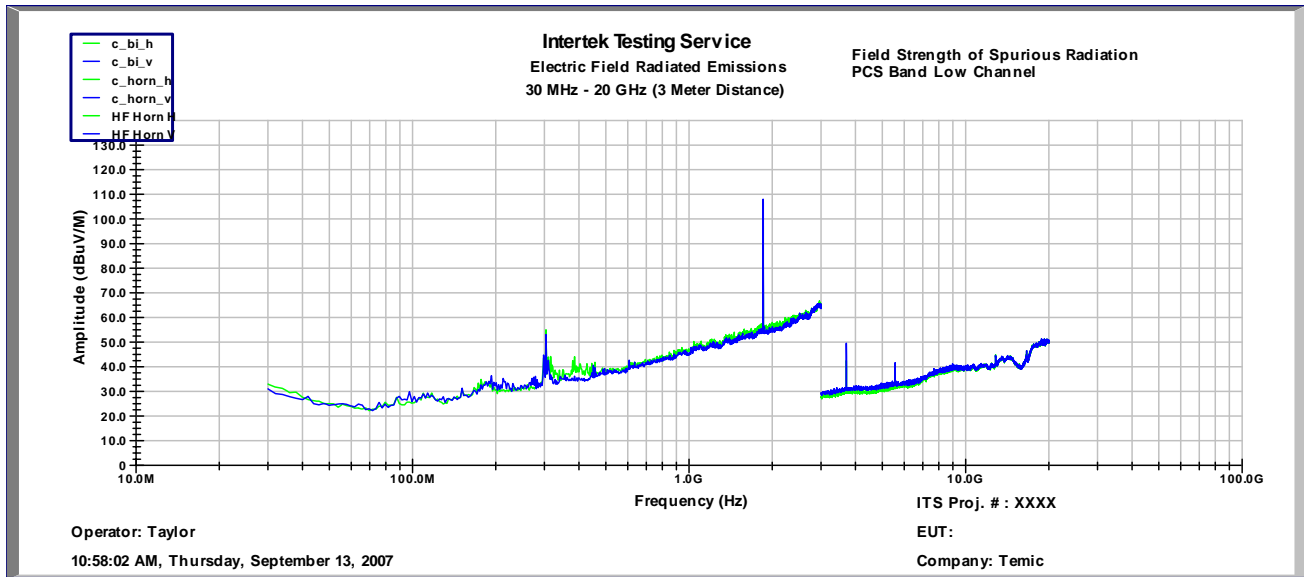

Figure 9-8: Field Strength of Spurious Radiation (30 MHz – 20 GHz), CDMA PCS Channel 600

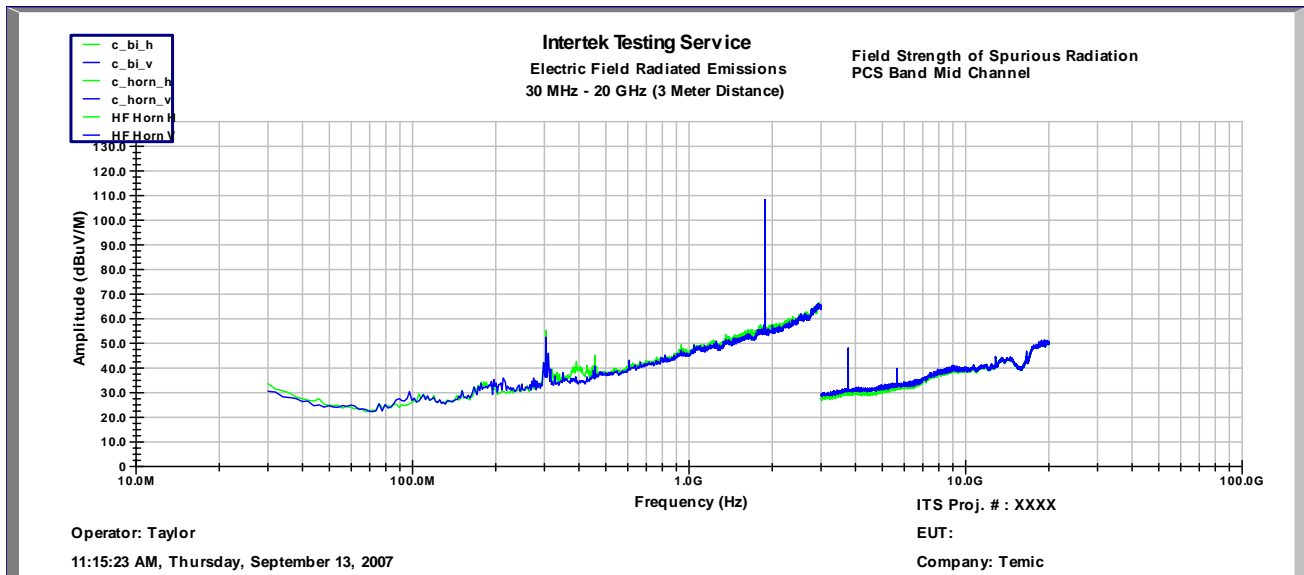
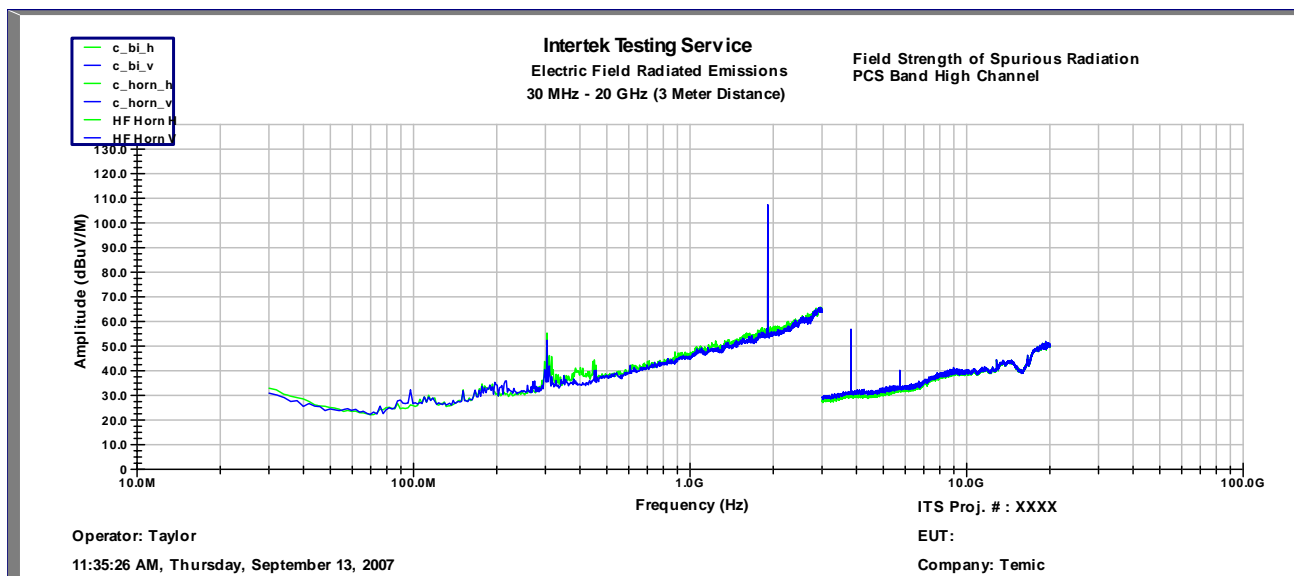

Figure 9-9: Field Strength of Spurious Radiation (30 MHz – 20 GHz), CDMA PCS Channel 1175



**10 MODULATION LIMITING, TX AUDIO FREQUENCY RESPONSE, SIDEBAND POWER ATTENUATION**

FCC §2.1047

RSS-129 (6.1), RSS-129 (6.2), RSS-129 (6.3)

**10.1 Test Procedure**Modulation Deviation Limiting:

The device under test was connected to a base station simulator and placed into a call. The audio path was setup using test commands provided by the customer. The output of the transmitter was connected to a modulation analyzer set to measure the peak deviation of the carrier frequency. A function generator was connected to the microphone input of the device under test. The audio input frequency was set to 1kHz and the level was adjusted to obtain a peak deviation of  $\pm 8$ kHz. This level was increased by 20dB in one step and the input frequency was adjusted between 300Hz and 3kHz. A plot of peak deviation versus frequency was constructed.

The device was setup as described above. A function generator was used to provide variable amplitude input at 300Hz, 1kHz, and 3kHz. The input was adjusted from 1mV to 10V at each of the three discrete frequencies while recording the peak deviation of the carrier at each step. A family of curves was constructed to show modulation limiting of the device.

Transmitter Audio Frequency Response:

The frequency response of the audio modulating circuit over the frequency range of 100Hz – 5kHz was measured. The device was setup as described above. The audio signal input was adjusted to obtain 50% modulation at 1kHz and this point was taken to be the 0dB reference point. With the input level held constant, the frequency was varied over the range of 100Hz – 5kHz and the peak deviation was measured. The deviation response was calculated as  $20 \cdot \log(\text{measured deviation}/\text{reference deviation})$ . The transmitter audio frequency response referenced to 1kHz was plotted.

Sideband Power Attenuation Limits:

The device was setup as described above. A measurement was performed with the carrier unmodulated. The peak level of the unmodulated carrier is used as the reference level. For voice, the carrier was modulated with a 2.5kHz sine wave 13.5dB greater than that required to produce  $\pm 8$ kHz deviation at 1kHz. For voice and SAT, the carrier was modulated with a 2.5kHz sine wave 13.5dB greater than that required to produce  $\pm 8$ kHz deviation at 1kHz and a 6kHz SAT with  $\pm 2$ kHz deviation. For SAT and Signaling Tone, carrier was modulated with a 10kHz ST with  $\pm 8$ kHz peak deviation and a 6kHz SAT with  $\pm 2$ kHz deviation. For wideband data, the carrier was modulated with a quasi-random 10kbps data pattern with  $\pm 8$ kHz peak deviation.

**10.2 Test Results**

The G80050AUAL was compliant with requirements of FCC §2.1047, RSS-129 (6.1), RSS-129 (6.2), and RSS-129 (6.3). The modulation was limited to less than  $\pm 12$ kHz peak deviation. The sideband power was attenuated below the limits of RSS-129 (6.3).

Figure 10-1: Modulation Limiting – Deviation vs. Frequency

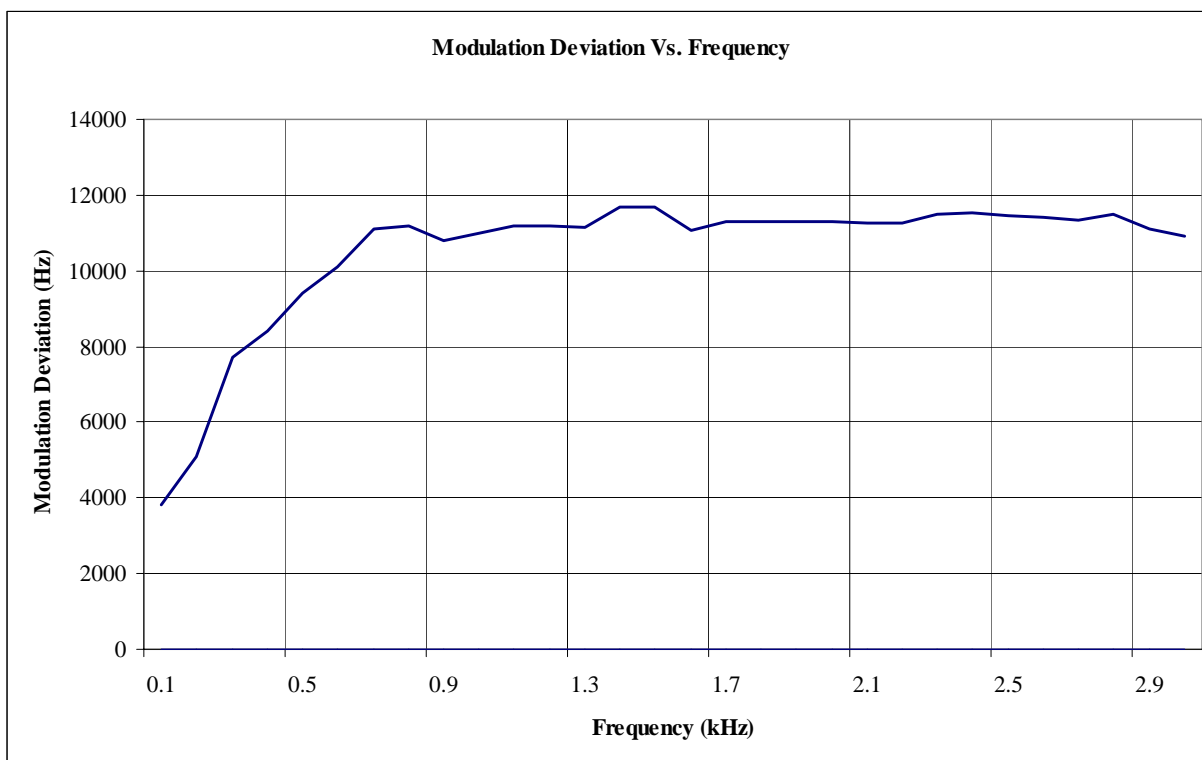



Figure 10-2: Modulation Limiting – Deviation vs. Input Voltage

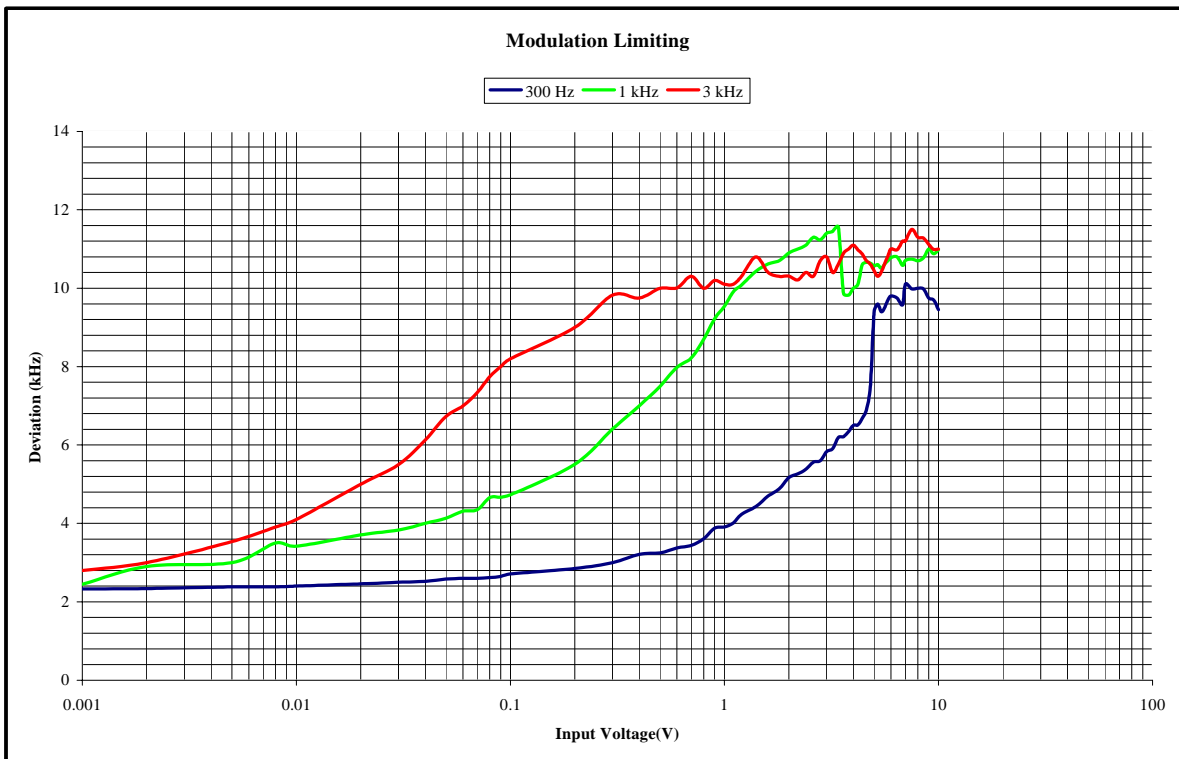

Figure 10-3: Transmitter Audio Frequency Response

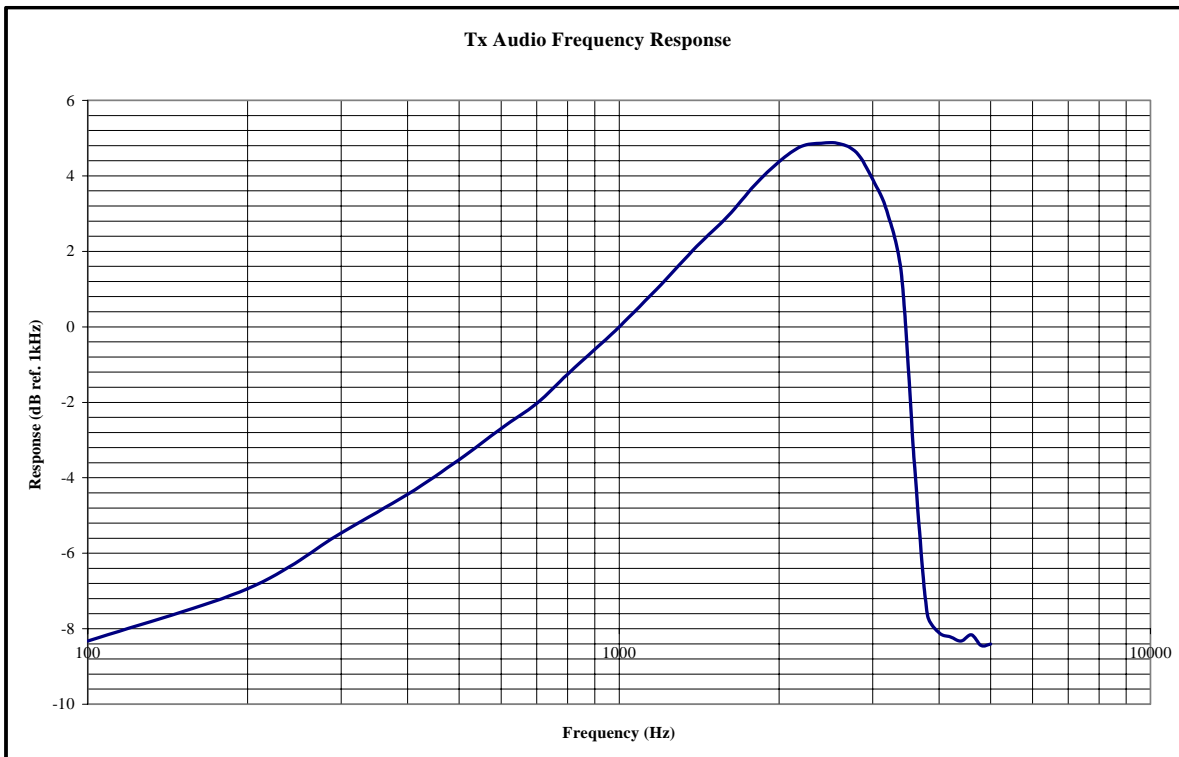
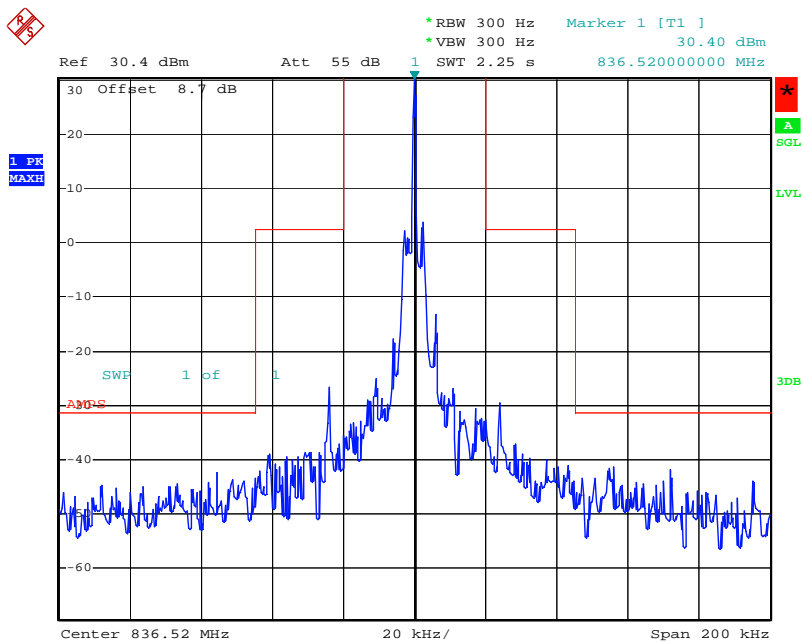
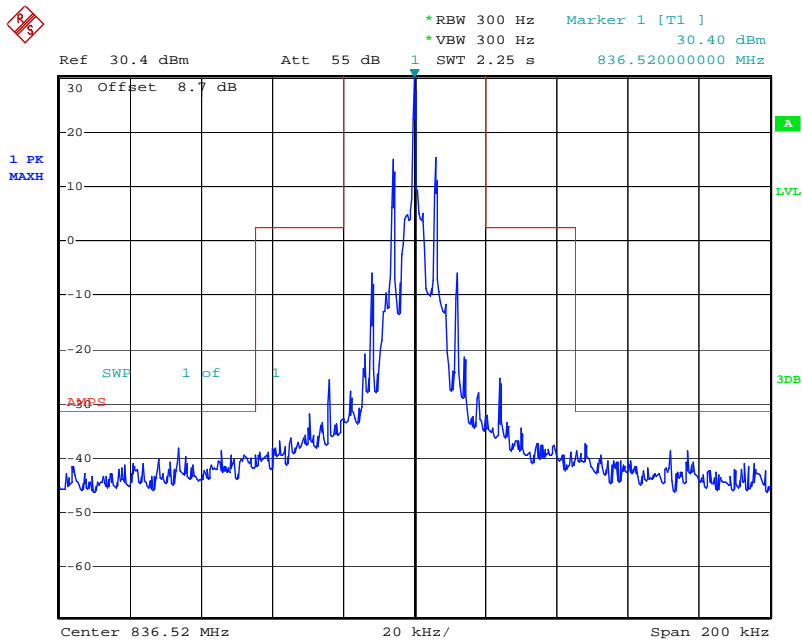

Figure 10-4: Sideband Power Attenuation – Unmodulated



Date: 16.SEP.2007 13:31:49

Figure 10-5: Sideband Power Attenuation – SAT



Date: 16.SEP.2007 13:39:10

Figure 10-6: Sideband Power Attenuation – SAT & ST

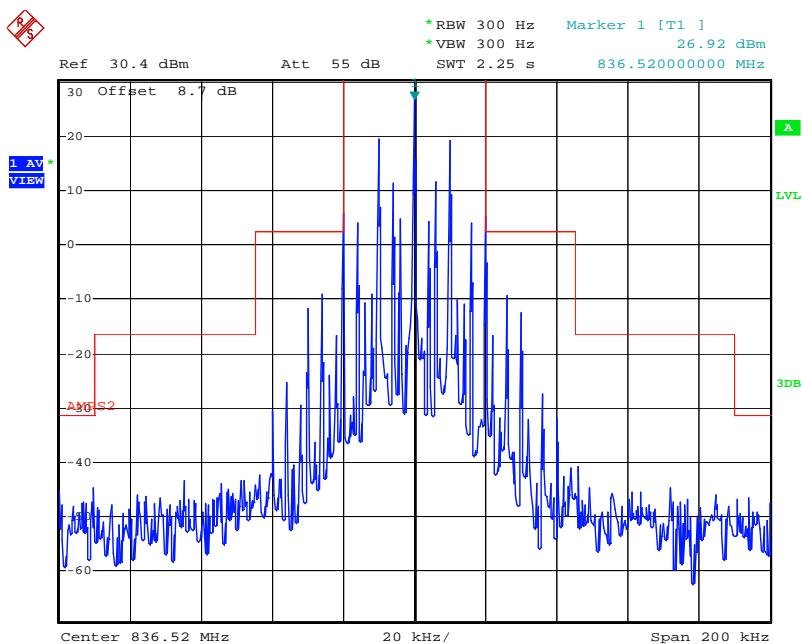

Date: 16.SEP.2007 14:01:04

Figure 10-7: Sideband Power Attenuation – Voice & SAT

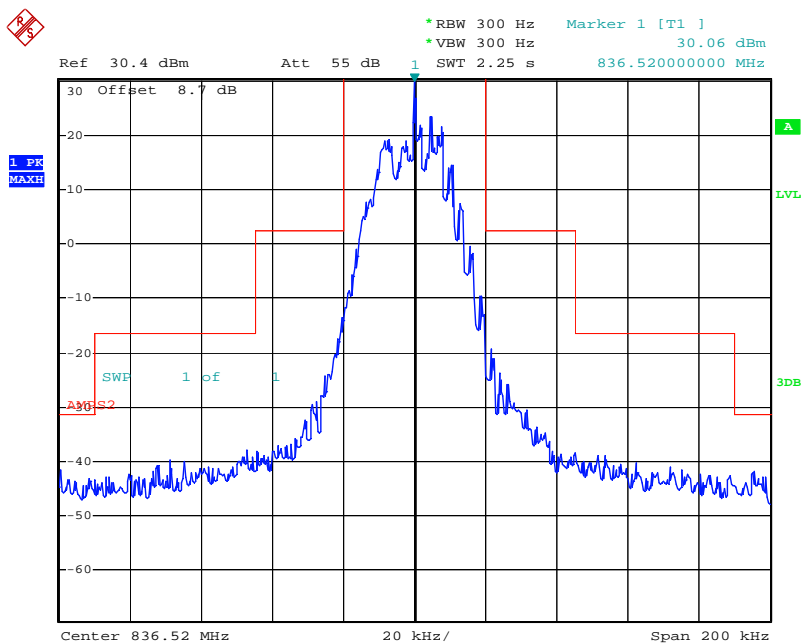

Date: 16.SEP.2007 13:48:46

Figure 10-8: Sideband Power Attenuation – Wideband Data

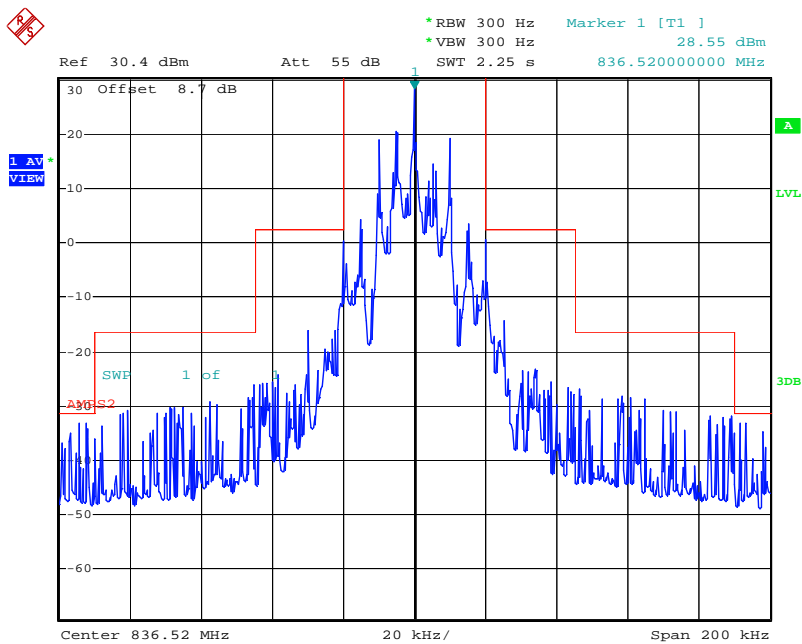

Date: 16.SEP.2007 13:58:06

**11 RECEIVER SPURIOUS EMISSIONS**

FCC §15.109

ICES-003, RSS-129 §10, RSS-133 §9

**11.1 Test Limits**

Table 11-1 Radiated Emission Limit for FCC §15.109

Radiated Emission Limits at 3 meters	
Frequency (MHz)	Quasi-Peak limits, dB (µV/m)
30 to 88	40.0
88 to 216	43.5
216 to 960	46.0
960 and up	54.0

**11.2 Test Procedure**

Measurements are made over the frequency range of 30 MHz to five times the highest frequency operating within the device. The measuring receiver meets the requirements of Section One of CISPR 16 and the measuring antenna correlates to a balanced dipole. From 30 to 1000 MHz, a quasi-peak detector was used for measurement. Above 1000 MHz, average measurements were performed.

Measurements of the radiated field are made with the antenna located at a distance of 3 meters from the EUT. If the field-strength measurements at 3m cannot be made because of high ambient noise level or for other reasons, measurements may be made at a closer distance, for example 1m. An inverse proportionality factor of 20 dB per decade should be used to normalize the measured data to the specified distance for determining compliance.

The antenna is adjusted between 1m and 4m in height above the ground plane for maximum meter reading at each test frequency.

The antenna-to-EUT azimuth is varied during the measurement to find the maximum field-strength readings.

The antenna-to-EUT polarization (horizontal and vertical) is varied during the measurements to find the maximum field-strength readings.

The EUT, where intended for tabletop use, is placed on a table whose top is 0.8m above the ground plane. The table is constructed of non-conductive materials. Its dimensions are 1m by 1.5m, but may be extended for larger EUT.

Equipment setup for radiated disturbance tests followed the guidelines of ANSI C63.4.

### 11.3 Test Results

The G80050AUAL is **compliant** with the radiated disturbance requirements of FCC §15.109 for a class B device. The maximized emissions data can be found in Figure 11-2.

Figure 11-1 FCC §15.109 Receiver Spurious Emissions Graphical Data

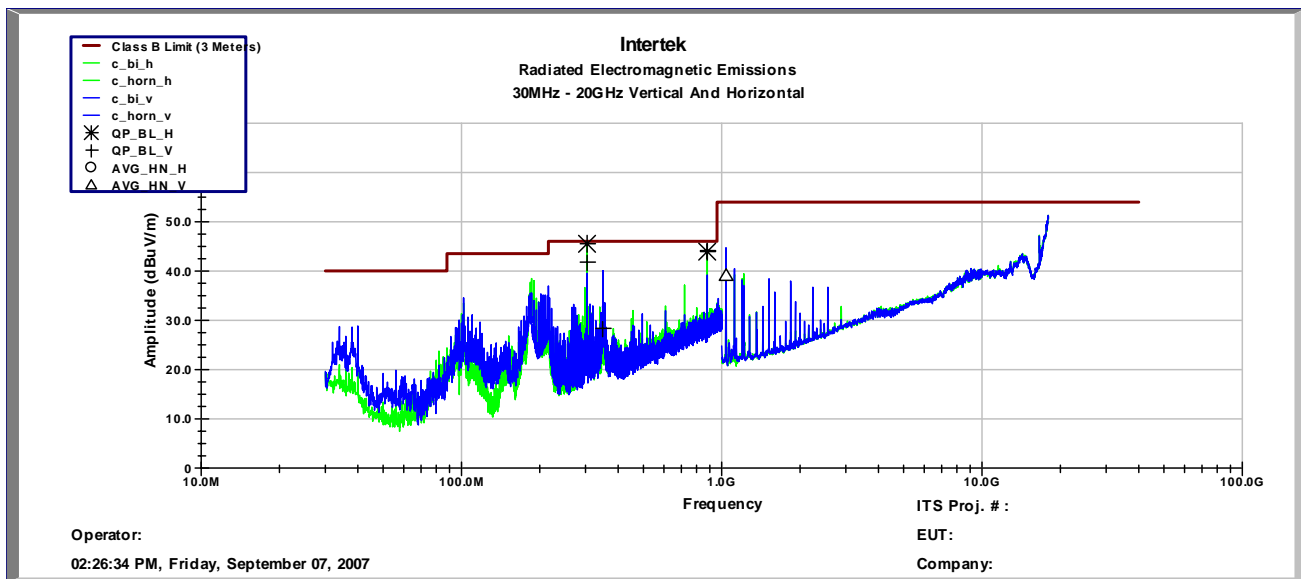

Figure 11-2 FCC §15.109 Maximized Radiated Emissions

Frequency (MHz)	Polarity (H/V)	Reading (dBuV)	Cab. (dB)	Ant. (dB)	Corr. Reading. (dBuV/m)	Limit (dBuV/m)	Delta (dB)	Detector	Results
304.0 MHz	H	28.69	2.41	14.42	45.52	46.02	-0.5	QP	<b>Compliant</b>
880.06 MHz	V	18.07	4.27	21.8	44.14	46.02	-1.88	QP	<b>Compliant</b>
880.07 MHz	H	16.95	4.27	22.7	43.92	46.02	-2.1	QP	<b>Compliant</b>
304.0 MHz	V	25.51	2.41	13.88	41.8	46.02	-4.22	QP	<b>Compliant</b>
186 MHz	H	26.04	1.8	10.6	38.44	43.52	-5.08	PK	<b>Compliant</b>
349.0 MHz	V	10.48	2.6	15.26	28.34	46.02	-17.68	QP	<b>Compliant</b>

**12 FREQUENCY STABILITY VS TEMPERATURE**

FCC §2.1055, FCC §22.355, FCC §24.235

RSS-133 §7

Frequency tolerance: 2.5ppm

**12.1 Test Procedure**

The equipment under test was connected to an external DC power supply and the RF output was connected to a CMU-200 Base Station Simulator. The Base Station Simulator was set to force the EUT to its maximum power setting. The EUT was placed inside the temperature chamber. The DC leads and RF output cable exited the chamber through an opening made for that purpose. After the temperature stabilized for approximately 30 minutes, the frequency error was read from the base station simulator.

**12.2 Test Results**

The G80050AUAL met the frequency stability requirements of FCC §2.1055, FCC §22.355 and FCC §24.235. The test results are located in Table 12-1.

Table 12-1: Frequency Error (ppm) vs. Temperature

Temp	CDMA Cell Band			CDMA PCS Band			AMPS		
	Channel 1013	Channel 384	Channel 777	Channel 25	Channel 600	Channel 1175	Channel 991	Channel 384	Channel 799
-30	0.0158	0.0203	0.0153	0.0194	0.0197	0.0168	0.0667	0.0657	0.0648
-20	0.0230	0.0155	0.0200	0.0124	0.0176	0.0162	0.0655	0.0646	0.0648
-10	0.0170	0.0143	0.0165	0.0189	0.0144	0.0141	0.0667	0.0646	0.0660
0	0.0170	0.0335	0.0271	0.0184	0.0197	0.0162	0.0667	0.0669	0.0636
10	0.0158	0.0131	0.0153	0.0130	0.0149	0.0168	0.0667	0.0657	0.0636
20	0.0121	0.0131	0.0177	0.0151	0.0154	0.0157	0.0667	0.0657	0.0636
30	0.0133	0.0155	0.0365	0.0146	0.0149	0.0168	0.0655	0.0657	0.0648
40	0.0170	0.0191	0.0177	0.0135	0.0138	0.0189	0.0655	0.0657	0.0648
50	0.0121	0.0143	0.0130	0.0162	0.0133	0.0141	0.0655	0.0646	0.0636
60	0.0170	0.0179	0.0165	0.0173	0.0207	0.0131	0.0667	0.0646	0.0648

**13 FREQUENCY STABILITY VS VOLTAGE**

FCC §2.1055, FCC §22.355

Frequency tolerance: 2.5ppm

**13.1 Test Procedure**

An external DC power supply was connected to the battery terminals of the equipment under test. The Base Station Simulator was set to force the EUT to its maximum power setting. The voltage was set to 115% of the nominal value and was then decreased to 85% of the nominal value. The output frequency error was recorded for each battery voltage.

**13.2 Test Results**

The G80050AUAL met the frequency stability requirements of FCC §2.1055 and FCC §22.355. The test results are located in Table 13-1.

Table 13-1: Frequency Error (ppm) vs. Input Voltage

Battery Voltage	CDMA Cell Band			CDMA PCS Band			AMPS		
	Channel 1013	Channel 384	Channel 777	Channel 25	Channel 600	Channel 1175	Channel 991	Channel 384	Channel 799
9VDC	0.0158	0.0143	0.0153	0.0130	0.0319	0.0136	0.0667	0.0646	0.0636
16VDC	0.0158	0.0143	0.0177	0.0167	0.0170	0.0141	0.0680	0.0646	0.0648